



EUROPEAN
TELECOMMUNICATION
STANDARD

ETS 300 160

January 1997

Second Edition

Source: ETSI TC-SES

Reference: RE/SES-00010

ICS: 33.020

Key words: Satellite, earth station, VSAT, control, NCF

**Satellite Earth Stations and Systems (SES);
Control and monitoring functions at a
Very Small Aperture Terminal (VSAT)**

ETSI

European Telecommunications Standards Institute

ETSI Secretariat

Postal address: F-06921 Sophia Antipolis CEDEX - FRANCE

Office address: 650 Route des Lucioles - Sophia Antipolis - Valbonne - FRANCE

X.400: c=fr, a=atlas, p=etsi, s=secretariat - **Internet:** secretariat@etsi.fr

Tel.: +33 4 92 94 42 00 - Fax: +33 4 93 65 47 16

Copyright Notification: No part may be reproduced except as authorized by written permission. The copyright and the foregoing restriction extend to reproduction in all media.

© European Telecommunications Standards Institute 1997. All rights reserved.

Contents

Foreword	5
1 Scope	7
2 Normative references	7
3 Definitions	7
4 Abbreviations	8
5 Test report	8
6 Specifications	8
6.1 General	8
6.2 Specification of states	10
6.3 Control Channel(s) (CC)	11
6.4 Self monitoring functions	12
6.4.1 Processor monitoring	12
6.4.2 Transmit subsystem monitoring	13
6.4.3 VSAT transmission validation	13
6.4.3.1 VSAT transmission validation by the CCMF	13
6.4.3.2 VSAT transmission validation by receiving station(s)	13
6.4.3.3 Transmission validation for VSATs using external CC(s)	14
6.5 Central control functions	14
6.5.1 Disable message	14
6.5.2 Enable message	15
6.6 Power-on/reset	15
History	16

Blank page

Foreword

This second edition European Telecommunication Standard (ETS) has been produced by the Satellite Earth Stations and Systems (SES) Technical Committee of the European Telecommunications Standards Institute (ETSI).

Every ETS approved by ETSI is a voluntary standard. This ETS may contain text concerning type approval of the equipment to which it relates. This text should be considered as guidance only and does not make this ETS mandatory.

Transposition dates	
Date of adoption	20 December 1996
Date of latest announcement of this ETS (doa):	30 April 1997
Date of latest publication of new National Standard or endorsement of this ETS (dop/e):	31 October 1997
Date of withdrawal of any conflicting National Standard (dow):	31 October 1997

Blank page

1 Scope

This second edition European Telecommunication Standard (ETS) is applicable to two-way (transmit and receive) as well as transmit-only Very Small Aperture Terminal (VSAT) satellite earth stations operating in the framework of a satellite network for digital communication purposes as defined in ETS 300 159 [1] and ETS 300 332 [3]. In these networks there is a set of control and monitoring functions at each VSAT and a separate set of Centralized Control and Monitoring Functions (CCMF). The control and monitoring functions are designed to limit interferences to users of the frequency spectrum due to a fault condition at the VSAT. This ETS is applicable to VSATs operating in any network configuration including star, mesh and point-to-point connections.

This ETS specifies the control and monitoring functions of a VSAT. ETS 300 161 [2] specifies the CCMF.

The VSATs which are the subject of this ETS, are designed for unattended operation and with transmission capability limited to baseband digital signals. Transmission and reception at a VSAT relate to transmission and reception over the satellite.

CCMF constitute a set of functional entities that, at system level, monitor and control the correct operation of all VSATs in a network.

This ETS does not include any specification or information about the installation of the VSAT.

2 Normative references

This ETS incorporates by dated or undated references, provisions from other publications. These normative references are cited at the appropriate places in the text and the publications are listed hereafter. For dated references, subsequent amendments to, or revisions of any of these publications apply to this ETS only when incorporated in it by amendment or revision. For undated references the latest edition of the publication referred to applies.

- [1] ETS 300 159: "Satellite Earth Stations and Systems (SES); Transmit/receive Very Small Aperture Terminals (VSATs) used for data communications operating in the Fixed Satellite Service (FSS) 11/12/14 GHz frequency bands".
- [2] ETS 300 161: "Satellite Earth Stations and Systems (SES); Centralized control and monitoring functions for VSAT networks".
- [3] ETS 300 332: "Satellite Earth Stations and Systems (SES); Transmit/receive Very Small Aperture Terminals (VSATs) used for data communications operating in the Fixed Satellite Service (FSS) 6 GHz and 4 GHz frequency bands".

3 Definitions

For the purpose of this ETS, the following definitions apply:

Control Channel(s): A channel or channels by which VSATs receive control information from the CCMF.

Response Channel(s): A channel or channels by which VSATs transmit monitoring information to the CCMF.

network: In this ETS a network is any network configuration including star, mesh and point-to-point configurations.

internal control channel: A control channel which is carried by the VSAT network via the same satellite as used for transmission of user data and within the internal protocol structure of the VSAT system.

external control channel: A control channel which is either (i) carried by the VSAT network via the same or another satellite, but not within the internal protocol structure of the VSAT system, or (ii) carried by the PSTN or some other means.

internal response channel: A response channel which is carried by the VSAT network via the same satellite as used for transmission of user data and within the internal protocol structure of the VSAT system.

external response channel: A response channel which is either (i) carried by the VSAT network via the same or another satellite, but not within the internal protocol structure of the VSAT system, or (ii) carried by the PSTN or some other means.

4 Abbreviations

For the purpose of this ETS, the following abbreviations apply:

CC	Control Channel
CCD	Central Control Disable
CCE	Central Control Enable
CCMF	Centralized Control and Monitoring Functions
CV	Control Variable
EIRP	Equivalent Isotropically Radiated Power
PSTN	Public Switched Telephone Network
RC	Response Channel
RE	Reset Event
SMF	Status Monitoring Fail event
SMP	Status Monitoring Pass event
SMV	Self Monitoring Variable
VSAT	Very Small Aperture Terminal

5 Test report

The test report shall contain:

- the type of control channel(s) (CC);
- the characteristics of the external CCs including protocols;
- the test results.

6 Specifications

6.1 General

This ETS specifies a minimum set of control and monitoring functions that shall be implemented in VSATs in order to minimize the probability that they may originate transmissions that may interfere with other systems.

A VSAT shall implement two sets of control and monitoring functions:

- a) Monitoring functions: these functions encompass all the checks and verifications that the VSAT shall perform in order to identify any anomalous situation which may cause impairments to other systems.

The overall result of these checks and verifications are contained in a functional variable named Self Monitoring Variable (SMV). The states of this variable are "Pass" and "Fail".

The state of the SMV may change as a result of events. These are:

- Status Monitoring Pass event (SMP);
- Status Monitoring Fail event (SMF).

The circumstances under which these events may take place are specified in subclause 6.4 of this ETS.

- b) Control functions: these functions are associated with the ability of the CCMF to inhibit and to permit transmissions from an individual VSAT as specified in ETS 300 161 [2].

These functions are reflected in the state of a functional variable, resident at each VSAT, named Control Variable. The states of this variable are "enable" and "disable".

The Control Variable may change as a result of events. These are:

- Central Control Disable (CCD);
- Central Control Enable (CCE).

The circumstances associated to the reception of the messages resulting in these events are specified in subclause 6.5 of this ETS.

Besides these two sets of control and monitoring functions, the VSATs shall achieve a controlled non-transmitting state following actuation of the terminal (power-on).

VSATs that allow local operator intervention may include a terminal reset function which when actuated results in a Reset Event (RE).

Subclause 6.6 specifies the functions associated with the occurrence of the "power-on" and REs.

The combination of the SMV and CV results in the definition of 4 possible states in which a VSAT may be from the control and monitoring point-of-view.

The states of the VSAT are:

- out-of-service;
- checking;
- stand-by;
- in-service.

Figure 1 shows the state transition diagram associated with these 4 states. The operational behaviour of the VSAT (with respect to control and monitoring), in each of these states, is specified in subclause 6.2.

In the "in-service" state, the SMF and CCD events may be processed as the RE, in order to set the VSAT in the "out-of-service" state.

In the "out-of-service" state the first or all CCE events may be ignored.

When the VSAT transmits several carriers having different frequencies, a VSAT state machine as described above may be associated with each carrier or each set of carriers. The events then apply to the subsystem associated with the specific carrier or the specific set of carriers, rather than the whole VSAT.

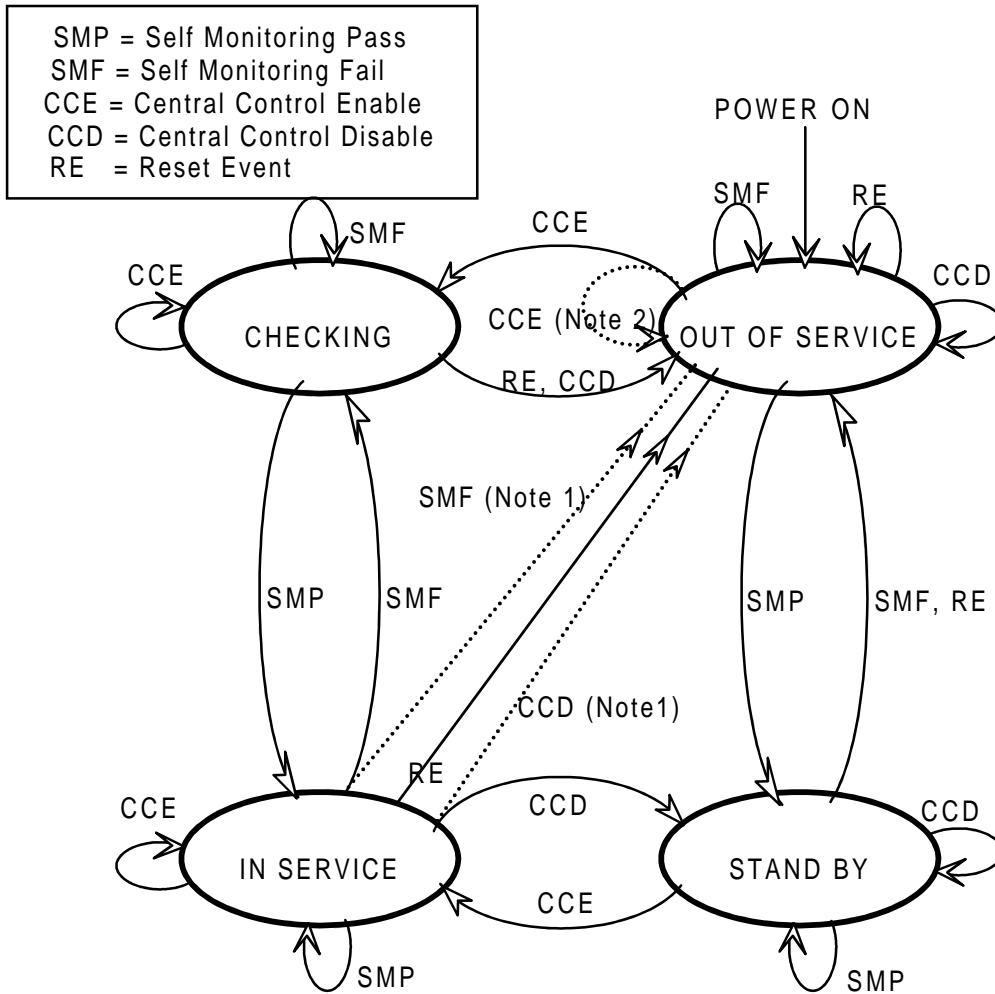

NOTE 1: In the "in-service" state, the occurrence of a SMF and/or CCD may result in a transition to the "out-of-service" state.

NOTE 2: In the "out-of-service" state, the occurrence of the first or all CCE events may be ignored.

Figure 1: State transition diagram of the control and monitoring function of a VSAT

6.2 Specification of states

The "checking" state shall apply when the SMV is "fail" and when the CV is "enable". In the "checking" state, the VSAT shall not transmit.

The "out-of-service" state shall apply when the SMV is "fail" and when the CV is "disable". In the "out-of-service" state the VSAT shall not transmit. This state shall be entered following power-on or reset.

The "stand-by" state shall apply when the SMV is "pass" and when the CV is "disable". In the "stand-by" state, the VSAT shall not transmit.

The "in-service" state applies when the SMV is "pass" and when the CV is "enable". In the "in-service" state the VSAT is allowed to transmit.

The VSAT is in the "transmission disable" state when it is not allowed to transmit by the CCMF.

When the VSAT shall not transmit or is not allowed to transmit by the CCMF, the levels of the inband and spurious radiation shall be as specified in ETS 300 159 [1], and ETS 300 332 [3] respectively, for the "transmission disable" state.

The verification shall be limited to the on-axis EIRP spectral density of the wanted signal and the spurious, within the band for the "transmission disable" state.

NOTE: It is not expected that the spurious radiation increase under fault conditions.

6.3 Control Channel(s) (CC)

Purpose:

Control Channel(s) are used to receive control information from the CCMF.

Specifications:

a) Specification 1:

The VSAT shall have at least one Control Channel (CC) with the CCMF. The CC(s) shall be either internal to the VSAT network, or external to it.

NOTE 1: The availability of the external CC(s) and the number of external CCs are not within the scope of this ETS.

NOTE 2: Some satellite operators may require that internal CC(s) are available.

b) Specification 2 for internal CC(s):

The VSAT shall monitor the operation of its CC receive subsystem, i.e. its ability to lock to the received carrier frequency, demodulate, decode and receive messages from the CCMF.

Failure of the CC receive subsystem for a period of time not exceeding 30 seconds shall result in a SMF event. The corresponding change of state shall occur no later than 33 seconds after the beginning of the failure.

c) Specification 3 for internal CC(s):

The VSAT shall hold, in non-volatile memory, two unique identification codes:

- the identification code of the control channel or channels which it is authorized to receive; and
- the identification code of the VSAT when the CC is received by more than one VSAT.

Failure to receive and validate an authorized control identification code for a period of time not exceeding 60 seconds shall result in a SMF event. The corresponding change of state shall occur no later than 63 seconds after the beginning of the failure.

The VSAT shall be capable of receiving, via any authorized control channel, messages addressed to the VSAT containing CCD and CCE.

d) Specification 4 for external CC(s):

The VSAT shall be able either to be permanently connected to the CCMF or to be connected to the CCMF on demand, in order to receive messages from the CCMF containing CCD and CCE.

Verification:

a) Verification of specification 1:

Compliance shall be verified by documentary evidence and demonstration.

The type of CC (internal or external) shall be recorded in the test report.

The characteristics of the external CC interface of the VSAT, including protocols, shall be declared and recorded in the test report.

b) Verification of specification 2:

Compliance shall be verified by documentary evidence and demonstration. The demonstration shall show that all transmissions are suppressed not later than 33 seconds following a CC receive subsystem fault.

c) Verification of specification 3:

The method of setting and storing the control channel(s) and the VSAT identification codes shall be verified by documentary evidence.

The VSAT shall suppress its transmissions not later than 63 seconds following the interruption of the reception of all the authorized control channel(s).

d) Verification of specification 4:

Compliance shall be verified by documentary evidence and demonstration. Each mode of connection (permanent or on demand) shall be recorded in the test report.

6.4 Self monitoring functions

In order to ensure that all the subsystems of the VSAT are operating correctly during transmission, the following self monitoring functions shall be implemented in the VSAT:

- processor monitoring;
- transmit subsystem monitoring;
- VSAT transmission validation.

The successful verification of all conditions shall result in a SMP event.

The failure of any of the conditions shall result in a SMF event.

The monitoring functions shall be performed in all states of the VSAT.

6.4.1 Processor monitoring

Purpose:

To ensure that the VSAT can suppress transmissions in the event of a processor failure.

Specification:

A VSAT shall incorporate a processor monitoring function for each of its processors involved in the manipulation of traffic and in the control and monitoring functions.

The processor monitoring function shall verify the correct operation of the processor hardware and software.

The detection by the processor monitoring function of a processor fault for a period of time not exceeding 30 seconds shall result in an SMF event. The corresponding change of state shall occur no later than 33 seconds after the fault occurrence.

Verification:

Compliance shall be verified by documentary evidence and demonstration.

The demonstration shall show that all transmissions are suppressed within 33 seconds following a controllable processor induced fault (e.g. processor reset applied; processor board disconnected). The manufacturer shall provide the explanation of how to induce the appropriate fault(s).

6.4.2 Transmit subsystem monitoring

Purpose:

To ensure that the VSAT can suppress the transmissions in the event of a transmit subsystem error.

Specification:

A VSAT shall monitor the operation of its transmit frequency generation subsystem.

Failure of the transmit frequency generation subsystem for a period of time not exceeding 5 seconds shall result in a SMF event. The corresponding change of state shall occur no later than 8 seconds after the beginning of the failure.

Verification:

Compliance shall be verified by documentary evidence.

6.4.3 VSAT transmission validation

For a VSAT using internal CC(s) two alternative methods exist to confirm that the VSAT transmissions are being correctly received. These are:

- transmission validation by the CCMF in accordance with subclause 6.4.3.1;
- transmission validation by receiving station(s) in accordance with subclause 6.4.3.2.

For those VSATs using internal CC(s) at least one of these methods shall be implemented.

For a VSAT using external CC(s) the specification in subclause 6.4.3.3 applies.

6.4.3.1 VSAT transmission validation by the CCMF

Purpose:

To verify the ability of a transmitting VSAT to send status messages on request received from the CCMF in order to have its correct operation validated.

Specification:

When the VSAT is in the "in-service" state, and when it receives a "poll-for-status message" from the CCMF via a CC, the VSAT shall transmit a "status message". The status message may be transmitted by the VSAT periodically thereafter without further stimuli from the CCMF.

The "status message" shall be transmitted via an internal RC. The "status message" is used by the CCMF to verify the correct transmission of the VSAT.

Verification:

Compliance by documentary evidence and demonstration.

6.4.3.2 VSAT transmission validation by receiving station(s)

Purpose:

To ensure that the VSAT transmits correctly, by informing the VSAT that its transmissions are being correctly received at receiving station(s).

For every 10 minutes during which the VSAT transmits at least once, the VSAT should receive at least one "transmission validation message" indicating that its transmissions are being received at the receiving station(s).

Specification:

If no "transmission validation message" has been received by the VSAT for more than 10 minutes after any transmission, it shall result in a SMF event and the corresponding change of state shall occur no later than 11 minutes from the last "transmission validation message".

Verification:

Compliance by documentary evidence and demonstration.

6.4.3.3 Transmission validation for VSATs using external CC(s)

Purpose:

To ensure that the transmitting VSAT remains controllable and transmits correctly, by requesting the VSAT to send to the CCMF one or multiple status messages.

Specification:

When the VSAT is in the "in-service" state, and when it receives a "poll-for-status message" via the CC(s) the VSAT shall respond with a "status message".

The "status message" shall be either:

- transmitted via an external RC and shall contain the values of the assigned EIRP and carrier frequencies of the VSAT; or
- transmitted via an internal RC. In that case, the "status message" is used by the CCMF to verify the correct transmission of the VSAT.

Verification:

Compliance by documentary evidence and demonstration.

6.5 Central control functions

This subclause specifies the conditions the VSAT shall satisfy to consider that it is authorized to transmit.

6.5.1 Disable message

Purpose:

To verify the ability of a transmitting VSAT to suppress all its transmissions when it receives a CCD message from the CCMF.

Specification:

Reception of a CCD message from the CCMF shall result in a CCD event and the corresponding change of state shall occur within 3 seconds of that event.

Verification:

Compliance shall be determined by documentary evidence and demonstration.

It shall be demonstrated that a transmitting VSAT suppresses all transmissions when receiving a CCD message on a control channel.

6.5.2 Enable message

Purpose:

To verify the ability of a VSAT to transmit when it has received a CCE message from the CCMF.

Specification:

Reception of CCE message from the CCMF shall result in a CCE event.

Verification:

Compliance shall be determined by documentary evidence and demonstration.

It shall be demonstrated that a previously disabled VSAT shall begin transmission upon the reception of a CCE message when the VSAT has data to transmit.

6.6 Power-on/reset

Purpose:

To demonstrate that the VSAT achieves a controlled non-transmitting state following the powering-on of the unit, or the occurrence of a reset made by a local operator when this function is implemented.

Specification:

Following "power-on" the VSAT shall enter the "out-of-service" state.

Following the application of a reset to the VSAT, a RE shall be considered to have taken place, causing the unit to enter the "out-of-service" state within 3 seconds.

NOTE: To leave the "out-of-service" state or the "stand-by" state, the VSAT needs to receive a CCE message from the CCMF. This CCE message could be either:

- requested by the VSAT via an external CC not carried by the same VSAT network; or
- sent by the CCMF regularly via an internal CC; or
- via an external CC within the same VSAT network.

The manner of reception of this CCE remains a design matter.

History

Document history			
November 1992	First Edition		
February 1996	Public Enquiry	PE 102:	1996-02-19 to 1996-06-14
October 1996	Vote	V 113:	1996-10-21 to 1996-12-13
January 1997	Second Edition		