



EUROPEAN
TELECOMMUNICATION
STANDARD

ETS 300 135

June 1991

Source: ETSI TC-RES

Reference:

ICS: 33.060.20

Key words: radio, citizens' band

**Radio Equipment and Systems;
Angle-modulated Citizens' Band radio equipment
(CEPT PR 27 Radio Equipment)
Technical characteristics and methods of measurement**

ETSI

European Telecommunications Standards Institute

ETSI Secretariat

Postal address: F-06921 Sophia Antipolis CEDEX - FRANCE

Office address: 650 Route des Lucioles - Sophia Antipolis - Valbonne - FRANCE

X.400: c=fr, a=atlas, p=etsi, s=secretariat - **Internet:** secretariat@etsi.fr

Tel.: +33 92 94 42 00 - Fax: +33 93 65 47 16

Copyright Notification: No part may be reproduced except as authorized by written permission. The copyright and the foregoing restriction extend to reproduction in all media.

© European Telecommunications Standards Institute 1991. All rights reserved.

Contents

Foreword	7
Introduction	7
1 Scope	9
2 Normative references	9
3 Definition, abbreviations and symbols	9
3.1 Definitions	9
3.2 Abbreviations	10
3.3 Symbols	10
4 General	10
4.1 Presentation of equipment for testing purposes	10
4.2 Mechanical and electrical design	10
4.2.1 General	10
4.2.2 Controls	11
4.2.3 Marking	11
4.3 Interpretation of the measurement results	11
5 Technical characteristics	11
5.1 Common characteristics	11
5.1.1 Frequency band	11
5.1.2 Carrier frequencies and channel numbers	12
5.1.3 Channel separation	12
5.1.4 Multi-channel equipment	13
5.1.5 Type of modulation	13
5.1.6 Push-to-talk (ptt) and voice activated switch	13
5.1.7 Controls	13
5.1.8 Combination with other equipment	13
5.2 Transmitter parameter limits	13
5.2.1 Frequency error	13
5.2.2 Power	13
5.2.3 Frequency deviation	13
5.2.4 Unwanted amplitude modulation	14
5.2.5 Adjacent channel power	14
5.2.6 Spurious emissions of the transmitter	14
5.2.7 Transient frequency behaviour of the transmitter	15
5.2.8 Synthesisers and Phase Locked Loop (PLL) systems	15
5.3 Receiver parameter limits	16
5.3.1 Maximum usable sensitivity	16
5.3.2 Adjacent channel selectivity	16
5.3.3 Intermodulation response rejection	16
5.3.4 Spurious radiations	16
6 Test conditions, power sources and ambient temperatures	17
6.1 Normal and extreme test conditions	17
6.2 Test power source	17
6.3 Normal test conditions	17
6.3.1 Normal temperature and humidity	17
6.3.2 Normal test power source	17
6.3.2.1 Mains voltage and frequency	17
6.3.2.2 Regulated lead-acid battery power sources on vehicles	17
6.3.2.3 Other power sources	17
6.4 Extreme test conditions	18
6.4.1 Extreme temperatures	18

6.4.2	Extreme test source voltages	18
6.4.2.1	Mains voltage	18
6.4.2.2	Regulated lead-acid battery power sources on vehicles	18
6.4.2.3	Power sources using other types of battery	18
6.4.2.4	Other power sources	18
6.5	Procedure for tests at extreme temperatures	18
6.5.1	Test procedure	18
7	General conditions	19
7.1	Arrangements for test signals applied to the receiver input	19
7.2	Receiver mute or squelch facility	19
7.3	Receiver rated audio output power	19
7.4	Normal test modulation	19
7.5	Artificial antenna	19
7.6	Test fixture	19
7.7	Arrangement for test signals at the input of the transmitter	20
7.8	Test site and general arrangements for radiated measurements	20
8	Method of measurement for transmitter parameters	20
8.1	Frequency error	20
8.1.1	Definition	20
8.1.2	Method of measurement	20
8.2	Transmitter carrier power	20
8.2.1	Definition	20
8.2.2	Method of measurement (for equipment other than equipment with integral antenna only)	20
8.2.3	Method of measurement for equipment with integral antenna	20
8.3	Maximum frequency deviation	21
8.3.1	Maximum permissible frequency deviation	21
8.3.1.1	Definition	21
8.3.1.2	Method of measurement	21
8.4	Unwanted amplitude modulation	21
8.4.1	Method of measurement	21
8.5	Adjacent channel power	22
8.5.1	Definition	22
8.5.2	Method of measurement	22
8.6	Spurious emissions	22
8.6.1	Definition	22
8.6.2	Method of measuring the power level in a specified load, subclause 8.6.1 (a)	22
8.6.3	Method of measuring the effective radiated power, subclause 8.6.1 (b)	23
8.6.4	Method of measuring the effective radiated power, subclause 8.6.1 (c)	24
8.7	Transient frequency behaviour of the transmitter	24
8.7.1	Definitions	24
8.7.2	Method of measurement	24
9	Methods of measurement for receiver parameters	27
9.1	Maximum usable sensitivity	27
9.1.1	Definition	27
9.1.2	Method of measuring the SND/ND ratio	27
9.2	Adjacent channel selectivity	27
9.2.1	Definition	27
9.2.2	Method of measurement	27
9.3	Intermodulation response rejection	28
9.3.1	Definition	28
9.3.2	Method of measurement	28
9.4	Spurious radiations	28
9.4.1	Definition	28
9.4.2	Method of measuring the power level in a specified load, subclause 9.4.1 (a)	29
9.4.3	Method of measuring the effective radiated power, subclause 9.4.1 (b)	29
9.4.4	Method of measuring the effective radiated power, subclause 9.4.1 (c)	29

10	Measurement uncertainty.....	30
Annex A:	Radiated measurement.....	31
A.1	Test sites and general arrangements for measurements involving the use of radiated fields	31
A.1.1	Outdoor test site.....	31
A.1.1.2	Test site for handportable stations	31
A.1.2	Test antenna.....	32
A.1.3	Substitution antenna	32
A.1.4	Optional additional indoor site.....	32
A.2	Guidance on the use of radiation test sites	33
A.2.1	Measuring distance	33
A.2.2	Test antenna	33
A.2.3	Substitution antenna	34
A.2.4	Artificial antenna	34
A.2.5	Auxiliary cables	34
A.3	Further optional alternative indoor test site using an anechoic chamber	34
A.3.1	Example of the construction of a shielded anechoic chamber	34
A.3.2	Influence of parasitic reflections in anechoic chambers	35
A.3.3	Calibration of the shielded anechoic chamber	35
Annex B:	Specification for adjacent channel power measurement arrangements.....	37
B.1	Power measuring receiver specification.....	37
B.1.1	IF filter	37
B.1.2	Variable attenuator.....	38
B.1.3	Rms value indicator	38
B.1.4	Oscillator and amplifier	38
History.....		39

Blank page

Foreword

This European Telecommunication Standard (ETS) has been prepared by an Experts' Group of the Radio Equipment and Systems (RES) Technical Committee of the European Telecommunications Standards Institute (ETSI). The standard has undergone the formal ETSI approval process and is now adopted.

This ETS concerns only angle modulation. The existing national Citizens' Band standards or specifications which also permit the use of other forms of modulation (including amplitude and single sideband) will not be affected by the adoption of this ETS.

This standard is based upon CEPT Recommendation T/R 20-02 [1], originally prepared by the CEPT R22 Committee for use by Citizens' Band (CB) radio equipment.

Angle modulation shall be used for radio equipment covered by this standard, with an audio pre-emphasis characteristic for the transmitter, and audio de-emphasis for the receiver.

Administrative arrangements (e.g. for type approval, marking, antennas), and conditions for the use of CB angle modulated radio (CEPT PR 27) are to be found in CEPT Recommendations T/R 20-02 and T/R 20-07 [2].

Every ETS prepared by ETSI is a voluntary standard. This ETS contains text concerning type approval of the equipment to which it relates. This text should be considered only as guidance and does not make this ETS mandatory.

Introduction

This standard is intended to specify the minimum performance and the methods of measurement of Citizens' Band radio equipment (CEPT PR 27) as specified in the Scope.

Clause 5 provides the corresponding limits. These limits have been chosen to ensure an acceptable grade of service and to minimise harmful interference to other equipment and services.

This standard will also be used by European notified accredited test laboratories for the assessment of the performance of the equipment. In order to avoid any ambiguity in that assessment, this standard contains instructions for the presentation of equipment for type testing purposes (Clause 4), measurement methods (Clauses 8 and 9) and conditions (Clauses 6 and 7).

This standard was drafted on the assumption that:

- a) the type test measurements would be performed only once in one of the accredited test laboratories, and then accepted by the various authorities in order to obtain type approval;
- b) if equipment available on the market is required to be checked it shall be tested in accordance with the methods specified in this standard. This standard covers base stations, mobile stations and two categories of hand-portable stations.

Blank page

1 Scope

This standard covers the minimum characteristics considered necessary in order to make the best use of the available frequencies. It does not necessarily include all the characteristics which may be required by a user, nor does it necessarily represent the optimum performance achievable. It applies to angle modulated Citizens' Band radio equipment (CEPT PR 27) operation in the frequency band 26.960 MHz to 27.410 MHz with channel separations of 10 kHz, and intended for analogue speech.

This standard applies to equipment with a socket for an external antenna and to equipment with an integral antenna.

In the case of equipment which is intended for use with either an integral antenna or an external antenna, the equipment shall be measured as equipment intended for use with an external antenna and shall meet the appropriate limits. In addition to this, the transmitter characteristics:

- transmitter carrier power,
- spurious emissions of the transmitter,

and the receiver characteristic:

- spurious radiations of the receiver,

shall be measured as for equipment for use with an integral antenna and the appropriate limits shall be met.

2 Normative references

- [1] CEPT Recommendation T/R 20-02 (1972, with subsequent amendments): "Low-power radio transmitter-receivers intended to provide voice radiocommunications in the 27 MHz band (PR 27 Radio Equipment)"
- [2] CEPT Recommendation T/R 20-07 (1982, with subsequent amendment): "Free circulation for use in different countries, of low-power mobile and portable transmitter-receivers in the 27 MHz band (PR 27 equipment Recommendation T/R 20-02)"
- [3] CCITT Recommendation O.41 (1988): "Psophometer for use on the telephone-type circuits"
- [4] CCITT Recommendation T/R 20-09 (1990): "PR27 radio equipment intended to provide short-range voice radiocommunication in the 27 MHz band"

3 Definition, abbreviations and symbols

3.1 Definitions

For the purpose of this standard the following definitions apply.

Base station

Equipment fitted with an antenna socket, for use with an external antenna, and intended for use in a fixed location.

Mobile station

Mobile equipment fitted with an antenna socket, for use with an external antenna, normally used in a vehicle or as a transportable station.

Handportable station

Equipment either fitted with an antenna socket or an integral antenna, or both, normally used on a stand-alone basis, to be carried on a person or held in the hand.

Integral antenna

An antenna designed to be connected to the equipment without the use of a 50 ohm external connector and considered to be part of the equipment. An integral antenna may be fitted internally or externally to the equipment.

Angle modulation

Angle modulation with an audio pre-emphasis characteristic for the transmitter and an audio de-emphasis characteristic for the receiver.

3.2 Abbreviations

SND/ND	(signal + noise + distortion)/(noise + distortion)
dBc	dB relative to the carrier power
RF	radio frequency
IF	intermediate frequency
Tx	transmitter
Rx	receiver

3.3 Symbols

E_o	reference field strength, annex A
R_o	reference distance, annex A

4 General

4.1 Presentation of equipment for testing purposes

- a) The manufacturer shall provide a production model of the equipment for type approval testing. If type approval is given on the basis of tests on a preliminary model, the corresponding production models shall be identical in all respects with the preliminary model tested;
- b) Tests shall be carried out on the highest and lowest channel within the switching range of the equipment and on a channel near the middle of the switching range. The switching range of the receiver and transmitter shall be declared by the manufacturer. The switching range is the maximum frequency range over which the receiver or the transmitter can be operated without reprogramming or realignment. In the case of equipment fitted with one channel only, all tests are carried out on that channel.

In the case of equipment fitted with two channels, all tests are carried out on both channels.

4.2 Mechanical and electrical design

4.2.1 General

The equipment submitted by the manufacturer or his representative, shall be designed, constructed and manufactured in accordance with sound engineering practice, and with the aim to minimise harmful interference to other equipment and services.

4.2.2 Controls

Those controls which if maladjusted might increase the interfering potentialities of the equipment shall not be accessible to the user.

4.2.3 Marking

The equipment shall be marked in a visible place. This marking shall be legible, tamperproof and durable.

The marking shall include:

- a) the name of the manufacturer or his trade mark;
- b) the type number of designation and serial number;
- c) the type approval number (when allocated by appropriate authorities);
- d) the type approval mark as stated in CEPT Recommendations T/R 20-07 [2] and T/R 20-09 [4].

4.3 Interpretation of the measurement results

The interpretation of the results recorded in a test report when making the measurements described in this standard shall be as follows:

- a) the measured value related to the corresponding limit will be used to decide whether an equipment meets the minimum requirements of the standard;
- b) the inclusion in the test report of the actual measurement uncertainty for each particular measurement is also required;
- c) the values, of the actual measurement uncertainty shall be, for each measurement, equal to or lower than the figures in Clause 10 (table of measurement uncertainty).

NOTE: This procedure for using the Maximum Acceptable Uncertainty Value is valid until superseded by other publications of ETSI covering this subject.

The use of the measured value for comparison with the limit value has been chosen because there is no definitive standard for specifying the measurement uncertainty agreed at the time of publication of this standard. Therefore the measurement uncertainty shall be used as a quality measure of the actual measurement. The use of the Measurement Uncertainty values shall be used by Accreditation Authorities during their accreditation procedures to ensure compliance/conformity with the requirements of type testing to ETSI Standards.

5 Technical characteristics

5.1 Common characteristics

5.1.1 Frequency band

The maximum operating frequency band shall be from 26.960 MHz to 27.410 MHz. Equipment may operate on one or more channels up to a maximum of 40 channels.

5.1.2 Carrier frequencies and channel numbers.

The following carrier frequencies are available.

Carrier frequencies	Channel Number	Carrier frequencies	Channel Number
26.965 Mhz	1	27.215 MHz	21
26.975 Mhz	2	27.225 MHz	22
26.985 Mhz	3	27.235 MHz	24
27.005 Mhz	4	27.245 MHz	25
27.015 Mhz	5	27.255 MHz	23
27.025 Mhz	6	27.265 MHz	26
27.035 Mhz	7	27.275 MHz	27
27.055 Mhz	8	27.285 MHz	28
27.065 Mhz	9	27.295 MHz	29
27.075 Mhz	10	27.305 MHz	30
27.085 Mhz	11	27.315 MHz	31
27.105 Mhz	12	27.325 MHz	32
27.115 Mhz	13	27.335 MHz	33
27.125 Mhz	14	27.345 MHz	34
27.135 Mhz	15	27.355 MHz	35
27.155 Mhz	16	27.365 MHz	36
27.165 Mhz	17	27.375 MHz	37
27.175 Mhz	18	27.385 MHz	38
27.185 Mhz	19	27.395 MHz	39
27.205 Mhz	20	27.405 MHz	40

Transmission and reception shall take place on the same channel (single frequency simplex mode).

5.1.3 Channel separation

The channel separation shall be 10 kHz.

5.1.4 Multi-channel equipment

Multi-channel equipment may be used, provided that such equipment is only designed for the channels indicated in subclause 5.1.2.

Precautions shall be taken against extension of the usable frequency range by the user. For instance the physical and electrical design of the channel switching system shall permit operation in not more than the channels indicated in subclause 5.1.2.

If for the determining of the transmitter frequency use is made of a synthesizer and/or of a phase locked loop (PLL) system, arbitrary input codes shall only lead to the channels indicated in subclause 5.1.2.

5.1.5 Type of modulation

Only angle modulation with appropriate pre-emphasis and de-emphasis shall be used.

5.1.6 Push-to-talk (ptt) and voice activated switch

Switching between the transmit and receive mode of operation shall only be possible by means of a non-locking ptt switch or by means of a non-locking voice activated switch.

If a voice activated switch is used it shall not respond to ambient acoustic noise. The noise threshold level adjustment shall not be accessible to the user.

5.1.7 Controls

Those controls which, if maladjusted, increase the risk of interference or improper functioning of the transceiver, shall not be immediately accessible to the user.

5.1.8 Combination with other equipment

The equipment shall not be combined with any other form of transmitting or receiving equipment. The equipment shall not be provided with any terminals or other connection points, internal or external, for modulating sources other than those required for either a separate or a built-in microphone, or for selective calling devices.

Terminals or other connecting points are permitted for the connection of external devices that shall not modulate the transmitters (e.g. a voice synthesiser device to give an aural indication of channel).

Equipment fitted with a selective calling device shall meet the requirements of subclause 5.2.6 for transmitter conducted and radiated spurious emissions with the device in operation.

5.2 Transmitter parameter limits

5.2.1 Frequency error

For the definition and the measuring method see subclause 8.1. The frequency error shall not exceed 0.6 kHz.

5.2.2 Power

For the definition and the measuring method see subclause 8.2. Both the transmitter carrier power, and the effective radiated power of an equipment with an integral antenna, shall not exceed 4 watts. The equipment shall be constructed in such a way that an increase of output power cannot easily be achieved by actions undertaken by the user of the equipment.

5.2.3 Frequency deviation

For the definition and measurement method see subclause 8.3. The maximum permissible frequency deviation shall be ± 2 kHz.

5.2.4 Unwanted amplitude modulation

For the measurement method see subclause 8.4.1. The maximum permitted unwanted amplitude modulation shall not exceed 5%.

5.2.5 Adjacent channel power

For the definition and measuring method see subclause 8.5. The adjacent channel power shall not exceed a value of 20 microwatts.

5.2.6 Spurious emissions of the transmitter

For the definition and measuring method see subclause 8.6. In the frequency bands

47 MHz	to	68 MHz
87.5 MHz	to	118 MHz
174 MHz	to	230 MHz
470 MHz	to	862 MHz

the power of conducted and radiated spurious emissions shall not exceed 4 nanowatts for the transmitter operating and 2 nanowatts for the transmitter in the stand-by condition.

The power of any spurious emissions on other frequencies in the specified ranges shall not exceed the following limits.

a) conducted emissions

Frequency range	9 kHz to 1 GHz	above 1 GHz to 2 GHz
Tx operating	0,25 microwatt (-36 dBm)	1 microwatt (-30 dBm)
Tx stand-by	2 nanowatts (-57 dBm)	20 nanowatts (-47 dBm)

b) radiated emissions

Frequency range	25 MHz to 1 GHz	above 1 GHz to 2GHz
Tx operating	0,25 microwatt (-36 dBm)	1 microwatt (-30 dBm)
Tx stand-by	2 nanowatts (-57 dBm)	20 nanowatts (-47 dBm)

In the case of radiated measurements for handportable stations the following conditions apply:

- integral antenna : the normal antenna shall be connected;
- external antenna socket: an artificial load shall be connected to the socket for the test.

5.2.7 Transient frequency behaviour of the transmitter

For the definition and measurement method see subclause 8.7.

The transient periods are shown in figure 4, subclause 8.7 and are as follows:

t_1 5.0 ms

t_2 20.0 ms

t_3 5.0 ms

During the periods t_1 and t_3 the frequency difference shall not exceed the value of 1 channel separation.

During the period t_2 the frequency difference shall not exceed the value of half a channel separation.

In the case of handportable stations, the frequency deviation during sub t_1 and sub t_3 may be greater than one channel. The corresponding plot of frequency versus time during t_1 and t_3 shall be recorded in the test report.

This measurement applies only to equipment with an external antenna connector.

5.2.8 Synthesisers and Phase Locked Loop (PLL) systems

If - for determining the transmitter frequency - use is made of a synthesiser and/or a PLL system, the transmitter shall be inhibited when synchronisation is absent.

5.3 Receiver parameter limits

5.3.1 Maximum usable sensitivity

For the definition and measuring method see subclause 9.1. The maximum usable sensitivity shall not exceed an e.m.f. of 6 dB μ V. This requirement only applies to equipment with an external antenna connector.

5.3.2 Adjacent channel selectivity

For the definition and measuring method see subclause 9.2. The adjacent channel selectivity shall not be less than of 60 dB. This requirement only applies to equipment with an external antenna connector.

5.3.3 Intermodulation response rejection

For the definition and measurement method see subclause 9.3. The intermodulation response rejection ratio shall not be less than 54 dB. This requirement only applies to equipment with an external antenna connector.

5.3.4 Spurious radiations

For the definition and the measurement method see subclause 9.4. The power of any spurious radiation shall not exceed the values in the following tables.

a) conducted components

Frequency range	9 kHz to 1 GHz	above 1 GHz to 2 GHz
Limit	2 nanowatts (-57 dBm)	20 nanowatts (-47 dBm)

b) radiated components

Frequency range	25 MHz to 1 GHz	above 1 GHz to 2 GHz
Limit	2 nanowatts (-57 dBm)	20 nanowatts (-47 dBm)

6 Test conditions, power sources and ambient temperatures

6.1 Normal and extreme test conditions

Type approval tests shall be made under normal test conditions, and also, where stated, under extreme test conditions.

6.2 Test power source

During type approval tests the power source of the equipment shall be replaced by a test power source capable of producing normal and extreme test voltages as specified in subclauses 6.3.2 and 6.4.2. The internal impedance of the test power source shall be low enough for its effect on the test results to be negligible. For the purpose of tests, the voltage of the power source shall be measured at the input terminals of the equipment.

If the equipment is provided with a permanently connected power cable, the test voltage shall be that measured at the point of connection of the power cable to the equipment.

For battery operated equipment, the battery should be removed and the test power source shall be applied as close to the battery terminals as practicable.

During tests the power source voltages shall be maintained within a tolerance of $\pm 3\%$ relative to the voltage at the beginning of each test.

6.3 Normal test conditions

6.3.1 Normal temperature and humidity

The normal temperature and humidity conditions for tests shall be any convenient combination of temperature and humidity within the following ranges:

- temperature +15 C to +35C
- relative humidity 20% to 75%

When it is impracticable to carry out the tests under the conditions stated above, a note to this effect, stating the actual temperature and relative humidity during the tests, shall be added to the test report.

6.3.2 Normal test power source

6.3.2.1 Mains voltage and frequency

The normal test voltage for equipment to be connected to the mains shall be the nominal mains voltage. For the purpose of this standard, the nominal voltage shall be the declared voltage or any of the declared voltages for which the equipment was designed.

The frequency of the test power source corresponding to the AC mains shall be between 49 and 51 Hz.

6.3.2.2 Regulated lead-acid battery power sources on vehicles

When the radio equipment is intended for operation from the usual types of regulated lead-acid battery power source of vehicles, the normal test voltage shall be 1.1 times the nominal voltage of the battery (6 volts, 12 volts etc).

6.3.2.3 Other power sources

For operation from other power sources or types of battery (primary or secondary), the normal test voltage shall be that declared by the equipment manufacturer.

6.4 Extreme test conditions

6.4.1 Extreme temperatures

For tests at extreme temperatures, measurements shall be made in accordance with the procedures specified in subclause 6.5, at the upper and lower temperatures of -10° and $+55^{\circ}\text{C}$ respectively.

6.4.2 Extreme test source voltages

6.4.2.1 Mains voltage

The extreme test voltage for equipment to be connected to an AC mains source shall be the nominal voltage $\pm 10\%$.

6.4.2.2 Regulated lead-acid battery power sources on vehicles

When the equipment is intended for operation from the usual types of regulated lead-acid battery power sources of vehicles the extreme test voltages shall be 1.3 and 0.9 times the nominal voltage of the battery (6 volts, 12 volts etc).

6.4.2.3 Power sources using other types of battery

The lower extreme test voltages for equipment with power sources using the following batteries shall be:

- for the Leclanché or the lithium type of battery: 0.85 times the nominal voltage of the battery;
- for the mercury or nickel-cadium type of battery: 0.9 times the nominal voltage of the battery.

No upper extreme test voltages apply.

6.4.2.4 Other power sources

For equipment using other power sources, or capable of being operated from a variety of power sources, the extreme test voltages shall be those agreed between the equipment manufacturer and the testing laboratory and shall be recorded in the test report.

6.5 Procedure for tests at extreme temperatures

6.5.1 Test procedure

Before measurements are made the equipment shall have reached thermal balance in the test chamber. The equipment shall be switched off during the temperature stabilising period. If the thermal balance is not checked by measurements, a temperature stabilising period of at least one hour, or such period as may be decided by the testing laboratory, shall be allowed. The sequence of measurements shall be chosen, and the humidity content in the test chamber shall be controlled so that excessive condensation does not occur.

Before tests at the upper temperature the equipment shall be placed in the test chamber and left until thermal balance is attained. The equipment shall then be switched on for one minute in the transmit condition, followed by four minutes in the receive condition, after which the equipment shall meet the specified requirements. For tests at the lower temperatures the equipment shall be left in the test chamber until thermal balance is attained, then switched to the standby or receive condition for one minute after which the equipment shall meet the specified requirements.

7 General conditions

7.1 Arrangements for test signals applied to the receiver input

Sources of test signals for application to the receiver input shall be connected in such a way that the impedance presented to the receiver input is 50 ohms.

This requirement shall be met irrespective of whether one or more signals are supplied to the receiver simultaneously.

The levels of the test signals shall be expressed in terms of the e.m.f. at the receiver input terminals.

The effects of any intermodulation products and noise produced in the signal generators should be negligible. The test generators shall be substantially free from static amplitude modulation.

7.2 Receiver mute or squelch facility

If the receiver is equipped with a mute or squelch circuit, this shall be made inoperative for the duration of the type approval tests.

7.3 Receiver rated audio output power

The rated audio output power shall be the maximum power, declared by the manufacturer, for which all the requirements of this standard are met. With normal test modulation (subclause 7.4), the audio power shall be measured in a resistive load, simulating the load with which the receiver normally operates. The value of this load shall be declared by the manufacturer.

7.4 Normal test modulation

For normal test modulation, the modulation frequency shall be 1 kHz and the resulting frequency deviation shall be ± 1.2 kHz.

7.5 Artificial antenna

Tests on the transmitter shall be carried out with a non-reactive non-radiating load of 50 ohms connected to the antenna terminals.

Tests on the transmitter requiring the use of the test fixture shall be carried out with a 50 ohm non-reactive non-radiating load connected to the test fixture.

7.6 Test fixture

In the case of equipment intended for use with an integral antenna, the manufacturer may be required to supply a test fixture, suitable to allow relative measurements to be made on the submitted sample.

The test fixture shall provide means of making external connection to the audio frequency input and radio frequency output and of replacing the power source by external power supplies.

The test fixture shall provide a 50 ohm radio frequency terminal at the working frequencies of the equipment.

The performance characteristics of this test fixture under normal and extreme conditions are subject to the approval of the test laboratory.

The characteristics of interest to the test laboratory will be that:

- a) the coupling loss shall not be greater than 30 dB;
- b) the variation of coupling loss with frequency shall not cause errors exceeding 2 dB in measurements using the test fixture;
- c) the coupling device shall not include any non-linear elements; the test laboratory may provide its own test fixture.

7.7 Arrangement for test signals at the input of the transmitter

The transmitter audio frequency modulation signal shall be supplied by a generator applied at the connections of the microphone insert, unless otherwise stated.

7.8 Test site and general arrangements for radiated measurements

For guidance on radiation test sites see annex A. Detailed descriptions of the radiated measurement arrangements are included in this annex.

8 Method of measurement for transmitter parameters

8.1 Frequency error

8.1.1 Definition

The frequency error of the transmitter is the difference between the measured carrier frequency and its nominal value.

8.1.2 Method of measurement

The carrier frequency shall be measured in the absence of modulation, with the transmitter connected to an artificial antenna (subclause 7.5). Equipment with an integral antenna shall be placed in the test fixture (subclause 7.6) connected to the artificial antenna (subclause 7.5). The measurement shall be made under normal test conditions (subclause 6.3) and repeated under extreme test conditions (subclauses 6.4.1 and 6.4.2 applied simultaneously).

8.2 Transmitter carrier power

8.2.1 Definition

The transmitter carrier power is the mean power delivered to the artificial antenna during a radio frequency cycle, or in the case of equipment with integral antenna the effective radiated power in the direction of maximum field strength under the specified conditions of measurement (subclause 7.8) in the absence of modulation.

8.2.2 Method of measurement (for equipment other than equipment with integral antenna only)

The transmitter shall be connected to an artificial antenna (subclause 7.5), and the power delivered to this artificial antenna shall be measured.

The measurements shall be made under normal test conditions (subclause 6.3) and extreme test conditions (subclauses 6.4.1 and 6.4.2 applied simultaneously).

8.2.3 Method of measurement for equipment with integral antenna

On a test site selected from annex A the equipment shall be placed on the support in the following position:

- a) for equipment with an internal antenna, it shall stand so that the axis of the equipment which in its normal use is closest to the vertical, shall be vertical;
- b) for equipment with a rigid external antennas, the antenna shall be vertical;
- c) for equipment with a non-rigid external antenna, the antenna shall be extended vertically upwards by a non-conducting support.

The test antenna shall be orientated for vertical polarisation and the length of the test antenna shall be chosen to correspond to the frequency of the transmitter. The output of the test antenna shall be connected to a measuring receiver. The transmitter shall be switched on without modulation and the measuring receiver shall be tuned to the frequency of the transmitter under test. The test antenna shall be raised and lowered through the specified range of height until a maximum signal level is detected by the measuring receiver.

The transmitter shall then be rotated through 360° in the horizontal plane until the maximum signal level is detected by the measuring receiver.

The maximum signal level detected by the measuring receiver shall be noted.

The transmitter shall be replaced by a substitution antenna as defined in subclause A.2.3.

The substitution antenna shall be orientated for vertical polarisation and the length of the substitution antenna shall be adjusted to correspond to the frequency of the transmitter.

The substitution antenna shall be connected to a calibrated signal generator.

The input attenuator setting of the measuring receiver shall be adjusted in order to increase the sensitivity of the measuring receiver.

The test antenna shall be raised and lowered through the specified range of height to ensure that the maximum signal is received.

The input signal to the substitution antenna shall be adjusted to the level that produces a level detected by the measuring receiver, that is equal to the level noted while the transmitter radiated power was measured, corrected for the change of input attenuator setting of the measuring receiver.

The measurement shall be repeated with the test antenna and the substitution antenna orientated for horizontal polarisation.

The measure of the effective radiated power is the larger of the two power levels recorded, at the input to the substitution antenna, corrected for gain of the antenna if necessary.

8.3 Maximum frequency deviation

The maximum frequency deviation is the maximum difference between the instantaneous frequency of the modulated radio frequency signal and the carrier frequency in the absence of modulation.

8.3.1 Maximum permissible frequency deviation

8.3.1.1 Definition

The maximum permissible frequency deviation is the maximum value of frequency deviation.

8.3.1.2 Method of measurement

The frequency deviation shall be measured at the output of the transmitter connected via a 50 ohm power attenuator, to a deviation meter capable of measuring the maximum deviation, including that due to any harmonics and intermodulation products which may be generated in the transmitter.

The modulation frequency of the test signal shall be varied between the lowest frequency considered to be appropriate, and 10 kHz. The level of this test signal shall be 20 dB above the level required to give a frequency deviation of 1.2 kHz at an audio frequency of 1250 Hz.

8.4 Unwanted amplitude modulation

The unwanted amplitude modulation is measured with the transmitter fully modulated to the maximum permissible frequency deviation.

8.4.1 Method of measurement

The amplitude modulation shall be measured at the output of the transmitter connected via a 50 ohm power attenuator to an amplitude modulation meter capable of measuring the maximum amplitude modulation including that due to any harmonics and intermodulation products which may be generated in the transmitter. The modulation frequency of the test signal shall be varied between the lowest frequency considered appropriate, and 10 kHz. The level of this test signal shall be 20 dB above the level required to give a frequency deviation of 1.2 kHz at an audio frequency of 1250 Hz.

8.5 Adjacent channel power

8.5.1 Definition

The adjacent channel power is that part of the total output power of a transmitter, modulated under defined conditions, which falls within a specified bandwidth centered on the nominal frequency of either of the adjacent channels. This power is the sum of the mean power produced by the modulation process and by residual modulation caused by hum and noise of the transmitter.

8.5.2 Method of measurement

The adjacent channel power shall be measured with a power measuring receiver which conforms with the requirements given in Annex B and is referred to in this clause as the "receiver".

- a) The transmitter shall be operated at the carrier power measured in subclause 8.2 under normal test conditions (subclause 6.3). The output of the transmitter shall be linked to the input of the "receiver" by a connecting device such that the impedance presented to the transmitter is 50 ohms and the level at the "receiver" input is appropriate. For equipment with an integral antenna the connecting device is a test fixture as described in subclause 7.6;
- b) With the transmitter unmodulated, the tuning of the "receiver" shall be adjusted so that a maximum response is obtained. This is the 0 dB reference point. The "receiver" variable attenuator setting and the reading of the rms value indicator shall be recorded;
- c) The tuning of the "receiver" shall be adjusted away from the carrier so that the "receiver" - 6 dB response nearest to the transmitter carrier frequency is located at a displacement of 5.75 kHz from the nominal carrier frequency;
- d) The transmitter shall be modulated by a test signal of 1250 Hz at a level which is 20 dB higher than that required to produce a deviation of ± 1.2 kHz;
- e) The "receiver" variable attenuator shall be adjusted to obtain the same reading as in step b) or a known relation to it;
- f) The ratio of adjacent channel power to carrier power is the difference between the attenuator settings in steps b) and e), corrected for any differences in the reading of the rms value indicator;
- g) The measurement shall be repeated with the "receiver" tuned to the other side of the carrier;
- h) If the equipment has a microphone socket the measurement shall be repeated with an input of 1.5 volts at 1250 Hz at this socket.

8.6 Spurious emissions

8.6.1 Definition

Spurious emissions are emissions at frequencies other than those of the carrier and sidebands associated with normal test modulation. The level of spurious emissions shall be measured as:

- a) power level in a specified load (conducted spurious emission), and
- b) their effective radiated power when radiated by the cabinet and structure of the equipment (cabinet radiation), or
- c) their effective radiated power when radiated by the cabinet and the integral antenna, in the case of handportable equipment fitted with such an antenna and no external RF connector.

8.6.2 Method of measuring the power level in a specified load, subclause 8.6.1 (a)

The transmitter shall be connected to a 50 ohm power attenuator. The output of the power attenuator shall be connected to a measuring receiver.

The transmitter shall be switched on without modulation, and the measuring receiver, annex A, shall be tuned over the frequency range 9 kHz to 2 GHz.

At each frequency at which a spurious component is detected, the power level shall be recorded as the conducted spurious emission level delivered into the specified load, except for the channel on which the transmitter is intended to operate and the adjacent channels.

The measurements shall be repeated with the transmitter on stand-by.

8.6.3 Method of measuring the effective radiated power, subclause 8.6.1 (b)

On a test site, selected from annex A, the equipment shall be placed at the specified height on the appropriate support and in the position closest to normal use as declared by the manufacturer.

The transmitter antenna connector shall be connected to an artificial antenna, subclause 7.5.

The test antenna shall be orientated for vertical polarisation and the length of the test antenna shall be chosen to correspond to the instantaneous frequency of the measuring receiver.

The output of the test antenna shall be connected to a measuring receiver. The transmitter shall be switched on without modulation, and the measuring receiver shall be tuned over the frequency range 25 MHz to 2 GHz, except for the channel on which the transmitter is intended to operate and its adjacent channels.

At each frequency at which a spurious component is detected, the test antenna shall be raised and lowered through the specified range of heights until the maximum signal level is detected on the measuring receiver.

The transmitter shall then be rotated through 360° in the horizontal plane, until the maximum signal level is detected by the measuring receiver.

The maximum signal level detected by the measuring receiver shall be noted.

The transmitter shall be replaced by a substitution antenna as defined in subclause A.2.3.

The substitution antenna shall be orientated for vertical polarisation and the length of the substitution antenna shall be adjusted to correspond to the frequency of the spurious component detected.

The substitution antenna shall be connected to a calibrated signal generator.

The frequency of the calibrated signal generator shall be set to the frequency of the spurious component detected.

The input attenuator setting of the measuring receiver shall be adjusted in order to increase the sensitivity of the measuring receiver, if necessary.

The test antenna shall be raised and lowered through the specified range of heights to ensure that the maximum signal is received.

The input signal to the substitution antenna shall be adjusted to the level that produces a level detected by the measuring receiver, that is equal to the level noted while the spurious component was measured, corrected for the change of input attenuator setting of the measuring receiver.

The input level to the substitution antenna shall be recorded as power level, corrected for the change of input attenuator setting of the measuring receiver.

The measurement shall be repeated with the test antenna and the substitution antenna orientated for horizontal polarisation.

The measure of the effective radiated power of the spurious components is the larger of the two power levels recorded for each spurious component at the input to the substitution antenna, corrected for the gain of the antenna if necessary.

The measurements shall be repeated with the transmitter on stand-by.

8.6.4 Method of measuring the effective radiated power, subclause 8.6.1 (c)

The method of measurement shall be performed according to subclause 8.6.3, except that the transmitter output shall be connected to the integral antenna and not to an artificial antenna.

8.7 Transient frequency behaviour of the transmitter

8.7.1 Definitions

The transient frequency behaviour of the transmitter is the variation with respect to time of the transmitter frequency distance from the nominal frequency of the transmitter when the RF output power is switched on and off.

t_{on} : according to the method of measurement described in subclause 8.7.2 the switch-on instant t_{on} of a transmitter is defined by the condition when the output power, measured at the antenna terminal, exceeds 0.1% of the nominal power.

t_1 : period of time starting at t_{on} and finishing according to subclause 5.2.7.

t_2 : period of time starting at end of t_1 and finishing according to subclause 5.2.7.

t_{off} : switch-off instant defined by the condition when the nominal power falls below 0.1% of the nominal power.

t_3 : period of time finishing at t_{off} and starting according to subclause 5.2.7.

8.7.2 Method of measurement

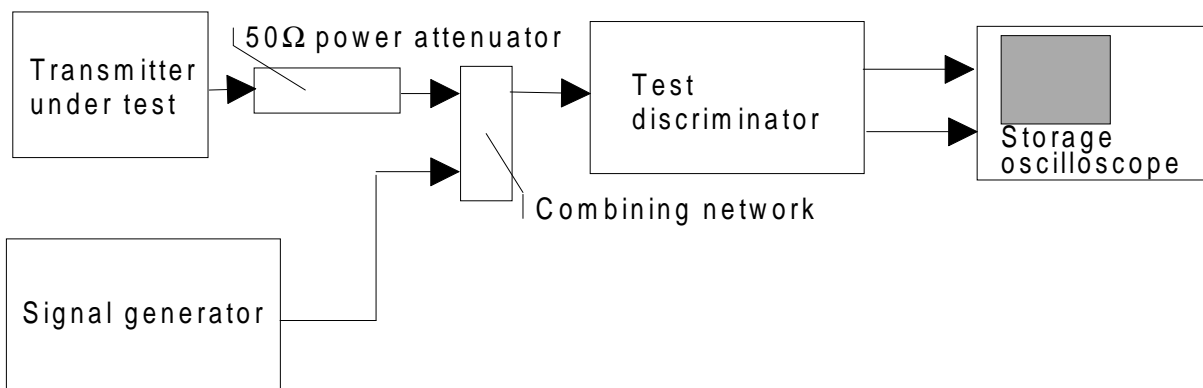

Figure 3: Measurement arrangement.

The measurement arrangement shown in figure 3 shall be used. Two signals shall be connected to the test discriminator via a combining network, subclause 7.1.

The transmitter shall be connected to a 50 ohm power attenuator. The output of the power attenuator shall be connected to the test discriminator via one input of the combining network.

A test signal generator shall be connected to the second input of the combining network.

The test signal shall be adjusted to the nominal frequency of the transmitter.

The test signal shall be modulated by a frequency of 1 kHz with a deviation equal to ± 10 kHz. The test signal level shall be adjusted to correspond to 0.1% of the power of the transmitter under test measured at the input of the test discriminator. This level shall be maintained throughout the measurement. The amplitude

difference (ad) and the frequency difference (fd) output of the test discriminator shall be connected to a storage oscilloscope. The storage oscilloscope shall be set to display the channel corresponding to the (fd) input up to ± 1 channel frequency difference, corresponding to the relevant channel separation, from the nominal frequency. The storage oscilloscope shall be set to a sweep rate of 10 ms/division and set so that the triggering occurs at 1 division from the left edge of the display. The display will show the 1 kHz test signal continuously.

The storage oscilloscope shall then be set to trigger on the channel corresponding to the amplitude difference (ad) input at a low input level, rising.

The transmitter shall then be switched on, without modulation, to produce the trigger pulse and a picture on the display.

The result of the change in the ratio of power between the test signal and the transmitter output will, due to the capture ratio of the test discriminator, produce two separate sides on the picture, one showing the 1 kHz test signal, the other the frequency difference of the transmitter versus time.

The moment when the 1 kHz test signal is completely suppressed is considered to provide t_{on} . The periods of time t_1 and t_2 as defined in subclause 5.2.7, shall be used to define the appropriate template. During the period of time t_1 and t_2 the frequency difference shall not exceed the values given in subclause 5.2.7. The frequency difference, after the end of t_2 , shall be within the limit of the frequency error, subclause 5.2.1. The result shall be recorded as frequency difference versus time.

The transmitter shall remain switched on. The storage oscilloscope shall be set to trigger on the channel corresponding to the amplitude difference (ad) input at a high input level, decaying and set so that the triggering occurs at 1 div. from the right edge of the display. The transmitter shall then be switched off. The moment when the 1 kHz test signal starts to rise is considered to provide t_{off} .

The period of time t_3 as defined in subclause 5.2.7 shall be used to define the appropriate template. During the period of time t_3 the frequency difference shall not exceed the values given in subclause 5.2.7. Before the start of t_3 the frequency difference shall be within the limit of the frequency error, subclause 5.2.1. The result shall be recorded as frequency difference versus time.

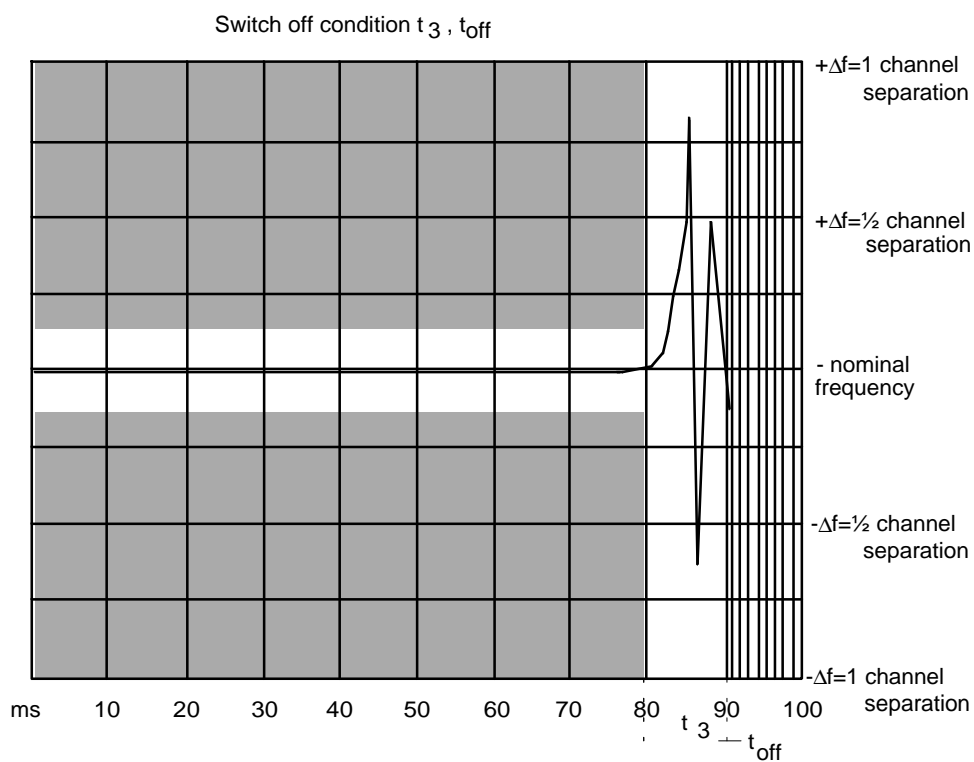
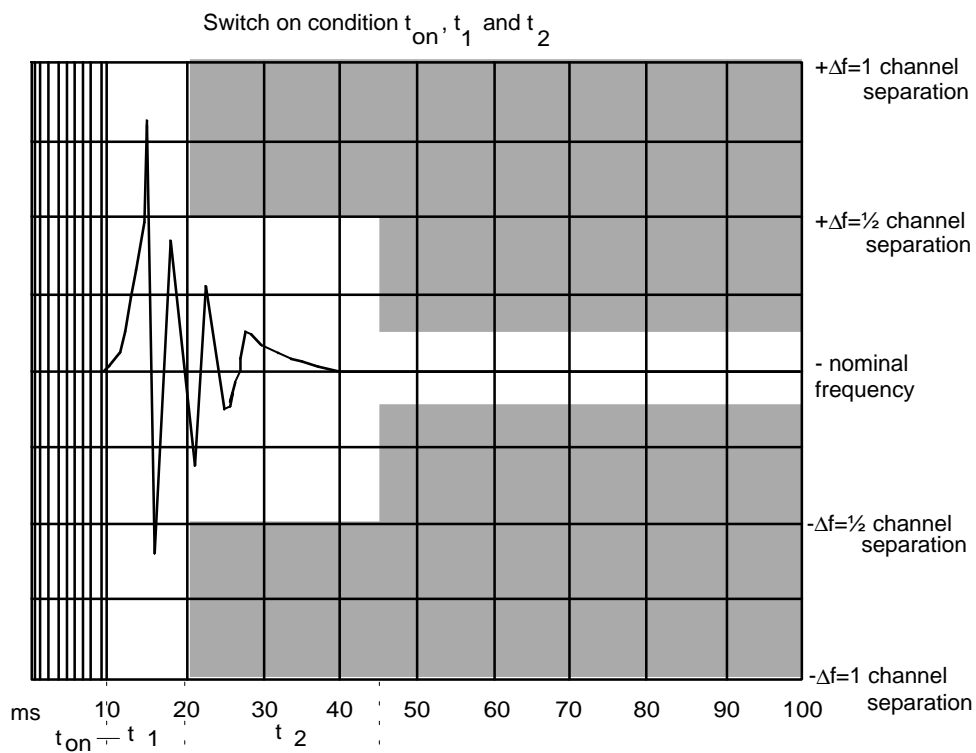

Figure 4: Storage oscilloscope view t_1 , t_2 and t_3

9 Methods of measurement for receiver parameters

9.1 Maximum usable sensitivity

This measurement applies only to equipment with an external antenna connector.

9.1.1 Definition

The maximum usable sensitivity of the receiver is the minimum level of signal (e.m.f.) at the receiver input, at the nominal frequency of the receiver and with normal test modulation, subclause 7.4, which will produce:

- an audio frequency output power of at least 50% of the rated power output, subclause 7.3, and
- a SND/ND ratio of 20 dB, measured at the receiver output through a telephone psophometric weighting network as described in CCITT Recommendation O.41 [3].

9.1.2 Method of measuring the SND/ND ratio

The test signal, at the nominal frequency of the receiver, with normal test modulation, subclause 7.4, at an e.m.f. of 6 dB μ V, value of the limit for the maximum usable sensitivity, shall be applied to the receiver input connector. An audio frequency output load, a SINAD meter and a psophometric telephone weighting network as mentioned in subclause 9.1.1, shall be connected to the receiver output terminals. Where possible, the receiver volume control shall be adjusted to give at least 50% of the rated output power, subclause 7.3 or, in the case of stepped volume controls, to the first step that provides an output power of at least 50% of the rated output power.

The test signal input level shall be reduced until a SND/ND ratio of 20 dB is obtained. The test signal input level under these conditions is the value of the maximum usable sensitivity. The measurement shall be made only under normal test conditions.

9.2 Adjacent channel selectivity

This measurement applies only to equipment with an external antenna connector.

9.2.1 Definition

The adjacent channel selectivity is the capability of the receiver to receive a wanted modulated signal at the nominal frequency without exceeding a given degradation due to the presence of an unwanted modulated signal in the adjacent channel.

9.2.2 Method of measurement

The two input signals shall be connected to the receiver via a combining network, subclause 7.1.

The wanted test signal, at the nominal frequency of the receiver, with normal test modulation, subclause 7.4, at an e.m.f. of 6 dB μ V, value of the limit for the maximum usable sensitivity, shall be applied to the receiver input connector via one input of the combining network.

The unwanted test signal, at a frequency of 10 kHz above the nominal frequency of the receiver, modulated with a frequency of 400 Hz at a deviation of ± 1.2 kHz shall be applied to the receiver input connector via the second input of the combining network.

The amplitude of the unwanted test signal shall be adjusted until the SND/ND ratio, psophometrically weighted, at the output of the receiver is reduced to 14 dB.

The measure of the adjacent channel selectivity is the ratio in dB of the level of the unwanted test signal to the level of the wanted test signal at the receiver input for which the specified reduction in SND/ND ratio occurs. This ratio shall be noted.

The measurement shall be repeated with an unwanted signal at the frequency of the channel below that of the wanted signal.

The two noted ratios shall be recorded as the upper and lower adjacent channel selectivity.

The measurement shall be made under normal test conditions.

9.3 Intermodulation response rejection

This measurement only applies to equipment with an external antenna connector.

9.3.1 Definition

The intermodulation response rejection is the capability of a receiver to receive a wanted modulated signal at the nominal frequency without exceeding a given degradation due to the presence of two or more unwanted signals with a specific frequency relationship to the wanted signal frequency.

9.3.2 Method of measurement

Three input signals shall be connected to the receiver via a combining network, subclause 7.1.

The wanted test signal (A), at the nominal frequency of the receiver, with normal test modulation, subclause 7.4, at an e.m.f. of 6 dB μ V, value of the limit for the maximum usable sensitivity, shall be applied to the receiver input connector via one input of the combining network.

The unwanted test signal (B), at the frequency 20 kHz above the nominal frequency of the receiver, without modulation, shall be applied to the receiver input connector via the second input of the combining network.

The unwanted test signal (C), at the frequency 40 kHz above the nominal frequency of the receiver, modulated with a frequency of 400 Hz at a deviation of ± 1.2 kHz, shall be applied to the receiver input connector via the third input of the combining network.

The amplitude of the unwanted test signals (B) and (C) shall be maintained equal and adjusted until the SND/ND ratio, psophometrically weighted, at the output of the receiver is reduced to 14 dB.

The measure of the intermodulation response rejection is the ratio in dB of the level of the unwanted test signals to the level of the wanted test signal at the receiver input for which the specified reduction in SND/ND ratio occurs. This ratio shall be recorded.

The measurement shall be repeated with the unwanted signal from signal generator (B) at a frequency 40 kHz above the wanted signal and with the unwanted signal from signal generator (C) at a frequency 80 kHz above the wanted signal.

The two sets of measurements described above shall be repeated with the unwanted signals below the nominal frequency of the receiver by the specified amounts.

9.4 Spurious radiations

9.4.1 Definition

Spurious radiations from the receiver are components at any frequency, radiated by the equipment and antenna.

The level of spurious radiations shall be measured by:

- a) their power level in a specified load (conducted spurious emission), and
- b) their effective radiated power when radiated by the cabinet and structure of the equipment (cabinet radiation), or
- c) their effective radiated power when radiated by the cabinet and the integral antenna, in the case of handportable equipment fitted with such an antenna and no external RF connector.

9.4.2 Method of measuring the power level in a specified load, subclause 9.4.1 (a)

The receiver shall be connected to a 50 ohm attenuator. The output of the attenuator shall be connected to a measuring receiver. The receiver shall be switched on, and the measuring receiver shall be tuned over the frequency range 9 kHz to 2 GHz.

At each frequency at which a spurious component is detected, the power level shall be recorded as the spurious level delivered into the specified load.

9.4.3 Method of measuring the effective radiated power, subclause 9.4.1 (b)

On a test site, selected from annex A, the equipment shall be placed at the specified height on the appropriate support and in the position closest to normal use as declared by the manufacturer. The receiver antenna connector shall be connected to an artificial antenna, subclause 7.5.

The test antenna shall be orientated for vertical polarisation and the length of the test antenna shall be chosen to correspond to the instant frequency of the measuring receiver. The output of the test antenna shall be connected to a measuring receiver. The receiver shall be switched on and the measuring receiver shall be tuned over the frequency range 25 MHz to 4 GHz. At each frequency at which a spurious component is detected, the test antenna shall be raised and lowered through the specified range of height until a maximum signal level is detected by the measuring receiver. The receiver shall then be rotated through 360° in the horizontal plane until the maximum signal level is detected by the measuring receiver. The maximum signal level detected by the measuring receiver shall be noted.

The receiver shall be replaced by a substitution antenna as defined in subclause A.2.3. The substitution antenna shall be orientated for vertical polarisation and the length of the substitution antenna shall be adjusted to correspond to the frequency of the spurious component detected. The substitution antenna shall be connected to a calibrated signal generator. The frequency of the calibrated signal generator shall be set to the frequency of the spurious component detected.

The input attenuator setting of the measuring receiver shall be adjusted in order to increase the sensitivity of the measuring receiver, if necessary. The test antenna shall be raised and lowered through the specified range of height to ensure that the maximum signal is received. The input signal to the substitution antenna shall be adjusted to the level that produces a level noted while the spurious component was measured, corrected for the change of input attenuator setting of the measuring receiver. The input level to the substitution antenna shall be recorded as power level, corrected for the change of input attenuator setting of the measuring receiver.

The measurement shall be repeated with the test antenna and the substitution antenna orientated for horizontal polarisation.

The measure of the effective radiated power of the spurious components is the larger of the two power levels recorded for each spurious component at the input to the substitution antenna, corrected for the gain of the antenna if necessary.

9.4.4 Method of measuring the effective radiated power, subclause 9.4.1 (c)

The measurement shall be performed according to subclause 9.4.3, except that the receiver input shall be connected to the integral antenna and not to an artificial antenna.

10 Measurement uncertainty

ABSOLUTE MEASUREMENT UNCERTAINTIES: MAXIMUM VALUES

RF frequency	$< \pm 1 \times 10^{-7}$
RF power	$< \pm 0.75$ dB
Maximum frequency deviation:	
- within 300 Hz to 10 kHz of audio frequency	$< \pm 5$ %
Deviation limitation	$< \pm 5$ %
Adjacent channel power	$< \pm 5$ dB
Conducted emission of transmitter	$< \pm 4$ dB
Audio output power	$< \pm 0.5$ dB
Sensitivity at 20 dB SINAD	$< \pm 3$ dB
Conducted emission of receiver	$< \pm 3$ dB
Two-signal measurement, valid to 4 GHz	$< \pm 4$ dB
Three-signal measurement	$< \pm 3$ dB
Radiated emission of transmitter	$< \pm 6$ dB
Radiated emission of receiver	$< \pm 6$ dB
Transmitter transient time	$< \pm 20$ %
Transmitter transient frequency	$< \pm 250$ Hz

For the test methods laid down in this standard, these uncertainty figures are valid to a confidence level of 95% calculated according to the methods to be described in the ETSI Technical Report: "Uncertainties in the measurement of mobile radio equipment characteristics".

Annex A: Radiated measurement

A.1 Test sites and general arrangements for measurements involving the use of radiated fields

A.1.1 Outdoor test site

The outdoor test site shall be on a reasonably level surface or ground. At one point on the site, a ground plane of at least 5m diameter shall be provided. In the middle of this ground plane, a non-conducting support, capable of rotation through 360° in the horizontal plane, shall be used to support the test sample at 1.5m above the ground plane. The test site shall be large enough to allow the erection of a measuring or transmitting antenna at a distance of $\lambda/2$ or 3m whichever is the greater. The distance actually used shall be recorded with the results of the tests carried out on the site.

Sufficient precautions shall be taken to ensure that reflections from extraneous objects adjacent to the site and ground reflections do not degrade the measurements results.

A.1.1.2 Test site for handportable stations

The test site shall be on a reasonably level surface or ground. The test site shall be large enough to allow the erection of a measuring or transmitting antenna at a distance of at least 6 metres. The distance actually used shall be recorded with the results of the test carried out on the site.

At one point on the site, a ground plane of at least 5 metres diameter shall be provided. In the middle of this ground plane, a support, capable of rotation through 360° in the horizontal plane, shall be used to support the test sample at 1.5 metres above the ground plane. This support consists of a plastic tube, which is filled with salt water (9 grammes NaCl per litre). The tube shall have a length of 1.5 metres and an internal diameter of 10 ± 0.5 centimetres. The upper end of the tube is closed by a metal plate with a diameter of 15 centimetres, which is in contact with the water.

The sample shall be placed with its side of largest area on the metal plate. To meet the requirement that the antennas is vertical while maintaining contact with the metal plate, it may be necessary to use a second metal plate, attached to the first. This metal plate shall be 10 x 15cm in size and shall be hinged to the first plate by its 10cm edge in such a way that the angle between the plates can be adjusted between 0° and 90°. The hinge point shall be adjustable so that the centre of the sample can be placed above the centre of the circular plate. In the cast of samples whose length along the antenna axis is less than 15cm, the sample shall be arranged so that the base of the antennas is at the edge of the hinged plate.

Sufficient precautions shall be taken to ensure that reflections from extraneous objects adjacent to the site and ground reflections do not degrade the measurement results.

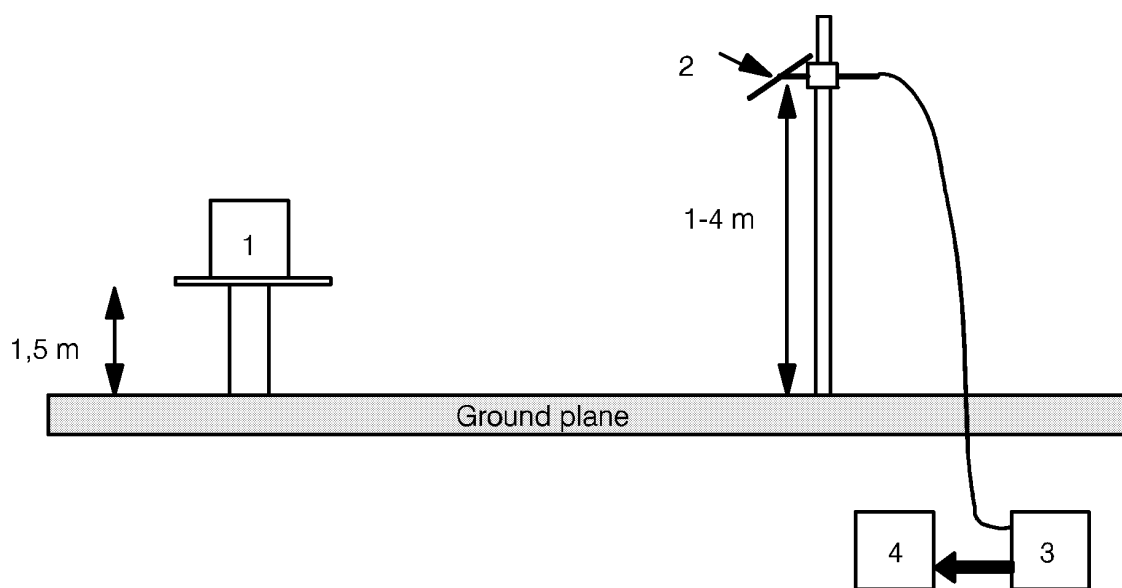

Figure A1

Legend

1. Equipment under test
2. Test antenna
3. High pass filter (necessary for strong fundamental Tx radiation)
4. Spectrum analyser or measuring receiver

A.1.2 Test antenna

The test antenna is used to detect the radiation from both the test sample and the substitution antenna, when the site is used for radiation measurements; where necessary, it is used as a transmitting antenna, when the site is used for the measurement of receiver characteristics.

This antenna is mounted on a support such as to allow the antenna to be used in either horizontal or vertical polarisation and for the height of its centre above ground to be varied over the range 1 to 4m. Preferably a test antenna with pronounced directivity should be used. The size of the test antenna along the measurement axis shall not exceed 20% of the measuring distance.

For receiver and transmitter radiation measurements, the test antenna is connected to a measuring receiver, capable of being tuned to any frequency under investigation and of measuring accurately the relative levels of signals at its input. For receiver radiated sensitivity measurements the test antenna is connected to a signal generator.

A.1.3 Substitution antenna

When measuring in the frequency range up to 1 GHz the substitution antenna shall be a $\lambda/2$ dipole, resonant at the frequency under consideration, or a shortened dipole, calibrated to the $\lambda/2$ dipole. The centre of this antenna shall coincide with the reference point of the test sample it has replaced. This reference point shall be the volume centre of the sample when its antenna is mounted inside the cabinet, or the point where an external antenna is connected to the cabinet.

The distance between the lower extremity of the dipole and the ground shall be at least 30 cm.

The substitution antenna shall be connected to a calibrated signal generator when the site is used for spurious radiation measurements and transmitter effective radiated power measurements. The substitution antenna shall be connected to a calibrated measuring receiver when the site is used for the measurement of receiver sensitivity.

The signal generator and the receiver shall be operating at the frequencies under investigation and shall be connected to the antenna through suitable matching and balancing networks.

A.1.4 Optional additional indoor site

When the frequency of the signals being measured is greater than 80 MHz, use may be made of an indoor site. If this alternative site is used, this shall be recorded in the test report.

The measurement site may be a laboratory room with a minimum area of 6m by 7m and at least 2.7m in height.

Apart from the measuring apparatus and the operator, the room shall be as free as possible from reflecting objects other than the walls, floor and ceiling.

The potential reflections from the wall behind the equipment under test are reduced by placing a barrier of absorbent material in front of it. The corner reflector around the test antenna is used to reduce the effect of reflections from the opposite wall and from the floor and ceiling in the case of horizontally polarised measurements. Similarly, the corner reflector reduces the effects of reflections from the side walls for vertically polarised measurements. For the lower part of the frequency range (below approximately 175 MHz)

no corner reflector or absorbent barrier is needed. For practical reasons, the $\lambda/2$ antenna in figure A.2 may be replaced by an antenna of constant length, provided that this length is between $\lambda/4$ and λ at the frequency of measurement and the sensitivity of the measuring system is sufficient. In the same way the distance of $\lambda/2$ to the apex may be varied.

The test antenna, measuring receiver, substitution antenna and calibrated signal generator are used in a way similar to that of the general method. To ensure that errors are not caused by the propagation path approaching the point at which phase cancellation between direct and the remaining reflected signals occurs, the substitution antenna shall be moved through a distance of $\pm 10\text{cm}$ in the direction of the test antenna as well as in the two directions perpendicular to this first direction. If these changes of distance cause a signal change of greater than 2 dB, the test sample should be re-sited until a change of less than 2 dB is obtained.

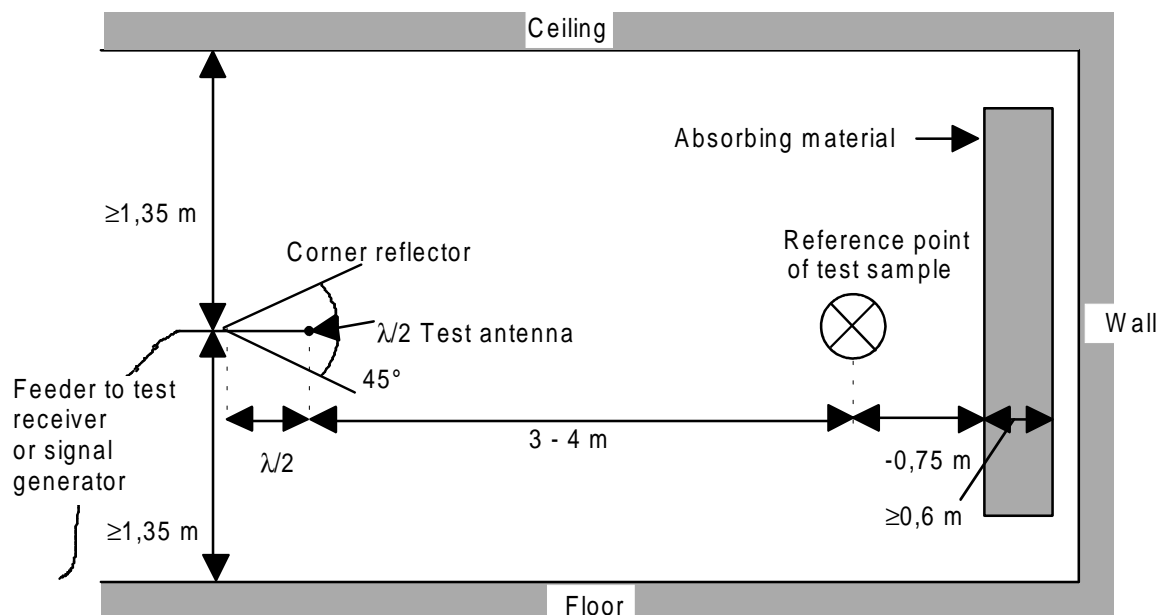

Figure A2: Indoor site arrangement (shown in horizontal polarisation)

A.2 Guidance on the use of radiation test sites

For measurements involving the use of radiated fields, use may be made of a test site in conformity with the requirements of subclause A.1 of this annex. When using such a test site, the following conditions should be observed to ensure consistency of measuring results.

A.2.1 Measuring distance

Evidence indicates that the measuring distance is not critical and does not significantly affect the measuring results, provided that the distance is not less than $\lambda/2$ at the frequency of measurement, and the precautions described in this annex are observed. Measuring distances of 3, 5, 10 and 30m are in common use in European test laboratories.

A.2.2 Test antenna

Different types of test antenna may be used, since performing substitution measurements reduces the effect of the errors on the measuring results.

Height variation of the test antenna over a range of 1 to 4m is essential in order to find the point at which the radiation is a maximum.

Height variation of the test antenna may not be necessary at the lower frequencies below about 100 MHz.

A.2.3 Substitution antenna

Variations in the measuring results may occur with the use of different types of substitution antenna at the lower frequencies below about 80 MHz. Where a shortened dipole antenna is used at these frequencies, details of the type of antenna used should be included with the results of the tests carried out on the site. Correction factors shall be taken into account when shortened dipole antennas are used.

A.2.4 Artificial antenna

The dimensions of the artificial antenna used during radiated measurements should be small in relation to the sample under test.

Where possible, a direct connection should be used between the artificial antenna and the test sample.

In cases where it is necessary to use a connecting cable, precautions should be taken to reduce the radiation from this cable by, for example, the use of ferrite cores or double screened cables.

A.2.5 Auxiliary cables

The position of auxiliary cables (power supply and microphone cables etc) which are not adequately decoupled may cause variations in the measuring results. In order to get reproducible results, cables and wires of auxiliaries should be arranged vertically downwards (through a hole in the non conducting support).

A.3 Further optional alternative indoor test site using an anechoic chamber

For radiation measurements when the frequency of the signals being measured is greater than 25 MHz, use may be made of an indoor site being a well-shielded anechoic chamber simulating free space environment. If such a chamber is used, this shall be recorded in the test report.

The test antenna, measuring receiver, substitution antenna and calibrated signal generator are used in a way similar to that of the general method, subclause A.1. In the range between 25 MHz and 100 MHz some additional calibration may be necessary.

An example of a typical measurement site may be an electrically shielded anechoic chamber being 10m long, 5m broad and 5m high. Walls and ceiling should be coated with RF absorbers of 1m height. The base should be covered with absorbing material 1m thick, and a wooden floor, able to carry test equipment and operators. A measuring distance of 3 to 5m in the long middle axis of the chamber can be used for measurements up to 12.75 GHz. The construction of the anechoic chamber is described in the following clauses.

A.3.1 Example of the construction of a shielded anechoic chamber

Free-field measurements can be simulated in a shielded measuring chamber where the walls are coated with RF absorbers. Figure A.3 shows the requirements for shielding loss and wall return loss of such a room. As dimensions and characteristics of usual absorber materials are critical below 100 MHz (height of absorbers < 1m, reflection attenuation < 20 dB) such a room is preferably suitable for measurements above 100 MHz. Figure A.4 shows the construction of a shielded measuring chamber having a base area of 5m by 10m and a height of 5m. Ceilings and walls are coated with pyramidal formed absorbers approximately 1m high. The base is covered with absorbers which are able to carry and which forms a sort of floor. The available internal dimensions of the room are 3m x 8m x 3m, so that a measuring distance of maximum 5m length in the middle axis of this room is available.

At 100 MHz the measuring distance can be extended up to a maximum of 2 lambdas. The floor absorbers reject floor reflections so that the antenna height need not be changed and floor reflection influences need not be considered. All measuring results can therefore be checked with simple calculations and the measuring tolerances have the smallest possible values due to the simple measuring configuration.

For special measurements it can be necessary to re-introduce floor reflections. Taking away the floor absorbers would mean a removal of approximately 24m³ absorber material. Therefore the floor absorbers are covered with metal plates of metallic nets instead.

A.3.2 Influence of parasitic reflections in anechoic chambers

For free-space propagation in the far field condition the correlation $E=E_0 (R_0/R)$ is valid for the dependence of the field strength E on the distance R , whereby E_0 is the reference field strength in the reference distance R_0 . It is useful to use just this correlation for comparison measurements, as all constants are eliminated with the ratio and neither cable attenuation nor antenna mismatch or antenna dimensions are of importance. Deviations from the ideal curve can be seen easily if the logarithm of the above equation is used, because the ideal correlation of field strength and distance can then be shown as a straight line and the deviations occurring in practice are clearly visible. This indirect method shows the disturbances due to reflections more readily and is far less problematical than the direct measurement of reflection attenuation.

With an anechoic chamber of the dimensions suggested in subclause A.3 at low frequencies up to 100 MHz there are no far field conditions, and therefore reflections are stronger so that careful calibration is necessary. In the medium frequency range from 100 MHz to 1 GHz the dependence of the field strength on the distance meets the expectations very well. In the frequency range of 1 to 12.75 GHz, because more reflections will occur, the dependence of the field strength on the distance will not correlate so closely.

A.3.3 Calibration of the shielded anechoic chamber

Careful calibration of the chamber shall be performed over the range 30 MHz to 12.75 GHz.

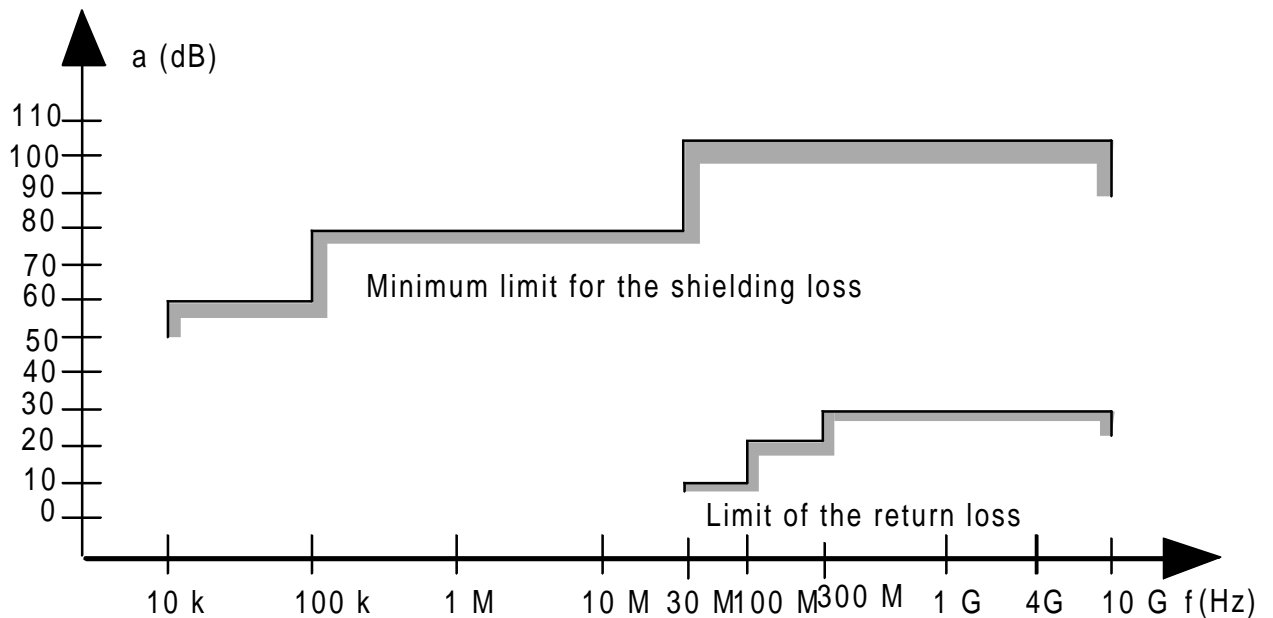

Figure A.3: Specifications for shielding and reflections

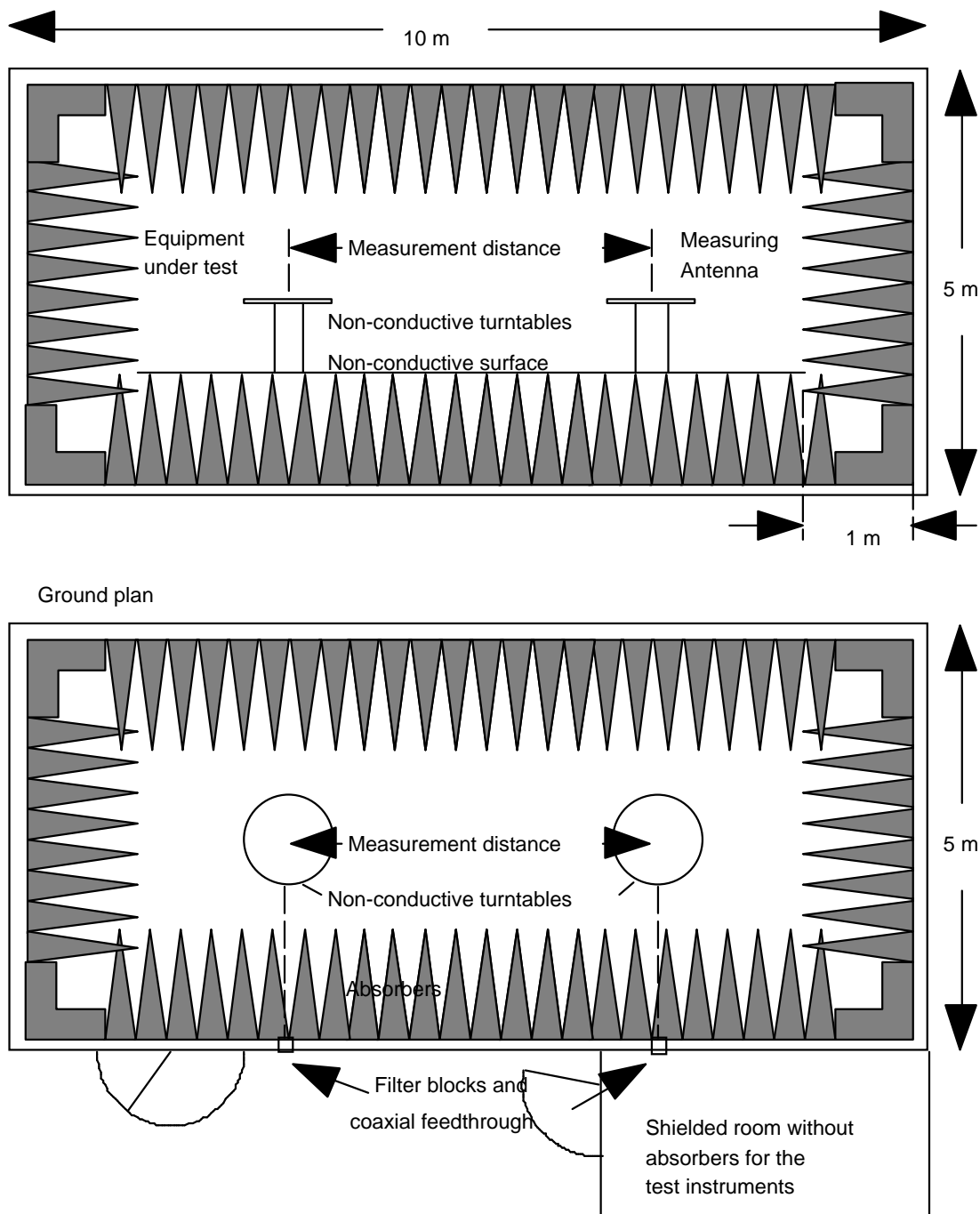

Figure A.4: Example of construction of an anechoic shielded chamber

Annex B: Specification for adjacent channel power measurement arrangements

B.1 Power measuring receiver specification

The power measuring receiver consists of a mixer, an IF filter, an oscillator, an amplifier, a variable attenuator and an rms value indicator. Instead of the variable attenuator with the rms value indicator it is also possible to use an rms voltmeter calibrated in dB as the rms value indicator. The technical characteristics of the power measuring receiver are given in subclauses B.1.1 to B.1.4.

B.1.1 IF filter

The IF filter shall be within the limits of the following selectivity characteristic.

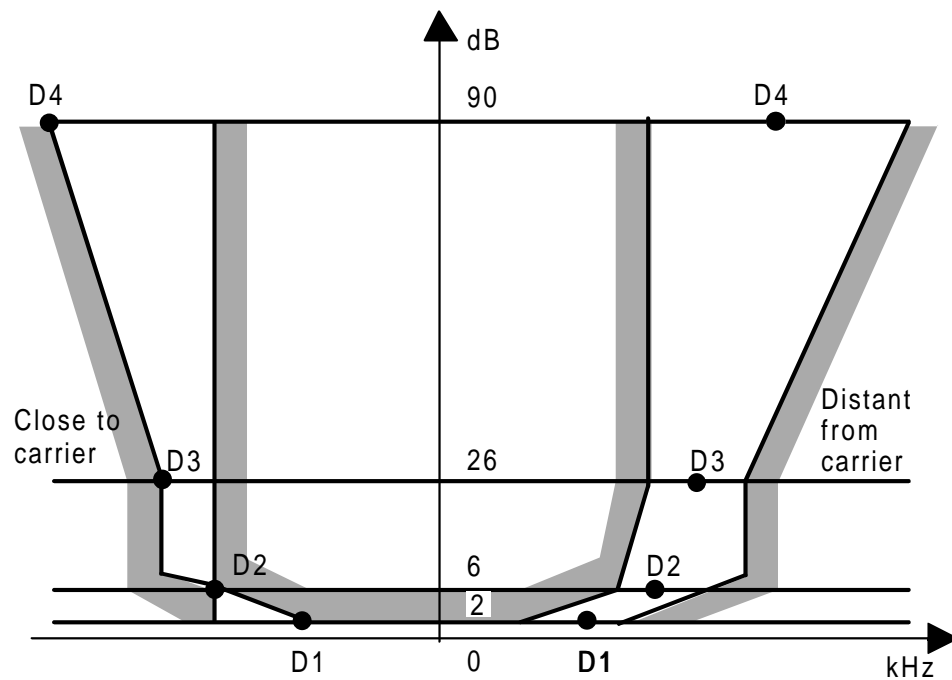

Figure B.1

The selectivity characteristic shall keep the frequency separations from the nominal centre frequency of the adjacent channel as mentioned in column 2 of table B1.

The attenuation points on the slope towards the carrier shall not exceed the tolerances, as mentioned in column 3 of table B1.

The attenuation points on the slope, distant from the carrier, shall not exceed the tolerances, as mentioned in column 4 of table B1.

Table 1: Selectivity characteristics of the "receiver"

1	2	3	4
Attenuation Points	Frequency Separations	Tolerance towards C	Tolerance distant from C
D1 (2dB)	3 kHz	+ 1.35 kHz	± 2 kHz
D2 (6dB)	4.25 kHz	± 0.1 kHz	± 2 kHz
D3 (26dB)	5.5 kHz	- 1.35 kHz	± 2 kHz
D4 (90dB)	9.5 kHz	- 5.35 kHz	+ 2 kHz and - 6 kHz

The minimum attenuation of the filter outside the 90 dB attenuation points must be equal to or greater than 90 dB.

B.1.2 Variable attenuator

The attenuation indicator shall have a minimum range of 80 dB and a reading accuracy of 1 dB.

B.1.3 Rms value indicator

The instrument shall accurately indicate non-sinusoidal signals in a ratio of up to 10:1 between peak value and rms value.

B.1.4 Oscillator and amplifier

The oscillator and the amplifier shall be designed in such a way that the measurement of the adjacent channel power of a low-noise unmodulated transmitter, whose self-noise has a negligible influence on the measurement result, yields a measured value of ≤ -80 dB referred to the carrier of the oscillator.

History

Document history	
June 1991	First Edition
February 1996	Converted into Adobe Acrobat Portable Document Format (PDF)