



EUROPEAN
TELECOMMUNICATION
STANDARD

ETS 300 133-4

July 1992

Source: ETSI TC-PS

Reference: DE/PS-2001-4

ICS: 33.080

Key words: ERMES, radio subsystem, air interface

**Paging Systems (PS);
European Radio Message System (ERMES);
Part 4 : Air interface specification**

ETSI

European Telecommunications Standards Institute

ETSI Secretariat

Postal address: F-06921 Sophia Antipolis CEDEX - FRANCE

Office address: 650 Route des Lucioles - Sophia Antipolis - Valbonne - FRANCE

X.400: c=fr, a=atlas, p=etsi, s=secretariat - **Internet:** secretariat@etsi.fr

Tel.: +33 92 94 42 00 - Fax: +33 93 65 47 16

Copyright Notification: No part may be reproduced except as authorized by written permission. The copyright and the foregoing restriction extend to reproduction in all media.

© European Telecommunications Standards Institute 1992. All rights reserved.

Contents

Foreword	5
1 Scope	7
2 Normative references	7
3 Definitions	7
4 Abbreviations	9
5 Transmission protocol	9
5.1 General description of the protocol	9
5.2 Outline of the air interface model	12
5.2.1 Information format L4	12
5.2.2 Error correction coding L3	12
5.2.3 Codeword interleaving L2	12
5.2.4 Modulation L1	12
5.3 Application of the model to the air interface	12
5.4 Batch structure	12
5.5 Subsequence lengths	13
6 Information format	14
6.1 General	14
6.2 Synchronisation partition	14
6.3 System information partition	14
6.3.1 System information	14
6.3.1.1 Format of the network information	14
6.3.1.2 Format of the time slot information	15
6.3.2 Supplementary system information	15
6.3.2.1 Supplementary system information field (SSIT=0000)	15
6.3.2.2 Supplementary system information field (SSIT=0001)	16
6.4 Address partition	16
6.5 Message partition	16
6.5.1 Message header	17
6.5.1.1 Variable information field (All=0)	17
6.5.1.2 Variable information field (All=1)	18
6.5.1.2.1 Long messages (All=1, AIT=001)	18
6.5.1.2.2 Remote programming of pager parameters (All=1, AIT=010)	18
6.5.1.2.3 Miscellaneous (All=1, AIT=100)	19
6.5.1.2.4 Common temporary address pointers (All=1, AIT=111)	20
6.5.2 Additional information and external operator identity	20
6.5.3 Message data	20
6.5.4 Message delimiter	21
6.5.5 Completion of message codeblocks	21
6.5.6 Unused codeblocks	21
7 Error correction coding	21
8 Codeword interleaving	23
9 Modulation	23
9.1 General	23
9.2 RF channels and channel numbering	23

9.3	Modulation format.....	23
9.3.1	Symbol alphabet.....	24
9.3.2	Data rate and symbol rate.....	24
9.3.3	Premodulation pulse shaping.....	24
9.3.4	Paging receiver performance.....	25
9.3.5	Transmitter performance.....	25
10	Operation of the radio subsystem	26
10.1	General	26
10.2	Frequency subset indicator and frequency subset number.....	26
10.3	Border area indicator	27
10.4	External traffic indicator.....	27
10.5	Examples of receiver operation.....	27
10.5.1	Non-locking receivers	27
10.5.2	Locking receiver	28
11	Paging message procedures on the air interface	28
11.1	General	28
11.2	Individual call procedure	28
11.3	Group call procedure	29
11.4	Handling of long messages.....	30
11.5	Messages continued in further batches in the same subsequence.....	31
11.6	Messages continued in further subsequences	31
11.7	Transmission of variable receiver parameters	31
11.8	Termination of message search	31
11.8.1	Individual calls	31
11.8.2	Group calls.....	31
12	Battery saving techniques.....	32
12.1	Batch level	32
12.2	Subsequence level.....	32
12.3	Cycle level	32
12.4	Sequence level	32
13	Synchronisation	33
13.1	General	33
13.2	Synchronisation between paging receiver and radio transmission.....	33
13.3	Synchronisation between base stations	33
13.4	Co-ordination between networks.....	34
Annex A (normative):	List of country or area numbers.....	35
History.....		39

Foreword

This European Telecommunication Standard (ETS) has been produced by the Paging Systems (PS) Technical Committee of the European Telecommunications Standards Institute (ETSI).

This ETS comprises seven parts with the generic title "Paging systems; European Radio Message System (ERMES)". The title of each part is listed below:

- ETS 300 133-1: "Part 1 - General aspects"
- ETS 300 133-2: "Part 2 - Service aspects"
- ETS 300 133-3: "Part 3 - Network aspects"
- ETS 300 133-4: "Part 4 - Air interface specification"
- ETS 300 133-5: "Part 5 - Receiver conformance specification"
- ETS 300 133-6: "Part 6 - Base station specification"
- ETS 300 133-7: "Part 7 - Operation and maintenance aspects"

This part, ETS 300 133-4, specifies the radio subsystem aspects including:

- the transmission protocol and its operation;
- modulation characteristics;
- channel coding;
- quasi-synchronous operation;
- receiver battery saving techniques.

NOTE: In this part of the ERMES ETS, some protocol bits have been "reserved for future definition". It is intended that these bits will be allocated for specific options in a future enhanced version of the standard.
Suggestions for potential enhancements to the protocol using these bits should be communicated via the normal ETS maintenance procedures to the ETSI Secretariat at the address given on the title page.

Blank page

1 Scope

This part of the seven part European Telecommunication Standard (ETS) 300 133 describes the radio air interface specification of the European Radio Message System (ERMES). All aspects of the radio subsystem are defined including the transmission protocol, information format, channel coding and modulation characteristics. Operation of the radio subsystem and procedures on the air interface are defined and described.

2 Normative references

This ETS incorporates by dated or undated reference, provisions from other publications. These normative references are cited at the appropriate places in the text and the publications are listed hereafter. For dated references subsequent amendments to, or revisions of any of these publications apply to this ETS only when incorporated in it by amendment or revision. For undated references the latest edition of the publication referred to applies.

- [1] ETS 300 133-2 (1992): "Paging Systems (PS); European Radio Message System (ERMES) Part 2: Service aspects".
- [2] ETS 300 133-5: (1992) "Paging Systems (PS); European Radio Message System (ERMES) Part 5: Receiver conformance specification".
- [3] ETS 300 133-6: (1992) "Paging Systems (PS); European Radio Message System (ERMES) Part 6: Base station conformance specification".
- [4] CCITT Recommendation E.212 (1988): "Identification plan for land mobile stations", Annex A.
- [5] CEPT Recommendation T/R 25-07, Annex 1: "Frequency coordination for the European radio message system (ERMES)".

3 Definitions

For the purposes of this part of ETS 300 133 the following definitions shall apply.

Associated Operator: one of the network operators with which the home operator has an agreement to exclusively transfer calls.

Basic RIC: the prime identity of a paging receiver allocated by the network operator when service is initiated. It shall not be changed without safeguards against unauthorised changes.

Batch number: the 4 bit number corresponding to a particular batch type. Batch type A shall correspond to batch number 0000. Batch type P shall correspond to batch number 1111.

Batch type: the letter (A to P) which identifies one of the 16 batches within a subsequence.

Codeblock: Nine codewords interleaved as a unit as used in the message partition.

Codeword: the standard information unit of 30 bits length.

Country code: binary representation of the country number defined in Annex A. The country code consists of 7 bits. (See also subclause 6.3.1.1).

End of Message (EOM) character: a specific character used to indicate the end of an alphanumeric message. It corresponds to DC1 as defined in Annex C2 of ETS 300 133-5 [2].

External Receiver: a receiver operating in a network which is not its home network.

Frequency divided network: a network that uses different frequency channels in adjacent paging areas.

Geographical Area: one or several paging areas in an operator network. Defined by agreements between network operators for internetwork roaming or by a single operator for roaming within his own network. It is used for roaming and choice of destination supplementary services.

Home Network: the operator network with which a mobile subscriber has signed a subscription.

Home Operator: the network operator to which a specific user has subscribed.

Initial Address: the 18 most significant bits of the local address.

I1 interface: the radio interface between the base stations and the paging receivers.

I2 interface: an interface between the Paging Area Controller and the Base Station.

Local Address: the number used by a network to identify the receivers subscribed to it. It consists of 22 bits. The four least significant bits of the local address denote the batch number of the receiver.

Long Message: a message that has been split into two or more parts (sub-messages) for transmission.

Operator code: the number used by the system on the radio path to identify an operator within a country. It consists of 3 bits.

Operator Identity: the number used by the system on the radio path to identify the home operator of a receiver. It has a total length of 13 bits and consists of three parts, the zone code, the country code and the operator code.

Paging Area: the area controlled by a PAC. It is the minimum area to which a mobile subscriber is permitted to subscribe in order to receive his paging messages.

Paging Area Code: the number used by the system to identify the paging area.

Paging Area Controller: functional entity controlling the base stations within one paging area.

Paging Message: the tone-only, numeric, alpha-numeric or transparent data information sent to a paging receiver.

Paging Signal: the signal sent on the radio path to a paging receiver.

Radio Identity Code: the number used by the system on the radio path to identify the receiver(s) for which the paging message is intended. The RIC has a total length of 35 bits and consists of five parts: the zone code (3 bits), the country code (7 bits), the operator code (3 bits), the initial address (18 bits) and the batch number (4 bits).

Operator Identity			Local Address		
Zone code	Country code	Operator Code	Initial address	Batch number	
No. of bits	3	7	3	18	4

No. of bits 3 7 3 18 4

Reserved for future definition: the bits indicated are not specified in this edition of the standard but may be in future editions. The bits should be set to a default value of zero and not used to convey information. The function of any equipment shall be independent of these bits. No fixed pattern of reserved bits should be assumed and no combination of reserved bits shall cause equipment to malfunction.

Roaming Area: the geographical area where the mobile subscriber asks for his messages to be transmitted when he uses the roaming service.

Service Area: the paging area(s) to which the mobile subscriber has subscribed and in which a paging message will normally be transmitted.

Sub-message: part of a long message. All sub-messages of any one long message carry the same message number.

Symbol: two bits of information which are the basic unit of information on the air interface. It corresponds to one of the four modulation levels specified in subclause 9.3.1.

Time divided network: a network that uses the same frequency channel during different sub-sequences (periods of a time cycle) in adjacent paging areas.

Zone code: binary representation of the zone number defined in Annex A. The zone code consists of 3 bits (see also subclause 6.3.1.1).

4 Abbreviations

AII	Additional Information Indicator
AIF	Additional Information Field
AIN	Additional Information Number
AIT	Additional Information Type
BAI	Border Area Indicator
BS	Base Station
CTA	Common Temporary Address
CTAP	Common Temporary Address Pointer
EB	External Bit
ENL	Number of LSBs to be compared when operating outside home network
ETI	External Traffic Indicator
FSI	Frequency Subset Indicator
FSN	Frequency Subset Number
HNL	Number of LSBs to be compared when operating within home network
LSB	Least Significant Bit
MSB	Most Significant Bit
OPID	Operator Identity
PA	Paging Area
PR	Preamble
PAC	Paging Area Controller
RF	Radio Frequency
RIC	Radio Identity Code
RSVD	Reserved bits for future definition
SM	Subsequence mask
SSIF	Supplementary System Information Field
SSIT	Supplementary System Information Type
SSN	Subsequence Number
UMI	Urgent Message Indicator
UTC	Universal Time Co-ordinated
VIF	Variable Information Field

5 Transmission protocol

5.1 General description of the protocol

The structure of the basic transmission protocol on channel one is illustrated in figure 1.

A sequence of 60 minutes total duration and comprising 60 cycles shall be provided. Sequences shall be co-ordinated with the UTC so that on the hour a new sequence commences.

A paging cycle of exactly one minute duration, co-ordinated with UTC, shall be used to allow the necessary co-ordination between different networks. Receivers may listen to one or a few cycles in a sequence in order to reduce battery consumption (see Clause 12).

Each cycle shall be divided into five subsequences commencing at 12 second intervals. To allow co-ordination between networks the SSN=0 subsequence shall always be transmitted first after the UTC minute marker.

The transmission of a subsequence may end before the full 12 seconds has elapsed. The subsequence length may be reduced by a small amount to allow for transmitter switching times. Occasionally a greater reduction may be made in order that test or system transmissions can be made by individual transmitters.

Each subsequence shall be further divided into 16 batches labelled A-P. The receiver population should be divided into 16 groups and each receiver allocated to one of the 16 batch types according to the 4 least significant bits of its basic RIC. Further RICs used by this receiver shall be of the same batch type.

Each receiver shall only be initially addressed in its own batch type transmission. When the receiver detects its initial address it should wait on the same channel for the message to be sent. The message may be sent in the same batch, in any subsequent batch of the same subsequence or in the following subsequence (see subclause 11.6 regarding time-out conditions).

An initial address may be transmitted more than once in the same batch (see subclause 11.2).

The time of transmission of a particular batch type on each frequency channel is shifted by a single time batch with respect to the others as shown in figure 2. Consequently a receiver can, if necessary, step through the paging frequency channels without losing any messages.

The first fifteen batches in every subsequence shall have length 154 codewords. The final batch in every subsequence shall have length 190 codewords. This is so that messages in time divided networks may be completed within a subsequence.

Each batch is further subdivided into four partitions. These are the synchronisation, system information, address and message partitions. A detailed description of the batch structure is given in subclause 5.4 and the contents of each partition specified in subclauses 6.2 to 6.5.

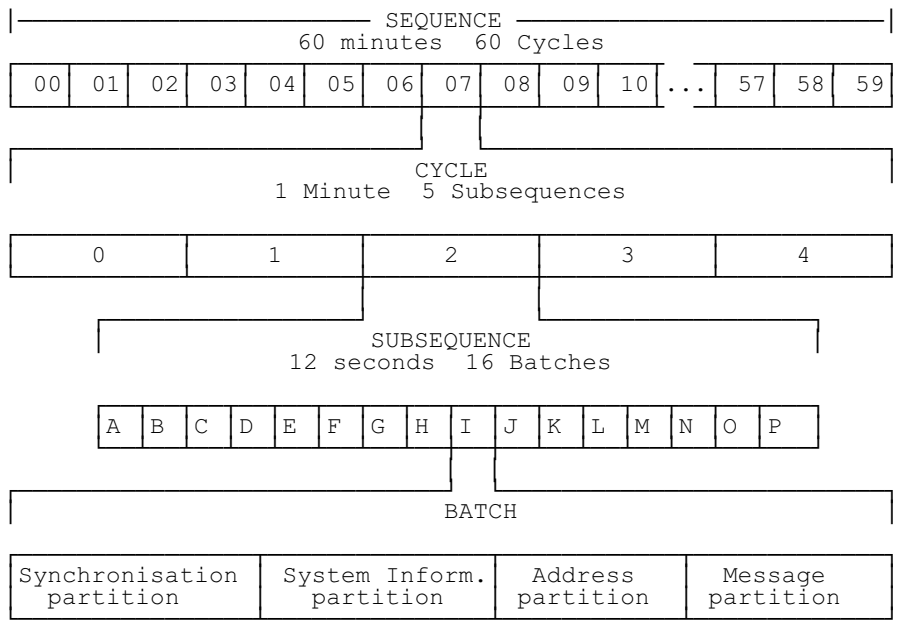

Figure 1: Structure of the radio protocol on channel one.

■ = Active batch for a batch type A receiver.

CHAN	<----- 12 secs ----->																											
01	■	B	C	D	E	F	G	H	I	J	K	L	M	N	O	P	■	B	C	D	E	F	G	H	I	J	K	L
03	P	■	B	C	D	E	F	G	H	I	J	K	L	M	N	O	P	■	B	C	D	E	F	G	H	I	J	K
05	O	P	■	B	C	D	E	F	G	H	I	J	K	L	M	N	O	P	■	B	C	D	E	F	G	H	I	J
07	N	O	P	■	B	C	D	E	F	G	H	I	J	K	L	M	N	O	P	■	B	C	D	E	F	G	H	I
09	M	N	O	P	■	B	C	D	E	F	G	H	I	J	K	L	M	N	O	P	■	B	C	D	E	F	G	H
11	L	M	N	O	P	■	B	C	D	E	F	G	H	I	J	K	L	M	N	O	P	■	B	C	D	E	F	G
13	K	L	M	N	O	P	■	B	C	D	E	F	G	H	I	J	K	L	M	N	O	P	■	B	C	D	E	F
15	J	K	L	M	N	O	P	■	B	C	D	E	F	G	H	I	J	K	L	M	N	O	P	■	B	C	D	E
16	I	J	K	L	M	N	O	P	■	B	C	D	E	F	G	H	I	J	K	L	M	N	O	P	■	B	C	D
14	H	I	J	K	L	M	N	O	P	■	B	C	D	E	F	G	H	I	J	K	L	M	N	O	P	■	B	C
12	G	H	I	J	K	L	M	N	O	P	■	B	C	D	E	F	G	H	I	J	K	L	M	N	O	P	■	B
10	F	G	H	I	J	K	L	M	N	O	P	■	B	C	D	E	F	G	H	I	J	K	L	M	N	O	P	■
08	E	F	G	H	I	J	K	L	M	N	O	P	■	B	C	D	E	F	G	H	I	J	K	L	M	N	O	P
06	D	E	F	G	H	I	J	K	L	M	N	O	P	■	B	C	D	E	F	G	H	I	J	K	L	M	N	O
04	C	D	E	F	G	H	I	J	K	L	M	N	O	P	■	B	C	D	E	F	G	H	I	J	K	L	M	N
02	B	C	D	E	F	G	H	I	J	K	L	M	N	O	P	■	B	C	D	E	F	G	H	I	J	K	L	M

Figure 2: Channel synchronisation and the scanning procedure

NOTE: The relation between RF channel frequencies and channel numbers is defined in subclause 9.2.

5.2 Outline of the air interface model

The air interface transmissions are organised in four levels:

L4 - information format;

L3 - error correction coding;

L2 - codeword interleaving;

L1 - modulation.

5.2.1 Information format L4

Co-ordination of the basic paging system data and paging message data is performed at the format information level. It is a way of arranging the transmitted data in a predefined format that will be recognised by the receivers.

Throughout this standard the bit transmission order shall be from left to right. Accordingly the Most Significant Bit (MSB), which is the left most bit, will be transmitted first. The Least Significant Bit (LSB) is the right most bit and will be transmitted last.

5.2.2 Error correction coding L3

Forward error correction coding adds redundancy to the transmitted codewords so that after demodulation and de-interleaving transmission errors may be detected and corrected.

5.2.3 Codeword interleaving L2

Interleaving is the technique to spread burst errors that occur on radio channels subject to multipath/fading and impulsive noise. This is achieved by changing the order of bits in the transmitted data stream so that on reception any burst of errors that has occurred is spread over several codewords and there is a chance that some or all of them may be corrected. This is further described in Clause 8.

5.2.4 Modulation L1

The function of the modulation level is to distribute by radio transmission the coded and formatted information from the base station transmitters to the paging receivers.

5.3 Application of the model to the air interface

Each of the processing levels will be described in detail in the following clauses. Not all levels shall be applied to all parts of the interface transmissions. This is best specified at the batch level (see figure 1) where the following shall apply:

- synchronisation partition; L1 & L4;
- system information partition; L1, L3 & L4;
- address partition; L1, L3 and L4;
- message partition; L1, L2, L3 and L4.

5.4 Batch structure

The synchronisation partition and system information partition are of fixed length. The boundary between the address and message partitions can be altered depending on traffic type and density. The requirement for codeword interleaving in the message partition imposes detailed constraints on the position of the boundary. As shown in Clause 8 the protocol specifies codeword interleaving to a depth of nine codewords. Hence messages shall be assembled and transmitted in blocks of 9 codewords (which are

called codeblocks) and the address partition/message partition boundary positioned to allow this. Unused codewords within an address partition shall be filled with Address Partition Terminators (APTs) as defined in subclause 6.4. Unused codewords within an interleaved message codeblock shall be filled with message delimiters as defined in subclause 6.5.4. Unused bits within a message codeword shall be filled as described in subclause 6.5.3. The detailed composition of a batch is as follows:

PR	SYN	SI	SI	SSI	I*IA	J*APT	K*CODEBLOCKS
SYNCH PART		SYSTEM INF PARTITION			ADDRESS PARTITION		MESSAGE PARTITION

- | | | |
|-----------|---|----------------------------|
| PR | - preamble word | defined in subclause 6.2 |
| SYN | - synchronisation word | defined in subclause 6.2 |
| SI | - system information | defined in subclause 6.3.1 |
| SSI | - supplementary system information | defined in subclause 6.3.2 |
| IA | - initial address | defined in Clause 3 |
| APT | - address partition terminator | defined in subclause 6.4 |
| CODEBLOCK | - interleaved messages | defined in subclause 6.5 |
| I | - number of initial addresses
$0 \leq I \leq 139$ | |
| J | - number of address partition terminators
$J = 9 - \text{MOD}\{(4+I),9\}$ where $\text{MOD}\{M,N\} = M - N \cdot \text{INT}(M/N)$ and INT returns the integer part of a number | |
| K | - number of codeblocks in the message partition
$K \leq (149 - I - J)/9$ first 15 batches of a subsequence
$K \leq (185 - I - J)/9$ last batch of a subsequence | |

Typical values of parameters for the first 15 batches are:

Typical values of parameters for the last batch are:

I=0 J=5 K=16 ì maximum No.
I=4 J=1 K=16 ì of messages
I=5 J=9 K=15
I=139 J=1 K=1 - max. No. of
initial addresses

I=0 J=5 K=20 ì maximum No.
I=4 J=1 K=20 ì of messages
I=22 J=1 K=18
I=139 J=1 K=5 - max. No. of
initial addresses

5.5 Subsequence lengths

The length of a subsequence shall be 12 seconds (2500 codewords).

The duration of data transmission within the subsequence may, however, be less than this. In the case that less than 2500 codewords are transmitted the number of transmitted codewords shall be 2500 minus an integer multiple of 9 codewords.

The minimum number of codewords that may be transmitted in a subsequence is zero, notwithstanding the requirements of subclauses 10.1 and 6.4.

The minimum reduction in subsequence transmission length that may be made is 1 codeblock (9 codewords (43,2ms)).

6 Information format

6.1 General

Each batch consists of four partitions as illustrated in subclause 5.4. Details of how the paging data is organised within each partition are defined in this Clause.

6.2 Synchronisation partition

Each batch shall commence with the synchronisation partition which consists of two 30 bit words, which are the preamble and the Synchronisation Word (SW).

The preamble may be used to obtain bit synchronisation.

The preamble word shall be 00 10 00 10 00 10 00 10 00 10 00 10 00 10 00 (30 bits).

The synchronisation word may be used to obtain code word synchronisation.

The synchronisation word SW1 shall be 10 00 10 10 00 10 00 00 10 10 00 00 10 10 10 (30 bits).

Alternative synchronisation words may be used in future versions of the protocol.

6.3 System information partition

Network operator and system operational information is transmitted in the system information partition. The system information partition is divided into two consecutive parts - system information and supplementary system information with the system information transmitted first.

6.3.1 System information

The system information part shall comprise the following:

No. of bits	Country code	Operator code	PA code	ETI	BAI	FSI	Cycle No.	SSN	Batch No.
	7	3	6	1	1	5	6	3	4

Country Code - of the transmitting network.	
Operator Code - code of the network operator.	(see subclause 6.3.1.1)
PA code - paging area code.	
Cycle No. -	
SSN - subsequence number	(see subclause 6.3.1.2)
Batch No. -	

ETI - External traffic indicator. (see subclause 10.4)
0 External traffic will not be initially addressed in this batch.
1 External traffic will be initially addressed in this batch.

BAI - Border area indicator. |
0 Indicates non border area. | (see subclause 10.3)
1 Indicates border area. |

FSI - Frequency subset indicator. (see subclause 10.2)

6.3.1.1 Format of the network information

Zone and country numbers are based on CCITT Recommendation E.212 [4], Annex A. They are defined for the purposes of the present standard in Annex A of this ETS. A unique number consisting of 3 digits shall be allocated to each country or area. The first digit denotes the zone to which the country belongs. The last two digits indicate the country itself.

The first digit (zone number) shall be coded with 3 binary bits and sent as supplementary system information at least once per hour to every pager (see also Clause 12). These bits represent the zone code. The last two digits shall be coded with 7 binary bits. These bits represent the country code.

Three bits are used to define up to 8 different operators within each country. (Additional codes may be provided by the use of country codes that are not currently allocated to any country).
Six bits are used to define one of up to 64 paging areas within a paging network.

6.3.1.2 Format of the time slot information

Each batch type transmission shall be identified on the radio channel by a four bit binary number. The number shall correspond to a simple alphabet to binary number translation. Thus batch type A corresponds to batch number 0000, batch type P to batch number 1111.

A three bit binary representation of the decimal numbers 0,1,2,3,4 shall be used to identify the subsequence numbers.

A six bit binary number shall be used to identify the cycle numbers 0, 1, 2 to 59, with the corresponding binary representations being 000000, 000001, 000010, to 111011 .

6.3.2 Supplementary system information

The supplementary system information part shall take the following form:

	SSIT	SSIF
No. of bits	4	14

SSIT - supplementary system information type.
 0000 zone/hour/date.
 0001 day/month/year.
 All other values of SSIT shall be reserved for future definition

SSIF - supplementary system information field.

6.3.2.1 Supplementary system information field (SSIT=0000)

The supplementary system information field shall take the following form:

	Zone	Hour	Date	RSVD
No. of bits	3	5	5	1

Zone - zone number (see subclause 6.3.1.1).
 Hour - Local hour.
 Hours shall be numbered from zero (00000) to 23 (10111).
 Date - Local date.
 Day of the month shall be numbered from one (00001) to 31 (11111).
 RSVD - Reserved for future definition (see Clause 3)

6.3.2.2 Supplementary system information field (SSIT=0001)

The supplementary system information field shall take the following form:

	Day	Month	Year
No. of bits	3	4	7

- Day - Local day of week.
Days shall be numbered 1 to 7. Day 1 (001) shall be Monday.
- Month - Months shall be numbered 1 to 12.
Month 1 (0001) shall be January.
- Year - Year zero (0000000) shall be 1990.

6.4 Address partition

An address partition shall be provided in each of the batches A-P in a subsequence.

The address partition of a particular batch shall contain the initial addresses of the receivers to be accessed and which belong to that particular batch type. See subclause 11.6 for a definition of the time-out periods.

The address partition shall be of variable length up to a maximum of 140 codewords. It shall comprise an integral number of initial addresses. The minimum content of the address partition shall be no addresses and five Address Partition Terminators (APTs).

The addresses in a particular batch shall be arranged so that the highest initial address is sent first and others sent in descending order.

The address partition shall be terminated with an Address Partition Terminator (APT). This terminator shall be sent even if there are no addresses in the address partition. APTs may also be used as filler codewords as described in subclause 5.4.

The address partition terminator shall be 10 01 00 11 10 00 01 10 00 10 00 11 10 01 00

6.5 Message partition

The message partition shall consist of messages separated by message delimiters. Each message partition shall comprise an integer number of codeblocks as described in subclause 5.4.

Each message shall consist of a fixed length message header (36 bits) which may be followed by the external operator identity, an additional information field and the message data.

6.5.1 Message header

The fixed length message header shall take the following form:

	Local Address	Message Number	External bit	AII	VIF
No. of bits	22	5	1	1	7

- Local Address - full local address of the called receiver.
- Message Number - number of message to a particular receiver.
For an individual call the initial value shall be 00001.
For group calls the reserved dummy value 00000 shall be used.
- External Bit - indicates if a local or an external receiver is addressed.
0 addressed receiver is in its home network.
1 external receiver is addressed.
- AII - Additional Information Indicator
0 additional information will not be sent.
1 additional information will be sent.
- VIF - Variable Information Field.

6.5.1.1 Variable information field (All=0)

The VIF shall take the following form:

	RSVD	Paging Category	UMI	ALERT
No. of bits	1	2	1	3

- RSVD - Reserved for future definition (see Clause 3).
- Paging Category - of the transmitted message.
00 tone
01 numeric
10 alphanumeric
11 transparent data
- UMI - Urgent Message Indicator.
0 normal message
1 urgent message
- ALERT - Alert signal indicator for different types of alert.
000 type 0
001 type 1
010 type 2
011 type 3
100 type 4
101 type 5
110 type 6
111 type 7

6.5.1.2 Variable information field (All=1)

The VIF shall take the following form:

	AIT	AIN
No. of bits	3	4

- AIT - Additional information type.
- 001 Long message
 - 010 Remote programming of pager parameters
 - 100 Miscellaneous
 - 111 Common Temporary Address Pointers (CTAPs)

All other combinations of AIT bits shall be reserved in order to give security to the currently allocated AITs.

- AIN - Additional information number.
(Defined in the following subclauses)

6.5.1.2.1 Long messages (All=1, AIT=001)

AIN	FUNCTION	
0000	non-urgent alert type	0
0001	"	1
0010	"	2
0011	"	3
0100	"	4
0101	"	5
0110	"	6
0111	"	7
1000	urgent alert type	0
1001	"	1
1010	"	2
1011	"	3
1100	"	4
1101	"	5
1110	"	6
1111	"	7

The Additional Information Field (AIF) associated with this AIT (see subclause 6.5.2) shall comprise 2 bits for paging category (defined in subclause 6.5.1.1) followed by 16 bits specifying the message length.

6.5.1.2.2 Remote programming of pager parameters (All=1, AIT=010)

AIN	Function
0001	Radio identity code
0010	Paging Area
0100	Associated paging operator
1000	Subsequence set in subsequence home network (see NOTE)
0111	Subsequence set in subsequence outside home network
1011	For future definition
1101	For future definition
1110	For future definition

All other combinations of AIN bits shall be reserved in order to give security to the currently allocated AINs.

NOTE: A subsequence set is that set of cycles and subsequences during which transmissions are scheduled for a particular receiver.

The Additional Information Fields (AIF) associated with this AIT (see subclause 6.5.2) shall comprise the following:

Two functional bits are used at the start of the AIFs. Their interpretation shall be as follows:

- F = 00 = Add to data stored in pager
- F = 01 = Remove from data stored in pager
- F = 10 = Remove all additional data stored in pager
- F = 11 = Reserved for future definition

AIN	AIF
0001	F + RIC. (2 + 31 bits) (Zone + Country + Operator + Initial address) No. of bits 3 7 3 18
0010	F + Paging area information (2 + 19 bits) (Zone + Country + Operator + Paging Area) No. of bits 3 7 3 6
0100	F + Associated operator information (2 + 13 bits) (Zone + Country + Operator) No. of bits 3 7 3
1000	F + Subsequence set in subsequence home network 3 bit value of HNL to identify active cycles (see subclause 12.4) 5 bit mask SM to identify active subsequence (see subclause 12.3) (SM + HNL) No. of bits 5 3
0111	F + Subsequence set in subsequence outside home network 3 bit value of ENL to identify active cycles (see subclause 12.4) 5 bit mask SM to identify active subsequence (see subclause 12.3) (SM + ENL) No. of bits 5 3

6.5.1.2.3 Miscellaneous (All=1, AIT=100)

AIN	Function.
0001	Retransmission of latest message number (AIF has zero length) The most recent message number (contained in the message header) is sent to the addressed receiver. (See ETS 300 133-2 [1] subclause 5.3.1.3.3).
0010	Character set for associated message Identifies one of up to 32 additional character sets for associated message. AIF has 5 bits. Contents of additional character sets are for future definition.

All other values of AIN are for future definition.

6.5.1.2.4 Common temporary address pointers (All=1, AIT=111)

AIN	CTAP	CTA
0000	0	111111111111111111 0000
0001	1	111111111111111111 0001
0010	2	111111111111111111 0010
0011	3	111111111111111111 0011
. . . .	etc. up to	
1110	14	111111111111111111 1110
1111	15	111111111111111111 1111

The function of Common Temporary Address Pointers (CTAP) and the relationship between address pointers and addresses is described in subclause 11.3. The AIF associated with this AIT has zero length.

6.5.2 Additional information and external operator identity

When the All bit is set to one, additional information will be sent in or after the message header.

The additional information will be contained in an additional information field (AIF) of variable length. The length of the AIF may be zero (as in the case of All=1, AIT=111).

When EB=1 the AIF (if any) will be preceded by the operator identity OPID of the receiver's home operator (13 bits).

Trailing binary zeros shall be added to the OPID or AIF in order to complete a codeword (18 information bits).

6.5.3 Message data

Message characters (7 bit alphanumeric, 4 bit numeric or transparent data) shall be placed continuously in the 18 bit information fields of message codewords. The MSB of the first message character to be displayed shall be placed in the MSB of the first codeword following the message header. Message characters are defined in ETS 300 133-2 [1], Annex B.

After the last character (or bit) of the message the following message termination procedures shall be used:

- alphanumeric:** an EOM character (0010001) shall be appended;
- numeric:** no terminating character required;
- transparent data:** a single bit set to one shall be appended.

As messages can be of any length up to the maximum specified in subclause 11.4, most will not fit exactly into the 18 information bit codeword structure dictated by the error correction code. Unused bits in message codewords shall be set to the following default values:

- alphanumeric -** EOM characters and partial EOM characters (MSB used first) shall be repeated to fill the remaining bits;
- numeric -** space character and partial space characters (MSB used first) shall be repeated to fill the remaining bits;
- transparent data -** binary zeros shall be used to fill the remaining bits.
| XXXXXXX:1:000000000 | Message delimiter |
where XXXXXXX = Transparent data

Codeblocks consisting entirely of message delimiters may be transmitted in order to complete a batch.

6.5.4 Message delimiter

Every message shall be preceded and terminated by a message delimiter. A single message delimiter shall separate different messages.

The message delimiter shall be aligned with the codeword boundary and take the form:

11 01 01 01 11 10 01 11 11 10 11 10 11 10 11

6.5.5 Completion of message codeblocks

Since message partition data will not in general fill a codeblock (as required for interleaving) unused codewords after the last message delimiter shall be filled with further message delimiters. If continuous signal transmission is not required, the transmitter may be turned off after the last completed codeblock.

6.5.6 Unused codeblocks

During periods of transmission after the last message has been sent, interleaved codeblocks consisting entirely of message delimiters should be transmitted by those operators who choose not to switch off their transmitters.

7 Error correction coding

The shortened cyclic (30,18) code shall be used. Each codeword shall consist of 18 information bits and 12 check bits. The generator polynomial for the code shall be:

$$g(x) = x^{12} + x^{11} + x^9 + x^7 + x^6 + x^3 + x^2 + 1 = 15315_8$$

This generator polynomial is derived from the generator polynomial of the BCH(31,21) code, $g(x)_{31,21} = 3551_8$. The relation between these polynomials is given by:

$$g(x) = g(x)_{31,21}(x+1)(x+1)$$

The Hamming distance for the (30,18) code is 6. For hard decision decoding any two errors may be corrected whilst any three errors may be detected.

The twelve bit checkword shall be formed by taking the remainder after multiplication of the 18 information bits by x^{12} and then division (modulo-two) by the generator polynomial $g(x)$ of the message word.

Thus if the polynomial:

$$m(x) = m_{17}x^{17} + m_{16}x^{16} + \dots + m_1x + m_0$$

where the coefficients m_n having value 0 or 1 represent the 18 bit message word, then the 30 bit codeword is given by:

$$c(x) = m(x)x^{12} + m(x)x^{12} \text{ mod } g(x)$$

The codeword shall be transmitted MSB first - that is to say information bits c_{29} to c_{12} , followed by check bits c_{11} to c_0 .

The encoding process may alternatively be considered in terms of its generator matrix G which is derived from the generator matrix (last row).

$$G = \left[\begin{array}{c|c} 100000000000000000 & 111100001000 \\ 010000000000000000 & 011110000100 \\ 001000000000000000 & 001111000010 \\ 000100000000000000 & 000111100001 \\ 000010000000000000 & 110110010110 \\ 000001000000000000 & 011011001011 \\ 000000100000000000 & 111000000011 \\ 000000010000000000 & 101001100111 \\ 000000001000000000 & 100001010101 \\ 000000000100000000 & 100101001100 \\ 000000000010000000 & 010010100110 \\ 000000000001000000 & 001001010011 \\ 000000000000100000 & 110001001111 \\ 000000000000010000 & 101101000001 \\ 000000000000001000 & 100011000110 \\ 000000000000000100 & 010001100011 \\ 000000000000000010 & 111101010111 \\ 000000000000000001 & 101011001101 \end{array} \right]$$

The check bits of the codeword are readily generated by the modulo-two addition of all the rows of the generator matrix for which the corresponding coefficient in the message word is "1". Thus for the message word:

$$m(x) = 000\ 000\ 000\ 000\ 000\ 001$$

The corresponding codeword is:

$$c(x) = 000\ 000\ 000\ 000\ 000\ 001\ 101\ 011\ 001\ 101 = g(x)$$

Similarly for the all "1"s message word:

$$m(x) = 111\ 111\ 111\ 111\ 111\ 111$$

The corresponding codeword is:

$$c(x) = 111\ 111\ 111\ 111\ 111\ 111\ 110\ 001\ 001\ 011$$

8 Codeword interleaving

The message partition consists of a number of codeblocks (see subclause 5.4). A codeblock shall be assembled from nine message codewords interleaved such that each of the codewords constitutes a row of a nine row by thirty column matrices as shown below.

CODEWORD	MSB			LSB																								
1	C _{1,29}	C _{1,28}	C _{1,27}	C _{1,26}	C _{1,25}	C _{1,24}	C _{1,23}	C _{1,22}	C _{1,21}	C _{1,20}	C _{1,1}	C _{1,0}															
2	C _{2,29}	C _{2,28}	C _{2,27}	C _{2,1}	C _{2,0}																							
3	C _{3,29}	C _{3,28}	C _{3,27}	C _{3,1}	C _{3,0}																							
4	C _{4,29}	C _{4,28}	C _{4,27}	C _{4,1}	C _{4,0}																							
5	C _{5,29}	C _{5,28}	C _{5,27}	C _{5,1}	C _{5,0}																							
6	C _{6,29}	C _{6,28}	C _{6,27}	C _{6,1}	C _{6,0}																							
7	C _{7,29}	C _{7,28}	C _{7,27}	C _{7,1}	C _{7,0}																							
8	C _{8,29}	C _{8,28}	C _{8,27}	C _{8,1}	C _{8,0}																							
9	C _{9,29}	C _{9,28}	C _{9,27}	C _{9,1}	C _{9,0}																							

The bits shall be sent to the modulator column by column so the transmit order is as follows:

C_{1,29} C_{2,29} C_{3,29} C_{4,29} C_{5,29} C_{6,29} C_{7,29} C_{8,29} C_{9,29} then,
C_{1,28} C_{2,28} C_{3,28} C_{4,28} C_{5,28} C_{6,28} C_{7,28} C_{8,28} C_{9,28} followed by
C_{1,27} C_{2,27} C_{3,27} C_{4,27} C_{5,27} C_{6,27} C_{7,27} C_{8,27} C_{9,27} and
C_{1,26} C_{2,26} C_{3,26} C_{4,26} C_{5,26} C_{6,26} C_{7,26} C_{8,26} C_{9,26} etc.
.....
..... until the final column is transmitted
C_{1,0} C_{2,0} C_{3,0} C_{4,0} C_{5,0} C_{6,0} C_{7,0} C_{8,0} C_{9,0}

9 Modulation

9.1 General

The air interface, which is the subject of this part of the specification, can support frequency divided, time divided or time and frequency divided modes of operation. All these implementations operate on common frequency channels with the same modulation format. Furthermore it is an operational requirement (see ETS 300 133-2 [1]) that paging receivers work throughout the system radio coverage area regardless of the prevailing time/frequency division mode. The radio related aspects of these requirements are addressed in this Clause.

9.2 RF channels and channel numbering

The paging system shall operate in the frequency band 169,4125 MHz to 169,8125 MHz. The channel spacing shall be 25 kHz. The nominal frequencies and channel numbers shall be defined by the following expression:

$$f_n = 169,425 + n \cdot 0,025 \text{ MHz}$$

$$n = \text{channel number} = 0 \text{ to } 15$$

Co-ordination between paging areas and the corresponding propagation criteria shall comply with CEPT Recommendation T/R 25-07 [5], Annex 1.

9.3 Modulation format

The modulation format shall be 4-PAM/FM.

The modulated signal shall be equivalent to that obtained with the following block diagram.

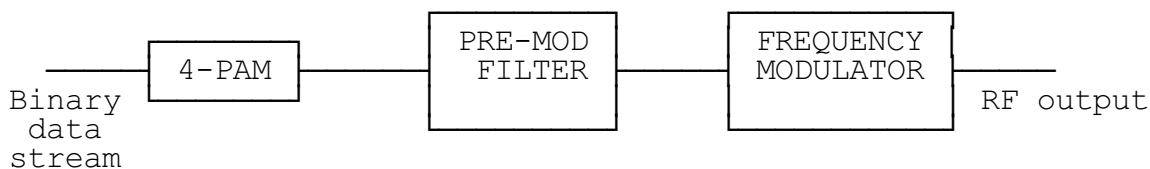

Four level pulse amplitude modulated FM is a technique where the communication of two data bits is achieved by the transmission of one of four signalling frequencies. A continuous phase and premodulation pulse shaping of the data stream constrain the transmitted RF spectrum. To minimise bit errors Gray code mapping between the dibit symbols and the signalling frequencies is employed.

Digit symbols are sent to the modulator beginning with the two bits from the MSB end of the codewords.

9.3.1 Symbol alphabet

The following symbol mapping of the signal shall be implemented:

Nominal frequency	Symbol
carrier + 4687,5 Hz	10
carrier + 1562,5 Hz	11
carrier - 1562,5 Hz	01
carrier - 4687,5 Hz	00

9.3.2 Data rate and symbol rate

The following basic system parameters shall apply:

Data rate	6,25 kbits/s
Symbol rate	3,125 kbaud

9.3.3 Premodulation pulse shaping

The premodulation pulse shaping is defined by the amplitude and group delay masks shown below:

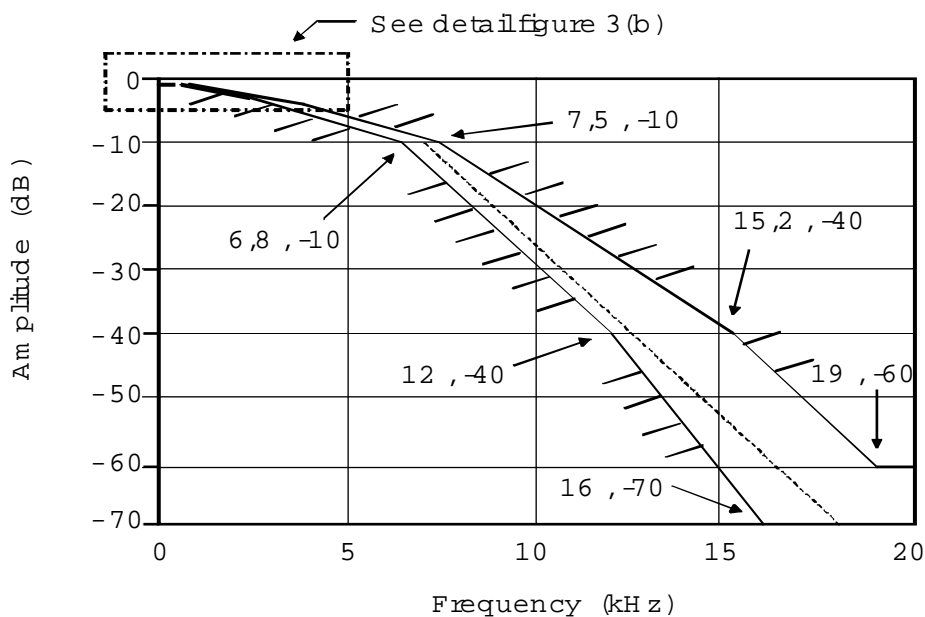

Figure 3(a): Upper and lower masks for the 4-PAM/FM premodulation filter. The dashed curve is the shape of the 10th order low pass Bessel filter with the 3 dB bandwidth of 3,9 kHz.

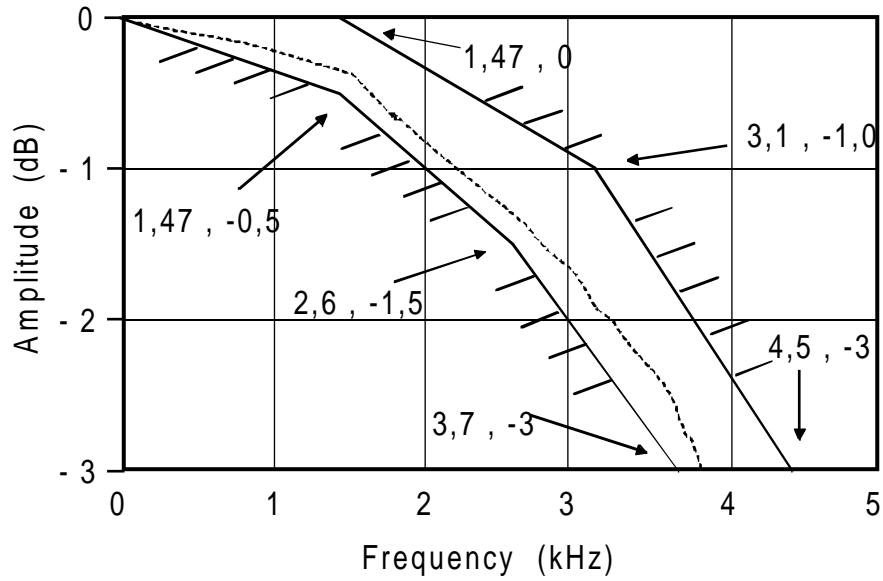

Figure 3(b): Detail expansion of above low pass filter characteristic.

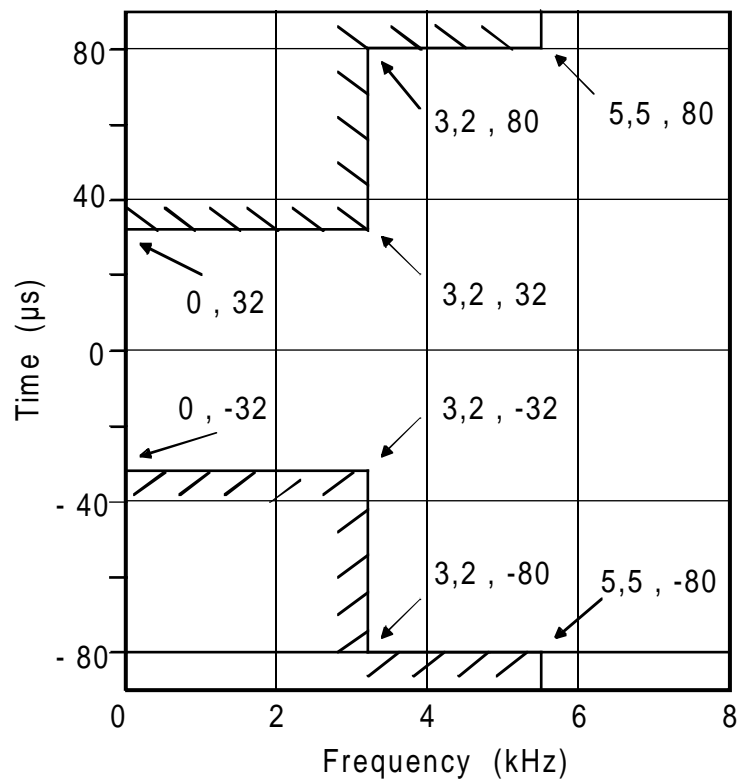

Figure 3(c): Group delay mask for the 4-PAM/FM premodulation filter.

9.3.4 Paging receiver performance

The paging receiver shall comply with the requirements specified in ETS 300 133-5 [2].

9.3.5 Transmitter performance

Transmitter characteristics shall comply with the requirements specified in ETS 300 133-6 [3].

10 Operation of the radio subsystem

10.1 General

The transmission protocol specified in Clause 5 has sufficient flexibility to support time and/or frequency divided operation.

In a time divided network, paging area coverage is provided using different subsequences (from the same cycle) for each paging area. Transmissions on the same frequency for each batch type shall occur at least once every minute in areas where coverage is offered. Adjacent paging areas may transmit on different subsequences to avoid interference between neighbouring areas using the same frequency. This is illustrated by the following figure:

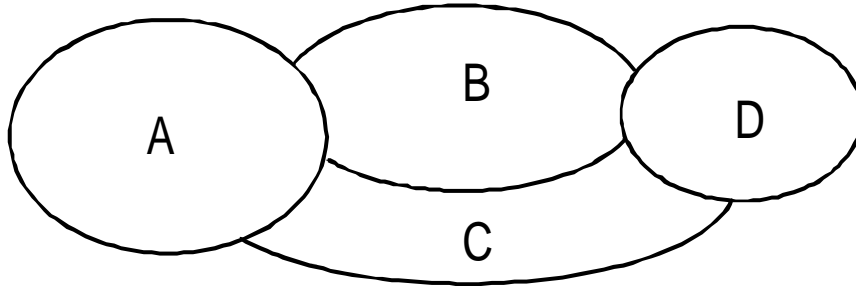

Paging areas A and D have the most traffic and so transmit on the first three subsequences. Areas B and C use one subsequence each. Areas B and C provide the necessary physical separation to prevent interference between areas A and D which transmit simultaneously on the same frequency.

Figure 4: Time divided network

Frequency divided network operation implies that adjacent paging areas use different frequencies. No time sharing between paging areas should be used. Within the home network a receiver should use different frequencies in different paging areas.

When the paging area is adjacent to a network operator boundary the border area indicator bit may be set to one in the system information partition. This signifies that a receiver associated with that network may expect to receive a call from an alternative network and should then take the appropriate action (see subclause 10.3).

The external traffic indicator shall be set to one in the system information partition to indicate to receivers who can not find their home network that there may be messages for them in this batch.

10.2 Frequency subset indicator and frequency subset number

In multifrequency networks the paging receiver is informed on which channel to expect its messages. This is accomplished with a combination of the frequency subset indicator (FSI) transmitted in the system information partition and the frequency subset number (FSN) permanently stored in the receiver. The frequency subset indicator shall be transmitted for all receivers in home or external networks.

All receivers shall be assigned an FSN between 0 and 15. Each FSN defines a unique subset of five FSIs as indicated in figure 5. Each FSI defines a unique subset of FSNs to which the transmitted message may be directed. It is intended that the FSI shall be used in descending order. Thus in single channel networks the transmitted FSI shall be set to 30. In two channel networks the transmitted FSI shall be set to 28 and 29. The FSI/FSN arrangement offers the possibility to have a dynamic number of channels in use.

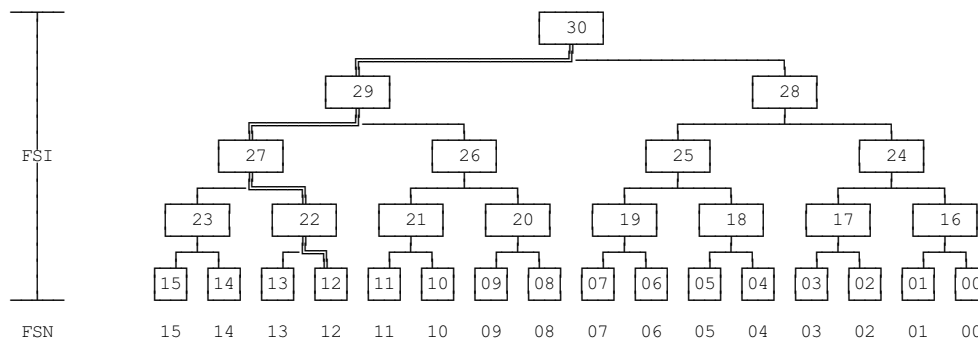

Figure 5: Illustrates FSI subsets

The FSI broadcast on the paging channel indicates that messages will be transmitted for pagers with an FSN in that FSI's subset. For example when the FSI on a channel equals 27 (see figure 5) only messages to receivers with FSNs of 12, 13, 14 or 15 will be carried. Conversely a receiver with FSN=12 should look for its messages only on channels broadcasting FSI values of 12, 22, 27, 29 or 30.

The FSNs do not correspond directly to frequency channel numbers.

10.3 Border area indicator

The Border Area Indicator (BAI) is relevant only in a receiver's home network. When BAI=1 home receivers should not lock to this channel (see subclause 10.5.2). If the BAI is set to zero valid traffic is expected to be carried by the home network only.

When the BAI is set to zero and the service area and the roaming area are adjacent or overlapping and are using different channels, the calls may be transmitted in both areas.

10.4 External traffic indicator

The External Traffic Indicator (ETI) indicates whether the initial address of any external receivers will be sent in the address partition of the batch. When the ETI is set to 1, one or several initial addresses of external receivers shall be sent in the batch. When the ETI is set to 0 external receivers need not look for their initial address in that batch. The ETI shall be valid only for a particular batch and shall be updated in subsequent batches.

10.5 Examples of receiver operation

Various receiver designs may be used in the ERMES system provided they conform with the requirements of ETS 300 133-5 [2]. Examples of non-locking and locking receivers will be described in this subclause.

10.5.1 Non-locking receivers

A non-locking receiver would not lock to a specific channel. It would check all home network channels or all sixteen channels at specific intervals as directed by information stored in the receiver and paging network controller (see Clause 12). The non-locking receiver will check all 16 channels according to the battery saving techniques in Clause 12.

10.5.2 Locking receiver

A locking receiver may store information about some subscribed and/or roamed networks or paging areas. This information may be conveyed to the receiver using the remote programming facility described in subclause 11.7. A locking receiver will lock to a channel if all of the following criteria are satisfied:

- (1) The relevant network information eg. OPID, PA, FSI is received on the channel;
- (2) The BAI is set to zero in all subsequences;
- (3) The quality of reception on the channel is sufficient.

If any of these conditions are not met the locking receiver would act as a non-locking receiver.

11 Paging message procedures on the air interface

11.1 General

The information format specified in Clause 6 allows several simple format choices to be associated together to form a procedure. The more common of these procedures are described in this Clause starting with individual calls, progressing to group calls, long messages and finally describing remote programming of receiver parameters. Whilst these procedures are themselves considered separately there are no restrictions in the protocol to limit the use of, for example, sending a long message as a group call or remotely programming the paging parameters of a group.

11.2 Individual call procedure

Individual calls to mobile subscribers shall be processed in two distinct stages.

- 1) During the first stage the called receiver shall be initially addressed in its own batch and start searching for its local address in the current and subsequent batches. Initial addresses appear in the address partition of the air interface transmissions as illustrated in subclause 5.4. In the event of messages being sent to receivers with identical initial addresses or more than one message being sent to a single receiver, then the initial address shall be transmitted once for each message.
- 2) During the second stage the called receiver shall be sent, in the message partition of the same or subsequent batches, an individual message to its local address or OPID plus local address if outside of its home network. This secondary addressing information is contained in the message header described in subclause 6.5.1. The individual message number is also contained in the message header along with the external bit, the additional information indicator (AII) and variable information field (VIF). The message number should be incremented by one from the previously transmitted message number and the other parameters set as appropriate for the transmitted message paging category and information types as specified in subclause 6.5.

Numeric data (four bit characters as defined in ETS 300 133-5 [2], Annex C, Clause C.1), alphanumeric data (seven bit characters as defined in ETS 300 133-5 [2], Annex C, Clause C.2), and transparent data shall follow immediately after the message header (or OPID and AIF if they are present). Completion of message codewords is specified in subclause 5.5. The message delimiter is specified in subclause 6.5.3. The following example serves to illustrate the procedure.

An F batch receiver is sent its initial address in the address partition (a receiver can only be sent its initial address in its own batch). On recognition of its initial address the receiver continues to listen to subsequent batches until it has received the message or the time-out criteria defined in subclause 11.6 are satisfied. The receiver is sent its message in the message partition of the same or any subsequent message partition (the H batch in this example). The receiver can recognise which is its message from the local address in the message header plus OPID if it is an external receiver.

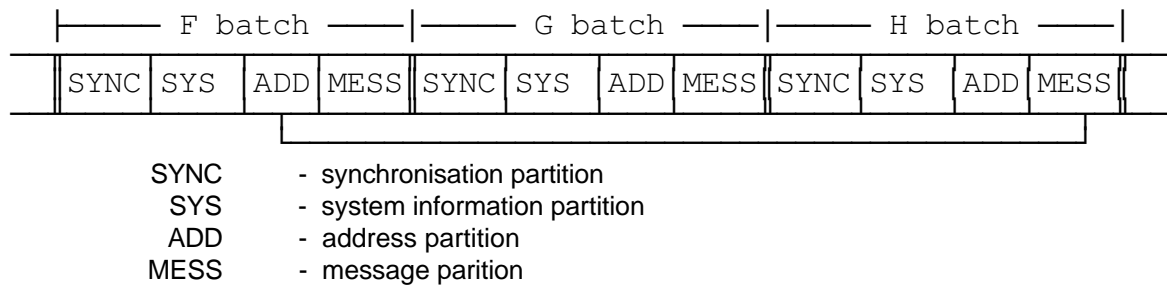

11.3 Group call procedure

Group calls to mobile subscribers using individual RICs shall be handled using the principle of the Common Temporary Address (CTA). This allows a short message (of two codewords length) to be sent to every receiver of the group and then the actual message (which may be much longer) need only be sent once to a common temporary address of which the receivers have already been individually informed. The procedure shall be performed in the following three stages:

- 1) during the first stage each receiver of the group shall be initially addressed in its own batch and start searching for its local address in subsequent batches;
- 2) during the second stage each receiver of the group shall be sent an individual message to its local address or full RIC if outside of its home area, with an individual message number, with the additional information indicator AII=1, additional information type AIT=111 and with the AIN corresponding to one of the sixteen common temporary address pointers (for instance AIN=0011).

Each receiver of the group shall append the four bits of the AIN to its internally stored or generated group initial address (comprising eighteen ones) to form the CTA.

The common temporary address shall be used by the receivers only for a single group call. All receivers of a group shall receive the same CTA;

- 3) at the third stage the actual message shall be sent only once using the common temporary address and a dummy message number 00000 in the message header. All other parameters of the message shall have the form of individual messages as specified in subclause 6.5. Receivers shall allocate to this message the appropriate message number transferred in the second stage of the procedure.

The form of the message headers at the second and third stages (see figure 6) serves to illustrate the procedure.

Second stage	Individual Local Address	Individual Message Number	External Bit (0 or 1)	AII (1)	AIT (111)	AIN (ctap no.)
Third stage	Common Temporary Address	Message Number (00000)	External Bit (0)	AII (0 or 1)	VIF	
No. of bits	22	5	1	1	7	

Figure 6: Contents of the fixed message headers for group calls

A dynamic example for two receivers belonging to the same group but of different batch types further illustrates the time related aspects of the procedure. Suppose that receiver No. 1 is an A batch receiver and receiver No. 2 is a B batch receiver. A typical transmission sequence could be as shown in figure 7.

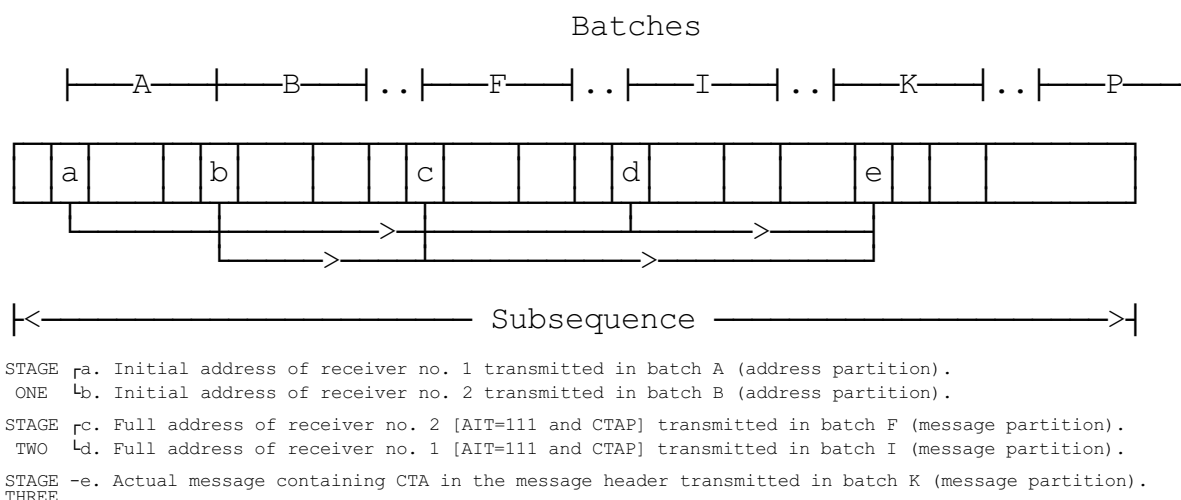

Figure 7: Typical on-air calling sequence for a group call on channel one

11.4 Handling of long messages

Long messages may be divided into submessages of variable length. The submessages shall be sent in order when transmitted on the radio path and all shall have the same message number. Each submessage shall be treated in the same way as a message.

In all submessages, the AII bit shall be set to 1 and the AIT set to 001. One of eight non-urgent or eight urgent alert types shall be chosen as indicated in subclause 6.5.1.2.1 and shall be the same for all submessages of the same message.

Information on the message structure is contained in the AIF. This has the form of a link counter. The link counter shall consist of 16 bits indicating the number of bits of the message that remain to be transmitted. Thus the maximum length of a transparent data message is 65535 bits, numeric message 16000 characters and alphanumeric message 9000 characters.

Each submessage shall be terminated as defined in subclause 6.5.3 and followed by a message delimiter. The receiver shall count the message bits it receives. EOM and filler bits shall not be counted as part of the message. When the message delimiter has been received the receiver should subtract the number of bits counted from the link counter. If the result is zero the complete message has been received. If the result differs from zero then the receiver knows that it can expect more submessages to be transmitted.

In a time divided network, where the long message is to be sent in different paging areas, there need be no coordination of transmission time nor submessage content between paging areas.

The following example shows an alphanumeric paging category message of length 10000 bits sent as three submessages. It is an urgent message with an alert signal indicator type 4.

First submessage: 2000 bits sent

All=1 AIT=001 AIN=1100 AIF = 10 00 10 01 11 00 01 00 00 (10000)

Second submessage: 5000 bits sent.

All=1 AIT=001 AIN=1100 AIF = 10 00 01 11 11 01 00 00 00 (10000-2000=8000)

Third submessage: 3000 bits sent.

All=1 AIT=001 AIN=1100 AIF = 10 00 00 10 11 10 11 10 00 (10000-(2000+5000)=3000)

11.5 Messages continued in further batches in the same subsequence

Messages may continue in further batches. If a message commences in one batch and continues in the next there shall be no message delimiter between the separate parts of the message. In the next batch the message shall be continued immediately after the address partition. A message may span several batches.

11.6 Messages continued in further subsequences

Messages may continue in further subsequences. If a message commences in one subsequence and continues in the next the same procedure as described in subclause 11.5 may be used. When a message is to be continued from one subsequence to another subsequence separated by a period of time equal to one or more subsequences the long message procedure shall be used.

11.7 Transmission of variable receiver parameters

Suitably equipped receivers may be remotely programmed via the air interface. The programming is performed by setting All=1 in the message header (see subclause 6.5.1), then setting AIT=010 in the variable information field (see subclause 6.5.1.2), followed by the appropriate AIN. The actual programming information is sent as the AIF following the message header (see subclause 6.5.2).

This facility may be used to change the internally stored receiver parameters listed under subclause 6.5.1.2.2.

The basic RIC shall be protected from erasure and corruption.

11.8 Termination of message search

When a receiver recognises a valid initial address it should begin to search for the associated paging message. If the message is not started within a defined time period due to data corruption or confusion with an external receiver possessing an identical local address, a defined end point for the message search shall occur as specified in the following subclauses.

11.8.1 Individual calls

Two time-out criteria shall apply. The earliest detected shall prevail:

- detection of a change in paging area code in the system information partition;
- 12 seconds since the start of the batch containing the initial address.

11.8.2 Group calls

Individual members of the group shall cease message search if:

- a change in paging area code in the system information partition is detected; or
- 12 seconds have elapsed since the start of the batch containing its initial address.

Consequently group messages should commence within 12 seconds from the start of the batch containing the initial address to the first member of the group.

Further group messages re-using the same CTAP should not be started within 12 seconds of the transmission of the beginning of the batch containing the initial address of the last member of the previous group using the CTAP. The group address can be reallocated after transmission of the group message has commenced but it should be ensured that transmission of the group message with duplicate group address does not commence until all previous timers have expired. These restrictions are illustrated in figure 8:

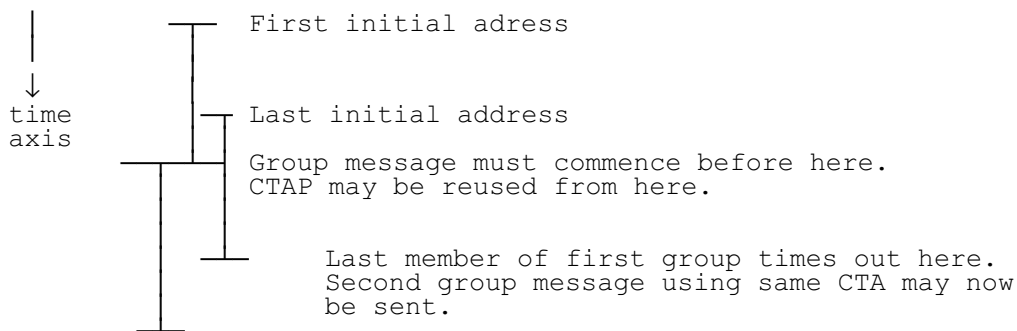

Figure 8: Time-out criteria for group calls

12 Battery saving techniques

12.1 Batch level

Battery saving on the batch level can be achieved by assigning a RIC at the high end of the addressable RIC population, since addressing is always performed in descending order with the highest initial address delivered first (see subclause 6.4). A receiver may switch off if it detects an initial address lower than its own in its batch type.

Assignment of RICs shall be decided by the network operator.

12.2 Subsequence level

Battery saving on the subsequence level is an inherent part of the protocol achieved by initially addressing the receiver in only one of the sixteen batches (A to P) in a subsequence.

12.3 Cycle level

Battery saving on the cycle level can be achieved by making the pager receive signals for only a subset of the five subsequences in a cycle.

The active subsequences for a particular pager shall be set by the subsequence mask SM (5 bits) stored in the pager. If any of the five bits is set to 1, signals should be expected on the corresponding subsequence. The MSB of SM corresponds to subsequence number 4, the LSB to subsequence number 0. The default value of SM stored in the pager shall be 11111.

If a subsequence indicated by the five bits is not used on a paging area that the pager receives signals for, the pager shall listen to the next (cyclically) used subsequence for that paging area.

This technique may not be appropriate for certain arrangements of time divided networks.

12.4 Sequence level

Battery saving on the sequence level can be achieved by making the pager receive signals for only a subset of the sixty cycles in a sequence.

The active cycles shall be determined by comparing the LSBs of the cycle number to the LSBs of the receiver's initial address. If they match then the cycle may carry initial addresses for the receiver.

The number of LSBs to be compared (in the range 0 to 5) shall be defined by two 3 bit numbers; HNL for operation within the home network and ENL for operation outside the home network. These values may be remotely changed in suitably equipped receivers (see subclause 11.7).

A value HNL=0 shall cause the receiver to be active in all cycles whilst HNL=1 shall cause the receiver to be active in every second cycle. For HNL=5 receivers with initial addresses ending in 00000 to 11011 shall be active in two out of sixty cycles whilst receivers with initial addresses ending in 11100 to 11111 shall be active in only one out of sixty cycles. This is summarised in the following table:

Number of LSBs to be compared	Value of HNL or ENL	Receiver active (per sequence)
0	000	all cycles
1	001	every 2nd cycle
2	010	every 4th cycle
3	011	every 8th cycle
4	100	every 16th cycle
5	101	every 32nd cycle

HNL and ENL shall be set to default values of 000 and 010 respectively.

13 Synchronisation

13.1 General

The requirements for synchronisation in the paging system have three different elements:

- between paging receivers and the radio transmissions on a single channel;
- between the transmissions of identical radio signals from different transmitters in a single paging area;
- between the transmissions on different radio channels particularly when controlled by different network operators.

13.2 Synchronisation between paging receiver and radio transmission

The paging system air interface is synchronous in that the start of radio transmissions to a particular receiver always occurs at fixed times. This method of operation requires that an accurate timer is incorporated into each paging receiver. The timing reference for this timer is provided by the radio transmission protocol. Details of the bit synchronisation and word synchronisation codes are specified in subclause 6.2.

13.3 Synchronisation between base stations

The paging area network operates in a quasi synchronous manner. Several transmitters within the paging area transmit the same information simultaneously in order to enhance system coverage.

The difference in time of reception consists of three parts:

- difference in delay in base stations;
- accuracy of synchronisation between base stations;
- difference in propagation times to the receiver.

Maximum adjacent base station separation results when the sum of the first two parts is kept as low as possible.

The maximum difference in times of reception of identical signals from different transmitters shall not exceed 50 μ s.

13.4 Co-ordination between networks

In order that paging receivers can successfully commute between different paging networks it is necessary for the timing of transmissions on the radio channels to be co-ordinated.

Transmissions by different networks shall be co-ordinated so that the start of transmissions of each of their cycles is within ± 2 ms of the common time reference (UTC). That is within 4 ms of each other.

Annex A (normative): List of country or area numbers

Zone 2

<i>Number</i>	<i>Country or Area</i>
202	Greece
204	Netherlands (Kingdom of the)
206	Belgium
208	France
212	Monaco
214	Spain
216	Hungarian People's Republic
220	Yugoslavia (Socialist Republic of)
222	Italy
226	Romania (Socialist Republic of)
228	Switzerland (Confederation of)
230	Czechoslovak Socialist Republic
232	Austria
234	United Kingdom of Great Britain
238	Denmark
240	Sweden
242	Norway
244	Finland
250	Union of Soviet Socialist Republics
260	Poland (People's Republic of)
262	Germany (Federal Republic of)
266	Gibraltar
268	Portugal
270	Luxembourg
272	Ireland
274	Iceland
276	Albania (Socialist People's Republic of)
278	Malta (Republic of)
280	Cyprus (Republic of)
284	Bulgaria (People's Republic of)
286	Turkey

Zone 3

<i>Number</i>	<i>Country or Area</i>
302	Canada
308	St Pierre and Miquelon
310	United States of America
330	Puerto Rico
332	Virgin Islands (USA)
334	Mexico
338	Jamaica
340	French Antilles
342	Barbados
344	Antigua
346	Cayman Islands
348	British Virgin Islands
350	Bermuda
352	Grenada
354	Montserrat

356	St Kitts
358	St Lucia
360	St Vincent and the Grenadines
362	Netherlands Antilles
364	Bahamas (Commonwealth of the)
366	Dominica
368	Cuba
370	Dominican Republic
372	Haiti (Republic of)
374	Trinidad and Tobago
376	Turks and Caicos Islands

Zone 4

<i>Number</i>	<i>Country or Area</i>
404	India (Republic of)
410	Pakistan (Islamic Republic of)
412	Afghanistan (Democratic Republic of)
413	Sri Lanka (Democratic Socialist Republic of)
414	Burma (Socialist Republic of the Union of)
415	Lebanon
416	Jordan (Hashemite Kingdom of)
417	Syrian Arab Republic
418	Iraq (Republic of)
419	Kuwait (State of)
420	Saudi Arabia (Kingdom of)
421	Yemen Arab Republic
422	Oman (Sultanate of)
423	Yemen (People's Democratic Republic of)
424	United Arab Emirates
425	Israel (State of)
426	Bahrain (State of)
427	Qatar (State of)
428	Mongolian People's Republic
429	Nepal
430	United Arab Emirates (Abu Dhabi)
431	United Arab Emirates (Dubai)
432	Iran (Islamic Republic of)
440	Japan
450	Korea (Republic of)
452	Viet Nam (Socialist Republic of)
454	Hong Kong
455	Macao
456	Democratic Kampuchea
457	Lao People's Democratic Republic
460	China (People's Republic of)
467	Democratic People's Republic of Korea
470	Bangladesh (People's Republic of)
472	Maldives (Republic of)

Zone 5

<i>Number</i>	<i>Country or Area</i>
502	Malaysia
505	Australia
510	Indonesia (Republic of)
515	Philippines (Republic of the)
520	Thailand
525	Singapore (Republic of)
528	Brunei
530	New Zealand
535	Guam
536	Nauru (Republic of)
537	Papua New Guinea
539	Tonga (Kingdom of)
540	Solomon Islands
541	Vanuatu
542	Fiji
543	Wallis and Futuna Islands
544	American Samoa
545	Gilbert & Ellice Islands
546	New Caledonia and Dependencies
547	French Polynesia
548	Cook Islands
549	Western Samoa

Zone 6

<i>Number</i>	<i>Country or Area</i>
602	Egypt (Arab Republic of)
603	Algeria (People's Democratic Republic of)
604	Morocco (Kingdom of)
605	Tunisia
606	Libya (Socialist People's Libyan Arab Jamahiriya)
607	Gambia (Republic of the)
608	Senegal (Republic of)
609	Mauritania (Islamic Republic of)
610	Mali (Republic of)
611	Guinea (Republic of)
612	Ivory Coast (Republic of the)
613	Upper Volta (Republic of)
614	Niger (Republic of the)
615	Togolese Republic
616	Benin (People's Republic of)
617	Mauritius
618	Liberia (Republic of)
619	Sierra Leone
620	Ghana
621	Nigeria (Federal Republic of)
622	Chad (Republic of the)
623	Central African Republic
624	Cameroon (Republic of)
625	Cape Verde (Republic of)
626	Sao Tome and Principe (Democratic Republic of)
627	Equatorial Guinea (Republic of)

628	Gabon Republic
629	Congo (People's Republic of the)
630	Zaire (Republic of)
631	Angola (People's Republic of)
632	Guinea Bissau (Republic of)
633	Seychelles
634	Sudan (Democratic Republic of the)
635	Rwanda (Republic of)
636	Ethiopia
637	Somali Democratic Republic
638	Republic of Djibouti
639	Kenya (Republic of)
640	Tanzania (United Republic of)
641	Uganda (Republic of)
642	Burundi (Republic of)
643	Mozambique (People's Republic of)
645	Zambia (Republic of)
646	Madagascar (Democratic Republic of)
647	Reunion (French Department of)
648	Zimbabwe (Republic of)
649	Namibia
650	Malawi
651	Lesotho (Kingdom of)
652	Botswana (Republic of)
653	Swaziland (Kingdom of)
654	Comoros (Islamic Federal Republic of the)
655	South Africa (Republic of)

Zone 7

<i>Number</i>	<i>Country or Area</i>
702	Belize
704	Guatemala (Republic of)
706	El Salvador (Republic of)
708	Honduras (Republic of)
710	Nicaragua
712	Costa Rica
714	Panama (Republic of)
716	Peru
722	Argentine Republic
724	Brazil (Federative Republic of)
730	Chile
732	Colombia (Republic of)
734	Venezuela (Republic of)
736	Bolivia (Republic of)
738	Guyana
740	Ecuador
742	Guiana (French Department of)
744	Paraguay (Republic of)
746	Suriname (Republic of)
748	Uruguay (Eastern Republic of)

History

Document history	
July 1992	First Edition
January 1996	Converted into Adobe Acrobat Portable Document Format (PDF)