



EUROPEAN
TELECOMMUNICATION
STANDARD

ETS 300 132-1

September 1996

Source: ETSI TC-EE

Reference: DE/EE-02001.1

ICS: 33.020

Key words: Power supply

**Equipment Engineering (EE);
Power supply interface at the input to
telecommunications equipment;
Part 1: Operated by alternating current (ac)
derived from direct current (dc) sources**

ETSI

European Telecommunications Standards Institute

ETSI Secretariat

Postal address: F-06921 Sophia Antipolis CEDEX - FRANCE

Office address: 650 Route des Lucioles - Sophia Antipolis - Valbonne - FRANCE

X.400: c=fr, a=atlas, p=etsi, s=secretariat - **Internet:** secretariat@etsi.fr

Tel.: +33 92 94 42 00 - Fax: +33 93 65 47 16

Copyright Notification: No part may be reproduced except as authorized by written permission. The copyright and the foregoing restriction extend to reproduction in all media.

© European Telecommunications Standards Institute 1996. All rights reserved.

Contents

| | |
|--|----|
| Foreword | 5 |
| 1 Scope | 7 |
| 2 Normative references | 8 |
| 3 Definitions and abbreviations | 9 |
| 3.1 Definitions | 9 |
| 3.2 Abbreviations | 9 |
| 4 Requirements | 10 |
| 4.1 Nominal value of the supply voltage | 10 |
| 4.2 Normal service voltage range at interface "A" | 10 |
| 4.3 Abnormal service voltage ranges at interface "A" | 10 |
| 4.3.1 Abnormal service voltage under steady-state conditions | 10 |
| 4.3.2 Recovery from steady state abnormal voltage | 11 |
| 4.4 Abnormal service voltage under temporary conditions | 11 |
| 4.5 Voltage changes due to the regulation of secondary voltage | 11 |
| 4.6 Supply protection at interface "A" | 11 |
| 4.7 Surge current on connection of interface "A" | 11 |
| 4.7.1 Limits | 11 |
| 4.7.2 Measurement method | 12 |
| 4.7.3 Protective device ratings | 13 |
| 5 Earthing and bonding | 13 |
| 6 Electrical safety requirements | 13 |
| 6.1 General | 13 |
| 7 EMC requirements | 13 |
| Annex A (informative): Information and guide on safety | 14 |
| Annex B (informative): Guide for measuring inrush current and for transferring the recorded pulses onto the limit chart | 15 |
| B.1 Measurement | 15 |
| B.2 Pulse waveform transformation | 15 |
| Annex C (informative): Identification of interface A | 17 |
| Annex D (informative): Bibliography | 18 |
| History | 19 |

Blank page

Foreword

This European Telecommunication Standard (ETS) has been produced by the Equipment Engineering (EE) Technical Committee of the European Telecommunications Standards Institute (ETSI).

This ETS details the requirements for the interface between telecommunications equipment and its power supply, and includes requirements relating to its stability and measurement. Normative references are also made to the safety aspects, in various IEC and CENELEC documents. Informative references and detailed measurement and test arrangements are contained in informative annexes.

This ETS consists of 2 parts as follows:

Part 1: "Operated by alternating current (ac) derived from direct current (dc) sources"

Part 2: "Operated by direct current (dc)"

| Transposition dates | |
|---|------------------|
| Date of adoption of this ETS: | 16 August 1996 |
| Date of latest announcement of this ETS (doa): | 31 December 1996 |
| Date of latest publication of new National Standard or endorsement of this ETS (dop/e): | 30 June 1997 |
| Date of withdrawal of any conflicting National Standard (dow): | 30 June 1997 |

Blank page

1 Scope

This European Telecommunication Standard (ETS) contains requirements for:

- the output performance of the (stabilized) ac power supply derived from dc sources as specified in ETS 300 132-2 [9]; and
- the input of the telecommunications equipment connected to interface "A", powered by ac not directly provided by the mains.

This ETS also makes reference to safety and EMC standards which are in accordance with the relevant European and international standards.

This ETS aims at providing compatibility between the power supply equipment and the power consuming telecommunications equipment, and also between different load units connected to the same power supply.

NOTE 1: To ensure satisfactory performance, the connection of telecommunications equipment into installations is subject to the prevailing conditions of that installation and is subject to the agreement of both parties.

NOTE 2: For dc power supply systems operated at a nominal voltage of $-48 V_{dc}$, ETS 300 132-2 is available.

The power supply interface, interface "A" of figure 1, is a physical point to which all the requirements are related. This point is situated between the power supply system(s) and the power consuming telecommunications equipment.

NOTE 3: Interface "A" is located at the power terminals of the telecommunications equipment. Subject to the installation preconditions, this point may be located at any other point between the power supply system and the telecommunications equipment by mutual agreement of both parties.

The requirements at interface "A" apply to:

- the output of the power supply equipment or power supply installation of telecommunications centres;
- the power supply input of telecommunications equipment installed at telecommunication centres;
- telecommunications equipment, installed in customers' premises, whose power interface "A" is also used by equipment requiring a supply to this specification.

NOTE 4: Normally there is more than one load unit connected to interface "A". In some of these cases interface "A" might undergo further restrictions with respect to noise limits or other disturbances.

NOTE 5: This ETS also gives requirements on disturbances on the power supply interface "A". However, continuous wave phenomena above 20 kHz are not covered within this ETS. ETS 300 386-1 [8] is applicable for this frequency range.

NOTE 6: The transients to which immunity is specified in this ETS are characterized by a high energy content such that electrical stress may be caused. Fast transients, the effects of which appear mainly as interference, are covered by ETS 300 386-1 [8].

NOTE 7: An example of a configuration in which the interface "A" is identified is given in annex C.

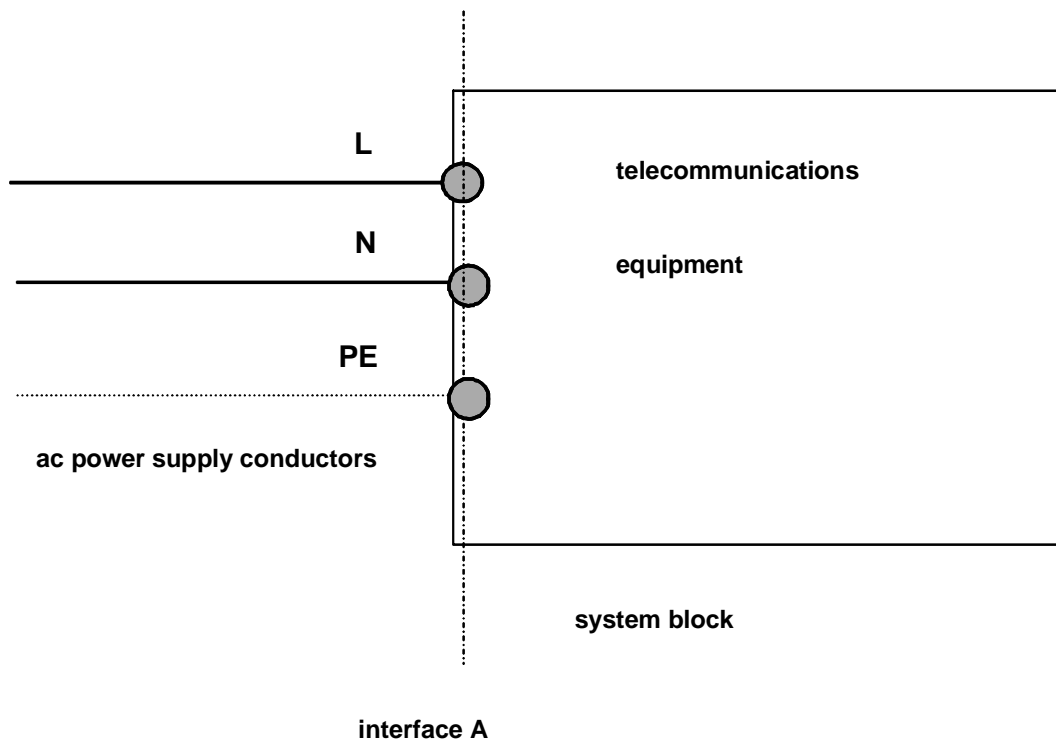

Figure 1: General identification of the power interface, interface "A"

The purpose of this ETS is:

- to enable the use of a power supply system with the same characteristics for all telecommunications equipment defined in the area of application;
- to facilitate interworking of different (types of) load units;
- to facilitate the standardization of telecommunications equipment;
- to facilitate the installation, operation and maintenance in the same network of equipment and telecommunications systems from different origins.

2 Normative references

This ETS incorporates by dated and undated reference provisions from other publications. These normative references are cited at the appropriate places in the text and the publications are listed hereafter. For dated references, subsequent amendments to or revisions of any of these publications apply to this ETS only when incorporated in it by amendment or revision. For undated references the latest edition of the publication referred to applies.

- [1] ETS 300 253: "Equipment Engineering (EE); Earthing and bonding of telecommunication equipment in telecommunication centres".
- [2] EN 41003 (1991): "Particular safety requirements for equipment to be connected to telecommunication networks".
- [3] EN 60950 (1992 amended 1993): "Safety of information technology equipment, including electrical business equipment".
- [4] IEC 38 (1983): "IEC standard voltages".
- [5] IEC 364-4-41 (1982): "Electrical installations of buildings - Part 4: Protection for safety - Chapter 41: Protection against electric shock".

- [6] IEC 664 (1992): "Insulation co-ordination for equipment within low voltage systems".
- [7] IEC 686 (1980): "Stabilized power supplies, ac output".
- [8] ETS 300 386-1 (1994): "Equipment Engineering (EE); Public telecommunication network equipment; Electro-Magnetic Compatibility (EMC) requirements; Part 1: Product family overview, compliance criteria and test levels".
- [9] ETS 300 132-2 (1996): "Equipment Engineering (EE); Power supply interface at the input to telecommunications equipment; Part 2: Operated by direct current (dc)".
- [10] IEC Publication 364-5-54: "Electrical installations of buildings - Part 5: Selection and erection of electrical equipment - Chapter 54: Earthing arrangements and protective conductors".

3 Definitions and abbreviations

3.1 Definitions

For the purposes of this ETS, the following definitions apply:

abnormal voltage range: The range of steady-state voltages over which the equipment will not be expected to maintain normal service but will survive undamaged.

interface "A": The terminals at which the ac power supply is connected to the telecommunications equipment (see figure 1).

NOTE 1: This is a functional definition and not an exact depiction of the physical location.

nominal load conditions: A set of values dedicated to a test performance.

nominal voltage value: The nominal value of the voltage that designates the type of supply.

normal service voltage range: The range of the steady-state voltage over which the equipment will maintain normal service.

normal service: The service mode where telecommunications equipment operates within its specification.

power supply: A power source to which telecommunications equipment is intended to be connected.

system block: A functional group of equipment depending for its operation and performance on its connection to the same power supply.

telecommunication centre: Any location where telecommunications equipment is installed and which is the sole responsibility of the operator.

3.2 Abbreviations

For the purposes of this ETS, the following abbreviations apply:

| | |
|-------|--|
| ac | alternating current (also when used as a suffix to units of measurement) |
| dc | direct current (also when used as a suffix to units of measurement) |
| EUT | Equipment Under Test |
| GEN | Generator |
| I_m | maximum current (see subclause 4.7.1) |
| I_t | instantaneous surge current (see subclause 4.7.1) |
| L | Line (of ac power supply) - figure 1 |

| | |
|------|---|
| L | inductance of inductive element of LISN - other than figure 1, and especially subclause 4.7.2 |
| LISN | Line Impedance Stabilization Network |
| N | Neutral (of ac power supply) |
| PE | Protective Earth |
| R | resistance of resistive element of LISN |
| rms | root mean square (also when used as a suffix to units of measurement) |
| t | time |

4 Requirements

A prerequisite is that the ac power supply providing power to interface "A" shall be of the stabilized type such as an inverter or an ac conditioner.

4.1 Nominal value of the supply voltage

The nominal value of the voltage at interface "A" shall be 230 V_{ac}.

4.2 Normal service voltage range at interface "A"

The normal service voltage range for an ac nominal supply at interface "A" is:

- 207,0 to 253,0 V_{ac}.

This value has to be observed between:

- the supply conductors of single-phase systems;
- the phase and neutral supply conductors of ("400 V") three-phase systems.

NOTE 1: For the mains nominal supply voltage this ETS complies with IEC Publication 38 [4].

NOTE 2: During a transitional period, IEC Publication 38 [4] reduces the upper tolerance limit of 10% to 6%, i.e. to 242,0 V. In addition, some users require the lower limit to be 198,0 V.

The standard frequency range for the normal service voltage range shall be 48 to 52 Hz.

NOTE 3: Certain peripheral equipments require a closer tolerance, typically ± 1 Hz or less. For this equipment a stabilized ac supply may be specified in accordance with IEC Publication 686 [7].

NOTE 4: Single-phase equipment may also be powered by multi-phase supplies, deviating from IEC Publication 38 [4], as long as the voltage between the active supply conductors are in accordance with this ETS.

4.3 Abnormal service voltage ranges at interface "A"

4.3.1 Abnormal service voltage under steady-state conditions

Telecommunications equipment operated by ac shall not suffer any damage when subjected to the following voltages ranges (rms values):

0 to 207,0 V_{ac}.

The frequency tolerance for 230/400 V_{ac}/50 Hz systems at abnormal service under steady state conditions shall be:

45 Hz to 55 Hz.

NOTE: Overvoltages are covered in EN 60950 [3] with respect to safety.

4.3.2 Recovery from steady state abnormal voltage

Following the restoration of the supply to the normal service voltage range, the power transformation and management systems of the power equipment connected to interface "A" shall automatically restore service. The telecommunications equipment shall then resume operation according to its specifications. The abnormal service voltage shall not lead to the disconnection of power supply units e.g. by causing circuit breakers, fuses or other such devices to operate.

4.4 Abnormal service voltage under temporary conditions

Abnormal service voltage under temporary conditions and surge testing simulating these temporary conditions are covered by ETS 300 386-1 [8].

4.5 Voltage changes due to the regulation of secondary voltage

Voltage interruptions of the ac power supply: where automatic switching is used to maintain continuity, short interruptions and fluctuations of the voltage measured at interface "A" may occur. The telecommunications equipment shall continue to function correctly when the duration of the interruption is less than or equal to 20 ms at nominal supply voltage.

Slow voltage fluctuations: in the case of regulation of the secondary voltage following load changes, slow voltage fluctuation and frequency variations may occur.

The telecommunications equipment shall continue to function correctly in accordance with its specification within the envelope of the voltage fluctuations shown below:

- static tolerance: $\pm 10\%$
- for < 500 ms with respect to the rms value: $\pm 15\%$
- for < 2 ms with respect to actual value: $\pm 40\%$

and within frequency variations of up to ± 3 Hz with a recovery time of 5 seconds or less.

4.6 Supply protection at interface "A"

The supply to interface "A" shall be protected by fuses or circuit breakers placed, for example, in a power distribution bay. Putting equipment into service shall not result in unwanted action from fuses, or any other protection devices.

4.7 Surge current on connection of interface "A"

4.7.1 Limits

The ratio of the instantaneous surge current I_t to maximum current I_m at interface "A", under any random sequence of switching operations, shall not exceed the limits shown in figure 2.

The parameters are defined as follows:

I_t inrush current (magnitude of instantaneous values);

I_m maximum input current (at ac rms), stated by the manufacturer, for a fully-equipped and loaded system block behind interface "A".

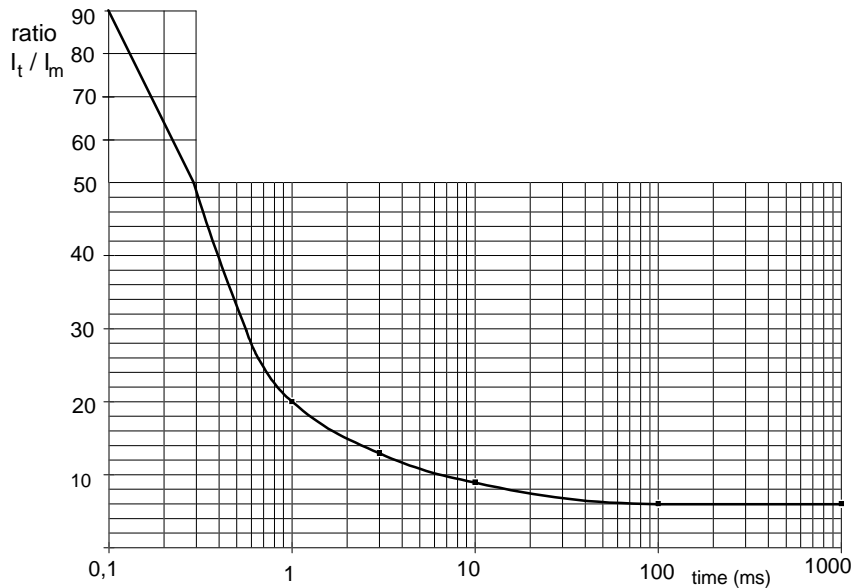

Figure 2: Maximum inrush current characteristics for telecommunications equipment

4.7.2 Measurement method

The circuit for measuring the surge current drawn by the equipment shall be as shown in figure 3. The measurement shall be made with the telecommunications equipment powered at the nominal secondary voltage and rated load condition (annex B gives guidance on taking these measurements).

Test conditions:

- If the current sensor is a resistor, the value of the resistance R shall be reduced by the value of the resistance of the current sensor.
- values for I_m , R and L are:
 - $R = 200 \text{ m}\Omega$ (approximately 10 metres $2 \times 1,5 \text{ mm}^2$ copper wiring);
 - $L = 10 \text{ }\mu\text{H}$ (approximately 10 metres $2 \times 1,5 \text{ mm}^2$ copper wiring);
 - I_m (as specified by the manufacturer).
- The impedance of the supply network depends on the impedance of the conductors and the fuses. While carrying out the surge current test, the rms ac voltage at the input of the LISN, as shown in figure 3, should remain within limits by using a power supply with a low impedance in relation to that of the LISN.

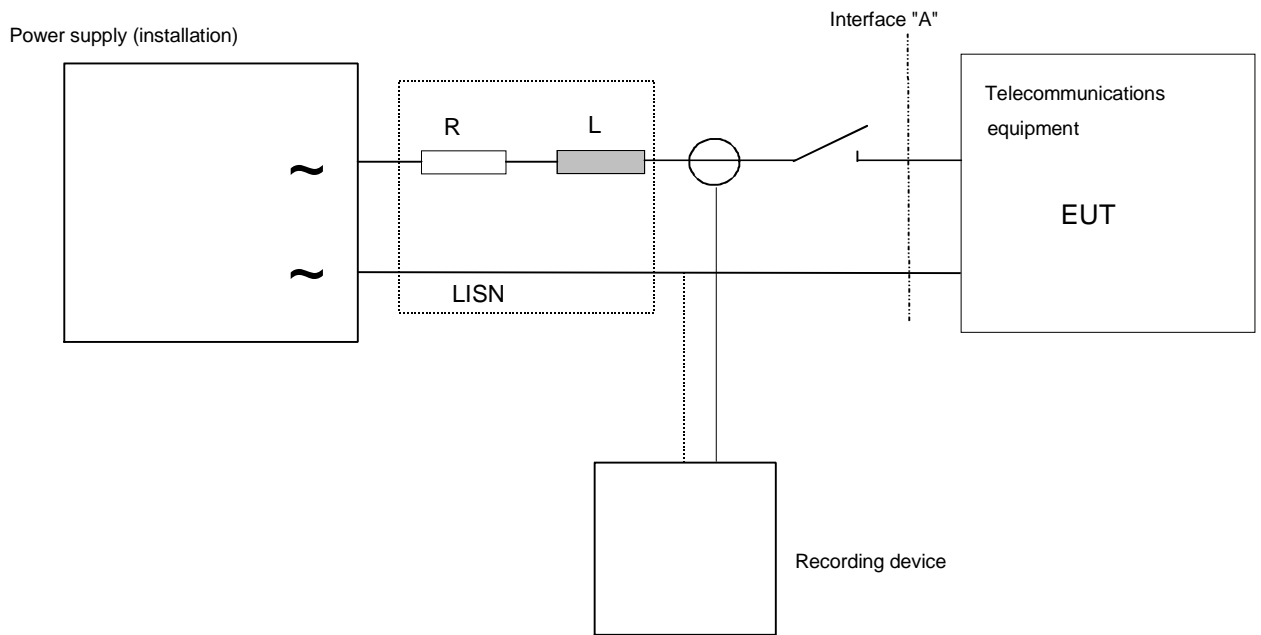

Figure 3: Surge current test circuit for ac interfaces

4.7.3 Protective device ratings

The energy content of the inrush characteristic shall be taken into account when specifying the equipment and the protective devices between the power plant and interface "A".

5 Earthing and bonding

Earthing and bonding of the telecommunications equipment in telecommunications centres is covered by ETS 300 253 [1].

6 Electrical safety requirements

6.1 General

At interface "A" the following safety requirements apply.

Table 1

| Nominal voltage | Requirement | Relevant standard |
|---------------------|---------------------------|-------------------|
| 230 V _{ac} | as for hazardous voltages | EN 60950 [3] |

7 EMC requirements

EMC requirements are covered by ETS 300 386-1 [8].

Annex A (informative): Information and guide on safety

- a) This ETS does not specify the safety requirements for either the telecommunications installation or the telecommunications equipment. These requirements are given in the following documents:
- for the installation: IEC 364-4-41 [5];
 - for the telecommunications equipment: EN 60950 [3].
- b) Where protective earthing is necessary (e.g., if Class 1 equipment is used) IEC Publication 364-5-54 [10] gives suitable requirements for safety. The protective earth should not rely on the telecommunications network.
- c) In situations where protective earthing does not exist, Class 1 equipment should not be connected to a telecommunications network except by use of a safety isolating transformer or other equivalent means. This arrangement should comply with the requirements of IEC Publication 364-4-41 [5] § 413.5 - Protection by electrical separation.
- d) In the case of equipment which is not designed primarily for telecommunications purposes, e.g. personal computers or television sets, precautions should be taken to ensure that those circuits which can be connected to the telecommunications network are in accordance with EN 41003 [2].

Annex B (informative): Guide for measuring inrush current and for transferring the recorded pulses onto the limit chart

B.1 Measurement

- Use a storage oscilloscope which can record values of di/dt of at least $10A/\mu s$.
- When measuring the ac supply, record the first or highest pulse. As with the dc measurements, a sufficiently long time-base should be used to allow pulse width measurements to be taken. The peak value of the pulse train for a duration of 1 second should be recorded (figure B.1 refers).
- Several readings should be taken to ensure that the worst case value is recorded.

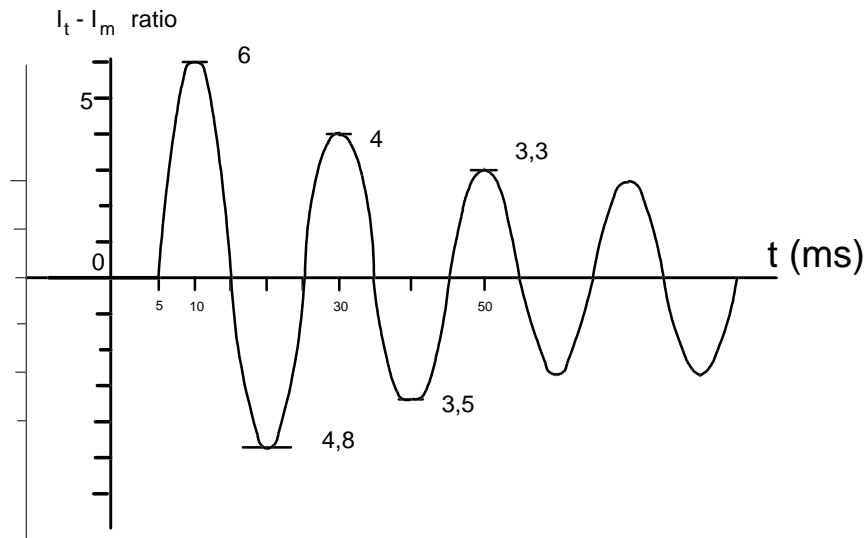

Figure B.1: Typical current pulse train and associated measurements

B.2 Pulse waveform transformation

- Pulse train.

For a pulse train from the ac supply measurements, (as in figure B.1) proceed as follows:

- use the pulse train from the worst case measurement;
- measure the peak value (I_t) of each pulse;
- produce the ratios for (I_t/I_m);
- plot the (I_t/I_m) values onto figure 2 using the start of the first pulse as reference for the time origin.

- Highest pulse from the ac system:

- measure the width of the current pulse at different levels;
- plot the current ratios against their corresponding time values onto figure 2.

- Figure B.2 shows the ac pulse train from figure B.1 transferred onto the limit chart of figure 2.

NOTE: Occasionally, more than one inrush pulse may appear, due to special arrangements for limiting the amplitude of single pulses or because the load (telecommunications equipment) starts in sequences. Under these conditions, the limit should be interpreted separately for each different start-up sequence where there is more than 1 second between each. The protective device in the distribution network should not operate.

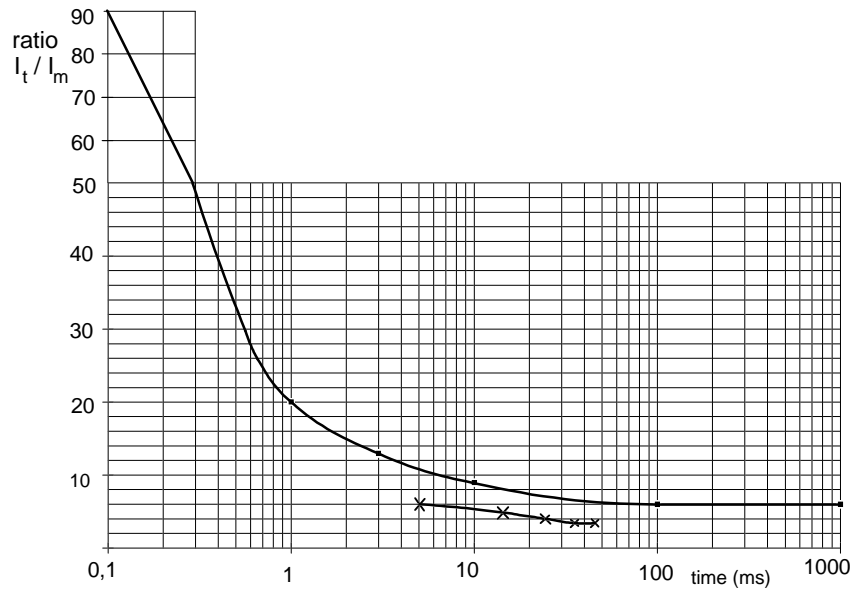

Figure B.2: Maximum values for typical inrush currents plotted against limit curve

Annex C (informative): Identification of interface A

Interface "A" is defined as the terminals at which the telecommunications equipment is connected to the power supply (installation). This is shown in figure C.1.

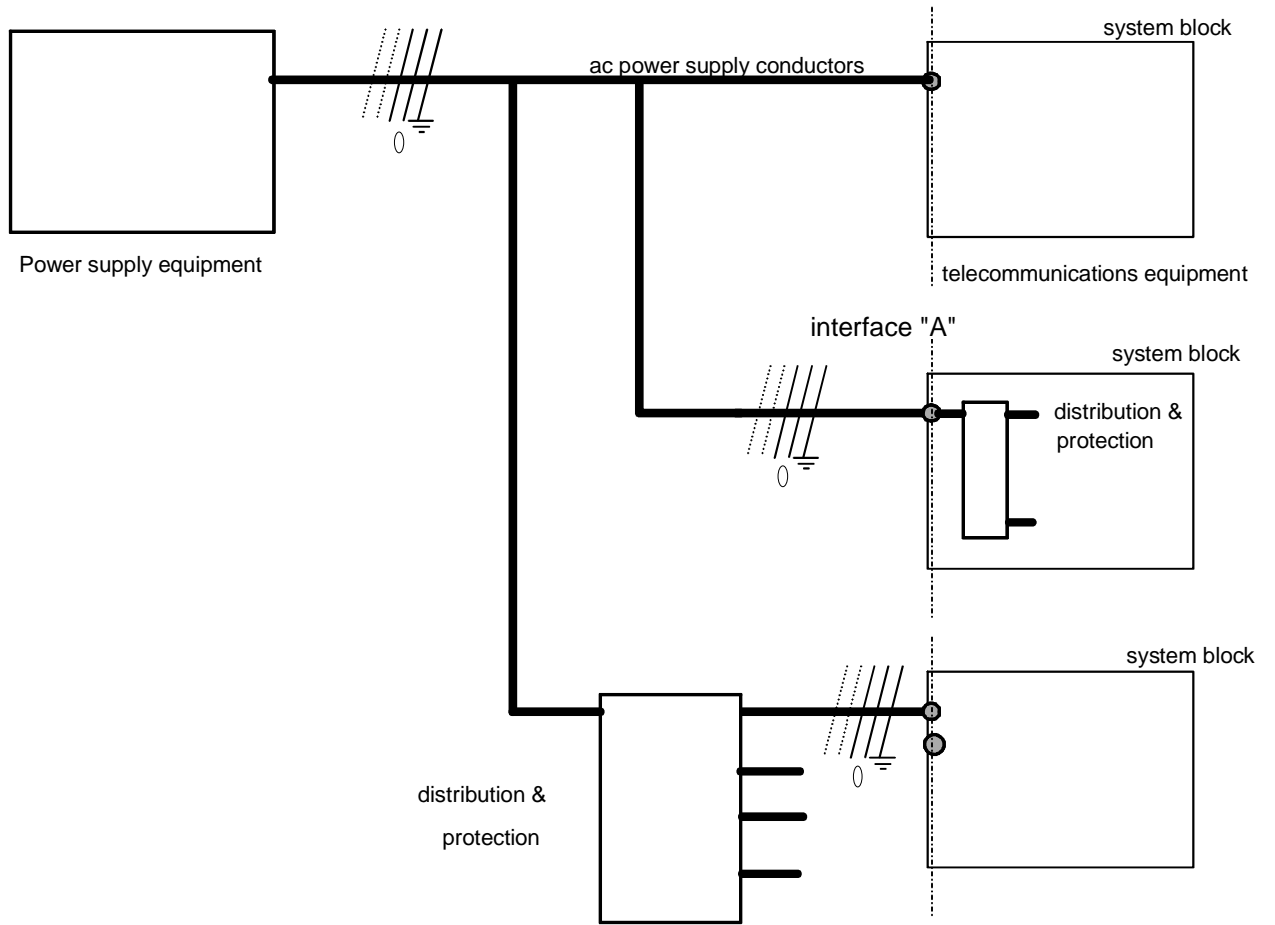

Figure C.1: Identification of interface "A"

Annex D (informative): Bibliography

- ITU-T Recommendation K.17: "Tests on power-fed repeaters using solid-state devices in order to check the arrangements for protection from external interference".
- prEN 50093 (1991): "Basic Immunity standard for voltage dips, short interruptions and voltage variations".
- EN 55022: "Limits and methods of measurement of radio disturbance characteristics of information technology equipment".
- EN 60555-1: "Disturbances in supply systems caused by household appliances and similar electrical equipment. Part 1: Definitions".
- EN 60555-2: "Disturbances in supply systems caused by household appliances and similar electrical equipment. Part 2: Harmonics".
- EN 60555-3: "Disturbances in supply systems caused by household appliances and similar electrical equipment. Part 3: Voltage fluctuations".
- IEC 801-4: "Electromagnetic compatibility for industrial-process measurement and control equipment - Part 4: Electrical fast transient/burst requirements".

History

| Document history | | | |
|------------------|----------------|--------|--------------------------|
| December 1991 | Public Enquiry | PE 17: | 1991-01-21 to 1995-05-17 |
| December 1994 | Public Enquiry | PE 75: | 1994-12-05 to 1995-03-31 |
| May 1996 | Vote | V 102: | 1996-05-06 to 1996-08-09 |
| September 1996 | First Edition | | |
| | | | |
| | | | |