



EUROPEAN
TELECOMMUNICATION
STANDARD

FINAL DRAFT
pr **ETS 300 113**

March 1996

Second Edition

Source: ETSI TC-RES

Reference: RE/RES-02012

ICS: 33.060.20, 33.060.50

Key words: Data, methodology, mobile, radio, speech, testing

**Radio Equipment and Systems (RES);
Land mobile service;
Technical characteristics and test conditions
for radio equipment intended for
the transmission of data (and speech)
and having an antenna connector**

ETSI

European Telecommunications Standards Institute

ETSI Secretariat

Postal address: F-06921 Sophia Antipolis CEDEX - FRANCE

Office address: 650 Route des Lucioles - Sophia Antipolis - Valbonne - FRANCE

X.400: c=fr, a=atlas, p=etsi, s=secretariat - **Internet:** secretariat@etsi.fr

Tel.: +33 92 94 42 00 - Fax: +33 93 65 47 16

Copyright Notification: No part may be reproduced except as authorized by written permission. The copyright and the foregoing restriction extend to reproduction in all media.

© European Telecommunications Standards Institute 1996. All rights reserved.

Contents

Foreword	9
Introduction	10
1 Scope	11
2 Normative references	12
3 Definitions, symbols and abbreviations	12
3.1 Definitions	12
3.2 Symbols	13
3.3 Abbreviations	13
4 General	14
4.1 Presentation of equipment for testing purposes	14
4.1.1 Choice of model for type testing	15
4.1.2 Definitions of alignment range and switching range	15
4.1.3 Definition of the categories of the alignment range (AR1 and AR2)	15
4.1.4 Choice of frequencies	15
4.1.5 Testing of single channel equipment of category AR1	15
4.1.6 Testing of single channel equipment of category AR2	16
4.1.7 Testing of two channel equipment of category AR1	16
4.1.8 Testing of two channel equipment of category AR2	16
4.1.9 Testing of multi-channel equipment (more than two channels) of category AR1	16
4.1.10 Testing of multi channel equipment (more than two channels) of category AR2 (switching range less than the alignment range)	17
4.1.11 Testing of multi channel equipment (more than two channels) of category AR2 (switching range equals the alignment range)	17
4.1.12 Testing of equipment without an external 50 Ω RF connector	17
4.1.12.1 Equipment with an internal permanent or temporary antenna connector	17
4.1.12.2 Equipment with a temporary antenna connector	17
4.2 Mechanical and electrical design	17
4.2.1 General	17
4.2.2 Controls	18
4.2.3 Transmitter shut-off facility	18
4.2.4 Marking	18
4.3 Testing using bit streams or messages	18
4.4 Interpretation of the measurement results	18
5 Technical characteristics	18
5.1 Transmitter parameter limits	18
5.1.1 Frequency error	18
5.1.2 Carrier power (conducted)	19
5.1.3 Effective radiated power	19
5.1.4 Adjacent channel power	20
5.1.5 Spurious emissions	20
5.1.6 Intermodulation attenuation	20
5.1.7 Transmitter attack time	21
5.1.8 Transmitter release time	21
5.1.9 Transient behaviour of the transmitter	21
5.1.9.1 Time domain analysis of power and frequency	21
5.1.9.2 Adjacent channel transient power	21
5.2 Receiver parameter limits	21
5.2.1 Maximum usable sensitivity (data or messages, conducted)	21

5.2.2	Average usable sensitivity (data or messages, field strength).....	22
5.2.3	Error behaviour at high input levels	22
5.2.4	Co-channel rejection.....	22
5.2.5	Adjacent channel selectivity.....	22
5.2.6	Spurious response rejection	22
5.2.7	Intermodulation response rejection	22
5.2.8	Blocking or desensitisation	23
5.2.9	Spurious radiations.....	23
5.3	Duplex operation - receiver limits.....	23
5.3.1	Receiver desensitisation and maximum usable sensitivity (with simultaneous transmission and reception)	23
5.3.2	Receiver spurious response rejection (with simultaneous transmission and reception).....	23
6	Test conditions, power sources and ambient temperatures.....	23
6.1	Normal and extreme test conditions.....	23
6.2	Test power source.....	24
6.3	Normal test conditions.....	24
6.3.1	Normal temperature and humidity	24
6.3.2	Normal test power source.....	24
6.3.2.1	Mains voltage	24
6.3.2.2	Regulated lead-acid battery power sources used on vehicles	24
6.3.2.3	Other power sources.....	24
6.4	Extreme test conditions.....	25
6.4.1	Extreme temperatures	25
6.4.2	Extreme test source voltages	25
6.4.2.1	Mains voltage	25
6.4.2.2	Regulated lead-acid battery power sources on vehicles	25
6.4.2.3	Power sources using other types of batteries	25
6.4.2.4	Other power sources.....	25
6.5	Procedure for tests at extreme temperatures	25
6.5.1	Procedure for equipment designed for continuous operation.....	26
6.5.2	Procedure for equipment designed for intermittent operation	26
7	General conditions.....	26
7.1	Arrangements for test signals applied to the receiver input.....	26
7.2	Receiver mute or squelch facility.....	26
7.3	Normal test signals (wanted and unwanted signals).....	27
7.4	Encoder for receiver measurements	27
7.5	Transceiver data interface.....	28
7.6	Impedance	28
7.7	Artificial antenna.....	28
7.8	Tests of equipment with a duplex filter.....	28
7.9	Facilities for access.....	28
7.9.1	Analogue access	28
7.9.2	Test points for bit stream measurements.....	28
7.9.3	Coupling arrangements	29
7.9.3.1	Arrangements for measurements with continuous bit streams	29
7.9.3.2	Arrangements for measurements with messages	29
7.10	Test site and general arrangements for measurements involving the use of radiated fields	29
7.11	Modes of operation of the transmitter	29
8	Methods of measurement for transmitter parameters	30
8.1	Frequency error.....	30
8.1.1	Definition.....	30
8.1.2	Method of measurement.....	30
8.2	Carrier power (conducted)	30
8.2.1	Definitions	30
8.2.2	Method of measurement.....	30
8.3	Effective radiated power (field strength).....	31

	8.3.1	Definition	31
	8.3.2	Method of measurement	32
8.4		Maximum permissible frequency deviation	34
	8.4.1	Definition	34
	8.4.2	Method of measurement	34
8.5		Adjacent channel power	34
	8.5.1	Definition	34
	8.5.2	Method of measurement	35
8.6		Spurious emissions	36
	8.6.1	Definition	36
	8.6.2	Method of measuring the power level	36
	8.6.3	Method of measuring the effective radiated power	37
8.7		Intermodulation attenuation	38
	8.7.1	Definition	38
	8.7.2	Method of measurement	39
8.8		Transmitter attack time	39
	8.8.1	Definition	39
	8.8.2	Method of measurement	40
8.9		Transmitter release time	40
	8.9.1	Definition	40
	8.9.2	Method of measurement	40
8.10		Transient behaviour of the transmitter	41
	8.10.1	Definitions	41
	8.10.2	Timings, frequencies and powers	42
	8.10.3	Methods of measurement	46
		8.10.3.1 Time domain measurements of power and frequency	46
		8.10.3.2 Test arrangement and characteristics of the test discriminator	47
		8.10.3.3 Adjacent channel transient power measurements	47
		8.10.3.4 Characteristics of the adjacent channel transient power measuring device	48
9		Methods of measurement for receiver parameters	49
	9.1	Maximum usable sensitivity (data or messages, conducted)	49
		9.1.1 Definition	49
		9.1.2 Method of measurement with continuous bit streams	49
		9.1.3 Method of measurement with messages	49
	9.2	Average usable sensitivity (data or messages, field strength)	50
	9.3	Level of the wanted signal for the degradation measurements (data or messages)	50
	9.4	Error behaviour at high input levels	51
		9.4.1 Definition	51
		9.4.2 Method of measurement with continuous bit streams	51
		9.4.3 Method of measurement with messages	51
	9.5	Co-channel rejection	52
		9.5.1 Definition	52
		9.5.2 Method of measurement with continuous bit streams	52
		9.5.3 Method of measurement with messages	53
	9.6	Adjacent channel selectivity	54
		9.6.1 Definition	54
		9.6.2 Method of measurement with continuous bit streams	54
		9.6.3 Method of measurement with messages	55
	9.7	Spurious response rejection	57
		9.7.1 Definition	57
		9.7.2 Introduction to the method of measurement	57
		9.7.3 Method of search over the "limited frequency range"	58
		9.7.4 Method of measurement with continuous bit streams	58
		9.7.5 Method of measurement with messages	59
	9.8	Intermodulation response rejection	60
		9.8.1 Definition	60
		9.8.2 Method of measurement with continuous bit streams	61
		9.8.3 Method of measurement with messages	62
	9.9	Blocking or desensitisation	63
		9.9.1 Definition	63

	9.9.2	Method of measurement with continuous bit streams	63
	9.9.3	Method of measurement with messages.....	64
9.10		Spurious radiations.....	65
	9.10.1	Definition.....	65
	9.10.2	Method of measuring the power level.....	66
	9.10.3	Method of measuring the effective radiated power.....	67
10		Duplex operation.....	68
	10.1	Receiver desensitisation (with simultaneous transmission and reception)	68
		10.1.1 Definition.....	68
		10.1.2 Desensitisation measured with continuous bit streams.....	69
		10.1.2.1 Method of measurement when the equipment has a duplex filter.....	69
		10.1.2.2 Method of measurement when the equipment has to operate with two antennas	70
		10.1.3 Desensitisation measured with messages	71
		10.1.3.1 Method of measurement when the equipment has a duplex filter.....	71
		10.1.3.2 Method of measurement when the equipment has to operate with two antennas	72
	10.2	Receiver spurious response rejection (with simultaneous transmission and reception)...	73
		10.2.1 Definition.....	73
		10.2.2 Method of measurement.....	73
11		Measurement uncertainty	74
Annex A (normative):		Radiated measurements.....	75
A.1		Test site and general arrangements for measurements involving the use of radiated fields	75
	A.1.1	Test site.....	75
	A.1.2	Test antenna	75
	A.1.3	Substitution antenna.....	76
	A.1.4	Optional additional indoor site	76
A.2		Guidance on the use of radiation test sites	77
	A.2.1	Measuring distance	77
	A.2.2	Test antenna	77
	A.2.3	Substitution antenna.....	77
	A.2.4	Artificial antenna.....	78
	A.2.5	Auxiliary cables	78
	A.2.6	Acoustic measuring arrangement	78
A.3		Further optional alternative indoor site using an anechoic chamber	78
	A.3.1	Example of the construction of a shielded anechoic chamber.....	78
	A.3.2	Influence of parasitic reflections in anechoic chambers.....	79
	A.3.3	Calibration of the shielded anechoic chamber	79
Annex B (normative):		Specification for some particular measurement arrangements.....	82
B.1		Power measuring receiver specification	82
	B.1.1	IF filter	82
	B.1.2	Attenuation indicator.....	83
	B.1.3	rms value indicator	83
	B.1.4	Oscillator and amplifier.....	83
B.2		Spectrum analyzer specification	83
B.3		Integrating and power summing device	83
Annex C (normative):		Identification.....	85
C.1		Scope.....	85

C.2	General.....	85
C.3	Position of the identification code.....	85
C.3.1	Base stations	85
C.3.1.1	System without windows	86
C.3.1.2	Systems with windows.....	86
C.3.2	Mobile stations	86
C.4	Bit rates and modulations.....	86
C.5	Format of the identification	87
C.6	Synchronisation	87
C.7	Code and block length.....	88
C.8	Contents of the identification block	89
C.8.1	Header	89
C.8.2	Country/regional code.....	89
C.8.3	National Information.....	90
C.8.3.1	Field description	91
C.8.3.2	Field size options.....	91
C.8.3.3	Options for the organisation of the fields.....	91
C.8.3.4	Examples of user/system information usage	92
C.9	Combinations	92
C.9.1	List of possible combinations.....	92
C.9.2	Relations between country/regional code and allowed combinations.....	92
C.9.3	Interpretation of the fields of the ID block	93
Annex D (informative):	Graphic representation of the selection of equipment and frequencies for testing	95
Annex E (informative):	Information on modulation, coding and format.....	97
Annex F (informative):	Bibliography	98
History.....		99

Blank page

Foreword

This final draft European Telecommunication Standard (ETS) has been produced by the Radio Equipment and Systems (RES) Technical Committee of the European Telecommunications Standards Institute (ETSI), and is now submitted for the Voting phase of the ETSI standards approval procedure.

This ETS is based upon CEPT Recommendation T/R 24-01 [1] and I-ETS 300 113 [6], and is complementary to ETS 300 086 [2], which covers radio equipment for use in the land mobile service and intended primarily for analogue speech.

This is a general ETS which may be superseded or complemented by specific standards addressing specific applications. It applies to equipment designed to operate within the professional mobile radio service and to the associated frequency planning.

Access protocols for equipment covered by this ETS are the subject of other ETSI standards such as ETS 300 471 [8].

This ETS is voluntary in application, however, it can be made mandatory by national Administrations as a part of the conditions attached to the issue of licenses for the use or sale of radio apparatus.

Annex A: is normative and provides additional information concerning radiated measurements.

Annex B: is normative and gives the requirements for equipment to be used for the measurements of adjacent channel power.

Annex C: is normative and presents the technical characteristics to be fulfilled, when required by the appropriate national regulatory authority, for the identification of stations type approved for professional mobile radio systems, that do not comply with other system protocols (e.g. trunking protocols); it is the responsibility of the manufacturer to ensure that the modulation that he has chosen for the identification, in accordance with the tables of this annex fulfils the requirements corresponding to the channels where the equipment is designed to operate, as specified in the main body of this ETS. The tables of this annex are expected to be updated regularly in order to reflect the progress accomplished in the field of mobile data transmissions.

Annex D: is informative and gives a graphic representation of subclauses 4.1.5 to 4.1.11, referring to the presentation of equipment for testing purpose.

Annex E: is informative and provides guidance concerning the technical characteristics of the modulation, coding and format.

Annex F is informative and contains a Bibliography.

Proposed transposition dates	
Date of latest announcement of this ETS (doa):	3 months after ETSI publication
Date of latest publication of new National Standard or endorsement of this ETS (dop/e):	6 months after doa
Date of withdrawal of any conflicting National Standard (dow):	6 months after doa

Introduction

This ETS is intended to specify the minimum performance and the methods of measurement of radio equipment for use in the land mobile service as specified in the scope.

Clause 5 provides the corresponding limits. These limits have been chosen to ensure an acceptable grade of service and to minimise harmful interference to other equipment and services. They are based on the interpretation of the measurement results given in subclause 4.4.

This ETS may be used by accredited test laboratories for the assessment of the performance of the equipment. The performance of the equipment submitted for type testing should be representative of the performance of the corresponding production model. In order to avoid any ambiguity in that assessment, this ETS contains instructions for the presentation of equipment for type testing purposes in clause 4, methods of measurement in clauses 8, 9 and 10, and conditions in clauses 6 and 7.

This ETS may also be used by monitoring services in particular for the identification of stations (see annex C).

This ETS was drafted on the assumption that:

- type test measurements performed in an accredited testing laboratory in one country would be accepted by the Administration in another country provided that the national regulatory requirements are met (in accordance to CEPT Recommendation T/R 71-03 [7]);
- if equipment available on the market is required to be checked it should be tested in accordance with the methods specified in this ETS.

All transmissions from equipment conforming to this ETS should include at specified moments, information establishing the identity of the transmitter.

The means of system identification should be approved by the appropriate national regulatory authority.

1 Scope

This European Telecommunication Standard (ETS) covers the minimum characteristics considered necessary in order to make the best use of the available frequencies. It does not necessarily include all the characteristics which may be required by a user, nor does it necessarily represent the optimum performance achievable.

This ETS applies to constant envelope angle modulation systems for use in the land mobile service, using the available bandwidth, operating on radio frequencies between 30 MHz and 1 GHz, with channel separations of 12,5 kHz, 20 kHz and 25 kHz intended for data transmissions. It applies to digital and combined analogue and digital radio equipment with an internal or external antenna connector intended for the transmission of data and/or speech.

The particular type of modulation will be chosen by the manufacturer, although it is recognised that in some countries national legislation may limit the use of certain code structures/data formats.

The technical characteristics given in this ETS are independent of data rate but may in practice limit the maximum data rate achievable. Future editions of this ETS are being prepared to allow complex modulation methods, together with their appropriate limits, for use at higher bit rates.

In this ETS different requirements are given for the different radio frequency bands, channel separations, etc. where appropriate.

In this ETS, data transmission systems are defined as systems which transmit and/or receive data. The equipment comprises a transmitter and associated encoder and modulator and/or a receiver and associated demodulator and decoder.

The types of equipment covered by this ETS are as follows:

- base station (equipment fitted with an antenna socket, intended for use in a fixed location);
- mobile station (equipment fitted with an antenna socket, normally used in a vehicle or as a transportable);
- and those handportable stations:
 - a) fitted with an antenna socket; or
 - b) without an external antenna socket (integral antenna equipment), but fitted with a permanent internal or a temporary internal 50 Ω Radio Frequency (RF) connector which allows access to the transmitter output and the receiver input.

Handportable equipment without an external or internal RF connector and without the possibility of having a temporary internal 50 Ω RF connector is not covered by this ETS.

Additional standards or specifications may also be required for equipment such as that intended for connection to the Public Switched Telephone Network (PSTN), or data networks.

Channel separations, maximum transmitter output power/effective radiated power, class of transmitter intermodulation attenuation, bit rates and the use of digitised speech may be conditions to the issue of a licence by the appropriate Administration.

Requirements to be fulfilled by equipment designed to meet several ETSs can be found in clause 4.

2 Normative references

This ETS incorporates by dated or undated reference, provisions from other publications. These normative references are cited at the appropriate places in the text and the publications are listed hereafter. For dated references subsequent amendments to or revisions of any of these publications apply to this ETS only when incorporated in it by amendment or revision. For undated references the latest edition of the publication referred to applies.

- [1] CEPT Recommendation T/R 24-01: "Specifications of equipments for use in the Land Mobile Service".
- [2] ETS 300 086: "Radio Equipment and Systems (RES); Land mobile group; Technical characteristics and test conditions for radio equipment with an internal or external RF connector intended primarily for analogue speech".
- [3] ETS 300 390 (1996): "Radio Equipment and Systems (RES); Land mobile service; Technical characteristics and test conditions for radio equipment intended for the transmission of data (and speech) and using an integral antenna".
- [4] ETR 028 (1994): "Radio Equipment and Systems (RES); Uncertainties in the measurement of mobile radio equipment characteristics".
- [5] CCITT Recommendation O.153: "Basic parameters for the measurement of error performance at bit rates below the primary rate".
- [6] I-ETS 300 113 (1992): "Radio Equipment and Systems (RES); Land mobile service; Technical characteristics and test conditions for non-speech and combined analogue speech/non-speech equipment with an internal or external antenna connector, intended for the transmission of data".
- [7] CEPT Recommendation T/R 71-03: "Procedures for type testing and approval for radio equipment intended for non-public systems".
- [8] ETS 300 471: "Radio Equipment and Systems (RES); Land mobile service; Access protocol, occupation rules and corresponding technical characteristics of radio equipment for the transmission of data on shared channels".

3 Definitions, symbols and abbreviations

3.1 Definitions

For the purposes of this ETS, the following definitions apply.

base station: Equipment fitted with an antenna socket, for use with an external antenna, and intended for use in a fixed location.

mobile station: Mobile equipment fitted with an antenna socket, for use with an external antenna, normally used in a vehicle or as a transportable station.

handportable station: Equipment either fitted with an antenna socket or integral antenna, or both, normally used on a stand-alone basis, to be carried on a person or held in the hand.

integral antenna: An antenna designed to be connected to the equipment without the use of a 50 Ω external connector and considered to be part of the equipment. An integral antenna may be fitted internally or externally to the equipment.

angle modulation: Either phase modulation or frequency modulation.

full tests: In all cases except where qualified as "limited", tests shall be performed according to this ETS.

limited tests: As required by subclause 4.1, the limited tests are:

- transmitter frequency error, subclause 8.1;
- transmitter carrier power (conducted), subclause 8.2;
- transmitter effective radiated power, subclause 8.3, integral antenna equipment only;
- transmitter adjacent channel power, subclause 8.5;
- receiver maximum usable sensitivity (conducted): subclause 9.1;
- receiver average usable sensitivity (field strength), subclause 9.2, integral antenna equipment only;
- receiver adjacent channel selectivity, subclause 9.6.

conducted measurements: Measurements which are made using direct 50 Ω connection to the equipment under test.

radiated measurements: Measurements which involve the absolute measurement of a radiated field.

bit: Binary digit.

block: The smallest quantity of information that is sent over the radio channel. A constant number of useful bits are always sent together with the corresponding redundancy bits.

packet: One block or a contiguous stream of blocks sent by one (logical) transmitter to one particular receiver or one particular group of receivers.

transmission (physical): One or several packets transmitted between power on and power off of a particular transmitter.

window: A set of inter-related transmissions which may be limited in time by an appropriate access protocol and corresponding occupation rules.

session: A set of inter-related exchange of packets occupying one or several windows or part thereof (if applicable). It corresponds to a complete interactive procedure for interchanging data between users, comprising initiation, data transmission and termination procedures. The session can be short (e.g. 2 packets), or long (e.g. one full page of text).

message: User data to be transferred in one or more packets in a session.

3.2 Symbols

For the purposes of this ETS, the following symbols apply:

E _o	reference field strength
R _o	Reference distance
D-M0, D-M1	names of signals defined in subclause 7.3

The symbols used in the clauses relating to transients and timings can be found in subclause 8.10.1.

3.3 Abbreviations

For the purposes of this ETS, the following abbreviations apply:

BS	Base Station
CRC	Cyclic Redundancy Code
dBc	decibels relative to the carrier power
emf	electromotive force
erp	effective radiated power
FEC	Forward Error Correction
FFSK	Fast Frequency Shift Keying
FSK	Frequency Shift Keying
GMSK	Gaussian Minimum Shift Keying
IF	Intermediate Frequency
LSB	Least Significant Bit
MSB	Most Significant Bit

MSK	Minimum Shift Keying
PLL	Phase Locked Loop
PSK	Phase Shift Keying
PSTN	Public Switched Telephone Network
rms	root mean square
RF	Radio Frequency
Rx	Receiver
sr	switching range
Tx	Transmitter
AR1, AR2	Categories of "alignment range" as defined in subclause 4.1

4 General

Equipment may be designed to fulfil the requirements of one or more ETSS.

In the case of combined full bandwidth analogue speech/full bandwidth digital equipment, if the analogue part of the equipment has already been type tested according to ETS 300 086 [2], only some additional measurements have to be performed; they shall ensure that the equipment fulfils the requirements of the following subclauses:

5.1.4 (8.5)	Adjacent channel power;
5.1.5 (8.6)	Spurious emissions;
5.1.7 (8.8)	Transmitter attack time;
5.1.8 (8.9)	Transmitter release time;
5.1.9 (8.10)	Transient behaviour of the transmitter;
5.2.1 (9.1)	Maximum usable sensitivity (data or messages, conducted);
5.2.2 (9.2)	Average usable sensitivity (data or messages, field strength) in the case of equipment having an integral antenna;
5.2.3 (9.4)	Error behaviour at high input levels;
5.2.4 (9.5)	Co-channel rejection;
5.2.5 (9.6)	Adjacent channel selectivity.

More precisely, the measurement of the spurious emissions (subclauses 5.1.5 and 8.6) should be performed when an equipment, previously type tested to ETS 300 086 [2], is being tested to this ETS with an add-on data unit. If the equipment has been originally combined for analogue and digital operation, the measurement of the spurious emissions need not to be performed again if the data port(s) (and the data circuits/modules) were active while making this measurement for the test to ETS 300 086 [2].

In the case where an equipment has already been type tested according to this ETS and is resubmitted with an add-on data unit using another type of modulation without affecting any other characteristic of the equipment, only some additional measurements should be performed; they shall ensure that the equipment fulfils the requirements of the following subclauses:

5.1.4 (8.5)	Adjacent channel power;
5.1.5 (8.6)	Spurious emissions;
5.2.1 (9.1)	Maximum usable sensitivity (data or messages, conducted);
5.2.2 (9.2)	Average usable sensitivity (data or messages, field strength) in the case of equipment having an integral antenna;
5.2.3 (9.4)	Error behaviour at high input levels;
5.2.4 (9.5)	Co-channel rejection;
5.2.5 (9.6)	Adjacent channel selectivity.

The foregoing seven measurements shall be performed on one piece of equipment tuned to a frequency in the centre of the band.

In the case where data is transmitted simultaneously together with analogue speech, the speech part of the equipment is tested according to ETS 300 086 [2], and it shall also be checked that the data does not cause the adjacent channel power and spurious emissions to fall outside the appropriate limits.

4.1 Presentation of equipment for testing purposes

Each equipment submitted for type testing shall fulfil the requirements of this ETS on all channels over which it is intended to operate.

To simplify and harmonise the type testing procedures between the different testing laboratories, measurements shall be performed, according to this ETS, on samples of equipment defined in subclauses 4.1.1 to 4.1.12.

These subclauses are intended to give confidence that the requirements set out in this ETS have been met without the necessity of performing measurements on all channels.

4.1.1 Choice of model for type testing

The manufacturer shall provide one or more production model(s) of the equipment, as appropriate, for type testing.

If type approval is given on the basis of tests on a preliminary model, then the corresponding production models shall be identical in all respects with the preliminary model tested.

In the case of hand portable equipment without a 50 Ω external antenna connector, see subclause 4.1.12.

4.1.2 Definitions of alignment range and switching range

The manufacturer shall, when submitting equipment for type testing, state the alignment ranges for the receiver and the transmitter.

The alignment range is defined as the frequency range over which the receiver and the transmitter can be programmed and/or realigned to operate, without any physical change of components other than programmable read only memories or crystals (for the receiver and the transmitter).

The manufacturer shall also state the switching range of the receiver and the transmitter (which may differ).

The switching range is the maximum frequency range over which the receiver or the transmitter can be operated without reprogramming or realignment.

For the purpose of all measurements, the receiver and transmitter shall be considered separately.

4.1.3 Definition of the categories of the alignment range (AR1 and AR2)

The alignment range falls into one of two categories. The first category corresponds to a limit of the alignment range, of the receiver and the transmitter, which is less than 10 % of the highest frequency of the alignment range for equipment operating on frequencies up to 500 MHz, or less than 5 % for equipment operating above 500 MHz. This category is defined as AR1.

The second category corresponds to an alignment range of the receiver and transmitter which is greater than 10 % of the highest frequency of the alignment range for equipment on frequencies up to 500 MHz, or greater than 5 % for equipment operating above 500 MHz. This category is defined as AR2.

4.1.4 Choice of frequencies

The frequencies for testing shall be chosen by the manufacturer in consultation with the appropriate Administration, in accordance with subclauses 4.1.5 to 4.1.11 (see also annex D). The manufacturer, when selecting the frequencies for testing, shall ensure that the frequencies chosen are within one or more of the national bands for which type approval is sought.

4.1.5 Testing of single channel equipment of category AR1

In the case of single channel equipment of the category AR1, one sample of the equipment shall be tested.

Full tests shall be carried out on a channel within 100 kHz of the centre frequency of the alignment range.

4.1.6 Testing of single channel equipment of category AR2

In the case of single channel equipment of the category AR2, three samples of the equipment shall be tested. Tests shall be carried out on a total of three channels.

The frequency of the channel of the first sample shall be within 100 kHz of the highest frequency of the alignment range.

The frequency of the channel of the second sample shall be within 100 kHz of the lowest frequency of the alignment range.

The frequency of the channel of the third sample shall be within 100 kHz of the centre frequency of the alignment range.

Full tests shall be carried out on all three channels.

4.1.7 Testing of two channel equipment of category AR1

In the case of two channel equipment of category AR1, one sample of the equipment shall be tested. Tests shall be carried out on the two channels.

The frequency of the upper channel shall be within 100 kHz of the highest frequency of the switching range.

The frequency of the lower channel shall be within 100 kHz of the lowest frequency of the switching range. In addition the average of the frequencies of the two channels shall be within 100 kHz of the centre frequency of the alignment range.

Full tests shall be carried out on the upper channel and limited tests on the lower channel.

4.1.8 Testing of two channel equipment of category AR2

In the case of two channel equipment of the category AR2, three samples of the equipment shall be tested. Tests shall be carried out on a total of four channels.

The highest frequency of the switching range of one sample shall be within 100 kHz of the centre frequency of the alignment range. The frequency of the upper channel shall be within 100 kHz of the highest frequency of the switching range and the frequency of the lower channel shall be within 100 kHz of the lowest frequency of the switching range.

Full tests shall be carried out on the upper channel and limited tests on the lower channel.

The frequency of one of the channels of the second sample shall be within 100 kHz of the highest frequency of the alignment range.

Full tests shall be carried out on this channel.

The frequency of one of the channels of the third sample shall be within 100 kHz of the lowest frequency of the alignment range.

Full tests shall be carried out on this channel.

4.1.9 Testing of multi-channel equipment (more than two channels) of category AR1

In the case of multi channel equipment of the category AR1, one sample of the equipment shall be tested.

The centre frequency of the switching range of the sample shall correspond to the centre frequency of the alignment range.

Full tests shall be carried out on a frequency within 100 kHz of the centre frequency of the switching range. Limited tests shall be carried out within 100 kHz of the lowest and also within 100 kHz of the highest frequency of the switching range.

4.1.10 Testing of multi channel equipment (more than two channels) of category AR2 (switching range less than the alignment range)

In the case of multi channel equipment of the category AR2, three samples of the equipment shall be tested. Tests shall be carried out on a total of five channels.

The centre frequency of the switching range of one sample shall be within 100 kHz of the centre frequency of the alignment range. The frequency of the upper channel shall be within 100 kHz of the highest frequency of the switching range and the frequency of the lower channel shall be within 100 kHz of the lowest frequency of the switching range.

Full tests shall be carried out on the centre channel and limited tests on the upper and lower channel.

The frequency of one of the channels of the second sample shall be within 100 kHz of the highest frequency of the alignment range.

Full tests shall be carried out on this channel.

The frequency of one of the channels of the third sample shall be within 100 kHz of the lowest frequency of the alignment range.

Full tests shall be carried out on this channel.

4.1.11 Testing of multi channel equipment (more than two channels) of category AR2 (switching range equals the alignment range)

In the case of multi channel equipment of the category AR2, one sample of the equipment shall be tested.

The centre frequency of the switching range of the sample shall correspond to the centre frequency of the alignment range.

Full tests shall be carried out on a frequency within 100 kHz of the centre frequency of the switching range and within 100 kHz of the lowest and also within 100 kHz of the highest frequency of the switching range.

4.1.12 Testing of equipment without an external 50 Ω RF connector

4.1.12.1 Equipment with an internal permanent or temporary antenna connector

The means to access and/or implement the internal permanent or temporary antenna connector shall be stated by the manufacturer with the aid of a diagram. The fact that use has been made of the internal antenna connection to facilitate measurements shall be recorded in the test report.

4.1.12.2 Equipment with a temporary antenna connector

The manufacturer, or his representative, may submit one set of equipment with the normal antenna connected, to enable the radiated measurements to be made. He shall attend the test laboratory at conclusion of the radiated measurements, to disconnect the antenna and fit the temporary connector.

The testing laboratory staff shall not connect or disconnect any temporary antenna connector.

Alternatively the manufacturer, or his representative, may submit two sets of equipment to the test laboratory, one fitted with a temporary antenna connector with the antenna disconnected and the other with the antenna connected. Each equipment shall be used for the appropriate tests.

4.2 Mechanical and electrical design

4.2.1 General

The equipment submitted for type testing by the manufacturer or his representative, shall be designed, constructed and manufactured in accordance with good engineering practice, and with the aim of minimising harmful interference to other equipment and services.

4.2.2 Controls

Those controls, which if maladjusted, might increase the interfering potentialities of the equipment shall not be accessible for adjustment by the user.

4.2.3 Transmitter shut-off facility

When a timer for an automatic shut-off facility is operative, at the moment of the time-out the transmitter shall automatically be switched off (the activation of the transmitter key shall reset the timer). A shut-off facility shall be inoperative for the duration of the type test measurements unless it has to remain operative to protect the equipment.

4.2.4 Marking

The marking shall be in accordance with EC Directives and/or CEPT decisions or recommendations as appropriate.

4.3 Testing using bit streams or messages

The manufacturer may elect to have the equipment tested using bit streams or messages. It should be noted that the methods of measurement using messages are usually more time consuming.

4.4 Interpretation of the measurement results

The interpretation of the results recorded in a test report for the measurements described in this ETS shall be as follows:

- a) the measured value related to the corresponding limit shall be used to decide whether an equipment meets the requirements of this ETS;
- b) the actual measurement uncertainty of the test laboratory carrying out the measurements, for each particular measurement, shall be included in the test report;
- c) the values of the actual measurement uncertainty shall be, for each measurement, equal to or lower than the figures given in clause 11 (absolute measurement uncertainties).

5 Technical characteristics

5.1 Transmitter parameter limits

5.1.1 Frequency error

For the definition and the method of measurement, see subclause 8.1.

The frequency error shall not exceed the values given in table 1, under normal and extreme test conditions, or in any intermediate set of conditions. However, for practical reasons the measurement shall be performed only at nominal and extreme test conditions as defined in subclause 8.1.

Table 1: Frequency error

Channel separation (kHz)	Frequency error limit (kHz)				
	below 47 MHz	47 to 137 MHz	above 137 to 300 MHz	above 300 to 500 MHz	above 500 to 1 000 MHz
20 & 25	± 0,60	± 1,35	± 2,00	± 2,00 (note)	± 2,50 (note)
12,5	± 0,60	± 1,00	± 1,00 (B) ± 1,50 (M)	± 1,00 (B) ± 1,50 (M)(note)	No value specified
<p>NOTE: For handportable stations having integral power supplies, these limits only apply to the reduced extreme temperature range 0°C to + 30°C.</p> <p>However for the full extreme temperature conditions (subclause 6.4.1), exceeding the reduced extreme temperature range above, the following frequency error limits apply:</p> <ul style="list-style-type: none"> - ± 2,50 kHz between 300 MHz and 500 MHz; - ± 3,00 kHz between 500 MHz and 1 000 MHz. <p>(B) base station (M) mobile station</p>					

5.1.2 Carrier power (conducted)

This measurement applies to all equipment covered by this ETS.

For the definition and the method of measurement, see subclause 8.2.

The carrier power (conducted) under the specified conditions of measurement (subclause 8.2.2) and at normal test conditions, shall be within ± 1,5 dB of the rated carrier power (conducted).

The carrier power (conducted) under extreme test conditions shall be within + 2,0 dB and - 3,0 dB of the rated output power.

5.1.3 Effective radiated power

This measurement applies only to equipment without a 50 Ω external antenna connector.

For the definition and the method of measurement, see subclause 8.3.

The measurement shall be carried out under normal test conditions only.

The effective radiated power under normal test conditions shall be within d_f from the rated effective radiated power.

The allowance for the characteristics of the equipment (± 1,5 dB) shall be combined with the actual measurement uncertainty in order to provide d_f , as follows:

$$d_f^2 = d_m^2 + d_e^2$$

where:

- d_m is the actual measurement uncertainty;
- d_e is the allowance for the equipment (1,5 dB);
- d_f is the final difference.

All values shall be expressed in linear terms.

In all cases the actual measurement uncertainty shall comply with clause 11.

Furthermore, the maximum effective radiated power shall not exceed the maximum value allowed by the Administrations.

Example of the calculation of d_f :

$$d_m = 6 \text{ dB (value acceptable, as indicated in the table of maximum uncertainties);}$$
$$= 3,98 \text{ in linear terms;}$$

$$d_e = 1,5 \text{ dB (fixed value for all equipment fulfilling the requirements of this ETS);}$$
$$= 1,41 \text{ in linear terms;}$$

$$d_f^2 = (3,98)^2 + (1,41)^2;$$

Therefore, $d_f = 4,22$ in linear terms, or 6,25 dB.

This calculation shows that in this case d_f is in excess by 0,25 dB compared to d_m , the actual measurement uncertainty (6 dB).

5.1.4 Adjacent channel power

For the definition and the method of measurement, see subclause 8.5.

For channel separations of 20 kHz and 25 kHz, the adjacent channel power shall not exceed a value of 70,0 dB below the carrier power (conducted) of the transmitter without any need to be below 0,2 μW (- 37 dBm). For a channel separation of 12,5 kHz, the adjacent channel power shall not exceed a value of 60,0 dB below the transmitter carrier power (conducted) without the need to be below 0,2 μW (- 37 dBm).

5.1.5 Spurious emissions

For the definition and the method of measurement, see subclause 8.6.

The power of any spurious emission shall not exceed the values given in tables 2 and 3.

Table 2: Conducted emissions

Frequency range	Tx operating	Tx standby
9 kHz to 1 GHz	0,25 μW (- 36 dBm)	2,0 nW (- 57 dBm)
above 1 GHz to 4 GHz, or above 1 GHz to 12,75 GHz (subclause 8.6.2)	1,00 μW (- 30 dBm)	20 nW (- 47 dBm)

Table 3: Radiated emissions

Frequency range	Tx operating	Tx standby
30 MHz to 1 GHz	0,25 μW (- 36 dBm)	2,0 nW (- 57 dBm)
above 1 GHz to 4 GHz	1,00 μW (- 30 dBm)	20 nW (- 47 dBm)

In the case of radiated measurements for handportable stations the following conditions apply:

- for equipment with an internal integral antenna, the normal antenna shall remain connected;
- for equipment with an external antenna socket, an artificial load shall be connected to the socket for the test.

5.1.6 Intermodulation attenuation

This requirement applies only to transmitters to be used in base stations. For the definition and the method of measurement, see subclause 8.7.

Two classes of transmitter intermodulation attenuation are defined, the equipment shall fulfil one of the requirements:

- in general the intermodulation attenuation ratio shall be at least 40,0 dB for any intermodulation component;
- for base station equipment to be used in special service conditions (e.g. at sites where more than one transmitter will be in service) or when the regulatory authority makes it a condition of the licence, the intermodulation attenuation ratio shall be at least 70,0 dB for any intermodulation component. In the case where the performance is achieved by additional internal or external isolating devices (such as circulators) they shall be supplied at the time of type testing and shall be used for the measurements.

5.1.7 Transmitter attack time

For the definitions and the method of measurement, see subclauses 8.8 and 8.10.1 and figures 12 and 13.

The transmitter attack time shall not exceed 25 ms ($t_{am} \leq t_{al}$).

5.1.8 Transmitter release time

For the definitions and the method of measurement, see subclauses 8.9 and 8.10.1 and figure 14.

The transmitter release time shall not exceed 20 ms ($t_{rm} \leq t_{rl}$).

5.1.9 Transient behaviour of the transmitter

For the definition and the method of measurement, see subclause 8.10 and figures 12, 13 and 14.

5.1.9.1 Time domain analysis of power and frequency

The plots of carrier power (conducted) and carrier frequency as a function of time, covering in an appropriate way the transients, shall be included in the test report.

At any time when the carrier power is above $P_c - 30$ dB, the carrier frequency shall remain within half a channel separation (df_c) from the steady carrier frequency (F_c).

The slopes of the plots "power as a function of time" corresponding to both attack and release times, shall be such that:

- $t_p \geq 0,20$ ms and $t_d \geq 0,20$ ms, for attack and release time;
- between the $P_c - 30$ dB point and the $P_c - 6$ dB point, both in the case of attack and release time, the sign of the slope shall not change.

5.1.9.2 Adjacent channel transient power

The transient power, in the adjacent channels shall not exceed a value of:

- 60,0 dB below the carrier power (conducted) of the transmitter in decibels relative to the carrier power (dBc) without the need to be below 2 μ W (- 27,0 dBm), for channel separations of 20 kHz and 25 kHz;
- 50,0 dB below the carrier power (conducted) of the transmitter (in dBc) without the need to be below 2 μ W (- 27,0 dBm), for a channel separation of 12,5 kHz.

5.2 Receiver parameter limits

5.2.1 Maximum usable sensitivity (data or messages, conducted)

This measurement applies to all equipment covered by this ETS.

For the definition and the method of measurement, see subclause 9.1.

The maximum usable sensitivity shall not exceed an electromotive force (emf) of + 3,0 dB μ V under normal test conditions, and an emf of + 9,0 dB μ V under extreme test conditions.

5.2.2 Average usable sensitivity (data or messages, field strength)

This measurement applies only to equipment without a 50 Ω external antenna connector.

For the definition and the method of measurement see ETS 300 390 [3], subclause 9.1 (see also subclause 9.2 of this ETS).

For the categories of equipment and the average usable sensitivity limits, see ETS 300 390 [3], subclause 5.2.1.

5.2.3 Error behaviour at high input levels

For the definition and the method of measurement, see subclause 9.4

The bit error ratio (continuous bit streams) shall not exceed 10^{-4} .

The number of messages not correctly received (lost or corrupted) shall not exceed 1.

5.2.4 Co-channel rejection

For the definition and the method of measurement, see subclause 9.5.

The value of the co-channel rejection ratio, expressed in dB, at the signal displacements given in the method of measurement, shall be:

- between - 8,0 dB and 0 dB, for channel separations of 20 kHz and 25 kHz;
- between - 12,0 dB and 0 dB, for channel separations of 12,5 kHz.

Any positive value is also acceptable.

5.2.5 Adjacent channel selectivity

For the definition and the method of measurement, see subclause 9.6.

The adjacent channel selectivity for different channel separations shall not be less than the values given in table 4.

Table 4: Adjacent channel selectivity

	Channel separation	
	12,5 kHz	20/25 kHz
normal test conditions	60,0 dB	70,0 dB
extreme test conditions	50,0 dB	60,0 dB

5.2.6 Spurious response rejection

For the definition and the method of measurement, see subclause 9.7.

At any frequency separated from the nominal frequency of the receiver by two channels or more, the spurious response rejection shall not be less than 70,0 dB.

5.2.7 Intermodulation response rejection

For the definition and the method of measurement, see subclause 9.8.

The intermodulation response rejection ratio shall not be less than 70,0 dB for base station equipment and 65,0 dB for mobile and handportable equipment.

5.2.8 Blocking or desensitisation

For the definition and the method of measurement, see subclause 9.9.

The blocking ratio for any frequency within the specified ranges shall not be less than 84,0 dB, except at frequencies on which spurious responses are found (subclause 9.7).

5.2.9 Spurious radiations

For the definition and the method of measurement, see subclause 9.10.

The power of any spurious radiation shall not exceed the values given in tables 5 and 6.

Table 5: Conducted components

Frequency range	Limit
9 kHz to 1 GHz	2,0 nW (- 57 dBm)
above 1 GHz to 4 GHz, or above 1 GHz to 12,75 GHz (subclause 9.10.2)	20,0 nW (- 47 dBm)

Table 6: Radiated components

Frequency range	Limit
30 MHz to 1 GHz	2,0 nW (- 57 dBm)
above 1 GHz to 12,75 GHz	20,0 nW (- 47 dBm)

In the case of radiated measurements for handportable stations the following conditions apply:

- for equipment having an external antenna socket, an artificial load shall be connected to the socket during the test;
- for equipment having no external antenna socket, the normal integral antenna shall be used.

5.3 Duplex operation - receiver limits

5.3.1 Receiver desensitisation and maximum usable sensitivity (with simultaneous transmission and reception)

For the definition and the method of measurement, see subclause 10.1.

The desensitisation shall not exceed 3,0 dB and the limit of maximum usable sensitivity under normal test conditions shall be met (subclause 5.2.1).

5.3.2 Receiver spurious response rejection (with simultaneous transmission and reception)

For the definition and the method of measurement, see subclause 10.2.

At any frequency separated from the nominal frequency of the receiver by two channels or more, the spurious response rejection ratio shall be greater than 67,0 dB.

6 Test conditions, power sources and ambient temperatures

6.1 Normal and extreme test conditions

Type testing shall be made under normal test conditions, and also, where stated, under extreme test conditions.

The test conditions and procedures shall be as specified in subclauses 6.2 to 6.5.

6.2 Test power source

During type testing the power source of the equipment shall be replaced by a test power source, capable of producing normal and extreme test voltages as specified in subclauses 6.3.2 and 6.4.2. The internal impedance of the test power source shall be low enough for its effect on the test results to be negligible. For the purpose of tests, the voltage of the power source shall be measured at the input terminals of the equipment.

If the equipment is provided with a permanently connected power cable, the test voltage shall be that measured at the point of connection of the power cable to the equipment.

For battery operated equipment the battery shall be removed and the test power source shall be applied as close to the battery terminals as practicable.

During tests the power source voltages shall be maintained within a tolerance $\pm 1\%$ relative to the voltage at the beginning of each test. The value of this tolerance is critical for power measurements. Using a smaller tolerance provides a better uncertainty value for these measurements.

6.3 Normal test conditions

6.3.1 Normal temperature and humidity

The normal temperature and humidity conditions for tests shall be any convenient combination of temperature and humidity within the following ranges:

- temperature: + 15 °C to + 35 °C;
- relative humidity: 20 % to 75 %.

When it is impracticable to carry out the tests under these conditions, a note to this effect, stating the ambient temperature and relative humidity during the tests, shall be added to the test report.

6.3.2 Normal test power source

6.3.2.1 Mains voltage

The normal test voltage for equipment to be connected to the mains shall be the nominal mains voltage. For the purpose of this ETS, the nominal voltage shall be the declared voltage or any of the declared voltages for which the equipment was designed.

The frequency of the test power source corresponding to the ac mains shall be between 49 Hz and 51 Hz.

6.3.2.2 Regulated lead-acid battery power sources used on vehicles

When the radio equipment is intended for operation from the usual types of regulated lead-acid battery power source used on vehicles, the normal test voltage shall be 1,1 times the nominal voltage of the battery (for nominal voltages of 6 V and 12 V, these are 6,6 V and 13,2 V respectively).

6.3.2.3 Other power sources

For operation from other power sources or types of battery (primary or secondary), the normal test voltage shall be that declared by the equipment manufacturer.

6.4 Extreme test conditions

6.4.1 Extreme temperatures

For tests at extreme temperatures, measurements shall be made in accordance with the procedures specified in subclause 6.5, at the upper and lower temperatures of the following range:

- - 20°C to + 55°C.

For the purpose of the note to table 1, subclause 5.1.1, an additional reduced extreme temperature range of 0 °C to + 30 °C shall be used when appropriate.

Type test reports shall state the temperature range used.

6.4.2 Extreme test source voltages

6.4.2.1 Mains voltage

The extreme test voltage for equipment to be connected to an ac mains source shall be the nominal mains voltage $\pm 10\%$.

6.4.2.2 Regulated lead-acid battery power sources on vehicles

When the radio equipment is intended for operation from the usual type of regulated lead-acid battery power sources used on vehicles, the extreme test voltages shall be 1,3 and 0,9 times the nominal voltage of the battery (for a nominal voltage of 6 V, these are 7,8 V and 5,4 V respectively and for a nominal voltage of 12 V, these are 15,6 V and 10,8 V respectively).

6.4.2.3 Power sources using other types of batteries

The lower extreme test voltage for equipment with power sources using batteries shall be as follows:

- for the Leclanché or the lithium type of battery:
 - 0,85 times the nominal voltage of the battery;
- for the mercury type or nickel-cadmium type of battery:
 - 0,9 times the nominal voltage of the battery.

No upper extreme test voltages apply.

In the case where no upper extreme test voltage above the nominal voltage is applicable, the corresponding four extreme test conditions are:

- V_{\min} / T_{\min} , V_{\min} / T_{\max} ;
- $(V_{\max} = \text{nominal}) / T_{\min}$, $(V_{\max} = \text{nominal}) / T_{\max}$.

6.4.2.4 Other power sources

For equipment using other power sources, or capable of being operated from a variety of power sources, the extreme test voltages shall be those agreed between the equipment manufacturer and the testing laboratory and shall be recorded in the test report.

6.5 Procedure for tests at extreme temperatures

Before measurements are made the equipment shall have reached thermal balance in the test chamber. The equipment shall be switched off during the temperature stabilising period.

In the case of equipment containing temperature stabilisation circuits designed to operate continuously, the temperature stabilisation circuits may be switched on for 15 minutes after thermal balance has been

obtained, and the equipment shall then meet the specified requirements. For such equipment the manufacturer shall provide for the power source circuit feeding the crystal oven, to be independent of the power source for the rest of the equipment.

If the thermal balance is not checked by measurements, a temperature stabilising period of at least one hour, or a longer period of time as may be decided by the testing laboratory, shall be allowed. The sequence of measurements shall be chosen, and the humidity content in the test chamber shall be controlled so that excessive condensation does not occur.

6.5.1 Procedure for equipment designed for continuous operation

If the manufacturer states that the equipment is designed for continuous operation, the test procedure shall be as follows.

Before tests at the upper extreme temperature the equipment shall be placed in the test chamber and left until thermal balance is attained. The equipment shall then be switched on in the transmit condition for a period of half an hour after which the equipment shall meet the specified requirements.

Before tests at the lower extreme temperature the equipment shall be left in the test chamber until thermal balance is attained, then switched to the standby or receive condition for a period of one minute after which the equipment shall meet the specified requirements.

6.5.2 Procedure for equipment designed for intermittent operation

If the manufacturer states that the equipment is designed for intermittent operation, the test procedure shall be as follows.

Before tests at the upper extreme temperature the equipment shall be placed in the test chamber and left until thermal balance is attained. The equipment shall then be switched on for one minute in the transmit condition, followed by four minutes in the receive condition, after which the equipment shall meet the specified requirements.

Before tests at the lower extreme temperature the equipment shall be left in the test chamber until thermal balance is attained, then switched to the standby or receive condition for one minute after which the equipment shall meet the specified requirements.

7 General conditions

7.1 Arrangements for test signals applied to the receiver input

Sources of test signals for application to the receiver input shall be connected in such a way that the source impedance presented to the receiver input is 50 Ω (non-reactive, subclause 7.6).

This requirement shall be met irrespective of whether one or more signals using a combining network are applied to the receiver simultaneously.

The levels of the test signals at the receiver input terminals (RF socket) shall be expressed in terms of emf.

The effects of any intermodulation products and noise produced in the test signal sources shall be negligible.

7.2 Receiver mute or squelch facility

If the receiver is equipped with a mute or squelch circuit, this shall be made inoperative for the duration of the type testing.

7.3 Normal test signals (wanted and unwanted signals)

When the equipment is designed to transmit continuous bit streams (e.g. data, facsimile, image transmission, digital speech) the normal test signal shall be as follows:

- signal D-M0, consisting of an infinite series of 0 bits;
- signal D-M1, consisting of an infinite series of 1 bits;
- signal D-M2, consisting of a pseudorandom bit sequence of at least 511 bits according to CCITT Recommendation O.153 [5];
- signal D-M2', this is the same type as D-M2, but the pseudorandom bit sequence is independent of D-M2 (perhaps identical with D-M2 but started at another point of time);
- signal A-M3, consisting of an RF signal, modulated by an audio frequency signal of 400 Hz with a deviation of 12 % of the channel separation. This signal is used as an unwanted signal.

Applying an infinite series of 0 bits or 1 bits does not normally produce the typical bandwidth. Signal D-M2 is designed to produce a good approximation of the typical bandwidth.

Information concerning technical characteristics of modulation, coding and format is given in annex E.

If the transmission of a continuous bit stream is not possible, the normal test signal shall be trains of correctly coded bits or messages. This signal shall be that, as agreed between the manufacturer and the testing laboratory, which produces the greatest radio frequency occupied bandwidth. Details of this test signal shall be included in the test report.

In this case, the encoder, which is associated with the transmitter, shall be capable of supplying the normal test signal. The resulting modulation is called the normal test modulation. If possible this should be continuous modulation for the duration of the measurements.

For measurements using the up-down method (note) it shall be possible to trigger single test signals "D-M3" either manually or by an automatic testing system.

The test signal D-M4 consists of correctly coded signals, messages transmitted sequentially, one by one, without gaps between them. This transmission is necessary for measurements such as adjacent channel power (subclauses 5.1.4 and 8.5) and spurious emissions (subclauses 5.1.5 and 8.6).

The signal A-M3 is used as an unwanted signal for measurements such as co-channel rejection (subclauses 5.2.4 and 9.5) and adjacent channel selectivity (subclauses 5.2.5 and 9.6).

Details of D-M3 and D-M4 shall be recorded in the test report.

NOTE: A method of measurement implementing the "up-down method" can be found in subclause 9.1.3 (method of measurement of the maximum usable sensitivity using messages).

7.4 Encoder for receiver measurements

Whenever needed and in order to facilitate measurements on the receiver, an encoder for the data system shall accompany the model submitted, together with details of the normal modulation process. The encoder is used to modulate a signal generator for use as a test signal source.

In the case of equipment unable to operate with continuous bit streams, the encoder shall be capable of operation in a repetitive mode, with intervals between each message that are not less than the reset time of the receiver.

Complete details of all codes and code format(s) used shall be given.

7.5 Transceiver data interface

Equipment that does not integrate the keyboard and display used for normal operation shall provide a V.24/V.28 interface (preferably) or other suitable interfaces.

In the case where the equipment uses a proprietary interface, appropriate means and documentation allowing for the equipment to be tested shall be provided in view of type testing.

Variation in the level of the input signals, within the specified limits for that interface, shall have no measurable influence on the characteristics of the signals on the radio path.

7.6 Impedance

In this ETS the term "50 Ω " is used for a 50 Ω non-reactive impedance.

7.7 Artificial antenna

Tests shall be carried out using an artificial antenna which shall be a substantially non-reactive non-radiating load of 50 Ω connected to the antenna connector.

NOTE: Some of the methods of measurement described in this ETS for the transmitters, allow for two or more different test set ups in order to perform that measurement, all supposed to provide equivalent results. The corresponding figures illustrate therefore one particular test set up, and are given as examples. In many of those figures, power attenuators have been shown (and not "artificial antennas" as defined here above).

Such (power) attenuators shall provide a substantially non-reactive non-radiating load of 50 Ω to the antenna connector.

7.8 Tests of equipment with a duplex filter

If the equipment is provided with a built-in duplex filter or a separate associated filter, the requirements of this ETS shall be met when the measurements are carried out using the antenna connector of the filter.

7.9 Facilities for access

7.9.1 Analogue access

In order to simplify the measurements in subclauses 9.2 and 9.7, temporary access to a point where the amplitude of the analogue output of the RF part can be measured should be provided, e.g. Intermediate Frequency (IF) output or the demodulated subcarrier point may be provided for the equipment to be tested. This access can be used to determine or verify the frequency where a spurious response is expected.

7.9.2 Test points for bit stream measurements

It is recognised that it is not always possible to measure the air interface bit stream. The manufacturer shall define the test points at which the equipment shall be tested in order to make the measurements on bit streams according to clauses 8, 9 and 10.

Figure 1 is presented as an example for clarification only.

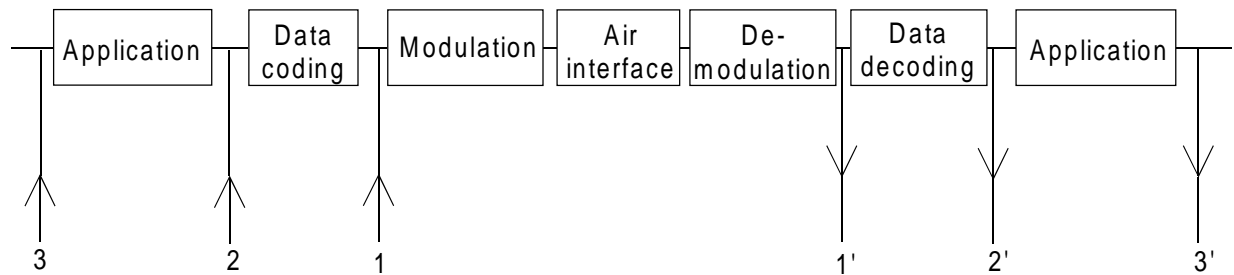

Figure 1: Test points for bit stream measurements

It should be noted that the closer the test access point is located to the air interface (figure 1), a fewer number of variants may have to be type tested because the measurement is less application dependent.

The tests shall be performed by use of corresponding test points (1,1' or 2,2' or 3,3').

The test points used shall be recorded in the test report.

7.9.3 Coupling arrangements

If the equipment does not have an external antenna connector, arrangements shall be made by the manufacturer to couple the unit to be tested to the test equipment by a method which does not affect the radiated field (e.g. acoustic, ultra sonic or optic) and according to subclauses 7.9.3.1 and 7.9.3.2.

These arrangements are required for testing integral antenna equipment in accordance with ETS 300 390 [3].

7.9.3.1 Arrangements for measurements with continuous bit streams

For the measurements of the receiver on a test site, arrangements to couple the unit to be tested to the bit error ratio measuring device shall be available (subclause 7.9.2).

Furthermore, the manufacturer may also provide another facility to give access to the analogue information (subclause 7.9.1).

7.9.3.2 Arrangements for measurements with messages

For the measurement of the receiver on a test site, arrangements to couple the unit to be tested to the error observation device (or to an operator) shall be available.

Furthermore, the manufacturer shall also provide another facility to give access to the analogue information (subclause 7.9.1).

7.10 Test site and general arrangements for measurements involving the use of radiated fields

For guidance see annex A: descriptions of the radiated measurement arrangements are included in this annex.

7.11 Modes of operation of the transmitter

For the purpose of the measurements according to this ETS, there should preferably be a facility to operate the transmitter unmodulated.

The method of obtaining an unmodulated carrier or special types of modulation patterns may also be decided by agreement between the manufacturer and the test laboratory. It shall be described in the test report. It may involve suitable temporary internal modifications of the equipment under test. For instance in the case of direct Frequency Shift Keying (FSK), a means to continuously transmit a sequence D-M0 containing only "zeros" and a sequence D-M1 containing only "ones" is desirable.

8 Methods of measurement for transmitter parameters

8.1 Frequency error

This measurement is made if the equipment is capable of producing an unmodulated carrier. Otherwise the adjacent channel power shall also be measured under extreme test conditions and the limits given in subclause 5.1.4 shall be met.

8.1.1 Definition

The frequency error of the transmitter is the difference between the measured carrier frequency in the absence of modulation and the nominal frequency of the transmitter.

8.1.2 Method of measurement

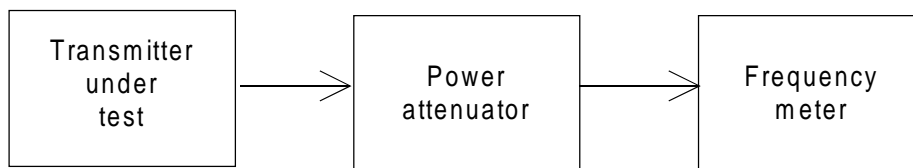

Figure 2: Measurement arrangement

The equipment shall be connected to the artificial antenna (subclause 7.7).

The carrier frequency shall be measured in the absence of modulation. The measurement shall be made under normal test conditions (subclause 6.3) and extreme test conditions (subclauses 6.4.1 and 6.4.2 applied simultaneously).

The limit(s) corresponding to this parameter can be found in subclause 5.1.1.

8.2 Carrier power (conducted)

It is assumed that the appropriate Administration will state the maximum transmitter output power/effective radiated power (as a condition for issuing licences).

If the equipment is designed to operate with different carrier powers, the rated power for each level, or range of levels, shall be declared by the manufacturer. The power adjustment control shall not be accessible to the user.

The requirements of this ETS shall be met for all power levels at which the transmitter is intended to operate. For practical reasons, measurements shall be performed only at the lowest and highest power level at which the transmitter is intended to operate.

8.2.1 Definitions

The transmitter carrier power (conducted) is the mean power delivered to the artificial antenna during a radio frequency cycle.

The rated output power is the carrier power (conducted) of the equipment declared by the manufacturer.

8.2.2 Method of measurement

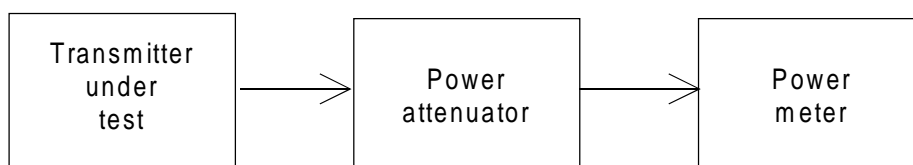

Figure 3: Measurement arrangement

The measurement shall be performed preferably in the absence of modulation.

When it is not possible to measure it in the absence of modulation, this fact shall be stated in the test report (subclause 7.11).

The transmitter shall be connected to an artificial antenna (subclause 7.7), and the power delivered to this artificial antenna shall be measured.

The measurement shall be made under normal test conditions (subclause 6.3) and extreme test conditions (subclauses 6.4.1 and 6.4.2 applied simultaneously).

The limit(s) corresponding to this parameter can be found in subclause 5.1.2 .

8.3 Effective radiated power (field strength)

This measurement applies only to equipment without an external antenna connector.

If the equipment is designed to operate with different carrier powers, the rated power for each level, or range of levels, shall be declared by the manufacturer. The power adjustment control shall not be accessible to the user.

The requirements of this ETS shall be met for all power levels at which the transmitter is intended to operate. For practical reasons measurements shall be performed only at the lowest and highest power level at which the transmitter is intended to operate.

8.3.1 Definition

The effective radiated power is the power radiated in the direction of the maximum field strength under specified conditions of measurements.

The rated effective radiated power is the effective radiated power of the equipment as declared by the manufacturer.

8.3.2 Method of measurement

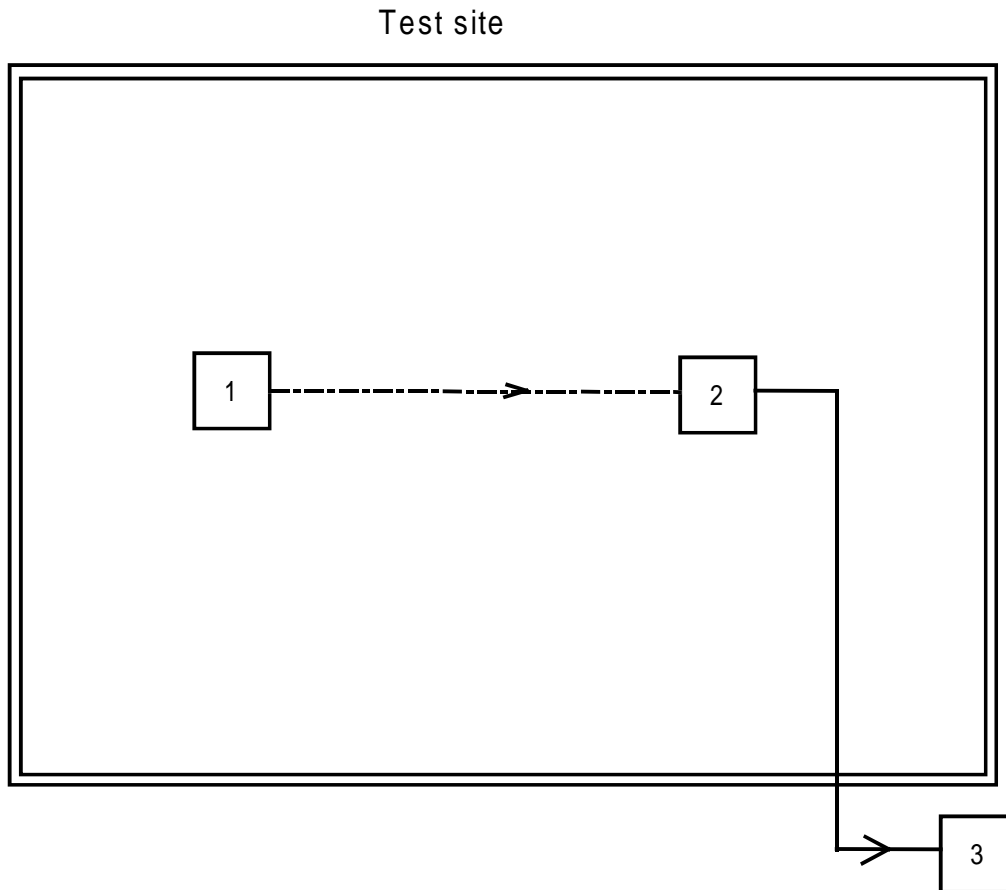

- 1) Transmitter under test
- 2) Test antenna
- 3) Spectrum analyzer or selective voltmeter (test receiver)

Figure 4: Measurement arrangement

The measurement shall be performed preferably in the absence of modulation.

When it is not possible to measure it in the absence of modulation this fact shall be stated in the test report (subclause 7.11).

The procedure shall be as follows:

- a) a test site, selected from annex A, which fulfils the requirements of the specified frequency range of this measurement shall be used. The test antenna shall be orientated initially for vertical polarisation unless otherwise stated;

The transmitter under test shall be placed at the specified height on a non-conducting support in the position closest to normal use as declared by the manufacturer. This position shall be recorded in the test report.

- b) the spectrum analyzer or selective voltmeter shall be tuned to the transmitter carrier frequency. The test antenna shall be raised or lowered through the specified height range until the maximum signal level is detected on the spectrum analyzer or selective voltmeter;

The test antenna need not be raised or lowered if the measurement is carried out on a test site according to clause A.3 (i.e. an anechoic chamber).

- c) the transmitter shall be rotated through 360° about a vertical axis until a higher maximum signal is received;

- d) the test antenna shall be raised or lowered again through the specified height range until a maximum is obtained. This level shall be recorded. (This maximum may be a lower value than the value obtainable at heights outside the specified limits);

The test antenna need not be raised or lowered if the measurement is carried out on a test site according to clause A.3 (i.e. an anechoic chamber).

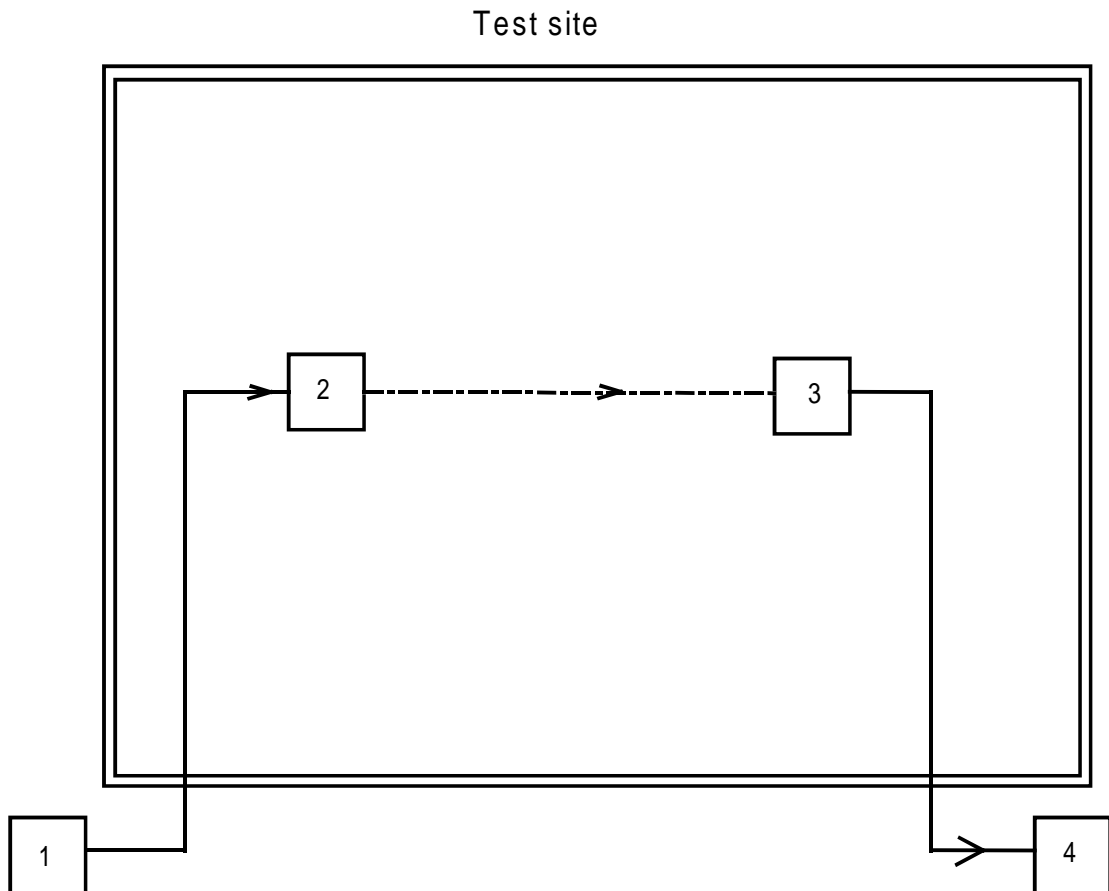

- 1) Signal generator
- 2) Substitution antenna
- 3) Test antenna
- 4) Spectrum analyzer or selective voltmeter (test receiver)

Figure 5: Measurement arrangement

- e) using the measurement arrangement of figure 5, the substitution antenna (subclause A.1.3) shall replace the transmitter antenna in the same position and in vertical polarisation. The frequency of the signal generator shall be adjusted to the transmitter carrier frequency. The test antenna shall be raised or lowered as necessary to ensure that the maximum signal is still received;

The test antenna need not be raised or lowered if the measurement is carried out on a test site according to clause A.3 (i.e. an anechoic chamber).

The input signal to the substitution antenna shall be adjusted in level until an equal or a known related level to that detected from the transmitter is obtained in the test receiver. The maximum carrier radiated power is equal to the power supplied by the signal generator, increased by the known relationship if necessary and after corrections due to the gain of the substitution antenna and the cable loss between the signal generator and the substitution antenna.

- f) steps b) to e) above shall be repeated with the test antenna and the substitution antenna orientated in horizontal polarisation.

The measure of the effective radiated power is the larger of the two power levels recorded at the input to the substitution antenna, corrected for the gain of the antenna if necessary.

The limit(s) corresponding to this parameter can be found in subclause 5.1.3 .

8.4 Maximum permissible frequency deviation

This measurement is only performed with equipment using subcarrier FSK-modulation.

It is more particularly suitable for use in the case of field measurements. No limits are given for this parameter.

8.4.1 Definition

The maximum permissible frequency deviation is the maximum value of the frequency deviation, measured according to this ETS.

8.4.2 Method of measurement

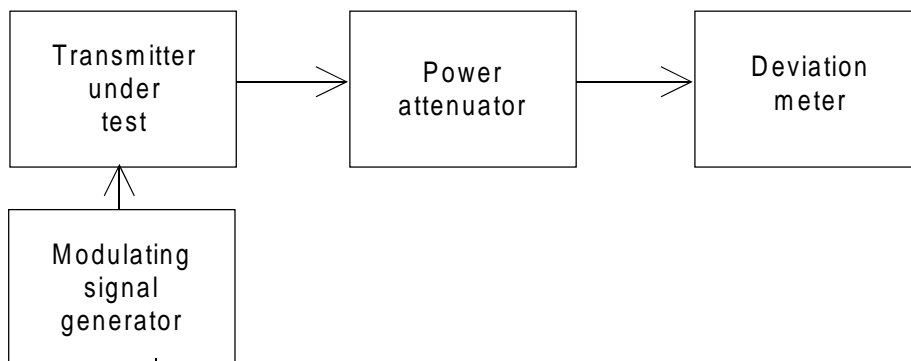

Figure 6: Measurement arrangement

The frequency deviation shall be measured at the output of the transmitter connected to an artificial antenna (subclause 7.7), by means of a deviation meter capable of measuring the maximum deviation, including that due to any harmonics and intermodulation products which may be generated in the transmitter.

Two types of measurement shall be carried out:

- one with the test signal D-M0, producing a frequency deviation of F_0 ;
- the other with the test signal D-M1, producing a frequency deviation of F_1 .

8.5 Adjacent channel power

8.5.1 Definition

The adjacent channel power is that part of the total power output of a transmitter under defined conditions of modulation, which falls within a specified passband centred on the nominal frequency of either of the adjacent channels. This power is the sum of the mean power produced by the modulation, hum and noise of the transmitter.

8.5.2 Method of measurement

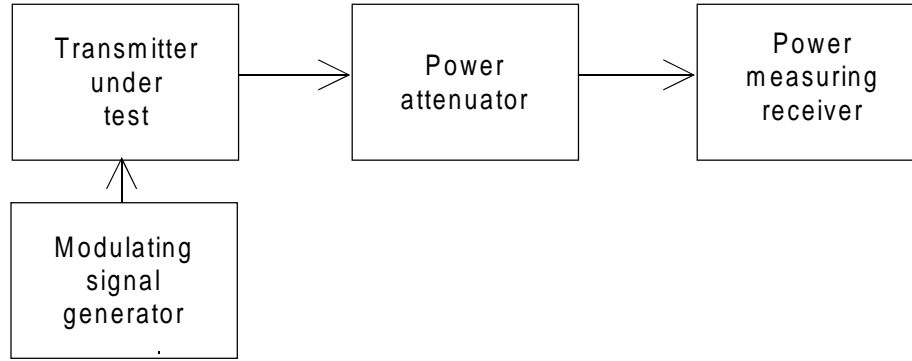

Figure 7: Measurement arrangement

The adjacent channel power may be measured, as follows, with a power measuring receiver which conforms to annex B (referred to in this subclause as the "receiver"):

- a) the transmitter shall be operated at the carrier power determined in subclause 8.2 under normal test conditions (subclause 6.3). The output of the transmitter shall be linked to the input of the "receiver" by a connecting device such that the impedance presented to the transmitter is 50 Ω and the level at the "receiver input" is appropriate;
- b) with the transmitter unmodulated, the tuning of the "receiver" shall be adjusted so that a maximum response is obtained. This is the 0 dB response point. The "receiver" attenuator setting and the reading of the meter shall be recorded. If an unmodulated carrier can not be obtained, then the measurement shall be made with the transmitter modulated with the normal test signal D-M2 or D-M4 as appropriate, according to subclause 7.3, in which case this fact shall be recorded in the test report;
- c) the frequency of the "receiver" shall be adjusted above the carrier so that the "receiver" - 6 dB response nearest to the transmitter carrier frequency is located at a displacement from the nominal carrier frequency as given in table 7;

Table 7: Frequency displacement

Channel separation (kHz)	Specified necessary bandwidth (kHz)	Displacement from the - 6 dB point (kHz)
12,5	8,5	8,25
20	14	13
25	16	17

- d) the transmitter shall be modulated by a normal test signal D-M2 or D-M4 as appropriate, according to subclause 7.3;
- e) the "receiver" variable attenuator shall be adjusted to obtain the same meter reading as in step b), or a known relation to it;
- f) the ratio of the adjacent channel power to the carrier power is the difference between the attenuator settings in steps b) and e), corrected for any differences in the reading of the meter;
- g) the measurement shall be repeated with the frequency of the "receiver" adjusted below the carrier so that the "receiver" - 6 dB response nearest to the transmitter carrier frequency is located at a displacement from the nominal carrier frequency as given in table 7;
- h) when it is not possible to perform the measurement of frequency error in the absence of modulation (subclause 8.1), this measurement shall be repeated under extreme test conditions (subclauses 6.4.1 and 6.4.2 applied simultaneously).

The limit(s) corresponding to this parameter can be found in subclause 5.1.4 .

8.6 Spurious emissions

8.6.1 Definition

Spurious emissions are emissions at frequencies other than those of the carrier and sidebands associated with normal modulation.

The level of spurious emissions shall be measured by:

either

- a) their power level in a specified load (conducted spurious emission); and
- b) their effective radiated power when radiated by the cabinet and structure of the equipment (cabinet radiation);

or

- c) their effective radiated power when radiated by the cabinet and by the integral antenna, in the case of hand portable equipment fitted with such an antenna and no external RF connector.

8.6.2 Method of measuring the power level

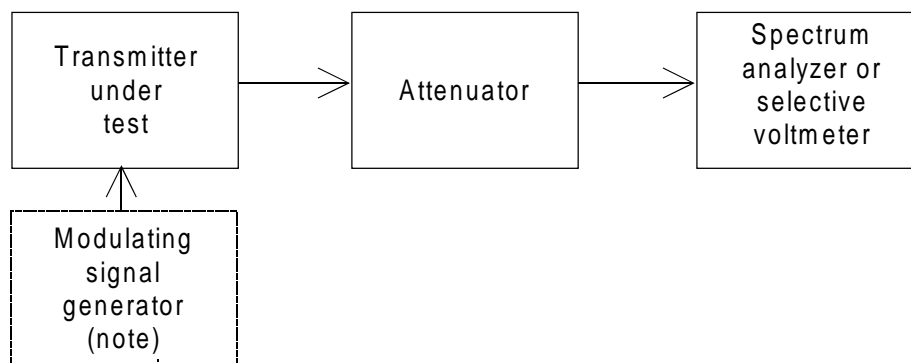

NOTE : Used only if it is not possible to perform the measurement with the transmitter unmodulated.

Figure 8: Measurement arrangement

This method applies only to equipment having an external connector.

Spurious emissions shall be measured as the power level of any discrete signal (excluding the wanted signal) delivered into a 50 Ω load. This may be done by connecting the transmitter output through an attenuator to a spectrum analyzer (clause B.2) or selective voltmeter, or by monitoring the relative levels of the spurious signals delivered to an artificial antenna (subclause 7.7).

If possible, the measurement shall be made with the transmitter unmodulated. If this is not possible, the transmitter shall be modulated by the normal test signal D-M2 or D-M4 as appropriate (subclause 7.3). If possible the modulation should be continuous for the duration of the measurement.

The resolution bandwidth of the measuring instrument shall be the smallest bandwidth available which is greater than the spectral width of the spurious component being measured. This shall be considered to be achieved when the next highest bandwidth causes less than 1 dB increase in amplitude.

The conditions used in the relevant measurements shall be recorded in the test report.

The measurements shall be made, for equipment operating on frequencies not exceeding 470 MHz, in the frequency range 9 kHz - 4 GHz, and for equipment operating on frequencies above 470 MHz, additionally in the frequency range 4 GHz - 12,75 GHz, except for the channel on which the transmitter is intended to operate, and its adjacent channels.

The measurement shall be repeated with the transmitter in the "stand-by" position.

The limit(s) corresponding to this parameter can be found in subclause 5.1.5.

8.6.3 Method of measuring the effective radiated power

Test site

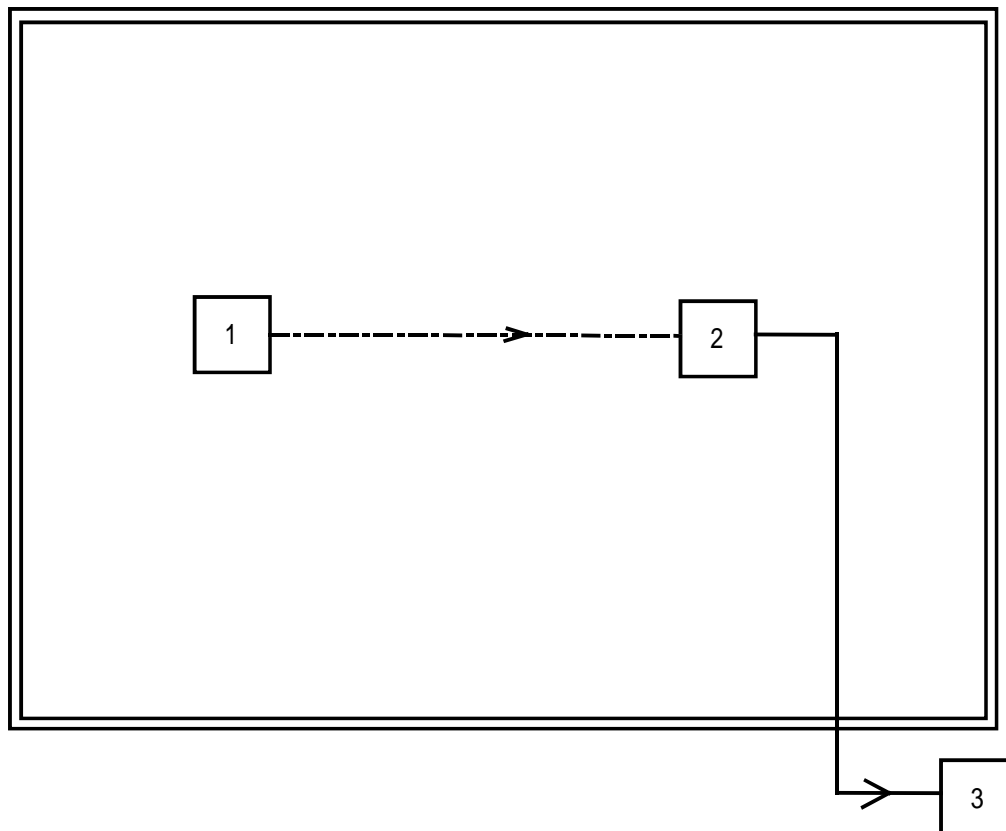

- 1) Transmitter under test
- 2) Test antenna
- 3) Spectrum analyzer or selective voltmeter (test receiver)

Figure 9: Measurement arrangement

The measurement procedure shall be as follows:

- a) on a test site, fulfilling the requirements of clause A.2, the sample shall be placed at the specified height on the support. The transmitter shall be operated at the carrier power as specified under subclause 8.2, delivered to:
 - an artificial antenna (subclause 7.7) for equipment having an external antenna connector (subclause 8.6.1, b)); or
 - to the integral antenna (subclause 8.6.1, c)).
- b) if possible, the measurement shall be made with the transmitter unmodulated. If this is not possible, the transmitter shall be modulated by the normal test signal D-M2 or D-M4 as appropriate (subclause 7.3). If possible the modulation should be continuous for the duration of the measurement;

The resolution bandwidth of the measuring instrument shall be the smallest bandwidth available which is greater than the spectral width of the spurious component being measured. this shall be considered to be achieved when the next highest bandwidth causes less than 1 dB increase in amplitude.

The conditions used in the relevant measurements shall be reported in the test report.

- c) the radiation of any spurious components shall be detected by the test antenna and receiver, over the frequency range 30 MHz - 4 GHz, except for the channel on which the transmitter is intended to operate and its adjacent channels;

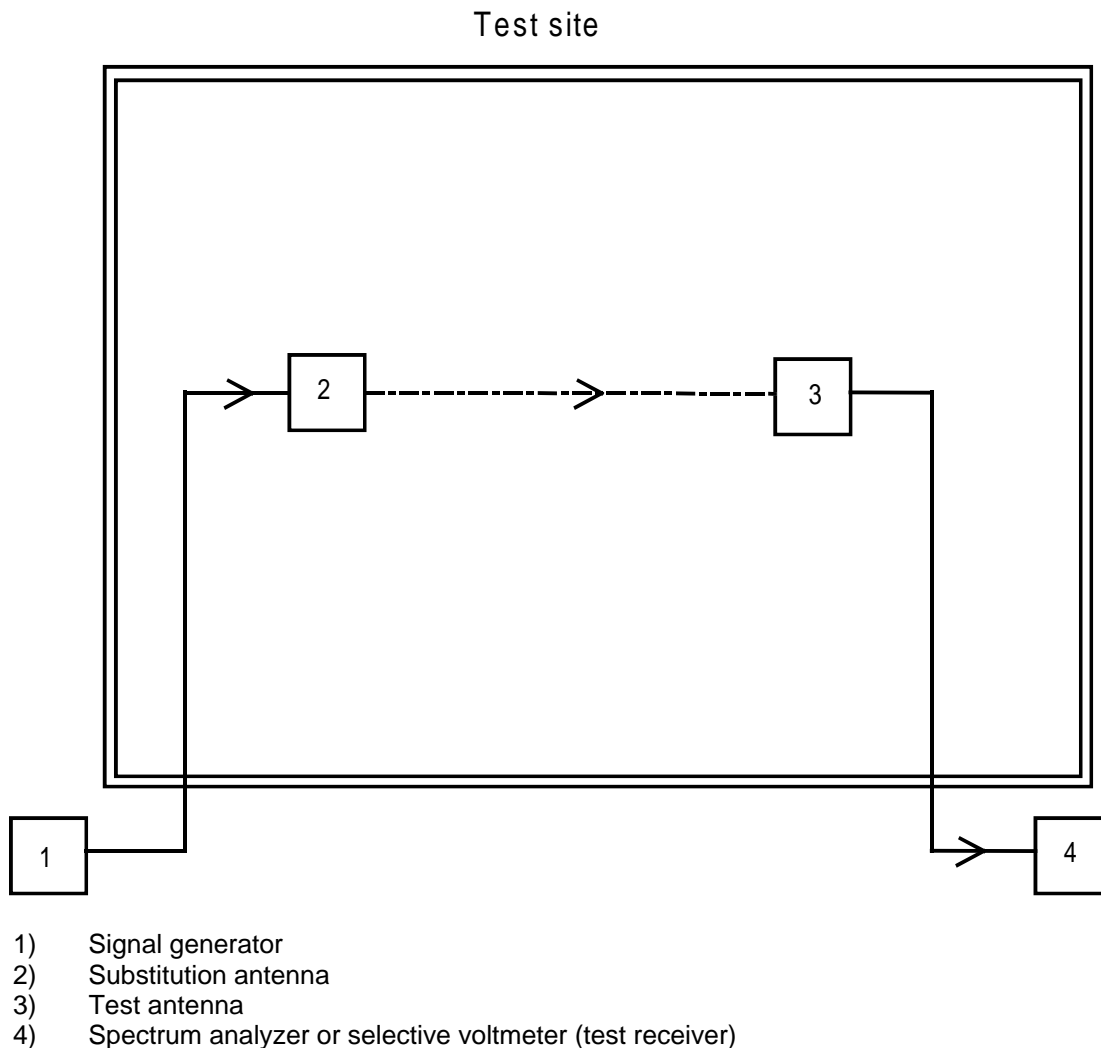

Figure 10: Measurement arrangement

- d) at each frequency at which a component is detected, the sample shall be rotated to obtain maximum response and the effective radiated power of that component determined by a substitution measurement, using the measurement arrangement of figure 10;
- e) the measurements shall be repeated with the test antenna in the orthogonal polarisation plane;
- f) the measurements shall be repeated with the transmitter in the "stand-by" position.

The limit(s) corresponding to this parameter can be found in subclause 5.1.5 .

8.7 Intermodulation attenuation

This requirement applies only to transmitters to be used in base stations.

8.7.1 Definition

For the purpose of this ETS the intermodulation attenuation is a measure of the capability of a transmitter to inhibit the generation of signals in its non-linear elements caused by the presence of the carrier and an interfering signal entering the transmitter via its antenna.

8.7.2 Method of measurement

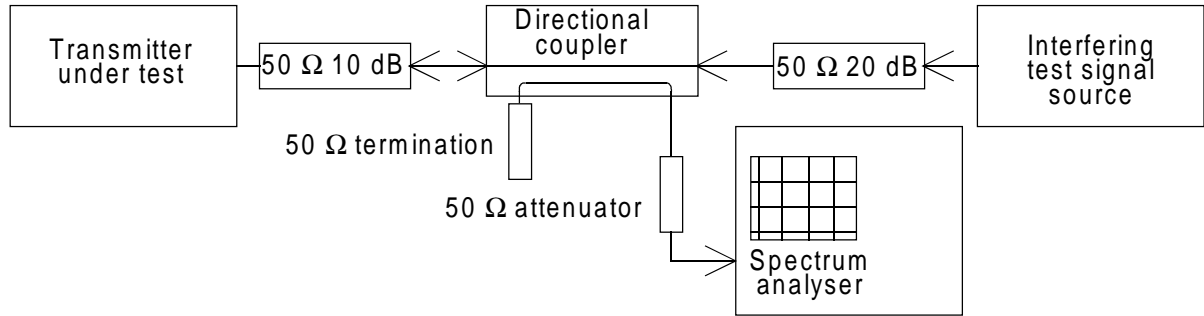

Figure 11: Measurement arrangement

The measurement arrangement shown in figure 11 shall be used.

The transmitter shall be connected to a 50 Ω 10 dB power attenuator and via a (directional) coupler to a spectrum analyser. An additional attenuator may be required between the directional coupler and the spectrum analyser to avoid overloading.

In order to reduce the influence of mismatch errors it is important that the 10 dB power attenuator is coupled to the transmitter under test with the shortest possible connection.

The interfering test signal source may be either a transmitter providing the same power output as the transmitter under test and be of a similar type, or a signal generator and a linear power amplifier capable of delivering the same output power as the transmitter under test.

The (directional) coupler shall have an insertion loss of less than 1 dB. If a directional coupler is used, it shall have a sufficient bandwidth and a directivity of at least 20 dB.

The transmitter under test and the test signal source shall be physically separated in such a way that the measurement is not influenced by direct radiation.

The transmitter under test shall be unmodulated and the spectrum analyzer adjusted to give a maximum indication with a frequency scan width of 500 kHz.

The interfering test signal source shall be unmodulated and the frequency shall be within 50 kHz to 100 kHz above the frequency of the transmitter under test.

The frequency shall be chosen in such a way that the intermodulation components to be measured do not coincide with other spurious components. The power output of the interfering test signal source shall be adjusted to the carrier power level of the transmitter under test by the use of a power meter.

The intermodulation component shall be measured by direct observation on the spectrum analyzer of the ratio of the largest third order intermodulation component with respect to the carrier.

This measurement shall be repeated with the interfering test signal source at a frequency within 50 kHz to 100 kHz below the frequency of the transmitter under test.

The limit(s) corresponding to this parameter can be found in subclause 5.1.6 .

8.8 Transmitter attack time

This measurement does not apply to transmitters intended for continuous transmission only.

8.8.1 Definition

The transmitter attack time (t_a) is the time which elapses between the initiation of the "transmitter on" function (T_{xon} , see definitions in subclause 8.10.1) and:

- a) the moment when the transmitter output power has reached a level 1 dB below or 1,5 dB above the steady state power (P_c) and maintains a level within +1,5 dB / -1 dB from P_c thereafter as seen on the measuring equipment or in the plot of power as a function of time; or
- b) the moment after which the frequency of the carrier always remains within ± 1 kHz of its steady state frequency, F_c , as seen on the measuring equipment or the plot of frequency as a function of time;

whichever occurs later (subclause 8.10, figures 12 and 13).

The measured value of t_a is t_{am} ; its limit is t_{al} .

The choice of conditions for b), above, is made in order to make the method of measurement easier to perform and to have good repeatability. It is expected that under these conditions, in the worst case, the frequency of the carrier will be within the frequency tolerance of the steady state, df_e , a few ms after the end of the attack time as defined in b) above.

8.8.2 Method of measurement

For the test arrangement see subclause 8.10.3.2, figure 15.

The measurement procedure shall be as follows:

- a) the transmitter is connected to a RF detector and to a test discriminator via a matched test load. The attenuation of the test load shall be chosen in such a way that the input of the test discriminator is protected against overload and the limiter amplifier of the test discriminator operates correctly in the limiting range as soon as the transmitter carrier power (before attenuation) exceeds 1mW. A dual trace storage oscilloscope (or a transient recorder) records the amplitude transient from the detector on a logarithmic scale and the frequency transient from the discriminator;

A trigger device may be required to ensure that the start of the sweep of the oscilloscope time base occurs at the instant at which the "transmitter on" function is initiated. The measuring arrangement is shown in figure 15 of subclause 8.10.

A spectrum analyzer and a test discriminator/storage oscilloscope can also be used.

- b) the traces of the oscilloscope shall be calibrated in power and frequency (Y axes) and in time (X axis), using the signal generator;
- c) the transmitter attack time shall be measured by direct reading on the oscilloscope while the transmitter is preferably unmodulated.

The limit(s) corresponding to this parameter can be found in subclause 5.1.7.

8.9 Transmitter release time

This measurement does not apply to transmitters intended for continuous transmission only.

8.9.1 Definition

The transmitter release time (t_r) is the time which elapses between the initiation of the "transmitter off" function (T_{xoff} , see definitions in subclause 8.10.1) and the moment when the transmitter output power has reduced to a level 50 dB below the steady state power (P_c) and remains below this level thereafter as seen on the measuring equipment or in the plot of power as a function of time (subclause 8.10, figure 14).

The measured value of t_r is t_{rm} ; its limit is t_{rl} .

8.9.2 Method of measurement

For the test arrangement see subclause 8.10.3.2, figure 15.

The measurement procedure shall be as follows:

- a) the transmitter is connected to a RF detector and to a test discriminator via a matched power attenuator. Its attenuation shall be chosen in such a way that the input of the test discriminator is protected against overload and that the limiter amplifier of the test discriminator operates correctly in the limiting range as long as the transmitter carrier power (before attenuation) exceeds 1mW. A dual trace storage oscilloscope (or a transient recorder) records the amplitude transient from the detector on a logarithmic scale and the frequency transient from the discriminator. A trigger device may be required to ensure that the start of the sweep of the oscilloscope timebase occurs the instant at which the "transmitter off" function is initiated. If the transmitter possesses an automatic powering down facility (e.g. in the case of fixed length message transmission), it may replace the trigger device for starting the sweep of the oscilloscope. The measuring arrangement is shown in figure 15 of subclause 8.10;

A spectrum analyzer and a test discriminator/storage oscilloscope can also be used.

- b) the traces of the oscilloscope shall be calibrated in power and frequency (Y axes) and in time (X axis) by replacing the transmitter and test load by the signal generator;
- c) the transmitter release time shall be measured by direct reading on the oscilloscope while the transmitter is preferably unmodulated.

The limit(s) corresponding to this parameter can be found in subclause 5.1.8 .

8.10 Transient behaviour of the transmitter

Limitations of the transmitter attack and release times (subclauses 8.8 and 8.9) are intended to improve the spectrum efficiency. The attack and release times can also be used to allow the definition of the timings in the protocols.

The measurements of transient behaviour are intended to ensure that the transmitter will not cause harmful interference in the other channels when the operating frequency is outside the tolerance of the steady state df_e .

The method of measurement includes:

- the drawing of plots of "carrier power as a function of time" and "carrier frequency as a function of time";
- the evaluation of the slopes of those plots between predetermined points;
- the measurement of the transient power in the adjacent channels.

8.10.1 Definitions

The transient behaviour of the transmitter is defined as the time-dependency of transmitter frequency, power and spectrum when the RF output power is switched on and off.

The following powers, frequencies, frequency tolerances and transient times are specified:

P_o : rated power;

P_c : steady state power;

P_a : adjacent channel transient power. It is transient power falling into the adjacent channels due to switching the transmitter on and off (subclause 8.10.3.3);

F_o : nominal carrier frequency;

F_c : steady state carrier frequency;

df : frequency difference (relative to F_o) or frequency error (absolute) (subclause 8.1.1), of the transmitter;

df_e : limit of the frequency error (df) in the steady state (subclause 5.1.1);

df₀: limit of the frequency difference (df) equal to 1 kHz. If it is impossible to switch off the transmitter modulation one half channel separation is added;

df_c: limit of the frequency difference (df) during the transient, equal to one half channel separation; while the frequency difference is less than df_c, the carrier frequency remains within the boundaries of the allocated channel. If it is impossible to switch off the transmitter modulation another half channel separation is added;

T_{xon}: time at which the final irrevocable logic decision to power on the transmitter is taken.

If an access point is unavailable then the time after which the carrier power exceeds (P_c - 50 dB) may be taken. This fact shall be recorded in the test report.

The power starts to rise somewhere between T_{xon} and t_{on} (RF-power on).

t_{on}: time when the carrier power, measured at the transmitter output, exceeds P_c - 30 dB;

t_p: period of time starting at t_{on} and finishing when the power reaches P_c - 6dB;

t_a: transmitter attack time as defined in subclause 8.8;

t_{am}: measured value of t_a;

t_{al}: limit of t_{am} as given in subclause 5.1.7;

T_{xoff}: time at which the final irrevocable logic decision to power off the transmitter is taken.

If an access point is unavailable then the time after which the carrier power remains below (P_c - 3 dB) may be taken. This fact shall be recorded in the test report.

The power starts to decrease somewhere between T_{xoff} and the moment when P_c - 6dB is reached (RF-power off).

t_{off}: time when the carrier power falls below P_c - 30dB;

t_d: period of time starting when the power falls below P_c - 6dB and finishing at t_{off};

t_r: transmitter release time as defined in subclause 8.9 (after the end of the release time, the power remains below P_c - 50 dB);

t_{rm}: measured value of t_r;

t_{rl}: limit of t_{rm} as given in subclause 5.1.8.

If use is made of a synthesizer and/or a Phase Locked Loop (PLL) system, for determining the transmitter frequency, then the transmitter shall be inhibited when synchronisation is absent or in the case of PLL, when the loop system is not locked.

8.10.2 Timings, frequencies and powers

Figures 12, 13 and 14 represent the timings, frequencies and powers as defined in subclauses 8.8.1, 8.9.1 and 8.10.1.

The corresponding limits are given in subclauses 5.1.7, 5.1.8 and 5.1.9.

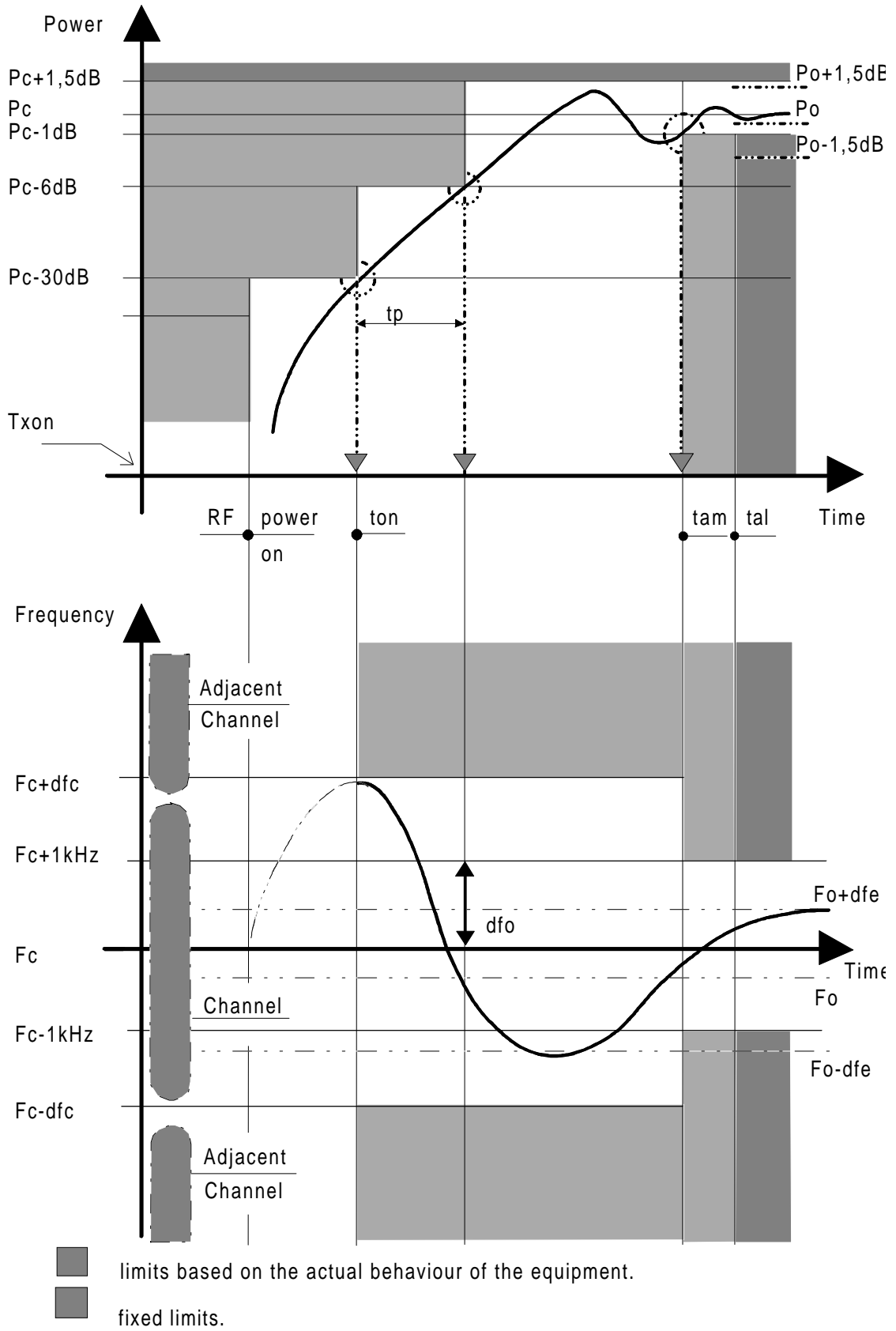

Figure 12: Transmitter attack time according to subclause 8.8.1 a) and transient behaviour during switch-on. (Case where the attack time is given by the behaviour of the power rise)

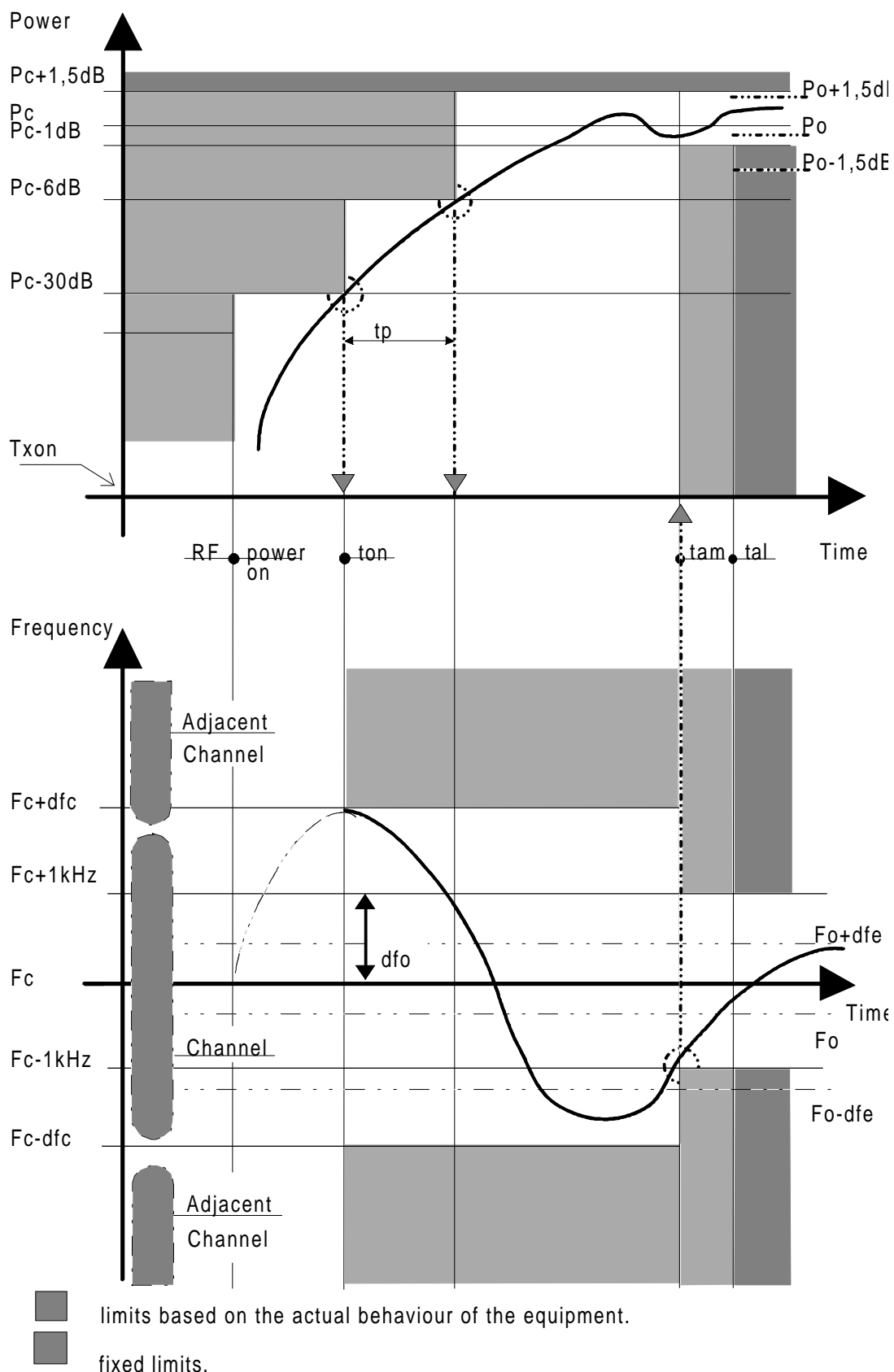

Figure 13: Transmitter attack time according to subclause 8.8.1 b) and transient behaviour during switch-on. (Case where the attack time is given by the behaviour of the frequency)

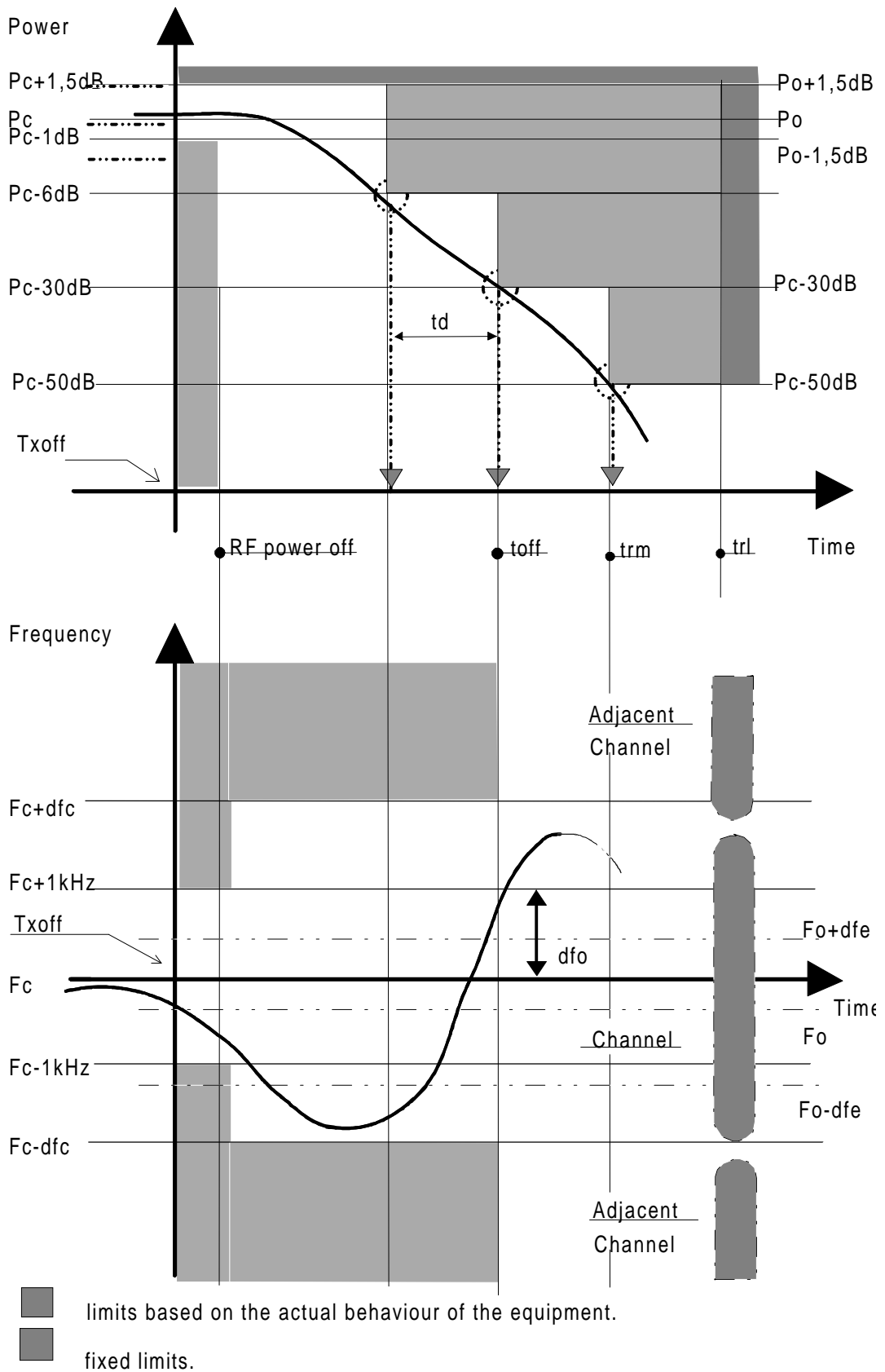

Figure 14: Transmitter release time according to subclause 8.9.1 and transient behaviour, during switch-off

8.10.3 Methods of measurement

The transient timings (switch on/switch off cases) and the frequency differences occurring during these periods of time can be measured by means of a spectrum analyzer and a test discriminator which meets the requirements indicated in subclause 8.10.3.2. The corresponding limits are given in subclause 5.1.9.1.

The power, impairing the operation on the adjacent channels, can be measured using an appropriate transient power measuring device which meets the requirements of subclause 8.10.3.4. The corresponding limits are given in subclause 5.1.9.2.

8.10.3.1 Time domain measurements of power and frequency

The measurement shall be performed with the transmitter unmodulated if possible. If the transmitter cannot be operated unmodulated, the measurement shall be performed with modulation and this fact shall be recorded in the test report.

The transmitter shall be connected to the test set-up as shown in figure 15.

The calibration of the test set-up shall be checked. The transmitter output is connected to the input of the spectrum analyzer and test discriminator via power attenuators and a power splitter.

The attenuation of the power attenuators shall be chosen in such a way that the input of the test equipment is protected against overload and that the limiter amplifier of the test discriminator operates correctly in the limiting range when the power conditions of subclause 8.10.1 are reached.

The spectrum analyzer is set to measure and display power as a function of time ("zero span mode").

The test discriminator shall be calibrated. This can be done by feeding RF voltages from a signal generator with defined frequency differences from the nominal frequency of the transmitter.

By appropriate means, a triggering pulse is generated for the test equipment when the T_{xon} function or the T_{xoff} function are activated.

The "RF power on" and the "RF power off" can be monitored.

The voltage occurring at the test discriminator output shall be recorded as a function of time in correspondence with the power level on a storage device or a transient recorder. This voltage is a measure of the frequency difference. The elapsed periods of time during the frequency transient can be measured using the time base of the storage device. The output of the test discriminator is valid only after t_{on} and before t_{off} .

A cross over impulse (noise to signal) of the instrument, if any, shall be disregarded.

8.10.3.2 Test arrangement and characteristics of the test discriminator

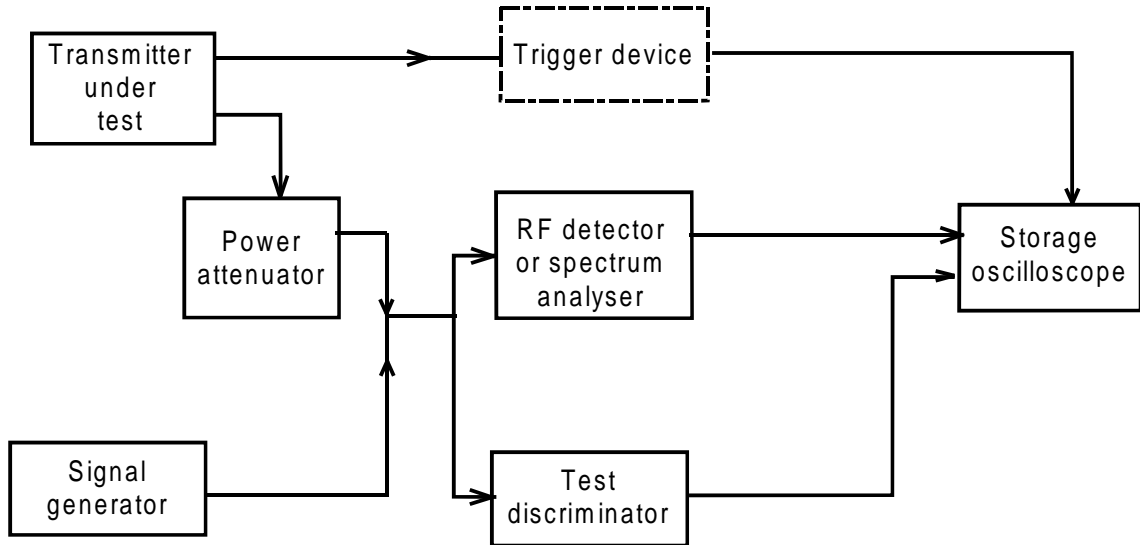

Figure 15: Test arrangement for transient behaviour of transmitter power and frequency, including transmitter attack and release time

The test discriminator may consist of a mixer and a local oscillator (providing the auxiliary frequency) used to convert the transmitter frequency to be measured into the frequency fed to the (broadband) limiter amplifier and the associated broadband discriminator:

- the test discriminator shall be sensitive enough to measure input signals down to $P_c - 30$ dB;
- the test discriminator shall be fast enough to display the frequency deviations (approximately 100 kHz/100 ms);
- the test discriminator output shall be dc coupled.

8.10.3.3 Adjacent channel transient power measurements

The transmitter under test shall be connected via the power attenuator to the "adjacent channel transient power measuring device" as described in subclause 8.10.3.4, so that the level at its input is suitable, e.g. between 0 dBm and - 10 dBm when the transmitter power is P_c .

The measurement shall be performed with the transmitter unmodulated if possible. If the transmitter cannot be operated unmodulated, the measurement shall be performed with modulation and this fact shall be recorded in the test report.

The measurement procedure shall be as follows:

- a) the transmitter shall be operated at the maximum rated carrier power level, under normal test conditions (subclause 6.3);
- b) the tuning of the "transient power measuring device" shall be adjusted so that a maximum response is obtained. This is the 0 dBc reference level;

The transmitter shall then be switched off.

- c) the tuning of the "transient power measuring device" shall be adjusted away from the carrier so that its - 6 dB response nearest to the transmitter carrier frequency is located at a displacement from the nominal carrier frequency as given in table 8;

Table 8: Frequency displacement

Channel separation (kHz)	Displacement (kHz)
12,5	8,25
20	13
25	17

- d) the transmitter shall be switched on;
- e) the spectrum analyzer shall be used to record the envelope of the transient power as a function of time (approximately 50 ms duration). The peak envelope transient power shall be noted in dBc;
- f) the transmitter shall be switched off;
- g) the spectrum analyzer shall be used to record the envelope of the transient power as a function of time (approximately 50 ms duration). The peak envelope transient power shall be noted in dBc;
- h) steps d) to g) shall be repeated five times and the highest response during "switch-on" and "switch-off" conditions shall be recorded;
- j) steps c) to h) shall be repeated with the "transient power measuring device" tuned to the other side of the carrier;
- k) the adjacent channel transient power during the attack and release times is the dBc value corresponding to the highest of the values recorded in step h). This value shall be recorded.

8.10.3.4 Characteristics of the adjacent channel transient power measuring device

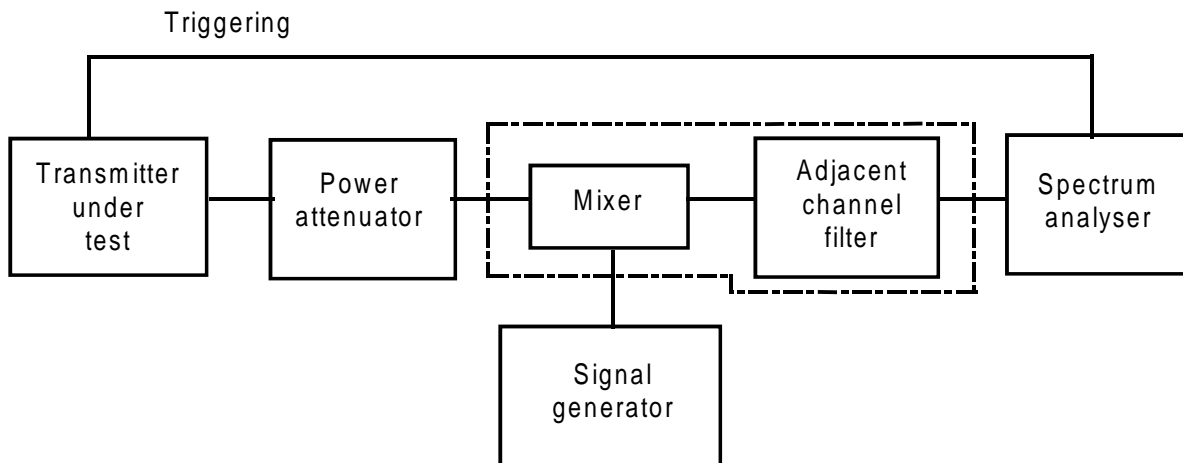

Figure 16: Adjacent channel transient power measuring device measurement arrangement

The adjacent channel transient power measuring device may be as follows:

- mixer: 50 Ω balanced diode mixer; with an appropriate local oscillator level, for example + 7 dBm;
- adjacent channel filter: matched to 50 Ω (annex B);
- spectrum analyzer: 100 kHz bandwidth, peak detection, or power/time measurement provision.

9 Methods of measurement for receiver parameters

9.1 Maximum usable sensitivity (data or messages, conducted)

9.1.1 Definition

The maximum usable sensitivity (data or messages, conducted) is the minimum level of signal (emf) at the receiver input, produced by a carrier at the nominal frequency of the receiver, modulated with the normal test signal (subclause 7.3), which will, without interference, produce after demodulation a data signal with a specified bit error ratio or a specified successful message ratio. The specified bit error ratio is 10^{-2} . The specified successful message ratio is 80 %.

9.1.2 Method of measurement with continuous bit streams

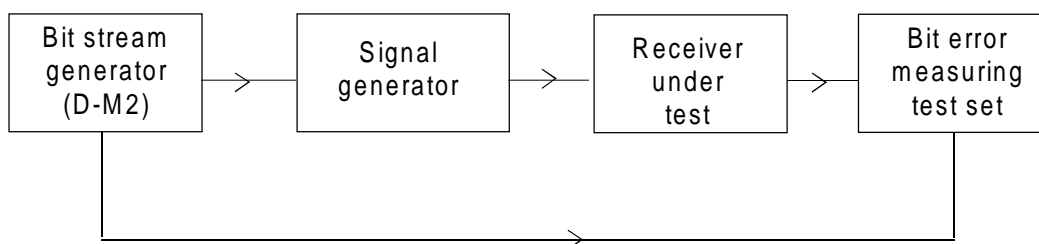

Figure 17: Measurement arrangement

The measurement procedure shall be as follows:

- an input signal with a frequency equal to the nominal frequency of the receiver, modulated by the normal test signal D-M2 (subclause 7.3), shall be applied to the receiver input terminals;
- the bit pattern of the modulating signal shall be compared to the bit pattern obtained from the receiver after demodulation;
- the emf of the input signal to the receiver is adjusted until the bit error ratio is 10^{-2} or better. (When the value of 10^{-2} cannot be reached exactly, this shall be taken into account in the evaluation of the measurement uncertainty (ETR 028 [4]));
- the maximum usable sensitivity is the emf of the input signal to the receiver;
- the measurement shall be repeated under extreme test conditions (subclauses 6.4.1 and 6.4.2 applied simultaneously).

The limit(s) corresponding to this parameter can be found in subclause 5.2.1.

9.1.3 Method of measurement with messages

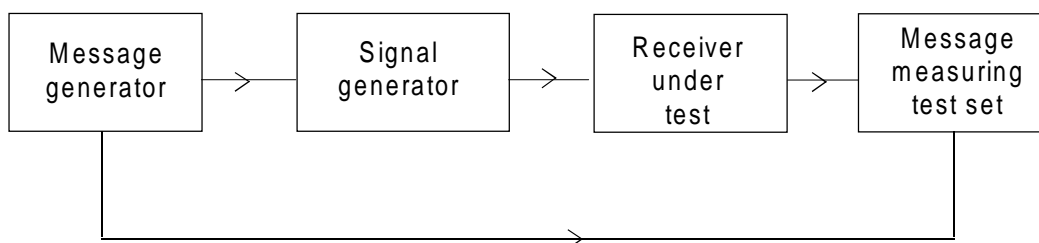

Figure 18: Measurement arrangement

The measurement procedure shall be as follows:

- a) an input signal with a frequency equal to the nominal frequency of the receiver, having normal test modulation (subclause 7.3), in accordance with the instructions of the manufacturer (and approved by the testing laboratory), shall be applied to the receiver input terminals;
- b) the level of this signal shall be such that a successful message ratio of less than 10 % is obtained;
- c) the normal test signal (subclause 7.3) shall then be transmitted repeatedly whilst observing in each case whether or not a message is successfully received;

The level of the input signal shall be increased by 2 dB for each occasion that a message is not successfully received.

The procedure shall be continued until three consecutive messages are successfully received.

The level of the input signal shall then be noted.

- d) the level of the input signal shall be reduced by 1 dB and the new value noted;

The normal test signal (subclause 7.3) shall then be transmitted 20 times. In each case, if a message is not successfully received the level of the input signal shall be increased by 1 dB and the new value noted.

If a message is successfully received, the level of the input signal shall not be changed until three consecutive messages have been successfully received. In this case, the level of the input signal shall be reduced by 1 dB and the new value noted.

No level of the input signal shall be noted unless preceded by a change in level.

- e) the maximum usable sensitivity is the average of the values noted in steps c) and d) (which provides the level corresponding to the successful message ratio of 80 %). This value shall be recorded;
- f) the measurement shall be repeated under extreme test conditions (subclauses 6.4.1 and 6.4.2 applied simultaneously).

The limit(s) corresponding to this parameter can be found in subclause 5.2.1.

9.2 Average usable sensitivity (data or messages, field strength)

This measurement applies only to equipment without an external antenna connector.

For the definition and the method of measurement, see ETS 300 390 [3], subclause 9.1.

The limit(s) corresponding to this parameter can be found in subclause 5.2.1 of ETS 300 390 [3], as stated in subclause 5.2.2 of this ETS.

9.3 Level of the wanted signal for the degradation measurements (data or messages)

Degradation measurements are those measurements which are made on the receiver to establish the degradation of the performance of the receiver due to the presence of (an) unwanted (interfering) signal(s).

The level of the wanted signal for the degradation measurements, under normal test conditions (subclause 6.3), shall be an emf of + 6 dB μ V. It is 3 dB above the limit of the maximum usable sensitivity (data or messages, conducted).

9.4 Error behaviour at high input levels

9.4.1 Definition

The error behaviour (performance) at high input levels (noise free operation) is defined by the bit error ratio (continuous bit stream) or by the number of messages lost or corrupted when the level of the wanted signal is significantly above the maximum usable sensitivity.

9.4.2 Method of measurement with continuous bit streams

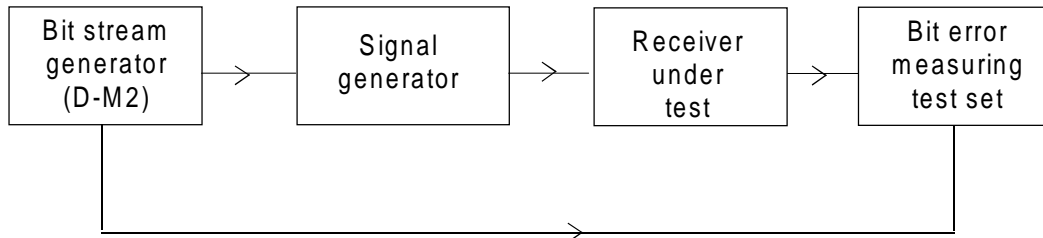

Figure 19: Measurement arrangement

The measurement procedure shall be as follows:

- an input signal with a frequency equal to the nominal frequency of the receiver, modulated by the normal test signal D-M2 (subclause 7.3), shall be applied to the receiver input terminals;
- the bit pattern of the modulating signal shall be compared to the bit pattern obtained from the receiver after demodulation;
- the level of the input signal shall be adjusted to a level which is 30 dB above the level of the wanted signal for the degradation measurements (subclause 9.3);
- the number of errors that occur at the data output terminals or at a special measuring terminal of the receiver, during a period of 3 minutes, shall be counted;
- the measurement shall be repeated with the level of the input signal of the receiver adjusted to a level which is 100 dB above the level of the wanted signal for the degradation measurements (subclause 9.3).

The limit(s) corresponding to this parameter can be found in subclause 5.2.3 .

9.4.3 Method of measurement with messages

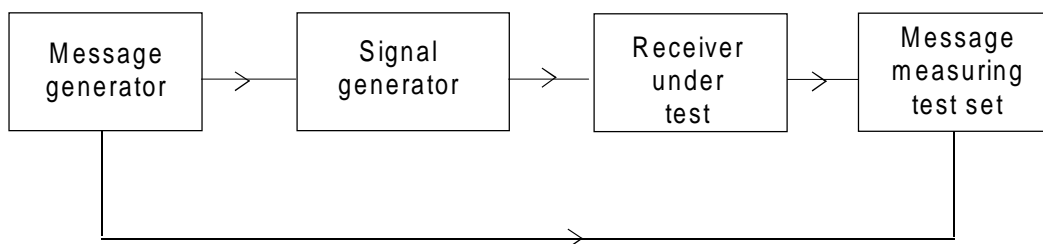

Figure 20: Measurement arrangement

The measurement procedure shall be as follows:

- an input signal with a frequency equal to the nominal frequency of the receiver, having normal test modulation (subclause 7.3), in accordance with the instructions of the manufacturer (and approved by the testing laboratory), shall be applied to the receiver input terminals;
- the level of the input signal shall be adjusted to a level which is 30 dB above the level of the wanted signal for the degradation measurements (subclause 9.3);

- c) the normal test signal (subclause 7.3) shall then be transmitted 100 times whilst observing in each case whether or not a message is successfully received;
- d) the number of messages not successfully received shall be recorded;
- e) the measurement shall be repeated with the input signal of the receiver at a level which is 100 dB above the wanted signal for the degradation measurements (subclause 9.3).

The limit(s) corresponding to this parameter can be found in subclause 5.2.3.

9.5 Co-channel rejection

9.5.1 Definition

The co-channel rejection is a measure of the capability of the receiver to receive a wanted modulated signal without exceeding a given degradation due the presence of an unwanted modulated signal, both signals being at the nominal frequency of the receiver.

9.5.2 Method of measurement with continuous bit streams

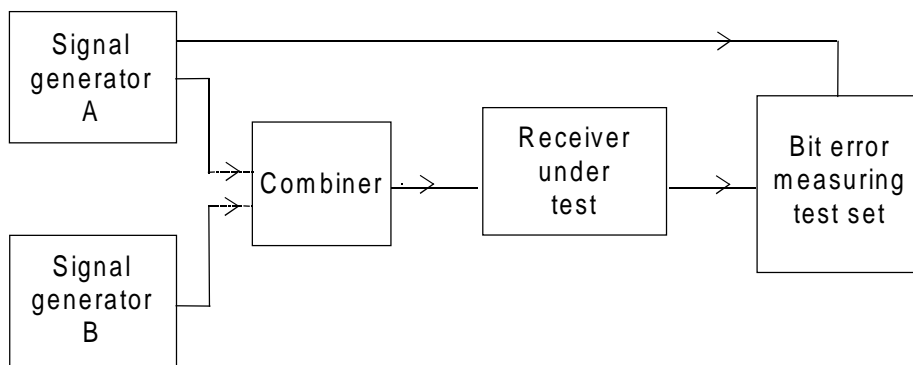

Figure 21: Measurement arrangement

The measurement procedure shall be as follows:

- a) two signal generators, A and B, shall be connected to the receiver via a combining network (subclause 7.1);

The wanted signal, provided by signal generator A, shall be at the nominal frequency of the receiver and shall be modulated by the normal test signal D-M2 (subclause 7.3).

The unwanted signal, provided by signal generator B, shall be modulated with signal A-M3 (subclause 7.3).

Both input signals shall be at the nominal frequency of the receiver under test.

- b) initially, signal generator B (unwanted signal) shall be switched off (maintaining the output impedance);

The level of the wanted signal from generator A shall be adjusted to a level which is 3 dB above the level of the limit of the maximum usable sensitivity as specified in subclause 9.3 (data or messages), at the receiver input terminals (i.e. 6 dB above 1 μ V emf under normal test conditions).

- c) signal generator B shall then be switched on, and the level of the unwanted signal adjusted until a bit error ratio of 10^{-1} or worse is obtained;
- d) the normal test signal D-M2 shall be transmitted whilst observing the bit error ratio;
- e) the level of the unwanted signal shall be reduced in steps of 1 dB until a bit error ratio of 10^{-2} or better is obtained. The level of the unwanted signal shall then be noted;

- f) for each frequency of the unwanted signal, the co-channel rejection ratio shall be expressed as the ratio, in dB, of the level of the unwanted signal to the level of the wanted signal, at the receiver input. This ratio shall be recorded;
- g) the measurement shall be repeated for displacements of the unwanted signal of $\pm 12\%$ of the channel separation;
- h) the co-channel rejection ratio of the equipment under test shall be expressed as the lowest of the three values expressed in dB, calculated in step f);

The value of the co-channel rejection ratio, expressed in dB, is generally negative (therefore, for example, - 12 dB is lower than - 8 dB).

The limit(s) corresponding to this parameter can be found in subclause 5.2.4.

9.5.3 Method of measurement with messages

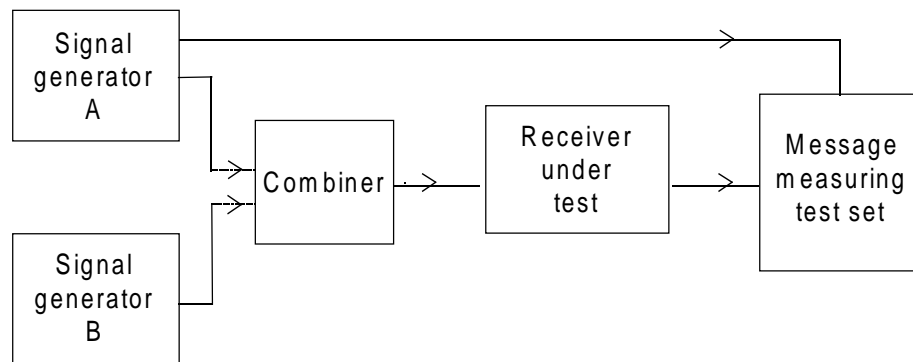

Figure 22: Measurement arrangement

The measurement procedure shall be as follows:

- a) two signal generators, A and B, shall be connected to the receiver via a combining network (subclause 7.1);

The wanted signal, provided by signal generator A, shall be at the nominal frequency of the receiver and shall have normal test modulation (subclause 7.3).

The unwanted signal, provided by signal generator B, shall be modulated with signal A-M3 (subclause 7.3).

Both input signals shall be at the nominal frequency of the receiver.

- b) initially, signal generator B (unwanted signal) shall be switched off (maintaining the output impedance);

The level of the wanted signal from generator A shall be adjusted to a level which is 3 dB above the level of the limit of the maximum usable sensitivity as specified in subclause 9.3) (data or messages) at the receiver input terminals (i.e. 6 dB above 1 μ V emf under normal test conditions).

- c) signal generator B shall then be switched on, and the level of the unwanted signal adjusted until a successful message ratio of less than 10 % is obtained;
- d) the normal test signal (subclause 7.3) shall then be transmitted repeatedly whilst observing in each case whether or not a message is successfully received;

The level of the unwanted signal shall be reduced by 2 dB for each occasion that a message is not successfully received.

The procedure shall be continued until three consecutive messages are successfully received. The level of the input signal shall then be noted.

- e) the level of the unwanted signal shall be increased by 1 dB and the new value noted;

The normal test signal (subclause 7.3) shall then be transmitted 20 times. In each case, if a message is not successfully received the level of the unwanted signal shall be reduced by 1 dB and the new value noted.

If a message is successfully received, the level of the unwanted signal shall not be changed until three consecutive messages have been successfully received. In this case the unwanted signal shall be increased by 1 dB and the new value noted.

No level of the unwanted signal level shall be noted unless preceded by a change in level.

The average of the values noted in steps d) and e) (which provides the level corresponding to the successful message ratio of 80 %) shall be noted.

- f) for each frequency of the unwanted signal, the co-channel rejection ratio shall be expressed as the ratio, in dB, of the average level noted in step e) to the level of the wanted signal, at the receiver input. This ratio shall be recorded;
- g) the measurement shall be repeated for displacements of the unwanted signal of $\pm 12\%$ of the channel separation;
- h) the co-channel rejection of the equipment under test shall be expressed as the lowest of the three values expressed in dB, calculated in step f);

The value of the co-channel rejection ratio, expressed in dB, is generally negative (therefore, for example, - 12 dB is lower than - 8 dB).

The limit(s) corresponding to this parameter can be found in subclause 5.2.4.

9.6 Adjacent channel selectivity

9.6.1 Definition

The adjacent channel selectivity is a measure of the capability of the receiver to receive a wanted modulated signal without exceeding a given degradation due to the presence of an unwanted signal which differs in frequency from the wanted signal by an amount equal to the adjacent channel separation for which the equipment is intended.

9.6.2 Method of measurement with continuous bit streams

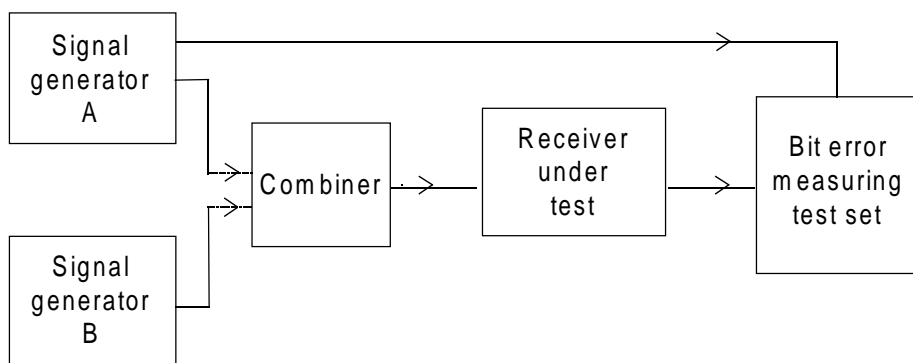

Figure 23: Measurement arrangement

The measurement procedure shall be as follows:

- a) two signal generators, A and B, shall be connected to the receiver via a combining network (subclause 7.1);

The wanted signal, provided by signal generator A, shall be at the nominal frequency of the receiver and shall be modulated by the normal test signal D-M2 (subclause 7.3).

The unwanted signal, provided by signal generator B, shall be modulated with signal A-M3 (subclause 7.3) and shall be at the frequency of the channel immediately above that of the wanted signal.

- b) initially, signal generator B (unwanted signal) shall be switched off (maintaining the output impedance);

The level of the wanted signal from generator A shall be adjusted to the level which is 3 dB above the level of the limit of the maximum usable sensitivity as specified in subclause 9.3 (data or messages), at the receiver input terminals (i.e. 6 dB above 1 μ V emf under normal test conditions).

- c) signal generator B shall then be switched on, and the level of the unwanted signal adjusted until a bit error ratio of 10^{-1} or worse is obtained;
- d) the normal test signal D-M2 shall be transmitted whilst observing the bit error ratio;
- e) the level of the unwanted signal shall be reduced in steps of 1 dB until a bit error ratio of 10^{-2} or better is obtained. The level of the unwanted signal shall then be noted;
- f) for each adjacent channel, the selectivity shall be expressed as the ratio, in dB, of the level of the unwanted signal to the level of the wanted signal, at the receiver input. This ratio shall be recorded;
- g) the measurement shall be repeated with the unwanted signal at the frequency of the channel below that of the wanted signal;
- h) the adjacent channel selectivity of the equipment under test shall be expressed as the lower of the two values measured in the upper and lower channels nearest to the receiving channel (see step f) above);
- j) the measurement shall be repeated under extreme test conditions (subclauses 6.4.1 and 6.4.2 applied simultaneously), using the level of the wanted signal, as specified in subclause 9.3 (data or messages), increased by 6 dB.

If analogue measurements according to ETS 300 086 [2] have been made before, including adjacent channel selectivity under extreme test conditions, the adjacent channel selectivity (data or messages) shall be measured at normal test conditions only.

NOTE : This is a valid procedure, because the degradation of adjacent channel selectivity at extreme test conditions is known by the analogue measurement results.

The limit(s) corresponding to this parameter can be found in subclause 5.2.5.

9.6.3 Method of measurement with messages

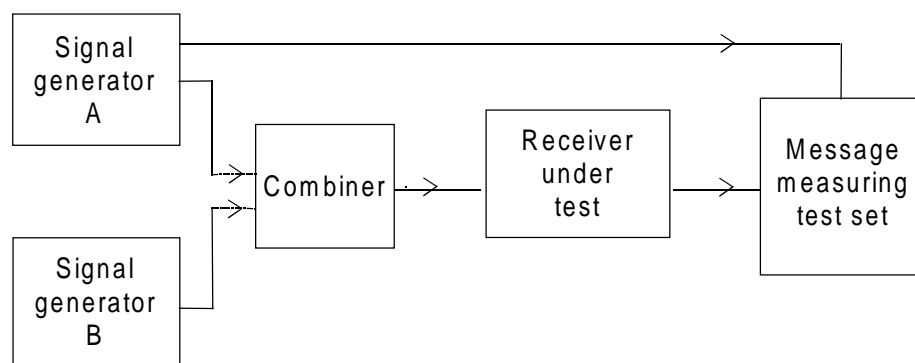

Figure 24: Measurement arrangement

The method of measurement shall be as follows:

- a) two signal generators, A and B, shall be connected to the receiver via a combining network (subclause 7.1);

The wanted signal, provided by signal generator A, shall be at the nominal frequency of the receiver and shall have normal test modulation (subclause 7.3).

The unwanted signal, provided by signal generator B, shall be modulated with signal A-M3 (subclause 7.3) and shall be at the frequency of the channel immediately above that of the wanted signal.

- b) initially, signal generator B (unwanted signal) shall be switched off (maintaining the output impedance);

The level of the wanted signal from generator A shall be adjusted to the level which is 3 dB above the level of the limit of the maximum usable sensitivity as specified in subclause 9.3 (data or messages), at the receiver input terminals (i.e. 6 dB above 1 μ V emf under normal test conditions).

- c) signal generator B shall then be switched on, and the level of the unwanted signal adjusted until a successful message ratio of less than 10 % is obtained;

- d) the normal test signal (subclause 7.3) shall then be transmitted repeatedly whilst observing in each case whether or not a message is successfully received;

The level of the unwanted signal shall be reduced by 2 dB for each occasion that a message is not successfully received.

The procedure shall be continued until three consecutive messages are successfully received. The level of the input signal shall then be noted.

- e) the level of the unwanted signal shall be increased by 1 dB and the new value noted;

The normal test signal (subclause 7.3) shall then be transmitted 20 times. In each case, if a message is not successfully received the level of the unwanted signal shall be reduced by 1 dB and the new value noted.

If a message is successfully received, the level of the unwanted signal shall not be changed until three consecutive messages have been successfully received. In this case the unwanted signal shall be increased by 1 dB and the new value noted.

No level of the unwanted signal shall be noted unless preceded by a change in level.

The average of the values noted in steps d) and e) (which provides the level corresponding to the successful message ratio of 80 %) shall be noted.

- f) for each adjacent channel, the selectivity shall be expressed as the ratio, in dB, of the average level noted in step e) to the level of the wanted signal, at the receiver input. This value shall be recorded;

- g) the measurement shall be repeated with the unwanted signal at the frequency of the channel below that of the wanted signal;

- h) the adjacent channel selectivity of the equipment under test shall be expressed as the lower of the two values measured in the upper and lower adjacent channel nearest to the receiving channel (see step f) above);

- j) the measurement shall be repeated under extreme test conditions (subclauses 6.4.1 and 6.4.2 applied simultaneously), using the level of the wanted signal, as specified in subclause 9.3 (data or messages), increased by 6 dB.

If analogue measurements according to ETS 300 086 [2] have been made before, including adjacent channel selectivity under extreme test conditions, the adjacent channel selectivity (data or messages) shall be measured at normal test conditions only.

NOTE : This is a valid procedure because the degradation of adjacent channel selectivity at extreme test conditions is known by the analogue measurement results.

The limit(s) corresponding to this parameter can be found in subclause 5.2.5.

9.7 Spurious response rejection

Spurious responses may occur at all frequencies throughout the frequency spectrum and the requirements of this ETS shall be met for all frequencies. However, for practical reasons the measurements for type testing shall be performed as specified in this ETS. More specifically, this method of measurement is not intended to capture all spurious responses but selects those that have a high probability of being present. However, in a limited frequency range close to the nominal frequency of the receiver, it has been considered impossible to determine the probability of a spurious response and therefore a search shall be performed over this limited frequency range. This method provides a high degree of confidence that the equipment also meets the requirements at frequencies not being measured.

9.7.1 Definition

The spurious response rejection is a measure of the capability of the receiver to receive a wanted modulated signal without exceeding a given degradation due to the presence of an unwanted modulated signal at any other frequency, at which a response is obtained.

9.7.2 Introduction to the method of measurement

To determine the frequencies at which spurious responses can occur the following calculations shall be made:

a) calculation of the "limited frequency range":

- the limited frequency range is defined as the frequency of the local oscillator signal (f_{LO}) applied to the first mixer of the receiver plus or minus the sum of the intermediate frequencies (f_{i1}, \dots, f_{in}) and a half the switching range (sr) of the receiver (clause 4);
- hence, the frequency f_l of the limited frequency range is:

$$f_{LO} - \sum_{j=1}^{j=n} f_{Ij} - \frac{sr}{2} \leq f_l \leq f_{LO} + \sum_{j=1}^{j=n} f_{Ij} + \frac{sr}{2}$$

b) calculation of frequencies outside the limited frequency range:

- a calculation of the frequencies at which spurious responses can occur outside the range determined in a) is made for the remainder of the frequency range of interest, as appropriate (subclauses 9.7.4 and 9.7.5);
- the frequencies outside the limited frequency range are equal to the harmonics of the frequency of the local oscillator signal (f_{LO}) applied to the first mixer of the receiver plus or minus the first intermediate frequency (f_{i1}) of the receiver;
- hence, the frequencies of these spurious responses are:

$$nf_{LO} \pm f_{i1}$$

- where n is an integer greater than or equal to 2.

The measurement of the first image response of the receiver shall initially be made to verify the calculation of spurious response frequencies.

For the calculations a) and b) above, the manufacturer shall state the frequency of the receiver, the frequency of the local oscillator signal (f_{LO}) applied to the 1st mixer of the receiver, the intermediate frequencies (f_{i1} , f_{i2} etc.), and the switching range (sr) of the receiver.

9.7.3 Method of search over the "limited frequency range"

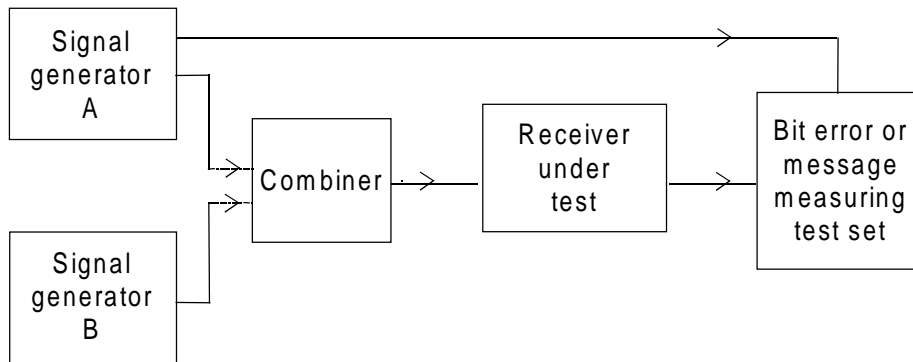

Figure 25: Measurement arrangement

The measurement procedure shall be as follows:

- a) two signal generators, A and B, shall be connected to the receiver via a combining network (subclause 7.1);

The wanted signal, provided by signal generator A, shall be at the nominal frequency of the receiver and shall have the normal test signal or modulation (subclause 7.3).

The unwanted signal, provided by signal generator B, shall be modulated with signal A-M3 (subclause 7.3).

- b) initially, signal generator B (unwanted signal) shall be switched off (maintaining the output impedance);

The level of the wanted signal from generator A shall be adjusted to the level which is 3 dB above the level of the limit of the maximum usable sensitivity as specified in subclause 9.3 (data or messages), at the receiver input terminals (i.e. 6 dB above 1 μ V emf under normal test conditions).

In the case where a continuous bit stream is used, the bit error ratio of the receiver after demodulation shall be noted.

- c) signal generator B shall then be switched on, and the level of the unwanted signal adjusted to 86 dB μ V at the receiver input terminals;

The frequency of the unwanted signal generator shall be varied in increments of 5 kHz over the limited frequency range (subclause 9.7.2 a)) and over the frequencies in accordance with the calculations outside of this frequency range (subclause 9.7.2 b)).

- d) the frequency of any spurious response detected (e.g. by an increase in the previously noted bit error ratio) during the search shall be recorded for use in the measurements in accordance with subclauses 9.7.4 and 9.7.5;
- e) in the case where operation using a continuous bit stream is not possible a similar method shall be used. In such case, instead of identifying a spurious response by noting an increase in the bit error ratio, spurious responses shall be identified by a degradation of the successful message ratio.

9.7.4 Method of measurement with continuous bit streams

The measurement shall be performed as follows, using the measurement arrangement of figure 25 in subclause 9.7.3:

- a) two signals generators, A and B, shall be connected to the receiver via a combining network (subclause 7.1);

The wanted signal, provided by signal generator A, shall be at the nominal frequency of the receiver and shall be modulated by the normal test signal D-M2 (subclause 7.3).

The unwanted signal, provided by signal generator B, shall be modulated with a frequency of 400 Hz and with a deviation of 12% of the channel separation (A-M3) (subclause 7.3), and shall be at the frequency of that spurious response being considered.

- b) initially, signal generator B (unwanted signal) shall be switched off (maintaining the output impedance);

The level of the wanted signal from generator A shall be adjusted to the level which is 3 dB above the level of the limit of the maximum usable sensitivity as specified in subclause 9.3 (data or messages), at the receiver input terminals (i.e. 6 dB above 1 μ V emf under normal test conditions).

- c) signal generator B shall then be switched on, and the level of the unwanted signal adjusted until a bit error ratio of 10^{-1} or worse is obtained;
- d) the normal test signal D-M2 shall be transmitted whilst observing the bit error ratio;
- e) the level of the unwanted signal shall be reduced in steps of 1 dB until a bit error ratio of 10^{-2} or better is obtained. The level of the unwanted signal shall then be noted;
- f) for each frequency, the spurious response rejection shall be expressed as the ratio, in dB, of the level of the unwanted signal to the level of the wanted signal, at the receiver input. This ratio shall be recorded;
- g) the measurement shall be repeated at all spurious response frequencies found during the search over the "limited frequency range" (subclause 9.7.2 a)) and at frequencies calculated for the remainder of the spurious response frequencies (subclause 9.7.2 b)) in the frequency range from $f_{Rx}/3,2$ or 30 MHz, whichever is higher, to $3,2 \times f_{Rx}$, where f_{Rx} is the nominal frequency of the receiver;
- h) the spurious response rejection of the equipment under test shall be expressed as the lowest value recorded in step f).

The limit(s) corresponding to this parameter can be found in subclause 5.2.6 .

9.7.5 Method of measurement with messages

The measurement shall be performed as follows, using the measurement arrangement of figure 25 in subclause 9.7.3:

- a) two signal generators, A and B, shall be connected to the receiver via a combining network (subclause 7.1);

The wanted signal, provided by signal generator A, shall be at the nominal frequency of the receiver and shall have normal test modulation (subclause 7.3).

The unwanted signal, provided by signal generator B, shall be modulated with a frequency of 400 Hz and with a deviation of 12% of the channel separation (A-M3) (subclause 7.3), and shall be at the frequency of that spurious response being considered.

- b) initially, signal generator B (unwanted signal) shall be switched off (maintaining the output impedance);

The level of the wanted signal from generator A shall be adjusted to the level which is 3 dB above the level of the limit of the maximum usable sensitivity as specified in subclause 9.3 (data or messages), at the receiver input terminals (i.e. 6 dB above 1 μ V emf under normal test conditions).

- c) signal generator B shall then be switched on, and the level of the unwanted signal adjusted until a successful message ratio of less than 10 % is obtained;
- d) the normal test signal (subclause 7.3) shall then be transmitted repeatedly whilst observing in each case whether or not a message is successfully received;

The level of the unwanted signal shall be reduced by 2 dB for each occasion that a message is not successfully received.

The procedure shall be continued until three consecutive messages are successfully received. The level of the input signal shall then be noted.

- e) the level of the unwanted signal shall be increased by 1 dB and the new value noted;

The normal test signal (subclause 7.3) shall then be transmitted 20 times. In each case, if a message is not successfully received the level of the unwanted signal shall be reduced by 1 dB and the new value noted.

If a message is successfully received, the level of the unwanted signal shall not be changed until three consecutive messages have been successfully received. In this case the unwanted signal shall be increased by 1 dB and the new value noted.

No level of the unwanted signal shall be noted unless preceded by a change in level.

The average of the values noted in steps d) and e) (which provides the level corresponding to the successful message ratio of 80 % shall be noted.

- f) for each frequency, the spurious response rejection shall be expressed as the ratio, in dB, of the level of the unwanted signal to the level of the wanted signal, at the receiver input. This ratio shall be recorded;
- g) the measurement shall be repeated at all spurious response frequencies found during the search over the limited frequency range, (subclause 9.7.2 a)) and at frequencies calculated for the remainder of the spurious response frequencies (subclause 9.7.2, b)) in the frequency range from $f_{Rx}/3,2$ or 30 MHz, whichever is higher, to $3,2 \times f_{Rx}$, where f_{Rx} is the nominal frequency of the receiver;
- h) the spurious response rejection of the equipment under test shall be expressed as the lowest value recorded in step f).

The limit(s) corresponding to this parameter can be found in subclause 5.2.6.

9.8 Intermodulation response rejection

9.8.1 Definition

The intermodulation response rejection is a measure of the capability of the receiver to receive a wanted modulated signal, without exceeding a given degradation due to the presence of two or more unwanted signals with a specific frequency relationship to the wanted signal frequency.

9.8.2 Method of measurement with continuous bit streams

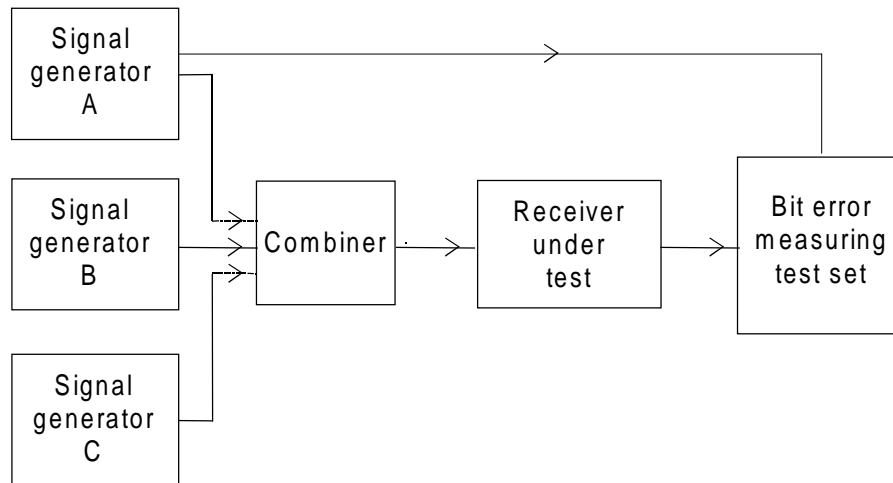

Figure 26: Measurement arrangement

The measurement procedure shall be as follows :

- a) three signal generators, A, B and C, shall be connected to the receiver via a combining network (subclause 7.1);

The wanted signal, provided by signal generator A, shall be at the nominal frequency of the receiver and shall be modulated by the normal test signal D-M2 (subclause 7.3).

The first unwanted signal, provided by signal generator B, shall be unmodulated and adjusted to a frequency 50 kHz above the nominal frequency of the receiver.

The second unwanted signal, provided by signal generator C, shall be modulated with signal A-M3 (subclause 7.3) and adjusted to a frequency 100 kHz above the nominal frequency of the receiver.

- b) initially, signal generators B and C (unwanted signals) shall be switched off (maintaining the output impedance);

The level of the wanted signal from generator A shall be adjusted to the level which is 3 dB above the level of the limit of the maximum usable sensitivity as specified in subclause 9.3 (data or messages), at the receiver input terminals (i.e. 6 dB above 1 μ V emf under normal test conditions).

- c) signal generators B and C shall then be switched on ; the levels of the two unwanted signals shall be maintained equal and shall be adjusted until a bit error ratio of 10^{-1} or worse is obtained;
- d) the normal test signal D-M2 shall then be transmitted whilst observing the bit error ratio;
- e) the level of the unwanted signals shall be reduced in steps of 1 dB until a bit error ratio of 10^{-2} or better is obtained. The level of the unwanted signals shall then be noted;
- f) for each configuration of the unwanted signals, the intermodulation response rejection shall be expressed as the ratio, in dB, of the level of the unwanted signals to the level of the wanted signal, at the receiver input. This ratio shall be recorded;
- g) the measurement shall be repeated with the unwanted signal generator B at the frequency 50 kHz below that of the wanted signal and the frequency of the unwanted signal generator C at the frequency 100 kHz below that of the wanted signal;
- h) the intermodulation response rejection of the equipment under test shall be expressed as the lower of the two values recorded in step f).

The limit(s) corresponding to this parameter can be found in subclause 5.2.7.

9.8.3 Method of measurement with messages

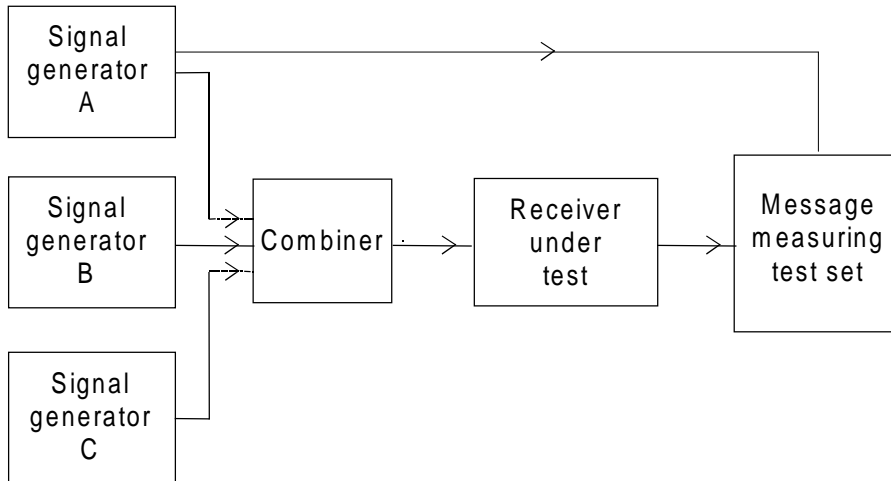

Figure 27: Measurement arrangement

The measurement procedure shall be as follows:

- a) three signal generators, A, B and C, shall be connected to the receiver via a combining network (subclause 7.1);

The wanted signal, provided by signal generator A, shall be at the nominal frequency of the receiver and shall have normal test modulation (subclause 7.3).

The first unwanted signal, provided by signal generator B, shall be unmodulated and adjusted to a frequency 50 kHz above the nominal frequency of the receiver.

The second unwanted signal, provided by signal generator C, shall be modulated with signal A-M3 (subclause 7.3) and adjusted to a frequency 100 kHz above the nominal frequency of the receiver.

- b) initially, signal generators B and C (unwanted signals) shall be switched off (maintaining the output impedance);

The level of the wanted signal from generator A shall be adjusted to the level which is 3 dB above the level of the limit of the maximum usable sensitivity as specified in subclause 9.3 (data or messages), at the receiver input terminals (i.e. 6 dB above 1 μ V emf under normal test conditions).

- c) signal generators B and C shall then be switched on; the levels of the two unwanted signals shall be maintained equal and shall be adjusted until a successful message ratio of less than 10 % is obtained;

- d) the normal test signal (subclause 7.3) shall then be transmitted repeatedly whilst observing in each case whether or not a message is successfully received;

The levels of the unwanted signals shall be reduced by 2 dB for each occasion that a message is not successfully received.

The procedure shall be continued until three consecutive messages are successfully received. The level of the input signals shall then be noted.

- e) the level of the unwanted signals shall be increased by 1 dB and the new value noted;

The normal test signal (subclause 7.3) shall then be transmitted 20 times. In each case, if a message is not successfully received the level of the unwanted signals shall be reduced by 1 dB and the new value noted.

If a message is successfully received, the level of the unwanted signals shall not be changed until three consecutive messages have been successfully received. In this case the unwanted signals shall be increased by 1 dB and the new value noted.

No level of the unwanted signals shall be noted unless preceded by a change in level.

The average of the values noted in steps d) and e) (which provides the level corresponding to the successful message ratio of 80 %) shall be noted.

- f) for each configuration of the unwanted signals, the intermodulation response rejection shall be expressed as the ratio, in dB, of the average level noted in step e) to the level of the wanted signal, at the receiver input. This ratio shall be recorded;
- g) the measurement shall be repeated with the unwanted signal generator B at the frequency 50 kHz below that of the wanted signal and the frequency of the unwanted signal generator C at the frequency 100 kHz below that of the wanted signal;
- h) the intermodulation response rejection of the equipment under test shall be expressed as the lower of the two values recorded in step f).

The limit(s) corresponding to this parameter can be found in subclause 5.2.7.

9.9 Blocking or desensitisation

9.9.1 Definition

Blocking is a measure of the capability of the receiver to receive a wanted modulated signal without exceeding a given degradation due to the presence of an unwanted input signal at any frequencies other than those of the spurious responses or the adjacent channels.

9.9.2 Method of measurement with continuous bit streams

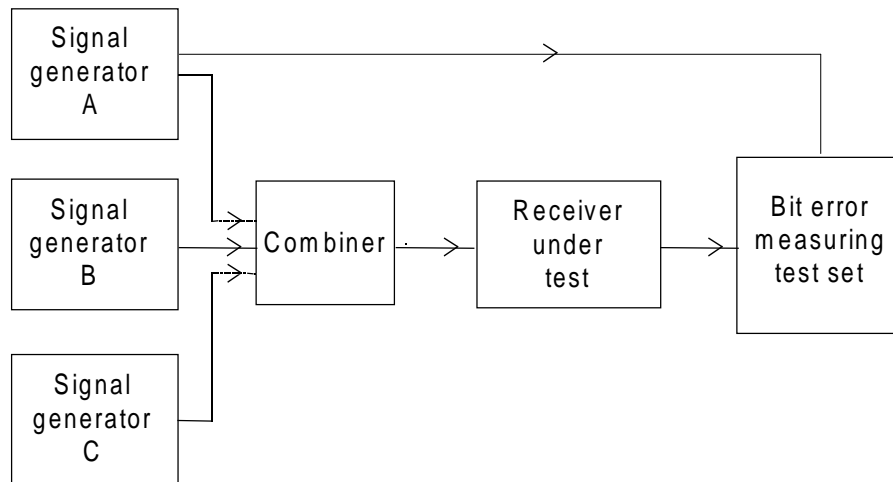

Figure 28: Measurement arrangement

The measurement procedure shall be as follows:

- a) two signal generators, A and B, shall be connected to the receiver via a combining network (subclause 7.1);

The wanted signal, provided by signal generator A, shall be at the nominal frequency of the receiver and shall be modulated by the normal test signal D-M2 (subclause 7.3).

The unwanted signal, provided by signal generator B, shall be unmodulated and shall be at a frequency from 1 MHz to 10 MHz away from the nominal frequency of the receiver.

For practical reasons the measurements shall be carried out at frequencies of the unwanted signal at approximately ± 1 MHz, ± 2 MHz, ± 5 MHz and ± 10 MHz, avoiding those frequencies at which spurious responses could occur (subclause 9.7).

- b) initially, signal generator B (unwanted signal) shall be switched off (maintaining the output impedance);

The level of the wanted signal from generator A shall be adjusted to the level which is 3 dB above the level of the limit of the maximum usable sensitivity as specified in subclause 9.3 (data or messages), at the receiver input terminals (i.e. 6 dB above 1 μ V emf under normal test conditions).

- c) signal generator B shall then be switched on, and the level of the unwanted signal adjusted until a bit error ratio of 10^{-1} or worse is obtained;
- d) the normal test signal D-M2 shall be transmitted whilst observing the bit error ratio;
- e) the level of the unwanted signal shall be reduced in steps of 1 dB until a bit error ratio of 10^{-2} or better is obtained. The level of the unwanted signal shall then be noted;
- f) for each frequency, the blocking or desensitisation shall be expressed as the ratio, in dB, of the level of the unwanted signal to the level of the wanted signal, at the receiver input. This ratio shall be recorded;
- g) the measurement shall be repeated for all the frequencies defined in step a);
- h) the blocking or desensitisation of the equipment under test shall be expressed as the lowest of the values recorded in step f).

The limit(s) corresponding to this parameter can be found in subclause 5.2.8.

9.9.3 Method of measurement with messages

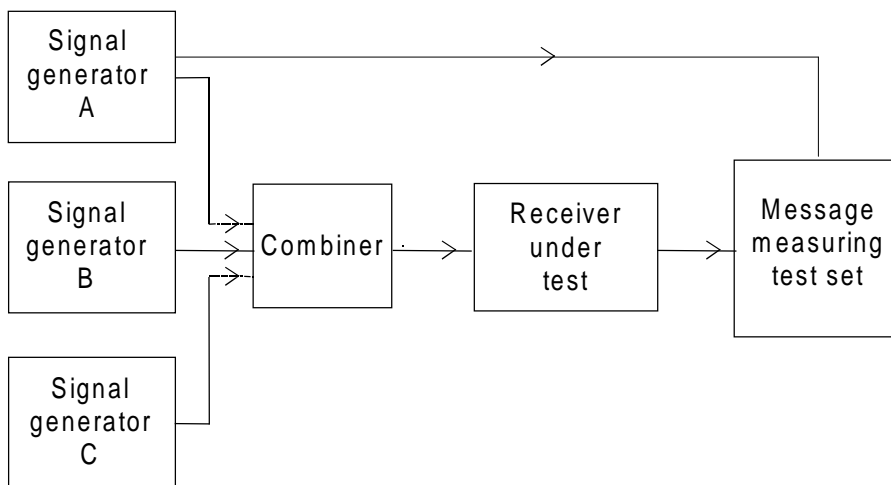

Figure 29: Measurement arrangement

The measurement procedure shall be as follows:

- a) two signal generators, A and B, shall be connected to the receiver via a combining network (subclause 7.1);

The wanted signal, provided by signal generator A, shall be at the nominal frequency of the receiver and shall have normal test modulation (subclause 7.3).

The unwanted signal, provided by signal generator B, shall be unmodulated and shall be at a frequency from 1 MHz to 10 MHz away from the nominal frequency of the receiver.

For practical reasons the measurements shall be carried out at frequencies of the unwanted signal at approximately ± 1 MHz, ± 2 MHz, ± 5 MHz and ± 10 MHz, avoiding those frequencies at which spurious responses could occur (subclause 9.7).

- b) initially, signal generator B (unwanted signal) shall be switched off (maintaining the output impedance);

The level of the wanted signal from generator A shall be adjusted to the level which is 3 dB above the level of the limit of the maximum usable sensitivity as specified in subclause 9.3 (data or messages) at the receiver input terminals (i.e. 6 dB above 1 μ V emf under normal test conditions).

- c) signal generator B shall then be switched on, and the level of the unwanted signal adjusted until a successful message ratio of less than 10 % is obtained;
- d) the normal test signal (subclause 7.3) shall then be transmitted repeatedly whilst observing in each case whether or not a message is successfully received;

The level of the unwanted signal shall be reduced by 2 dB for each occasion that a message is not successfully received.

The procedure shall be continued until three consecutive messages are successfully received. The level of the input signal shall then be noted.

- e) the level of the unwanted signal shall be increased by 1 dB and the new value noted;

The normal test signal (subclause 7.3) shall then be transmitted 20 times. In each case, if a message is not successfully received the level of the unwanted signal shall be reduced by 1 dB and the new value noted.

If a message is successfully received, the level of the unwanted signals shall not be changed until three consecutive messages have been successfully received. In this case the unwanted signal shall be increased by 1 dB and the new value noted.

No level of the unwanted signal shall be noted unless preceded by a change in level.

The average of the values noted in steps d) and e) (which provides the level corresponding to the successful message ratio of 80 %) shall be noted.

- f) for each frequency, the blocking or desensitisation shall be expressed as the ratio, in dB, of the level of the unwanted signal to the level of the wanted signal, at the receiver input. This ratio shall be recorded;
- g) the measurement shall be repeated for all the frequencies defined in step a);
- h) the blocking or desensitisation of the equipment under test shall be expressed as the lowest of the values recorded in step f).

The limit(s) corresponding to this parameter can be found in subclause 5.2.8.

9.10 Spurious radiations

9.10.1 Definition

Spurious radiations from the receiver are emissions at any frequency, radiated by the equipment and its antenna.

The level of spurious radiations shall be measured by:

either

- a) their power level in a specified load (conducted spurious emission); and

- b) their effective radiated power when radiated by the cabinet and structure of the equipment (cabinet radiation); or
- c) their effective radiated power when radiated by the cabinet and by the integral antenna, in the case of hand portable equipment fitted with such an antenna and no external RF connector.

9.10.2 Method of measuring the power level

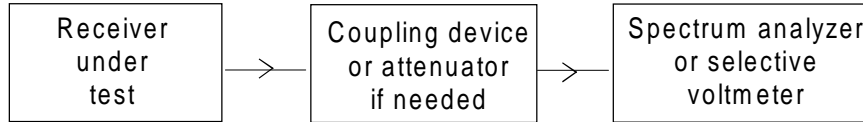

Figure 30: Measurement arrangement

This method applies only to equipment having an external antenna connector.

Spurious radiations shall be measured as the power level of any discrete signal at the input terminals of the receiver. The receiver input terminals are connected to a spectrum analyzer or selective voltmeter having an input impedance of 50 Ω and the receiver is switched on.

If the detecting device is not calibrated in terms of power input, the level of any detected components shall be determined by a substitution method using a signal generator.

The measurements shall extend, for equipment operating on frequencies not exceeding 470 MHz, over the frequency range of 9 kHz to 4 GHz, and in addition shall be repeated over the frequency range 4 GHz to 12,75 GHz for equipment operating on frequencies above 470 MHz.

The limit(s) corresponding to this parameter can be found in subclause 5.2.9.

9.10.3 Method of measuring the effective radiated power

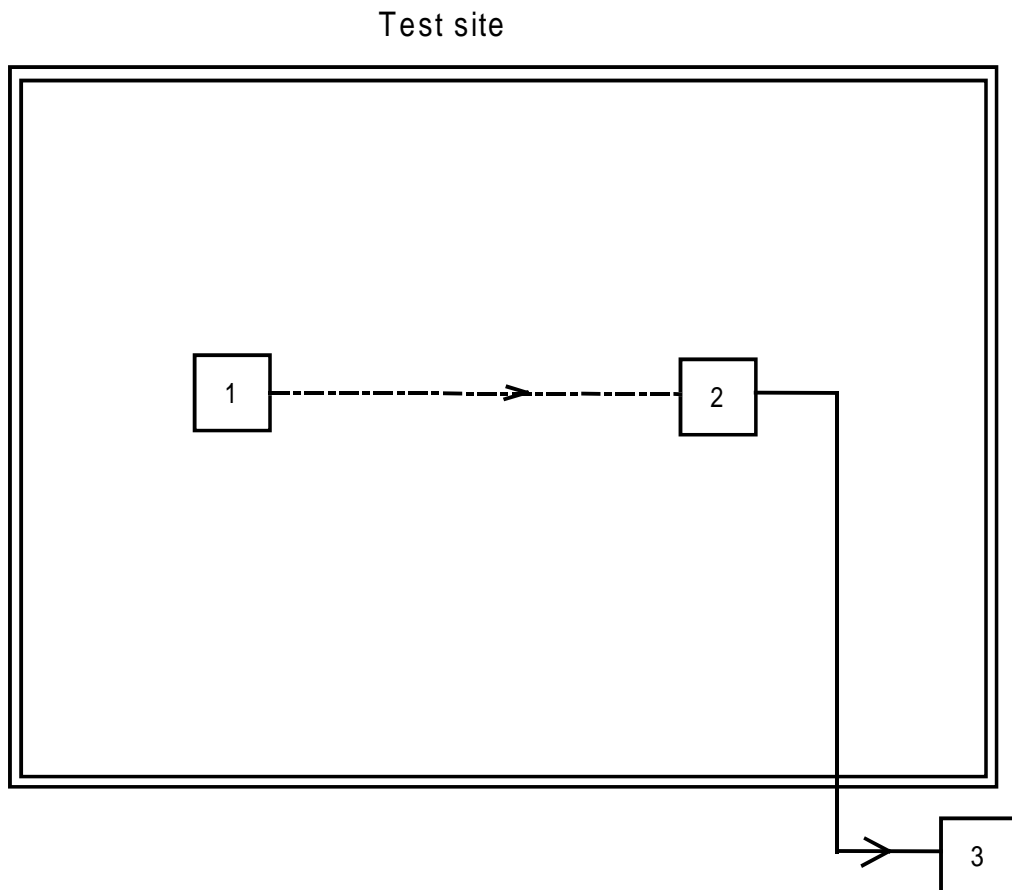

- 1) receiver under test
- 2) test antenna
- 3) spectrum analyzer or selective voltmeter (test receiver)

Figure 31: Measurement arrangement

The measurement procedure shall be as follows:

- a) on a test site, fulfilling the requirements of clause A.2, the sample shall be placed at the specified height on the non-conducting support. The receiver shall be operated from a power source via a radio frequency filter to avoid radiation from the power leads;
- b) the receiver shall be connected:
 - to an artificial antenna (subclause 7.7) for equipment having an external antenna connector (subclause 9.10.1 b)); or
 - to the integral antenna (subclause 9.10.1 c));
- c) radiation of any spurious components shall be detected by the test antenna and receiver, over the frequency range 30 MHz to 4 GHz;

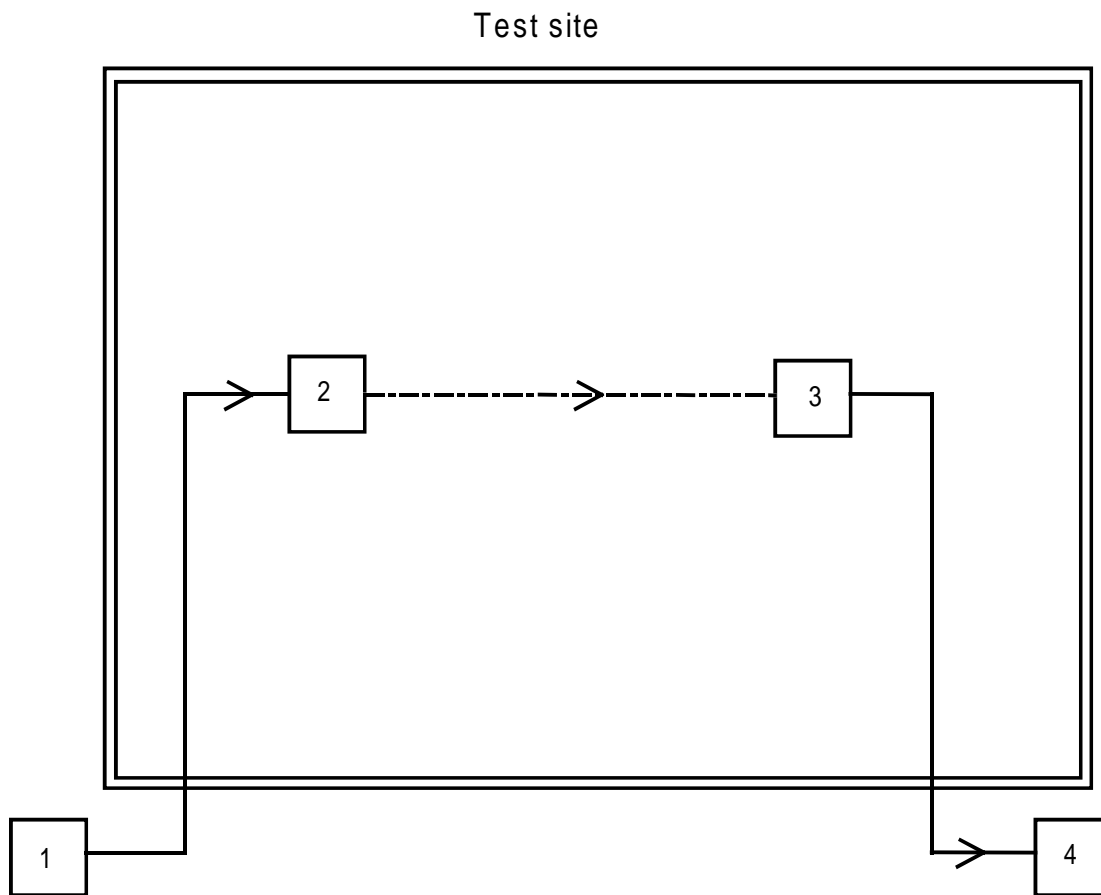

- 1) signal generator
- 2) substitution antenna
- 3) test antenna
- 4) spectrum analyzer or selective voltmeter (test receiver)

Figure 32: Measurement arrangement

- d) at each frequency at which a component is detected, the sample shall be rotated to obtain maximum response and the effective radiated power of that component determined by a substitution measurement, using the measurement arrangement of figure 32;
- e) the measurement shall be repeated with the test antenna in the orthogonal polarisation plane.

The limit(s) corresponding to this parameter can be found in subclause 5.2.9.

10 Duplex operation

If the equipment is designed for duplex operation, when submitted for type testing it shall be fitted with a duplex filter and the following additional measurements shall be carried out to ensure satisfactory duplex operation.

Duplex measurements shall be carried out on a single pair of frequencies only, as specified by the manufacturer/applicant in consultation with the appropriate Administration.

10.1 Receiver desensitisation (with simultaneous transmission and reception)

10.1.1 Definition

The desensitisation is the degradation of the sensitivity of the receiver resulting from the transfer of power from the transmitter to the receiver due to coupling effects. It is expressed as the difference in dB between the maximum usable sensitivity levels (data or messages, conducted), with and without simultaneous transmissions.

10.1.2 Desensitisation measured with continuous bit streams

10.1.2.1 Method of measurement when the equipment has a duplex filter

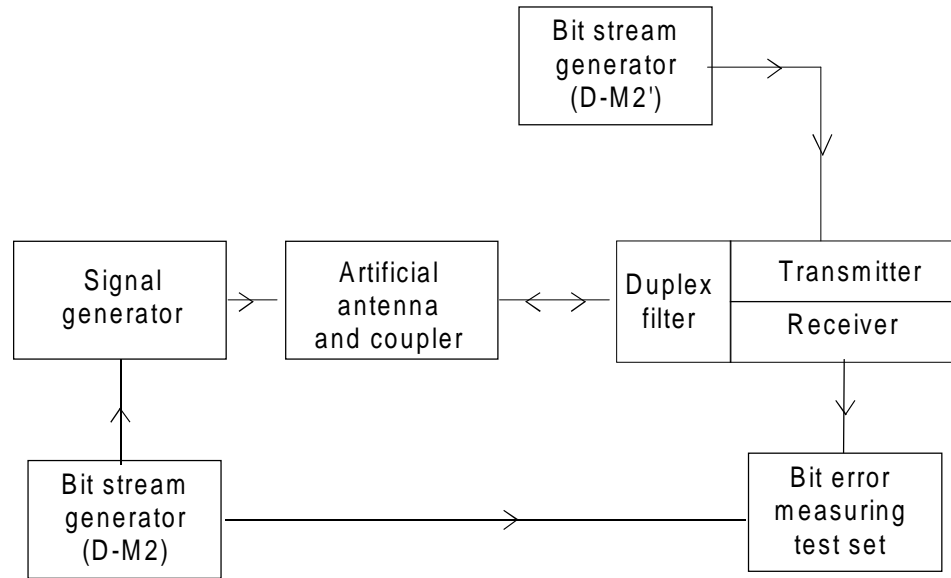

Figure 33: Measurement arrangement

The measurement procedure shall be as follows:

- a) the antenna terminal of the equipment comprising of the receiver, transmitter and duplex filter, shall be connected through a coupling device to the artificial antenna specified in subclause 7.7;

A signal generator modulated by the normal test signal D-M2 (subclause 7.3), shall be connected to the coupling device so that it does not affect the impedance matching and does not generate intermodulation products which could impair the results of the measurement.

- b) the transmitter shall be brought into operation at the carrier output power as defined in subclause 8.2, modulated by the normal test signal D-M2' (subclause 7.3);

The receiver sensitivity (data, conducted) shall then be measured in accordance with subclause 9.1.2.

- c) the output level of the signal generator shall be noted as C in dB relative to an emf of 1 μ V;
- d) the transmitter shall then be switched off and the receiver sensitivity (data, conducted) is measured again;
- e) the output level of the signal generator shall be noted as D in dB relative to an emf of 1 μ V;
- f) the desensitisation is the difference between the values of C and D in dB.

The limit(s) corresponding to this parameter can be found in subclause 5.3.1.

10.1.2.2 Method of measurement when the equipment has to operate with two antennas

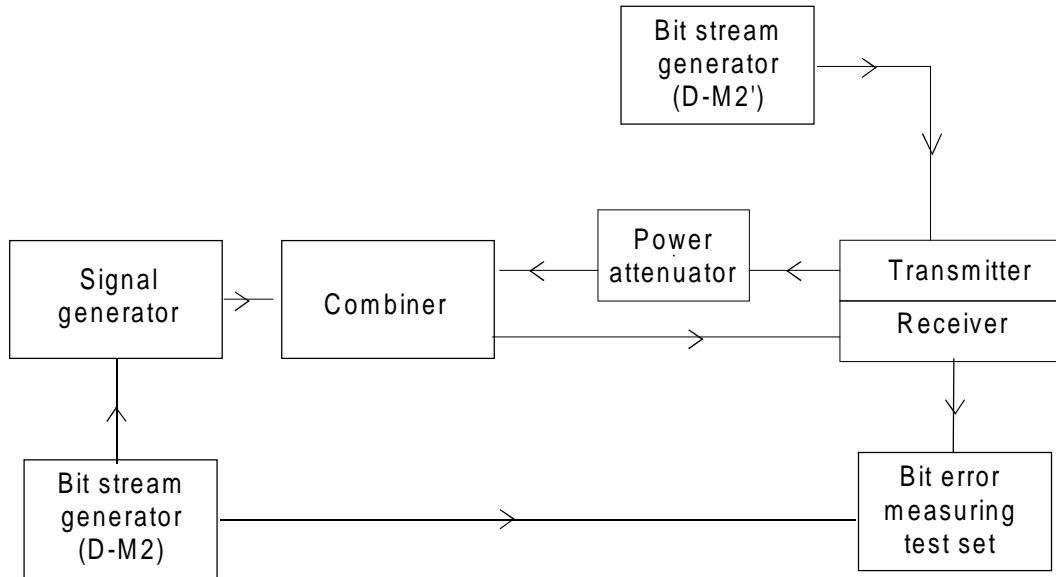

Figure 34: Measurement arrangement

The measurement procedure shall be as follows:

- a) the transmitter shall be connected to a power attenuator (in order to dissipate the nominal RF output power of the transmitter) the rating of which shall be declared by the manufacturer;

The attenuator output shall be connected to the receiver input by means of a coupling device and a filter, if the latter is part of the standard equipment. The total attenuation between transmitter and receiver shall be 30 dB.

A signal generator modulated by the normal test signal D-M2 (subclause 7.3) shall be connected to the coupling device in such a way as not to affect the impedance matching and does not generate intermodulation products which could impair the results of the measurement.

- b) the transmitter shall be brought into operation with an output power as defined in subclause 8.2, modulated by the normal test signal D-M2' (subclause 7.3);

The receiver sensitivity (data, conducted) shall then be measured in accordance with subclause 9.1.2.

- c) the output level of the signal generator shall be noted as C in dB relative to an emf of 1 μ V;
- d) the transmitter shall then be switched off and the receiver sensitivity (data, conducted) measured again;
- e) the output level of the signal generator shall be noted as D in dB relative to an emf of 1 μ V;
- f) the desensitisation is the difference between the values of C and D in dB.

The limit(s) corresponding to this parameter can be found in subclause 5.3.1.

10.1.3 Desensitisation measured with messages

10.1.3.1 Method of measurement when the equipment has a duplex filter

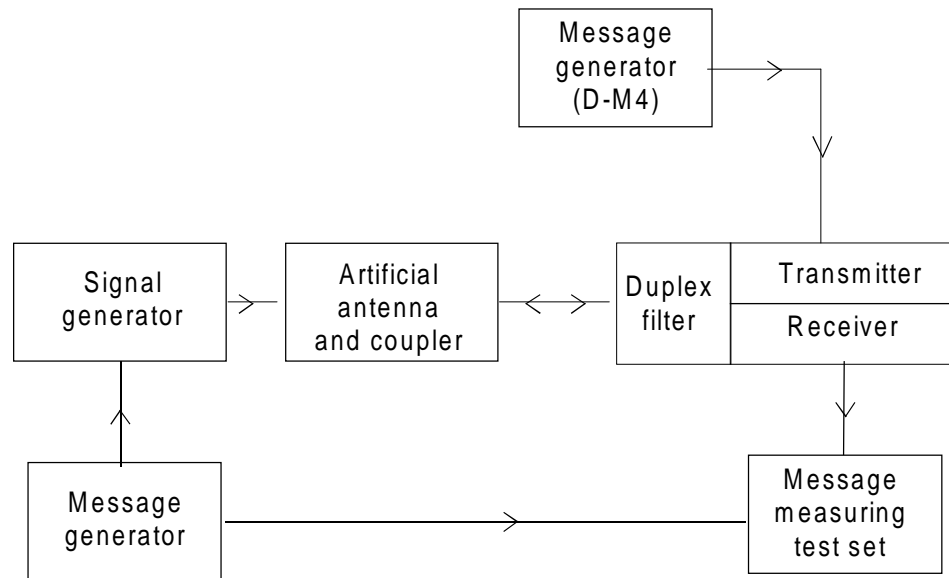

Figure 35: Measurement arrangement

The measurement procedure shall be as follows:

- a) the antenna terminal of the equipment comprising of the receiver, transmitter and duplex filter, shall be connected through a coupling device to the artificial antenna specified in subclause 7.7;

A signal generator having normal test modulation (subclause 7.3) shall be connected to the coupling device so that it does not affect the impedance matching and does not generate intermodulation products which could impair the results of the measurement.

- b) the transmitter shall be brought into operation with an output power as defined in subclause 8.2, and shall be modulated by the normal test signal D-M4 (subclause 7.3), using a message different from the message used in step a);

The receiver sensitivity (messages, conducted) shall then be measured in accordance with subclause 9.1.3.

- c) the output level of the signal generator shall be noted as C in dB relative to an emf of 1 μ V;
- d) the transmitter shall then be switched off and the receiver sensitivity (messages, conducted) measured again;
- e) the output level of the signal generator shall be noted as D in dB relative to an emf of 1 μ V;
- f) the desensitisation is the difference between the values of C and D in dB.

The limit(s) corresponding to this parameter can be found in subclause 5.3.1.

10.1.3.2 Method of measurement when the equipment has to operate with two antennas

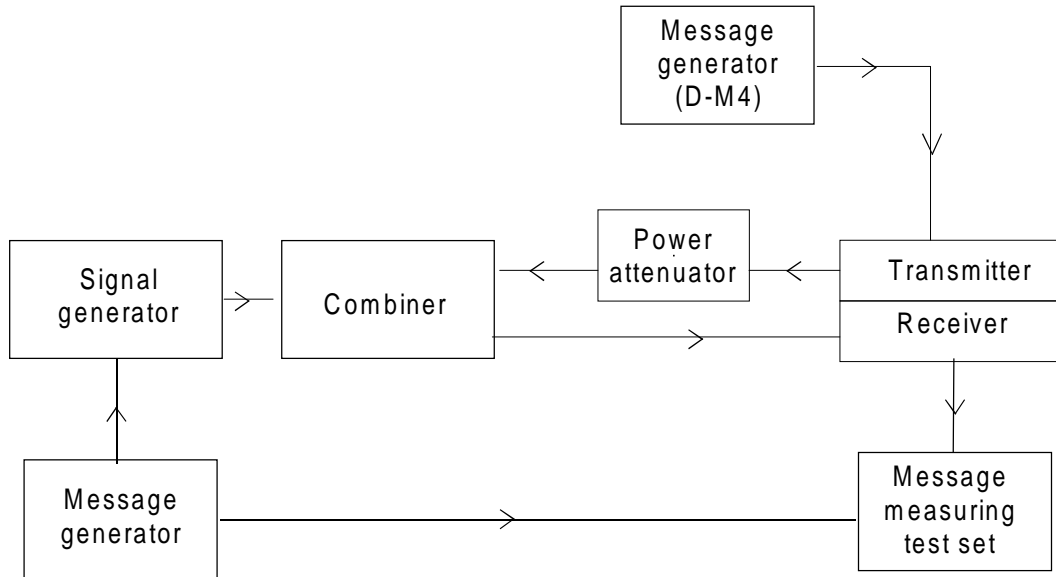

Figure 36: Measurement arrangement

The measurement procedure shall be as follows:

- a) the transmitter shall be connected to a power attenuator (in order to dissipate the nominal RF output power of the transmitter) the rating of which shall be declared by the manufacturer;

The attenuator output shall be connected to the receiver input by means of a coupling device and a filter, if the latter is part of the standard equipment. The total attenuation between transmitter and receiver shall be 30 dB.

A signal generator having normal test modulation (subclause 7.3) shall be connected to the coupling device so that it does not affect the impedance matching and does not generate intermodulation products which could impair the results of the measurement.

- b) the transmitter shall be brought into operation with an output power as defined in subclause 8.2, and shall be modulated by the normal test signal D-M4 (subclause 7.3) using a message different from the message used in step a);

The receiver sensitivity (messages, conducted) shall then be measured in accordance with subclause 9.1.3.

- c) the output level of the signal generator shall be noted as C in dB relative to an emf of 1 μ V;
- d) the transmitter shall then be switched off and the receiver sensitivity (messages, conducted) measured again;
- e) the output level of the signal generator shall be noted as D in dB relative to an emf of 1 μ V;
- f) the desensitisation is the difference between the values of C and D in dB.

The limit(s) corresponding to this parameter can be found in subclause 5.3.1.

10.2 Receiver spurious response rejection (with simultaneous transmission and reception)

10.2.1 Definition

The spurious response rejection, under duplex operation, is a measure of the capability of the receiver to achieve a specific spurious response rejection ratio when receiving a wanted modulated signal in the presence of:

- a) an unwanted signal at any other frequency, at which a response may be obtained; and
- b) the unmodulated signal of the transmitter operating at duplex frequency distance, at the rated output power and attenuated by the duplex filter or by the distance between the antennas.

10.2.2 Method of measurement

The receiver spurious response rejection under duplex operation shall be measured as specified in subclause 9.7 with the measurement arrangement described in subclauses 10.1.2 or 10.1.3, except that the transmitter shall be unmodulated. The transmitter shall be operated at the carrier output power as defined in subclause 8.2.

The measurement shall be performed around frequencies f_m derived from the expressions:

$$(p)f_t + (q)f_m = f_r \text{ and } f_m = (n)f_t \pm f_{i1};$$

where:

f_t is the transmitter frequency;

f_r is the receiver frequency; and

f_{i1} is the first IF of the receiver.

$$n = \geq 2$$

Particular attention should be made to the following values:

$$(p) = -1, (q) = 2 \text{ and } (p) = 2, (q) = -1.$$

It should be noted that the method of measurement described may cause errors at certain frequencies due to the effect of signal generator intermodulation. To overcome such errors, a band stop filter at the transmitting frequency may be used, in conjunction with the signal generator combining network.

The limit(s) corresponding to this parameter can be found in subclause 5.3.2.

11 Measurement uncertainty

Table 9: Absolute measurement uncertainties: maximum values

Parameter	Uncertainty
Radio Frequency	$\pm 1 \times 10^{-7}$
RF Power (up to 160 W)	$\pm 0,75$ dB
Radiated RF power	± 6 dB
Adjacent channel power	± 5 dB
Conducted spurious emission of transmitter valid up to 12,75 GHz	± 4 dB
Conducted spurious emission of receiver, valid up to 12,75 GHz	± 3 dB
Two-signal measurement, valid up to 4 GHz	± 4 dB
Three-signal measurement	± 3 dB
Radiated emission of the transmitter, valid up to 4 GHz	± 6 dB
Radiated emission of receiver, valid up to 4 GHz	± 6 dB
Transmitter attack time	± 20 %
Transmitter release time	± 20 %
Transmitter transient frequency (frequency difference)	± 250 Hz
Transmitter intermodulation	± 3 dB
Receiver desensitisation (duplex operation)	$\pm 0,5$ dB
Valid up to 1 GHz for the RF parameters unless otherwise stated.	

For the test methods according to this ETS, these uncertainty figures are valid to a confidence level of 95 % calculated according to the methods described in ETR 028 [4].

Annex A (normative): Radiated measurements

A.1 Test site and general arrangements for measurements involving the use of radiated fields

A.1.1 Test site

The test site shall be on a reasonably level surface or ground. At one point on the site, a ground plane of at least 5 m diameter shall be provided. In the middle of this ground plane, a non-conducting support, capable of rotation through 360° in the horizontal plane, shall be used to support the test sample at 1,5 m above the ground plane. The test site shall be large enough to allow the erection of a measuring or transmitting antenna at a distance of $\lambda/2$ or 3 m, whichever is the greater. The distance actually used shall be recorded with the results of the tests carried out on the site.

Sufficient precautions shall be taken to ensure that reflections from extraneous objects adjacent to the site and ground reflections do not degrade the measurements results.

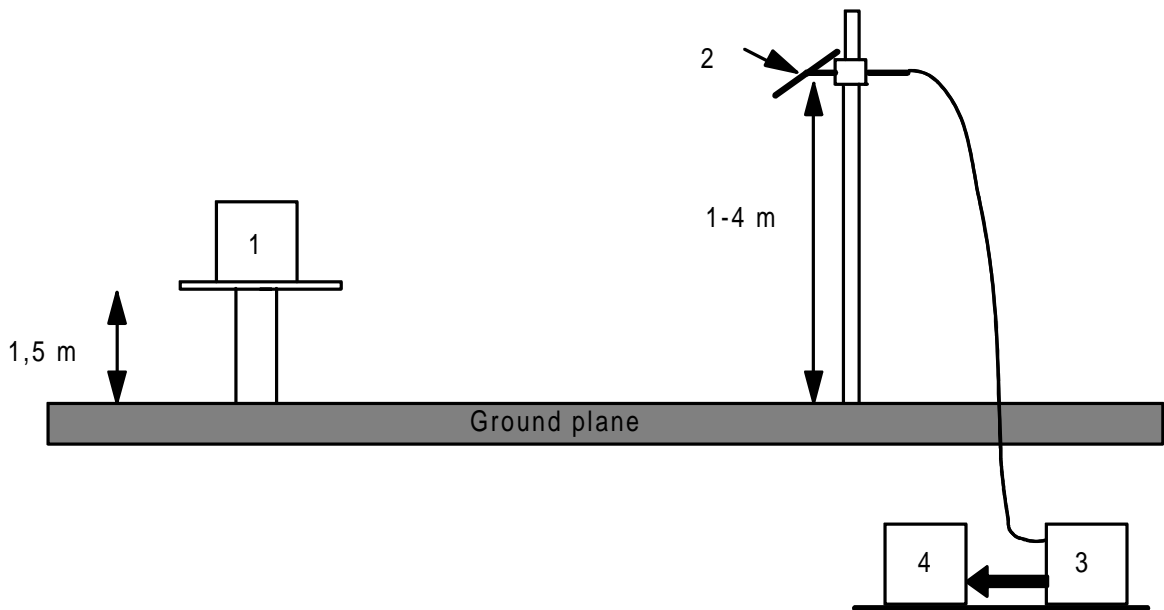

Legend:

- 1) equipment under test
- 2) test antenna
- 3) high pass filter (necessary for strong fundamental Tx radiation)
- 4) spectrum analyzer or measuring receiver

Figure A.1: Test site

A.1.2 Test antenna

The test antenna is used to detect the radiation from both the test sample and the substitution antenna, when the site is used for radiation measurements; where necessary, it is used as a transmitting antenna, when the site is used for the measurement of receiver characteristics.

This antenna is mounted on a support such as to allow the antenna to be used in either horizontal or vertical polarisation and for the height of its centre above ground to be varied over the range 1 to 4 m. Preferably a test antenna with pronounced directivity should be used. The size of the test antenna along the measurement axis shall not exceed 20 % of the measuring distance.

For receiver and transmitter radiation measurements, the test antenna is connected to a measuring receiver, capable of being tuned to any frequency under investigation, and of measuring accurately the relative levels of signals at its input. For receiver radiated sensitivity measurements the test antenna is connected to a signal generator.

A.1.3 Substitution antenna

When measuring in the frequency range up to 1 GHz the substitution antenna shall be a $\lambda/2$ dipole, resonant at the frequency under consideration, or a shortened dipole, calibrated to a $\lambda/2$ dipole. When measuring in the frequency range above 4 GHz a horn radiator shall be used. For measurements between 1 and 4 GHz either a $\lambda/2$ dipole or a horn radiator may be used. The centre of this antenna shall coincide with the reference point of the test sample it has replaced. This reference point shall be the volume centre of the sample when its antenna is mounted inside the cabinet, or the point where an external antenna is connected to the cabinet.

The distance between the lower extremity of the dipole and the ground shall be at least 0,3 m.

The substitution antenna shall be connected to a calibrated signal generator when the site is used for spurious radiation measurements and transmitter effective radiated power measurements. The substitution antenna shall be connected to a calibrated measuring receiver when the site is used for the measurement of receiver sensitivity.

The signal generator and the receiver shall be operated at the frequencies under investigation and shall be connected to the antenna through suitable matching and balancing networks.

NOTE: The gain of a horn antenna is generally expressed relative to an isotropic radiator by the horn manufacturer's data. This data should be corrected and referenced to that of a $\lambda/2$ dipole. It is assumed that the gain of a $\lambda/2$ dipole relative to an isotropic radiator is + 2,2 dBi.

Therefore, the calculation is as follows:

$$\text{erp} = \text{Ps} - \text{C} + \text{A},$$

where:

- Ps = Power level of the signal generator;
- C = Coaxial cable loss (signal generator to antenna);
- A = Antenna gain (relative to $\lambda/2$ dipole) = dBd;
- dBd = dBi - 2,2.

A.1.4 Optional additional indoor site

When the frequency of the signal being measured is greater than 80 MHz, use may be made of an indoor site. If this alternative site is used, this shall be recorded in the test report.

The measurement site may be a laboratory room with a minimum area of 6 m by 7 m and at least 2,7 m in height.

Apart from the measuring apparatus and the operator, the room shall be as free as possible from reflecting objects other than the walls, floor and ceiling.

The potential reflections from the wall behind the equipment under test are reduced by placing a barrier of absorbent material in front of it. The corner reflector around the test antenna is used to reduce the effect of reflections from the opposite wall and from the floor and ceiling in the case of horizontally polarised measurements. Similarly, the corner reflector reduces the effects of reflections from the side walls for vertically polarised measurements. For the lower part of the frequency range (below approximately 175 MHz) no corner reflector or absorbent barrier is needed. For practical reasons, the $\lambda/2$ antenna in figure A.2 may be replaced by an antenna of constant length, provided that this length is between $\lambda/4$ and λ at the frequency of measurement and the sensitivity of the measuring system is sufficient. In the same way the distance of $\lambda/2$ to the apex may be varied.

The test antenna, measuring receiver, substitution antenna and calibrated signal generator are used in a way similar to that of the general method.

To ensure that errors are not caused by the propagation path approaching the point at which phase cancellation between direct and the remaining reflected signals occurs, the substitution antenna shall be moved through a distance of $\pm 0,10$ m in the direction of the test antenna as well as in the two directions perpendicular to this first direction.

If these changes of distance cause a signal change of greater than 2 dB, the test sample shall be re-sited until a change of less than 2 dB is obtained.

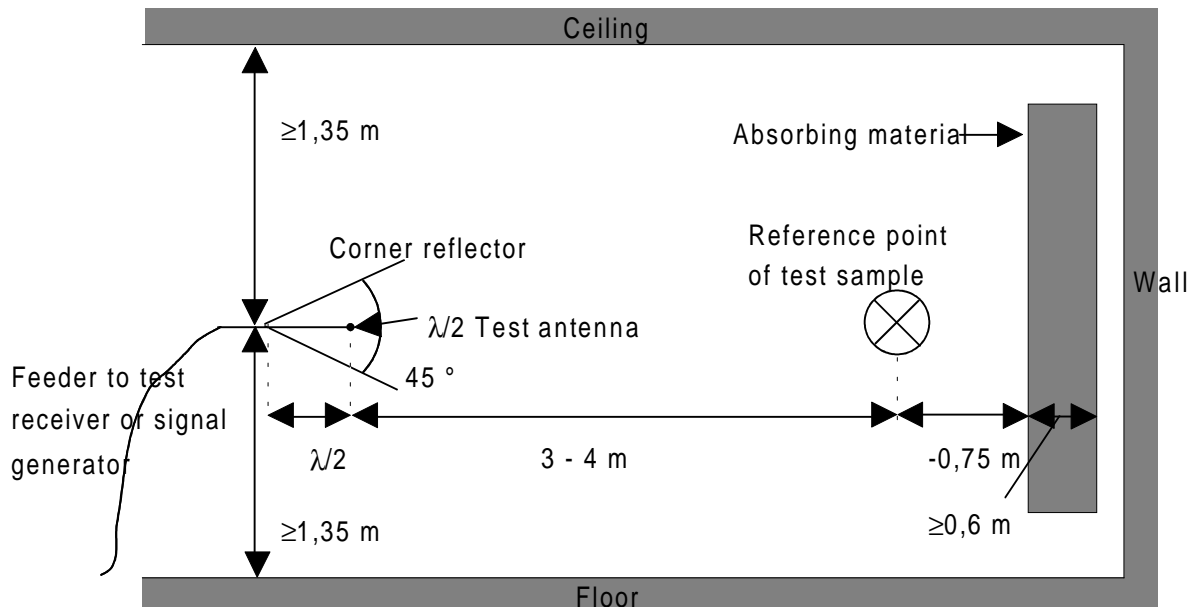

Figure A.2: Indoor site arrangement (shown for horizontal polarisation).

A.2 Guidance on the use of radiation test sites

For measurements involving the use of radiated fields, use may be made of a test site in conformity with the requirements of clause A.1. When using such a test site, the following conditions should be observed to ensure consistency of measuring results.

A.2.1 Measuring distance

Evidence indicates that the measuring distance is not critical and does not significantly affect the measuring results, provided that the distance is not less than $\lambda/2$ at the frequency of measurement and the precautions described in this annex are observed. Measuring distances of 3 m, 5 m, 10 m and 30 m are in common use in European test laboratories.

A.2.2 Test antenna

Different types of test antenna may be used, since performing substitution measurements reduces the effect of the errors on the measuring results.

Height variation of the test antenna over a range of 1 to 4 m is essential in order to find the point at which the radiation is a maximum.

Height variation of the test antenna may not be necessary at the lower frequencies, below approximately 100 MHz.

A.2.3 Substitution antenna

Variations in the measuring results may occur with the use of different types of substitution antenna at the lower frequencies, below approximately 80 MHz.

Where a shortened dipole antenna is used at these frequencies, details of the type of antenna used shall be included with the results of the tests carried out on the site. Correction factors shall be taken into account when shortened dipole antennas are used.

A.2.4 Artificial antenna

The dimensions of the artificial antenna used during radiated measurements should be small in relation to the sample under test.

Where possible, a direct connection shall be used between the artificial antenna and the test sample.

In cases where it is necessary to use a connecting cable, precautions shall be taken to reduce the radiation from this cable by, for example, the use of ferrite cores or double screened cables.

A.2.5 Auxiliary cables

The position of auxiliary cables (power supply and microphone cables, etc.) which are not adequately decoupled may cause variations in the measuring results. In order to get reproducible results, cables and wires of auxiliaries shall be arranged vertically downwards (through a hole in the non conducting support).

A.2.6 Acoustic measuring arrangement

When carrying out measurements of the maximum usable sensitivity (radiated) of the receiver, the audio output shall be monitored by acoustically coupling the audio signal from the receiver loudspeaker/transducer to the test microphone. On the radiation test site, all conducting materials shall be placed below the ground surface and the acoustic signal conveyed from the receiver to the test microphone via a non-conducting acoustic pipe.

The acoustic pipe shall have an appropriate length, an inner diameter of 6 mm and a wall thickness of 1,5 mm. A plastic funnel of a diameter corresponding to the receiver loudspeaker/transducer shall be attached to the receiver surface centred in front of the receiver loudspeaker/transducer. The plastic funnel shall be very soft at the attachment point to the receiver in order to avoid mechanical resonance. The narrow end of the plastic funnel shall be connected to the one end of the acoustic pipe and the test microphone to the other.

A.3 Further optional alternative indoor site using an anechoic chamber

For radiation measurements when the frequency of the signals being measured is greater than 30 MHz, use may be made of an indoor site consisting of a well-shielded anechoic chamber simulating a free space environment. If such a chamber is used, this shall be recorded in the test report.

The test antenna, test receiver, substitution antenna and calibrated signal generator shall be used in a way similar to that of the general method, given in clause A.1. In the range between 30 MHz to 100 MHz some additional calibration may be necessary.

An example of a typical measurement site may be an electrically shielded anechoic chamber being 10 m long, 5 m broad and 5 m high.

Walls and ceiling are coated with RF absorbers of 1 m height.

The base is covered with absorbing material 1 m thick, and a wooden floor, able to carry test equipment and operators.

A measuring distance of 3 to 5 m in the long middle axis of the chamber can be used for measurements up to 12,75 GHz. The construction of the anechoic chamber is described in the following subclauses.

A.3.1 Example of the construction of a shielded anechoic chamber

Free-field measurements can be simulated in a shielded measuring chamber where the walls are coated with RF absorbers.

Figure A.3 shows the requirements for shielding loss and wall return loss of such a room.

As dimensions and characteristics of usual absorber materials are critical below 100 MHz (height of absorbers < 1 m, reflection attenuation < 20 dB) such a room is preferably suitable for measurements above 100 MHz.

Figure A.4 shows the construction of a shielded measuring chamber having a base area of 5 m by 10 m and a height of 5 m.

Ceilings and walls are coated with pyramidal formed RF absorbers approximately 1 m high. The base is covered with absorbers above which is constructed a non-conducting sub-floor, or with special ground floor absorbers.

The available internal dimensions of the room are 3 m by 8 m by 3 m, so that a measuring distance of maximum 5 m length in the middle axis of this room is available.

At 100 MHz the measuring distance can be extended up to a maximum of 2 wavelengths.

The floor absorbers reject floor reflections so that the antenna height need not be changed and floor reflection influences need not be considered.

All measuring results can therefore be checked with simple calculations and the measuring tolerances have the smallest possible values due to the simple measuring configuration.

For special measurements it would be necessary to re-introduce floor reflections. Therefore the floor absorbers are covered with metal plates or metallic nets instead.

A.3.2 Influence of parasitic reflections in anechoic chambers

For free-space propagation in the far field the correlation $E=E_0(R_0/R)$ is valid for the dependence of the field strength E on the distance R , whereby E_0 is the reference field strength at the reference distance R_0 .

It is useful to use just this correlation for comparison measurements, as all constants are eliminated with the ratio and neither cable attenuation, nor antenna mismatch, nor antenna dimensions are of importance.

Deviations from the ideal curve can be seen easily if the logarithm of the above equation is used, because the ideal correlation of field strength and distance can then be shown as a straight line and the deviations occurring in practice are clearly visible. This indirect method shows the disturbances due to reflections more readily and is far less problematical than the direct measurement of reflection attenuation.

With an anechoic chamber of the dimensions suggested in clause A.3 at low frequencies up to 100 MHz there are no far field conditions, and therefore reflections are stronger so that careful calibration is necessary.

In the medium frequency range from 100 MHz to 1 GHz the dependence of the field strength on the distance meets the expectations very well.

In the frequency range of 1 GHz to 12,75 GHz, because more reflections will occur, the dependence of the field strength on the distance will not correlate so closely.

A.3.3 Calibration of the shielded anechoic chamber

Careful calibration of the chamber shall be performed over the range 30 MHz to 12,75 GHz.

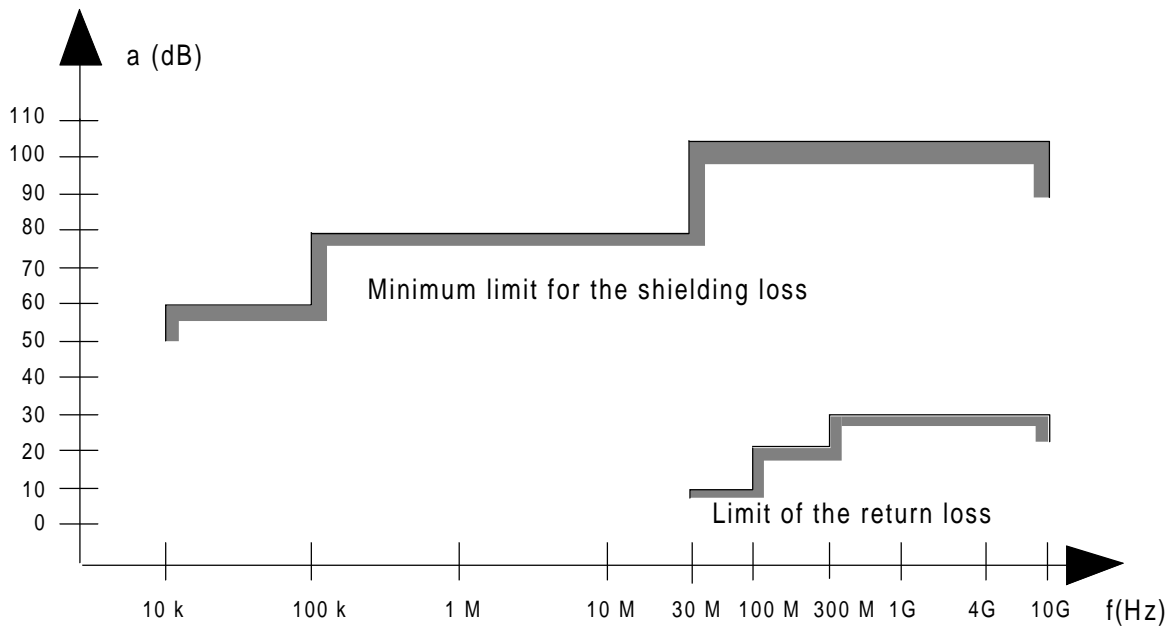

a = attenuation, f = frequency;

Figure A.3: Specifications for shielding and reflections

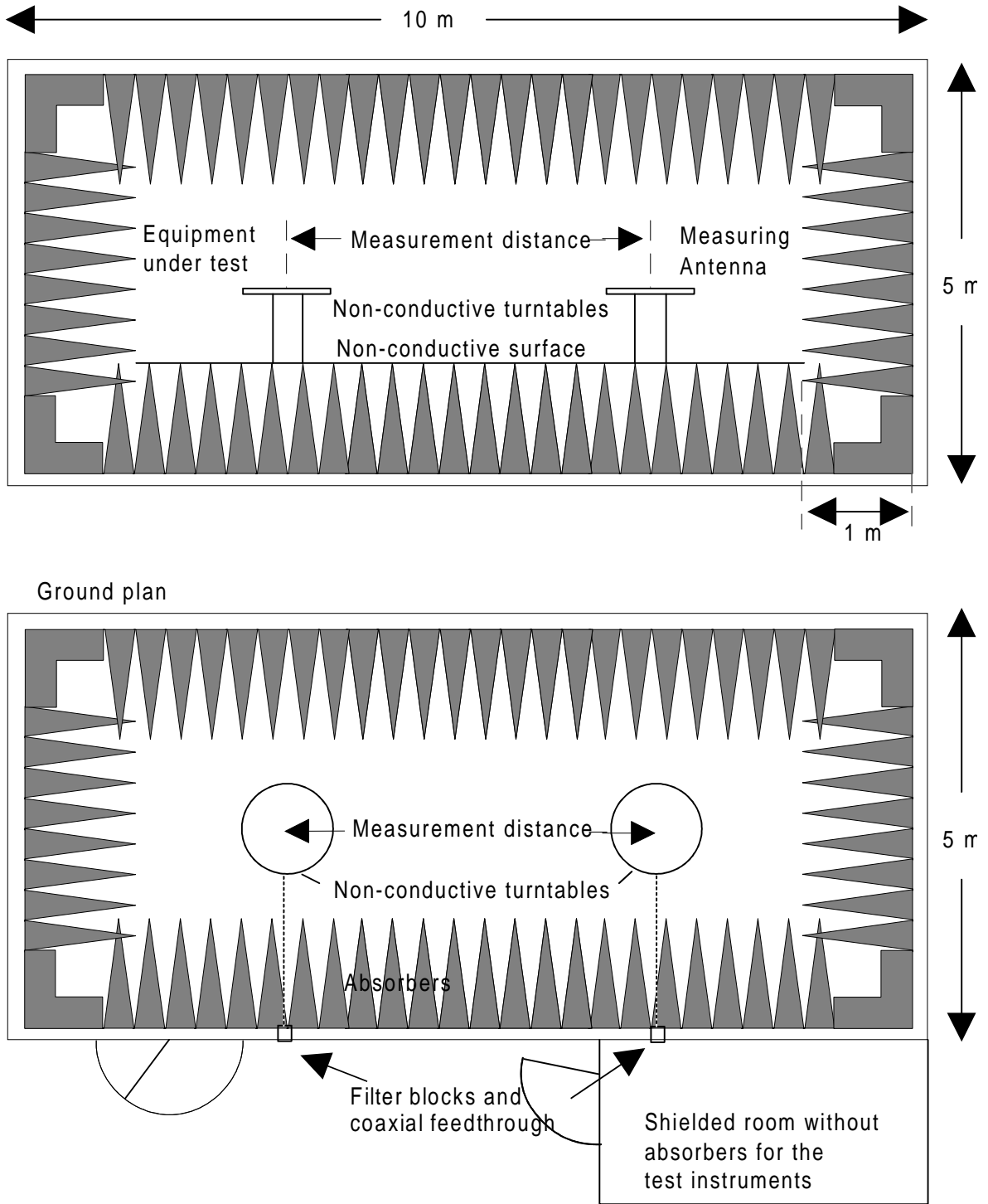

Figure A.4: Example of the construction of an anechoic shielded chamber

Annex B (normative): Specification for some particular measurement arrangements

B.1 Power measuring receiver specification

The power measuring receiver consists of a mixer, an IF filter, an oscillator, an amplifier, a variable attenuator and a root mean squared (rms) value indicator.

Instead of the variable attenuator with the rms value indicator it is also possible to use a rms voltmeter calibrated in dB. The technical characteristics of the power measuring receiver are given below.

B.1.1 IF filter

The IF filter shall be within the limits of the selectivity characteristic of figure B.1.

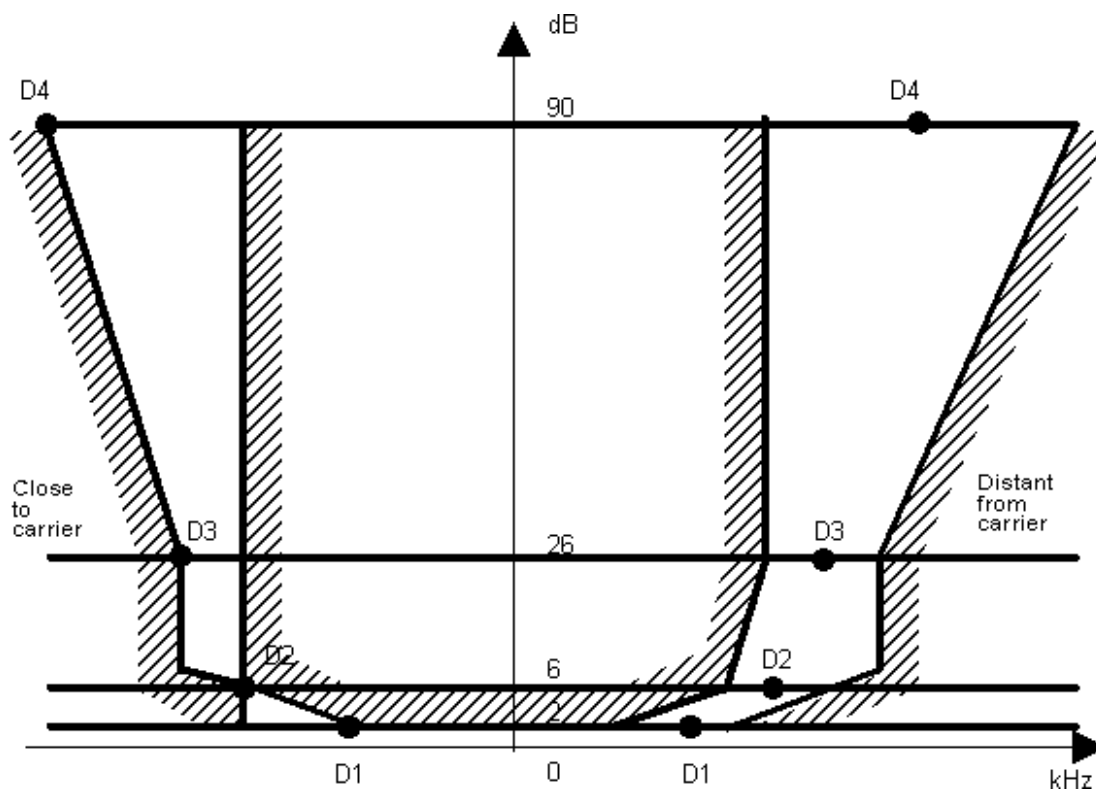

Figure B.1: IF filter

Depending on the channel separation, the selectivity characteristic shall keep the frequency separations from the nominal centre frequency of the adjacent channel as stated in table B.1.

Table B.1: Selectivity characteristic

Channel separation (kHz)	Frequency separation of filter curve from nominal centre frequency of adjacent channel (kHz)			
	D1	D2	D3	D4
12,5	3	4,25	5,5	9,5
20	4	7,0	8,25	12,25
25	5	8,0	9,25	13,25

Depending on the channel separation, the attenuation points shall not exceed the tolerances as stated in tables B.2 and B.3.

Table B.2: Attenuation points close to carrier

Channel separation (kHz)	Tolerances range (kHz)			
	D1	D2	D3	D4
12,5	+ 1,35	± 0,1	- 1,35	- 5,35
20	+ 3,1	± 0,1	- 1,35	- 5,35
25	+ 3,1	± 0,1	- 1,35	- 5,35

Table B.3: Attenuation points distant from the carrier

Channel separation (kHz)	Tolerance range (kHz)			
	D1	D2	D3	D4
12,5	± 2,0	± 2,0	± 2,0	+ 2,0 - 6,0
20	± 3,0	± 3,0	± 3,0	+ 3,0 - 7,0
25	± 3,5	± 3,5	± 3,5	+ 3,5 - 7,5

The minimum attenuation of the filter, outside the 90 dB attenuation points, shall greater than or equal to 90 dB.

B.1.2 Attenuation indicator

The attenuation indicator shall have a minimum range of 80 dB and a reading accuracy of 1 dB. With a view to future regulations, an attenuation of 90 dB or more is recommended.

B.1.3 rms value indicator

The instrument shall accurately indicate non-sinusoidal signals in a ratio of up to 10:1 between peak value and rms value.

B.1.4 Oscillator and amplifier

The oscillator and the amplifier shall be designed in such a way that the measurement of the adjacent channel power of a low-noise unmodulated transmitter, whose self-noise has a negligible influence on the measurement result, yields a measured value of ≤ -90 dB for channel separations of 20 kHz and 25 kHz and of ≤ -80 dB for a channel separation of 12,5 kHz, referred to the carrier of the oscillator.

B.2 Spectrum analyzer specification

The specification shall include the following requirements:

It shall be possible, using a resolution bandwidth of 1 kHz, to measure the amplitude of a signal, or noise at a level 3 dB or more above the noise level of the spectrum analyzer, as displayed on the screen, to an accuracy of ± 2 dB in the presence of the wanted signal.

The accuracy of relative amplitude measurements shall be within ± 1 dB.

For statistically distributed modulations, the spectrum analyzer and the integrating device (when appropriate) shall allow determination of the real spectral power density (energy per time and bandwidth), which has to be integrated over the bandwidth in question.

NOTE: This point should be considered very carefully.

B.3 Integrating and power summing device

The integrating and power summing device is connected to the video output of the spectrum analyzer, referred to in clause B.2.

It shall be possible to sum the effective power of all discrete components, the spectral power density and the noise power in the selected bandwidth and to measure this as a ratio relative to the carrier power.

The position and the width of the integration range selected can be indicated on the spectrum analyzer by brightening the trace.

Annex C (normative): Identification

The requirements set out in this annex are optional. This annex presents the technical characteristics to be fulfilled, when required by the appropriate national regulatory authority, for the identification of stations type approved for private mobile radio systems, that do not comply with other system protocols (e.g. trunking protocols); it is the responsibility of the manufacturer to ensure that the modulation that he has chosen for the identification, in accordance with the tables of this annex fulfils the requirements corresponding to the channels where the equipment is designed to operate, as specified in the main body of this ETS. The tables of this annex are expected to be updated regularly in order to reflect the progress accomplished in the field of mobile data transmissions.

C.1 Scope

The identification code should fulfil the specifications given in this annex unless identification is included in a system protocol approved by the appropriate Administration. It should also be used by combined speech/non speech equipment in the case of speech transmissions.

C.2 General

The design of a mobile system depends upon the requirements of that system, the evolution of technology and the specific needs and/or requirements of each country or region. When possible, the transmission of the identification code (ID) would use the same techniques as the transmission of the user information itself. Therefore, a variety of possibilities have been specified in this annex. They are presented using several item tables and/or cross-tables:

- modulation (indicating speed, channel separation and modulation): see table C.1;
- bitsync (if needed) and synchronisation word: see table C.2;
- redundancy code (Forward Error Correction (FEC)) and length of the useful bits protected by that code (e.g. Cyclic Redundancy Code (CRC)): see table C.3;
- header of the ID (length and contents should be unique to avoid ambiguous situations): see table C.4;
- country or regional code and length of national or regional information: see table C.5;
- national/regional information subdivided in fields: table C.6 (table C.7 and figures C.2 to C.6);
- combinations of the previous items that could be used: see table C.8;
- combinations of the previous items that will in fact be used in the various countries or regions: see table C.9;
- organisation of the fields that will in fact be used in the various countries or regions: see table C.10.

These tables can be used by manufacturers for the design of the equipment, for the type testing of the equipment and by the monitoring stations for the analysis of the identification of the transmissions.

It is the responsibility of the manufacturer to ensure that the modulation that he has chosen for the identification, in accordance with the tables of this annex, fulfils the requirements corresponding to the channels where the equipment is designed to operate, as specified in the main body of this ETS.

C.3 Position of the identification code

Considering that a receiver in the monitoring service is often operated in scanning mode and stops on a detected carrier, the identification code will be transmitted as described below.

C.3.1 Base stations

For base stations, the identification, ID, should be transmitted at the beginning and end of each session, at the end of the corresponding packets. If the session lasts for more than 3 minutes, an ID will also be

transmitted at the end of the first transmitted packet after the moment when 3 minutes have elapsed since the last transmission of the ID (this is the "3 minutes rule"). There is no need for more than one ID per packet, unless 3 minutes have elapsed since the last transmission of the ID.

C.3.1.1 System without windows

In the case of continuous transmissions, the "3 minutes rule" should apply (not more than 3 minutes between transmissions of the ID).

C.3.1.2 Systems with windows

In the case of windows of less than 3 minutes, the ID should also be sent at the end of the first packet of each window.

In the case of windows of more than 3 minutes, the ID should, in addition, be sent according to the "3 minutes rule".

C.3.2 Mobile stations

The same rule as for the base stations applies except that a mobile only transmitting to a Base Station (BS) with a transmission shorter than 300 ms (e.g. the duration of a data burst), does not have to transmit its ID systematically in each session. Instead, the 3 minute rule applies, as follows:

- the ID should be sent at the end of the first packet to be sent after the moment when 3 minutes have elapsed since the last transmission of the ID.

C.4 Bit rates and modulations

Using table C.1, demodulation can be performed, producing a bit stream.

In the case of sub-carrier modulation (indirect modulation), the carrier can be modulated in phase (/ph.) or frequency (/frq.).

Table C.1: Bit rate and modulation schemes

Name	Bit Rate (b/s)	Channel separation (kHz)	Modulation (or reference)	Details (or reference)
MM12n /ph. /frq.	1 200	12,5	MSK (FFSK)	0 = 1 800 Hz, 1 = 1 200 Hz
MM12w /ph. /frq.	1 200	20 / 25	MSK (FFSK)	0 = 1 800 Hz, 1 = 1 200 Hz
MV22w	1 200	20 / 25	CCITT V 22	4 phase state
MV23w	1 200	20 / 25	CCITT V 23	0 = 2 100 Hz, 1 = 1 300 Hz
MM24n	2 400	12,5	MSK (FFSK)	0 = 2 400 Hz, 1 = 1 200 Hz
MM24w	2 400	20 / 25	MSK (FFSK)	0 = 2 400 Hz, 1 = 1 200 Hz
MD24n	2 400	12,5	Direct	
MD24w	2 400	20 / 25	Direct	
MM36n	3 600	12,5	MSK (FFSK)	0 = 3 600 Hz, 1 = 1 800 Hz
MM36w	3 600	20 / 25	MSK (FFSK)	0 = 3 600 Hz, 1 = 1 800 Hz
MD36n	3 600	12,5	Direct	
MD36w	3 600	20 / 25	Direct	
		(continued)		

Table C.1 (concluded): Bit rate and modulation schemes

Name	Bit Rate (b/s)	Channel separation (kHz)	Modulation (or reference)	Details (or reference)
MM48n	4 800	12,5	MSK (FFSK)	0 = 4 800 Hz, 1 = 2 400 Hz
MM48w	4 800	20 / 25	MSK (FFSK)	0 = 4 800 Hz, 1 = 2 400 Hz
MD48n	4 800	12,5	Direct	
MD48w	4 800	20 / 25	Direct	
MD72n	7 200	12,5	Direct	
MD72w	7 200	20 / 25	Direct	
MD80n	8 000	12,5	Direct	
MD80w	8 000	20 / 25	Direct	
MD96n	9 600	12,5	Direct	
MD96w	9 600	20 / 25	Direct	
MD160	16 000	(20) / 25	Direct	
MD192	19 200	25	Direct	
NOTE 1:	The direct modulation concerns only constant envelope modulation methods and includes: GMSK, generalised tamed FM, multilevel state FM, PLL-4-PSK, 8 PSK.			
NOTE 2:	Other modulation systems are under consideration and may be added later to this table if proven to provide better performance.			
NOTE 3:	The frequency shift used with the direct FSK modulation should be chosen to meet subclause 8.5 (adjacent channel transmitter power).			
NOTE 4:	Some modulation methods presented in this table have not yet been proven to meet subclause 8.5 (adjacent channel transmitter power).			

C.5 Format of the identification

The identification, ID, should be transmitted in one block (see definitions in subclause 3.1).

If bit rate/modulation used to transmit "user's information" and of the "ID block" are not the same, the "ID block" should be preceded by "bit sync".

If bit rate and modulation are the same, the "bit sync" is optional. However, it is well known that the autocorrelation properties of the "sync words" are calculated with respect to their corresponding "bit sync" (see table C.2).

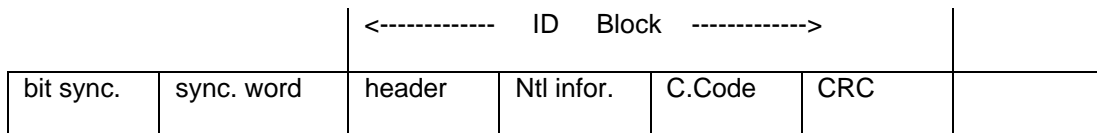

Figure C.1: ID block organisation

C.6 Synchronisation

Using table C.2, the monitoring station receiver/decoder can be synchronised (detection of the beginning of each block) and bits can be extracted from the bit stream. Bits should be transmitted in the order of Most Significant Bit (MSB) first.

Table C.2: Synchronisation

bit sync (if needed)	Sync. word		Notes
	name	value	
1010 1010 1010 1010	S1	1011 0100 0011 0011	Note 1
1010 1010 1010 1010	S2	0011 1011 0010 1000	
10 10 10 10	S3	1100 1110 00	Note 2
01 01 01 01	S3'	0011 0001 11	Note 2
1010 1010 1010 1010	S4	1100 0100 1101 0111	
1010 1010 1010 1010	S5	(1)010 0010 1111 0111	
	S6	(1)101 1101 0000 1000	
1010 1010 1010 1010	S7	1010 1111 0001 0010	
NOTE 1: This sync word has optimal autocorrelation properties.			
NOTE 2: Frame synchronisation comprises 10 bits with the structure: S3 = transmissions Base to Handportable/Mobile; S3' = transmissions Handportable/Mobile to Base. Only these 10 bits are used for frame synchronisation when handportables or mobiles evaluate base stations. These 10 bits plus base identity (10 bits) in the scheme apply to all other communication with the current base as synchronisation word for frame synchronisation. Furthermore, four control flags are included in the synchronisation word, i.e. the total length of the frame head is: 24 bits + bit sync.			

NOTE: Table C.2 is valid in the case of modulations for which 101010 is an effective bit sync pattern. In the case of direct modulation methods for which the patterns given in table C.2 are not appropriate, the way in which entries of table C.2 have to be adapted to the constraints of a particular type of modulation, is to be agreed by the appropriate Administration.

C.7 Code and block length

Using table C.3, the "useful" bits of each block can be counted and checked (error detection can be performed). Corrections could also be performed: a trade-off between detection and correction performance and notes concerning the code are proposed in column "Det/Corr" (information concerning detection/correction).

Table C.3: Code and block length

Name	Sizes	Notes	Details	Det/Corr
C1	(64,48)		$X^{15}+X^{14}+X^{13}+X^{11}+X^4+X^2+1$ cyclic (63,48), LSB inv. +1 parity (even) bit appended	Det =< 5 errors
C2	(n+8,n)		$X^8+X^7+X^4+1$ all bits	
C3	(69,48)		Shortened cyclic	Det/Corr
C4	(16,8)	Note 1	Block code: Corr 2 er.	
OC1	16*(8,4)	Note 2	for "overcoding" the block in certain frequency bands parity check matrix: (01 -- -- --) (10 01 -- --) (10 10 01 --) (00 10 10 01)	Corr 2 err.
NOTE 1: Code C4 may be used in systems which need high protection and with a small amount of data to be transferred in a normal transmission. (6 blocks are needed to transmit the ID).				
NOTE 2: Code OC1, in some frequency bands, may be used to protect all the bits of the block (in order to allow the correction of errors due to ignition noise, etc.). In the case where the code OC1 is used, the code C1 should only be used for error detection.				

C.8 Contents of the identification block

C.8.1 Header

Using table C.4, the nature of the information contained in one particular block can be determined as ID or users/system information.

Many of the combinations in this header are free for other use. Using such an organisation could allow systems using only one block for the ID to use the first bit of the blocks as an "ID/information flag" (user/system), while leaving it open for others to use more bits.

For hunting purposes, the bits of the header could also be considered as part of the sync word.

Table C.4: Header information

Name	Length	Binary	Interpretation
H1	4 bits	Hn2 = 0 0 x x	ID word to be used during the session (monitored on F1 or F2)
		Hn1 = 0 1 x x	ID word transmitting on F1; it can be used to activate the corresponding repeater
		Hd = 1 y x x	user/system information block; bits y and x are free for future use or for transmitting user/system information
NOTE:		When a repeater is used, "F1" is the frequency used for the mobiles to transmit, "F2" is the output frequency of the repeater.	

C.8.2 Country/regional code

Table C.5 allows for the transcoding of the 5 bit CC field into the country or region to which the ID has been allocated.

The codes found in this table have originally been allocated so that the codes corresponding to regions close to each other are separated by a large Hamming distance (i.e. many bits are different). This table has been subsequently expanded in such a way to ensure "upwards compatibility".

Table C.5: Country codes

Country code	Country	Length of Ntl info (if deviating from 39 bits) (subclause C.8.3)
00 000	Others	
01 111	Germany (Fed. Rep.)	41 bits
01 110	Andorra	(Note 2)
11 001	Austria	
10 110	Baltic Republics	(Note 2)
00 110	Bulgaria	(Note 2)
01 100	Belgium	
11 101	Croatia	(Note 2)
00 100	Cyprus	
00 011	Czech Republic	(Note 2)
01 000	Denmark	
10 111	Spain	
01 110	Faroe Islands	(Note 2)
01 011	Finland	
10 000	France	
10 011	Russia and countries from IEC not explicitly quoted in the table	
00 111	Greece	
00 110	Hungary	(Note 2)
11 110	Ireland	
11 000	Iceland	
01 010	Italy	
11 010	Liechtenstein	
11 011	Luxembourg	
11 101	Malta	(Note 2)
11 111	Monaco	
01 101	Norway	
10 001	Netherlands	
10 101	Poland	
00 010	Portugal	
00 110	Romania	(Note 2)
01 001	United Kingdom	
10 110	San Marino	(Note 2)
00 011	Slovak Republic	(Note 2)
11 101	Slovenia	(Note 2)
10 010	Sweden	
00 101	Switzerland	
11 100	Turkey	
00 001	Vatican (City)	
10 100	Countries from ex-Yugoslavia not explicitly quoted in the table.	
NOTE 1:	In the allocation some codes are missing due to recent developments in Europe; this table will be completed when possible in the future.	
NOTE 2:	Two or more countries can use the same 5 bit CC code in which case the differentiation can be made using the LOF field ("Regional Licensing Office).	
NOTE 3:	When mobiles from two or more countries are not expected to interfere with each other, then these countries can use the same 5 bit CC code.	

C.8.3 National Information

The following options for the fields containing the "National" (Ntl) information are based on the assumption that the ID blocks contain 48 useful bits and provide 39 bits for the "National" information field ("Ntl info" or field F).

C.8.3.1 Field description

The fields shown in table C.6 can either be used for the purpose of identification and/or used for transmitting information corresponding to user data or system needs.

Table C.6: Field description

Category	No of bits
Licensee number	Lnb: 0 - 14
Individual transmitter identification	TID: 0 - 20
Network identification	NID:14 - 20
Regional licensing office	LOF: 0 - 8
Relay station number	Rnb: 0 - 12
National Additional information	NAI: 0 - 20
User group	UG : 0 - 7
Field free for system or user data	FF :

The maximum total number of bits available in field F is 39 bits (however national information can go up to 41 bits by overflow of 2 bits into the header Hxx bits).

All categories are expected to be coded in binary (and will be presented in 4 bit nibbles).

C.8.3.2 Field size options

Table C.7: Field size options

Name of the scheme	Field description		
	Size	Name	Usage
FZ1	7 bits	LOF	regional licensing office ID
	7 bits	UG	user group
	14 bits	NID	network identification
	13 bits	TID	individual transmitter ID
FZ2	5 bits	Rnb	relay number
	18 bits	NID	network ID
	12 bits	TID	individual mobile number
FZ3	27 bits	Lnb	licensee number
	14 bits	NID	network ID

C.8.3.3 Options for the organisation of the fields

Figures C.2 to C.6 show possible organisations of the fields within the "ID block".

* bit	0	2	9	13	16	30	43
sync word	H Oy	UG 7 bits	LOFM 4 bits	LOFL 3 bits	NID 14 bits	TID 13 bits	CC 5 bits

Figure C.2: FO1

bit	0	4	9	13	31	43
sync word	H Oyxx	Rnb 5 bits	FF 4 bits	NID 18 bits	TID 12 bits	CC 5 bits

Figure C.3: FO2

bit	0	2	29	43
sync word	H Oy	Lnb 27 bits	NID 14 bits	CC 5 bits

Figure C.4: FO3

bit	0	4	9	36	43
sync word	H Obxx	FF 5 bits	Lnb 27 bits	NID 7 bits	CC 5 bits

Figure C.5: FO3b

bit	0	4	9	13	17	31	43
sync word	H Obxx	Rnb 5 bits	FF 4 bits	Ext 4 bits	NID 14 bits	TID 12 bits	CC 5 bits

Figure C.6: FO4

Option F04, given in figure C.6 above, is a common representation where the field extension ("Ext" : 4 bits) could be either FF or LOF(L) or an extension for NID.

C.8.3.4 Examples of user/system information usage

The bits of the ID block that have not been allocated in table C.6 (free fields "FF") can be:

- used for numbering the blocks in the packets (e.g. 3 bits);
- used as a function code (e.g. 2 bits);
- used for the transmission of status;
- used to transmit an acknowledge;
- used to transmit a no-acknowledge;
- used to clear down the repeater (deactivation of the repeater after an activation using, for instance, Header code Hn1).

C.9 Combinations

Tables C.8 and C.9 indicate which of the combinations given in the "Items Tables" will in fact be used.

C.9.1 List of possible combinations

Table C.8 indicates the "lower layer" combinations that have been explicitly supported by the regulatory authorities and that could be accepted in some countries. Knowing these formats and codes, "Ntl information" can be easily accessed.

Table C.8: Combinations table

modulation	sync. word	code length	Header	Freq.Band	comb. name + notes
MM12w	S1	C1	H1(w/2bit)		ACx
MM12n	S1	C1	H1	< 500 MHz	ACy
MM12n,w	S3 + S3'	C3	H1	< 1000 MHz	ACzn, ACzw
MM12n,w	S7	C4	H1	< 500 MHz	ACtn, ACtw
NOTE: To be completed in the future.					

C.9.2 Relations between country/regional code and allowed combinations

Table C.9 indicates, among the combinations included in table C.8, those which are, or will soon be, effectively allowed in the different countries or regions.

Table C.9: Combinations in a country

Country code	Allowed combinations	Notes
D 01 111	ACx, Fs	Not all combinations will be allowed
And 01 110		
A 11 001		
B 01 100		
CY 00 100		
DK 01 000	Fs	
E 10 111	Fs	
SF 01 011	Fs	
F 10 000	ACy	Until further notice, only one is allowed
GR 00 111		
IRL 11 110		
IS 11 000		
I 01 010	Fs	
FL 11 010		
L 11 011		
M 11 101		
MC 11 111		
N 01 101	Fs	
NL 10 001	Fs	In the future only a few combinations will be allowed
P 00 010	Fs	
GB 01 001	ACy	Other combinations may be allowed
SMR 10 110		
S 10 010	ACzw, ACtw	Other combinations may be allowed
CH 00 101	Fs	
TR 11 100		
SCV 00 001		
YU 10 100		
NOTE: Fs: further study is needed.		

C.9.3 Interpretation of the fields of the ID block

Using table C.10, interpretation of the various fields could be performed.

Table C.10: Interpretation table

Country code		Scheme for organisation of NTL info (note 2)
D	01 111	Z1 / F01
And	01 110	
A	11 001	
B	01 100	
CY	00 100	
DK	01 000	Fs (note 1)
E	10 111	Fs
SF	01 011	Fs
F	10 000	FZ2 / F02, equivalent to F04 with EXT used for extension of NID
GR	00 111	
IRL	11 110	
IS	11 000	
I	01 010	Fs
FL	11 010	
L	11 011	
M	11 101	
MC	11 111	
N	01 101	
NL	10 001	
P	00 010	
GB	01 001	
SMR	10 110	
S	10 010	Fs
CH	00 101	
TR	11 100	
SCV	00 001	
YU	10 100	
NOTE 1:	Fs: further study is needed.	
NOTE 2:	For NTL information see subclause C.8.3, including tables C.6 and C.7 and figures C.2 to C.6.	

Annex D (informative): Graphic representation of the selection of equipment and frequencies for testing

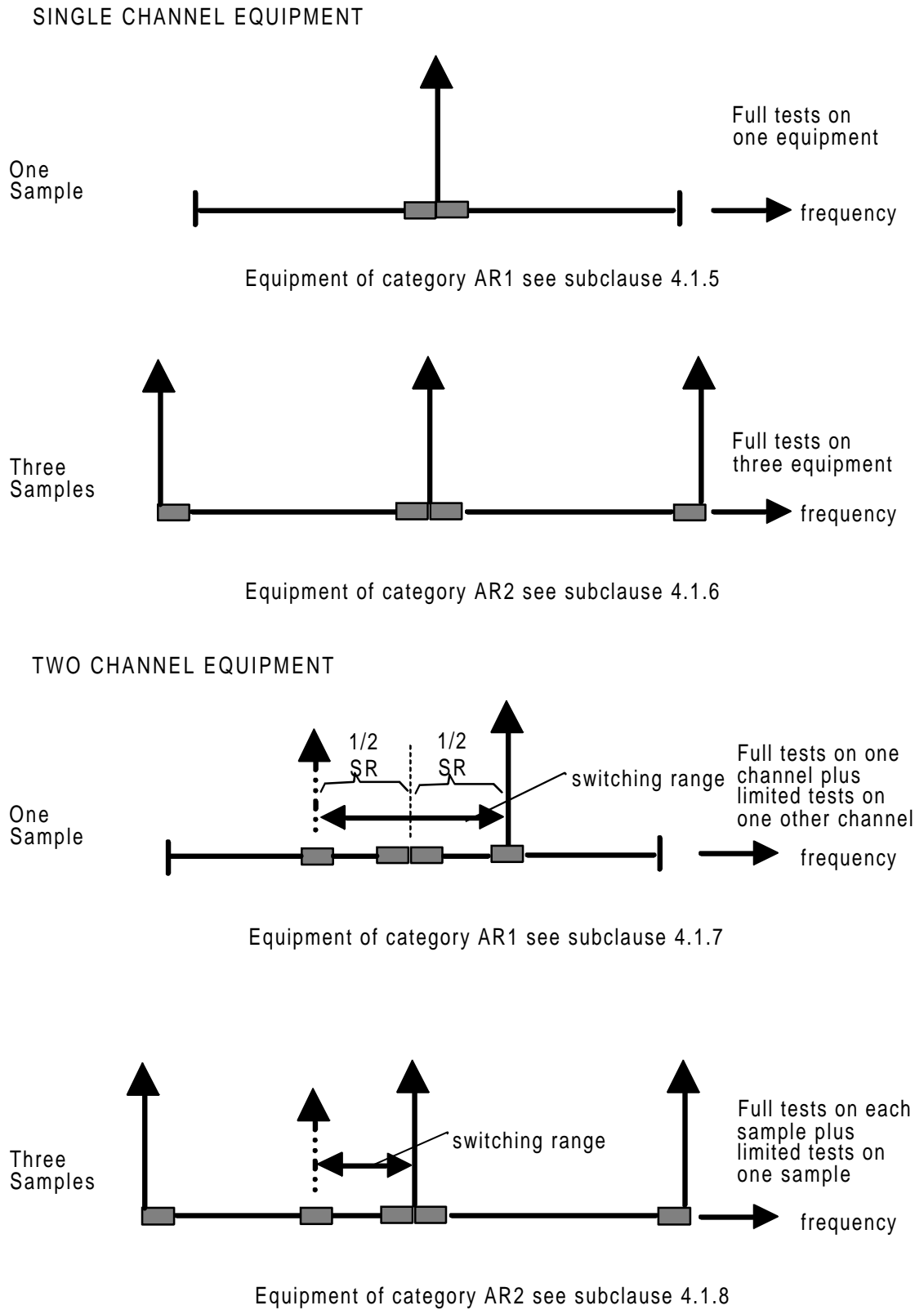

NOTE: For legend see figure D.2.

Figure D.1: Single channel/two channel equipment

MULTI CHANNEL EQUIPMENT

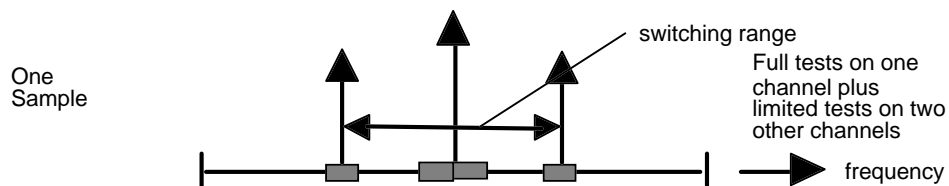

Equipment of category AR1 see subclause 4.1.9

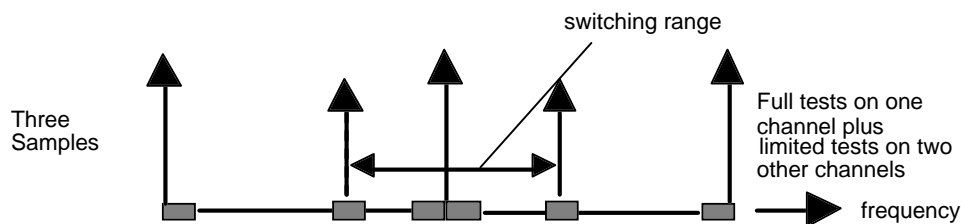

Equipment of category AR2 see subclause 4.1.10

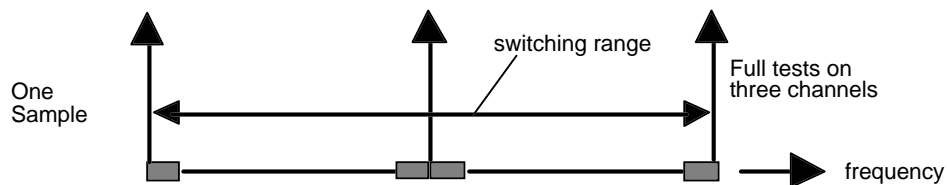

Equipment of category AR2 see subclause 4.1.11
 AR = SR

Legend:

AR1 - First category of alignment range, see subclause 4.1.3.

AR2 - Second category of alignment range, see subclause 4.1.3.

Limited test, see subclause 3.1.

Full test, see subclause 3.1.

100 kHz range in which the test shall be carried out.

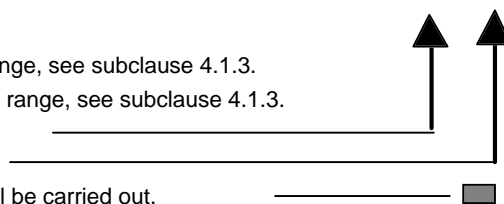

Figure D.2: Multichannel equipment

Annex E (informative): Information on modulation, coding and format

It is pointed out that this ETS addresses only the minimum performance of the hardware/lower layers of the data equipment and that it does not cover measurements that confirm the bit error ratio performance of the radio data systems in real or simulated mobile environment conditions (multipath fading, burst interference, ignition noise, etc.).

Attention is drawn to the fact that CCITT (ITU/T) Recommendations do not address the mobile system bit error ratio issue. Therefore equipment designed to meet such standards is not necessarily suitable for use in mobile radio systems. Specifically external modems, protocols and also ancillary units used in conjunction with mobile radio equipment should be capable of operating with the mobile radio system in such a manner as to minimise the system bit error ratio in real conditions, and to provide good spectrum efficiency.

Attention is also drawn to the availability of CCIR (ITU/R) Recommendations and reports on the subject (see CCIR volume VIII).

Furthermore, it is recommended to obtain the approval of the mobile radio manufacturer of any equipment to be incorporated in a mobile radio data system (e.g. in "OEM" basis).

Annex F (informative): Bibliography

- COST 207 final report, Brussels 1989.

History

Document history			
January 1995	Public Enquiry	PE 78:	1995-01-30 to 1995-05-26
March 1996	Vote	V 99:	1996-03-04 to 1996-04-26