



**E**UROPEAN  
**T**ELECOMMUNICATION  
**S**TANDARD

**DRAFT**  
pr **ETS 300 099**

September 1996

Second Edition

---

Source: ETSI TC-NA

Reference: RE/NA-023206

ICS: 33.080

**Key words:** ISDN, access, interface

## **Integrated Services Digital Network (ISDN); Specification of the Packet Handler access point Interface (PHI)**

**ETSI**

European Telecommunications Standards Institute

**ETSI Secretariat**

**Postal address:** F-06921 Sophia Antipolis CEDEX - FRANCE

**Office address:** 650 Route des Lucioles - Sophia Antipolis - Valbonne - FRANCE

**X.400:** c=fr, a=atlas, p=etsi, s=secretariat - **Internet:** secretariat@etsi.fr

Tel.: +33 92 94 42 00 - Fax: +33 93 65 47 16

---

**Copyright Notification:** No part may be reproduced except as authorized by written permission. The copyright and the foregoing restriction extend to reproduction in all media.

© European Telecommunications Standards Institute 1996. All rights reserved.



## Contents

Foreword .....	11
Overview of the main changes from edition 1 of this ETS .....	12
1 Scope .....	13
2 Normative references .....	14
3 Definitions and abbreviations .....	16
3.1 Definitions .....	16
3.2 Abbreviations .....	17
4 Reference configuration and functional model.....	18
4.1 Reference configuration.....	18
4.2 Basic functional model.....	19
4.3 Functional model for remote access to the PHI.....	20
5 Services supported by the PHI specification .....	21
5.1 Basic service aspects .....	21
5.1.1 Services provided on the B-channel.....	22
5.1.1.1 Semi-permanent B-channel access .....	22
5.1.1.2 Switched B-channel access.....	22
5.1.1.3 Switched long-duration B-channel access (case B) .....	22
5.1.2 Services provided on the D-channel (case B).....	23
5.1.2.1 Semi-permanent D-channel access .....	23
5.1.2.2 PLL access .....	23
5.1.2.3 Long duration PLL access .....	24
5.1.2.4 Switched D-channel access .....	24
5.1.3 Subscription and related data.....	24
5.2 Detailed service aspects .....	25
5.2.1 Notification of incoming calls .....	25
5.2.1.1 No Notification Class .....	25
5.2.1.2 Conditional Notification Class .....	25
5.2.2 Mapping of information elements .....	26
5.2.3 Access connection release.....	26
5.2.4 Access collision .....	26
5.2.5 Cause mappings .....	26
5.3 Numbering, addressing and terminal selection.....	27
5.3.1 Numbering and addressing .....	27
5.3.2 Terminal selection and compatibility checking .....	28
5.3.3 Directory number and services association.....	28
5.4 Services cross-reference and conformance statement for the PHI.....	28
6 Basic interface structure.....	30
6.1 General .....	30
6.2 Interface architecture for single-PRA PHI.....	30
6.2.1 Local PHI access.....	30
6.2.2 Remote PHI access .....	30
6.3 PHI channel types .....	32
6.3.1 D64-channel .....	32
6.3.2 Bb-channels (case A and case B) .....	33
6.3.3 Bd-channels .....	34
6.3.3.1 Data transfer .....	34
6.3.3.2 Link layer management .....	35
7 Interface configuration.....	36

7.1	Frame handler function at the CRF-S .....	36
7.2	Multi-PRA PHI configuration.....	36
8	Operations, Administration and Maintenance (OA&M).....	36
8.1	General.....	36
8.1.1	Scope.....	36
8.1.2	Definitions.....	37
8.1.3	Principles.....	37
8.2	Layer 1 OA&M requirements.....	37
8.2.1	Administration.....	37
8.2.1.1	Provisioning of semi-permanent Bb-channels .....	37
8.2.1.2	Provisioning of semi-permanent Bd-channels .....	38
8.2.2	Operations and maintenance.....	38
8.2.2.1	Primary rate access .....	38
8.2.2.2	Establishment and release of switched Bd-channels due to operational requirements .....	38
8.2.2.3	Re-establishment of dynamically provisioned semi-permanent Bd-channels in case of failure.....	38
8.3	Layer 2 OA&M requirements.....	38
8.3.1	Bb-channels.....	38
8.3.2	Bd-channels.....	38
8.3.2.1	Administration .....	38
8.3.2.2	Operations.....	39
8.3.2.2.1	General status and performance monitoring .....	39
8.3.2.2.2	Load sharing.....	39
8.3.2.3	Maintenance.....	39
8.3.3	D64-channel .....	39
8.4	Layer 3 OA&M requirements.....	40
8.4.1	Service support.....	40
8.4.1.1	ITU-T Recommendation X.25 Packet Layer Procedures (X.25PLP).....	40
8.4.1.2	PVCs on the D-channel.....	40
8.4.2	Signalling (D64 and Bd-inband).....	40
8.4.2.1	Administration .....	40
8.4.2.2	Operations.....	40
8.4.2.2.1	D64-signalling.....	40
8.4.2.2.2	Bd-inband signalling.....	40
8.4.2.3	Maintenance.....	41
8.4.2.3.1	D64-signalling.....	41
8.4.2.3.2	Bd-inband signalling.....	41
9	Frame multiplexing on the Bd-channels .....	41
9.1	Principle.....	41
9.2	Address field layout .....	42
9.3	Subscriber data links.....	43
9.4	Signalling data link .....	43
9.4.1	The DLCI value of the signalling data link .....	43
9.4.2	Establishment of the signalling data link.....	43
9.4.3	Signalling data link failure .....	43
9.4.4	Recovery of the signalling data link .....	43
9.5	Switchover and concentration .....	44
9.6	Reset procedures.....	44
9.7	Bd-channel continuity check.....	44
9.7.1	HDLC flag continuity check procedure .....	45
9.7.2	Management frame continuity check procedure.....	45
9.7.2.1	Both-way procedure description.....	45
9.7.2.2	One-way procedure description .....	46
9.7.2.3	Management frame layouts .....	46
9.7.2.4	Parameter set .....	47
9.8	Connection verification procedure.....	47
9.9	Peer busy procedures .....	47
9.10	Default timer values .....	48

9.11	Maintenance flow .....	48
10	PHI signalling .....	48
10.1	General introduction.....	48
10.1.1	Signalling procedures.....	48
10.1.2	Signalling messages .....	48
10.1.3	Information Elements .....	48
10.2	B-channel services, switched, case A .....	49
10.2.1	Signalling messages .....	49
10.2.1.1	Call proceeding.....	50
10.2.1.2	Connect .....	50
10.2.1.3	Connect acknowledge .....	50
10.2.1.4	Disconnect.....	50
10.2.1.5	Release.....	51
10.2.1.6	Release complete .....	51
10.2.1.7	Setup .....	51
10.2.1.8	Status.....	52
10.2.1.9	Status enquiry.....	52
10.2.2	Case A, procedures for an outgoing call (CRF-P to PH).....	52
10.2.3	Case A, procedures for an incoming call (PH to CRF-P).....	53
10.2.4	Case A, procedures for call clearing .....	54
10.3	B-channel services, switched, case B .....	54
10.3.1	Signalling messages .....	54
10.3.1.1	Call proceeding.....	55
10.3.1.2	Connect .....	55
10.3.1.3	Connect acknowledge .....	55
10.3.1.4	Disconnect.....	55
10.3.1.5	Release.....	56
10.3.1.6	Release complete .....	56
10.3.1.7	Setup .....	56
10.3.1.8	Status.....	57
10.3.1.9	Status enquiry.....	57
10.3.2	Case B, procedures for an outgoing call (CRF-P to PH).....	57
10.3.3	Case B, procedures for an incoming call (PH to CRF-P).....	58
10.3.4	Case B, procedures for call clearing .....	59
10.4	Dynamically provisioned semi-permanent and switched Bd-channels .....	59
10.4.1	Signalling messages for circuit mode procedures.....	60
10.4.1.1	Connect .....	60
10.4.1.2	Setup .....	60
10.4.2	Signalling messages for packet mode procedures .....	60
10.4.2.1	Connect .....	60
10.4.2.2	Setup .....	61
10.4.3	Procedures for Bd-channels established by the CRF-S (CRF-P to PH) .....	61
10.4.4	Procedures for Bd-channels established by the PH (PH to CRF-P) .....	62
10.4.5	Procedures for Bd-channel access connection clearing .....	63
10.5	D-channel services, switched, case B .....	63
10.5.1	Signalling messages .....	64
10.5.1.1	Connect .....	64
10.5.1.2	Release.....	64
10.5.1.3	Release complete .....	65
10.5.1.4	Setup .....	65
10.5.1.5	Status.....	66
10.5.2	Procedures for data link establishment by the CRF-S (CRF-S to PH).....	66
10.5.3	Procedures for data link establishment by the PH (PH to CRF-S).....	68
10.5.4	Procedures for data link disconnection .....	70
10.5.5	Procedures after receipt of a STATUS message.....	70
10.6	Restart on the D64-channel.....	70
10.6.1	Signalling messages .....	70
10.6.1.1	Restart .....	71
10.6.1.2	Restart acknowledge .....	71
10.6.1.3	Status.....	71
10.6.2	Restart procedure.....	71
10.7	The timers T320, TPHI, TPH, and TCRF .....	72

11	Static and dynamic provisioning for PLL and semi-permanent services .....	72
11.1	General Introduction.....	72
11.1.1	Signalling procedures .....	72
11.1.2	Signalling messages.....	73
11.1.3	Information elements .....	73
11.2	B-channel services, case A and case B, semi-permanent.....	73
11.2.1	Static provisioning.....	73
11.2.2	Dynamic provisioning.....	73
11.3	Semi-permanent Bd-channels.....	73
11.3.1	Static provisioning.....	73
11.3.2	Dynamic provisioning.....	73
11.3.3	Deregistration of dynamically provisioned Bd-channels .....	73
11.4	D-channel services, PLL .....	74
11.4.1	PLL data link provisioning, static .....	74
11.4.2	Messages for dynamic provisioning of PLL data links.....	74
11.4.2.1	Register .....	74
11.4.2.2	Release complete .....	74
11.4.2.3	The linked identifier of the invoke component .....	75
11.4.2.4	The argument of the invoke component .....	75
11.4.2.5	The result of the return result component.....	75
11.4.2.6	The error value of the return error component.....	75
11.4.2.7	The parameter of the return error component .....	76
11.4.3	Procedures for PLL data link registration by the CRF-S (CRF-S to PH) .....	76
11.4.4	Procedures for PLL data link registration by the PH (PH to CRF-S) .....	77
11.4.5	Procedures for PLL data link deregistration .....	78
11.5	D-channel services, semi-permanent .....	78
11.5.1	Semi-permanent data link provisioning, static.....	78
11.5.2	Messages for dynamic provisioning of semi-permanent data links .....	78
11.5.3	Procedures for semi-permanent data link registration.....	79
11.5.4	Procedures for semi-permanent data link deregistration.....	79
12	Exception handling .....	79
12.1	B-channel service (case A and B).....	79
12.1.1	Outgoing call.....	79
12.1.2	Incoming call.....	79
12.1.2.1	Unsuccessful call .....	79
12.1.2.2	Premature clearing by remote terminal.....	79
12.1.2.3	No Bb-channel available .....	80
12.1.2.4	Data link disconnect.....	80
12.1.2.5	Acceptance of call on existing B-channel .....	80
12.1.3	Call collision.....	80
12.1.4	Data transfer phase .....	80
12.1.4.1	Subscriber disconnects data link .....	80
12.1.4.2	Bb-channel is cleared.....	80
12.1.4.3	Restart on PHI.....	80
12.2	Bd-channel establishment.....	81
12.2.1	Bd-channel establishment by the CRF-S.....	81
12.2.1.1	Corrupted "user-user" information element.....	81
12.2.2	Bd-channel establishment by the PH.....	81
12.2.2.1	Corrupted "user-user" information element.....	81
12.3	Switched D-channel service .....	81
12.3.1	Exception resolution using layer 2 procedures .....	81
12.3.1.1	Exception reporting on the user-network interface .....	82
12.3.1.2	No exception reporting.....	82
12.3.1.3	Exception reporting on the Bd-channel.....	82
12.3.2	Outgoing call.....	82
12.3.2.1	No Bd-channel available .....	82
12.3.2.2	Signalling data link disconnection .....	82
12.3.2.3	Data link establishment rejection .....	83
12.3.2.4	Repeated DLCI .....	83
12.3.3	Incoming call.....	83
12.3.3.1	Unsuccessful call .....	83
12.3.3.2	Premature clearing by remote terminal.....	83

	12.3.3.3	No Bd-channel available .....	84
	12.3.3.4	Signalling data link disconnection .....	84
	12.3.3.5	Acceptance of call on existing data link .....	84
	12.3.3.6	Repeated DLCI .....	84
	12.3.3.7	Data link disconnect .....	84
	12.3.4	Call collision .....	85
	12.3.5	Data transfer phase .....	85
	12.3.5.1	Subscriber disconnects data link .....	85
	12.3.5.2	Bd-channel is cleared .....	85
	12.3.5.3	Restart on PHI .....	85
12.4		PLL or semi-permanent D-channel service .....	85
	12.4.1	Outgoing call .....	85
	12.4.1.1	No Bd-channel available .....	85
	12.4.1.2	SETUP with PLL (semi-permanent) DLCI value .....	85
	12.4.1.3	SABME with unknown DLCI .....	85
	12.4.2	Incoming call .....	86
	12.4.2.1	No Bd-channel available .....	86
	12.4.2.2	SABME with unknown DLCI .....	86
	12.4.3	Call collision .....	86
	12.4.3.1	Call collision on network-user interface .....	86
	12.4.3.2	Call collision on the Bd-channel .....	86
	12.4.4	Data transfer phase .....	86
12.5		PLL or semi-permanent registration or deregistration .....	87
	12.5.1	Registration and deregistration by the CRF-S .....	87
	12.5.1.1	Data link disconnection .....	87
	12.5.1.2	Repeated DLCI .....	87
	12.5.1.3	Unknown deregistration parameter .....	87
	12.5.2	Registration or deregistration by the PH .....	87
	12.5.2.1	Data link disconnection .....	87
	12.5.2.2	Repeated "called party number" .....	87
	12.5.2.3	Repeated DLCI .....	88
	12.5.2.4	Unknown deregistration parameter .....	88
13		Additional information elements for PHI signalling .....	88
	13.1	Coding rules .....	88
	13.2	Coding of the additional information elements .....	90
	13.2.1	DLCI value .....	90
	13.2.2	Bd-channel reference number .....	91
	13.2.3	FH reference number .....	91
	13.2.4	Additional subscriber information .....	92
	13.2.5	Type of service .....	92
	13.2.6	Called party number .....	93
	13.2.7	Cause .....	93
	13.3	Coding of the facility Information Element .....	93
	13.3.1	Embedded information elements .....	93
	13.3.2	Operation value .....	93
	13.3.3	Error value .....	94
	Annex A (informative):	Requirements on the common channel signalling system .....	95
	Annex B (informative):	PHI signalling diagrams .....	96
B.1		Introduction .....	96
	B.1.1	Conventions for the diagrams .....	96
B.2		B-channel services case A .....	99
	B.2.1	B-channel establishment .....	99
	B.2.2	B-channel disconnection .....	100
B.3		B-channel services case B .....	103
	B.3.1	B-channel establishment .....	103
B.4		Dynamic Bd-channels .....	108

B.4.1	Bd-channel establishment.....	108
B.5	Data link establishment and release.....	112
B.5.1	D-channel data link establishment .....	112
B.5.2	D-channel link disconnection .....	118
B.6	Bd-channel establishment, semipermanent .....	120
B.7	Dynamic provisioning for D-channel PLL service .....	122
B.7.1	PLL data link registration.....	122
B.7.2	PLL data link deregistration.....	124
B.8	Dynamic provisioning for D-channel semi-permanent service .....	126
B.8.1	Semi-permanent data link registration .....	126
B.8.2	Semi-permanent data link deregistration .....	128
Annex C (informative):	Additional information for PVCs on switched long-duration B-channel access (case B).....	129
C.1	Introduction .....	129
C.2	Procedure .....	129
C.2.1	Identification .....	129
C.2.2	B-channel establishment.....	129
C.2.3	Layer 2 and layer 3 establishment .....	129
C.2.4	Error procedures .....	129
C.2.5	Procedures for VCs on B-channels supporting PVCs.....	129
Annex D (informative):	Multi-PRA configurations .....	130
D.1	Selection by using numbers.....	130
D.2	Selection by a hunting algorithm or a call deflection mechanism .....	130
D.3	Non-associated signalling.....	130
Annex E (normative):	Switch-over and concentration procedures .....	131
E.1	Introduction .....	131
E.2	Applicability .....	131
E.3	Constraints.....	131
E.4	Procedures .....	131
E.4.1	Switchover procedures.....	131
E.4.1.1	Switchover during link establishment.....	131
E.4.1.2	Switchover of an established link.....	132
E.4.2	Detailed procedure .....	132
E.5	Traffic management considerations .....	132
E.5.1	Bd-channel failure or malfunction.....	132
E.5.2	Unexpected overload .....	133
E.5.3	Concentration of under-loaded Bd-channels.....	133
E.6	Modifications to the main part of the specification .....	133
E.6.1	General interface architecture .....	133
E.6.2	Data transfer .....	133
E.6.3	Load sharing.....	133
E.6.4	Bd-inband signalling .....	134
E.6.5	Switchover and concentration procedure .....	134
E.6.6	Procedures for data link establishment by the CRF-S .....	134



E.6.7	Bd-channel is cleared .....	134
E.6.8	Call collision on the Bd-channel.....	134
Annex F (normative):	Reset procedures .....	135
F.1	Procedure.....	135
F.2	Coding.....	135
Annex G (informative):	Layer 2 SDL diagrams and state tables .....	137
G.1	SDL diagrams.....	137
G.2	Key to the state transition tables .....	140
G.2.1	Definition of a cell of the state transition table .....	140
G.2.2	Key to the contents of a cell.....	140
G.3	State transition tables.....	140
Annex H (normative):	Coding of the BC and LLC information element.....	142
H.1	BC information element for circuit switched bearer capability.....	142
H.2	LCC information element for case A services.....	143
H.3	BC information element for packet mode bearer capability .....	144
H.3.1	BC for Bb-channel establishment .....	144
H.3.2	BC for Bd-channel establishment .....	144
H.4	BC information element in the Bd-channel signalling link .....	145
Annex J (informative):	SDL for management frame continuity check .....	146
Annex K (normative):	Maintenance Flow for PMBS provided on the D-channel.....	150
K.1	General.....	150
K.2	Applicability.....	150
K.3	Coding principles.....	150
K.3.1	Maintenance frame layouts.....	150
K.3.2	Message format .....	151
K.3.2.1	Loop request .....	151
K.3.2.2	Loop response.....	152
K.3.3	Information elements coding.....	152
K.3.3.1	Message type .....	152
K.3.3.2	Loop originator .....	153
K.3.3.3	Loop destination .....	153
K.3.3.4	Diagnostic.....	154
K.3.3.5	Test data .....	154
K.4	Procedures .....	154
K.4.1	General .....	154
K.4.2	Loop procedure.....	155
K.4.2.1	Loop request message generation by the packet handler .....	155
K.4.2.2	Loop request message relaying .....	156
K.4.2.3	Loop request message reception by the requested loop destination .....	156
K.4.2.4	Loop response message generation by the actual loop destination .....	156
K.4.2.5	Loop response message relaying .....	156
K.4.2.6	Loop message reception by the packet handler.....	157
K.4.2.7	Time-out of the loop timer .....	157
K.4.2.8	Loop timer value.....	157

K.4.3	Forward compatibility procedures .....	157
Annex L (normative):	Support of PTNs .....	158
L.1	PTN with CS or D-FH .....	158
L.2	PTN with PH .....	158
L.3	PTN with PHI-FH .....	158
L.3.1	Reference configuration .....	159
L.3.2	Services.....	159
L.3.2.1	Semi-permanent Bd-channel.....	159
L.3.2.2	Demand Bd-channel, long duration .....	159
L.3.3	Signalling.....	159
History	.....	160

## Foreword

This Draft European Telecommunication Standard (ETS) has been prepared by the Network Aspects (NA) Technical Committee of the European Telecommunications Standards Institute (ETSI), and is now submitted for the Public Enquiry phase of the ETSI standards approval procedure.

In accordance with CCITT Recommendation I.130 [1], the following three level structure is used to describe the telecommunications services by European public telecommunications operators under the pan-European Integrated Services Digital Network (ISDN):

- Stage 1: is an overall service description, from the user's standpoint;
- Stage 2: identifies the functional capabilities and information flows needed to support the service described in stage 1; and
- Stage 3: defines the signalling system protocols and switching functions needed to implement the service described in stage 1.

This ETS defines a network-internal interface for the provision of ISDN packet mode services as defined in ETS 300 048 [7] (derived from CCITT Recommendation I.232 [16]), ETS 300 049 [8] (derived from CCITT Recommendation I.232 [16]) (stage 1) and ETS 300 007 [20] (derived from ITU-T Recommendation X.31 [19]) (stage 3).

In addition, this ETS defines the network-internal interface for the provision of packet services in Global System for Mobile communication (GSM) Public Land Mobile Networks (PLMNs) (see ETS 300 603 [21]).

- NOTE 1: The term ISDN packet mode services is used in a way as to include both case B (ISDN Packet Mode Bearer Services (PMBSs)) and case A (PSPDN services), see ETS 300 007 [20].
- NOTE 2: No stage 2 service description existed at the time this ETS was prepared.
- NOTE 3: The PLL service described in ETS 300 049 [8] and supported by this ETS is not explicitly mentioned in ETS 300 007 [20].
- NOTE 4: For case A services described in ETS 300 007 [20] and supported by this ETS, no stage 1 service description exists.

<b>Proposed transposition dates</b>	
Date of latest announcement of this ETS (doa):	3 months after ETSI publication
Date of latest publication of new National Standard or endorsement of this ETS (dop/e):	6 months after doa
Date of withdrawal of any conflicting National Standard (dow):	6 months after doa

## Overview of the main changes from edition 1 of this ETS

Following is a list of main technical changes from edition 1 of this ETS. Other editorial changes have also been made during the creation of this second edition, details are not given here:

- use of the PHI for PLMN (clause 1);
- removal of the detailed selection mechanism for incoming calls (subclause 5.3.3 and former annex K);
- alignment with ETS 300 048 edition 2 and ETS 300 049 edition 2, including the new long duration PLL and switched long duration B-channel access methods (subclauses 5.1 and 5.4, table 57);
- relaxation of Bd-channel loading criteria (subclauses 6.3.3.1 and 8.3.2.2.2, former 12.4.3.3);
- both-way management frame continuity check procedures becomes default (subclause 9.7);
- corrections in the PLL and semi-permanent access method registration procedures and formats (subclause 11.4, table 49);
- exception reporting in the Bd-channel (subclauses 12.3.1.3, 12.4.2.2 and 12.4.1.2);
- the "Additional subscriber identity" information element contains the TEI (tables 45 and 54);
- annex E (Switchover and concentration procedures) becomes normative (but optional);
- annex F (Reset procedures) becomes normative (but optional);
- corrections in management frame continuity check SDLs (annex J);
- management flow procedures (new annex K);
- support of Private Telecommunication Networks (PTNs), including Bd-channels between PTN and Packet Handler (PH) (new annex L).

## 1 Scope

### **Implementation alternatives for ISDN packet mode services and applicability of this European Telecommunication Standard (ETS).**

This ETS defines a network-internal interface for the provision of ISDN packet-mode services.

The term ISDN packet mode services is defined in such a way as to include both case B (ISDN Packet Mode Bearer Services (PMBS)), and case A (PSPDN services), as defined in ETS 300 007 [20].

If a specific implementation alternative for the provision of PMBS and PSPDN is used in an ISDN or a Global System for Mobile communication (GSM) Public Land Mobile Network (PLMN), this ETS applies. The implementation alternatives and the exact location of the interface are described below.

In CCITT Recommendation I.324 [6] local Connection Related Function (CRF) and Packet-Handling Function (PHF) are defined as being involved in the provision of PMBS. The local CRF includes the Exchange Termination (ET). Two basic implementation alternatives are mentioned in subclause 3.1.2 of CCITT Recommendation I.324 [6] and in ETS 300 007 [20]:

- 1) the PHF is integrated in the local CRF; and
- 2) the PHF is not part of the local CRF.

NOTE 1: Local CRF and PHFs are implemented with different physical equipment and in a multi-vendor environment. In addition, the Packet Handler (PH), although logically belonging to the ISDN, may be physically part of the PSPDN.

In the first case, the interface between ET and PHFs can be kept internal and proprietary. In the second case, a standardized interface between local CRF and PHFs is required. This ETS defines a manufacturer-independent interface between the local CRF and PHFs. The interface is called the Packet Handler access point Interface (PHI).

If the second implementation alternative is chosen for the provision of packet mode services in an ISDN, this ETS applies for the implementation of the PHI. The existence of this ETS does, however, not preclude the choice of the first implementation alternative in an ISDN.

Considerations for the use of the PHI in private networks and interworking between private and public networks are outside the scope of this ETS. The PHI is a network-internal interface to be used in public networks.

### **ISDN packet mode services supported**

The full scope of services defined in ETS 300 048 [7] and ETS 300 049 [8] (case B) and in ETS 300 007 [20] (cases A and B) is supported by the PHI specification, see clause 5 for details. Subclause 5.4 contains a table giving an overview of the services, references to the relevant sections of the PHI specification and a conformance statement.

The PHI specification uses the term Packet Handler (PH) in both case A and case B services. For case A services, the PH assumes the role of the Access Unit (AU), see ETS 300 007 [20].

No other services are supported by the PHI specification.

## Local and remote access to the PHI

The PHI denotes the interface between the PH and the CRF it is directly connected to (called CRF-P, see subclause 4.3). At least in the initial phase of service offerings it can be expected that the number of local exchanges in an ISDN exceeds the number of packet handlers. The PHI will thus also have to support subscribers accessing it remotely, i.e. subscriber and PH are connected to different CRFs.

Consequently the following two scenarios are considered in this specification:

1) Local PHI Access:

An ISDN subscriber accessing packet mode services from the PH is directly connected to the CRF-P.

2) Remote PHI Access:

An ISDN subscriber accessing packet mode services from the PH is connected to the CRF-P via another local CRF (called CRF-S, see subclause 4.3) or series of CRFs (CRF-S and transit-CRFs).

In the second scenario the PHI specification defines only the interface between PH and CRF-P. The interface between CRF-S and CRF-P is thus not defined by the PHI specification.

NOTE 2: Requirements by the PHI specification on the common channel signalling system (signalling between CRF-S and CRF-P) are described in (informative) annex A.

## 2 Normative references

This ETS incorporates, by dated or undated reference, provisions from other publications. These normative references are cited at the appropriate places in the text and the publications are listed hereafter. For dated references subsequent amendments to, or revisions of any of these publications apply to this ETS only when incorporated in it by amendment or revision. For undated references the latest edition of the publication referred to applies.

- [1] CCITT Recommendation I.130 (1988): "General arrangements for interworking between PSPDNs and ISDNs for the provision of data services".
- [2] ITU-T Recommendation Q.932 (1993): "Digital subscriber Signalling System No. 1 (DSS 1) - Generic procedures for the control of ISDN supplementary services".
- [3] ITU-T Recommendation X.32 (1993): "Interface between DTE and DCE for terminals operating in the packet mode and accessing a packet switched public data network through a public switched telephone network or an integrated services digital network or a circuit switched public data network".
- [4] ITU-T Recommendation X.25 (1993): "Interface between Data Terminal Equipment (DTE) and Data Circuit-terminating Equipment (DCE) for terminals operating in the packet mode and connected to public data networks by dedicated circuit".
- [5] CCITT Recommendation X.121 (1992): "International numbering plan for public data networks".
- [6] CCITT Recommendation I.324 (1991): "ISDN network architecture".
- [7] ETS 300 048 (1995): "Integrated Services Digital Network (ISDN); ISDN Packet Mode Bearer Services (PMBS) ISDN Virtual Call (VC) and Permanent Virtual Circuit (PVC) bearer services provided by the B-channel of the user access-basic and primary rate".

- [8] ETS 300 049 (1995): "Integrated Services Digital Network (ISDN); Packet Mode Bearer Service (PMBS) ISDN Virtual Call (VC) and Permanent Virtual Circuit (PVC) bearer services provided by the D-channel of the user access - basic and primary rate".
- [9] CCITT Recommendation E.165 (1988): "Timetable for coordinated implementation of the full capability of the numbering plan for the ISDN era (CCITT Recommendation E.164)".
- [10] ETS 300 402-2 (1990): "Integrated Services Digital Network (ISDN); Digital Subscriber Signalling System No. one (DSS1) protocol; Data link layer; Part 2: General protocol specification [ITU-T Recommendation Q.921 (1993), modified]".
- [11] ETS 300 403-1 (1990): "Integrated Services Digital Network (ISDN); Digital Subscriber Signalling System No. one (DSS1) protocol; Signalling network layer for circuit-mode basic call control; Part 1: Protocol specification [ITU-T Recommendation Q.931 (1993), modified]".
- [12] CCITT Recommendation I.412 (1988): "ISDN User-network interfaces; Interface structures and access capabilities".
- [13] CCITT Recommendation E.164 (1988): "Numbering plan for the ISDN era".
- [14] CCITT Recommendation X.122 (1992): "Numbering plan interworking for the E.164 and X.121 numbering plans".
- [15] CCITT Recommendation E.166 (1992): "Numbering plan interworking for the E.164 and X.121 numbering plans".
- [16] CCITT Recommendation I.232 (1988): "Packet mode bearer services categories".
- [17] CCITT Recommendation X.75 (1993): "Packet-switched signalling system between public networks providing data transmission services".
- [18] ETS 300 011 (1992): "Integrated Services Digital Network (ISDN); Primary rate user-network interface Layer 1 specification and test principles".
- [19] ITU-T Recommendations X.31/I.462 (1992): "Support of packet mode terminal equipment by an ISDN".
- [20] ETS 300 007 (1991): "Integrated Services Digital Network (ISDN); Support of packet-mode terminal equipment by an ISDN".
- [21] ETS 300 603: "European digital cellular telecommunications system (Phase 2); Interworking between a Public Land Mobile Network (PLMN) and a Packet Switched Public Data Network/Integrated Services Digital Network (PSPDN/ISDN) for the support of packet switched data transmission services (GSM 09.06)".
- [22] ITU-T Recommendation Q.850 (1993): "Use of cause and location in the digital subscriber signalling system No. 1 and the Signalling System No. 7 ISDN user part".

### 3 Definitions and abbreviations

#### 3.1 Definitions

For the purpose of this ETS, the following definitions apply:

NOTE 1: For each of the definitions below, the section where it appears in the main text is indicated in brackets. The definitions are listed according to the order of their appearance in the main text.

**ISDN Packet mode services (1.1):** The term ISDN packet mode services is defined in such a way as to include both case B (ISDN packet mode bearer services, PMBS), and case A (PSPDN services), see ETS 300 007 [20].

**Local PHI Access (1.3, 6.2.1):** An ISDN subscriber accessing packet mode services is directly connected to the CRF-P, i.e. CRF-P equal to CRF-S.

**Remote PHI Access (1.3, 6.2.2):** An ISDN subscriber accessing packet mode services is connected to the CRF-P via a CRF-S.

**PHI Operations, Administration and Maintenance (OA&M) (4.2, 8.1.1):** The PHI specification deals only with those PHI related OA&M aspects, that require the coordination of CRF-P/S and PH. These aspects are called "PHI OA&M". OA&M requirements that are local to the CRF-P/S side or the PH side of the PHI are not within its scope.

**CRF-P (4.3):** CRF physically connected to the PH.

**CRF-S (4.3):** CRF to which subscribers are connected.

**Outgoing Call (5, 10):** Direction from CRF-S (CRF-P) to PH.

**Incoming Call (5, 10):** Direction from PH to CRF-P (CRF-S).

**Bb-Channel (6.1):** A B-channel of the PRA used for the support of user B-channel services.

**Bd-Channel (6.1):** A B-channel of the PRA used for the support of user D-channel services.

**Bundle (6.2):** A bundle denotes all Bd-channels of a PHI leading to a particular CRF-S.

**Sub-bundle (6.2):** A sub-bundle denotes all Bd-channels of a PHI leading to a particular Frame Handler (FH) within the CRF-S.

NOTE 2: In case of a centralized FH a sub-bundle is identical to a bundle.

**Centralized FH Architecture (6.2):** A CRF-S has a centralized FH architecture, if the PH sees only one FH within this CRF-S.

**Decentralized FH Architecture (6.2):** A CRF-S has a decentralized FH architecture, if the PH sees more than one FH within the CRF-S.

**Administrative Procedures (8.1.2):** These PHI OA&M procedures are separately activated on both sides of the interface. Synchronization is not automated, i.e. consistency has to be ensured externally. No signalling on the PHI is involved.

**Dynamic Procedures (8.1.2):** These PHI OA&M procedures are activated by only one side of the PHI, and the activation is transferred to the other side by the means of PHI signalling. Consistency is thus ensured automatically.



**Provisioning (8.1.2):** Procedures for the establishment of semi-permanent channels and semi-permanent links or Preallocated Logical Links (PLLs) are called "provisioning".

**Static Provisioning (8.1.2):** Provisioning done using administrative procedures.

**Dynamic Provisioning (8.1.2):** Provisioning done using dynamic procedures.

**Timer TCC (9.7):** PHI specific timer for layer 2 protocol on the Bd-channels.

**Timers TPHI, TPH, TCRF (10.7):** PHI specific timers used with PHI signalling.

### 3.2 Abbreviations

For the purpose of this ETS, the following abbreviations apply:

AIS	Alarm Indication Signalling
AU	Access Unit
BC	Bearer Capability
CRF	Connection Related Function
DDI	Direct Dialling In
DLCI	Data Link Connection Identifier
DTE	Data Terminal Equipment
ET	Exchange Termination
FH	Frame Handler
FR	Frame Relaying
FS	Frame Switching
GSM	Global System for Mobile communication
HDLC	High level Data Link Control procedure
IWF	Interworking Function
LAPB	Link Access Procedure Balanced
LAPD	Link Access Procedure on the D-channel
LIC	Link Identification Code
LLC	Low Layer Compatibility
MSN	Multiple Subscriber Number
NPI	Numbering Plan Identification
NT2	Network Termination 2
NUI	Network User Identification
OA&M	Operations, Administration and Maintenance
OSI	Open Systems Interconnection
PH	Packet Handler
PHF	Packet Handling Function
PHI	Packet Handler access point Interface
PLL	Preallocated Logical Link
NOTE: PLL was called "Permanent Logical Link" in edition 1 of this ETS.	
PLMN	Public Land Mobile Network
PMBS	Packet Mode Bearer Service
PRA	Primary Rate Access
PSPDN	Packet Switched Public Data Network
PTN	Private Telecommunication Network
PVC	Permanent Virtual Circuit
RAI	Remote Alarm Indication
SAPI	Service Access Point Identifier
(S)VC	(Switched) Virtual Call
TA	Terminal Adapter
TCR	Channel Reset Timer
TE	Terminal Equipment (TE1 or TE2 + TA)
TE1	Terminal Equipment type 1
TE2	Terminal Equipment type 2
TEI	Terminal Endpoint Identifier
TOA	Type Of Address
UNI	User Network Interface
X.25PLP	ITU-T Recommendation X.25 [4] Packet Layer Procedures

## 4 Reference configuration and functional model

### 4.1 Reference configuration

Reference configurations involving the ISDN packet mode connection type can be found in ETS 300 007 [20], and CCITT Recommendation I.324 [6] and ITU-T Recommendation X.31 [19].

CCITT Recommendation I.324 [6] defines two ISDN functional entities, "local connection related function" (local CRF) and "packet switching functional entities" (Packet Handler/Interworking Function (PH/IWF)). The PHI is located between these two functional entities.

The PHI specification uses the term packet handler (PH) in both case A and case B services. For case A services, the PH assumes the role of the Access Unit (AU) as described in ETS 300 007 [20].

Figure 1 gives the reference configuration which forms the basis for the standardization of the PHI.

For case B, the connection between the ISDN subscriber and the CRF-P shall not cross ISDN network boundaries.

NOTE 1: If ITU-T Recommendation X.75 [17] is chosen as the protocol between PH and PSPDN, the PSPDN does not extend into the ISDN. If, on the other hand, an internal network protocol is used between PH and the PSPDN, the PSPDN and the packet switching part of the ISDN may be viewed as a single entity.

NOTE 2: In the case that the PHI supports case A services in addition to case B the PH assumes the role of the Access Unit (AU).

NOTE 3: The user arrangement shown in figure 1 is only an example. For other possibilities refer to ETS 300 007 [20].

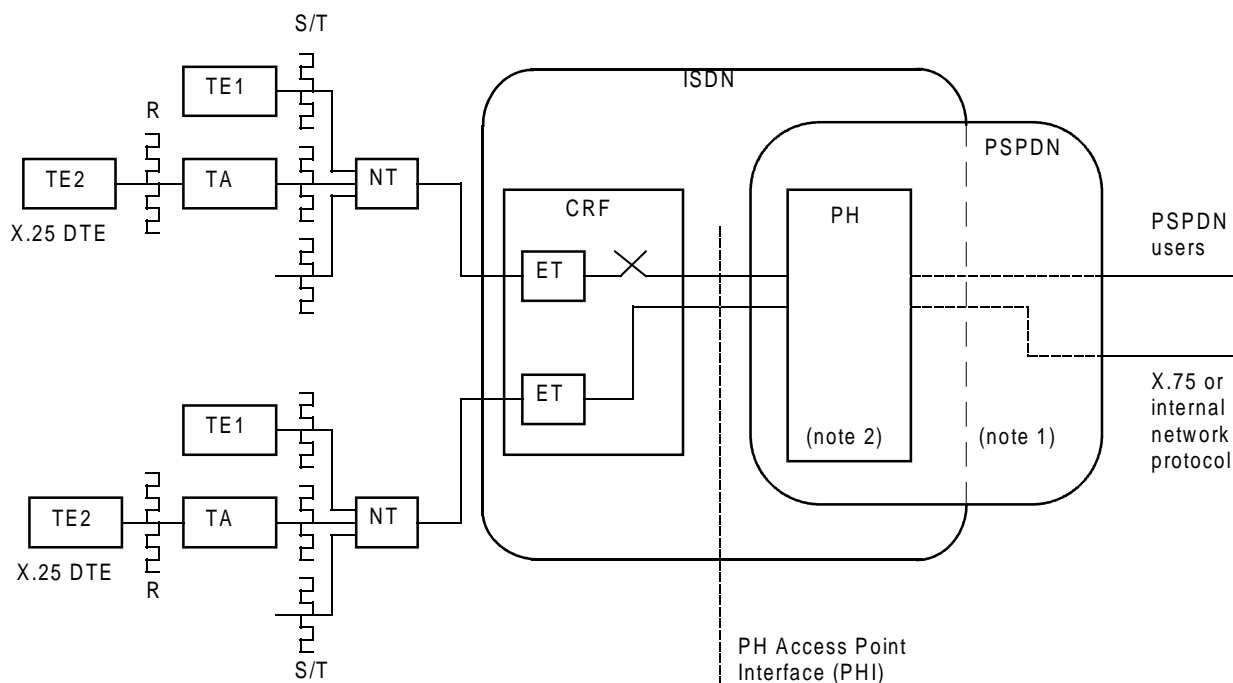


Figure 1: Reference configuration for the PH access point Interface (PHI)

## 4.2 Basic functional model

Figure 2 gives the basic functional model for the PHI.

The following functions related to the PHI can be identified and located:

In the local Connection Related Function (CRF):

**Switching matrix:** Circuit switching capability of the local exchange, being used primarily for connecting subscriber B channels used for packet mode services.

NOTE: The switching matrix is also involved in the support of D-channel services.

**Frame handler (FH):** Layer 2 functionality for multiplexing subscriber D-channel links used for packet mode services (Service Access Point Identifier = 16 (SAPI=16)) onto channels of the PHI.

**PHI signalling:** Signalling functionality across the PHI. This includes call control and interface management functions.

**CRF-related OA&M functions (CRF OA&M):** OA&M functionality related to the subscriber connection (e.g. administration of user profile data related to the connection and to circuit switching services).

**PHI OA&M:** OA&M functionality related to the PHI, see subclause 8.1.1.

The local (CRF) may be physically distributed.

In the Packet Handler Function (PHF):

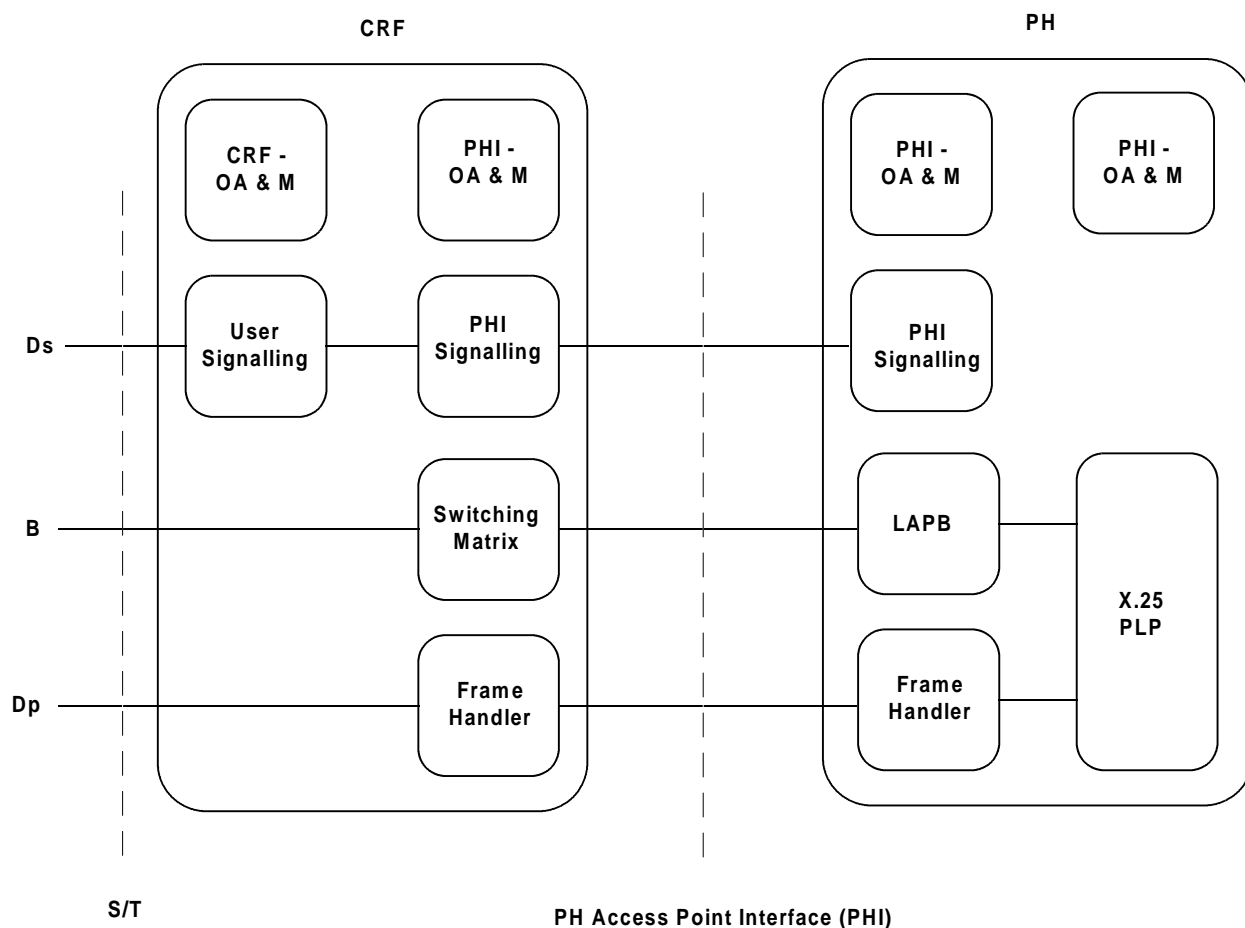
**Frame Handler (FH):** Layer 2 functionality for multiplexing subscriber D-channel links used for packet mode services (SAPI=16) onto channels of the PHI.

**PHI signalling:** Signalling functionality across the PHI. This includes call control and interface management functions.

**ITU-T Recommendations X.25/Link Access Procedure Balanced (LAPB) and X.25/Link Access Procedure on the D-channel (LAPD):** Layer 2 and layer 3 protocol support for subscriber B and D-channel packet mode services.

**PH-related OA&M functions (PH OA&M):** OA&M functionality related to packet switching services (e.g. administration of user profile data related to packet switching services).

**PHI OA&M:** OA&M functionality related to the PHI, see subclause 8.1.1.



**Explanation:**

Ds: Signalling on the D-channel.  
 Dp: Packet data on the D-channel.

NOTE: Not all functions may be required.

**Figure 2: Basic functional model for the PHI**

**4.3 Functional model for remote access to the PHI**

The following terminology will be used to describe the remote access situation:

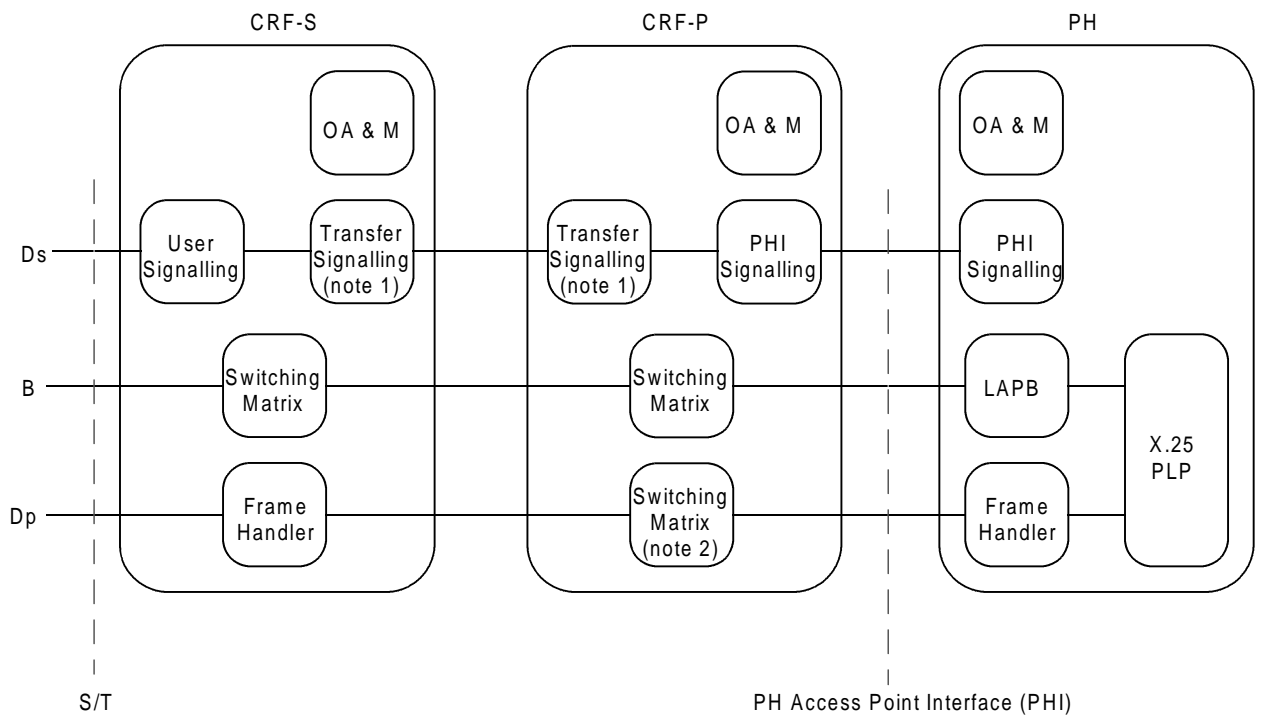
CRF-P: CRF physically connected to the PH.  
 CRF-S: CRF to which subscribers are connected.

In the case where a subscriber accesses a PH locally (local PHI access, see clause 1), CRF-S and CRF-P are identical. In the other case, where a subscriber accesses the PHI remotely, i.e. the PH is not connected to the same CRF as the subscriber, CRF-S and CRF-P are different and may be physically separated by other CRFs (transit-CRFs).

The functional model for remote access to the PHI is given in figure 3.

The CRF-P as well as the CRF-S may be physically distributed.

NOTE: As an example, remote subscriber units or ISDN multiplexers can be considered as part of the CRF-S.



Ds: Signalling on the D-channel.  
Dp: Packet data on the D-channel.

NOTE 1: This function is not required where the PHI signalling function is placed in the CRF-S and the information is carried transparently through the CRF-P to the PH.

NOTE 2: This function could be replaced by a FH in case of statically provisioned semi-permanent links or PLLs.

NOTE 3: Not all functions may be required.

**Figure 3: Functional model for remote access to the PHI**

## 5 Services supported by the PHI specification

The services supported by the PHI specification are those defined by ETS 300 048 [7] (B-channel, case B), ETS 300 049 [8] (D-channel, case B) and ETS 300 007 [20] (B-channel case A), see clause 1.

Considering the complexity of these ISDN packet mode services, this clause gives a synoptic description of these services in order to form an unambiguous basis for the description and understanding of the PHI. Wherever possible, references are made to ETSI service specifications. Specific implications for the PHI, however, are highlighted, and clarifications are made where necessary.

The PHI may be used to offer a subset of the services in this specification.

### 5.1 Basic service aspects

This specification covers both case A services and case B services, and for the latter one, both B and D-channel access. All access methods are applicable to both point-to-multipoint (e.g. passive bus) and point-to-point (e.g. NT2) ISDN access configurations, and to both basic and primary rate user access.

A subscriber shall see identical services from the PH and use the same signalling procedures, regardless of whether he accesses the PHI locally or remotely, i.e. whether CRF-P and CRF-S are identical or not.

NOTE: For case A, different implementations in parallel to and not conforming to the PHI may be used as a continuation of existing case A implementations.

### 5.1.1 Services provided on the B-channel

Services provided on the B-channel can be offered and supported by the PHI either according to case A, case B or both. A transparent 64 kbit/s physical connection is used between the user Terminal Equipment (TE) and the PH. On layer 2, ITU-T Recommendation X.25 [4].Link Acces Procedure Balanced (LAPB) are employed, and on layer 3, ITU-T Recommendation X.25 [4] packet layer procedures are employed.

NOTE: For case A, switched access, the link layer address assignment is done as defined in ITU-T Recommendation X.32 [3].

Rate adaption for case A and case B is according to the High level Data Link Control procedure (HDLC) inter-frame flag stuffing principle, see ETS 300 007 [20], subclause 8.3.2.

All three B-channel access methods, as defined in ETS 300 048 [7] (for case B) and in ETS 300 007 [20] (for case A), may be supported by the PHI : semi-permanent B-channel, switched B-channel and switched long-duration B-channel access.

#### 5.1.1.1 Semi-permanent B-channel access

The semi-permanent B-channel access connection between the TE and the PH is permanently available, independent of ITU-T Recommendation X.25 [4] Virtual Calls/Permanent Virtual Circuits (VCs/PVCs). The network is responsible to establish and maintain the connection.

The layer 1 is kept permanently active by the CRF-S. The B-channel connection is (re)established by means of administrative procedures in CRF-S, CRF-P, PH and transit ISDN nodes, without the use of ETS 300 403-1 [11] procedures. The data link is (re)established by means of ITU-T Recommendation X.25 [4] LAPB procedures under responsibility of the PH.

Both Virtual Calls and Permanent Virtual Circuits are supported.

For this access method, the subscriber is registered with the PH. Customized and standard service profiles can be used, see definitions in subclause 3.1.

#### 5.1.1.2 Switched B-channel access

The switched B-channel access connection between the TE and the PH is established (released) on-demand by either the user or network, depending on the first/last ITU-T Recommendation X.25 [4] VC using this channel.

The layer 1 can be permanently activated by the CRF-S or activated on-demand by the user or CRF-S. The B-channel connection is established (released) by means of ETS 300 403-1 [11] procedures initiated by the user or PH. The data link is established (released) by means of ITU-T Recommendation X.25 [4] LAPB procedures initiated by the user or PH.

Only Virtual Calls are supported.

For case B, subscription to or general availability of the switched B-channel access method implies in the CRF-S subscription to or general availability of the basic service PMBS-B. When the switched B-channel access method is available on a general basis, the subscriber need not be registered with the PH and can thus have the default service profile. Otherwise a customized or standard service profile can be used.

#### 5.1.1.3 Switched long-duration B-channel access (case B)

The switched long-duration B-channel access connection between the TE and the PH is established (released) on-demand by the user, independent of ITU-T Recommendation X.25 [4] VC/PVCs.

The layer 1 can be permanently activated by the CRF-S or activated on-demand by the user. When PVCs are supported, the layer 1 shall be permanently active. The B-channel connection is established (released) by means of ETS 300 403-1 [11] procedures initiated by the user. The data link is established

(released) by means of ITU-T Recommendation X.25 [4] LAPB procedures initiated by the user. Also the PH may establish the data link.

Both Virtual Calls and Permanent Virtual Circuits are supported.

Subscription to the switched long-duration B-channel access method implies in the CRF-S subscription to the basic service PMBS-B. For this access method, the subscriber is registered with the PH. Customized and standard service profiles can be used but in the case of PVC service, the user needs to have a customized service profile.

### **5.1.2 Services provided on the D-channel (case B)**

Services provided on the D-channel can only be offered and supported by the PHI according to case B. A LAPD datalink connection is used between the user and the PH. On layer 2, LAPD procedures according to ETS 300 402-2 [10] are used. On layer 3, ITU-T Recommendation X.25 [4] packet layer procedures are used. The maximum packet size is 256 octets since the information field of LAPD frames is restricted to 260 octets.

D-channel packet datalinks from multiple users are multiplexed on 64 kbit/s channels (Bd-channels, see subclause 6.3.3) that are established between the CRF-S and the PH. Whereas the packet datalinks on the user's D-channel are distinguished by their TEI value, they are identified by a Link Identification Code (LIC) value (see subclause 9.2) on the Bd-channels between CRF-S and PH.

All four D-channel access methods as defined in ETS 300 049 [8] may be supported by the PHI: semi-permanent D-channel, preallocated logical link (PLL), long-duration preallocated logical link and switched D-channel access.

#### **5.1.2.1 Semi-permanent D-channel access**

The semi-permanent D-channel access connection between the TE and the PH is permanently available, independent of ITU-T Recommendation X.25 [4] VC/PVCs. The network is responsible to establish and maintain the datalink connection.

The layer 1 is kept permanently active by the CRF-S. The LAPD datalink connection between user and PH is (re)established by means of ETS 300 402-2 [10] procedures initiated by the PH. Layer 2 addresses at the user-network interface (TEI) as well as on the Bd-channel(s) between CRF-S and the PH (LIC) are allocated at subscription time.

Both Virtual Calls and Permanent Virtual Circuits are supported.

For this access method, the subscriber is registered with the PH. Customized and standard service profiles can be used.

#### **5.1.2.2 PLL access**

The Preallocated Logical Link (PLL) access connection between the TE and the PH is established (released) on demand by the user or network, depending on the first/last VC using this connection.

The layer 1 can be permanently activated by the CRF-S or activated on-demand by the user or CRF-S. The LAPD datalink connection between user and PH is established (released) by means of ETS 300 402-2 [10] procedures initiated by the user or PH. Layer 2 addresses at the user-network interface (TEI) as well as on the Bd-channel(s) between CRF-S and the PH (LIC) are allocated at subscription time.

Only Virtual Calls are supported.

For this access method, the subscriber is registered with the PH. Customized and standard service profiles can be used.

### 5.1.2.3 Long duration PLL access

The Long duration Preallocated Logical Link (PLL) access connection between the TE and the PH is established (released) on demand by the user, independent of ITU-T Recommendation X.25 [4] VC/PVCs.

The layer 1 can be permanently activated by the CRF-S or activated on-demand by the user. When PVCs are supported, the layer 1 shall be permanently active. The LAPD datalink connection between user and PH is established (released) by means of ETS 300 402-2 [10] procedures initiated by the user. Layer 2 addresses at the user-network interface (TEI) as well as on the link(s) Bd-channel(s) between CRF-S and the PH (LIC) are allocated at subscription time.

Both Virtual Calls and Permanent Virtual Circuits are supported. For PVCs, the user is responsible to keep the datalink connection permanently established.

For this access type method, the subscriber is registered with the PH. Customized and standard service profiles can be used but in case of the PVC service, the user shall have a customized service profile.

### 5.1.2.4 Switched D-channel access

The switched D-channel access connection between the TE and the PH is established (released) on-demand by either the user or network, depending on the first/last ITU-T Recommendation X.25 [4] VC using this connection.

The layer 1 can be permanently activated by the CRF-S or activated on-demand by the user or CRF-S. The LAPD datalink connection between user and PH is established (released) by means of ETS 300 402-2 [10] procedures initiated by the user. Layer 2 addresses at the user-network interface (TEI) as well as on the link(s) Bd-channel(s) between CRF-S and the PH (LIC) are assigned at link activation time. In the case of incoming calls, ETS 300 403-1 [11] call offering procedures may be used to notify the subscriber.

Only Virtual Calls are supported.

Subscription or general availability of the switched D-channel access method implies in the CRF-S subscription to or general availability of the basic service PMBS-D. When the switched D-channel access method is available on a general basis, the subscriber need not be registered with the PH and can thus have the default service profile. Otherwise a customized or standard service profile can be used.

### 5.1.3 Subscription and related data

The subscription data, defined in ETS 300 048 [7] and ETS 300 049 [8], are distributed among CRF-S and PH. A subscription may also require some PHI specific registration data, as specified in clause 8. Table 0A summarises the location of the subscription data and its corresponding PHI specific registration data. This table does not show network defined data (like layer 2 parameters) or service data defined during service invocation (like Bd-channel reference).

The CRF-S makes no distinction between the switched and the switched long duration B-channel access methods, except that layer 1 is kept permanently active when PVCs are supported on a switched long duration B-channel access. Similarly, it does not distinguish between the PLL and the long duration PLL access methods. Since this distinction has little relevance on the PHI, the terms "switched B-channel" and "PLL" will be used in this ETS to refer to the corresponding long duration access methods as well, unless when used in a context where explicit distinction with the long duration access method is made.



**Table 0A: Location of subscription and related data per access method for remote PHI access**

	<b>CRF-S</b>	<b>CRF-P</b>	<b>PH</b>
For all access methods	Access method		Access method Notification class X.25 service profile E.164/X.121 number
Semi-permanent B-channel	UNI access, time slot transit access, time slot	transit access, time slot PHI access, time slot	PHI access, time slot
Switched long duration B-channel	E.164 number		Maximum number of connections N
Switched B-channel	(note)		Maximum number of connections N
Semi-permanent D-channel	UNI access, TEI, FH reference, LIC (note)		CRF-S identity, FH reference, LIC
Long duration PLL			CRF-S identity, FH reference, LIC
PLL			CRF-S identity, FH reference, LIC
Switched D-channel	E.164 number		CRF-S identity
<p>NOTE: The CRF-S makes no distinction between these access methods.</p> <p>UNI: User Network Interface. E.164: CCITT Recommendation E.164 [13]. X.25: ITU-T Recommendation X.25 [4]. X.121: CCITT Recommendation X.121 [5].</p>			

## 5.2 Detailed service aspects

### 5.2.1 Notification of incoming calls

ETS 300 048 [7] (B-channel case B), ETS 300 049 [8] (D-channel case B) and ETS 300 007 [20] (B-channel case A) define two classes in terms of ETS 300 403-1 [11] procedures to notify the user of incoming ITU-T Recommendation X.25 [4] calls (see also ETS 300 007 [20] subclauses 4.1.4 (case A) and 4.2.3 (case B)). These are the No Notification Class and the Conditional Notification Class. These classes are supported by the PHI specification.

NOTE: ITU-T Recommendation X.31 [19] also mentions the Unconditional Notification Class. Unconditional notification is not required by ETSI stage 1 descriptions, and is therefore not supported by the PHI.

#### 5.2.1.1 No Notification Class

The No Notification class applies to all access methods defined in subclause 5.1.

If the access connection (layer 1 and 2) between the PH and the called TE is not established at the time the PH receives an incoming call, the PH will clear the call, or, in the case of PLL initiate the establishment of a logical link before delivering the call.

#### 5.2.1.2 Conditional Notification Class

The Conditional Notification Class applies only to the switched B-channel and the switched D-channel access.

B/D channel selection by the subscriber is not required by ETSI stage 1 descriptions and is therefore not supported by the PHI.

### 5.2.2 Mapping of information elements

In the case of the conditional notification class, some of the information present in the ITU-T Recommendation X.25 [4] Incoming Call Packet shall be mapped into the ETS 300 403-1 [11] SETUP message, see ETS 300 007 [20], subclause 4.2.3.4. For case B, mapping of the following ITU-T Recommendation X.25 [4] information elements is supported by the PHI:

- called address;
- called address extension;
- calling address;
- calling address extension.

The mapping of these elements to corresponding ETS 300 403-1 [11] SETUP message information elements is defined in table 5 of ETS 300 007 [20]. Mapping of other information elements is not applicable according to ETS 300 007 [20] and therefore not supported by the PHI.

NOTE: In ETS 300 007 [20] only mapping of called address and called address extension is defined as mandatory. The mapping of called/calling address extension may, for an interim period, be restricted by ISDN subaddressing capabilities.

For case A, only mapping of called address shall be provided. The calling party number information element of the SETUP message shall contain the ISDN address of the PH.

### 5.2.3 Access connection release

Access connection release may be initiated by either the TE or the PH.

Releasing is initiated by the PH upon expiry of timer T320 (defined in ETS 300 403-1 [11]). The conditions for starting timer T320 are defined in subclause 7.3.2 of ETS 300 007 [20]. The use of timer T320 is supported by the PHI for switched B-channel access (case A and B), switched D-channel access and PLL access.

NOTE: For case A, timer T320 is equivalent to timer T14, defined in ITU-T Recommendation X.32 [3].

The default timeout value for T320 is defined in subclause 10.7.

### 5.2.4 Access collision

Access collision may occur in the case of B-channel access if a ETS 300 007 [20] incoming call is offered to a user, simultaneously with the user requesting a ETS 300 007 [20] outgoing call (i.e. initiating access connection establishment). The PH shall establish both calls independently, using normal call establishment procedures. The user may, if desired, clear either of the calls.

NOTE 1: If both incoming and outgoing calls are treated independently, recognition of a collision situation may not be required and thus the term "access collision" would be inappropriate.

NOTE 2: Procedures for giving priority to the incoming call, as indicated in ETS 300 007 [20], subclause 7.5, which require recognition of access collision are for further study.

### 5.2.5 Cause mappings

The cause mappings (between ETS 300 403-1 [11] and ITU-T Recommendation X.25 [4]) as defined in ETS 300 007 [20] subclause 7.4.4.2 are supported by the PHI for both case A and case B services.

### 5.3 Numbering, addressing and terminal selection

This subclause describes numbering, addressing and terminal selection aspects in relation to the PHI.

#### 5.3.1 Numbering and addressing

A packet mode TE connected to an ISDN is identified by a number from the ISDN numbering plan (see CCITT Recommendations E.164 [13] and E.165 [9]). Additionally, for case A TE may be assigned a number from the PSPDN numbering plan (see CCITT Recommendation X.121 [5]).

For an interim period, users who have subscribed to services provided on the D-channel may be identified by CCITT Recommendation X.121 [5] numbers, as a network option. CCITT Recommendation X.121 [5] numbers shall be used only in conjunction with the No Notification Class (see subclause 5.2.1.1).

To support ITU-T Recommendation X.25 [4] communication between packet mode TEs using different numbering plans (e.g. CCITT Recommendation X.121 [5] in PSPDN and CCITT Recommendation E.164 [13] in ISDN), numbering plan interworking is required. Procedures for numbering plan interworking are defined in CCITT Recommendations E.166 [15] and X.122 [14].

Addressing procedures for access connection establishment are defined in ETS 300 007 [20] (user-network interface).

In the case of outgoing calls, the following addressing information are contained in the SETUP message across the PHI:

- calling party number information element (calling user CCITT Recommendation E.164 [13] number which is verified, or if necessary, inserted by the CRF-S). This information may be used by the PH for charging purposes and service profile selection;
- calling party sub-address information element, if provided by the calling TE. This information may be used by the PH for service profile selection;
- called party number information element may be provided in some cases (case A in conjunction with Direct Dialling In (DDI)).

NOTE 1: In the case of outgoing D-channel logical link establishment, no ETS 300 403-1 [11] signalling procedures are employed at the user-network interface. Therefore, the user can not signal the calling party number. To support more than one service profile per user D-channel, the calling address in the ITU-T Recommendation X.25 [4] Call Request Packet may be used by the PH for service profile selection.

In the case of incoming calls (call offering), the following addressing information are contained in the SETUP message across the PHI:

- called party number information element (called user CCITT Recommendation E.164 [13] number);
- called party subaddress information element (case B);
- calling party number information element (option, case B);
- calling party subaddress information element (option, case B).

NOTE 2: If the called TE is identified by a CCITT Recommendation X.121 [5] number (case A, customized service), the PH has to perform mapping from the CCITT Recommendation X.121 [5] address to an CCITT Recommendation E.164 [13] number, using a "customized" set of OA&M data.

NOTE 3: Called/calling party subaddress information element is only provided if the called/calling address extension fields are included in the ITU-T Recommendation X.25 [4] incoming call packet. For an interim period, the use of ISDN subaddressing capabilities may be restricted.

### 5.3.2 Terminal selection and compatibility checking

A ITU-T Recommendation X.25 [4] incoming call packet arriving at the PH may either directly result in ITU-T Recommendation X.25 [4] procedures (no notification class or access connection is already established), or result in a ETS 300 403-1 [11] call offering procedure (conditional notification class). In the first case, a packet mode TE is selected by the PH which offers the call directly to it (see subclause 5.2.1). In the latter case, terminal selection will be provided by the user based on information contained in the ETS 300 403-1 [11] SETUP message. Currently, addressing methods are the only possibilities to select among several packet mode TEs in a subscriber installation, i.e. use of Multiple Subscriber Number (MSN) or DDI supplementary services.

Information contained in the ETS 300 403-1 [11] SETUP message are used by the TE for compatibility checking purposes. The following procedures are supported by the PHI:

- for case B services, the Bearer Capability (BC) information element shall indicate transfer mode ("packet mode"), user information layer 2 protocol ("ITU-T Recommendation X.25 [4] LAPB or Q.921") and user information layer protocol ("X.25"). This information is provided for both incoming and outgoing calls;
- for case A services, the Low Layer Compatibility (LLC) information element is used to convey similar information. The LLC shall be provided by the PH in the case of incoming calls, and may be provided by the user in the case of outgoing calls.

### 5.3.3 Directory number and services association

A directory number can be associated with more than one access method. Per access method more than one connection may be established. The following basic principles are identified for access connection or access method selection:

- established/permanent channels/links are used wherever possible.
- D-channel selection is given preference to B-channel, if requested throughput allows this.

### 5.4 Services cross-reference and conformance statement for the PHI

This section gives an overview of the ISDN packet mode services supported by the PHI, and a cross-reference to the procedures that are specifically applicable to specific services. The sections not mentioned in table 0B are applicable to all services or as indicated.

The PHI may be used to offer a subset of the ISDN packet mode services supported by the PHI specification. Conformance to the PHI specification is ensured by conforming to the sections of the specification that are relevant for the support of the subset of ISDN packet mode services to be offered with the PHI (see table 0B).

**Table 0B: Overview of ISDN packet mode services supported by the PHI specification and cross reference to specifically applicable procedures/section**

Access method	Channel establishment	Layer 2 establishment	Packet mode bearer service	PH Registration (note 1)	No Notification (note 2)	Conditional Notification (note 3)	Reference to PHI specification		
Semi-permanent B-channel Case A	Semi-permanent	Semi-permanent	VC/PVC	YES	YES	NO	5.1.1.1 8.2.1.1 (note 4) 11.2 (note 4)		
Switched B-channel Case A	On-demand	On-demand	VC	YES/NO	YES	YES	5.1.1.2 10.2		
Semi-permanent B-channel Case B	Semi-permanent	Semi-permanent	VC/PVC	YES	YES	NO	5.1.1.1 8.2.1.1 (note 4) 11.2 (note 4)		
Switched long duration B-channel Case B	On-demand	On-demand	VC/PVC	YES	YES	NO	5.1.1.3 10.3 (Annex C for PVC-support)		
Switched B-channel Case B	On-demand	On-demand	VC	YES/NO	YES	YES	5.1.1.2 10.3		
Semi-permanent D-channel	N/A	Semi-permanent	VC/PVC	YES	YES	NO	5.1.2.1 11.5 (note 4)	12.4 12.5	6.3.3 7.1
Long duration PLL		On-demand	VC/PVC	YES	YES	NO	5.1.2.3 11.4 (note 4)	12.4 12.5	8.2.1.2 (note 4) 11.3 (note 4)
PLL		On-demand	VC	YES	YES	NO	5.1.2.2 11.4 (note 4)	12.4 12.5	8.3.2 9
Switched D-channel		On-demand	VC	YES/NO	YES	YES	5.1.2.4 8.4.2.2.2, 8.4.2.3.2 10.5 12.3 13		10.4 (note 5) 12.2 (note 5) Annex A(note 5)
NOTE 1:	For unregistered subscribers, only a default service profile can be provided. For registered subscribers, a customized or standard service profile can be provided. The default service profile may be available as a standard service profile in addition.								
NOTE 2:	For this notification class, a subscriber may be identified by a CCITT Recommendation E.164 [13] number, or a CCITT Recommendation X.121 [5] number. The use of CCITT Recommendation X.121 [5] numbers is, however, restricted to case A and D-channel case B services.								
NOTE 3:	For this notification class, a subscriber is always identified by a CCITT Recommendation E.164 [13] number.								
NOTE 4:	Provisioning semipermanent mechanisms for semipermanent Bb-channels, semipermanent Bd-channel links may be provided according to one or more of the methods described in this specification on bilateral agreement.								
NOTE 5:	The provision of switched Bd-channels is optional.								

## 6 Basic interface structure

### 6.1 General

The PHI in the strict sense is the interface between the PH and the directly connecting CRF (CRF-P, see subclause 4.3). Layer 1 is an ISDN primary rate access (PRA) and shall conform to ETS 300 011 [18]. The PH assumes the user side.

A PHI between a pair PH/CRF-P may consist of multiple PRAs. This configuration is described in figure 5 and in subclause 7.2.

The channel structure of a PRA of the PHI is 30B+D (see CCITT Recommendation I.412 [12]). As in a regular PRA, the D64-channel (time slot 16) is reserved for call control signalling for the B-channels of this PRA (see subclause 6.3.1).

NOTE: If only semi-permanent B-channels (Bb and/or Bd-channels) are supported, no D64-channel signalling is required and a PCM-30 system may be used.

B-channels are designated as either Bb- or Bd-channels (see subclause 6.3). Bb-channels support user B-channel packet mode services, whereas Bd-channels support user D-channel packet mode services. In case of switched D-channel access or dynamic provisioning of semi-permanent links or PLLs, one Bd-channel per pair CRF-S/PH carries signalling information for link layer management between this CRF S and the PH in addition.

The distribution of Bb- and Bd-channels on a PRA is determined by bilateral agreement between CRF P and PH. The selection of a particular time slot for a new switched Bb or Bd-channel request is always performed by the PH.

### 6.2 Interface architecture for single-PRA PHI

The following definitions are used in this subclause:

**Bundle:** A bundle denotes all Bd-channels of a PHI directed to a particular CRF-S.

**Sub-bundle:** A sub-bundle denotes all Bd-channels of a PHI except to a particular FH within the CRF-S.

NOTE: In case of a centralized FH a sub-bundle is identical to a bundle.

**Centralized FH Architecture:** A CRF-S has a centralized FH architecture, if the PH sees only one FH within this CRF-S.

**Decentralized FH Architecture:** A CRF-S has a decentralized FH architecture, if the PH sees more than one FH within the CRF-S.

#### 6.2.1 Local PHI access

Based on the functional model described in figure 2, figure 4 shows the interface architecture for a PHI consisting of a single PRA and having only local subscriber access (local PHI access, see clause 1).

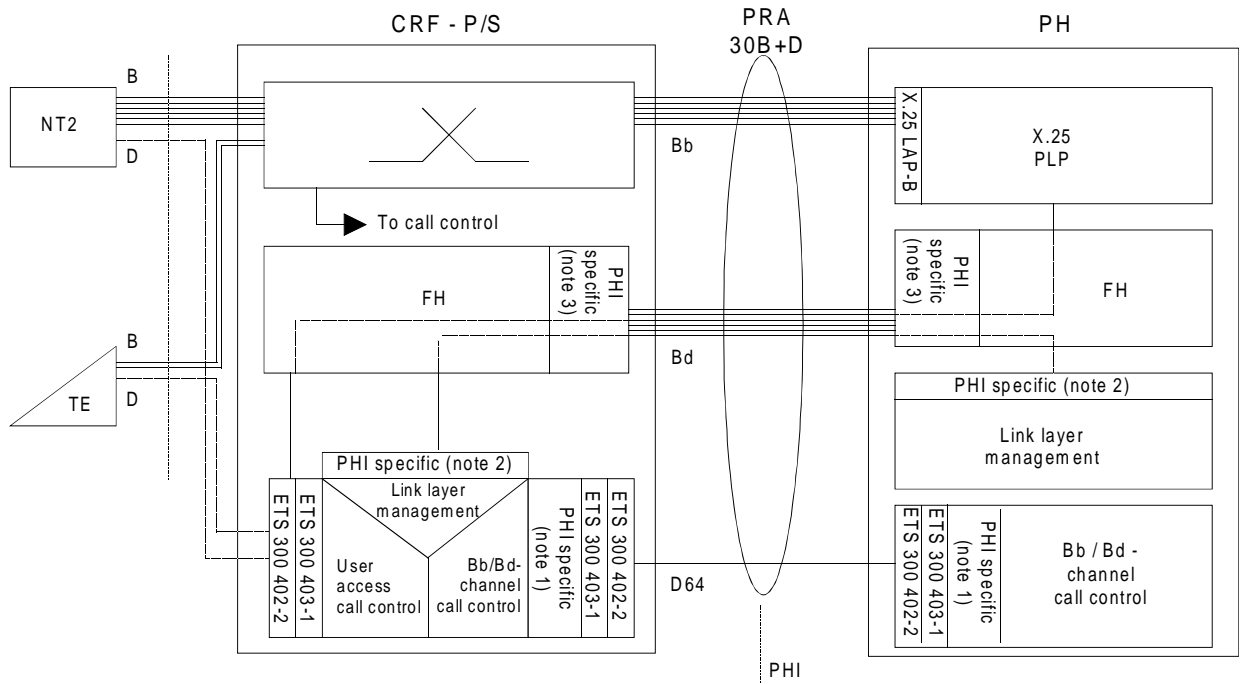
#### 6.2.2 Remote PHI access

A PHI (and even a single PRA) may serve one or more CRF-S accessing the PH via the CRF-P. This scenario is called remote PHI access (see clause 1). The functional model for this case is given in figure 3.

Bb and Bd-channels are established between a CRF-S and the PH, being connected through the CRF-P transparently.

Figure 5 describes the remote PHI access situation showing only the Bd-channels.

NOTE: As shown in the figure, bundles and sub-bundles may be distributed over more than one PRA of the PHI (e.g. for redundancy reasons), see subclause 7.2.

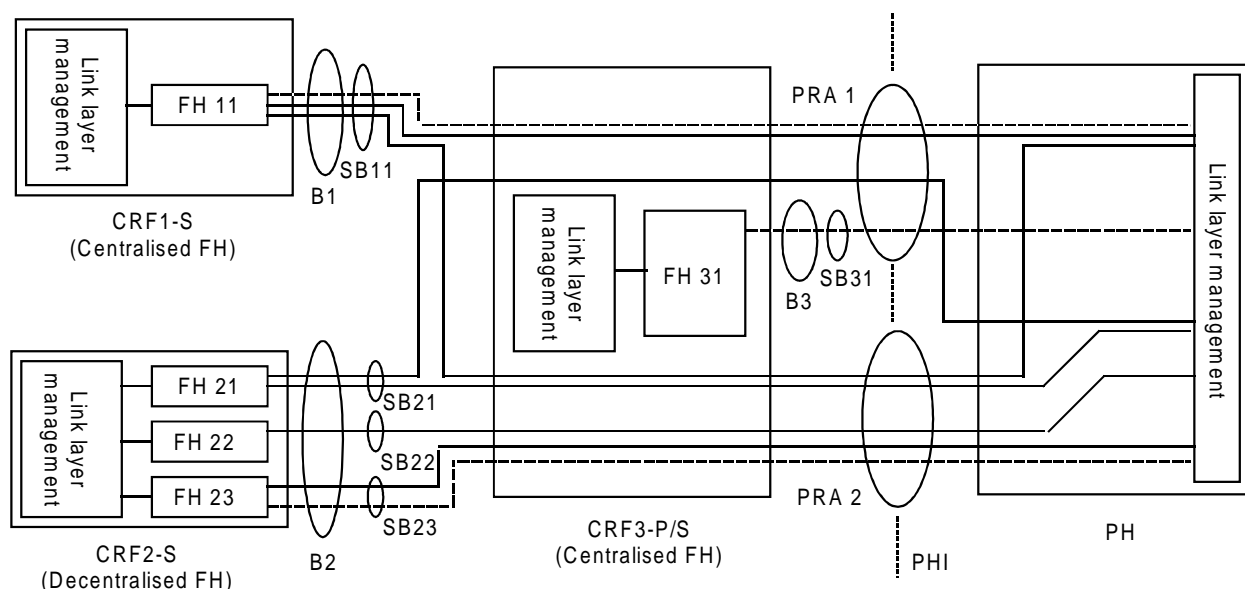


NOTE 1: PHI specific protocol as defined in subclauses 10.3, 10.4 and 11.3.2.

NOTE 2: PHI specific protocol used on the Bd-channels as defined in subclauses 10.5, 11.4 and 11.5.

NOTE 3: PHI specific protocol (Layer 2) used on the Bd-channels as defined in subclause 9.4.

**Figure 4: General interface architecture for PRA PHI**



**Explanation:**

- Bd-channel with active signalling link.
- Bd-channel without signalling link.
- B Bundle
- SB Subbundle

**Figure 5: Bd-channel architecture**  
**Example for local and remote access to the PHI and use of multiple PRAs**

**6.3 PHI channel types**

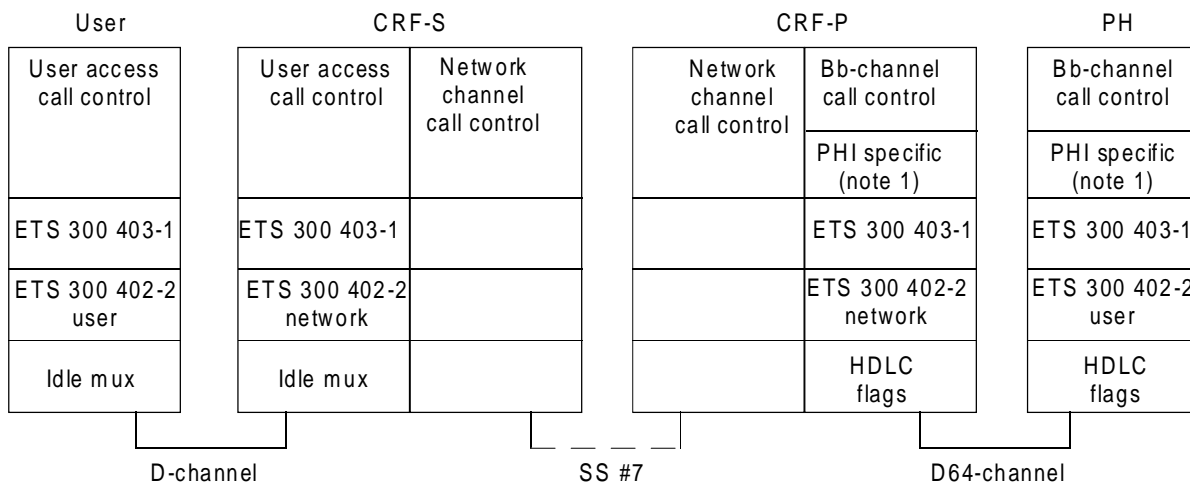
**6.3.1 D64-channel**

As in a regular PRA, the D64-channel is reserved for call control signalling for the B-channels (Bb and Bd-channels) of this PRA. The layer 2 protocol is a point-to-point data link according to ETS 300 402-2 [10], where the PH assumes the user side. The signalling information exchange on layer 3 is based on ETS 300 403-1 [11].

For the establishment and release of switched Bb-channels (case A) no modifications to ETS 300 403-1 [11] are required for the PHI, see subclause 10.2. For the establishment and release of switched Bb-channels (case B) signalling requirements are specified in subclause 10.3. The protocol stacks for the establishment and release of Bb-channels (case A and case B) are shown in figure 6.

For the establishment and release of switched or dynamically provisioned semi-permanent Bd-channels either packet mode or circuit mode procedures shall be used, see subclauses 10.4 and 11.3.2. Additional signalling information has to be exchanged between the PH and a CRF-S. This information is carried across the PHI in the ETS 300 403-1 [11] user-user information element. Details are defined in subclause 10.4. The protocol stacks for the establishment and release of Bd-channels are illustrated in figure 7.

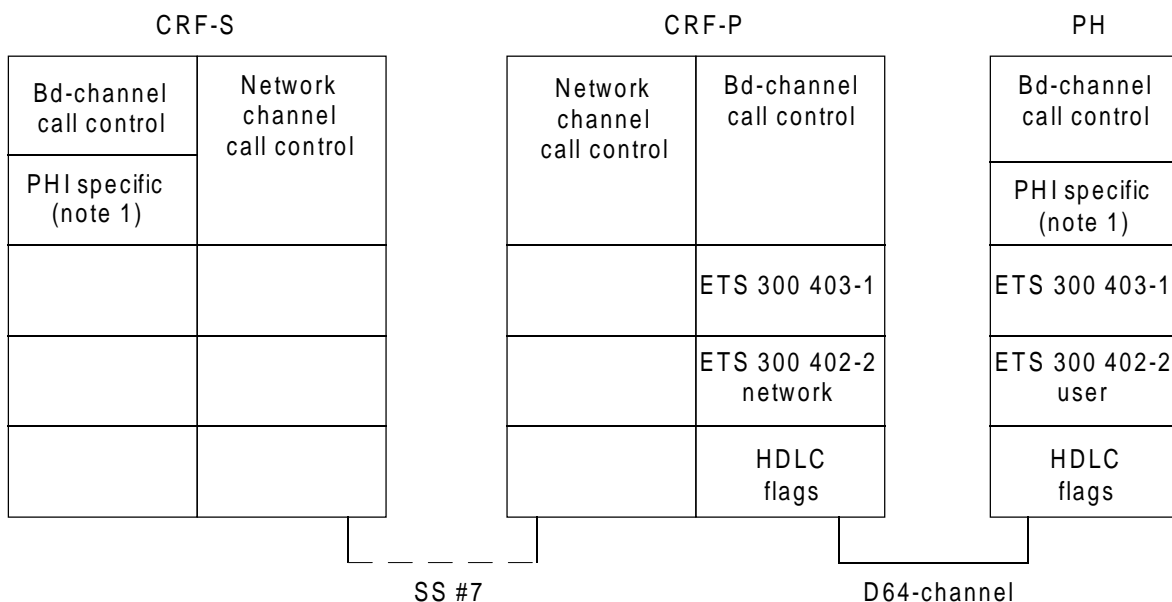




NOTE 1: Only applicable for case B, see clause 10.

NOTE 2: The indications in the boxes for layer 1 do not actually refer to the physical layer. They indicate how the transmission gap between frames is filled (either idle or flags) and whether there is a layer 2 multiplexing capability involved.

Figure 6: Protocol stacks for the establishment and release of Bb-channels



NOTE 1: PHI specific protocol as defined in subclauses 10.4 and 11.3.2.

NOTE 2: The indications in the boxes for layer 1 do not actually refer to the physical layer. They indicate how the transmission gap between frames is filled (either idle or flags) and whether there is a layer 2 multiplexing capability involved.

Figure 7: Protocol stacks for the establishment and release of Bd-channels

6.3.2 Bb-channels (case A and case B)

Bb-channels are used to support user B-channel packet mode services on the PHI. There exists a one-to-one correspondence between a subscriber B-channel used for packet mode services and a Bb-channel of the PHI. A transparent, switched connection between the B-channel of the subscriber's interface and the Bb-channel of the PHI is established through the CRFs involved. Both channels are allocated correspondingly either switched or for a period of time (semi-permanent), depending on the desired service. Procedures for provisioning of semi-permanent Bb-channels are described in subclauses 8.2.1.1 and 11.2.

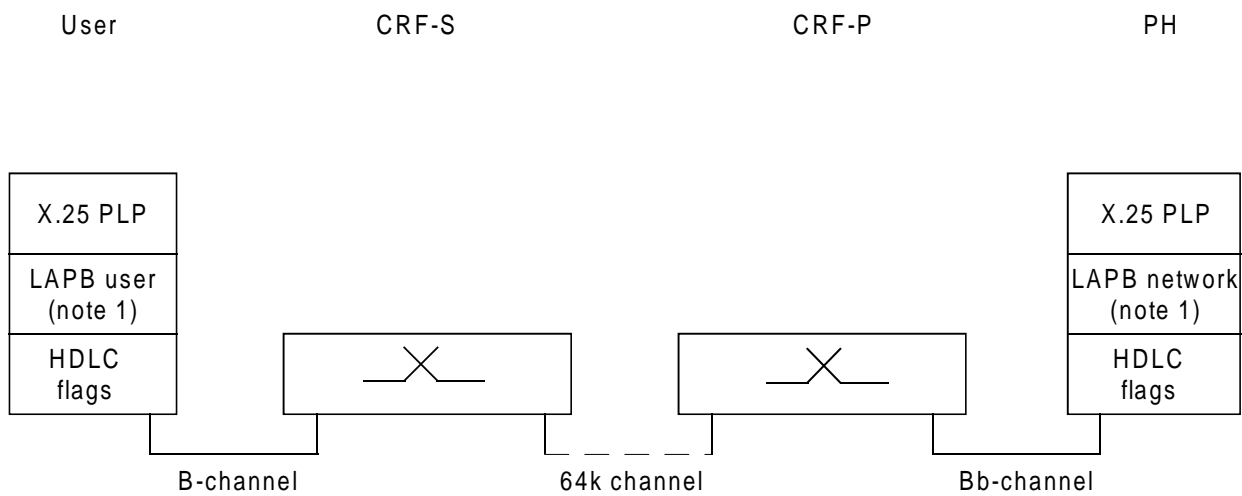
The protocol stacks for Bb-channels are given in figure 8.

### 6.3.3 Bd-channels

Bd-channels support user D-channel packet mode services on the PHI. They are used to transmit multiplexed subscriber D-channel packet data between a Frame Handler (FH) of a CRF-S and the PH. In addition, one Bd-channel per bundle carries the signalling connection for the link layer management of all Bd-channels of the bundle.

NOTE: The CRF-P is assumed to be transparent on layer 1 for the Bd-channels between the CRF-S and the PH. However, the use of an intermediate FH function in the CRF-P or elsewhere between CRF-S and CRF-P is also possible in case of semi-permanent links or PLLs (see figure 3).

Bd-channels are established on demand (switched) or for a period of time (semi-permanently). Procedures for the provisioning of semi-permanent Bd-channels are described in subclauses 8.2.1.2 and 11.3.



NOTE 1: In case A switched access, the layer 2 address allocation is done as defined in ITU-T Recommendation X.32 [3].

NOTE 2: The indications in the boxes for layer 1 do not actually refer to the physical layer. They indicate how the transmission gap between frames is filled (either idle or flags) and whether there is a layer 2 multiplexing capability involved.

**Figure 8: Protocol stacks for Bb-channels**

#### 6.3.3.1 Data transfer

Data packets from several subscriber D-channels and subscriber D-channel links (SAPI=16, see ETS 300 007 [20]) are statistically multiplexed onto a single Bd-channel. A layer 2 multiplexing function is thus needed both within the PH and the CRF-S. This function is called Frame Handler (FH), see figure 4. Either a Frame Switching (FS) or a Frame Relaying (FR) technique may be employed.

There exists a one-to-one correspondence between a SAPI=16 data link connection on the subscriber D-channel and a data link connection on the Bd-channel of the PHI.

The layer 2 protocol is based on ETS 300 402-2 [10] (LAPD). In order to allow for the multiplexing, however, an extended address field is used. The protocol is defined in clause 9.

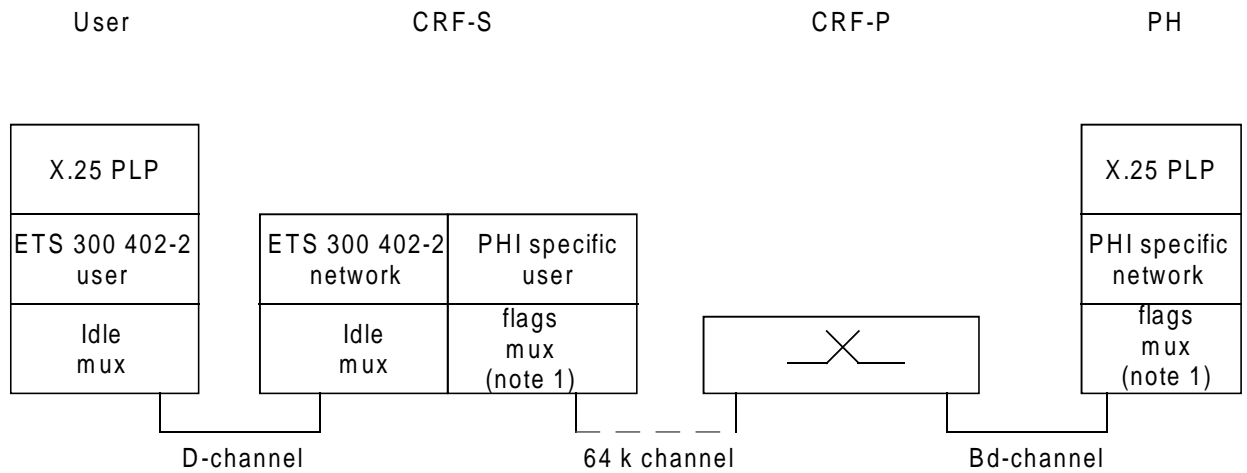
The protocol stacks for data transfer on a link established on a Bd-channel are described in figure 9. In this figure, a frame switching technique is assumed for the CRF-S.

### 6.3.3.2 Link layer management

The SAPI=16 packet data links on the subscriber D-channel and the layer 2 links on the Bd-channels of the PHI are established correspondingly either switched or for a period of time (PLL and semi-permanent access), according to the desired D-channel service.

For the switched access and dynamic provisioning of semi-permanent links or PLLs, link establishment and release on the PHI is controlled by a PHI specific signalling exchange between CRF-S and PH. This signalling exchange is carried out on a unique signalling connection within one particular Bd-channel (being determined by the PH) per bundle. It is defined in subclauses 10.5, 11.4, and 11.5. The responsibility for the selection of the particular Bd-channel and the establishment of the signalling link, as well as for the invocation of backup procedures (switchover) in case of failure, lies within the PH, see clause 9.

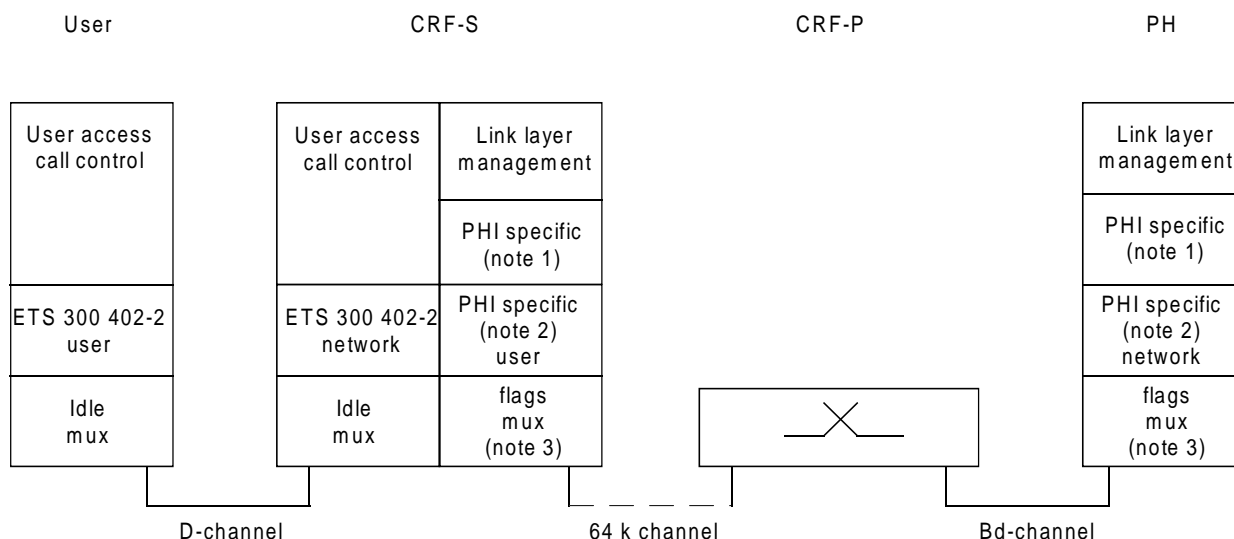
The protocol stacks for link establishment and release on Bd-channels are modeled in figure 10.



NOTE 1: For an interim period, "idle" may also be used.

NOTE 2: The indications in the boxes for layer 1 do not actually refer to the physical layer. They indicate how the transmission gap between frames is filled (either idle or flags) and whether there is a layer 2 multiplexing capability involved.

**Figure 9: Protocol stacks for data transfer on a link established in a Bd-channel**



NOTE 1: PHI specific protocol as defined in subclauses 10.5, 11.4 and 11.5.

NOTE 2: PHI specific protocol as defined in subclause 9.4.

NOTE 3: For an interim period, "idle" may also be used.

NOTE 4: The indications in the boxes for layer 1 do not actually refer to the physical layer. They indicate how the transmission gap between frames is filled (either idle or flags) and whether there is a layer 2 multiplexing capability involved.

**Figure 10: Protocol stacks for link establishment and release on the Bd-channel**

## 7 Interface configuration

### 7.1 Frame handler function at the CRF-S

Both Frame Switching (FS) and Frame Relaying (FR) techniques being employed in the CRF-S are supported by the PHI. The type of FH function does, however, have to be known to the PH.

### 7.2 Multi-PRA PHI configuration

The PHI may consist of one or more PRAs. Multi-PRA configurations may be required due to capacity and/or redundancy reasons, see figure 5.

In the case where both switched Bb and Bd-channels are supported, an additional functionality may be required in a multi-PRA PHI configuration. This additional requirement and a number of possible solutions are described in annex D.

## 8 Operations, Administration and Maintenance (OA&M)

### 8.1 General

#### 8.1.1 Scope

The PHI specification deals only with those PHI-related OA&M aspects, that require the coordination of CRF-P/S and PH. These aspects are called "PHI OA&M". OA&M requirements that are local to the CRF P/S side or the PH side of the PHI are not within the scope of this ETS.

The application of Open Systems Interconnection (OSI) network management protocols being defined by ISO and CCITT to PHI OA&M is a long term goal, but is beyond the scope of the current specification.

### 8.1.2 Definitions

Two types of PHI OA&M procedures (i.e. procedures for the OA&M coordination of CRF-P/S and PH) are distinguished:

- **Administrative Procedures:** These PHI OA&M procedures are separately activated on both sides of the interface. Synchronization is not automated, i.e. consistency has to be ensured externally. No signalling on the PHI is involved.
- **Dynamic Procedures:** These PHI OA&M procedures are activated by only one side of the PHI, and the activation is transferred to the other side by the means of PHI signalling. Consistency is thus ensured automatically.

Procedures for the establishment of semi-permanent channels and semi-permanent links or PLLs are called provisioning. Two types of provisioning procedures are distinguished:

**Static Provisioning:** Provisioning done by using administrative procedures.

**Dynamic Provisioning:** Provisioning done by using dynamic procedures.

### 8.1.3 Principles

PHI OA&M shall have the following general principles:

- **PHI OA&M requirements:** PHI OA&M requirements should be kept to a minimum, at least in the initial deployment phases of the PHI. Future evolution of these requirements should be viewed in the light of the development of OSI network management protocol standards being defined by ISO and CCITT.
- **Interdependencies of service data:** Static service data interdependencies between CRF P/S and PH, resulting from provisioning by administrative procedures, should be minimized. Service data provisioning by dynamic procedures (via signalling procedures defined in this specification) should be given preference.
- **Interdependencies of network related service information:** Static interdependencies of network related service information between the CRF-P/S side and the PH side (e.g. knowledge of configuration data of CRF-P/S and PH by PH and CRF-P/S respectively) should be minimized.
- **Accounting:** Accounting information should be collected either:
  - on the PH side of the PHI; or
  - on both sides of the PHI separately. In this case it is an administration's option whether to have separate billing for the circuit switched and the packet switched portion of the ISDN, or to merge the two bills off-line, e.g. on a subscriber number basis.

## 8.2 Layer 1 OA&M requirements

### 8.2.1 Administration

#### 8.2.1.1 Provisioning of semi-permanent Bb-channels

Only static provisioning of semi-permanent Bb-channels is supported by the PHI specification, see subclause 11.2.

In the case of statically provisioned semi-permanent Bb-channels, 64 kbit/s time slots in the 2 048 kbit/s PRA/PCM frame are preassigned in a fixed manner by bilateral agreement between CRF-P and PH.

### **8.2.1.2 Provisioning of semi-permanent Bd-channels**

Static and dynamic provisioning of semi-permanent Bd-channels is supported by the PHI specification, see subclause 11.3.

In the case of statically provisioned semi-permanent Bd-channels, 64 kbit/s time slots in the 2 048 kbit/s PRA/PCM frame are preassigned in a fixed manner by bilateral agreement between CRF-P and PH.

## **8.2.2 Operations and maintenance**

### **8.2.2.1 Primary rate access**

No PHI specific operations and maintenance requirements for PRAs between CRF-P and PH are defined. Operations and maintenance of layer 1 of the PHI PRAs is specified in ETS 300 011 [18] (subclauses 3.4 and 5.9 with the alteration that ET and TE correspond to CRF and PH respectively). Loopbacks are defined in annex D of ETS 300 011 [18].

### **8.2.2.2 Establishment and release of switched Bd-channels due to operational requirements**

The establishment of a switched Bd-channel may be triggered by a user request (first incoming or outgoing call) or by an operational action of CRF-S or PH (e.g. due to load considerations). The release of a switched Bd-channel is initiated by timer expiry (TPHI, see clause 10) or by an operational action of CRF-S or PH.

### **8.2.2.3 Re-establishment of dynamically provisioned semi-permanent Bd-channels in case of failure**

Automatic re-establishment in case of failure may be required.

## **8.3 Layer 2 OA&M requirements**

### **8.3.1 Bb-channels**

For B-channel services, both CRF-S and CRF-P are transparent on layer 2, see figure 8. ITU-T Recommendation X.25 [4] LAPB characteristics are only known to the PH. Thus, OA&M requirements are local to the PH and no PHI OA&M requirements exist.

### **8.3.2 Bd-channels**

For D-channel services, the CRF-S is not transparent on layer 2, see figure 9. Thus, OA&M coordination is required between CRF-S and PH.

#### **8.3.2.1 Administration**

The assignment of semi-permanent or PLL Bd-channel links on the PHI can be performed by using static provisioning or dynamic provisioning, see subclauses 11.4 and 11.5. Dynamic provisioning may be initiated by either CRF-S or PH.

The list of service data required at the CRF-S and the PH respectively and related to semi-permanent D-channel and PLL access methods, is given in subclause 5.1.3.

The maximum load on a Bd-channel shall be made available to both CRF-P/S and PH by administrative procedures.

### **8.3.2.2 Operations**

#### **8.3.2.2.1 General status and performance monitoring**

The PH shall monitor the following parameters:

- frame retransmission;
- frames transmitted/received per unit time;
- Bd-channel and processor utilization;
- frequency of busy conditions (on a per-link or per-channel basis).

#### **8.3.2.2.2 Load sharing**

Load sharing on Bd-channels shall be performed at link setup time by the PH and the CRF-S. The non-selecting side shall not reject the link activation because of Bd-channel load reasons.

The PH and the CRF-S shall use load criteria, which may be different. It is the responsibility of the service provider to align both criteria.

Examples of load criteria are:

- number of data links on the Bd-channel, e.g. data links on a Bd-channel may be established as long as a maximum number of data links is not exceeded;
- throughput on the Bd-channel, in both directions;
- utilization of the Bd-channel, in both directions;
- queue lengths of the Bd-channel;
- maximum number of ITU-T Recommendation X.25 [4] logical channels on the Bd-channel.

### **8.3.2.3 Maintenance**

The PH shall establish thresholds for the monitored performance parameters and shall take the following actions once the thresholds are exceeded, e.g. Bd-channel failure:

- indicate failure to layer 3, service interruption will occur;
- re-establish signalling link on another Bd-channel, if it was active on the failed Bd-channel; procedures are described in subclause 9.4;
- disconnect data links on the saturated Bd-channel;
- re-establish semi-permanent links on another Bd-channel;

NOTE: It is the user's responsibility to re-establish switched links and PLLs.

- disallow new links to be established on the failed or saturated Bd-channel;
- perform verification and restoration on the failed Bd-channel. Manual intervention is needed.

### **8.3.3 D64-channel**

Normal ETS 300 402-2 [10] procedures are used.

## 8.4 Layer 3 OA&M requirements

### 8.4.1 Service support

#### 8.4.1.1 ITU-T Recommendation X.25 Packet Layer Procedures (X.25PLP)

The layer 3 protocol during data transfer is X.25PLP for both B and D-channel services. Layer 3 characteristics are only known to the PH. Thus, OA&M requirements are local to the PH and no PHI OA&M requirements exist.

#### 8.4.1.2 PVCs on the D-channel

A PVC on the D-channel is defined on the PHI by the following parameters:

- DLCI;
- sub-bundle reference;
- CRF-S address.

**PVC maintenance:** In case of Bd-channel failure, the PVC is activated again when the failed link is re-established over another Bd-channel either by the user or the network.

### 8.4.2 Signalling (D64 and Bd-inband)

#### 8.4.2.1 Administration

The signalling mechanism defined for the PHI creates the following administrative PHI OA&M requirements:

In case of dynamic Bd-channel establishment, the following information needs to be provisioned at both sides of the PHI by administrative procedures:

- assignment of one address per CRF-S, see clause 10;
- assignment of one address per PH, see clause 10.

NOTE: In some solutions for multiple PRA, two addresses can be assigned per PH (see subclause 7.2).

#### 8.4.2.2 Operations

##### 8.4.2.2.1 D64-signalling

Operations requirements are specified in ETS 300 403-1 [11]. CRF-P and PH shall be able to detect failure of layer 3 on the D64-channel based on established thresholds of monitored parameters. Among these parameters are retransmission count and timers expiry.

PHI specific exception handling procedures are defined in subclauses 12.1 and 12.2.

##### 8.4.2.2.2 Bd-inband signalling

The PH shall continuously monitor the link (e.g. for unexpected messages, undefined messages, timer expiry) to ensure that layer 3 is working properly.

Exception handling procedures are defined in subclauses 9.4, 12.3, 12.4, and 12.5.



### 8.4.2.3 Maintenance

#### 8.4.2.3.1 D64-signalling

Upon detection of failure, existing switched connections shall be released and new calls shall be diverted to another PRA of the PHI, if available.

NOTE: Redundancy procedures are for further study.

#### 8.4.2.3.2 Bd-inband signalling

In case of failure, the PH shall initiate switchover of the signalling link to another Bd-channel, see subclause 9.4.

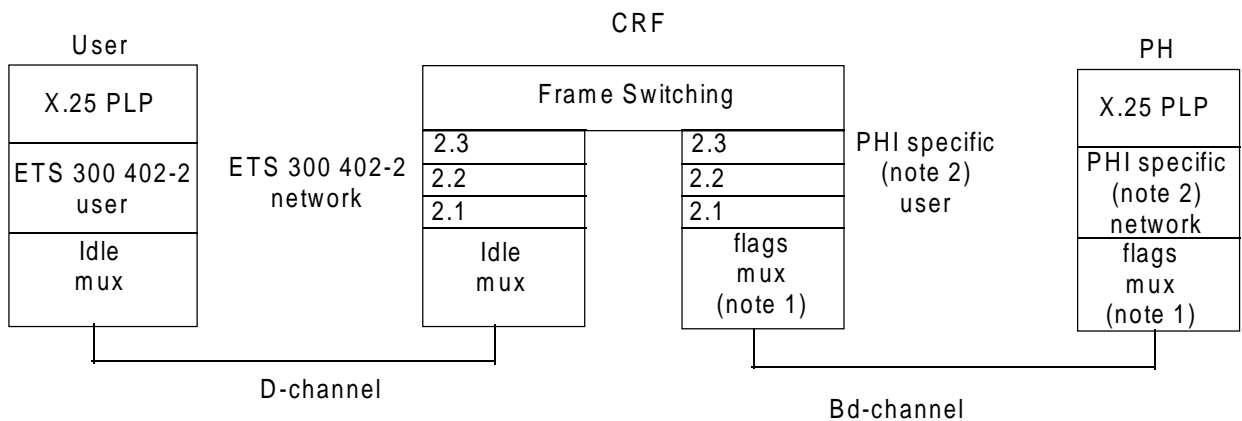
## 9 Frame multiplexing on the Bd-channels

### 9.1 Principle

The data links on the Bd-channels are designed according to ETS 300 402-2 [10]. However, as the application of the data link is different from ETS 300 402-2 [10], the address field is coded in a different way.

For each bundle, i.e. CRF-S/PH pair, the default layer 2 characteristics (window size, maximum frame length, timer values, etc.) are agreed for a period of time. All data links in the bundle adhere to these characteristics. The need to have individual data link layer characteristics for semi-permanent D-channel services and dynamic data link layer characteristics for switched D-channel services is for further study.

The FH implements a frame switching or frame relaying technique. With respect to the Command/Response bit, the PH assumes the network side, the FH the user side (see figures 11 and 12).



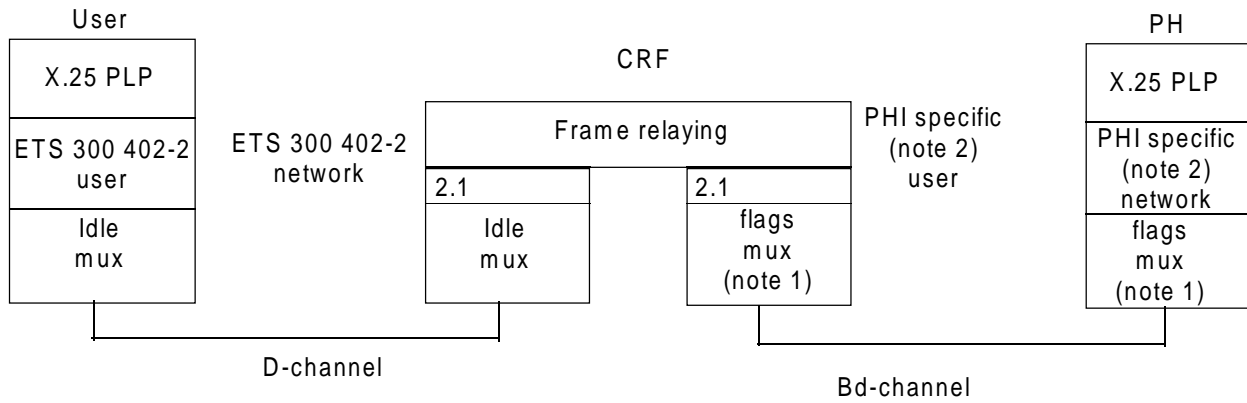
**Explanation:**

- 2.1: Core functions.
- 2.2: C/R-bit.
- 2.3: Unacknowledged and acknowledged procedures.

NOTE 1: The indications in the boxes for layer 1 do not actually refer to the physical layer. They indicate how the transmission gap between HDLC frames is filled (either idle or flags) and whether there is a layer 2 multiplexing capability involved.

NOTE 2: PHI specific protocol (layer 2) used on the Bd-channels as defined in subclause 9.4.

**Figure 11: Layered architecture for frame switching**



**Explanation:** 2.1: Core functions: Frame, FCS, Address.

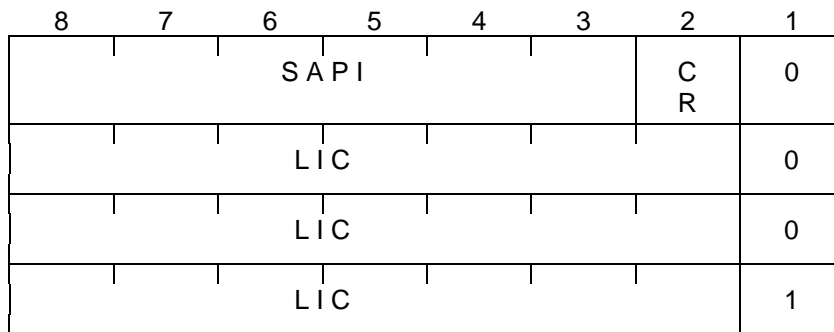
NOTE 1: The indications in the boxes for layer 1 do not actually refer to the physical layer. They indicate how the transmission gap between HDLC frames is filled (either idle or flags) and whether there is a layer 2 multiplexing capability involved.

NOTE 2: PHI specific protocol (layer 2) used on the Bd-channels as defined in subclause 9.4.

**Figure 12: Layered architecture for frame relaying**

**9.2 Address field layout**

A unique Data Link Connection Identifier (DLCI) shall be used on the Bd-channel (see figure 13). This data link connection identifier on the Bd-channels shall be agreed on between the PH and the CRF-S either by provisioning (for semi-permanent or PLL D-channel services) or by a signalling exchange prior to data link establishment (for switched D-channel services).



**Figure 13: DLCI structure**

All links on a Bd-channel have DLCIs of the same length. This DLCI is 4 octets long. The first octet contains a SAPI value, the C/R bit, and an address extension bit (the latter is coded as "0"). The following 3 octets contain a Link Identification Code (LIC); each octet also contains an address extension bit which is coded as "0" except in the last octet where it is set to "1".

The FH is responsible for the address mapping of the frames in the Bd-channel containing a DLCI in the address field and the frames in the subscriber's D-channel containing TEI and SAPI values.

The DLCI is unique within a sub-bundle.

NOTE: The DLCI is a bit pattern used solely to distinguish between different link connections on the Bd-channel; no internal structure is perceived. However, as the CRF-S assigns all DLCI values for switched D-channel services, the CRF-S may apply some internal rules how to construct the LIC, e.g., by retaining the TEI value of the data link on the user-network interface and complementing it with a bit pattern that indicates the particular user-network interface.

### 9.3 Subscriber data links

The SAPI value of subscriber data links is set to "16".

### 9.4 Signalling data link

In a centralized FH implementation, every Bd-channel can potentially carry the signalling data link; in a decentralized FH implementation, some Bd-channels may not be suitable to carry a signalling data link. The PH needs no OA&M data for the classification of Bd-channels into those "suitable" and "non suitable"; the distinction is made known to it by the CRF-S dynamically.

#### 9.4.1 The DLCI value of the signalling data link

The DLCI of this signalling link has the same length as the DLCIs of all other data links. It is coded as follows:

- SAPI The SAPI value is set to "0";
- LIC All bits of the LIC are set to "0".

#### 9.4.2 Establishment of the signalling data link

The PH is responsible for establishing and maintaining the signalling data link. The PH establishes the signalling data link in the first Bd-channel that is established between a CRF-S and the PH (irrespective of the direction of the establishment).

As this Bd-channel carries the signalling data link, it shall not be cleared before all other Bd-channels in the bundle have been cleared.

NOTE: If only PLL and semi-permanent D-channel services are offered and no dynamic provisioning is used, no signalling data link is required.

#### 9.4.3 Signalling data link failure

If the CRF-S implements a frame relaying technique, both the CRF-S and the PH shall implement a timer T309, see ETS 300 403-1 [11]. If the signalling data link disconnects (e.g., due to a failure situation), timer T309 is started.

If a signalling data link is established before expiry of T309, the timer is stopped and no further action is taken.

If T309 expires, all signalling data which belongs to a call reference is released.

If the CRF-S implements a frame relaying technique, this entails the automatic disconnection of all data links for switched D-channel services.

#### 9.4.4 Recovery of the signalling data link

Should the Bd-channel carrying the signalling data link fail, it is the responsibility of the PH to re-establish it. It proceeds as follows:

- a) if no further Bd-channel between the CRF-S and the PH exists, the PH takes no action;

NOTE 1: The re-establishment of a Bd-channel is instigated by the possible recovery action of the subscribers whose data links and, therefore, also the virtual circuits, got cleared and disconnected when the Bd-channel failed. Furthermore, for dynamically provisioned semi-permanent Bd-channels, a network internal mechanism may attempt the re-establishment of the Bd-channel.

- b) if another Bd-channel still exist in the bundle, the PH chooses one of the remaining Bd-channels and establishes a new signalling link in that Bd-channel. If the CRF-S rejects the establishment of the signalling data link, e.g. because it is not suitable to carry the signalling data link, the procedure b) is repeated, in this case, the PH should, if possible, select a Bd-channel in another sub-bundle;

NOTE 2: The PH may select the Bd-channel dependent on the traffic load it perceives on the remaining Bd-channels. Alternatively, it might have reserved some traffic capacity in a Bd-channel in anticipation of a possible data link failure.

- c) if none of the remaining Bd-channels of the bundle is capable of carrying the signalling data link, the PH takes no further action.

NOTE 3: With the first incoming ITU-T Recommendation X.25 call request for a switched D-channel service, the PH tries to establish a new Bd-channel; the CRF-S has to realise that a signalling data link needs to be established. This realization of the absence of a signalling data link is also required, if a subscriber starts link establishment for a switched D-channel service on the user-network interface.

### 9.5 Switchover and concentration

During the existence of a bundle, the situation may arise that the Bd-channel carrying the signalling data link does not carry any other data links but other Bd-channels exist in the bundle that contain one or more subscriber data links and enough capacity would be available to also carry the signalling data link. The switchover procedure which the PH may invoke and which is outlined in annex E is optional.

During the existence of a bundle, the situation may arise that several Bd-channels of a sub-bundle are only lightly loaded with traffic on subscriber data links. From a network resource preservation point of view, it might be advantageous to concentrate the data links to fewer Bd-channels within the same sub-bundle and, thus, release the emptied Bd-channels. The concentration of subscriber data links can be achieved together with the switchover procedure above. The procedure as outlined in annex E is optional.

### 9.6 Reset procedures

If due to a failure a Bd-channel, as seen from one side, is going to be released, this side (CRF-S or PH side) may indicate to the remote side to clear all its data links which were established on the Bd-channel.

This indication can be given to the remote side either:

- by a one-by-one disconnection of the data links. In this case the sending of a message and the receiving of its acknowledgement are needed for each data link; or
- by using a RESET procedure. In this case, only one exchange of messages is sufficient to clear all the data links.

The RESET procedure which requires the knowledge of all data links established on a Bd-channel is outlined in annex F.

### 9.7 Bd-channel continuity check

The Bd-continuity check procedures provide a means to monitor the state of one specific Bd-channel. This state shall be used during the Bd-channel selection process. They apply regardless of whether the FH implements a frame switching or frame relaying technique.

The Bd-continuity check procedures run as long as the Bd-channel is in one of the operational states. Entering and leaving the operational states is controlled and/or coupled with OA&M interventions and/or with (if dynamic establishment) signalling.

Two operational states of the Bd-channel are identified:

- in-service: the Bd-channel can be selected for new datalinks;
- out-service: the Bd-channel shall not be selected for new datalinks.

The both-way continuity check procedure (see subclause 9.7.2.1) is the default procedure. The CRF-S and the PH may agree to use instead the procedure based on HDLC flags (see subclause 9.7.1) or the one-way continuity check (see subclause 9.7.2.2).

### **9.7.1 HDLC flag continuity check procedure**

Both the FH and the PH shall use the HDLC flag sequence as interframe time fill. Also in the no-traffic situation, receipt of these flag sequence assures the continuity of the Bd-channel.

In all operational states the flag pattern is sent. The out-service state is the initial state after the establishment of the Bd-channel.

The Bd-channel in the out-service state enters the in-service state when a continuous serie of flag patterns (without interruption of any idle pattern) is received during time Tcf1.

The Bd-channel in the in-service state enters the out-service state when a continuous serie of idle patterns (without interruption of any flag pattern) is received during time Tcf2.

Parameter set:

- Tcf1 = 1000 msec;
- Tcf2 = 1000 msec.

### **9.7.2 Management frame continuity check procedure**

This procedure applies in both ways. For an interim period of time, a one-way procedure is allowed.

#### **9.7.2.1 Both-way procedure description**

Both the FH and the PH initiate and reply on this procedure. The procedure initiated by the FH and the one initiated by the PH run in parallel and independant of each other.

At the initiators side:

- when the Bd-channel becomes operational, the initiator transmits a check request frame and starts a timer T200;
- when T200 times out, the check request is retransmitted and T200 is restarted;
- when T200 is running and a valid check response is received, T200 is stopped and timer Tcc is started; when Tcc is running as a check response is received, no action is taken;

NOTE: At the initiator's side only either T200 or Tcc is running at a time. Under normal operation a CHECK-RESPONSE is not expected while Tcc is running. Exceptionally, receipt of a CHECK-RESPONSE may occur while Tcc is running, e.g. in the case that the sending of a CHECK-RESPONSE was delayed on the responding side and the initiator's side has re-transmitted the CHECK-REQUEST on expiry of T200.

- when Tcc times out, a check request is transmitted and timer T200 is started;
- the Bd-channel state, as seen by the initiator, changes from out-service into in-service when Ncc consecutive valid check responses have been received with interval Tcc;

- the Bd-channel state, as seen by the initiator, changes from in-service into out-service when no valid response was received at any of the N200 consecutive retransmissions of check request with interval T200.

At the replier's side:

- when receiving a check request frame, a check response frame is sent back, with the same LIC value as that of the check request.

Implementations of the FH which also cover the interim period of PH implementation will set the acknowledgement indication as described in 9.7.2.2 and are allowed to do so if the PH is also the initiator. In the latter case the PH will ignore the setting of the acknowledgement indication.

### 9.7.2.2 One-way procedure description

At the FHs side: the description of subclause 9.7.2.1 applies with the following additions:

- the FH keeps an acknowledgement variable. This variable can be set or cleared. The acknowledgement indication in the check request is set/cleared if this variable is set/cleared;
- when the Bd-channel becomes operational, the acknowledgement variable is cleared;
- when receiving a valid check response, the acknowledgement variable is set;
- after N200 consecutive timeouts of T200 because of retransmissions, the acknowledgement variable is cleared again;
- the FH may discard any check request received from the PH.

At the PHs side:

- when the Bd-channel becomes operational, the Bd-channel state is set to out-service and the PH waits for a check request;
- when receiving a check request frame, a check response frame is sent back with the same LIC value as that of the check request and if in the in-service start Tcc\* is restarted;
- the Bd-channel state, as seen by the PH, changes from out-service into in-service when a check request frame was received with the acknowledgement indication set;
- the Bd-channel state, as seen by the PH, changes from in-service into out-service when a check request frame was received with the acknowledgement indication cleared or when Tcc\* times out.

### 9.7.2.3 Management frame layouts

The DLCI value of these UI frames is constructed as follows:

- the SAPI value is set to "63";
- the LIC value can be set by the initiator to any value.

The information field of the UI frame contains the indication of the message type "**check request**" or "**check response**" and (for an interim period of time) the acknowledgement indication.

See tables 1 and 2.

**9.7.2.4 Parameter set**

T200 maximum round trip delay, parameter defined in subclause 9.10.

N200 maximum number of retransmissions, parameter defined in ETS 300 402-2 [10].

Ncc: number of consecutive **checks requests** needed before entering the in service state.

Default value: 3 (both-way procedure)

Value: 2 (one-way procedure)

Tcc: interval timer

Default value: 10 sec

Tcc\*: - Tcc + (N200 + 2) \* T200

**Table 1: Message structure for Bd-channel check**

8	7	6	5	4	3	2	1
Management entity identifier							
Message Type							

**Table 2: Message codes for Bd-channel check**

Message name	Management Entity ID	Message Type
Check request	0001 0000	AXXX 0001
Check response	0001 0000	XXXX 0010

- X reserved for further applications (default value: X = 0).
- A = 1: acknowledgement indicator set.
- A = 0: acknowledgement indicator cleared or acknowledgement indicator not used.

**9.8 Connection verification procedure**

The connection verification procedure of ETS 300 402-2 [10] applies.

**9.9 Peer busy procedures**

The peer busy procedures as specified in ETS 300 402-2 [10] apply. Nevertheless, the timer T200 is allocated a value which depends on the situation as follows:

- timer T200 is activated with "value 1" for protecting against frame corruption;
- timer T200 is activated with "value 2" when waiting for the next polling cycle in the peer busy condition.

NOTE 1: By allowing two distinct timer values, both peer busy polling and retransmission can be optimized in the Bd-channel environment.

The state table reflecting the use of two different timer values is given in annex G.

Implementations where the two values for timer T200 are equal shall be allowed; in this case, ETS 300 402-2 [10] is applied without modification.

NOTE 2: If the FH implements a frame relaying technique, the data link is established between the PH and the TE. Although the TE complying to ETS 300 402-2 [10] will not implement two different values for timer T200; the PH may still implement two different values for its timer T200.

### 9.10 Default timer values

The default timer values for the cases where the FH implements a frame switching or frame relaying technique are indicated in table 3.

NOTE: If the TE implements the default ETS 300 402-2 [10] value for timer T200 and the FH implements a frame relaying technique, the ETS 300 402-2 [10] protocol may not function properly if the round trip delay for a frame with the poll/final bit set to "1" (including queueing in the FH and the PH as well as the processing delay in the PH) can exceed the value of timer T200.

**Table 3: Default timer values**

	<b>frame switching</b>	<b>frame relaying</b>
T200 Value 1	1 s	2,5 s
Value 2	2 s	3 s
T203	60 s	60 s

### 9.11 Maintenance flow

Procedures and coding of the maintenance flow for Packet Mode Bearer Services provided on the D-channel are defined in annex K.

Maintenance flow is applicable for semipermanent and PLL access. Application of the maintenance flow for switched access is for further study.

Support of the maintenance flow is optional for both networks and subscriber equipment.

## 10 PHI signalling

### 10.1 General introduction

This clause lists only the requirements on the signalling messages and the information elements. Any specific coding is conforming to ETS 300 403-1 [11] or is detailed in clause 13 (coding of PHI specific information elements).

#### 10.1.1 Signalling procedures

The signalling for the establishment and release of B-channels for the switched B-channel services (case A and case B) as well as signalling for the establishment and release of dynamic Bd-channels is according to ETS 300 403-1 [11] or ETS 300 007 [20]; in the following subclauses, only deviations from those standards are described.

The signalling on the signalling data link in the Bd-channels, although utilising messages according to ETS 300 403-1 [11], represents a simplified version of the general ETS 300 403-1 [11] procedures. They are fully described in subclause 10.5.

#### 10.1.2 Signalling messages

The signalling messages used on the PHI are listed in the following subclauses.

#### 10.1.3 Information Elements

Only the mandatory information elements and the optional information elements used for the PHI purposes are listed in subclauses 10.2, 10.3 and 10.6. A message flowing on the D64-channel from the



CRF-P to the PH or vice versa may contain optional information elements specified in ETS 300 403-1 [11] (circuit mode) or ETS 300 007 [20] (packet mode) not mentioned in subclauses 10.2, 10.3 or 10.6. The PH ignores these information elements, it does not send these information elements.

In case of circuit-mode procedures, these information elements are treated in the CRF-P according to ETS 300 403-1 [11]. In case of packet mode procedures, these information elements are treated in the CRF-P according to ETS 300 007 [20].

The information elements transported in the signalling messages on the signalling link are completely described in subclause 10.5.

## 10.2 B-channel services, switched, case A

### 10.2.1 Signalling messages

The following table is derived from subclause 3.1 of ETS 300 403-1 [11].

**Table 4**

	Ref. to ETS 300 403-1 [11]	Restriction for PHI
Call establishment messages: ALERTING CALL PROCEEDING CONNECT CONNECT ACKNOWLEDGE PROGRESS SETUP SETUP ACKNOWLEDGE	3.1.1 3.1.2 3.1.4 3.1.5 3.1.10 3.1.16 3.1.17	a)    a)  N/A
Call information phase messages: RESUME RESUME ACKNOWLEDGE RESUME REJECT SUSPEND SUSPEND ACKNOWLEDGE SUSPEND REJECT USER INFORMATION	3.1.13 3.1.14 3.1.15 3.1.20 3.1.21 3.1.22 3.1.23	N/A N/A N/A N/A N/A N/A a)
Call clearing messages: DISCONNECT RELEASE RELEASE COMPLETE	3.1.6 3.1.11 3.1.12	
Miscellaneous messages: SEGMENT (CEPT Note) CONGESTION CONTROL FACILITY INFORMATION NOTIFY STATUS STATUS ENQUIRY	annex K 3.1.3 3.1.7 3.1.8 3.1.9 3.1.18 3.1.19	N/A N/A N/A N/A a)  

The CRF-P processes the messages indicated in the table and their information elements according to ETS 300 403-1 [11]. The PH also processes the message indicated in the table according to ETS 300 403-1 [11], unless an exception is specified below.

N/A: This message is not supported on the PHI; if any of these messages is received by the PH, it will be treated like an unknown message (see subclause 5.8 of ETS 300 403-1 [11]).

a) The PH does not generate this message. If the PH receives this message, it shall ignore it.

NOTE 1: The notes in the following tables describe details of the type (mandatory or optional) of the various information elements. If in the tables a reference to a note is followed by an asterisk (\*), the note is copied from ETS 300 403-1 [11] with an adaption of the terms "user" and "network" to "PH" and "CRF-P" only.

NOTE 2: The term "user" refers to the PH, the term "network" to the CRF-P.

### 10.2.1.1 Call proceeding

This table is derived from subclause 3.1.2 of ETS 300 403-1 [11].

**Table 5**

Information element	Ref	Direction	Type	Length	PHI
Protocol discriminator	4.2	both	M	1	
Call reference	4.3	both	M	2-3	
Message type	4.4	both	M	1	
Channel identification	4.5	both	O	2-*	a)

a) The "channel identification" information element is mandatory in the PH to CRF-P direction if this message is the first message in response to a SETUP message, unless the PH accepts the channel indicated in the SETUP message. It is optional in the CRF-P to PH direction.

### 10.2.1.2 Connect

This table is derived from subclause 3.1.4 of ETS 300 403-1 [11].

**Table 6**

Information element	Ref	Direction	Type	Length	PHI
Protocol discriminator	4.2	both	M	1	
Call reference	4.3	both	M	2-3	
Message type	4.4	both	M	1	
Channel identification	4.5	both	O	2-*	a)

a) The "channel identification" information element is mandatory in the PH to CRF-P direction if this message is the first message in response to a SETUP message, unless the PH accepts the channel indicated in the SETUP message. It is optional in the CRF-P to PH direction.

### 10.2.1.3 Connect acknowledge

This table is derived from subclause 3.1.5 of ETS 300 403-1 [11].

**Table 7**

Information element	Ref	Direction	Type	Length	PHI
Protocol discriminator	4.2	both	M	1	
Call reference	4.3	both	M	2-3	
Message type	4.4	both	M	1	

### 10.2.1.4 Disconnect

This table is derived from subclause 3.1.6 of ETS 300 403-1 [11].

**Table 8**

Information element	Ref	Direction	Type	Length	PHI
Protocol discriminator	4.2	both	M	1	
Call reference	4.3	both	M	2-3	
Message type	4.4	both	M	1	
Cause	4.5	both	M	4-32	

**10.2.1.5 Release**

This table is derived from subclause 3.1.11 of ETS 300 403-1 [11].

**Table 9**

Information element	Ref	Direction	Type	Length	PHI
Protocol discriminator	4.2	both	M	1	
Call reference	4.3	both	M	2-3	
Message type	4.4	both	M	1	
Cause	4.5	both	O	2-32	a)*

a)\* Mandatory in the first call clearing message, including when the RELEASE message is sent as a result of an error handling condition.

**10.2.1.6 Release complete**

This table is derived from subclause 3.1.12 of ETS 300 403-1 [11].

**Table 10**

Information element	Ref	Direction	Type	Length	PHI
Protocol discriminator	4.2	both	M	1	
Call reference	4.3	both	M	2-3	
Message type	4.4	both	M	1	
Cause	4.5	both	O	2-32	a)*

a)\* Mandatory in the first call clearing message, including when the RELEASE COMPLETE message is sent as a result of an error handling condition.

**10.2.1.7 Setup**

This table is derived from subclause 3.1.16 of ETS 300 403-1 [11].

**Table 11**

Information element	Ref	Direction	Type	Length	PHI
Protocol discriminator	4.2	both	M	1	
Call reference	4.3	both	M	2-3	
Message type	4.4	both	M	1	
Bearer capability	4.5	both	M	4-13	
Channel identification	4.5	both	O	2-*	a)
Calling party number	4.5	both	O	2-24	b)*
Called party number	4.5	both	O	2-23	c)
Low layer compatibility	4.5	both	O	2-16	d)

a) The "channel identification" element is mandatory in the PH to CRF-P direction. It may be included in the CRF-P to PH direction if the CRF-P wants to indicate a channel; if it is not included, its absence is interpreted as "any channel acceptable".

b)\* The "calling party number" information element may be included by the CRF-P to identify the calling user. It may be included in the PH to CRF-P direction to identify the PH.

- c) The "called party number" information element is mandatory in the PH to CRF-P direction. It is included by the CRF-P when called party number information is conveyed to the PH.
- d) The "low layer compatibility" information element is mandatory in the PH to CRF-P direction. It may be present in the CRF-P to PH direction, however, the PH ignores this information element.

#### 10.2.1.8 Status

This table is derived from subclause 3.1.18 of ETS 300 403-1 [11].

**Table 12**

Information element	Ref	Direction	Type	Length	PHI
Protocol discriminator	4.2	both	M	1	
Call reference	4.3	both	M	2-3	
Message type	4.4	both	M	1	
Cause	4.5	both	M	4-32	
Call state	4.5	both	M	3	

#### 10.2.1.9 Status enquiry

This table is derived from subclause 3.1.19 of ETS 300 403-1 [11].

**Table 13**

Information element	Ref	Direction	Type	Length	PHI
Protocol discriminator	4.2	both	M	1	
Call reference	4.3	both	M	2-3	
Message type	4.4	both	M	1	

#### 10.2.2 Case A, procedures for an outgoing call (CRF-P to PH)

(See figure B.1)

The call establishment across the PHI is according to subclause 5.2 of ETS 300 403-1 [11] using the messages specified in subclause 10.2.1 with the following restrictions:

- in the SETUP message, the bearer capability information element is coded as specified in clause H.1;
- without further agreement between the CRF-P and the PH, the "calling party number" information element in the SETUP message shall be coded as a national number;
- in case of calls from GSM PLMNs (see ETS 300 603 [21]) the "calling party number" may be an international number. The PH will only accept calls from GSM PLMNs when an agreement exists between the PH operator and the GSM PLMN operator;
- the PH ignores the "calling party subaddress" information element, if it is present in the SETUP message;
- without any further agreement between the CRF-P and the PH, the "called party number" information element in the SETUP message shall be coded as a national number;
- the PH ignores the "called party subaddress" information element, if it is present in the SETUP message;
- the procedures for B-channel selection (destination) as specified in subclause 5.2.3.1 apply with the following restriction: The indication "channel is indicated, no acceptable alternative" is not allowed;
- the procedures for the broadcast data link do not apply;
- the procedures for overlap receiving specified in subclause 5.2.4 do not apply.

the procedures for call confirmation as specified in subclause 5.2.5 apply with the following restriction: the PH never sends an ALERT message;

- the procedures for notification of interworking at the terminating interface specified in subclause 5.2.6 do not apply.

NOTE: The term "user" or "called user" refers to the PH, the term "network" to the CRF-P, the term "calling user" to the calling subscriber.

Subsequent layer 2 and layer 3 connection establishment initiated by the calling ITU-T Recommendation X.25 Data Terminal Equipment (DTE) is according to ITU-T Recommendation X.25 [4]. The layer 2 address assignment is specified in subclause 5.1.1.

The "calling party number" information element may be used by the PH for charging purposes. Optionally, a PH may also support a case A service without the identification of the calling party; however, it is then the responsibility of the PH to assure that only non-charged or reverse charged services may be used.

On the other hand, the PH inserts into the "calling address" of an outgoing ITU-T Recommendation X.25 [4] "call request" packet the address of the B-channel port.

The CRF-P shall support the calling line identification presentation supplementary service

### **10.2.3 Case A, procedures for an incoming call (PH to CRF-P)**

(See figure B.2)

Upon receipt of a "call request", the ensuing call establishment across the PH is according to subclause 5.1 of ETS 300 403-1 [11] using the messages specified in subclause 10.2.1 with the following restrictions:

- in the SETUP message, the "bearer capability" and "low layer compatibility" information elements are coded as specified in clauses H.1 and H.2;
- without any further agreement between the CRF-P and the PH, the "called party number" information element in the SETUP message shall be coded as a national number;
- without any further agreement between the CRF-P and the PH, the "calling party number" information element in the SETUP message shall be coded as a national number;
- the procedures for B-channel selection (originating) as specified in subclause 5.1.2 apply with the following restriction: Only the indication "channel is indicated, no acceptable alternative" is allowed;
- the procedures for overlap sending specified in subclause 5.1.3 do not apply;
- the procedures for call proceeding, overlap sending specified in subclause 5.1.2.5 do not apply;
- the procedures for call rejection specified in subclause 5.1.9 of ETS 300 403-1 [11] apply with the following addition: The PH clears the incoming virtual call towards the calling ITU-T Recommendation X.25 [4] DTE using an appropriate cause value from table 6 of ETS 300 007 [20];
- the procedures for notification of interworking specified in subclause 5.1.6 do not apply;
- the procedures for transit network selection specified in subclause 5.1.10 do not apply.

NOTE: The term "user" or "calling user" refers to the PH, the term "network" to the CRF-P, the term "called user" to the called subscriber.

Subsequent layer 2 and layer 3 connection establishment initiated by the PH is according to ITU-T Recommendation X.25 [4]. The layer 2 address assignment is specified in subclause 5.1.1.

**10.2.4 Case A, procedures for call clearing**

(See figures B.3, B.4 and B.5)

The procedures specified in subclause 5.3 of ETS 300 403-1 [11] using the messages specified in subclause 10.2.1 apply with the following exceptions:

- timer T320 is enabled for all switched B-channel accesses, i.e., Bb-channels;
- the exception condition (f) specified in subclause 5.3.2 of ETS 300 403-1 [11] does not apply;
- the procedures for clearing with tones and announcements provided in subclause 5.3.4.1 of ETS 300 403-1 [11], do not apply.

NOTE: The term "user" refers to the PH, the term "network" to the CRF-P.

If the B-channel access connection is cleared using ETS 300 403-1 [11] clearing messages while ITU-T Recommendation X.25 [4] virtual circuits still exist on the B-channel, the PH shall clear the switched virtual circuits with cause "17" (remote procedure error) and diagnostic "64" (call setup, call clearing, or registration problem). Similarly, on all permanent virtual circuits, the PH shall reset the virtual circuit with cause "17" (remote procedure error) and diagnostic "64" (call setup, call clearing, or registration problem).

If the timer T320 expires, the PH shall initiate the clearing of the B-channel access connection with cause "102" (recovery on timer expiry) and diagnostic "0" (no additional information).

**10.3 B-channel services, switched, case B**

**10.3.1 Signalling messages**

The following table is derived from annex B of ETS 300 007 [20].

**Table 14**

	<b>Ref. to ETS 300 007</b>	<b>Restriction for PHI</b>
Access connection establishment messages: ALERTING CALL PROCEEDING CONNECT CONNECT ACKNOWLEDGE PROGRESS SETUP	B.1 B.2 B.3 B.4 B.6 B.9	a)    Note below
Access connection clearing messages: DISCONNECT RELEASE RELEASE COMPLETE	B.5 B.7 B.8	
Miscellaneous messages STATUS STATUS ENQUIRY	B.10 B.11	

a) The PH ignores this message; it does not send this message.

The CRF-P processes the messages indicated in the table and their information elements according to ETS 300 007 [20]. The PH also processes the message indicated in the table according to ETS 300 007 [20], unless an exception is specified below.

The notes in the following tables describe details of the type (mandatory or optional) of the various information elements. If in the tables the reference to the note is followed by an asterisk (\*), the note is

copied from ETS 300 007 [20] with an adaption of the terms "user" and "network" to "PH" and CRF-P" only.

NOTE: The term "user" refers to the PH, the term "network" to the CRF-P.

### 10.3.1.1 Call proceeding

This table is derived from clause B.2 of ETS 300 007 [20].

**Table 15**

Information element	Ref	Direction	Type	Length	PHI
Protocol discriminator	4.2	both	M	1	
Call reference	4.3	both	M	2-3	
Message type	4.4	both	M	1	
Channel identification	4.5	both	O	2-5	a)

- a) The "channel identification" information element is mandatory in the PH to CRF-P direction if this message is the first message in response to a SETUP message, unless the PH accepts the channel indicated in the SETUP message. It is optional in the CRF-P to PH direction.

### 10.3.1.2 Connect

This table is derived from clause B.3 of ETS 300 007 [20].

**Table 16**

Information element	Ref	Direction	Type	Length	PHI
Protocol discriminator	4.2	both	M	1	
Call reference	4.3	both	M	2-3	
Message type	4.4	both	M	1	
Channel identification	4.5	both	O	2-5	a)

- a) The "channel identification" information element is mandatory in the PH to CRF-P direction if this message is the first message in response to a SETUP message, unless the PH accepts the channel indicated in the SETUP message. It is optional in the CRF-P to PH direction.

### 10.3.1.3 Connect acknowledge

This table is derived from clause B.4 of ETS 300 007 [20].

**Table 17**

Information element	Ref	Direction	Type	Length	PHI
Protocol discriminator	4.2	both	M	1	
Call reference	4.3	both	M	2-3	
Message type	4.4	both	M	1	

### 10.3.1.4 Disconnect

This table is derived from clause B.5 of ETS 300 007 [20].

**Table 18**

Information element	Ref	Direction	Type	Length	PHI
Protocol discriminator	4.2	both	M	1	
Call reference	4.3	both	M	2-3	
Message type	4.4	both	M	1	
Cause	4.5	both	M	4-32	

**10.3.1.5 Release**

This table is derived from clause B.7 of ETS 300 007 [20].

NOTE: Call awarding on an existing channel is not supported on the PHI.

**Table 19**

Information element	Ref	Direction	Type	Length	PHI
Protocol discriminator	4.2	both	M	1	
Call reference	4.3	both	M	2-3	
Message type	4.4	both	M	1	
Cause	4.5	both	O	2-32	a)*

a)\* Mandatory in the first call clearing message, including when the RELEASE message is sent as a result of an error handling condition.

**10.3.1.6 Release complete**

This table is derived from clause B.8 of ETS 300 007 [20].

**Table 20**

Information element	Ref	Direction	Type	Length	PHI
Protocol discriminator	4.2	both	M	1	
Call reference	4.3	both	M	2-3	
Message type	4.4	both	M	1	
Cause	4.5	both	O	2-32	a)*

a)\* Mandatory in the first call clearing message, including when the RELEASE COMPLETE message is sent as a result of an error handling condition.

**10.3.1.7 Setup**

This table is derived from clause B.9 of ETS 300 007 [20].

**Table 21**

Information element	Ref	Direction	Type	Length	PHI
Protocol discriminator	4.2	both	M	1	
Call reference	4.3	both	M	2-3	
Message type	4.4	both	M	1	
Bearer capability	4.5	both	M	7	a)*
Channel identification	4.5	both	O	2-5	b)
Calling party number	4.5	both	O	2-23	c)
Calling party subaddress	4.5	both	O	2-23	d)
Called party number	4.5	both	O	2-24	e)
Called party subaddress	4.5	u>n	O	2-23	f)

a)\* Used to identify the ISDN packet mode bearer capability.

b) The "channel identification" information element is mandatory in the PH to CRF-P direction. It may be included in the CRF-P to PH direction if the CRF-P wants to indicate a channel; if it is not included, its absence is interpreted as "any channel acceptable".

c) The "calling party number" information element is mandatory in the CRF-P to PH direction. The "calling party number" information element may be included in the PH to CRF-P direction if the PH implements ITU-T Recommendation X.25 [4] to information element mapping and provides indication to the called TE of the "calling party number".



- d) The "calling party subaddress" information element may be included in the PH to CRF-P direction if the PH implements ITU-T Recommendation X.25 [4] to information element mapping and provides indication to the called TE of the "calling party subaddress".
- e) The "called party number" information element is mandatory in the PH to CRF-P direction. It is included by the CRF-P when called party information is conveyed to the PH.
- f) The "called party subaddress" information element may be included in the PH to CRF-P direction if the PH implements ITU-T Recommendation X.25 [4] to information element mapping and provides indication to the called TE of the "called party subaddress".

#### 10.3.1.8 Status

This table is derived from clause B.10 of ETS 300 007 [20].

**Table 22**

Information element	Ref	Direction	Type	Length	PHI
Protocol discriminator	4.2	both	M	1	
Call reference	4.3	both	M	2-3	
Message type	4.4	both	M	1	
Cause	4.5	both	M	4-32	
Call state	4.5	both	M	3	

#### 10.3.1.9 Status enquiry

This table is derived from clause B.11 of ETS 300 007 [20].

**Table 23**

Information element	Ref	Direction	Type	Length	PHI
Protocol discriminator	4.2	both	M	1	
Call reference	4.3	both	M	2-3	
Message type	4.4	both	M	1	

#### 10.3.2 Case B, procedures for an outgoing call (CRF-P to PH)

(See figures B.6 and B.7)

The call establishment across the PHI is according to subclause 5.2 of ETS 300 403-1 [11] using the messages specified in subclause 10.3.1 with the following restrictions:

- in the SETUP message, the "bearer capability" information element is coded as specified in clause H.3;
- without further agreement between the CRF-P and the PH, the "calling party number" information element in the SETUP message shall be coded as a national number;
- in case of calls from GSM PLMNs (see ETS 300 603 [21]) the "calling party number" may be an international number. The PH will only accept calls from GSM PLMNs when an agreement exists between the PH operator and the GSM PLMN operator;
- if the "calling party subaddress" information element is present in the SETUP message, the PH may ignore this information; alternatively, the PH may use this information for profile selection;
- the PH ignores the "called party number" information element, if it is present in the SETUP message;
- the PH ignores the "called party subaddress" information element, if it is present in the SETUP message;

- the procedures for B-channel selection (destination) as specified in subclause 5.2.3.1 of ETS 300 403-1 [11] apply with the following restriction: The indication "channel is indicated, no acceptable alternative" is not allowed;
- the procedures for the broadcast data link do not apply;
- the procedures for overlap receiving specified in subclause 5.2.4 of ETS 300 403-1 [11] do not apply;
- the procedures for call confirmation as specified in subclause 5.2.5 apply with the following restriction: the PH never sends an ALERT message;
- the procedures for notification of interworking at the terminating interface specified in subclause 5.2.6 do not apply.

NOTE 1: The term "user" or "called user" refers to the PH, the term "network" to the CRF P, the term "calling user" to the calling subscriber.

Subsequent layer 2 and layer 3 connection establishment initiated by the PH is according to ITU-T Recommendation X.25 [4]. The PH assumes the role of the DCE.

The network provided or verified "calling party number" is required by the PH for charging purposes and possible profile selection. Whenever the SETUP message does not contain a "verified" or "network provided" "calling party number", the PH will reject the outgoing call. If the outgoing ITU-T Recommendation X.25 "call request" packet includes a "calling address" which does not match the "calling party number", the PH shall either clear the call with an appropriate cause value or replace the "calling address" by one derived from the verified or network provided "calling party number". This will be the address of the B-channel port if the "calling party number" is a number from a foreign GSM PLMN.

If the "calling address" is not included, the PH inserts the "calling party number" in the "calling address" of the outgoing ITU-T Recommendation X.25 "call request" packet.

The CRF-P shall support the calling line identification presentation supplementary service.

NOTE 2: The CLIR supplementary service (see ETS 300 093 ) is not supported for packet mode call setups.

### 10.3.3 Case B, procedures for an incoming call (PH to CRF-P)

(See figures B.8 and B.9)

If a Bb-channel establishment is required upon receipt of an incoming ITU-T Recommendation X.25 [4] "call request", the establishment procedures across the PHI is according to subclause 5.1 of ETS 300 403-1 [11] using the messages specified in subclause 10.3.1 with the following restrictions:

- in the SETUP message, the "bearer capability" information element is coded as specified in clause H.3;
- the content of the "called party number" information element is derived from the "called address" of the incoming ITU-T Recommendation X.25 [4] "call request";
- if the PH implements ITU-T Recommendation X.25 [4] to information element mapping and provides indication to the called TE of the "called party subaddress" in the SETUP message; the content of this information element is derived from the "called address extension" of the incoming ITU-T Recommendation X.25 [4] "call request";
- if the PH implements ITU-T Recommendation X.25 [4] to information element mapping and provides indication to the called TE of the "calling party number" in the SETUP message; the content of this information element is derived from the "calling address" of the incoming ITU-T Recommendation X.25 [4] "call request". Without any further agreement between the CRF-P and

the PH, the calling party number shall be coded as a national number. In addition, the numbering plan, i.e, CCITT Recommendations E.164 [13] or X.121 [5], shall be indicated;

- the CRF-P shall accept the "calling party number" provided by the PH. The PH shall indicate a "network provided" screening and the presentation indicator shall be set to "presentation allowed". The CRF-P shall not replace it with the address of the PH;
- if the PH implements ITU-T Recommendation X.25 [4] to information element mapping and provides indication to the called TE of the "calling party subaddress" in the SETUP message; the content of this information element is derived from the "calling address extension" of the incoming ITU-T Recommendation X.25 [4] "call request";
- the procedures for B-channel selection (originating) as specified in subclause 5.1.2 apply with the following restriction: Only the indication "channel is indicated, no acceptable alternative" is allowed;
- the procedures for overlap sending specified in ETS 300 403-1 [11] subclause 5.1.3 do not apply;
- the procedures for call proceeding, overlap sending specified in ETS 300 403-1 [11] subclause 5.1.5.2 do not apply;
- the procedures for call confirmation specified in ETS 300 403-1 [11], subclause 5.1.7 do not apply;
- the procedures for call rejection specified in subclause 5.1.9 of ETS 300 403-1 [11] apply with the following addition: The PH clears the incoming virtual call toward the calling ITU-T Recommendation X.25 [4] DTE using an appropriate cause value from table 6 of ETS 300 007 [20];
- the procedures for notification of interworking at the originating interface specified in ETS 300 403-1 [11] subclause 5.1.6 do not apply;
- the procedures for transit network selection specified in ETS 300 403-1 [11], subclause 5.1.10 do not apply.

NOTE: The term user or "calling user" refers to the PH, the term "network" to the CRF-P, the term "called user" to the called subscriber.

Subsequent layer 2 and layer 3 connection establishment initiated by the PH is according to ITU-T Recommendation X.25 [4]; the PH assumes the role of the DCE.

If the "calling party number" is not present, the presentation of the address of the PH to the subscriber shall be avoided using the "calling line identification restriction" supplementary service.

#### **10.3.4 Case B, procedures for call clearing**

(See figures B.3, B.4 and B.5)

The procedures specified in subclause 5.3 of ETS 300 403-1 [11] using the messages specified in subclause 10.3.1 together with the exceptions detailed in subclause 10.2.4 apply.

#### **10.4 Dynamically provisioned semi-permanent and switched Bd-channels**

Networks employ packet mode procedures (see subclause 10.3) for the establishment of Bd-channels.

Networks not implementing the ETS 300 007 [20] case B procedures for B-channels may use circuit mode procedures (see subclause 10.2).

Networks evolving from circuit mode procedures only to case B implementations or those using Bd-channels for general purpose services may stay with the circuit mode procedures for the establishment of Bd-channels.

The PH needs to identify the CRF-S; therefore, a network internal address is required which may take the form of an CCITT Recommendation E.164 [13] number. In addition, also the CRF-S needs to identify the

PH access; hence, this access also needs a network internal address which may take the form of an CCITT Recommendation E.164 [13] number.

NOTE 1: This in itself is not necessarily part of the national numbering plan.

To support this mechanism, the ETS 300 403-1 [11] information element should be set to separate this address from a national or international number. Early implementations of ISDN may need to adopt strict number allocation principles in order to identify the CRF-S uniquely. In either of these solutions, the address is used to enable routing within the ISDN between the CRF-S and a PH.

NOTE 2: The procedures specified in this subclause are only applicable if switched or dynamically provisioned semi-permanent Bd-channels are employed. Semi-permanent Bd-channels (see subclause 11.3) may be used exclusively.

#### 10.4.1 Signalling messages for circuit mode procedures

The messages specified in subclause 10.2.1 are deployed with the following modifications below:

Overlap sending for the establishment of Bd-channels is not supported. Thus, SETUP ACKNOWLEDGE and INFORMATION messages are not supported (see subclause 10.1.2).

##### 10.4.1.1 Connect

The specification in subclause 10.2.1.2 applies with the following addition:

Table 24

Information element	Ref	Direction	Type	Length	PHI
.... User-user	4.5	both	O	2-32	a)

a) The conditions in which the "user-user" information element is mandatory can be deduced from table 47.

##### 10.4.1.2 Setup

The specification in subclause 10.2.1.7 applies with the following addition:

Table 25

Information element	Ref	Direction	Type	Length	PHI
.... Calling party number	4.5	both	O	2-23	b)
.... User-user	4.5	both	O	2-32	a)

a) The conditions in which the "user-user" information element is mandatory can be deduced from table 47.

b) The "calling party number" information element is mandatory in the CRF-P to PH direction. It may be included in the PH to CRF-P direction to identify the PH.

#### 10.4.2 Signalling messages for packet mode procedures

The messages specified in subclause 10.3.1 are deployed with the following modifications below:

##### 10.4.2.1 Connect

The specification in subclause 10.3.1.2 applies with the following addition:

**Table 26**

Information element	Ref	Direction	Type	Length	PHI
.... User-user	4.5	both	O	2-32	a)

- a) The conditions in which the "user-user" information element is mandatory can be deduced from table 47.

#### 10.4.2.2 Setup

The specification in subclause 10.3.1.7 applies with the following addition:

**Table 27**

Information element	Ref	Direction	Type	Length	PHI
.... User-user	4.5	both	O	2-32	a)

- a) The conditions in which the "user-user" information element is mandatory can be deduced from table 47.

#### 10.4.3 Procedures for Bd-channels established by the CRF-S (CRF-P to PH)

(See figure B.10)

A terminal requires the establishment of a data link to the PH by sending a SABME-frame with a SAPI value 16. If no Bd-channel exists between the FH serving this terminal and the PH, the CRF-S initiates the establishment of a dynamic Bd-channel. The address of the PH access which is placed in the "called party number" information element is derived from CRF-S internal OA&M data. This number will be used to route the call for the Bd-channel establishment to the appropriate PH access.

The establishment of a Bd-channel follows, in general, the establishment of a switched ISDN connection using either circuit mode procedures (see ETS 300 403-1 [11] considering the restrictions specified in subclause 10.2.2) or packet mode procedures (see ETS 300 007 [20] considering the restrictions specified in subclause 10.3.2). However, the following modifications apply:

- if circuit mode procedures are deployed, the "bearer capability" information element in the SETUP message is coded as specified in clause H.1;
- if packet mode procedures are deployed, the "bearer capability" information element in the SETUP message is coded as specified in clause H.3;
- in case of dynamic provisioning of semi-permanent Bd-channels, the CRF-S sets the "Type of service" information element to "Semi-permanent service". For switched Bd-channels, the CRF-S may set the "Type of service" information element to "Regular service". The type of service is communicated to the PH in the "user-user" information element. Distinction between semi-permanent and switched Bd-channels is required in the PH, e.g. in order to start TPHI or not.
- the "calling party number" information element contains the address of the calling CRF-S. If a national number is used instead of an address and without any further agreement between the CRF-P and the PH, the calling party number shall be coded as a national number;

NOTE: The "calling party number" information element is used by the PH to determine whether this B-channel establishment is intended for a Bd-channel. The PH compares this information element against an internal list (provided through OA&M mechanisms) of CRF-S addresses. If no match is found, the establishment is intended for a Bb-channel (user B-channel service case A or case B, depending on the coding of the "bearer capability" information element) and the procedures as defined in subclauses 10.2.2 or 10.3.2 are utilized. Otherwise, the PH uses the "calling party number" information element to determine to which CRF-S the newly established Bd-channel is connected.

- if the CRF-S implements decentralized FHs (i.e., sub-bundles), the CRF-S includes in the initial message for the Bd-channel establishment the appropriate "FH reference number"; this reference number is communicated to the PH in the "user-user" information element;
- in its associated CONNECT message, the PH communicates in the "user-user" information element the Bd-channel reference number of the new Bd-channel.

Alternatively, the CRF-S may establish Bd-channels without any terminal requiring the establishment of a data link; the establishment is then instigated by an OA&M mechanism.

If the Bd-channel established is the first Bd-channel between the PH and a CRF-S, the PH establishes a signalling data link (see subclause 9.3).

Subsequent layer 2 and layer 3 connection establishment is specified in subclause 10.5.

The CRF-P shall support the calling line identification presentation supplementary service.

#### **10.4.4 Procedures for Bd-channels established by the PH (PH to CRF-P)**

(See figures B.11 and B.12)

From an analysis of a sufficient number of leading digits of the "called address" of the incoming ITU-T Recommendation X.25 [4] "call request" packet and by consulting an internal list (provided through OA&M mechanisms) of CRF-S addresses, the PH derives an appropriate CRF-S address.

The establishment of a Bd-channel follows, in general, the establishment of a switched ISDN connection using either circuit mode procedures (see ETS 300 403-1 [11] considering the restrictions specified in subclause 10.2.2) or packet mode procedures (see ETS 300 007 [20] considering the restrictions specified in subclause 10.3.2). However, the following modifications apply:

- if circuit mode procedures are deployed, the "bearer capability" information element in the SETUP message is coded as specified in clause H.1;
- if packet mode procedures are deployed, the "bearer capability" information element in the SETUP message is coded as specified in clause H.3;
- the "called party number" information element in the SETUP message contains the address of a CRF-S. If a national number is used instead of an address and without any further agreement between the CRF-P and the PH, the called party number shall be coded as a national number;

NOTE: The PH derives this information from analysis of a sufficient number of leading digits of the "called address" of the incoming ITU-T Recommendation X.25 [4] "call request" packet and by consulting an internal list (provided through OA&M mechanisms) of CRF-S addresses.

- no "called party subaddress" information element is sent in the SETUP message;
- the PH may insert in the "calling party number" information element of the SETUP message the address of the PH access. If a national number is used instead of an address and without any further agreement between the CRF-P and the PH, the called party number shall be coded as a national number;

- no "calling party subaddress" information element is sent in the SETUP message;
- in the SETUP message, the PH communicates in the "user-user" information element the "Bd-channel reference number" of the new Bd-channel. If the CRF-S implements sub-bundles, the "user-user" information element shall contain in addition the "FH reference number" or the CCITT Recommendation E.164 [13] number of the subscriber derived from the "called address" of an incoming ITU-T Recommendation X.25 [4] "call request" (but not both);

the CCITT Recommendation E.164 [13] number of the subscriber derived from the "called address" of the incoming ITU-T Recommendation X.25 [4] "call request" is communicated only if the first Bd-channel between the PH and the CRF-S shall be established due to an incoming ITU-T Recommendation X.25 [4] "call request" not destined for a PLL service. In all other cases, the "FH reference number" is communicated;

when the CRF-S receives in the "user-user" information element a "called party number" field and if there exists some problem with this number (e.g., the number stipulates a FH unsuitable for a signalling data link or number un-allocated, etc.), the CRF-S may connect the Bd-channel with a FH of its own choice. In addition, the CRF-S may ignore the "called party number"; in this case, the CRF-S shall connect the Bd-channel with a FH of its own choice;

- if the CRF-S implements sub-bundles, the CRF-S includes in its connecting reply message the appropriate "FH reference number"; this reference number is communicated to the PH in the "user-user" information element in the CONNECT message.

Alternatively, the PH may establish Bd-channels without any association with an incoming ITU-T Recommendation X.25 [4] "call request"; the establishment is then instigated by an OA&M mechanism. If sub-bundles are implemented, the OA&M mechanism shall also supply the "FH reference number"; this number shall be included in the "user-user" information element.

If the Bd-channel established is the first Bd-channel between the PH and the CRF-S, the PH establishes a signalling data link (see subclause 9.3).

Subsequent layer 2 and layer 3 connection establishment is specified in subclause 10.5.

#### **10.4.5 Procedures for Bd-channel access connection clearing**

(See figure B.13)

The procedures specified in subclause 5.3 of ETS 300 403-1 [11] together with the exceptions detailed in subclauses 10.2.4 and 10.3.4 apply with the following alteration:

Timer TPHI governs the release of Bd-channels (see subclause 10.7).

#### **10.5 D-channel services, switched, case B**

The following subclauses specify the messages, the information elements, and the procedures required for dynamic data link establishment in a Bd-channel. The messages are conveyed between the CRF-S and the PH via the signalling data link in a Bd-channel.

### 10.5.1 Signalling messages

The following table defines the messages for dynamic data link establishment; they are derived from annex B of ETS 300 007 [20].

**Table 28**

	<b>Ref. to ETS 300 007</b>	<b>Restriction for PHI</b>
Data link establishment messages CONNECT RELEASE RELEASE COMPLETE SETUP	B.3 B.7 B.8 B.9	a) a)
Miscellaneous messages STATUS	B.10	b)

- a) This message is used only if the FH implements a frame relaying technique.
- b) This message is used only in recovery situations as specified in ETS 300 403-1 [11] subclause 5.8.

The "Direction", "Type", and "Length" column in the tables in the following subclauses refer to the signalling messages on the signalling data link on the Bd-channels. In the "Direction" column, "C>P" indicates that the information element is only sent in the CRF-S to PH direction; "P>C" designates the PH to CRF-S direction.

The coding of the content of the "user-user" information element is specified in clause 13.

#### 10.5.1.1 Connect

This message is sent by the PH to the CRF-S and by the CRF-S to the PH to indicate acceptance of the data link establishment.

Message Type : CONNECT

Direction : both

**Table 29**

<b>Information element</b>	<b>Ref</b>	<b>Direction</b>	<b>Type</b>	<b>Length</b>
Protocol discriminator	4.2	both	M	1
Call reference	4.3	both	M	2-3
Message type	4.4	both	M	1
User-user	4.5	both	M	3-32

#### 10.5.1.2 Release

This message is sent by the PH to the CRF-S to indicate that the PH has disconnected the data link and the call reference and that the CRF-S should release the association between the DLCI value and the subscriber identity and prepare to release the call reference after sending the RELEASE COMPLETE message.

Message type : RELEASE

Direction : PH to CRF-S



**Table 30**

Information element	Ref	Direction	Type	Length
Protocol discriminator	4.2	P>C	M	1
Call reference	4.3	P>C	M	2-3
Message type	4.4	P>C	M	1
Cause	4.5	P>C	M	4-32

**10.5.1.3 Release complete**

This message is sent by the PH or the CRF-S. If the CRF-S implements a frame relaying technique, this message is only sent by the CRF-S to indicate that the CRF-S has released the association between the DLCI value and the subscriber identity and has released the call reference and that the PH shall release the call reference. If the CRF-S implements a frame switching technique, this message indicates the sending equipment accepts or rejects the data link establishment and that it released the call reference; the receiving equipment should release the call reference as well.

Message type : RELEASE COMPLETE

Direction : both

**Table 31**

Information element	Ref	Direction	Type	Length
Protocol discriminator	4.2	both	M	1
Call reference	4.3	both	M	2-3
Message type	4.4	both	M	1
Cause	4.5	both	O a)	2-32
User-user	4.5	both	O b)	2-32

- a) The "cause" information element is mandatory, unless the RELEASE COMPLETE message is sent to confirm the release of the call reference only; in the latter case, the "cause" information element is not sent.
- b) If this message confirms the establishment of a data link, the "user-user" information element is mandatory in both directions; if this message confirms the release of the call reference only, this information element is not sent.

**10.5.1.4 Setup**

This message is sent by the PH to the CRF-S and by the CRF-S to the PH to initiate the data link establishment.

Message type : SETUP

Direction : both

Table 32

Information element	Ref	Direction	Type	Length
Protocol discriminator	4.2	both	M	1
Call reference	4.3	both	M	2-3
Message type	4.4	both	M	1
Bearer capability	4.5	both	M	7
Calling party number	4.5	both	O a)	2-23
Calling party subaddress	4.5	P>C	O b)	2-23
Called party number	4.5	P>C	M	4-24
Called party subaddress	4.5	P>C	O c)	2-23
User-user	4.5	C>P	M	3-32

- a) The "calling party number" information element is mandatory in the CRF-S to PH direction. It may be included in the PH to CRF-S direction if the PH implements ITU-T Recommendation X.25 [4] to information element mapping and provides indication to the called TE of the "calling party number".
- b) The "calling party subaddress" information element may be included in the PH to CRF-S direction if the PH implements ITU-T Recommendation X.25 [4] to information element mapping and provides indication to the called TE of the "calling party subaddress".
- c) The "called party subaddress" information element may be included in the PH to CRF-S direction if the PH implements ITU-T Recommendation X.25 [4] to information element mapping and provides indication to the called TE of the "called party subaddress".

**10.5.1.5 Status**

This message is sent by the PH or the CRF-S at any time to report certain error conditions listed in subclause 5.8 of ETS 300 403-1 [11].

Message type : STATUS

Direction : both

Table 33

Information element	Ref	Direction	Type	Length
Protocol discriminator	4.2	both	M	1
Call reference	4.3	both	M	2-3
Message type	4.4	both	M	1
Cause	4.5	both	M	4-32

**10.5.2 Procedures for data link establishment by the CRF-S (CRF-S to PH)**

(See figures B.14 and B.15)

A terminal requires the establishment of a data link to the PH by sending a SABME-frame with a SAPI value 16. This initiates the following procedure between the CRF-S and the PH:

- a) if no Bd-channel exists between the FH serving this terminal and the PH and dynamic Bd-channel establishment is supported, the CRF-S initiates the establishment of a dynamic Bd-channel (see subclause 10.4.3);
- b) for PLL and semi-permanent D-channel services, no signalling is required as all necessary data for the data link have been established by some OA&M procedures (see clause 11). In this case, the CRF-S selects a Bd-channel (if decentralized FHs are implemented, in the appropriate sub-bundle) and proceeds directly with the data link establishment in the selected Bd-channel;

- c) if a Bd-channel can not be established, the CRF-S shall report the exception as specified in subclause 12.3.1 to the terminal trying to establish a data link;
- d) as soon as a signalling data link between the CRF-S and the PH and a Bd-channel between the FH serving the terminal requesting the data link and the PH exists, the CRF-S sends a SETUP message with the following information elements according to subclause 10.5.1 to the PH. In particular, the following specifications apply:
  - in the SETUP message, the "bearer capability" information element is coded as specified in annex H, clause H.4;
  - in the "calling party number" information element the CRF-S conveys to the PH the identity of the subscriber that is requesting the data link establishment. Without any further agreement between the CRF-S and the PH, the "calling party number" information element shall be coded as a national number;
  - the "DLCI value" for this new data link is included in the "user-user" information element;
  - if sub-bundles are implemented, the "FH reference number" is included in the "user-user" information element as well.

The verified "calling party number" is required by the PH for charging purposes and profile selection. Whenever the SETUP message does not contain a "network provided" "calling party number", the PH will reject the outgoing call. The PH uses the "calling party number" also to verify or complement the "calling address" in the outgoing ITU-T Recommendation X.25 [4] "call request" packets.

If no response to the SETUP message is received, the SETUP message is repeated. The procedure is controlled by timer T303. If the repetition is not successful, the CRF-S shall initiate the clearing procedures towards the calling user;

- e) upon receipt of the SETUP message, the PH selects a Bd-channel (in the appropriate sub-bundle) dependent on the traffic load in the Bd-channels. If all available Bd-channels already are saturated with traffic, the PH establishes a new dynamic Bd-channel using the received FH reference number (see subclause 10.4.4);
- f) if the CRF-S implements a frame relaying technique, the PH answers with a CONNECT message according to subclause 10.5.1, the call reference is retained for later notification of the data link disconnection (see subclause 10.5.4). In the "user-user" information element, the "Bd-channel reference number" of the selected Bd-channel is communicated to the CRF-S. The PH also starts timer TPH for the new data link;
- g) if the CRF-S implements a frame switching technique, the PH answers with a RELEASE COMPLETE message according to subclause 10.5.1 and the call reference is released. In the "user-user" information element, the "Bd-channel reference number" of the selected Bd-channel is communicated to the CRF-S. The PH also starts timer TPH for the new data link. The "cause" information element is set to "31" (normal, unspecified);

NOTE: The deployment of frame switching or frame relaying technique is a per CRF-S option, both types of CRF-Ss may be supported simultaneously on the same PH.

- h) in both cases, the necessary information for the data link establishment is now available for both the FH and the PH and the CRF-S can transmit a transcription of the SABME-frame originally received from the subscriber;
- j) the timer TPH is stopped upon receipt of a SABME-frame. If timer TPH expires before the PH receives a SABME-frame, the PH shall consider the data link as disconnected and the association between the DLCI value and the CCITT Recommendation E.164 [13] number of the originating subscriber access as terminated. If the CRF-S implements a frame relaying technique, the PH initiates the signalling procedures for data link disconnection (see subclause 10.5.4) using the cause value "102" (recovery on timer expiry) and the diagnostic code "0" (no additional information);

- k) if, for some reason, the PH can not accept a new data link (e.g., temporary network congestion), the PH rejects the data link establishment request with a RELEASE COMPLETE message according to subclause 10.5.1 supplying an appropriate cause value from the classes "010" (resource not available), "011" (service or option not available), or "100" (service or option not implemented).

### 10.5.3 Procedures for data link establishment by the PH (PH to CRF-S)

(See figures B.17 and B.18)

Upon receipt of an incoming ITU-T Recommendation X.25 [4] "call request", the PH derives the CCITT Recommendation E.164 [13] number of the subscriber from the "called address" of the ITU-T Recommendation X.25 [4] "call request". From an analysis of a sufficient number of leading digits of the "called address" of the incoming ITU-T Recommendation X.25 [4] "call request" packet and by consulting an internal list (provided through OA&M mechanisms) of CRF-S addresses, the PH also determines the appropriate CRF-S.

The receipt of a ITU-T Recommendation X.25 [4] "call request" at the PH together with the OA&M data available to the PH, causes the PH to initiate the following procedure between the CRF-S and the PH:

- a) if dynamic Bd-channels are supported, the PH establishes a new Bd-channel (see subclause 10.4.4) in the following cases:
- no Bd-channel to the CRF-S in question exists yet;
  - if sub-bundles are supported and a Bd-channel is required in a particular sub-bundle (e.g. the incoming ITU-T Recommendation X.25 [4] "call request" is destined for a PLL service).
- b) if a signalling data link and a Bd-channel exists already between the CRF-S and the PH, the PH sends a SETUP message according to subclause 10.5.1 in the signalling data link to the CRF-S. In the particular, the following specifications apply:
- in the SETUP message, the "bearer capability: information element is coded as specified in clause H.4;
  - the "called party number" information element in the SETUP message contains the CCITT Recommendation E.164 [13] number derived from the "called address" of the incoming ITU-T Recommendation X.25 [4] "call request". Without any further agreement between the PH and the CRF-S, the called party number shall be coded as a national number;
  - if the PH implements ITU-T Recommendation X.25 [4] to information element mapping and provides indication to the called TE of the "called party subaddress" in the SETUP message; the content of this information element is derived from the "called address extension" of the incoming ITU-T Recommendation X.25 [4] "call request";
  - if the PH implements ITU-T Recommendation X.25 [4] to information element mapping and provides indication to the called TE of the "calling party number" in the SETUP message; the content of this information element is derived from the "calling address" of the incoming ITU-T Recommendation X.25 [4] "call request". Without any further agreement between the CRF-P and the PH, the calling party number shall be coded as a national number. In addition, the numbering plan, i.e. CCITT Recommendation E.164 [13] or X.121 [5], shall be indicated;
  - if the PH implements ITU-T Recommendation X.25 [4] to information element mapping, and provides indication to the called TE of the "calling party subaddress" in the SETUP message; the content of this information element is derived from the "calling address extension" of the incoming ITU-T Recommendation X.25 [4] "call request".

The CRF-S shall accept the "calling party number" provided by the PH. The PH shall indicate a "network provided" screening and the presentation indicator shall be set to "presentation allowed". The CRF-S shall not replace it with the address of the PH.

If no response to the SETUP message is received, the SETUP message is repeated. The procedure is controlled by timer T303. If the repetition is not successful, the PH clears the call;

- c) the CRF-S offers the call to the subscriber using standard ETS 300 007 [20] clause 7 procedures;
- d) if, for some reason, (e.g., due to traffic saturation in a particular FH), the CRF-S can not accept the establishment of a new data link, it shall send a RELEASE COMPLETE message to the PH according to subclause 10.5.1 supplying an appropriate cause value from the classes "010" (resource not available), "011" (service or option not available), or "100" (service or option not implemented). The PH clears the incoming virtual call towards the calling ITU-T Recommendation X.25 [4] DTE using the appropriate cause from table 6 of ETS 300 007 [20];
- e) if the CRF-S implements a frame relaying technique, the CRF-S sends a CONNECT message according to subclause 10.5.1 to the PH, the call reference is retained for later notification of the data link disconnection (see subclause 10.5.4).

In particular, the following specifications apply:

- the "DLCI value" for the new data link is communicated to the PH in the "user-user" information element;
- if sub-bundles are implemented, the "FH reference number" of the appropriate sub-bundle is communicated in the "user-user" information element as well;
- f) If the CRF-S implements a frame switching technique, the CRF-S answers with a RELEASE COMPLETE message according to subclause 10.5.1 and the call reference is released. In particular, the following specifications apply:
  - the "DLCI value" for the new data link is communicated to the PH in the "user-user" information element;
  - if sub-bundles are implemented, the "FH reference number" of the appropriate sub-bundle is communicated in the "user-user" information element as well;
  - the "cause" information element is set to "31" (normal, unspecified);

NOTE: The deployment of frame switching or frame relaying technique is a per CRF-S option, both types of CRF-Ss may be supported simultaneously on the same PH.

- g) the CRF-S starts timer TCRF for the new data link;
- h) upon receipt of the acceptance of the new data link, the PH selects a Bd-channel (in the appropriate sub-bundle) dependent on the traffic load in the Bd-channels. If no Bd-channel is available or all available Bd-channels already are saturated with traffic, and dynamic Bd-channel establishment is supported, the PH establishes a new dynamic Bd-channel (see subclause 10.4.4);
- j) the PH now transmits a SABME-frame in the selected Bd-channel with the indicated DLCI to the CRF-S. The CRF-S shall be prepared to accept the SABME-frame on any Bd-channel (in the sub-bundle) which exists between the FH and the PH; the correlation between this SABME-frame and the previous signalling exchange is performed by means of the DLCI value;
- k) the timer TCRF is stopped upon receipt of the SABME-frame. If the timer TCRF expires before a SABME-frame is received from the PH on any of the Bd-channels, the CRF-S shall regard the data link as disconnected. Nothing shall be sent to the TE but the CRF-S shall consider the association between the selected DLCI and the subscriber access together with the TEI value as terminated as if a link disconnection procedure had been exercised. In addition, if the CRF-S implements a frame relaying technique, it shall initiate data link clearing by sending a RELEASE COMPLETE message to the PH containing a cause value "102" (recovery on timer expiry). The PH, upon receipt of this RELEASE COMPLETE message, shall initiate the clearing of the incoming ITU-T Recommendation X.25 [4] "call request" towards the originating DTE using the cause value "17" (remote procedure error) and diagnostic code 64;

- l) if the subscriber does not accept the call, the CRF-S sends a RELEASE COMPLETE message according to subclause 10.5.1 to the PH indicating the reason in the "cause" information element (see subclause 7.4.3 of ETS 300 007 [20]). The PH clears the incoming virtual call towards the calling ITU-T Recommendation X.25 [4] DTE using the appropriate cause from table 6 of ETS 300 007 [20].

**10.5.4 Procedures for data link disconnection**

(See figures B.20 and B.21)

After the last virtual circuit on a data link is cleared, the PH starts timer T320. If a new virtual circuit is established (either outgoing or incoming), timer T320 is stopped. Timer T320 is also stopped if the subscriber disconnects the data link.

On the expiry of timer T320, the PH disconnects the data link.

If a CRF-S implements a frame switching technique, it is aware of any data link disconnection, no additional signalling is required.

However, if a CRF-S implements a frame relaying technique, it is in general unaware of data link disconnections; these events shall be signalled from the PH to the CRF-S. The following procedure shall be deployed:

- a) the PH sends a RELEASE message according to subclause 10.5.1 to the CRF-S using the call reference that was preserved after signalling for the data link establishment (see subclauses 10.5.2 and 10.5.3). If the subscriber disconnected the data link, the cause value shall be set to "31" (normal, unspecified); if the PH disconnected the data link after expiry of T320, the cause value shall be set to "102" (recovery on timer expiry) with diagnostic "0" (no additional information);
- b) the CRF-S releases any association between the data link in the subscriber access and the Bd-channel and returns a RELEASE COMPLETE message according to subclause 10.5.1 to the PH. The call reference can now be released as well.

**10.5.5 Procedures after receipt of a STATUS message**

If the PH or the CRF-S receives a STATUS message, it shall return a RELEASE COMPLETE message using the cause specified in the received STATUS message. An alarm may be issued.

**10.6 Restart on the D64-channel**

This subclause specifies the restart messages and procedures applicable to the D-channel of the PHI. The procedures are not applicable on the signalling data link in the Bd-channel.

**10.6.1 Signalling messages**

The following table is derived from subclause 3.4 of ETS 300 403-1 [11].

**Table 34**

	<b>Ref. to ETS 300 403-1 [11]</b>	<b>Restriction for PHI</b>
Messages: SEGMENT (CEPT Note) RESTART RESTART ACKNOWLEDGE STATUS	annex K 3.4.1 3.4.2 3.4.3	N/A

The CRF-P processes the messages indicated in the table and their information elements according to ETS 300 403-1 [11]. The PH also processes the message indicated in the table according to ETS 300 403-1 [11], unless an exception is specified below.

N/A: This message is not supported on the PHI; if this message is received by the PH, it will be treated like an unknown message (see subclause 5.8 of ETS 300 403-1 [11]).

NOTE: The term "user" refers to the PH, the term "network" to the CRF-S.

### 10.6.1.1 Restart

This table is derived from subclause 3.4.1 of ETS 300 403-1 [11].

**Table 35**

Information element	Ref	Direction	Type	Length	PHI
Protocol discriminator	4.2	both	M	1	
Call reference	4.3	both	M	2-3	a)*
Message type	4.4	both	M	1	
Channel identification	4.5	both	O	2-*	b)*
Restart indicator	4.5	both	M	3	

a)\* Only the global call reference is permitted.

b)\* Included when necessary to indicate the particular channel(s) to be restarted.

### 10.6.1.2 Restart acknowledge

This table is derived from subclause 3.4.2 of ETS 300 403-1 [11].

**Table 36**

Information element	Ref	Direction	Type	Length	PHI
Protocol discriminator	4.2	both	M	1	
Call reference	4.3	both	M	2-3	a)*
Message type	4.4	both	M	1	
Channel identification	4.5	both	O	2-*	b)*
Restart indicator	4.5	both	M	3	

a)\* Only the global call reference is permitted.

b)\* Included when necessary to indicate the particular channel(s) which have been restarted.

### 10.6.1.3 Status

This table is derived from subclause 3.4.3 of ETS 300 403-1 [11].

**Table 37**

Information element	Ref	Direction	Type	Length	PHI
Protocol discriminator	4.2	both	M	1	
Call reference	4.3	both	M	2-3	a)
Message type	4.4	both	M	1	
Cause	4.5	both	M	4-32	
Call state	4.5	both	M	3	

a) Only the global call reference is permitted.

### 10.6.2 Restart procedure

The restart procedure as specified in subclause 5.5 of ETS 300 403-1 [11] with the additions mentioned in subclauses 7.4.1 and 7.4.3 of ETS 300 007 [20] apply.

NOTE: The term "user" refers to the PH, the term "network" to the CRF-S.

## 10.7 The timers T320, TPHI, TPH, and TCRF

Whereas in the B-channel service, the timer T320 is associated with the Bb-channel layers 1 and 2 and an expiry of the timer triggers both the disconnection of the data link and the release of the Bb-channel, in the D-channel service, timer T320 governs only the data link, ie., layer 2. Upon its expiry, the data link is disconnected.

The layer 1 of a Bd-channel is supervised by the timer TPHI. It is activated when the last subscriber data link in the Bd-channel is disconnected. Upon its expiry, the Bd-channel is released.

A PH may implement two types of timers TPHI. The first type, TPHIa is used for ordinary Bd-channels whereas timer TPHIb is used for the Bd-channel carrying the signalling data link. The latter is only activated when the last data link in the whole bundle is disconnected. In general, TPHIb is set to a larger value than TPHIa; this assures that the signalling data link has a longer persistence than subscriber data links.

NOTE 1: A PH may implement timer TPHIb such that it governs not only the Bd-channel with the signalling data link but also other Bd-channels (typically one more) to assure that, in case of a failure, a backup for the signalling data link can be achieved without the necessity to first establish a Bd-channel.

The CRF-S implements a timer TCRF which supervises the data link establishment in the Bd-channel after successful inband call setup. TCRF starts upon the sending of the RELEASE COMPLETE or CONNECT message to the PH and stops upon the reception of a SABME-frame from the PH. At the expiry of TCRF, the data link is released.

The PH implements a timer TPH which supervises the data link establishment in the Bd-channel after successful inband call setup. TPH starts upon the sending of the RELEASE COMPLETE or CONNECT message to the CRF and stops upon the reception of a SABME-frame from the CRF. At the expiry of TPH, the data link is released.

NOTE 2: The CRF-S does not implement T320, TPH or TPHI; the PH does not implement timer TCRF.

The following default timer values are suggested:

Table 38

Timer	Use	Default value
T320	see subclause 5.2.3	30 s
TPH	dynamic data link establishment	30 s
TCRF	dynamic data link establishment	30 s
TPHI	switched Bd-channels	60 s

## 11 Static and dynamic provisioning for PLL and semi-permanent services

### 11.1 General Introduction

This clause lists only the requirements on the signalling messages, the signalling procedures, and the information elements. Any specific coding is conforming to ETS 300 403-1 [11] or ITU-T Recommendation Q.932 [2] or is detailed in clause 13.

#### 11.1.1 Signalling procedures

The signalling for the dynamic provisioning for semi-permanent Bd-channel establishment and release on the PHI is according to subclause 10.4; in the following subclauses, only deviations from that subclause are described.



The signalling on the signalling data link in the Bd-channels for the dynamic provisioning of PLLs or semi-permanent data links is according to ITU-T Recommendation Q.932 [2]; in the following subclauses, only deviations from that Recommendation are described.

### **11.1.2 Signalling messages**

The signalling messages used on the PHI are listed in the following subclauses.

### **11.1.3 Information elements**

The information elements transported in the signalling messages on the signalling link are completely listed in subclause 11.4.

## **11.2 B-channel services, case A and case B, semi-permanent**

### **11.2.1 Static provisioning**

On both sides, the CRF-S and the PH, OA&M data has to be provided but no signalling is required.

NOTE: Also at the TE, the CRF-P, and possibly other equipment in the ISDN, OA&M data are required to specify the particular B-channel to be used on the user-network interface.

### **11.2.2 Dynamic provisioning**

Dynamic provisioning of semi-permanent Bb-channels for B-channel services (case A or B) is not supported on the PHI.

NOTE: Long duration switched Bb-channels are not considered semi-permanent.

## **11.3 Semi-permanent Bd-channels**

### **11.3.1 Static provisioning**

On both sides, the CRF-S and the PH, OA&M data has to be provided but no signalling is required.

### **11.3.2 Dynamic provisioning**

(See figures B.22 and B.23)

Dynamic provisioning of semi-permanent Bd-channels is either supported in the direction from the PH to the CRF-S or in the direction from the CRF-S to the PH; alternatively, simultaneous provisioning in both directions may also be supported.

The CRF-P (CRF-S) established a "semi-permanent" Bd-channel according to subclause 10.4.3; however, the presence of the type of service field in the "user-user" information element (code point "semi-permanent") shall deactivate timer TPHI.

The PH establishes a "semi-permanent" Bd-channel according to subclause 10.4.4 but never activates the timer TPHI.

### **11.3.3 Deregistration of dynamically provisioned Bd-channels**

OA&M procedures at the PH or the CRF-S (depending on who initiated the dynamic provisioning) may instigate the reliance of a dynamically provisional (long duration) Bd-channel; this is equivalent to a deregistration procedure. For the releasing of the Bd-channel, the procedures specified in subclause 10.4.4 shall be used.

Failure situations in the network may also lead to a release of the dynamically provisional Bd-channel; this release is also equivalent to a deregistration.

NOTE: OA&M procedures (automatic or manual) may initiate the deregistration of a prematurely released dynamically provisioned Bd-channel.

#### 11.4 D-channel services, PLL

The following subclauses specify the messages, the information elements, and the procedures required for provisioning of PLL data links. The messages are conveyed between the CRF-S and the PH via the signalling data link in a Bd-channel.

##### 11.4.1 PLL data link provisioning, static

On both sides, the CRF-S and the PH, OA&M data has to be provided but no signalling is required.

##### 11.4.2 Messages for dynamic provisioning of PLL data links

The following table defines the messages for dynamic provisioning of PLL data links; they are derived from subclause 7.1 of ITU-T Recommendation Q.932 [2].

**Table 39**

	Reference to Recommendation Q.932 [2]	Restriction for PH
Messages: REGISTER RELEASE COMPLETE	7.1.5 3.1.12 a)	

a) This reference is to ETS 300 403-1 [11].

##### 11.4.2.1 Register

This message is sent by the PH or the CRF-S to indicate to the receiving equipment the registration or deregistration of a PLL service.

**Table 40**

Information element	Ref.	Dir.	Type	Length
Protocol discriminator	4.2 b)	both	M	1
Call reference	4.3 b)	both	M	2-3
Message type	4.4 b)	both	M	1
Facility a)	8.2.2 c)	both	M	8-*

a) The "facility" information element contains one "invoke" component. The "invoke" component is defined in ITU-T Recommendation Q.932 [2]. The coding of the "operation value" is defined in clause 13. The "argument" is defined in subclause 11.4.2.4. The "facility" information element shall not be repeated in the message.

b) This reference is to ETS 300 403-1 [11].

c) This reference is to ITU-T Recommendation Q.932 [2].

##### 11.4.2.2 Release complete

This message is sent by the PH or the CRF-S to indicate to the receiving equipment the acceptance or rejection of a PLL registration or deregistration and that the call reference has been released; the receiving equipment should also release the call reference.

**Table 41**

Information element	Ref.	Dir.	Type	Length
Protocol discriminator	4.2 b)	both	M	1
Call reference	4.3 b)	both	M	2-3
Message type	4.4 b)	both	M	1
Cause	4.5 b)	both	M d)	4-32
Facility a)	8.2.2 c)	both	O	2-*

- a) The "facility" information element contains one "return result" component, one "return error" component, or one "reject" component. All components are defined in ITU-T Recommendation Q.932 [2]. The coding of the "operation value" is defined in clause 13. The "result" of the "return result" component is defined in subclause 11.4.2.5. The "error value" of the "return error" component is defined in subclause 11.4.2.6. The "parameter" of the "return error" component is defined in subclause 11.4.2.7. The "facility" information element shall not be repeated in the message.
- b) This reference is to ETS 300 403-1 [11].
- c) This reference is to ITU-T Recommendation Q.932 [2].
- d) The cause information element is mandatory in this case, as a release complete is always the first message in the release sequence.

**11.4.2.3 The linked identifier of the invoke component**

The linked identifier of the "invoke" component is not supported.

**11.4.2.4 The argument of the invoke component**

The argument of the "invoke" component is a sequence of ETS 300 403-1 [11] information elements and is coded as defined in subclause 8.2.2.9 of ITU-T Recommendation Q.932 [2].

**Table 42**

Information element	Ref.	Dir.	Type	Length
Calling party number	4.5 b)	C>P	O c)	2-24
Called party number	4.5 b)	P>C	O c)	2-23
User-user	4.5 b)	both	M a)	3-32

- a) The coding is specified in clause 13.
- b) This reference is to ETS 300 403-1 [11].
- c) Mandatory if the operation is PLL or semi-permanent registration. Absent in case of deregistration.

**11.4.2.5 The result of the return result component**

The result of the "return result" component is a sequence of ETS 300 403-1 [11] information elements and is coded as defined in subclause 8.2.2.9 of ITU-T Recommendation Q.932 [2].

**Table 43**

Information element	Ref.	Dir.	Type	Length
User-user	4.5	both	O	2-32

**11.4.2.6 The error value of the return error component**

The error value of the "return error" component is coded as specified in clause 13.

#### 11.4.2.7 The parameter of the return error component

The parameter of the "return error" component is a ETS 300 403-1 [11] cause information element and is coded as defined in subclause 8.2.2.9 of ITU-T Recommendation Q.932 [2];

Table 44

Information element	Ref.	Dir.	Type	Length
Cause	4.5	both	M	4-32

#### 11.4.3 Procedures for PLL data link registration by the CRF-S (CRF-S to PH)

(See figure B.24)

Instigated by OA&M data, the following procedure between the CRF-S and the PH apply:

- a) if no Bd-channel exists between the CRF-S and the PH, i.e. no signalling data link exists, and dynamic Bd-channels are supported, the CRF-S initiates the establishment of a dynamic Bd-channel (see subclause 10.4.3);
- b) if a Bd-channel can not be established, the CRF-S issues an alarm. It may try periodically to establish the Bd-channel;
- c) as soon as a signalling data link between the CRF-S and the PH exists, the CRF-S sends a REGISTER message with the information elements according to subclause 11.4.2 to the PH. In particular, the following specifications apply:
  - the operation value is set to "PLL registration", "Long duration PLL registration" or "Long duration PLL with semi-permanent layer 1 registration", depending on the access method to be registered;
  - the CRF-S includes the "calling party number" information element. Thus, the subscriber's identity is communicated to the PH;
  - the CRF-S includes the "DLCI value" for this new data link in the "user-user" information element;
  - if sub-bundles are implemented, the "FH reference number" is included in the "user-user" information element as well;

The verified "calling party number" is required by the PH for charging purposes and profile selection. The PH uses the "calling party number" also to verify or complement the "calling address" in the outgoing ITU-T Recommendation X.25 [4] "call request" packets;

- d) upon receipt of the REGISTER message, the PH answers with a RELEASE COMPLETE message according to subclause 11.4.2 and the call reference is released. In particular, the following specifications apply:
  - the "cause" information element is coded as "31" (normal, unspecified);
  - no result is included in the "return result" component. The sequence and operational value shall be omitted;
- e) although the necessary information for the data link establishment is now available for both the FH and the PH, no data link establishment is attempted at this time. A later SABME-frame from the subscriber or a later incoming ITU-T Recommendation X.25 [4] "call request" will allow either the CRF-S or the PH to send a SABME-frame on a Bd-channel of the specified sub-bundle without any further signalling;

- f) if, for some reason, the PH can not accept a new PLL data link registration, the PH rejects the data link registration by returning in a RELEASE COMPLETE message a "return error" component, coded as specified in subclause 11.4.2. The "cause" information element shall be coded as "31" (normal, unspecified). The "cause" information element in the parameter of the "return error" component shall be coded with an appropriate cause value from ITU-T Recommendation Q.850 [22].

#### 11.4.4 Procedures for PLL data link registration by the PH (PH to CRF-S)

(See figure B.25)

Instigated by OA&M data, the following procedure between the CRF-S and the PH apply:

- a) if no Bd-channel to the CRF-S in question exists yet and dynamic Bd-channels are supported, the PH initiates the establishment of a new Bd-channel (see subclause 10.4.4);
- b) if a Bd-channel can not be established, the PH issues an alarm. It may try periodically to establish the Bd-channel;
- c) as soon as a signalling data link between the PH and the CRF-S exists, the PH sends a REGISTER message with the information elements according to subclause 11.4.2 to the CRF-S. In particular, the following specifications apply:
- the operation value is set to "PLL registration", "Long duration PLL registration" or "Long duration PLL with semi-permanent layer 1 registration", depending on the access method to be registered;
  - the PH includes the "called party number" information element. Thus, the subscriber's identity is communicated to the CRF-S;
  - The "additional subscriber identification" is conveyed in the "user-user" information element also;

The "called party number" uniquely identifies the user-network interface access. This number may be different from the number that identifies the user. The "additional subscriber identification" allows the CRF-S to determine the terminal equipment on this access for which the PLL service is registered;

- d) upon receipt of the REGISTER message, the CRF-S answers with a RELEASE COMPLETE message according to subclause 11.4.2 and the call reference is released. In particular, the following specifications apply:
- the "cause" information element is coded as "31" (normal, unspecified);
  - the CRF-S includes in the result of the "return result" component the "DLCI value" for this new data link in the "user-user" information element;
  - if sub-bundles are implemented, the "FH reference number" is included in the "user-user" information element as well;
- e) although the necessary information for the data link establishment is now available for both the FH and the PH, no data link establishment is attempted at this time. A later SABME-frame from the subscriber or a later incoming ITU-T Recommendation X.25 [4] "call request" will allow either the CRF-S or the PH to send a SABME-frame on a Bd-channel of the specified sub-bundle without any further signalling;
- f) if, for some reason, the CRF-S can not accept a new PLL data link registration, the CRF-S rejects the data link registration by returning in a RELEASE COMPLETE a "return error" component, coded as specified in subclause 11.4.2. The "cause" information element shall be coded as "31" (normal, unspecified). The "cause" information element in the parameter of the "return error" component shall be coded with an appropriate cause value from ITU-T Recommendation Q.850 [22].

#### 11.4.5 Procedures for PLL data link deregistration

(See figures B.26 and B.27).

Deregistration is instigated by OA&M data. In general, deregistration takes place from the same source as the previous registration has been effected. The following procedure between the CRF-S and the PH apply:

- a) if no Bd-channel to the CRF-S in question exists yet and dynamic Bd-channels are supported, the CRF-S or the PH initiates the establishment of a new Bd-channel (see subclauses 10.4.3 or 10.4.4);
- b) if a Bd-channel can not be established, the CRF-S or PH issues an alarm. It may try periodically to establish the Bd-channel;
- c) as soon as a signalling data link between the PH and the CRF-S exists, a REGISTER message is sent with the information elements according to subclause 11.4.2. In particular, the following specifications apply:
  - the operation code is set to "deregistration";
  - the "DLCI value" of the link to be de-registered is included in the "user-user" information element;
  - if sub-bundles are implemented, the "FH reference number" is included in the "user-user" information element as well;
- d) at the receiving side, the association of this DLCI value and the subscriber identity is removed and a RELEASE COMPLETE message according to subclause 11.4.2 is sent and the call reference is released. In particular, the following specifications apply:
  - the "cause" information element is coded as "31" (normal, unspecified);
  - no result is included in the "return result" component. The sequence and operational value shall be omitted;
- e) if a data link with this DLCI value still exists, the PH shall disconnect it. Further, if also ITU-T Recommendation X.25 [4] virtual circuits still existed, the PH shall clear those with a cause value "17" (remote procedure error) and diagnostic code "64" (call setup, call clearing, or registration problem);
- f) if, for some reason, the PH or the CRF-S can not accept the deregistration, the PH or the CRF-S rejects the deregistration by returning in a RELEASE COMPLETE message a "return error" component, coded as specified in subclause 11.4.2. The "cause" information element shall be coded as "31" (normal, unspecified). The "cause" information element in the parameter of the "return error" component shall be coded with an appropriate cause value from ITU-T Recommendation Q.850 [22].

#### 11.5 D-channel services, semi-permanent

##### 11.5.1 Semi-permanent data link provisioning, static

On both sides, the CRF-S and the PH, OA&M data has to be provided but no signalling is required.

##### 11.5.2 Messages for dynamic provisioning of semi-permanent data links

The messages are the same as specified in subclause 11.4.2.

### 11.5.3 Procedures for semi-permanent data link registration

(See figures B.28 and B.29)

The procedures for semi-permanent data link registration are the same as specified for the PLL registration (see subclauses 11.4.3 and 11.4.4) except that the operation value in the "invoke" component is set to "semi-permanent registration".

Also, after completion of the registration, the PH tries to establish the data link. The timer T320 is not enabled for semi-permanent data links.

NOTE: Depending on whether sub-bundles are implemented or traffic load indicates that no suitable Bd-channel for the new data link is available and dynamic Bd-channels are supported, the PH may need to establish a new Bd-channel (see subclause 10.4.4).

Bd-channels carrying semi-permanent data links can not be released as the timer TPHI is not allowed to be started; if the Bd-channel in question was dynamically established, it becomes, thus, a long duration switched Bd-channel.

### 11.5.4 Procedures for semi-permanent data link deregistration

The procedures for the deregistration of semi-permanent data links are the same as for PLL data link deregistration (see subclause 11.4.5).

## 12 Exception handling

During the establishment of Bb or Bd-channels, the treatment of outgoing or incoming calls as well as during the data transfer phase of the ITU-T Recommendation X.25 [4] virtual calls, several exception cases can occur. These cases shall be treated as specified in this clause.

### 12.1 B-channel service (case A and B)

If during the establishment of a Bb-channel an error situation occurs, the situation is dealt with as specified in subclause 5.8 of ETS 300 403-1 [11] with the following alterations: The terms "user" and "network" are replaced by the terms "PH" and "CRF-P".

#### 12.1.1 Outgoing call

Exceptional cases, e.g., no channels available, etc., shall be treated as is done for other ISDN call establishments.

#### 12.1.2 Incoming call

NOTE: This subclause is essentially a transcript of ETS 300 007 [20] subclauses 7.4 and 7.5; whenever there exists a difference between this ETS and ETS 300 007 [20], the specification in ETS 300 007 [20] takes precedence.

##### 12.1.2.1 Unsuccessful call

If a Bb-channel establishment attempt by the PH is rejected, the ITU-T Recommendation X.25 [4] virtual call shall be cleared to the originating side using a clear indication packet with the appropriate cause from table 6 of ETS 300 007 [20].

##### 12.1.2.2 Premature clearing by remote terminal

If a clear request packet is received from the originating terminal prior to the delivery of the ITU-T Recommendation X.25 [4] "call request" to the called subscriber, the PH shall initiate Bb-channel clearing with an appropriate cause value selected from table 7 of ETS 300 007 [20].

### **12.1.2.3 No Bb-channel available**

If the PH receives an incoming ITU-T Recommendation X.25 [4] "call request" for which OA&M data requires a B-channel service and no Bb-channel is currently available, the ITU-T Recommendation X.25 [4] virtual call shall be cleared to the originating side using a clear indication packet with a cause value "5" (network congestion) and diagnostic code "0" (no additional information).

### **12.1.2.4 Data link disconnect**

If the PH attempts to deliver an ITU-T Recommendation X.25 [4] "incoming call" on an already existing data link in a B-channel and the data link disconnects before the PH receives the associated ITU-T Recommendation X.25 [4] "Call Accepted" packet, the ITU-T Recommendation X.25 [4] virtual call shall be cleared to the originating side using a clear indication packet with a cause value "9" (out of order) and diagnostic code "0" (no additional information).

### **12.1.2.5 Acceptance of call on existing B-channel**

With conditional call notification, any ITU-T Recommendation X.25 [4] "incoming call" is offered with ETS 300 007 [20] signalling on the user-network interface only if no data link in a Bb-channel exists already. However, if the subscriber is using supplementary services (e.g. MSN) an ITU-T Recommendation X.25 [4] "incoming call" may be offered on the user-network interface although a B-channel connection to the PH exists already. If the subscriber attempts to accept the new call on the existing B-channel connection, the CRF-S shall clear the call on the user-network interface, considering this as a not allowable user response (in the sense of ETS 300 007 [20], subclause 7.2.2.3).

The PH shall clear the ITU-T Recommendation X.25 [4] virtual call to the originating side using a clear indication packet with a cause value "17" (remote procedure error) and diagnostic code "64" (call setup, call clearing, or registration problem).

### **12.1.3 Call collision**

Call collisions shall be treated as specified in subclause 5.2.4.

### **12.1.4 Data transfer phase**

#### **12.1.4.1 Subscriber disconnects data link**

If the subscriber disconnects the data link while ITU-T Recommendation X.25 [4] virtual calls still exist, the PH shall clear all switched virtual calls towards the remote terminal by sending a clear indication packet with a cause value "17" (remote procedure error) and diagnostic code "64" (call setup, call clearing, or registration problem); on all permanent virtual circuits, a "reset" packet shall be sent towards the remote terminal with a cause value "17" (remote procedure error) and diagnostic code "64" (call setup, call clearing, or registration problem).

#### **12.1.4.2 Bb-channel is cleared**

If a B-channel on the PHI is cleared while ITU-T Recommendation X.25 [4] virtual calls still exist, the PH shall clear all switched virtual calls towards the remote terminal by sending a clear indication packet with a cause value and diagnostic code derived from the B-channel clearing cause information element as specified in table 6 of ETS 300 007 [20]; on all permanent virtual circuits, a reset packet shall be sent towards the remote terminal with a cause value "9" (out of order) and a diagnostic code "0" (no additional information).

#### **12.1.4.3 Restart on PHI**

If the PH receives on the D-channel of the PHI a ETS 300 007 [20] RESTART message and ITU-T Recommendation X.25 [4] virtual calls still exist in Bb-channels governed by this D-channel, the PH shall clear all switched virtual calls towards the remote terminal by sending a clear indication packet with a



cause value "9" (out of order) and diagnostic code "0" (no additional information); on all permanent virtual circuits, a "reset" packet shall be sent towards the remote terminal with a cause value "9" (out of order) and diagnostic code "0" (no additional information).

## **12.2 Bd-channel establishment**

If during the establishment of a Bd-channel an error situation occurs, this situation is dealt with as specified in subclause 5.8 of ETS 300 403-1 [11] with the following alterations: The terms "user" and "network" are replaced by the terms "PH" and "CRF-P".

NOTE: Either or both, the CRF-S and the PH, may issue a network alarm.

### **12.2.1 Bd-channel establishment by the CRF-S**

#### **12.2.1.1 Corrupted "user-user" information element**

The specification in ETS 300 403-1 [11] subclause 5.8.6 applies.

### **12.2.2 Bd-channel establishment by the PH**

#### **12.2.2.1 Corrupted "user-user" information element**

The specification in ETS 300 403-1 [11] subclause 5.8.6 applies.

## **12.3 Switched D-channel service**

The specification in ETS 300 403-1 [11] subclauses 5.8.1 to 5.8.7 and 5.8.11 apply with the following alterations:

- a) the terms "user" and "network" are replaced by the terms "PH" and "CRF-S". No distinction is made as to the direction, i.e., both, the CRF-S and the PH, implement the same procedures;
- b) the term "disconnect and release the B-channel" is replaced with the appropriate term from the following list:
  - at the PH: The association of the incoming virtual call or the "calling party number" and the data link, i.e., the DLCI value, shall be terminated;
  - at the CRF-S: The association of the subscriber access together with the TEI value and the data link, i.e., the DLCI value, shall be terminated;
- c) the term "clear the network connection" is replaced with the appropriate term from the following list:
  - at the PH: The PH shall clear all switched virtual call and any incoming ITU-T Recommendation X.25 [4] "call request" towards the remote terminal by sending a clear indication packet with a cause value "9" (out of order) and diagnostic code "0" (no additional information); on all permanent virtual circuits, a "reset" packet shall be sent towards the remote terminal with a cause value "9" (out of order) and diagnostic code "0" (no additional information);
  - at the CRF-S: The subscriber shall be notified of the exception condition as specified in subclause 12.3.1.

### **12.3.1 Exception resolution using layer 2 procedures**

Whenever an unusual situation has to be signalled to the TE on the user-network interface or between the CRF-S and the PH, and no signalling association exists (outgoing calls on user-network interface or PLL and semi-permanent services in the Bd-channels) or one has ceased to exist, (incoming calls on user-network interface), the procedures specified in this subclause apply.

### 12.3.1.1 Exception reporting on the user-network interface

Exception reporting on the user-network interface due to PHI problems shall be according to the following procedures:

- a) the data link is in the link establishment state:

in this situation, the FH has received a SABME-frame to which no UA-frame has been sent to acknowledge the data link establishment. The FH shall send a DM-frame with the F bit set to the same value as the P bit in the received SABME-frame. Alternatively, the FH may send a regular UA-frame (hence driving the link into the established state) and proceed as specified under b) below;

- b) the data link is in the link established state:

in this state, the FH has received a SABME-frame to which it replied with a UA-frame, or it sent a SABME-frame to which the subscriber replied with a UA-frame. The FH shall send a DISC-frame.

NOTE: These procedures are in alignment with ETS 300 402-2 [10].

### 12.3.1.2 No exception reporting

If the data link is still in the link disconnected state, the CRF-S shall not report any exception situation to the TE.

### 12.3.1.3 Exception reporting on the Bd-channel

For exception resolution in the Bd-channel, both the CRF-S and the PH shall apply identical procedures as described in subclause 12.3.1.1, bullets a) and b).

## 12.3.2 Outgoing call

### 12.3.2.1 No Bd-channel available

If, when the CRF-S receives a SABME-frame from a subscriber, no suitable Bd-channel is available and a necessary Bd-channel can not be established, the CRF-S shall report the exception as specified in subclause 12.3.1.

### 12.3.2.2 Signalling data link disconnection

If after receipt of a SABME-frame from the subscriber and before or during the signalling exchange specified in subclause 10.5.2 the signalling data link to the PH disconnects (either due to a timer expiry in the PH or to a failure), the CRF-S shall act in one of the two following ways:

- a) if a Bd-channel between the CRF-S and the PH still exists, the CRF-S shall await the establishment of a new signalling data link by the PH;
- b) if no further Bd-channel between the CRF-S and the PH exists and the CRF-S is able to establish a necessary Bd-channel, the CRF-S shall establish one according to the procedures defined in subclause 10.4.3. It then shall await the establishment of a new signalling data link by the PH;
- c) If no further Bd-channel between the CRF-S and the PH exists and only the PH is able to establish a necessary Bd-channel, the CRF-S shall await the re-establishment of a new Bd-channel and of a new signalling data link by the PH.

When the PH has successfully (re)established the signalling data link, the CRF-S shall (re)initiate the subclause 10.5.2 signalling.

### 12.3.2.3 Data link establishment rejection

If the PH rejects the data link establishment, i.e., it replies to the SETUP message with a RELEASE COMPLETE message with a "cause" information element, the CRF-S shall report the exception as specified in subclause 12.3.1.1.

NOTE: The rejection might be due to PH congestion, a corrupted SETUP message, missing mandatory information elements, etc.

### 12.3.2.4 Repeated DLCI

If the PH receives a SETUP message from the CRF-S that contains a still active DLCI value, i.e., a data link with this DLCI value already exists in the specified sub-bundle, the PH shall act in one of the two following ways:

- a) if the "calling party number" of the new SETUP message is identical to the one for the still active DLCI, the PH shall respond with a regular CONNECT or RELEASE COMPLETE message depending whether the CRF-S implements a frame relaying or frame switching technique, i.e., the PH accepts the call;
- b) if the "calling party number" of the new SETUP message is not identical to the one for the still active DLCI, the PH shall respond with a RELEASE COMPLETE message containing a cause value "111" (protocol error, unspecified). Upon receipt of this message, the CRF-S shall report the exception as specified in subclause 12.3.1.1.

### 12.3.3 Incoming call

If during an exception condition a Bd-channel was established that later is not utilized, timer TPHI will assure the timely release of this Bd-channel.

#### 12.3.3.1 Unsuccessful call

If a call offering at the user-network interface fails, the CRF-S shall send a RELEASE COMPLETE message to the PH with an appropriate cause value.

Alternatively, the CRF-S might reject the data link establishment request (e.g., due to FH congestion, an corrupted SETUP message, missing mandatory information elements, etc.).

In either case, the ITU-T Recommendation X.25 [4] virtual call shall be cleared by the PH to the originating side using a clear indication packet with the appropriate cause from table 6 of ETS 300 007 [20].

#### 12.3.3.2 Premature clearing by remote terminal

If a clear request packet is received from the originating terminal prior to the completion of the signalling for the data link establishment, the PH shall initiate data link clearing by sending a RELEASE COMPLETE message to the CRF-S with a an appropriate cause value selected from table 7 of ETS 300 007 [20].

The CRF-S shall act in one of the two following ways:

- a) if the call offering procedure across the user-network interface is not yet complete, the CRF-S shall clear the call reflecting the cause value from the RELEASE COMPLETE message received from the PH;
- b) if the call offering procedure across the user-network interface is complete, the CRF-S shall send nothing to the selected TE but consider the association between the selected DLCI and the subscriber access together with the TEI value as terminated as if a data link disconnection procedure would have been exercised.

NOTE: If the data link is established, it is governed by timer T320.

### 12.3.3.3 No Bd-channel available

If the PH receives an incoming ITU-T Recommendation X.25 [4] "call request" for which OA&M data requires a D-channel service and no Bd-channel for a signalling data link is currently available, i.e. the recovery of the signalling data link by the PH as described in subclause 9.4.4 was not successful, the ITU-T Recommendation X.25 [4] virtual call shall be cleared to the originating side using a clear indication packet with a cause value "5" (network congestion) and diagnostic code "0" (no additional information).

If the signalling with the CRF-S according to subclause 10.5.3 indicates an FH reference number for which no or (under traffic load) no new Bd-channel can be established, the PH shall in case the CRF-S implements frame relaying techniques, initiate data link clearing towards the CRF-S by sending a RELEASE message containing a cause value "42" (switching equipment congestion); in case the CRF-S implements frame switching techniques, the PH shall consider the data link as disconnected. The ITU-T Recommendation X.25 [4] virtual call shall be cleared by the PH to the remote side using a clear indication packet with a cause value "5" (network congestion) and diagnostic code "0" (no additional information). In addition, the CRF-S shall send nothing to the selected TE but consider the association between the selected DLCI and the subscriber access together with the TEI value as terminated as if a link disconnection procedure would have been exercised.

### 12.3.3.4 Signalling data link disconnection

If after receipt of an incoming ITU-T Recommendation X.25 [4] "call request", and before or during the signalling exchange specified in subclause 10.5.3 the signalling data link to the CRF-S disconnects (due to a failure), the PH shall act in one of the two following ways:

- a) if a Bd-channel between the PH and the CRF-S still exists, the PH shall establish a new signalling data link in one of the remaining Bd-channels and (re)initiate the subclause 10.5.3 signalling;
- b) if no further Bd-channel between the PH and the CRF-S exists, the PH shall establish a new one according to the procedures defined in subclause 10.4.4. It shall then establish a new signalling data link and (re)initiate the subclause 10.5.3 signalling.

### 12.3.3.5 Acceptance of call on existing data link

With conditional call notification, any incoming ITU-T Recommendation X.25 [4] "call request" is offered with ETS 300 007 [20] signalling on the user-network interface only if no data link in the D-channel exists already. However, if the subscriber is using supplementary services (e.g. MSN) an incoming ITU-T Recommendation X.25 [4] "call request" may be offered on the user-network interface although a data link in the D-channel exists already.

If the subscriber chooses to accept an incoming call on an active data link, the CRF-S shall consider the call to be accepted and communicate to the PH the DLCI value for the active data link portion on the Bd-channel.

### 12.3.3.6 Repeated DLCI

If the PH receives in the reply to a data link establishment request a DLCI value that belongs to an already active data link, the PH shall use the existing data link to deliver the incoming ITU-T Recommendation X.25 [4] call request.

### 12.3.3.7 Data link disconnect

If the PH attempts to deliver an ITU-T Recommendation X.25 [4] "incoming call" on an already existing data link in a Bd-channel and the data link disconnects before the PH receives the associated ITU-T Recommendation X.25 [4] "call accepted" packet, the ITU-T Recommendation X.25 [4] virtual call shall be cleared to the remote side using a clear indication packet with a cause value "9" (out of order) and diagnostic code "0" (no additional information).

#### **12.3.4 Call collision**

Call collisions can occur when the subscriber initiates data link establishment of a new data link concurrently with the arrival of an incoming ITU-T Recommendation X.25 [4] "call request" at the PH. Additional procedures are not required for resolving call collision on Bd-channels at the PHI.

#### **12.3.5 Data transfer phase**

##### **12.3.5.1 Subscriber disconnects data link**

If the subscriber disconnects the data link while ITU-T Recommendation X.25 [4] virtual calls still exist, the PH shall clear all switched virtual circuits towards the remote terminal by sending a clear indication packet with a cause value "17" (remote procedure error) and diagnostic code "64" (call setup, call clearing, or registration problem); on all permanent virtual circuits, a "reset" packet shall be sent towards the remote terminal with a cause value "17" (remote procedure error) and diagnostic code "64" (call setup, call clearing, or registration problem).

##### **12.3.5.2 Bd-channel is cleared**

If due to a failure the Bd-channel carrying data links with still existing ITU-T Recommendation X.25 [4] virtual calls is released, the PH shall clear all switched virtual circuits towards the remote terminal by sending a clear indication packet with a cause value "5" (network congestion) and diagnostic code "0" (no additional information); on all permanent virtual circuits, a reset packet shall be sent towards the remote terminal with a cause value "9" (out of order) and diagnostic code "0" (no additional information).

##### **12.3.5.3 Restart on PHI**

If the PH receives on the D-channel of the PHI a ETS 300 403-1 [11] RESTART message and ITU-T Recommendation X.25 [4] virtual calls still exist in Bd-channels governed by this D-channel, the PH shall clear all switched virtual circuits towards the remote terminal by sending a clear indication packet with a cause value "9" (out of order) and diagnostic code "0" (no additional information); on all permanent virtual circuits, a "reset" packet shall be sent towards the remote terminal with a cause value "9" (out of order) and diagnostic code "0" (no additional information).

#### **12.4 PLL or semi-permanent D-channel service**

##### **12.4.1 Outgoing call**

###### **12.4.1.1 No Bd-channel available**

The procedures specified in subclause 12.3.2.1 apply.

###### **12.4.1.2 SETUP with PLL (semi-permanent) DLCI value**

If the PH receives on the signalling data link a SETUP message with a DLCI value that is registered for a PLL (or semi-permanent) service (and, therefore, is considered to have an active data link), the PH shall respond with a RELEASE COMPLETE message containing a cause value "111" (protocol error, unspecified). Upon receipt of this message, the CRF-S shall report the exception to the TE according to the procedure specified in subclause 12.3.1.1.

NOTE: Either or both, the CRF-S and the PH, may issue a network alarm.

###### **12.4.1.3 SABME with unknown DLCI**

If the PH receives a SABME-frame without previous signalling according to subclause 10.5.2 whose DLCI value is not belonging to a registered PLL (or semi-permanent) service, the PH shall report the exception to the CRF-S according to subclause 12.3.1.3. The CRF-S shall propagate the exception reporting towards the TE according to subclause 12.3.1.1.

NOTE: Either or both, the CRF-S and the PH, may issue a network alarm.

## **12.4.2 Incoming call**

### **12.4.2.1 No Bd-channel available**

If the PH receives an incoming ITU-T Recommendation X.25 [4] "call request" for which OA&M data requires a D-channel PLL (or semi-permanent) service for which no data link exists yet (or under traffic load), and no new Bd-channel can be established for the required sub-bundle, the PH shall clear the incoming ITU-T Recommendation X.25 [4] "call request" by sending a clear indication packet with a cause value "5" (network congestion) and diagnostic code "0" (no additional information) towards the originating terminal.

### **12.4.2.2 SABME with unknown DLCI**

If the CRF-S receives a SABME-frame without previous signalling according to subclause 10.5.3 whose DLCI value is not known by the CRF-S, the CRF-S shall report the exception to the PH according to the procedure specified in subclause 12.3.1.3. The PH shall clear the incoming ITU-T Recommendation X.25 [4] "call request" by sending a clear indication packet with a cause value "17" (remote procedure error) and diagnostic code "64" (call setup, call clearing, or registration problem) towards the originating terminal.

NOTE: Either or both, the CRF-S and the PH, may issue a network alarm.

## **12.4.3 Call collision**

Call collisions can occur when the subscriber initiates data link establishment of a new data link concurrently with the arrival of an ITU-T Recommendation X.25 [4] "call request" at the PH. The collision can occur either on the signalling data link or on the user-network interface.

### **12.4.3.1 Call collision on network-user interface**

A call collision occurs if, due to an incoming ITU-T Recommendation X.25 [4] "call request", the CRF-S sends a SABME-frame to the TE concurrently with the TE trying to establish a data link. In this situation, both SABME-frames shall be acknowledged with UA-frames and the link considered to be established.

### **12.4.3.2 Call collision on the Bd-channel**

If both, the CRF-S and the PH, initiate a data link establishment for a PLL (or semi-permanent) service concurrently on the same Bd-channel, both SABME-frames shall be acknowledged with UA-frames and the link considered to be established.

If, however, the CRF-S selects a different Bd-channel to send the SABME-frame than the PH, the following procedure shall apply:

The PH leaves the SABME-frame from the CRF-S unanswered until the data link it initiated is established. It then replies with a DM-frame to the data link establishment attempted by the CRF-S. The DM-frame is sent according to the procedure specified in subclause 12.3.1.3.

## **12.4.4 Data transfer phase**

The procedures specified in subclause 12.3.5 apply.

## **12.5 PLL or semi-permanent registration or deregistration**

### **12.5.1 Registration and deregistration by the CRF-S**

#### **12.5.1.1 Data link disconnection**

If during a signalling exchange for a PLL or semi-permanent registration the signalling data link disconnects (either due to a timer expiry in the PH or to a failure) the CRF-S shall act as specified in subclause 12.3.2.2 and (re-)initiate the subclause 11.4.3 or 11.4.5 signalling.

#### **12.5.1.2 Repeated DLCI**

If the PH receives a REGISTER message for a registration from the CRF-S that contains a still active DLCI value, i.e., a data link with this DLCI value already exists (or is registered) in the specified sub-bundle, the PH shall act in one of the following two ways:

- a) if the "calling party number" of the new REGISTER message is identical to the one for the still active DLCI and also the registration (PLL or semi-permanent) is identical, the PH shall complete the registration by returning a "return result" component in a RELEASE COMPLETE message;
- b) if the "calling party number" of the new REGISTER message is not identical to the one for the still active DLCI or the registration (PLL or semi-permanent) is not identical, the PH shall return a "return error" component and set the cause value to "111" (protocol error, unspecified). Both, the CRF-S and the PH, may issue an alarm.

#### **12.5.1.3 Unknown deregistration parameter**

If the PH receives a REGISTER message for a deregistration with a DLCI value that is not registered in the sub-bundle specified, the PH shall return a regular "return result" component.

### **12.5.2 Registration or deregistration by the PH**

#### **12.5.2.1 Data link disconnection**

If during the signalling exchange for a PLL or semi-permanent registration or deregistration the signalling data link disconnects (due to a failure), the PH shall act as specified in subclause 12.3.3.6 and (re-)initiate the subclause 11.4.4 or 11.4.5 signalling.

#### **12.5.2.2 Repeated "called party number"**

If the CRF-S receives a REGISTER message from the PH that contains a "called party number" and an "additional subscriber identification" information element which together identify a terminal that has already a data link registered, the CRF-S shall act in one of the following two ways:

- a) if the new registration (PLL or semi-permanent) is identical to the already existing registration, the CRF-S shall complete the registration by returning a "return result" component with the DLCI value and, possibly, FH reference number of the already registered data link;

NOTE: The PH may need this information in order to complete a registration procedure that was interrupted due to the procedure specified in subclause 12.5.2.1.

- b) if the new registration (PLL or semi-permanent) is not identical to the already existing registration, the CRF-S shall reject the registration by returning a "return error" component with a cause value "111" (protocol error, unspecified).

### 12.5.2.3 Repeated DLCI

If the PH receives a RELEASE COMPLETE message from the CRF-S that contains a still active DLCI value, i.e. a data link with this DLCI value already exists (or is registered) in the specified sub-bundle, the PH shall immediately de-register the new and, possibly, the old registration. If a data link with this DLCI value is currently in the link establishment or link established state, the PH shall disconnect this data link. In addition, if ITU-T Recommendation X.25 [4] virtual calls existed on the data link, the PH shall clear all switched virtual circuits towards the remote terminal by sending a clear indication packet with a cause value "17" (remote procedure error) and diagnostic code "64" (call setup, call clearing, or registration problem), on all permanent virtual circuits, a reset packet shall be sent towards the remote terminal with a cause value "17" (remote procedure error) and diagnostic code "64" (call setup, call clearing, or registration problem). An alarm may be generated.

### 12.5.2.4 Unknown deregistration parameter

If the CRF-S receives a REGISTER message for a deregistration with a DLCI value that is not registered in the specified sub-bundle, the CRF-S shall return a regular "return result" component.

## 13 Additional information elements for PHI signalling

### 13.1 Coding rules

Additional information elements are coded according to ETS 300 403-1 [11] and ITU-T Recommendation Q.932 [2].

These information elements are listed in table 45, which also gives the coding of the information element identifiers. In addition the table shows the usage of these information elements for signalling on D64-channel or inband signalling on Bd-channel.

The additional information elements used for signalling on the D64-channel and for the inband signalling link on the Bd-channel are transported in the user-user information element.

The coding of the additional information elements is defined in subclause 13.2.

Table 46 shows the coding of the user-user information element (see ETS 300 403-1 [11], subclause 4.5.29).

Table 47 shows the usage of the additional information elements for signalling on the D64-channel.

Table 48 shows the usage of the additional information elements for inband signalling in case of switched D-channel service.

Table 49 shows the usage of the additional information elements for inband signalling in case of provisioning of PLL and semi-permanent services.



**Table 45: Information element identifier coding**

Information Element Identifier								Inband signalling requirement	D64 signalling requirement	Subclause reference	Max. Length of information element (octets)	
8	7	6	5	4	3	2	1					
0	0	0	0	0	0	0	1	DLCI Value	X		13.2.1	6
	0	0	0	0	0	1	0	Bd-channel reference number	X	X	13.2.2	4
	0	0	0	0	0	1	1	FH reference number	X	X	13.2.3	4
	0	0	0	0	1	0	0	Additional subscriber identification	X		13.2.4	3
	0	0	0	0	1	0	1	Type of service		X	13.2.5	3
	0	0	0	1	0	0	0	Cause	X		13.2.7	32
	1	1	1	0	0	0	0	Called party number		X	13.2.6	23

**Table 46: User-user information element**

8	7	6	5	4	3	2	1	Octet
User-User								
0	1	1	1	1	1	1	0	1
Information Element Identifier								
Length of User-User Contents								2
Protocol Discriminator								3
additional information elements								4 etc.

Protocol Discriminator (Octet 3)

Bits	8	7	6	5	4	3	2	1	
	0	1	1	0	0	0	0	0	PHI signalling

**Table 47: Usage of the information elements for signalling on the D64-channel**

Information Element	SETUP		CONNECT	
	direction	type	direction	type
Bd-channel reference	PH--->CRF	M	PH--->CRF	M
FH reference	PH--->CRF	O note 1	CRF--->PH	O note 2
	CRF--->PH	O note 2		
Type of service	CRF--->PH	O note 3		
Called party number	PH--->CRF	O note 1		
NOTE 1:	For Bd-channel establishment initiated by an incoming call and only in case of a decentralized FH, the FH reference number or the called party number is present, but not both.			
NOTE 2:	Mandatory if decentralized FHs are implemented in the CRF-S. Absent in case of centralized FH.			
NOTE 3:	Mandatory for the establishment of a semi-permanent Bd-channel by the CRF-S.			

**Table 48: Usage of the information elements for inband signalling in case of switched D-channel service**

Information Element	SETUP		CONNECT (note 2)		RELEASE COMPLETE (note 3)	
	direction	type	direction	type	direction	type
DLCI Value	CRF > PH	M	CRF > PH	M	CRF > PH	M
Bd-channel reference			PH > CRF	M	PH > CRF	M
FH reference	CRF > PH	O (note 1)	CRF > PH	O (note 1)	CRF > PH	O (note 1)
NOTE 1:	Mandatory if decentralized FHs are implemented in the CRF-S. Absent in case of centralized FH.					
NOTE 2:	Only used in case of frame relaying. The RELEASE message is also required for frame relaying.					
NOTE 3:	Additional information elements only used in case of frame switching.					

**Table 49: Usage of the information elements for inband signalling in case of dynamic provisioning of PLL and semi-permanent services**

Information Element	OPERATION = REGISTER				OPERATION = REGISTER			
	REGISTER		RELEASE COMPLETE		REGISTER		RELEASE COMPLETE	
	direction	type	direction	type	direction	type	direction	type
DLCI Value	CRF--> PH	M	CRF--> PH	M	both	M		
FH Reference	CRF--> PH	O (note 1)		O (note 1)	both	O (note 1)		
Additional Subscriber Identification	PH -->CRF	M						
Cause			both	O (note 2)			both	O (note2)
NOTE 1:	Mandatory if decentralized FHs are implemented in the CRF-S. Absent in case of centralized FH.							
NOTE 2:	Sent only as part of a "return error" component.							

### 13.2 Coding of the additional information elements

#### 13.2.1 DLCI value

The purpose of the DLCI value information element is to exchange the layer 2 address for establishment of the data link.

The DLCI value information element is coded as shown in table 50.

The maximum length of this information element is 6 octets.

**Table 50: DLCI value information element**

8	7	6	5	4	3	2	1	Octet
DLCI Value								
0	0	0	0	0	0	0	1	1
Information element Identifier								
Length of DLCI value contents								2
DLCI Value								3
								etc.

**Table 51: DLCI Value (Octet 3 etc.)**

8	7	6	5	4	3	2	1	Bits
0	1	0	0	0	0	C/R	0	SAPI = 16
x	x	x	x	x	x	x	0	Link Connection Identifier Octet 1
x	x	x	x	x	x	x	0	Link Connection Identifier Octet 2
x	x	x	x	x	x	x	1	Link Connection Identifier Octet 3

**13.2.2 Bd-channel reference number**

The purpose of the Bd-channel reference number information element is to identify the Bd-channel on the PHI.

The Bd-channel reference number information element is coded as shown in table 52.

The maximum length of this information element is 4 octets.

**Table 52: Bd-channel reference number information element**

8	7	6	5	4	3	2	1	Octet
Bd-channel reference number								
0	0	0	0	0	0	1	0	1
Information Element Identifier								
Length of Bd-channel reference number contents								2
Bd-channel reference number								3
Bd-channel reference number (cont)								3a

Bd-channel reference number (Octet 3 and 3a)

Binary value.

**13.2.3 FH reference number**

The purpose of the FH reference number information element is to identify the decentralized FHs in one CRF-S. The FH reference number information element is coded as shown in table 53.

The maximum length of this information element is 4 octets.

**Table 53: FH reference information element**

8	7	6	5	4	3	2	1	Octet
FH reference number								
0	0	0	0	0	0	1	1	1
Information Element Identifier								
Length of FH reference number contents								2
FH reference number								3
FH reference number (cont)								3a

FH reference number (Octet 3 and 3a)

Binary value.

**13.2.4 Additional subscriber information**

The purpose of "additional subscriber identification" information element is to identify the terminal of a subscriber in case of dynamic provisioning of PLL or semi-permanent D-channel services by the PH. The "additional subscriber identification" information element is coded as shown in table 54.

**Table 54: Additional subscriber identification information element**

8	7	6	5	4	3	2	1	Octet
Additional subscriber identification								
0	0	0	0	0	1	0	0	1
Information element Identifier								
Length of Additional subscriber identification contents								2
0 spare	Additional subscriber identification TEI							3

Additional subscriber identification (Octet 3)

Binary value: Bits 1 through 7 contain the TEI. Bit 7 shall be set to 0 because only non-automatic TEIs are used for PLL and semi-permanent D-channel service.

NOTE: This information is not conveyed from the CRF-S to the PH via PHI signalling; it is incorporated into the PH's PLL or semi-permanent registration data by some OA&M means.

**13.2.5 Type of service**

The purpose of the type of service information element is to indicate the type of channel in case of dynamic provisioning of semi-permanent Bd-channels. These types are:

- regular service (default);
- semi-permanent service.

If this information is not present the regular service is assumed.

The type of service information element is coded as shown in table 55.

The maximum length of this information element is 3 octets.

**Table 55: Type of service information element**

8	7	6	5	4	3	2	1	Octet
Type of service								
0	0	0	0	0	1	0	0	1
Information element Identifier								
Length of type of service contents s								2
1	0	0	0	0	type of service			3
ext	spare				service			

Type of service (octet 3)

Bits 3 2 1

0	0	0	Regular service
0	0	1	Semi-permanent service

all other values are reserved

**13.2.6 Called party number**

The purpose of the called party number information element is to identify the called subscriber in case of the first Bd-channel establishment. This allows the CRF-S to assign the appropriate FH.

The called party number information element is coded according to ETS 300 403-1 [11] subclause 4.5.8.

**13.2.7 Cause**

The purpose of the "cause" information element is to convey information to the PH or the CRF-S why a PLL or semi-permanent data link registration is rejected.

The cause information element is coded according to ETS 300 403-1 [11] clause 4.

**13.3 Coding of the facility Information Element**

The "facility" information element used in the REGISTER and RELEASE COMPLETE messages for dynamic provisioning (see clause 11) is coded according to ITU-T Recommendation Q.932 [2]. The general structure is shown in table 56.

**Table 56: Facility information element**

8	7	6	5	4	3	2	1	Octet
Facility								
0	0	0	1	1	1	0	0	1
Information element Identifier								
Length of Facility Contents								2
1	0	0						
1	spare			Service discriminator				3
component (note)								4
NOTE: For the PHI, the facility information element contains only one component.								

Service discriminator  
Bits

5 4 3 2 1

---

1 1 0 1 1 Discriminator for PHI registrations

**13.3.1 Embedded information elements**

The argument of the "invoke" component and the result of the "return result" component contain zero, one, or more information elements specified either in ETS 300 403-1 [11] or in subclauses 13.1 and 13.2. If no information element is contained, the whole argument or result is absent. In the other cases, the information elements are coded as specified in subclause 8.2.2.9 of ITU-T Recommendation Q.932 [2].

**13.3.2 Operation value**

The purpose of the operation value in the "invoke" component is to differentiate between the various registration options.

The operation value is coded as shown in table 57.

The length of the operation value is 1 octet.

**Table 57: Operation value**

8	7	6	5	4	3	2	1	Octet
0	0	0	0	0	Operation value			1

Operation value (octet 1)

Bits	3	2	1	
	0	0	1	PLL Registration
	0	1	0	Semi-permanent Registration
	0	1	1	Deregistration
	1	0	0	Long duration PLL Registration
	1	0	1	Long duration PLL with semi-permanent layer 1 Registration

**13.3.3 Error value**

The error value is a mandatory part of the "error return" component. Its purpose is to identify the structure of the parameter in the same component.

The error value is coded as shown in table 58.

The length of the error value is 1 octet.

**Table 58**

8	7	6	5	4	3	2	1	Octet
0	0	0	0	0	Error value			1

Error value (octet 1)

Bits	3	2	1	
	0	0	0	The parameter contains a "cause" information element
	all other values are reserved.			

NOTE: Other error values for specific PHI exception conditions are for further study.

## **Annex A (informative): Requirements on the common channel signalling system**

The common channel signalling system shall support the user-user signalling supplementary service (service 1) if switched Bd-channels or dynamically provisioned semi-permanent Bd-channels are used. In the signalling message during call establishment, less than 32 octets of "user-user" information are required.

## Annex B (informative): PHI signalling diagrams

### B.1 Introduction

#### B.1.1 Conventions for the diagrams

The diagrams indicate an advancing time from the top to the bottom without a fixed scale. The vertical lines indicate the positions of the relevant entities, i.e. (from left to right) the TE, the CRF-P and the PH. The vertical line for the CRF-S is split into two parallel lines, one for the Call Control (CC) and one for the Frame Handler (FH). Double lines indicate that an activity takes place, e.g. message creation or interpretation. Occasionally, a vertical line branches into two lines: this indicates that parallel processing is possible.

Messages between the TE and the CRF-S, the CRF-P and the PH, as well as messages in B-channels between the CRF-S and the CRF-P are shown with the following structure:

cc: ff(dd)[msg: ii1, ii2, .....] where the different elements are used to indicate the following:  
cc: the indication of the channel.  
ff: the HDLC frame designation.  
dd: the data link identifier (possibly structured into TEI and SAPI values).  
msg: the designation of a CCITT Recommendations Q.931 message type or an ITU-T Recommendation X.25 [4] call control packet.  
ii1, ii2,: indication of selected important information elements in the CCITT Recommendation Q.931 message.

Messages between the CRF-S and the CRF-P are only summarily indicated; they depend upon the actual common channel signalling system deployed.

The following abbreviations are used for the parameters and information elements:

#### Channel indication:

B1, B2: B-channel user access.  
D64: D-channel on PHI.  
D16: D-channel user access.  
Bbi: B-channel on PHI for B-channel service.  
Bdi: B-channel on PHI for D-channel service.  
Bds: B-channel on PHI for D-channel service with signalling data link.

#### Layer 2 address indication:

DLCI: for subscriber data link on Bd-channel  
SAPI = 16, LIC link specific.  
SDLCI: for signalling data link on Bd-channel  
SAPI = 0, LIC = 0.  
O, s: D-channel signalling link PHI  
SAPI = 0, TEI = 0.  
GTEI,s: broadcast on subscriber access  
SAPI = 0, TEI = 127.  
x,s: signalling link for specific TE  
SAPI = 0, TEI link specific.  
x,p: data link for specific TE  
SAPI = 16, TEI link specific.  
A: X.25 LAPB address/DCE.  
B: X.25 LAPB address/DTE.



**CCITT Recommendation Q.931 messages:**

CALLPROC	Call proceeding
CONN	Connect
CONNACK	Connect acknowledge
DISCONN	Disconnect
REG	Register
REL	Release
RELCOMP	Release complete
SETUP	Setup

**ITU-T Recommendation X.25 [4] Call control packets:**

X25CR	Call request
X25CC	Call connected
X25IC	Incoming call
X25CA	Call accepted
X25RST	Restart
X25RSC	Restart confirmation
X25CLR	Clear request
X25CLI	Clear indication
X25CLC	Clear confirmation

**ETS 300 403-1 [11] Information elements:**

Cg	Calling party number subclause 4.5.10
Cg = PH	Calling party number subclause 4.5.8
Cg = CRF-S	Calling party number subclause 4.5.8
CgS	Calling party subaddress subclause 4.5.11
Cd	Called party number subclause 4.5.8
Cd = PH	Called party number subclause 4.5.8 CCITT Recommendation E.164 [13] number of PH
Cd = CRF-S	Called party number subclause 4.5.8 CCITT Recommendation E.164 [13] number of CRF-S
CdS	Called party subaddress subclause 4.5.9
CI	Channel identification subclause 4.5.13
CI = anyB	Channel identification subclause 4.5.13 no channel indicated or preferred channel indicated
CI = B1,Bi	Channel indication subclause 4.5.13 exclusive B-channel, no D-channel
CI = Bbi	Channel identification subclause 4.5.13 excl. B-channel, for B-channel service
CI = Bdi	Channel identification subclause 4.5.13 excl. B-channel, for D-channel service
CI = D	Channel identification subclause 4.5.13 D-channel, no B-channel
CI = B1/D	Channel identification subclause 4.5.13 exclusive B-channel and D-channel
BC	Bearer capability subclause 4.5.5
BC = 64	Bearer capability subclause 4.5.5 64 kbit/s unrestricted
BC = Pk	Bearer capability subclause 4.5.5 packet mode
Cs = 7	Cause (value 7) subclause 4.5.12 call awarded, delivered in established channel
Cs = 102	Cause (value 102) subclause 4.5.12 recovery on timer expiry
UU = (..)	User-user subclause 4.5.29 with parameter indication

**User-user information element fields:**

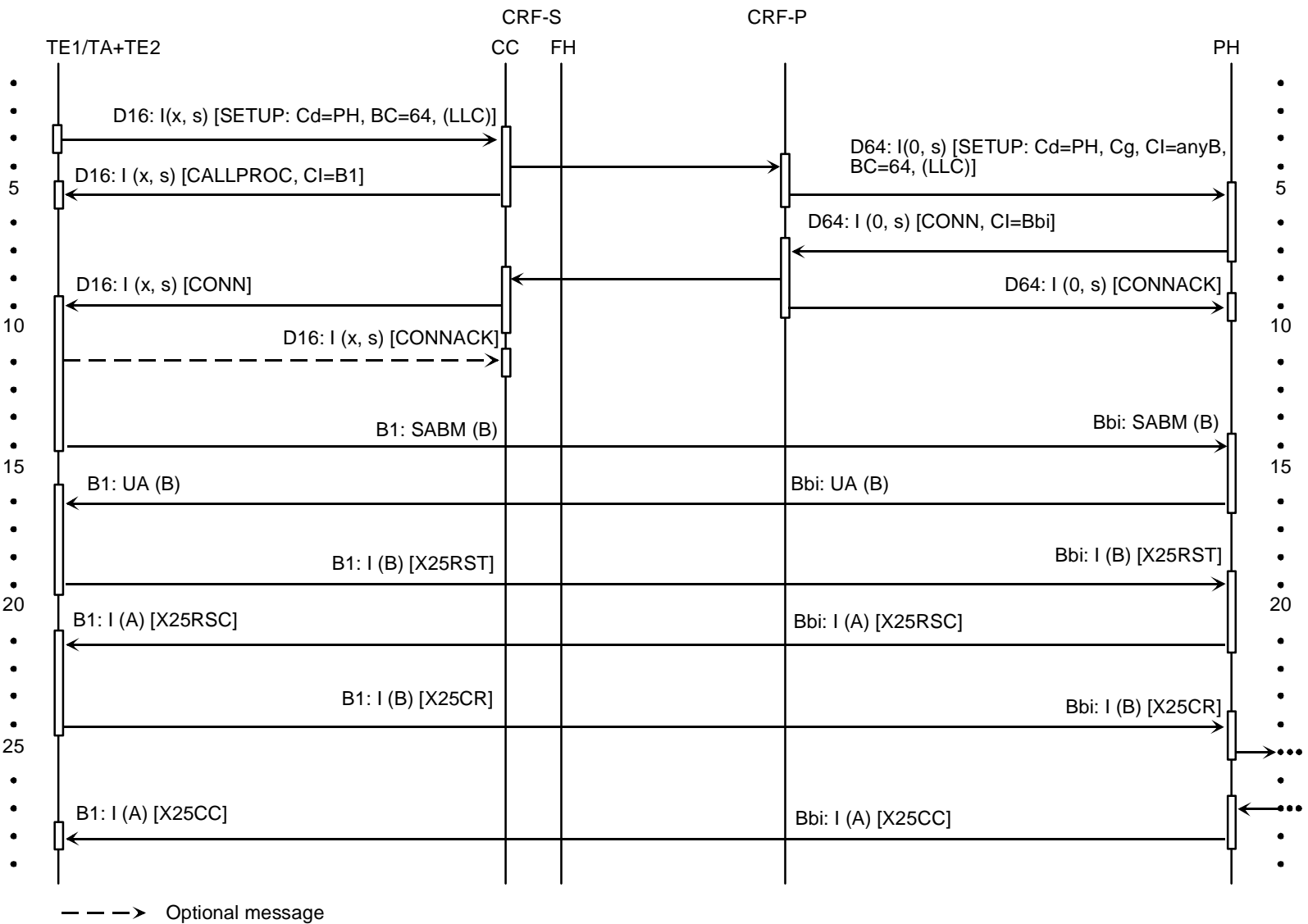
semi	semi-permanent registration. Bd-channel: THPI not activated
DCLI	DCLI value present
ref	Bd-channel reference present
sbr	FH reference number present
ASI	additional subscriber identification
Cd	"Called party number" present

**Facility information elements:**

inv	invoke component
PLL	PLL registration
semi	semi-permanent registration
dereg	deregistration
res	result component
res = ()	empty result component

**B.2 B-channel services case A**

**B.2.1 B-channel establishment**



**Figure B.1: case A, outgoing call. No B-channel between the TE and the PH exists yet. Signalling in the common signalling channel**

B.2.2 B-channel disconnection

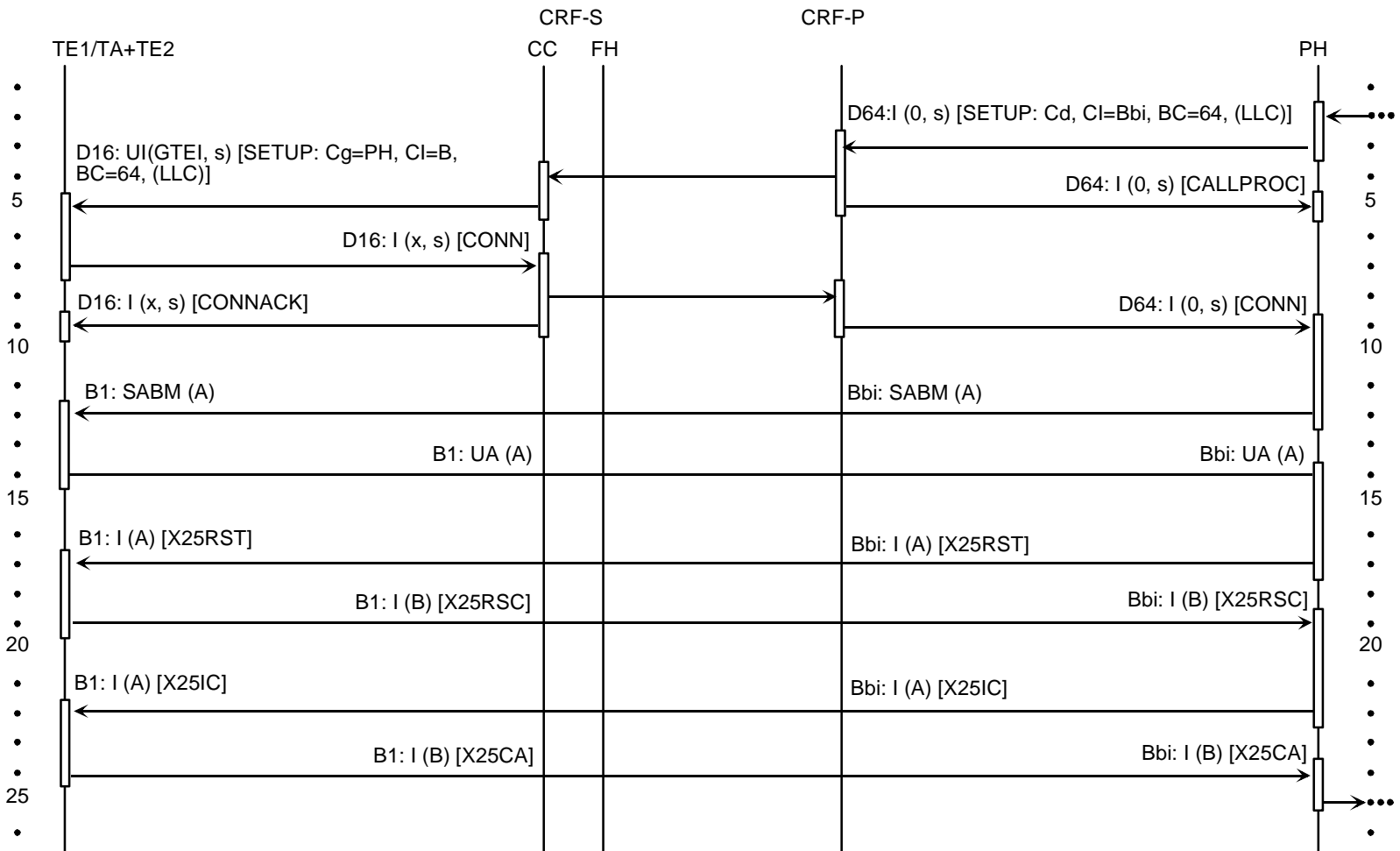
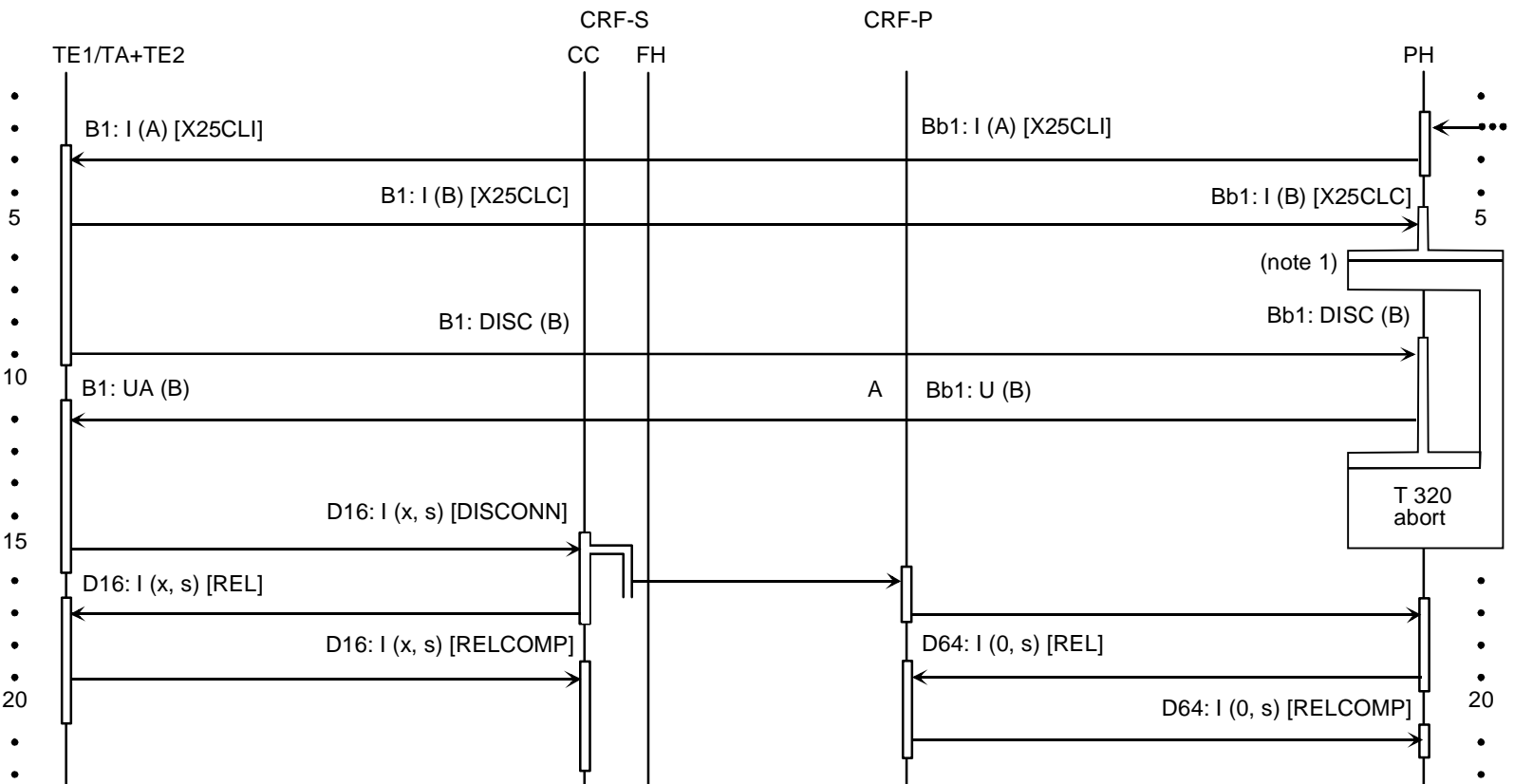
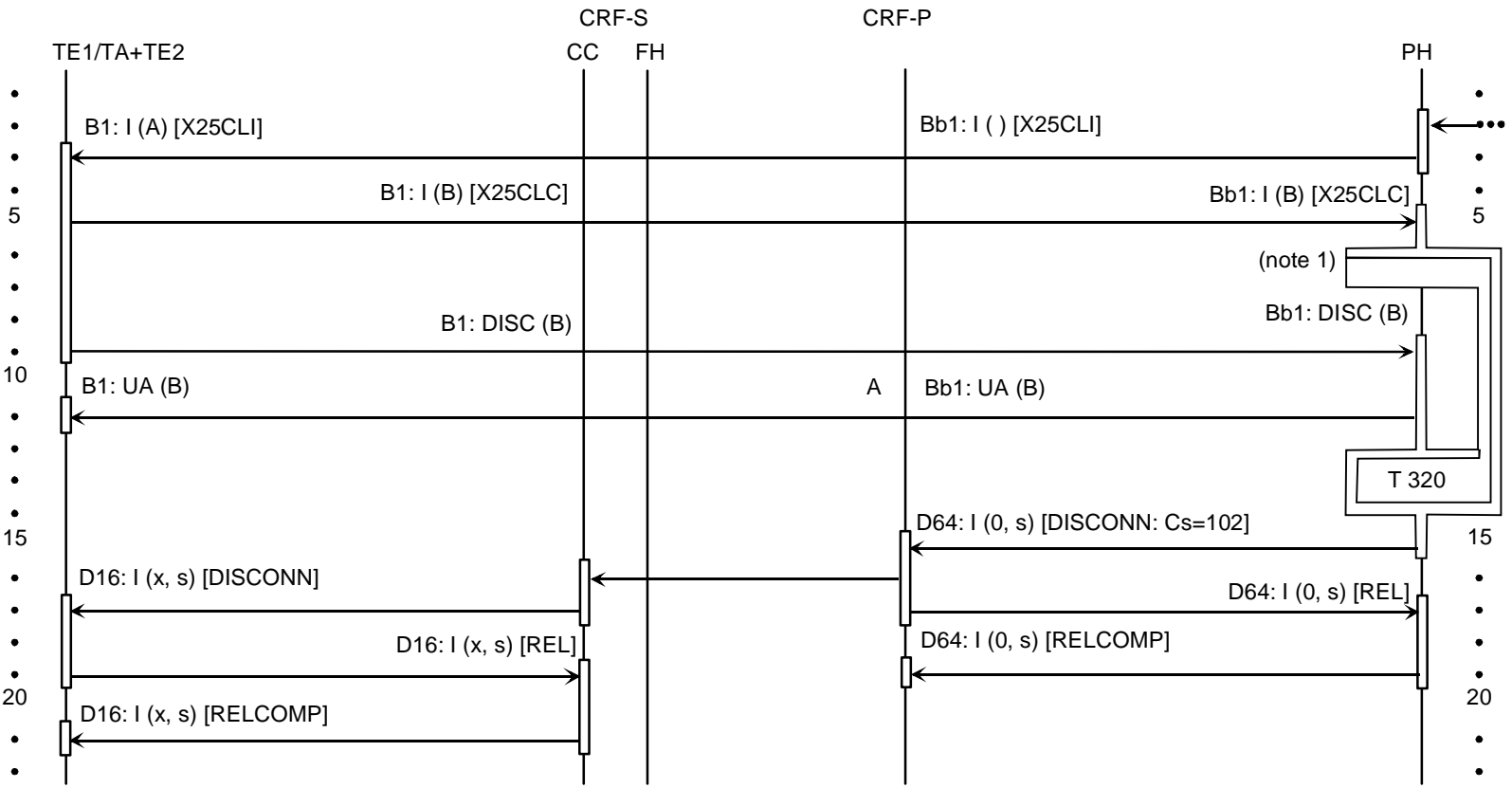


Figure B.2: case A, incoming call.  
 No B-channel between the PH and the TE exists yet. Signalling in the common signalling channel



NOTE 1: From here on, the diagram is the same, regardless of whether the last virtual circuit has been cleared by the PH or the TE.

Figure B.3: Link disconnected by TE.  
B-channel released by TE. Signalling in the common signalling channel

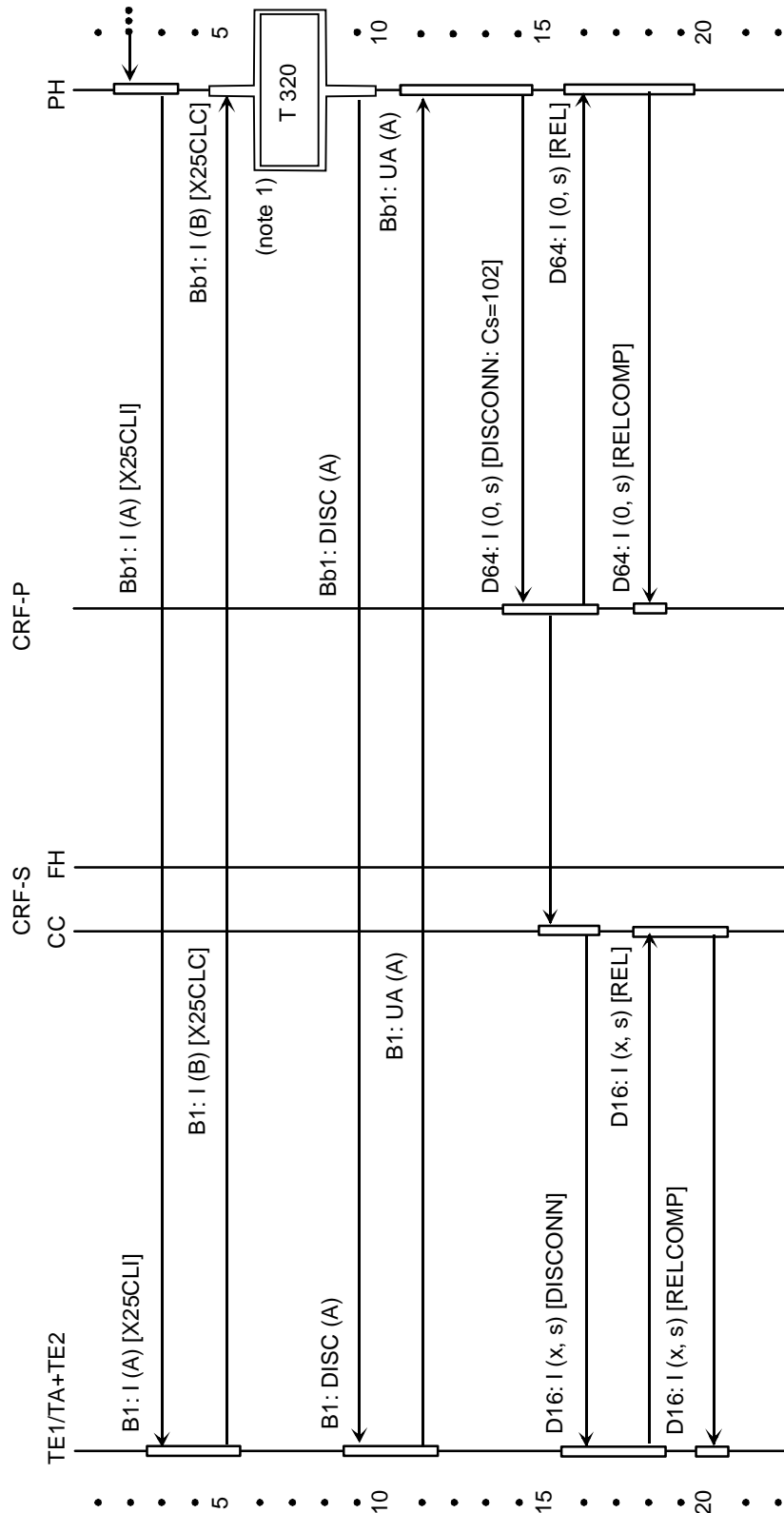


NOTE 1: From here on, the diagram is the same, regardless of whether the last virtual circuit has been cleared by the PH or the TE.

Figure B.4: Link disconnected by TE.  
 B-channel released by PH after expiry of T320. Signalling in the common signalling channel

### B.3 B-channel services case B

#### B.3.1 B-channel establishment



NOTE 1: From here on the diagram is the same, regardless of whether the last virtual circuit has been cleared by the PH or the TE.

**Figure B.5: Link disconnected by PH after expiry of T320.  
 B-channel released by PH. Signalling in the common signalling channel**

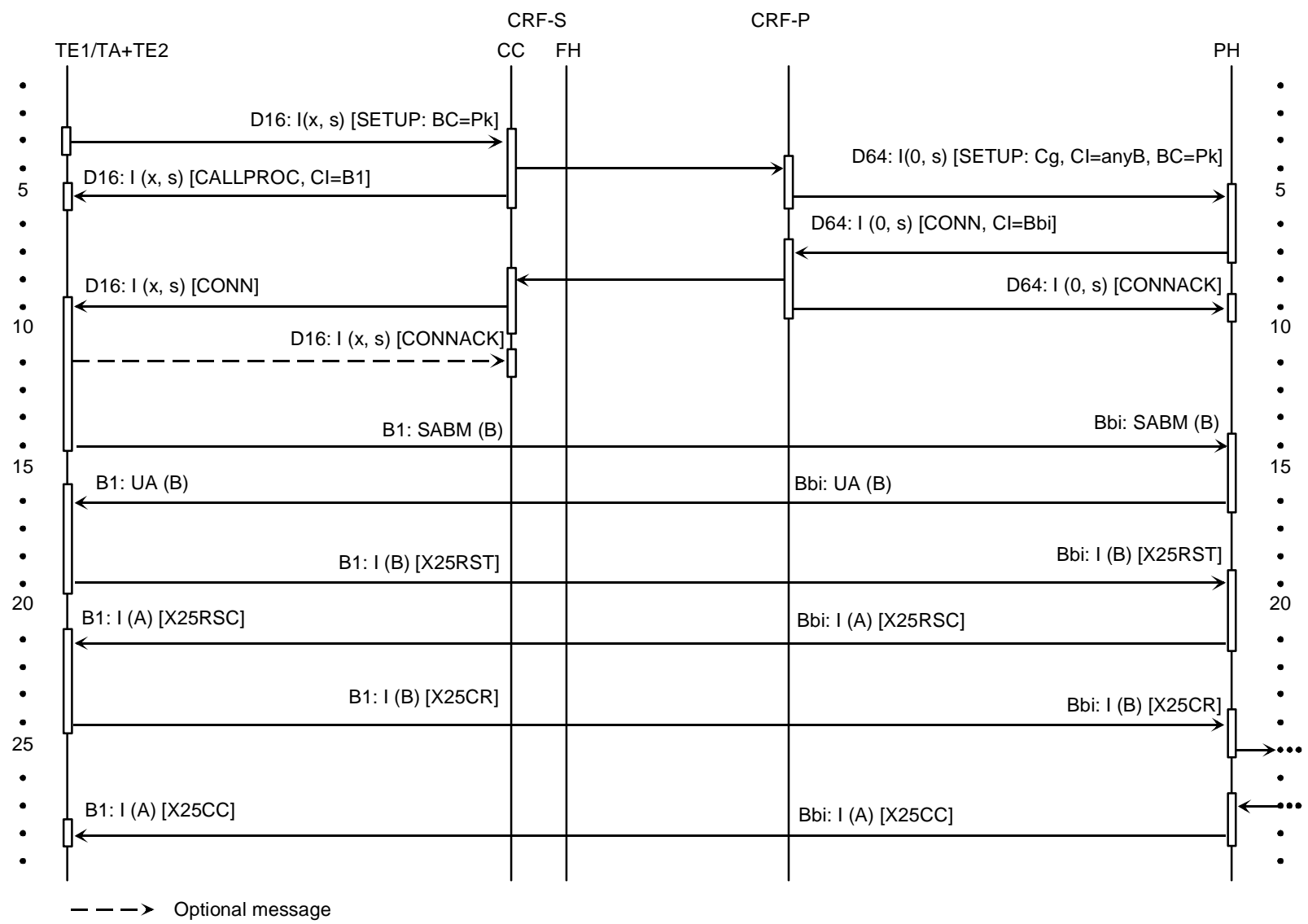


Figure B.6: case B, outgoing call.  
 No B-channel between the TE and the PH exists yet. Signalling in the common signalling channel



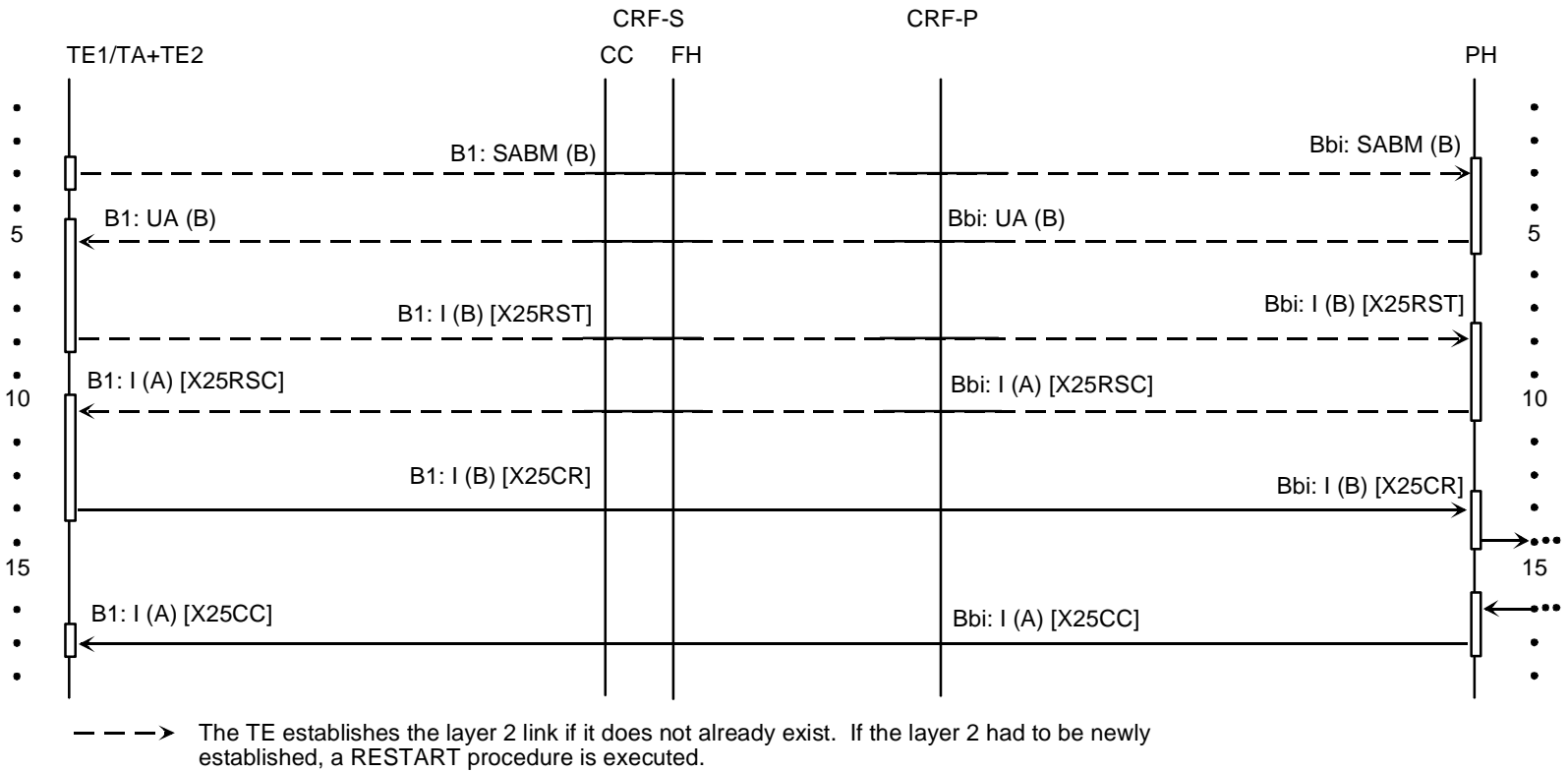


Figure B.7: case B, outgoing call.  
 A-B-channel between the TE and the PH exists already. No signalling

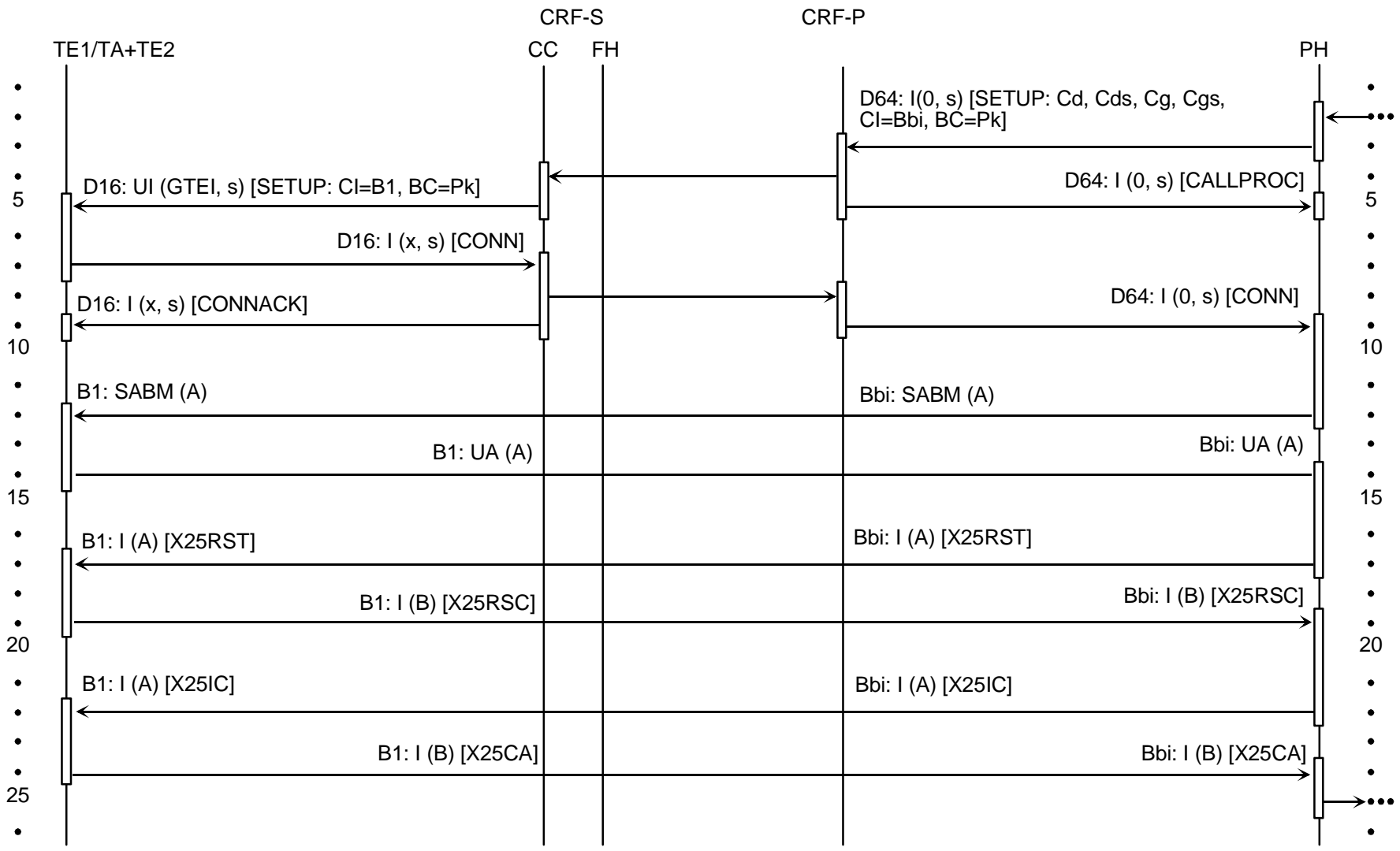


Figure B.8: case B. Incoming call.  
 No B-channel between the PH and the TE exists yet. Signalling in the common signalling

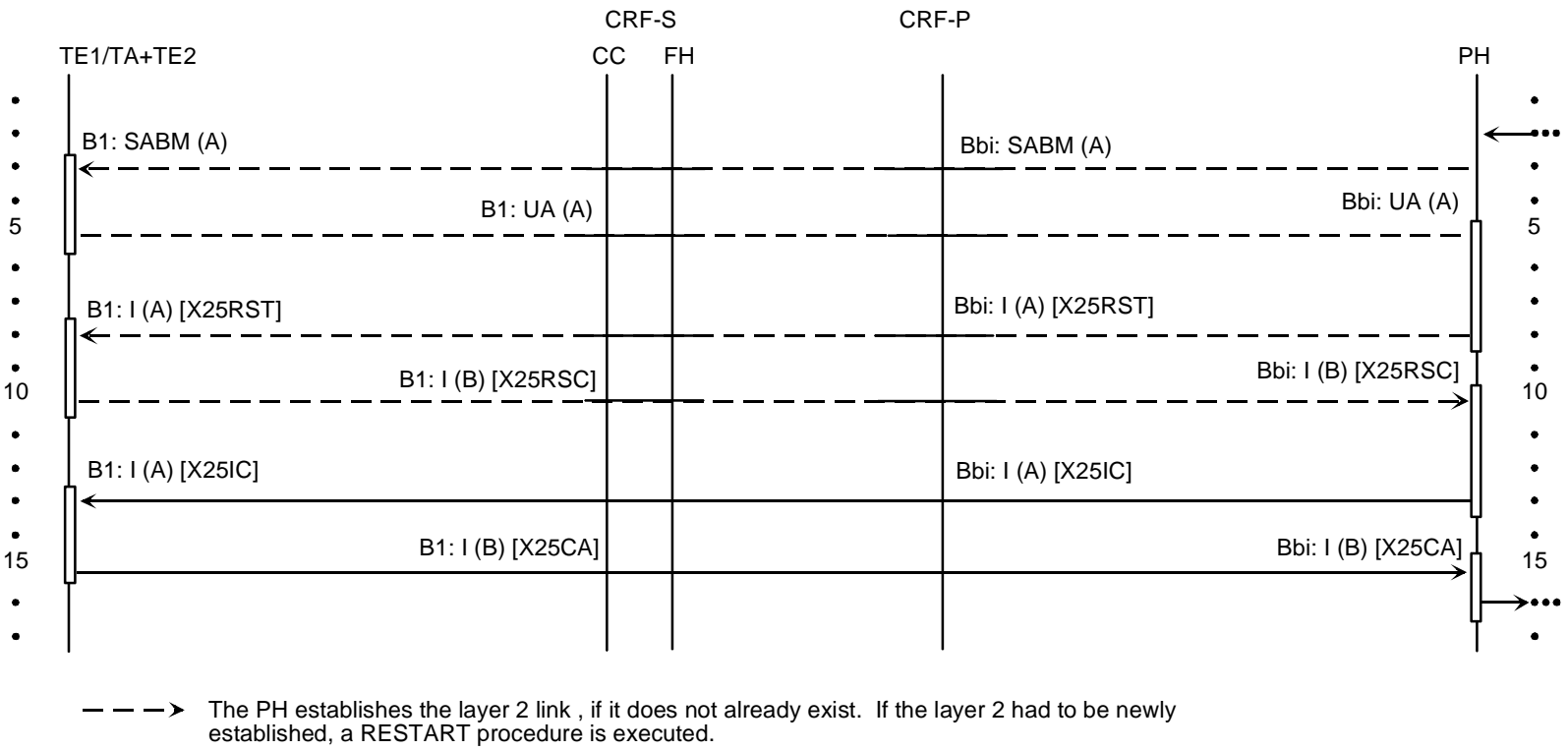
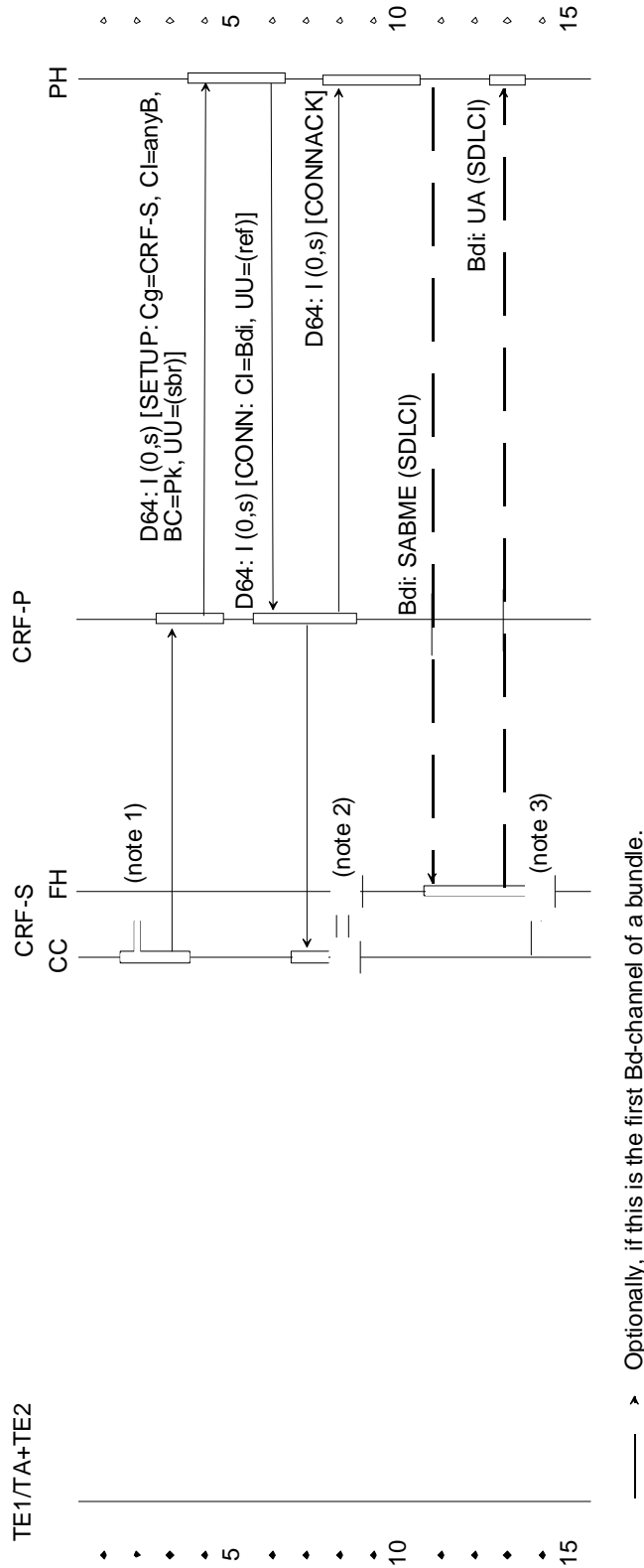


Figure B.9: case B, incoming call.  
 A B-channel between the PH and the TE exists already. No signalling  
 or  
 Case B, incoming call, semi-permanent. No signalling

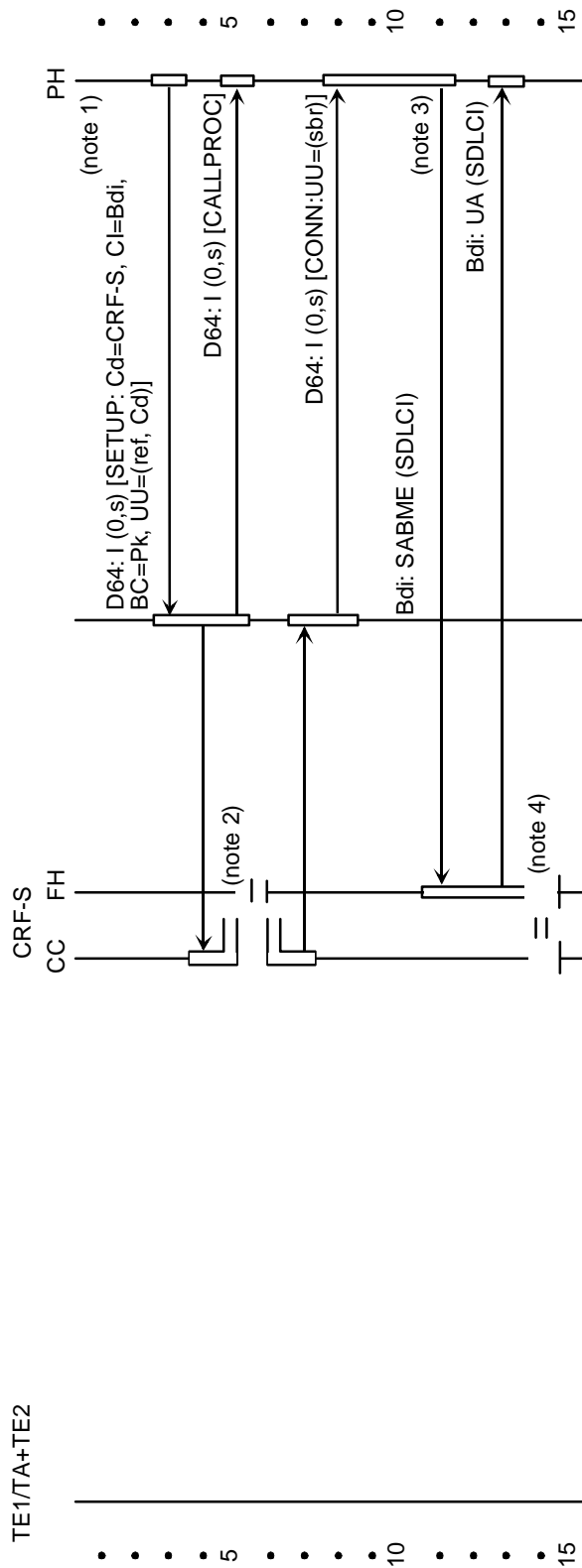
## B.4 Dynamic Bd-channels

### B.4.1 Bd-channel establishment



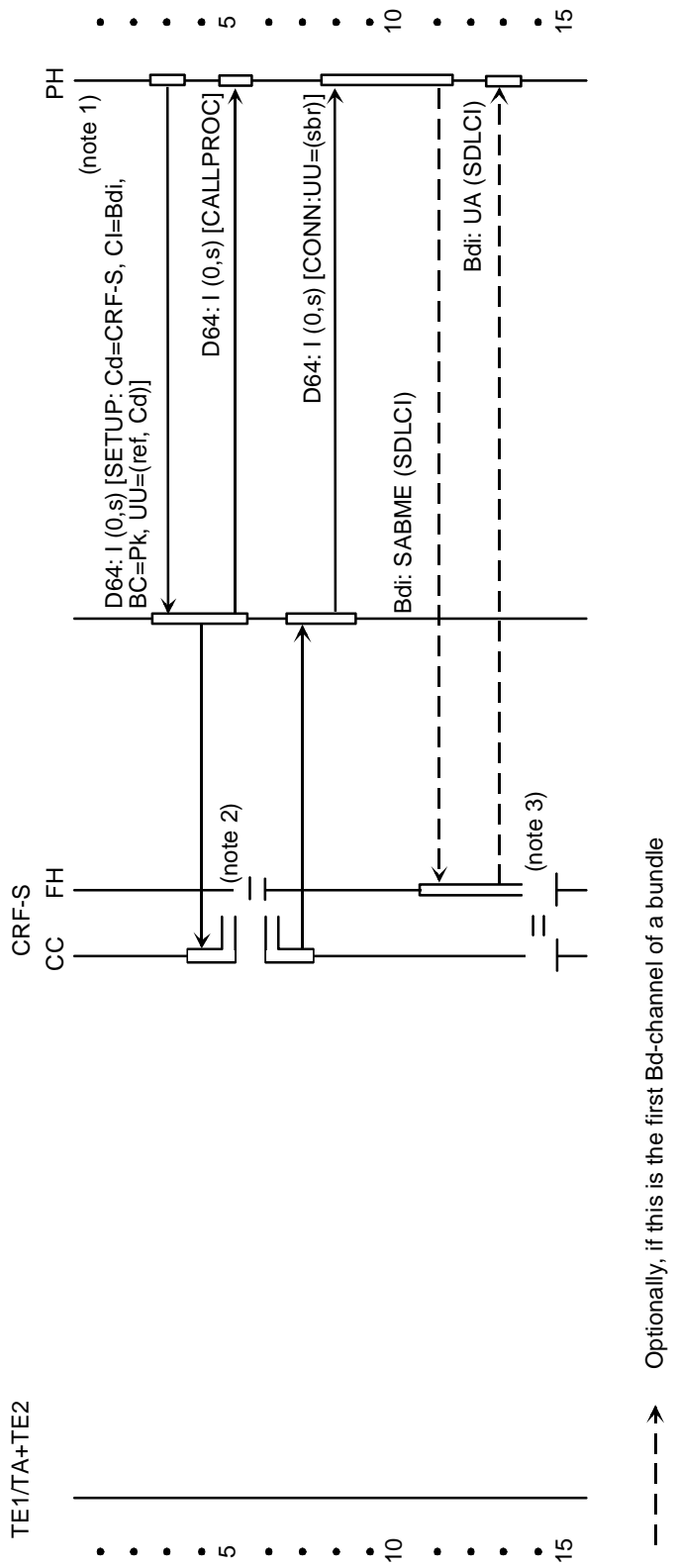
- NOTE 1: The request to establish a new Bd-channel might stem from either the FH or the CC.  
 NOTE 2: The FH is informed about the establishment of the Bd-channel.  
 NOTE 3: CC is informed that the establishment of the new Bd-channel is complete.

**Figure B.10: Bd-channel establishment by the CRF-S.**  
 No Bd-channel between the FH and the PH exists yet. Signalling in the common signalling channel



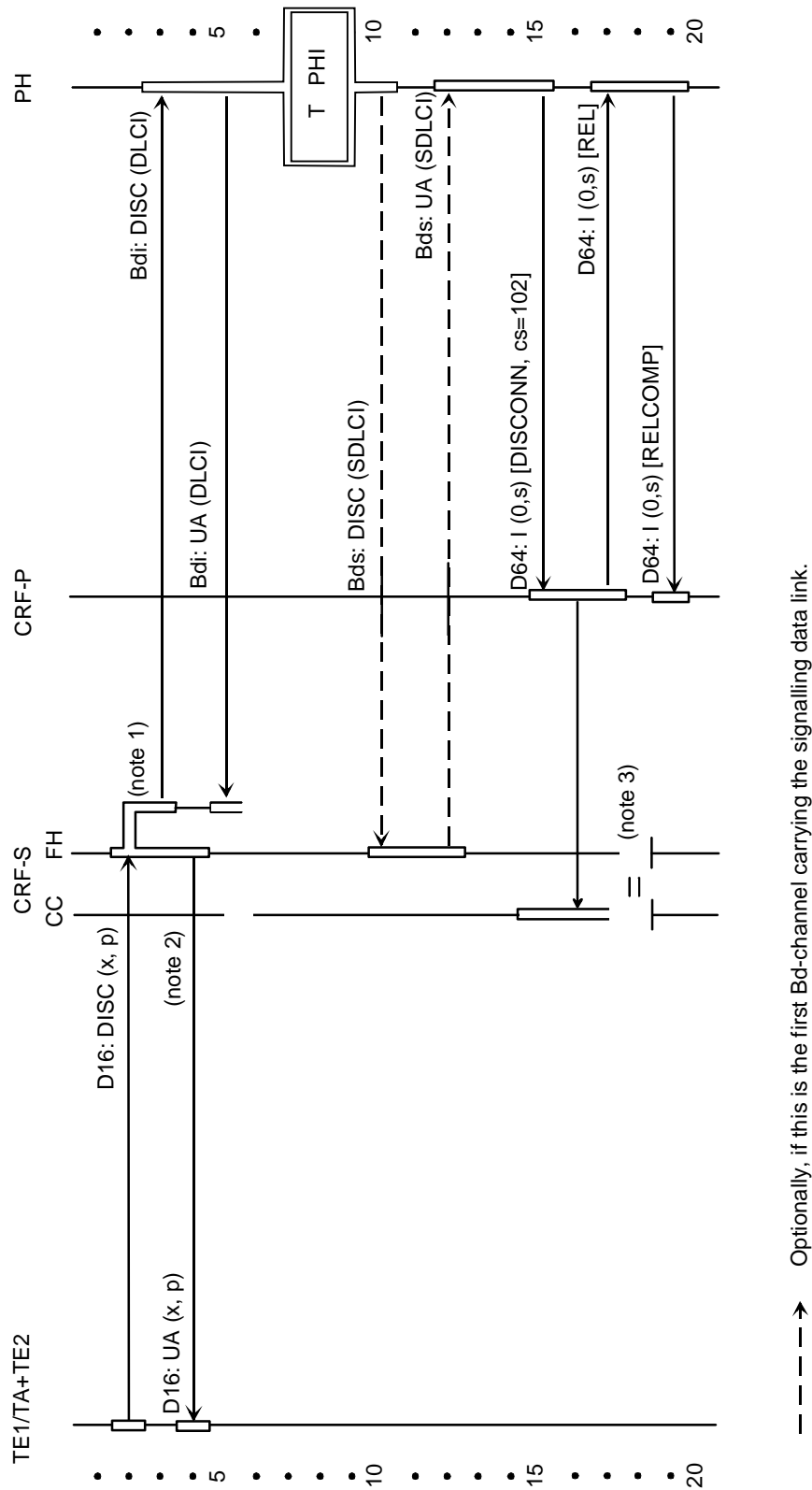
- NOTE 1: The establishment of a Bd-channel using the called party number in the "user-user" information element is instigated by the receipt of an incoming ITU-T Recommendation X.25 "call request" packet.
- NOTE 2: The FH is informed about the establishment of the Bd-channel.
- NOTE 3: This is the first Bd-channel of a bundle, therefore a signalling link shall be established.
- NOTE 4: CC is informed that the establishment of the new Bd-channel is complete.

**Figure B.11: Bd-channel establishment by the PH. No Bd-channel between the CRF-S and the PH exists yet. Signalling in the common signalling channel**



- NOTE 1: The establishment of a Bd-channel using the FH reference number in the "user-user" information element is instigated by either the receipt of an incoming ITU-T Recommendation X.25 "call request" packet for a PLL service, or through traffic load considerations by the PH.
- NOTE 2: The FH is informed about the establishment of the Bd-channel.
- NOTE 3: CC is informed that the establishment of the new Bd-channel is complete.

**Figure B.12: Bd-channel establishment by the PH.**  
**No Bd-channel between the FH and the PH exists yet**  
 or  
**A new Bd-channel is required due to traffic load.**  
**Signaling in the common signalling channel**

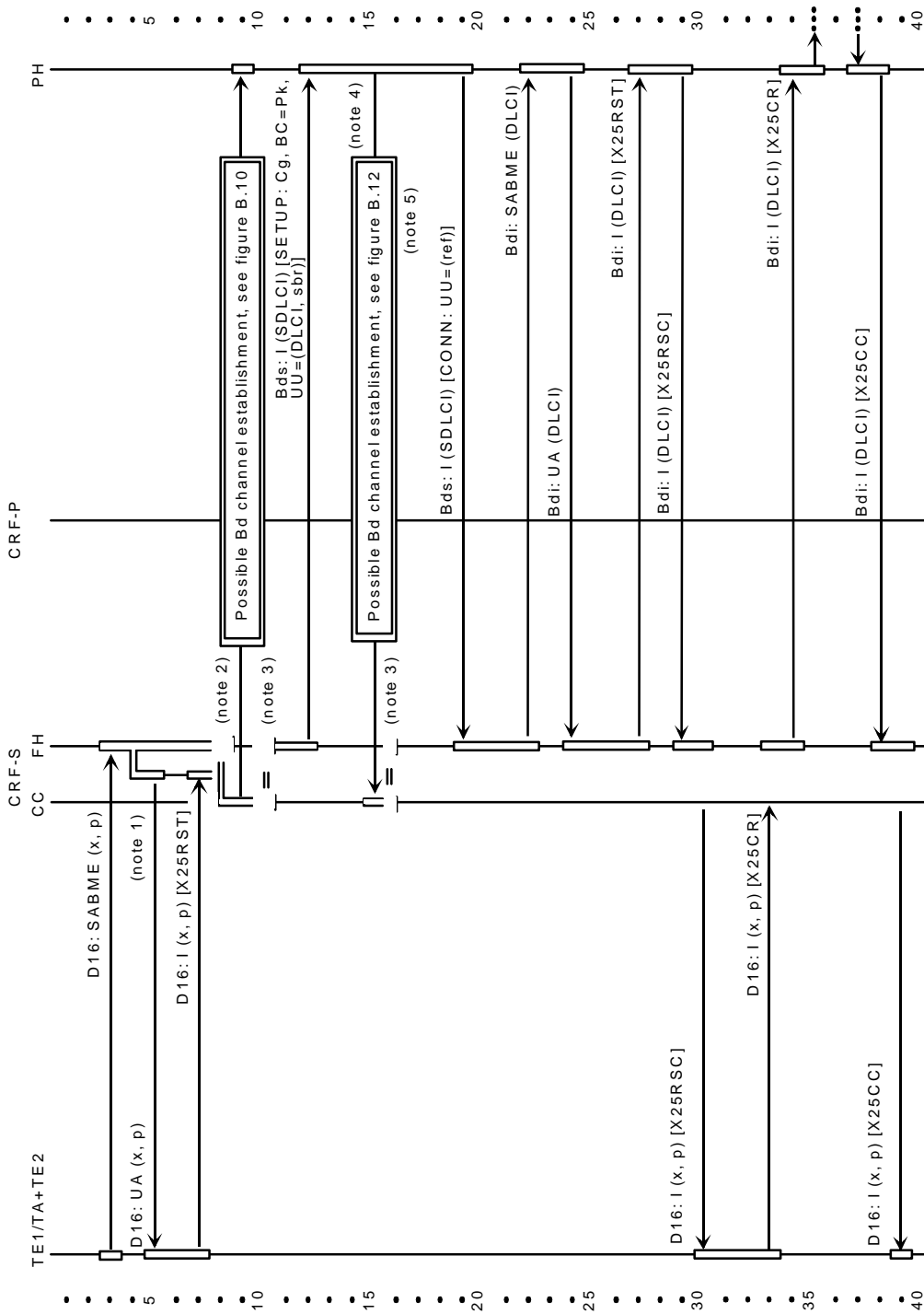


- NOTE 1: The last data link could have been disconnected also from the PH side.  
 NOTE 2: depending on the particular implementation, the layer 2 sequences at the subscriber access might be different from the ones shown in the diagram.  
 NOTE 3: The FH is informed that the Bd-channel is disconnected.

**Figure B.13: Last data link disconnected.  
 Bd-channel released by PH after T PHI**

## B.5 Data link establishment and release

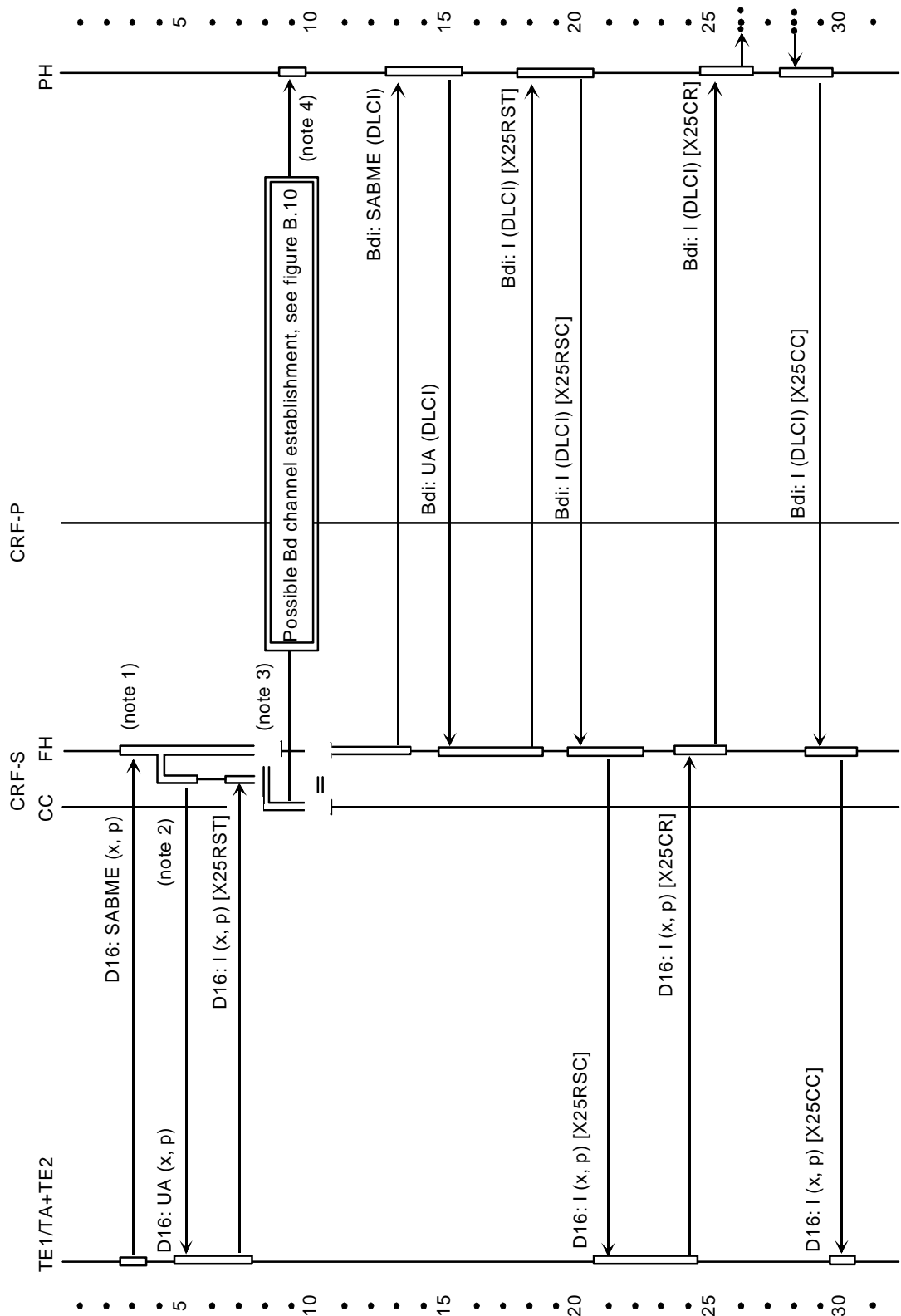
### B.5.1 D-channel data link establishment



- NOTE 1: Depending on the particular implementation, the layer 2 sequences at the subscriber access might be different from the ones shown in the diagram.
- NOTE 2: If no Bd-channel exists, i.e. no signalling data link exists, the CRF-S establishes one.
- NOTE 3: The FH is informed about the establishment of a new Bd-channel.
- NOTE 4: If no Bd-channel in the particular sub-bundle exists, or the traffic load suggests the requirement for a new Bd-channel, the PH establishes one.
- NOTE 5: If the FH implements a frame switching technique, this message is RELEASE COMPLETE.

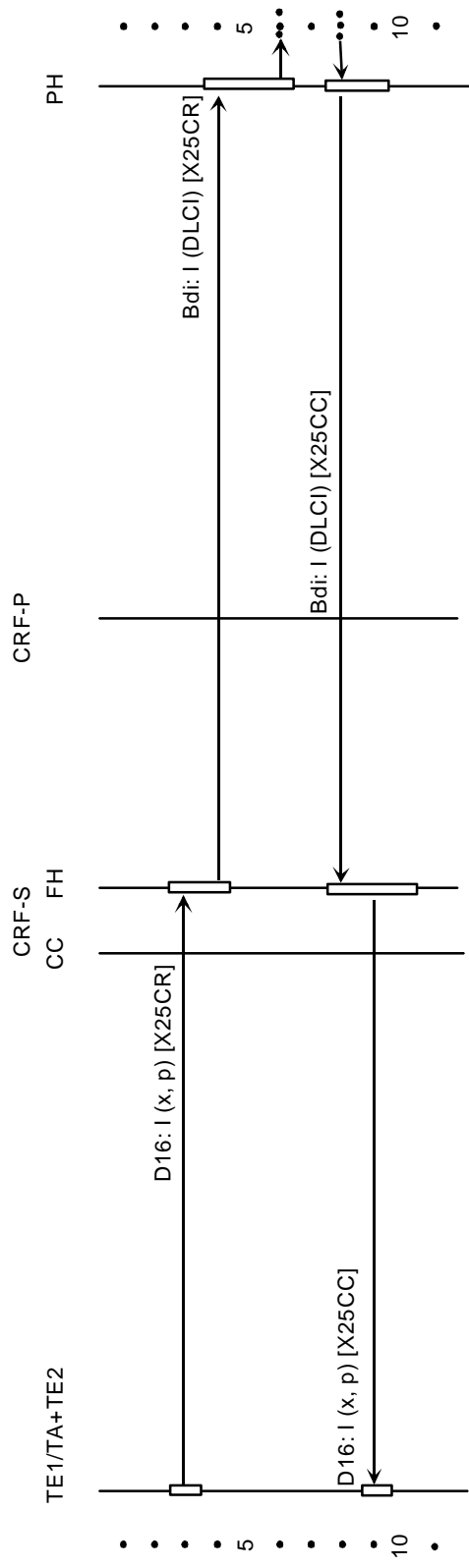
Figure B.14: Outgoing call, on demand D-channel signalling in the Bd-channel



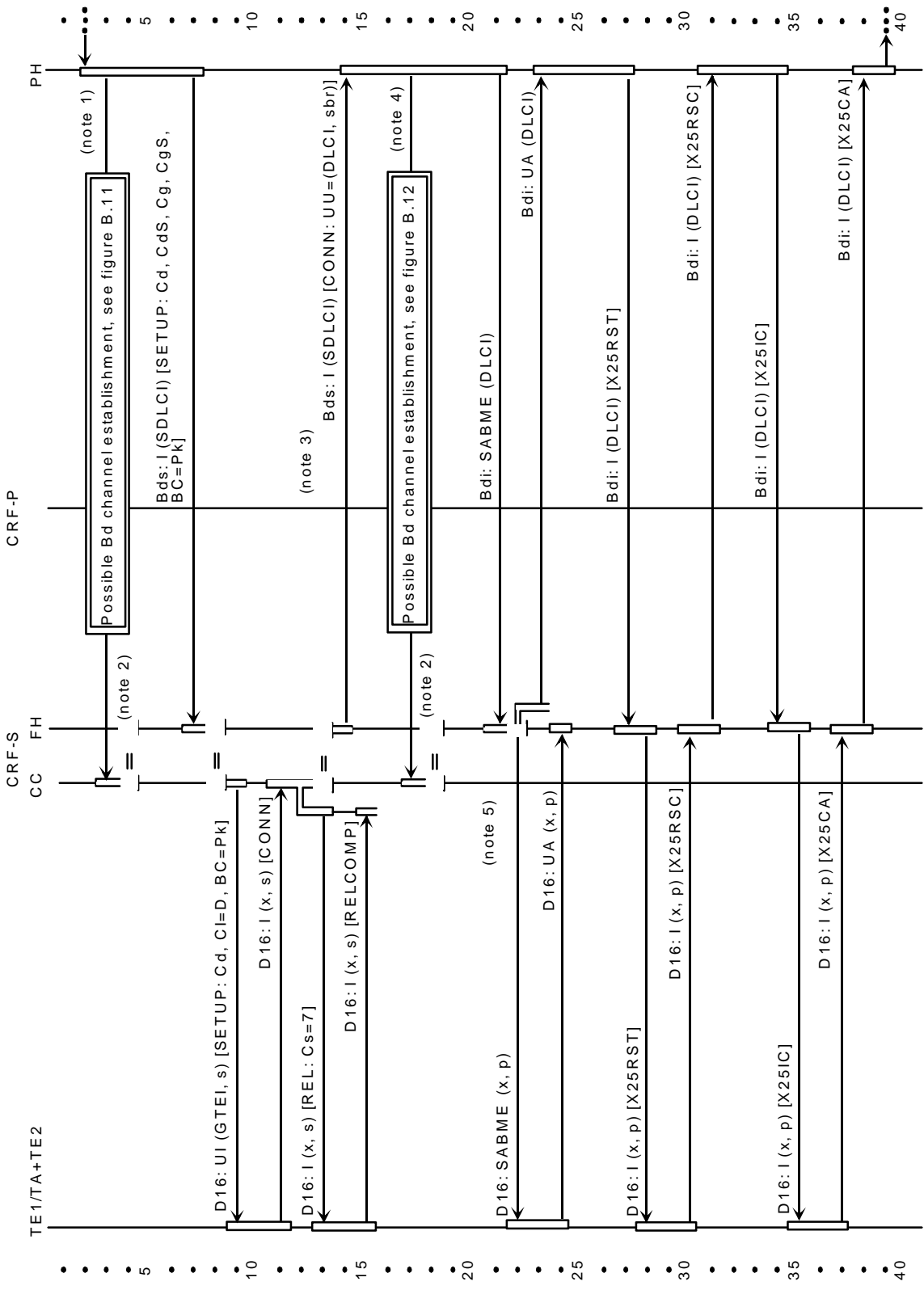


- NOTE 1: The mapping of the DLCI value to the TEI is known by the CRF-S, therefore the TEI value "x" shall be manually assigned.
- NOTE 2: Depending on the particular implementation, the layer 2 sequences at the subscriber access may be different from the ones shown in the diagram.
- NOTE 3: If no Bd-channel in the particular sub-bundle (or in the whole bundle) exists, the CRF-S establishes one.
- NOTE 4: The PH knows the mapping of the calling address to the DLCI value.

Figure B.15: Outgoing call, PLL no signalling

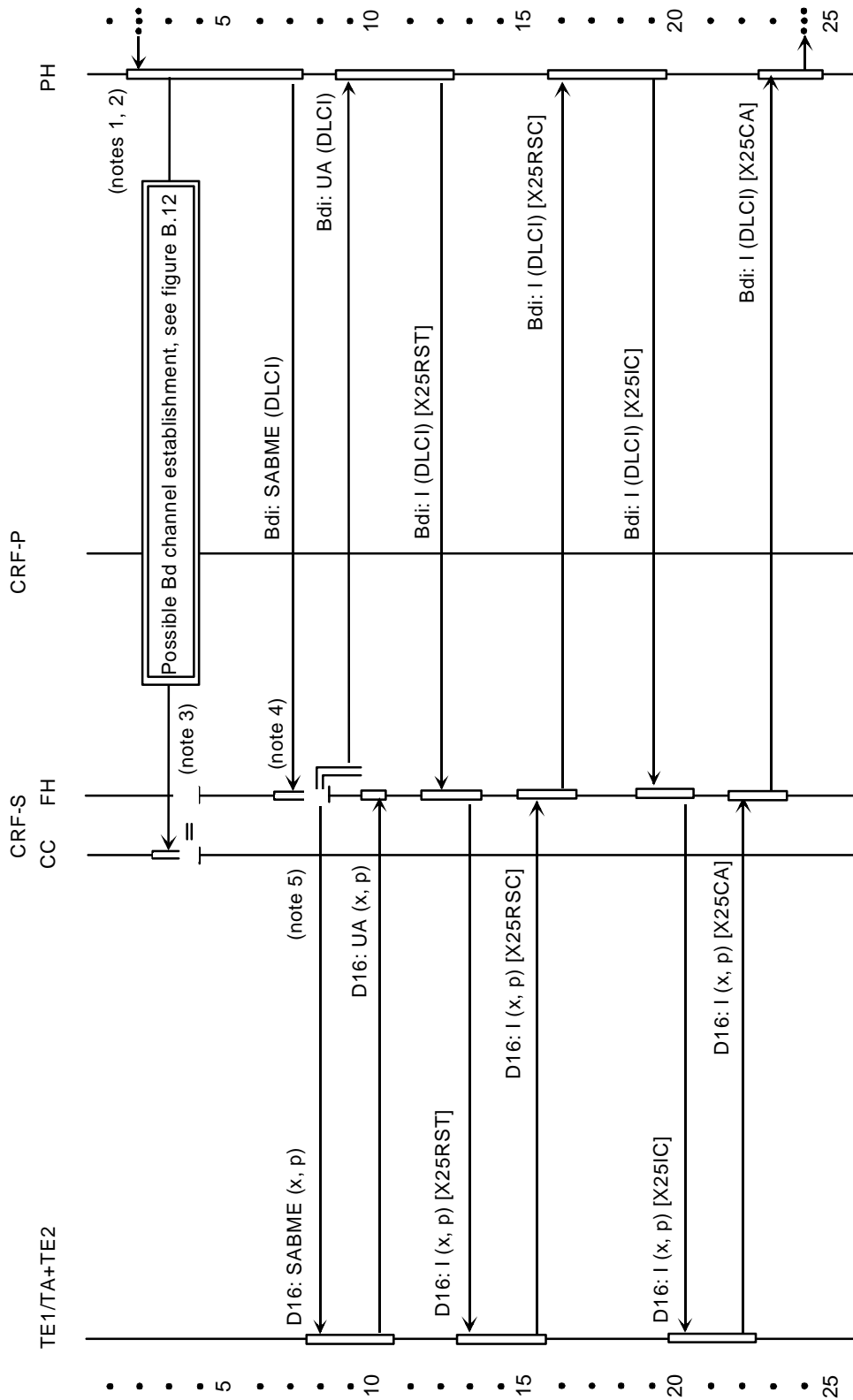


**Figure B.16: Outgoing call, PLL.**  
 A data link between the FH and the PH exists already. No signalling



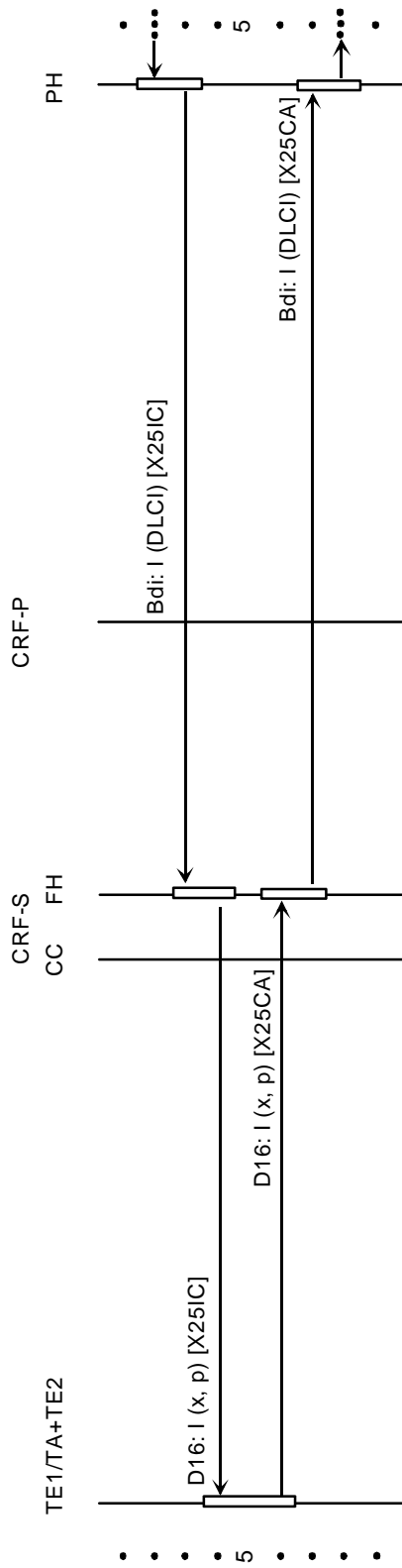
- NOTE 1: If no Bd-channel exists, i.e. no signalling data link exists, the PH establishes one.  
 NOTE 2: The FH is informed about the establishment of a new Bd-channel.  
 NOTE 3: If the FH implements a frame switching technique, this message is RELEASE COMPLETE.  
 NOTE 4: If no Bd-channel in the particular sub-bundle exists or the traffic load suggests the requirement for a new Bd-channel, the PH establishes one.  
 NOTE 5: Depending on the particular implementation, the layer 2 sequences at the subscriber access might be different from the ones shown in the diagram.

Figure B.17: Incoming call, on demand signalling in the Bd-channel



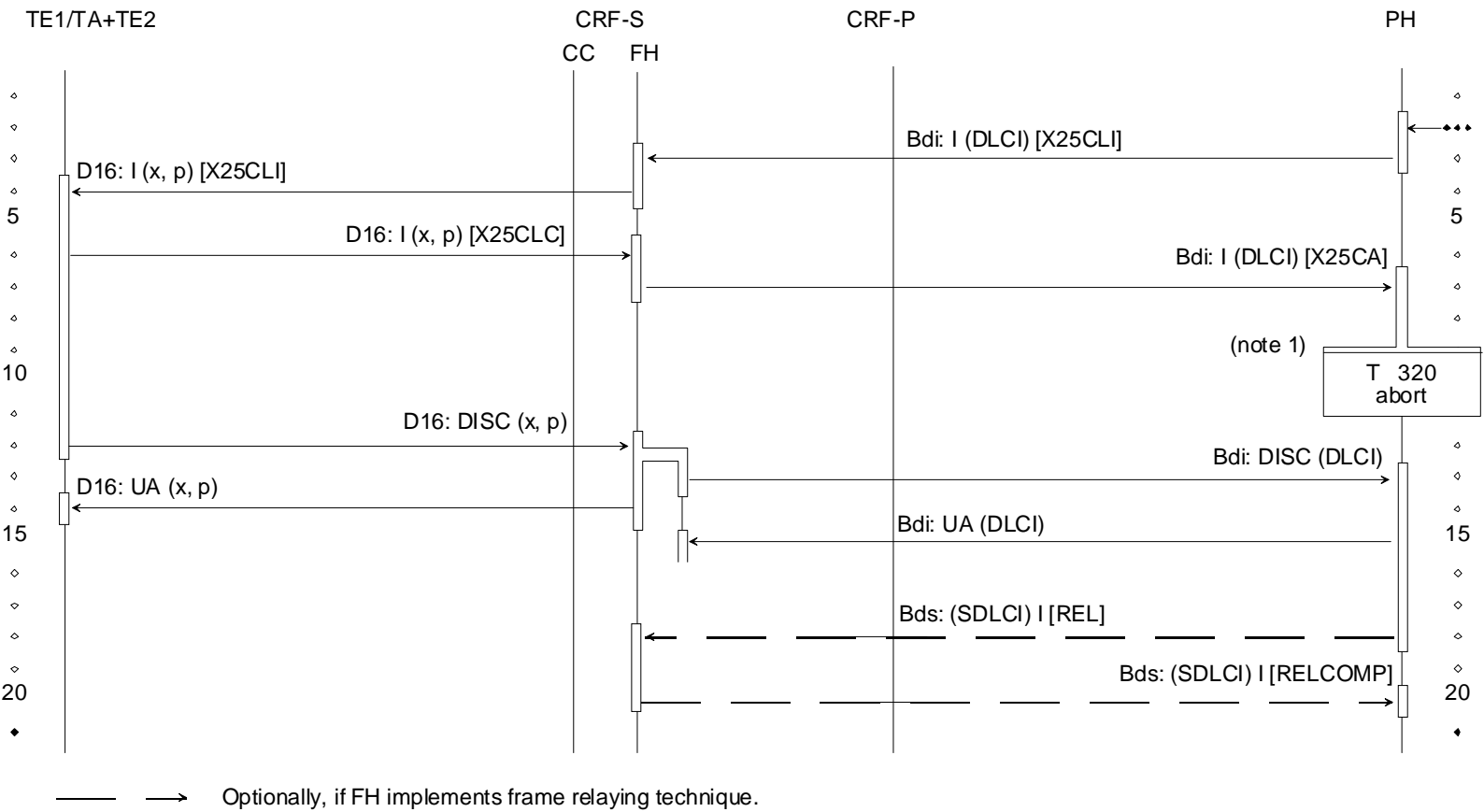
- NOTE 1: The PH knows the mapping of the called address to the DLCI value and the subbundle.
- NOTE 2: If no Bd-channel in the particular sub-bundle exists, or the traffic load suggests the requirement for a new Bd-channel, the PH establishes one.
- NOTE 3: The FH is informed about the establishment of a new Bd-channel.
- NOTE 4: The mapping of the DLCI value to the TEI is known by the CRF-S, therefore the TEI value "x" shall be manually assigned.
- NOTE 5: Depending on the particular implementation, the layer 2 sequences at the subscriber access might be different from the ones shown in the diagram.

**Figure B.18: Incoming call, PLL.  
 No signalling**



**Figure B.19: Incoming call, PLL.**  
 A data link between the PH and the TE exists already. No signalling

B.5.2 D-channel link disconnection

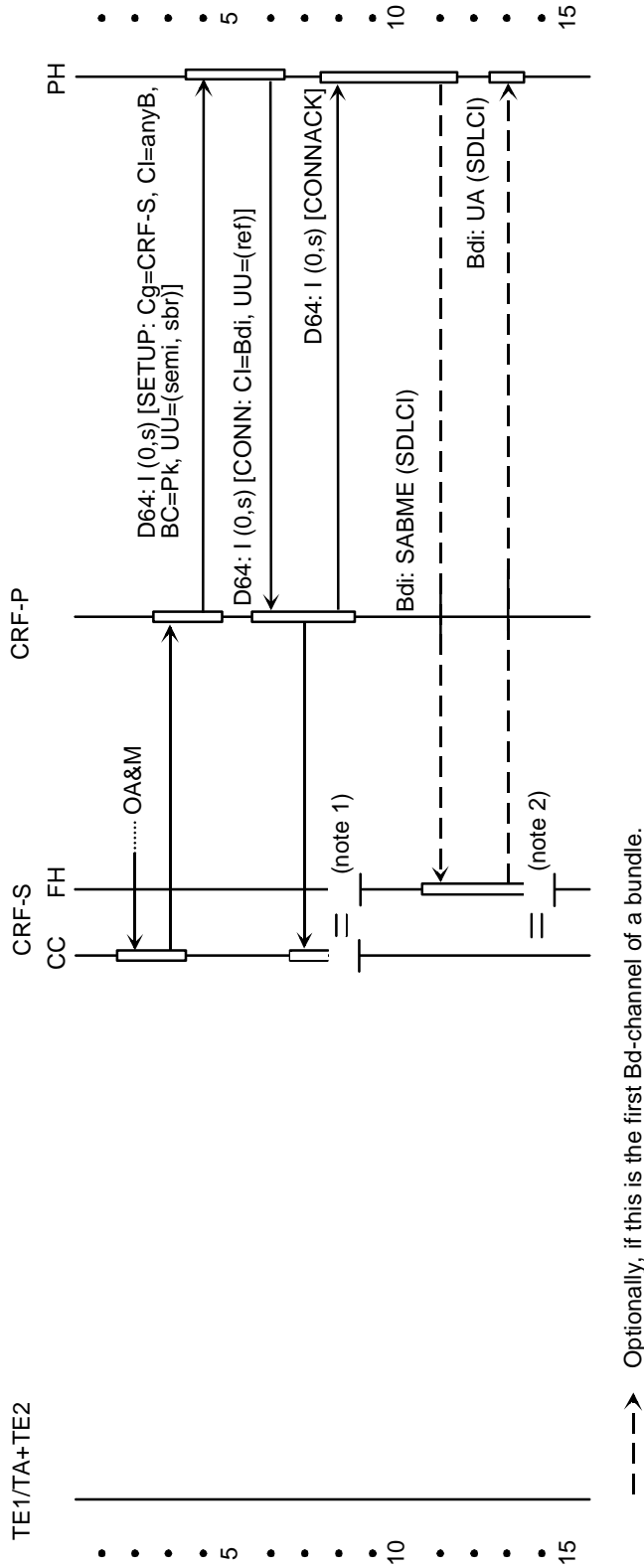


NOTE 1: From here on the diagram is the same regardless of whether the last virtual circuit has been cleared by the PH or the TE.

Figure B.20: Link disconnected by TE. FH implements frame switching technique. No signalling



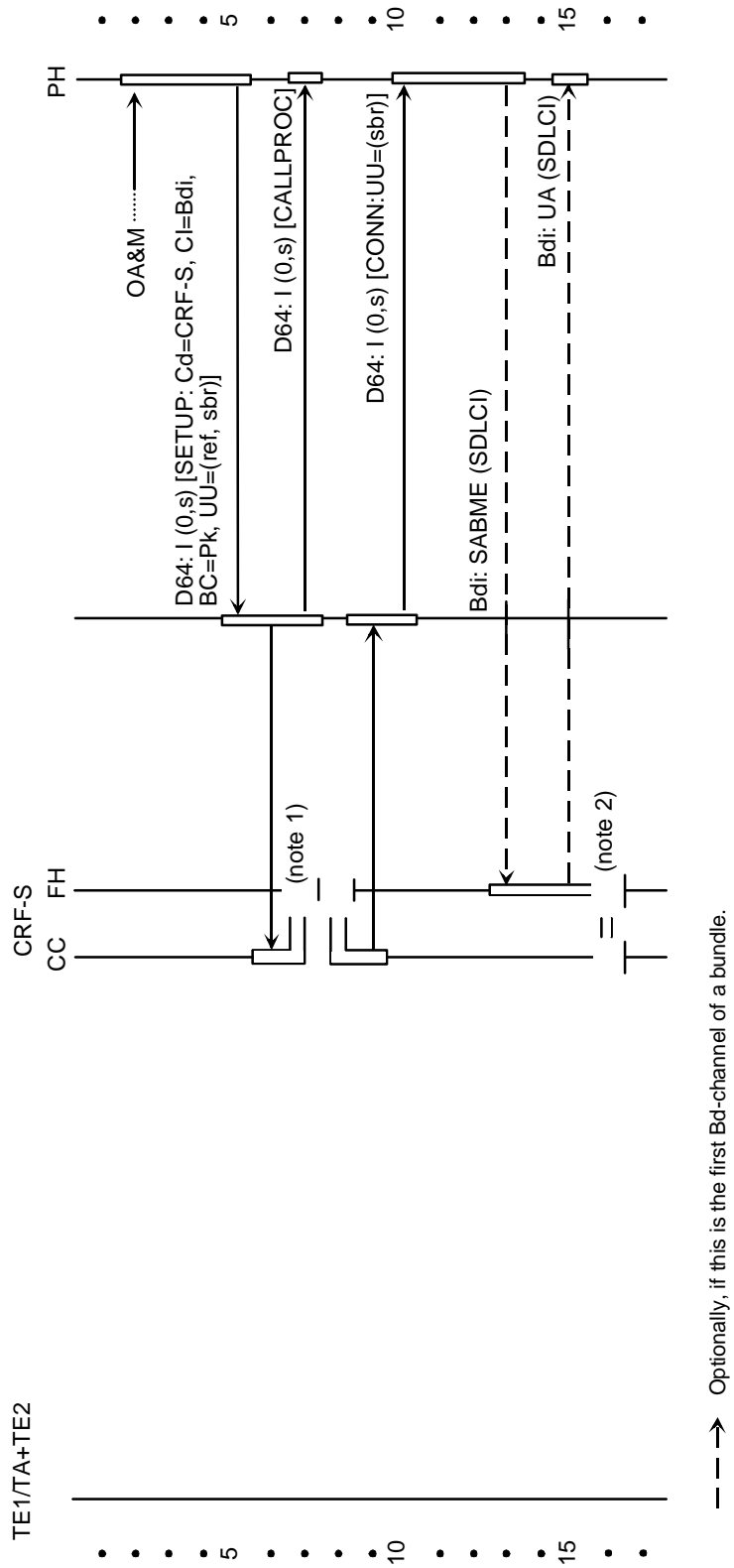
**B.6 Bd-channel establishment, semipermanent**



NOTE 1: The FH is informed about the establishment of the Bd-channel.  
 NOTE 2: CC is informed that the establishment of the new Bd-channel is complete.

**Figure B.22: Bd-channel establishment by the CRF-S. Signalling in the common signalling-channel**



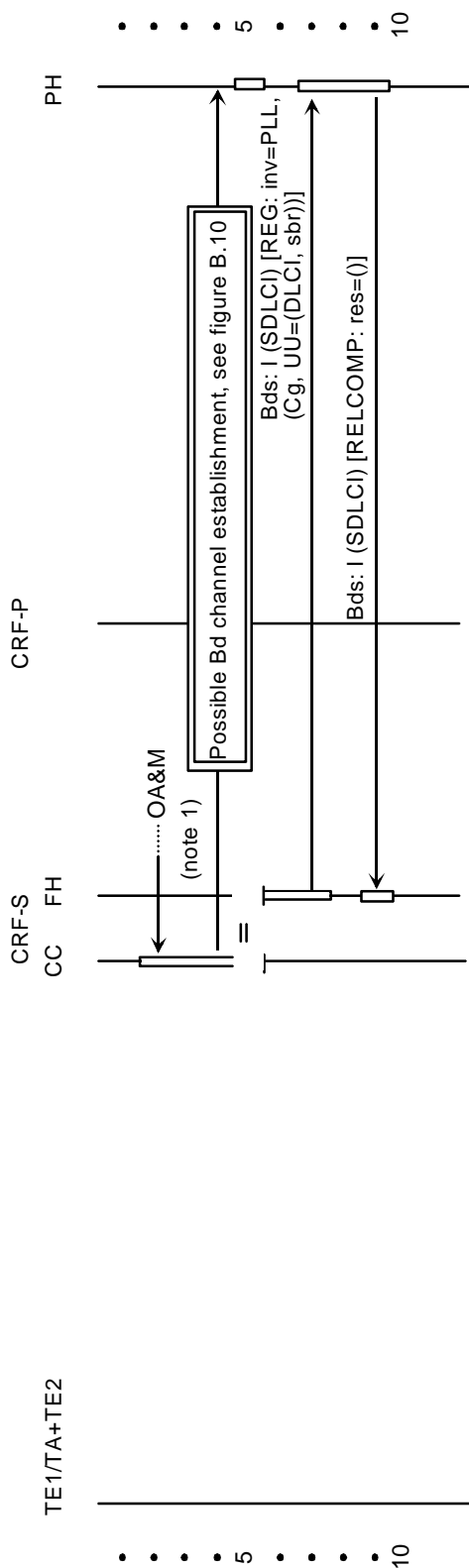


NOTE 1: The FH is informed about the establishment of the Bd-channel.  
 NOTE 2: CC is informed that the establishment of the new Bd-channel is complete.

**Figure B.23: Bd-channel establishment by the PH.  
 Signalling in the common signalling channel**

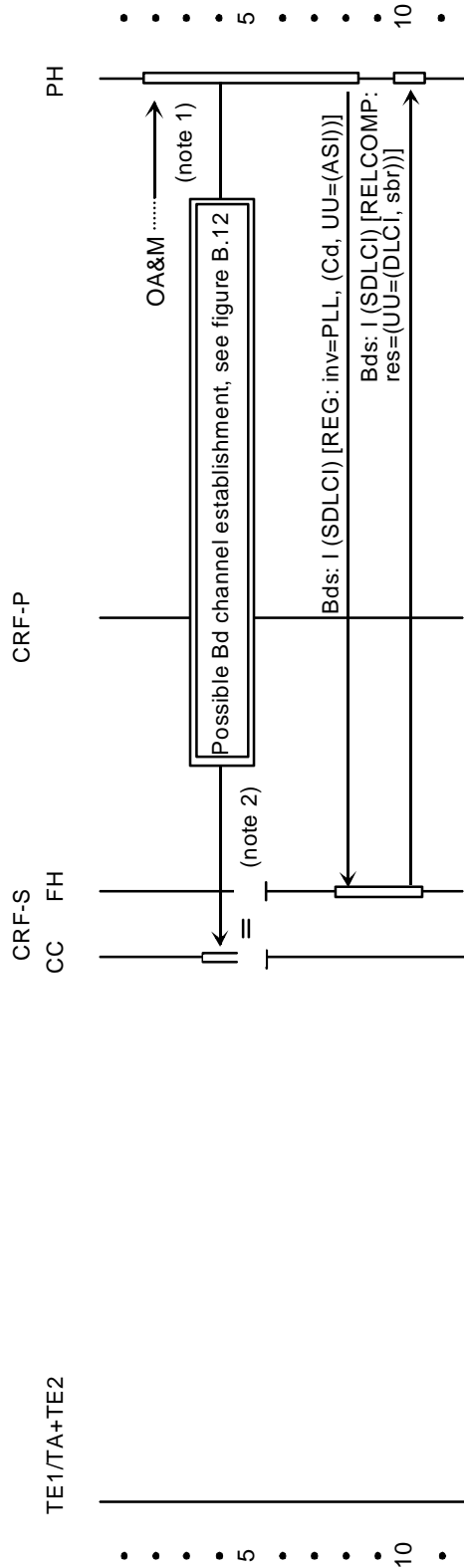
## B.7 Dynamic provisioning for D-channel PLL service

### B.7.1 PLL data link registration



NOTE 1: If no Bd-channel exists, i.e. no signalling data link exists, the CRF-S establishes one.

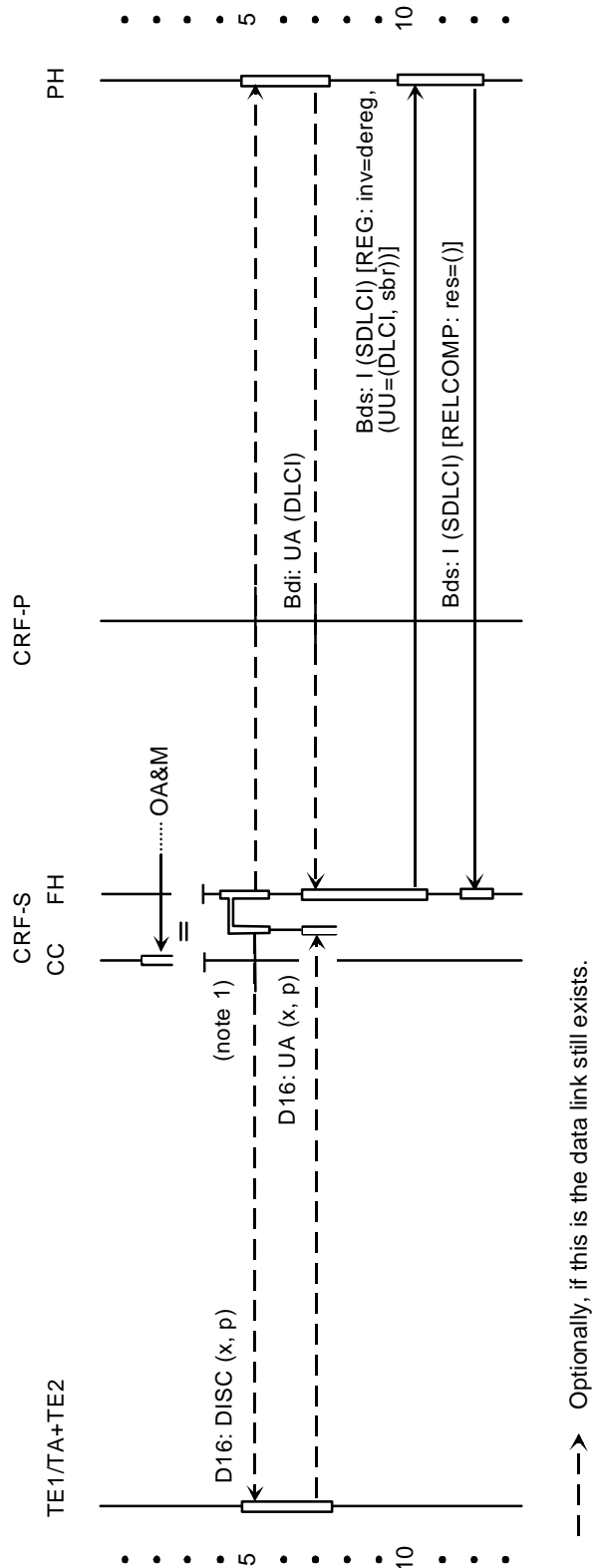
**Figure B.24: Registration by the CRF-S.  
 Signalling in the Bd-channel. No signalling on the subscriber access**



- NOTE 1: If no Bd-channel in the particular sub-bundle exists or the traffic load suggests the requirement for a new Bd-channel, the PH establishes one.
- NOTE 2: The FH is informed about the establishment of a new Bd-channel.

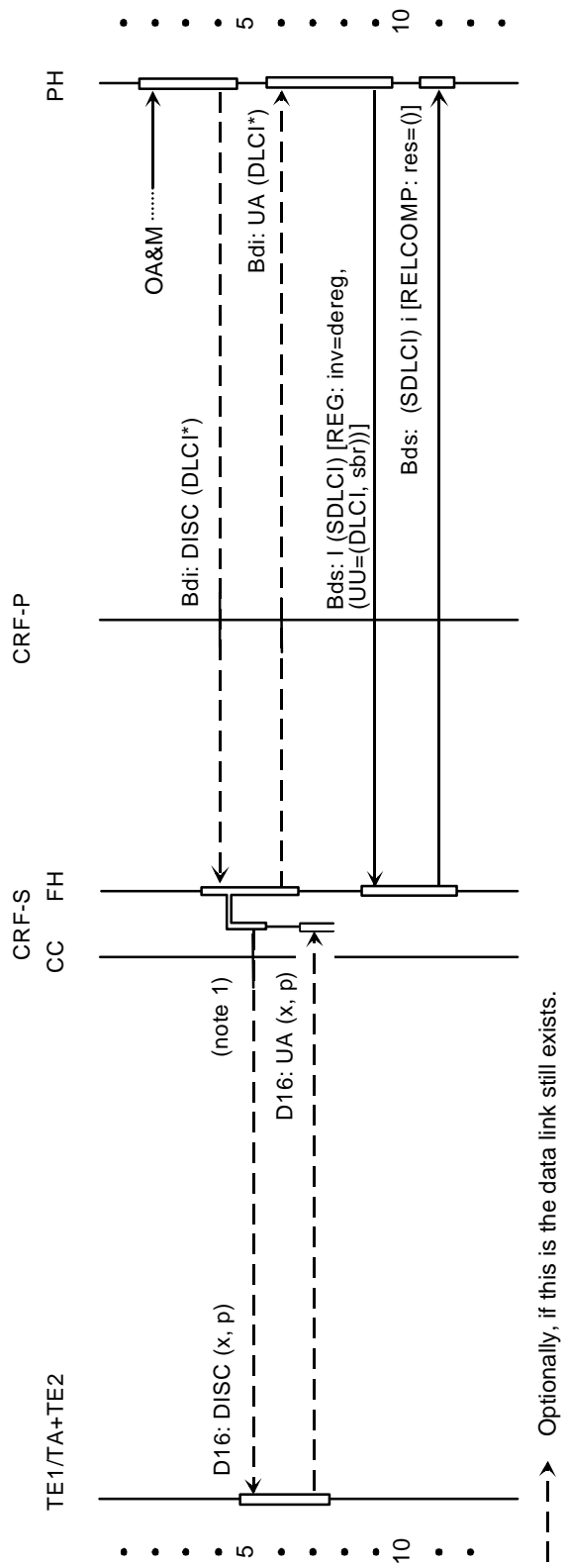
**Figure B.25: Registration by the PH.  
Signalling in the Bd-channel. No signalling on the subscriber access**

B.7.2 PLL data link deregistration



NOTE 1: Depending on the particular implementation, the layer 2 sequences at the subscriber access may be different from the ones shown in the diagram.

**Figure B.26: Deregistration by the CRF-S.**  
**Signalling in the Bd-channel. No signalling on the subscriber access**

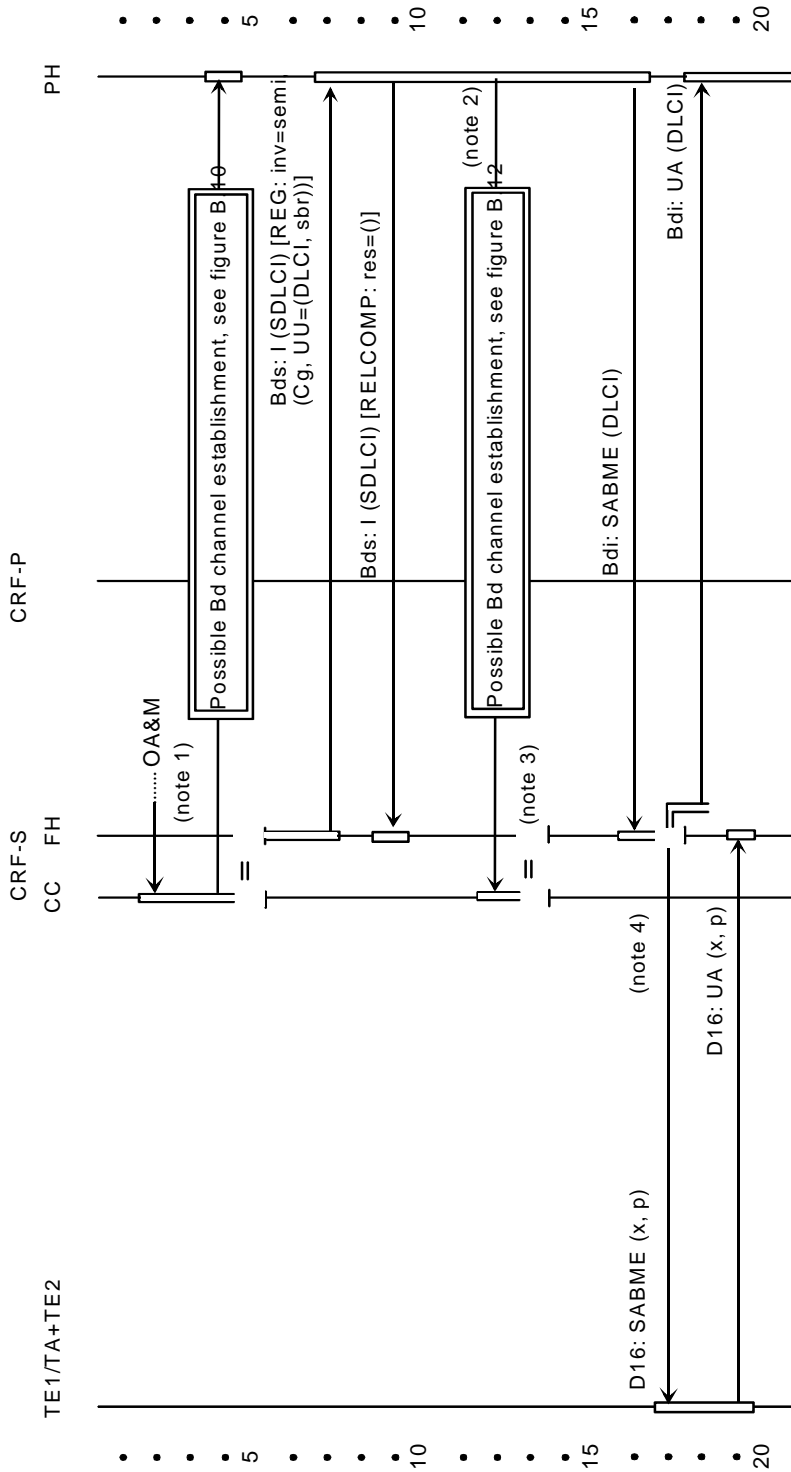


NOTE 1: Depending on the particular implementation, the layer 2 sequences at the subscriber access may be different from the ones shown in the diagram.

**Figure B.27: Deregistration by the PH.  
 Signalling in the Bd-channel. No signalling on the subscriber access**

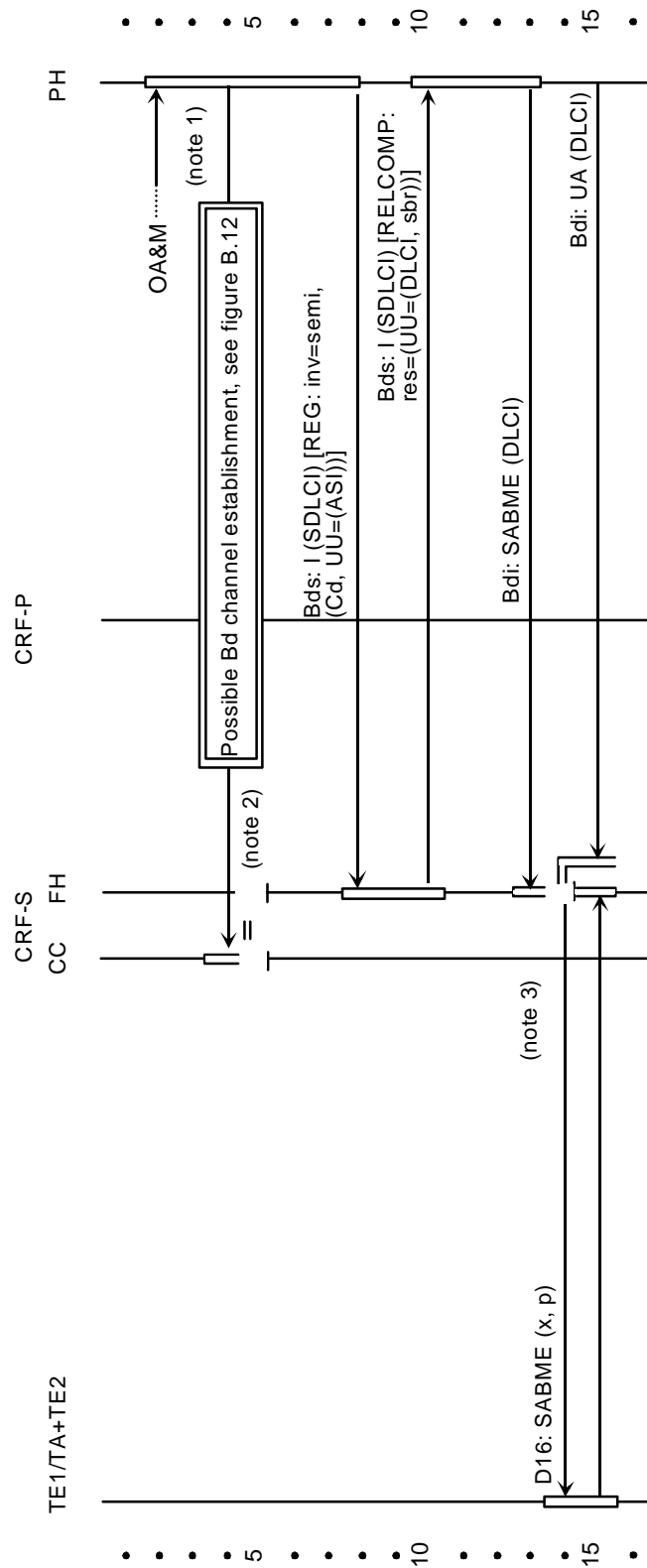
## B.8 Dynamic provisioning for D-channel semi-permanent service

### B.8.1 Semi-permanent data link registration



- NOTE 1: If no Bd-channel exists, i.e. no signaling data link exists, the CRF-S establishes one.  
 NOTE 2: If no Bd-channel in the particular sub-bundle exists, or the traffic load suggests the requirement for a new Bd-channel, the PH establishes one.  
 NOTE 3: The FH is informed about the establishment of a new Bd-channel.  
 NOTE 4: Depending on the particular implementation, the layer 2 sequences at the subscriber access may be different from the ones shown in the diagram.

**Figure B.28: Registration by the CRF-S.  
 Signalling in the Bd-channel. No signalling on the subscriber access**



- NOTE 1: If no Bd-channel in the particular sub-bundle exists or the traffic load suggests the requirement for a new Bd-channel, the PH establishes one.
- NOTE 2: The FH is informed about the establishment of a new Bd-channel.
- NOTE 3: Depending on the particular implementation, the layer 2 sequences at the subscriber access may be different from the ones shown in the diagram.

**Figure B.29: Registration by the PH.  
 Signalling in the Bd-channel. No signalling on the subscriber access**

**B.8.2 Semi-permanent data link deregistration**

Same as PLL data link deregistration (see annex B, subclause B.7.2).



## **Annex C (informative): Additional information for PVCs on switched long-duration B-channel access (case B)**

### **C.1 Introduction**

The provision of PVCs on switched long-duration B-channels is allowed by ETS 300 048 [7]. This possibility is not identified in ITU-T Recommendation X.31 [19]. A detailed description is not available.

In the following, guidelines are given to allow the offering of this service on the PHI in a way that it is as close as possible to the operation of the PVC in a PSPDN. In a PSPDN, a PVC is offered on a dedicated link where layer 1 and layer 2 are always kept in a active state. If the link is not available, the packet node considers the DTE as out of order and sends a Reset packet with cause "out of order" to the remote DTE. A similar approach is taken for ISDN where a not available B-channel is treated in the same way as an unavailable layer 1.

### **C.2 Procedure**

#### **C.2.1 Identification**

Each DTE having a PVC on a switched long-duration B-channel is identified by an CCITT Recommendation E.164 [13] number. This may be the access number if there is only one DTE on a given access or MSN/DDI in case of several DTEs on an access. This CCITT Recommendation E.164 [13] number points to a customized service profile containing information about the PVC and (maybe implicitly) that no notification for incoming VCs applies.

#### **C.2.2 B-channel establishment**

The user is responsible for the establishment and re-establishment of the B-channel. The SETUP message at the PHI interface contains the verified CCITT Recommendation E.164 [13] number of the user. The PH accepts the call and accesses the service profile which indicates the existence of the PVC.

#### **C.2.3 Layer 2 and layer 3 establishment**

Layer 2 is activated by normal procedures (i.e. DTE or PH). After this, a Layer 3 restart procedure follows which causes a Reset packet with cause "DTE operational" to the remote DTE.

#### **C.2.4 Error procedures**

In case of failures, which can not be recovered in Layer 2, either end may release the B-channel. The PH will send a Reset packet with cause "DTE out of order" to the remote DTE and the local DTE will try to re-establish the B-channel as soon as possible.

#### **C.2.5 Procedures for VCs on B-channels supporting PVCs**

The no notification class is used for incoming VCs on this B-channel. This means that incoming calls will be offered in band and no ETS 300 403-1 [11] procedures are used. When the B-channel is not available, new incoming calls will be cleared with cause "DTE out of order".

## **Annex D (informative): Multi-PRA configurations**

Considering that:

- the PHI may consist of multiple PRAs;
- dynamic Bd or Bb-channels may be supported, ports (time slots) may be preassigned by the PH either as having Bd or Bb-functionality and this preassignment is not known by the CRF-P.

The situation may then arise, that the CRF-P will try to establish a B-channel (Bb or Bd) on a PRA with available B-channel capacity (free time slots) but not of the requested type.

In this case additional functionality is required to enable the CRF-P to select the appropriate PRA for B-channel establishment.

Possible solutions are given below.

### **D.1 Selection by using numbers**

Specific numbers (internal network addresses) are used to distinguish between the two types of switched channels, i.e. one number for Bb-channels and one number for Bd-channels. In this case each PRA can consist only of one type of switched channels.

NOTE: The assignment of semi-permanent channels to any PRA is not excluded.

### **D.2 Selection by a hunting algorithm or a call deflection mechanism**

In the case that the CRF-P gets an indication from the PH that the requested channel type is not available at the selected PRA it will reattempt call establishment on another PRA.

NOTE: The procedures for the support of this mechanism are for further study.

### **D.3 Non-associated signalling**

In this case only one D-channel is used for signalling for all PRAs. Procedures are defined in CCITT Recommendation Q.931, but not in ETS 300 403-1 [11].

## **Annex E (normative): Switch-over and concentration procedures**

### **E.1 Introduction**

This annex specifies the procedure for the dynamic management of traffic on Bd-channels connected to a CRF-S. This procedure is optional.

### **E.2 Applicability**

The procedures are applicable to all cases of frame handling:

- centralized or decentralized FH architectures at the CRF-S;
- frame relay or frame switching techniques at the CRF-S;
- semi-permanent, PLL, switched (on-demand) user data links or the signalling data link;
- any Bd-channel.

### **E.3 Constraints**

No PH is required to perform dynamic traffic management. However, a PH which does perform dynamic traffic management may be capable of higher service reliability and better channel utilization.

### **E.4 Procedures**

These consist of procedures for switchover of a data link from one Bd-channel to another, and procedures to instigate switchover for the purposes of dynamic traffic management.

#### **E.4.1 Switchover procedures**

A PH performs switchover of a data link by starting to use a new Bd-channel for transmission of frames associated to the data link. An uncommitted CRF-S will accept frames on the new Bd-channel, and will send subsequent frames for the data link on this Bd-channel.

For a user data link, switchover is confined to Bd-channels in the same sub-bundle. Further restriction, e.g. confining switchover to the same type (semi-permanent, switched, or dynamic semi-permanent) of Bd-channel, is a matter for the PH. For the signalling data link, switchover may be between any Bd-channels in the whole bundle; this operation is called "concentration".

Two situations are distinguished:

- switchover during link establishment; and
- switchover of an established link.

##### **E.4.1.1 Switchover during link establishment**

This applies to outgoing PLL establishment, when the PH receives a SABME from the CRF-S and wishes to switchover to a different Bd-channel.

Two options are possible:

- a) the PH may send the associated UA-frame on the Bd-channel selected for the data link;
- b) the PH may send a SABME-frame on the Bd-channel selected for the data link, thus forcing a collision (and retransmission by the CRF-S).

#### E.4.1.2 Switchover of an established link

To successfully switchover an established user data link, or the signalling data link, there are two important considerations:

- a) to avoid the possibility that a frame sent out by the PH over the old Bd-channel is overtaken by a frame sent out by the PH over the new Bd-channel, the PH should not use the new Bd-channel until a guard time Txxx has elapsed since transmission of the last frame on the old Bd-channel. This time shall be greater than the maximum time between transmission of a frame by the PH and its reception and processing by the CRF-S;
- b) when the guard time has elapsed, the PH should send a command frame on the new Bd-channel, thus ensuring, by normal LAPD retransmission procedures, that the CRF-S is informed of the switchover. If the PH discards frames received via the old Bd-channel, this procedure also avoids deadlock even when the frame sent by the PH would be lost.

The LAPD retransmission time T200 is, by definition, greater than the maximum time between transmission of a command frame and reception of the corresponding response or acknowledgement (see CCITT Recommendations Q.921 subclause 5.9.1). A simple rule is therefore to set Txxx equal to T200.

#### E.4.2 Detailed procedure

- a) At the instant that the PH decides to switchover, it shall start timer Txxx.
- b) While timer Txxx is running, the PH shall not transmit any frame for the data link.
- c) While timer Txxx is running, the PH may either discard or process frames for the data link received from the CRF-S on the old Bd-channel.
- d) On expiry of timer Txxx, the PH shall begin transmission of frames for the data link on the new Bd-channel and shall discard frames for the same data link received on any other Bd-channel. If no command frame is available, the PH shall execute the connection verification procedures defined in CCITT Recommendations Q.921, subclause 5.10.3.3.

### E.5 Traffic management considerations

For the purposes of dynamic traffic management, switchover may be instigated in the following general cases:

- Bd-channel failure or malfunction;
- unexpected overload; and
- concentration of under-loaded Bd-channels.

#### E.5.1 Bd-channel failure or malfunction

The PH may optionally switchover in the following cases:

- a) Bd-channel is cleared (see subclause 11.2.5.2);
- b) restart on PHI (see subclause 11.2.5.3);
- c) monitored performance parameters exceeded (see subclause 8.3.2.3);
- d) in addition, a PH may switchover an individual data link when performance degradation is detected (for instance, timeout).

### **E.5.2 Unexpected overload**

The PH may optionally switchover in the following cases:

- a) exceeded thresholds on Bd-channel utilization or processor utilization (see subclause 8.3.2.2);
- b) in addition, the PH may switchover an individual data link when excessive delays between commands and their responses are detected.

### **E.5.3 Concentration of under-loaded Bd-channels**

The PH may optionally switchover when performance measurements (see subclause 8.3.2.2) indicate that several Bd-channels are lightly loaded, and at least one of them is a switched Bd-channel.

The PH will switchover data links from a chosen switched Bd-channel. When all data links have been switched over, the PH will release the Bd-channel.

## **E.6 Modifications to the main part of the specification**

NOTE: In the following, the subclauses of the main part to be modified are indicated.

### **E.6.1 General interface architecture**

Subclause 6.2:

Committed CRF-S: A committed CRF-S has no switchover or concentration capability.

Uncommitted CRF-S: An uncommitted CRF-S always transmits frames for each data link on the Bd-channel on which the last frame for that data link was received from the PH.

NOTE: A CRF-S can be either committed or uncommitted.

### **E.6.2 Data transfer**

Subclause 6.3.3.1: For uncommitted CRF-Ss, the one-to-one correspondence between a SAPI=16 data link connection on the subscriber's D-channel and a data link connection on a Bd-channel is relaxed to a one-to-one correspondence between a SAPI=16 data link on the subscriber's D-channel and a data link connection in a sub-bundle as the particular Bd-channel may be altered at any time by a PH connected to an uncommitted CRF-S. This change may be effected by the use of any frame, and is called switchover.

In addition, for an uncommitted CRF-S, the maximum number of data links to be established on a Bd-channel need not be known, as well as other possible load characteristics for Bd-channels, as it is a matter for the PH only, and need not be agreed bilaterally for any period of time.

### **E.6.3 Load sharing**

Subclause 8.3.2.2.2:

When connected to a committed CRF-S, the PH may perform load sharing only at data link establishment time.

When connected to an uncommitted CRF-S, the PH may perform load sharing at any time.

In any case, the CRF-S may also perform load sharing at data link establishment time, ranging from simple algorithms (such as cyclic search) up to more refined algorithms. Such algorithms are not necessary but will reduce the frequency and necessity of switchover during data link establishment by the PH.

#### **E.6.4 Bd-inband signalling**

Subclause 8.4.2.3.2:

In addition, when connected to an uncommitted CRF-S, the PH may optionally switchover in case of unexpected load or in order to concentrate under-loaded Bd-channels.

#### **E.6.5 Switchover and concentration procedure**

Clause 9:

An uncommitted CRF-S shall:

- a) accept any frame associated to any user data link on any Bd-channel of the sub-bundle at any time;
- b) accept any frame associated to the signalling data link on any Bd-channel of the bundle at any time;
- c) transmit frames associated to any (user or signalling) data link on the Bd-channel on which the last frame for that data link was received from the PH.

#### **E.6.6 Procedures for data link establishment by the CRF-S**

Subclause 10.3.2.3 b):

NOTE: When connected to an uncommitted CRF-S, the PH is free to immediately switchover to another Bd-channel.

#### **E.6.7 Bd-channel is cleared**

Subclause 12.3.5.2:

NOTE: Optionally, when connected to an uncommitted CRF-S, the PH may attempt switchover of established data links to other Bd-channels.

#### **E.6.8 Call collision on the Bd-channel**

Subclause 12.4.2.3:

If connected to an uncommitted CRF-S, the PH shall send no frame on the Bd-channel selected by the CRF-S. It sends an UA-frame on the Bd-channel selected by itself, and proceeds with data link establishment.

## Annex F (normative): Reset procedures

The procedure outlined below is optional.

### F.1 Procedure

The RESET procedure is used to return the Bd-channel to an idle condition either after a failure recovery or at the initialisation time. It indicates to the remote end of the Bd-channel that layer 2 procedures and resources associated to SAPI 16 have to be initialised.

At the originating side:

- appropriate internal actions to release all layer 2 SAPI 16 resources are initiated and the PH/CRF-S transmits a RESET REQUEST UI frame and the Channel Reset Timer (TCR) is started;
- when receiving the response timer TCR is stopped and new data links can again be established on this Bd-channel;
- when timer TCR expires, the RESET REQUEST message is sent again, timer TCR is restarted. If a response is received before TCR has expired NCR times, timer TCR is stopped and new data links can be established on the Bd-channel.

If no response is received prior to when timer TCR has expired NCR times, the reset procedure is deactivated and new data links cannot be established.

At the destination side:

- reception of a RESET REQUEST initiates the appropriate internal actions to release all the layer 2 SAPI 16 resources associated to the Bd-channel;
- upon completion of internal clearing, a RESET RESPONSE is sent. New data links can again be established on this Bd-channel.

### F.2 Coding

The DLCI value of these UI-frames is constructed as follows:

TCR::Specific timer (system parameter).

Default value is 10 seconds.

NCR::Number of retransmissions (system parameter).

Default value is 3.

SAPI:The SAPI value is set to 63.

LIC:The LIC value is set to zero.

The information field of the UI frames is structured as follows:

**Table F.1: Message structure for Bd-channel management**

8	7	6	5	4	3	2	1
Management entity identifier							
Message Type							

**Table F.2: Message codes for Bd-channel management**

Message name	Management Entity ID	Message Type
Reset request	0001 0000	0000 0011
Reset response	0001 0000	0000 0100



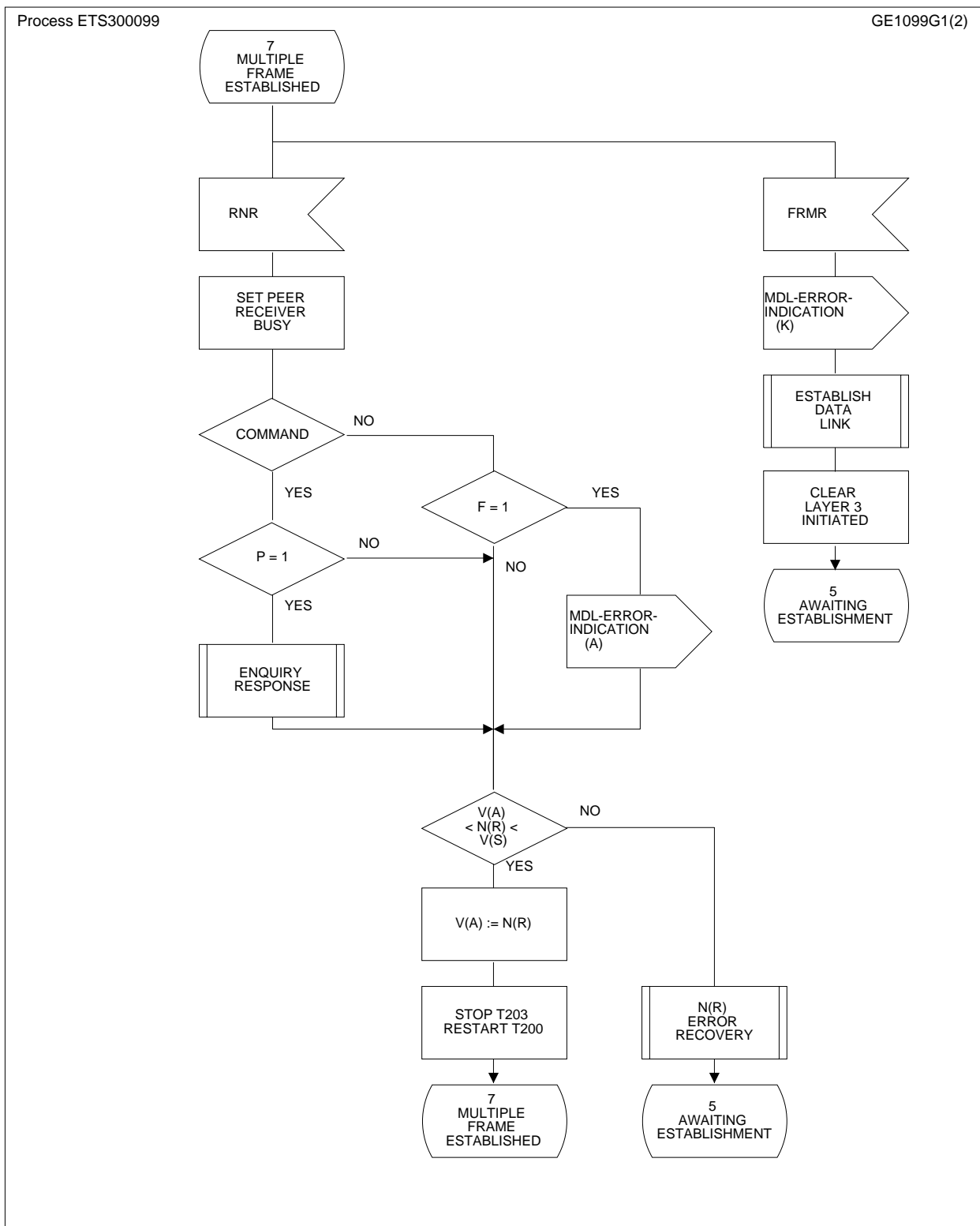
## **Annex G (informative): Layer 2 SDL diagrams and state tables**

### **G.1 SDL diagrams**

The following SDL diagrams and state table fragments are those parts of the SDL diagrams and state tables of ETS 300 402-2 [10] which need modification due to the introduction of two timer values for T200.

In all unmodified instances, "value 1" for timer T200 is used.

NOTE: Timer T200 is activated with "value 2" when waiting for the next polling cycle in the peer busy condition.



NOTE: Timer T200 is activated with "value 2" when waiting for the next polling cycle in the peer busy condition.

Figure G.1

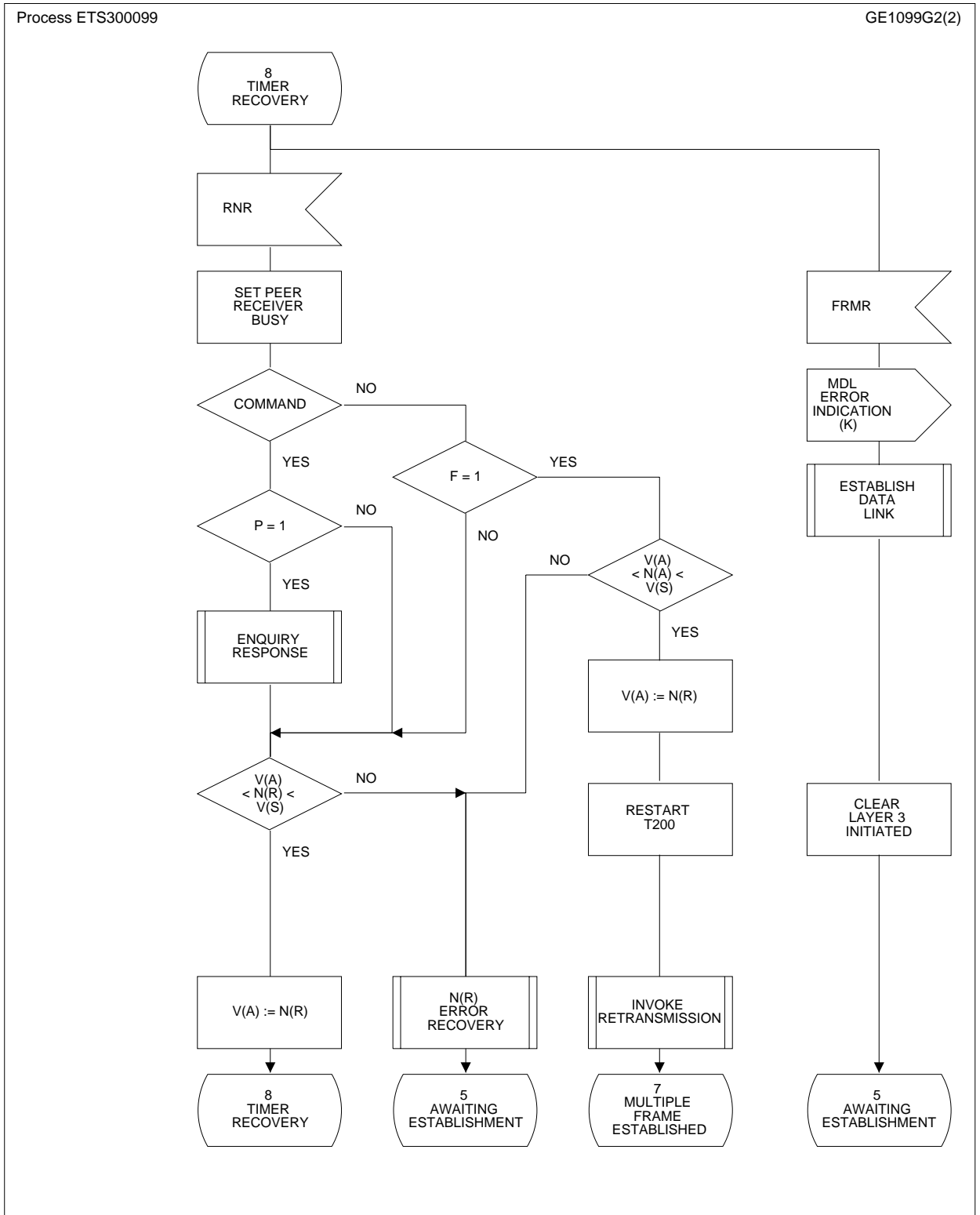


Figure G.2

## G.2 Key to the state transition tables

### G.2.1 Definition of a cell of the state transition table

Event	State ACTIONS X	X defines the transition to the next state X empty indicates "remain in the current state"
-------	-----------------------	---

### G.2.2 Key to the contents of a cell

V(S)=V(A)=N(R)      Collective term for the two actions V(S)=N(R) and V(A)=N(R).

Timer T200      Start timer T200 if not already running.

(A0)      The codes used in MDL-ERROR-INDICATION signals are defined in table 11-1/CCITT Recommendation Q.921, in Appendix II. When multiple codes are shown, only one applies.

The action	A	indicates	A	A
			A	A

## G.3 State transition tables

Table G.1

Transmitter condition	Timer recovery							
	Normal	Normal	Normal	Normal	Peer rec busy	Peer rec busy	Peer rec busy	Peer rec busy
Receiver condition	Normal	Rej recovery	Own rec busy	Rej & own rec busy	Normal	Rej recovery	Own rec busy	Rej & own rec busy
State number	8.0	8.1	8.2	8.3	8.4	8.5	8.6	8.7
RNR command P=1 V(A) ≤ N(R) ≤ V(S)	TX RR F=1 V(A)=N(R) 8.4	TX RR F=1 V(A)=N(R) 8.5	TX RNR F=1 V(A)=N(R) 8.6	TX RNR F=1 V(A)=N(R) 8.7	TX RR F=1 V(A)=N(R)		TX RNR F=1 V(A)=N(R)	
RNR command P=0 V(A) ≤ N(R) ≤ V(S)	V(A)=N(R) 8.4	V(A)=N(R) 8.5	V(A)=N(R) 8.6	V(A)=N(R) 8.7	V(A)=N(R)			
RNR response F=0 V(A) ≤ N(R) ≤ V(S)								
RNR response F=1 V(A) ≤ N(R) ≤ V(S)	V(S)=N(R) RESTART T200=V2 V(A)=N(R) 7.4	V(S)=N(R) RESTART T200=V2 V(A)=N(R) 7.5	V(S)=N(R) RESTART T200=V2 V(A)=N(R) 7.6	V(S)=N(R) RESTART T200=V2 V(A)=N(R) 7.7	V(S)=N(R) RESTART T200=V2 V(A)=N(R) 7.4	V(S)=N(R) RESTART T200=V2 V(A)=N(R) 7.5	V(S)=N(R) RESTART T200=V2 V(A)=N(R) 7.6	V(S)=N(R) RESTART T200=V2 V(A)=N(R) 7.7
RNR command P=1 N(R) error	TX RR F=1 MDL-ERR-IND(J) RC=0 TX SABME P=1 RESTART T200 5.1		TX RR F=1 MDL-ERR-IND(J) RC=0 TX SABME P=1 RESTART T200 5.1		TX RR F=1 MDL-ERR-IND(J) RC=0 TX SABME P=1 RESTART T200 5.1		TX RR F=1 MDL-ERR-IND(J) RC=0 TX SABME P=1 RESTART T200 5.1	
RNR command P=0 N(R) error	MDL-ERR-IND(J) RC=0 TX SABME P=1 RESTART T200 5.1							
RNR response F=0 N(R) error								
RNR response F=1 N(R) error								

NOTE: "Restart T200 = V2" means that T200 is restarted after having been set to value 2.

Table G.2

Transmitter condition	Multiple frame established							
	Normal	Normal	Normal	Normal	Peer rec busy	Peer rec busy	Peer rec busy	Peer rec busy
Receiver condition	Normal	Rej recovery	Own rec busy	Rej & own rec busy	Normal	Rej recovery	Own rec busy	Rej & own rec busy
State number	7.0	7.1	7.2	7.3	7.4	7.5	7.6	7.7
RNR command P=1 N(R) = V(S)	TX RR F=1 STOP T203 RESTART T200=V2 V(A)=N(R) 7.4	TX RR F=1 STOP T203 RESTART T200=V2 V(A)=N(R) 7.5	TX RNR F=1 STOP T203 RESTART T200=V2 V(A)=N(R) 7.6	TX RNR F=1 STOP T203 RESTART T200=V2 V(A)=N(R) 7.7	TX RR F=1 RESTART T200=V2 V(A)=N(R)		TX RNR F=1 RESTART T200=V2 V(A)=N(R)	
RNR command P=0 N(R) = V(S)	STOP T203 RESTART T200=V2 V(A)=N(R) 7.4	STOP T203 RESTART T200=V2 V(A)=N(R) 7.5	STOP T203 RESTART T200=V2 V(A)=N(R) 7.6	STOP T203 RESTART T200=V2 V(A)=N(R) 7.7	RESTART T200=V2 V(A)=N(R)			
RNR response F=0 V(A) ≤ N(R) ≤ V(S)								
RNR response F=1 N(R) = V(S)	MDL-ERR-IND(A) STOP T203 RESTART T200=V2 V(A)=N(R) 7.4	MDL-ERR-IND(A) STOP T203 RESTART T200=V2 V(A)=N(R) 7.5	MDL-ERR-IND(A) STOP T203 RESTART T200=V2 V(A)=N(R) 7.6	MDL-ERR-IND(A) STOP T203 RESTART T200=V2 V(A)=N(R) 7.7	MDL-ERR-IND(A) RESTART T200=V2 V(A)=N(R) 7.6			
RNR command P=1 V(A) ≤ N(R) ≤ V(S)	TX RR F=1 RESTART T200=V2 V(A)=N(R) 7.4	TX RR F=1 RESTART T200=V2 V(A)=N(R) 7.5	TX RNR F=1 RESTART T200=V2 V(A)=N(R) 7.6	TX RNR F=1 RESTART T200=V2 V(A)=N(R) 7.7	TX RNR F=1 RESTART T200=V2 V(A)=N(R)		TX RNR F=1 RESTART T200=V2 V(A)=N(R)	
RNR command P=0 V(A) ≤ N(R) ≤ V(S)	RESTART T200=V2 V(A)=N(R) 7.4	RESTART T200=V2 V(A)=N(R) 7.5	RESTART T200=V2 V(A)=N(R) 7.6	RESTART T200=V2 V(A)=N(R) 7.7	RESTART T200=V2 V(A)=N(R)			
RNR response F=0 V(A) ≤ N(R) ≤ V(S)								
RNR response F=1 V(A) ≤ N(R) ≤ V(S)	MDL-ERR-IND(A) RESTART T200=V2 V(A)=N(R) 7.4	MDL-ERR-IND(A) RESTART T200=V2 V(A)=N(R) 7.5	MDL-ERR-IND(A) RESTART T200=V2 V(A)=N(R) 7.6	MDL-ERR-IND(A) RESTART T200=V2 V(A)=N(R) 7.7	MDL-ERR-IND(A) RESTART T200=V2 V(A)=N(R)			

NOTE: "Restart T200 = V2" means that T200 is restarted after having been set to value 2.

## Annex H (normative): Coding of the BC and LLC information element

### H.1 BC information element for circuit switched bearer capability

The bearer capability "information element" shall be coded as shown in table H.1. This coding is used for the establishment of Bb-channels access the PHI for case A services (see subclauses 10.2.2 and 10.2.3) or for the establishment of dynamic Bd-channels of circuit mode procedures are used (see subclauses 10.4.3 and 10.4.4).

**Table H.1: BC coding for circuit mode B-channel establishment**

<b>Octet</b>	<b>Information element field</b>	<b>Field value</b>
3	Coding standard	CCITT standardizing coding
	Information transfer capability	Unrestricted digital information
4	Transfer mode	Circuit mode
	Information transfer rate	64 kbit/s
5	User information layer 1 protocol	(note)
6	User information layer 2 protocol	(note)
7	User information layer 3 protocol	(note)
NOTE:	This octet is not transmitted by the PH. If it is received by the PH, it is ignored.	

## H.2 LCC information element for case A services

The "lower layer compatibility" information element shall be coded as shown in table H.2. This coding is used if a case A, B-channel has to be established by the PH due to an incoming ITU-T Recommendation X.25 [4] external call (see subclause 10.2.3).

**Table H.2: LLC coding for case A B-channel establishment**

Octet	Information element field	Field value
3	Coding standard	CCITT standardizing coding
	Information transfer capability	Unrestricted digital information
3a	Negotiation indicator	(NOTE)
4	Transfer mode	Circuit mode
	Information transfer rate	64 kbit/s
<b>Layer 1</b>		
5	User information layer 1 protocol	CCITT standardized rate adaption ITU-T Recommendation X.31 [19] HDLC flag stuffing
5a	Synchron / asynchron	(synchronous)
	Negotiation	(in-band negotiation not possible)
	User rate	(user rate at reference point R)
5b	intermediate rate	(note)
	NIC on Tx	
	NIC on Rx	
	Flow control on Tx	
	Flow control on Rx	
	Rate adaption header	
	Multi frame support	
	Mode of operation	
	Logical link identifier negotiation	
	Assignor/assignee	
In-band/outband negotiation		
5c	Number of stop bits	(note)
	Number of data bits	
	Parity	
5d	Duplex mode	(note)
	Modem type	
6	User information layer 2 protocol	ITU-T Recommendation X.25 [4], link layer
6a	Optional layer 2 protocol information	(note)
7	User information layer 3 protocol	ITU-T Recommendation X.25 [4], packet layer
7a	Optional layer 3 protocol information	(note)
NOTE:	This octet is not transmitted by the PH. If it is received by the PH, it is ignored.	

### H.3 BC information element for packet mode bearer capability

#### H.3.1 BC for Bb-channel establishment

The "bearer capability" information element shall be coded as shown in table H.3. This coding is used for the establishment of Bb-channels across the PHI for case B services (see subclauses 10.3.2 and 10.3.3).

**Table H.3: BC coding for packet mode Bb-channel establishment**

Octet	Information element field	Field value
3	Coding standard	CCITT standardized coding
	Information transfer capability	Unrestricted digital information
4	Transfer mode	Packet mode
	Information transfer rate	00000: packet
5	User information layer 1 protocol	(note)
6	User information layer 2 protocol	ITU T Recommendation X.25 [4], link layer
7	User information layer 3 protocol	ITU T Recommendation X.25 [4], packet layer
NOTE:	This octet is not transmitted by the PH. If it is received by the PH, it is ignored.	

#### H.3.2 BC for Bd-channel establishment

The "bearer capability" information element shall be coded as shown in table H.4. This coding is used for the establishment of dynamic Bd-channels across the PHI if packet mode procedures are used (see subclauses 10.4.3 and 10.4.4).

**Table H.4: BC coding for packet mode Bd-channel establishment**

Octet	Information element field	Field value
3	Coding standard	CCITT standardized coding
	Information transfer capability	Unrestricted digital information
4	Transfer mode	Packet mode
	Information transfer rate	00000: packet
5	User information layer 1 protocol	(note)
6	User information layer 2 protocol	01110: ETSI PHI Bd-channel link layer
7	User information layer 3 protocol	ITU T Recommendation X.25 [4], packet layer
NOTE:	This octet is not transmitted by the PH. If it is received by the PH, it is ignored.	



#### H.4 BC information element in the Bd-channel signalling link

The "bearer capability" information element shall be coded as shown in table H.5. This coding is used for the establishment of dynamic data links in the Bd-channel (see subclauses 10.5.2 and 10.5.3).

**Table H.5: BC coding for dynamic data link establishment**

Octet	Information element field	Field value
3	Coding standard	CCITT standardized coding
	Information transfer capability	Unrestricted digital information
4	Transfer mode	Packet mode
	Information transfer rate	00000: packet
5	User information layer 1 protocol	(note)
6	User information layer 2 protocol	ETS 300 402-2
7	User information layer 3 protocol	ITU T Recommendation X.25 [4], packet layer
NOTE:	This octet is not transmitted by the PH. If it is received by the PH, it is ignored.	

### Annex J (informative): SDL for management frame continuity check

These SDL diagrams are an example of an implementation of the continuity check procedures as defined in subclause 9.7.2.

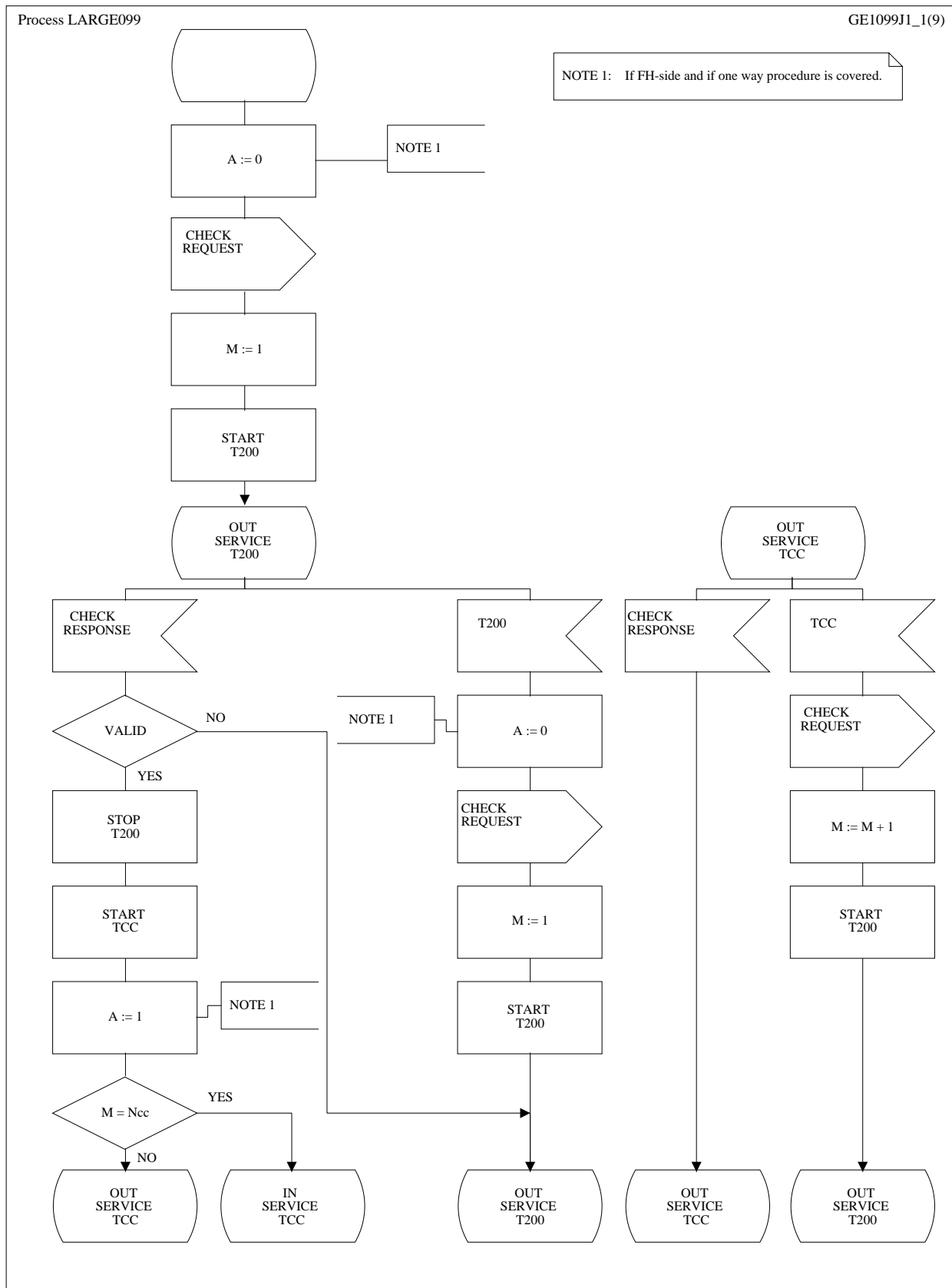


Figure J.1 (sheet 1 of 2): SDL for FH and for PH adopting both-way procedure

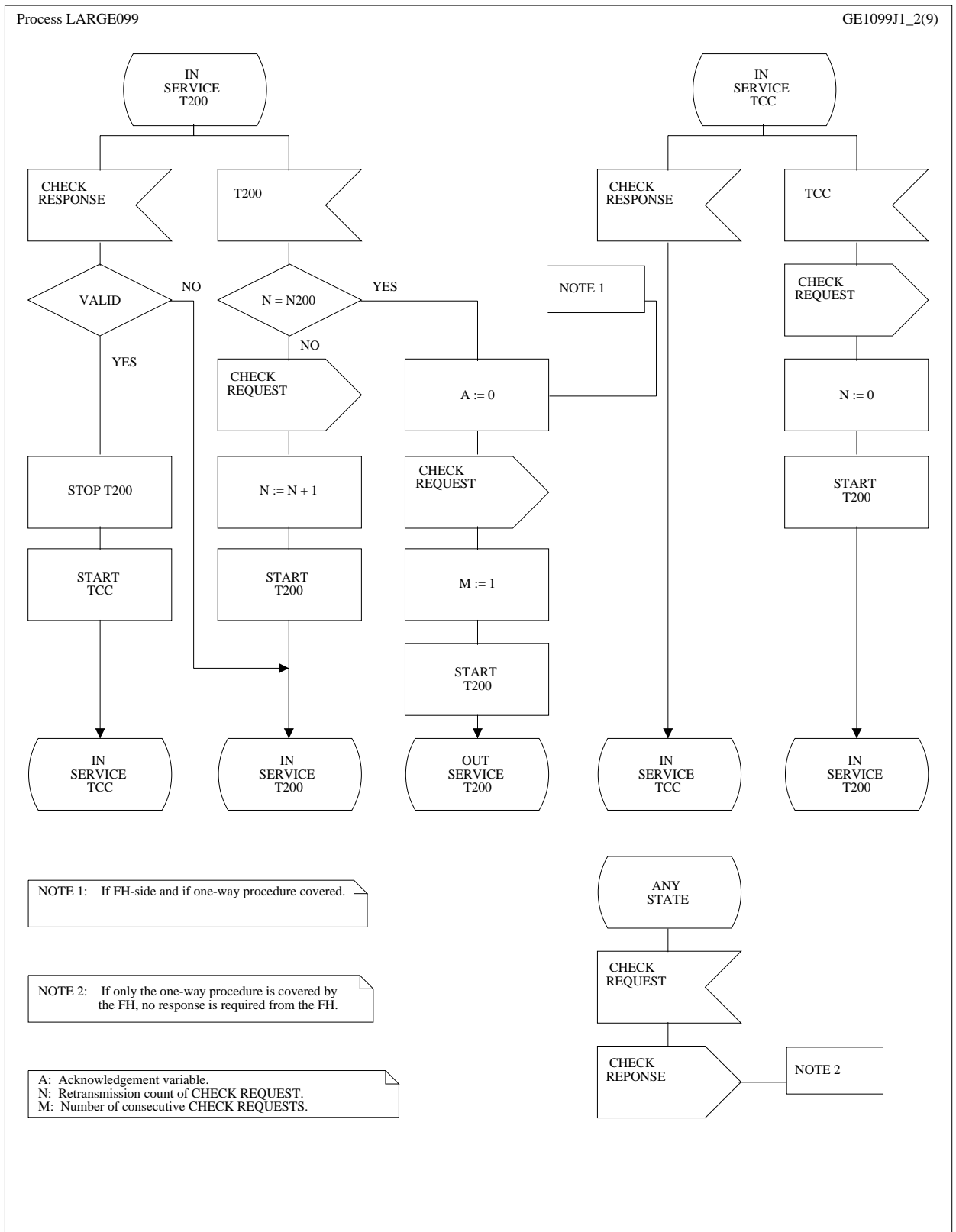


Figure J.1 (sheet 2 of 2): SDL for FH and for PH adopting both-way procedure

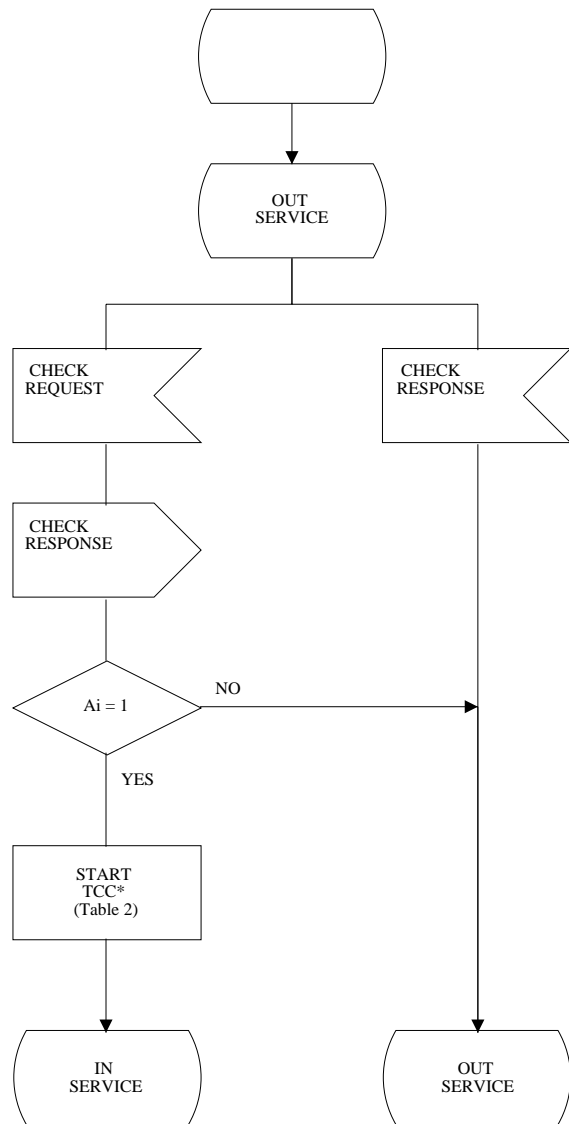


Figure J.2 (sheet 1 of 2): SDL for PH adopting one-way procedure

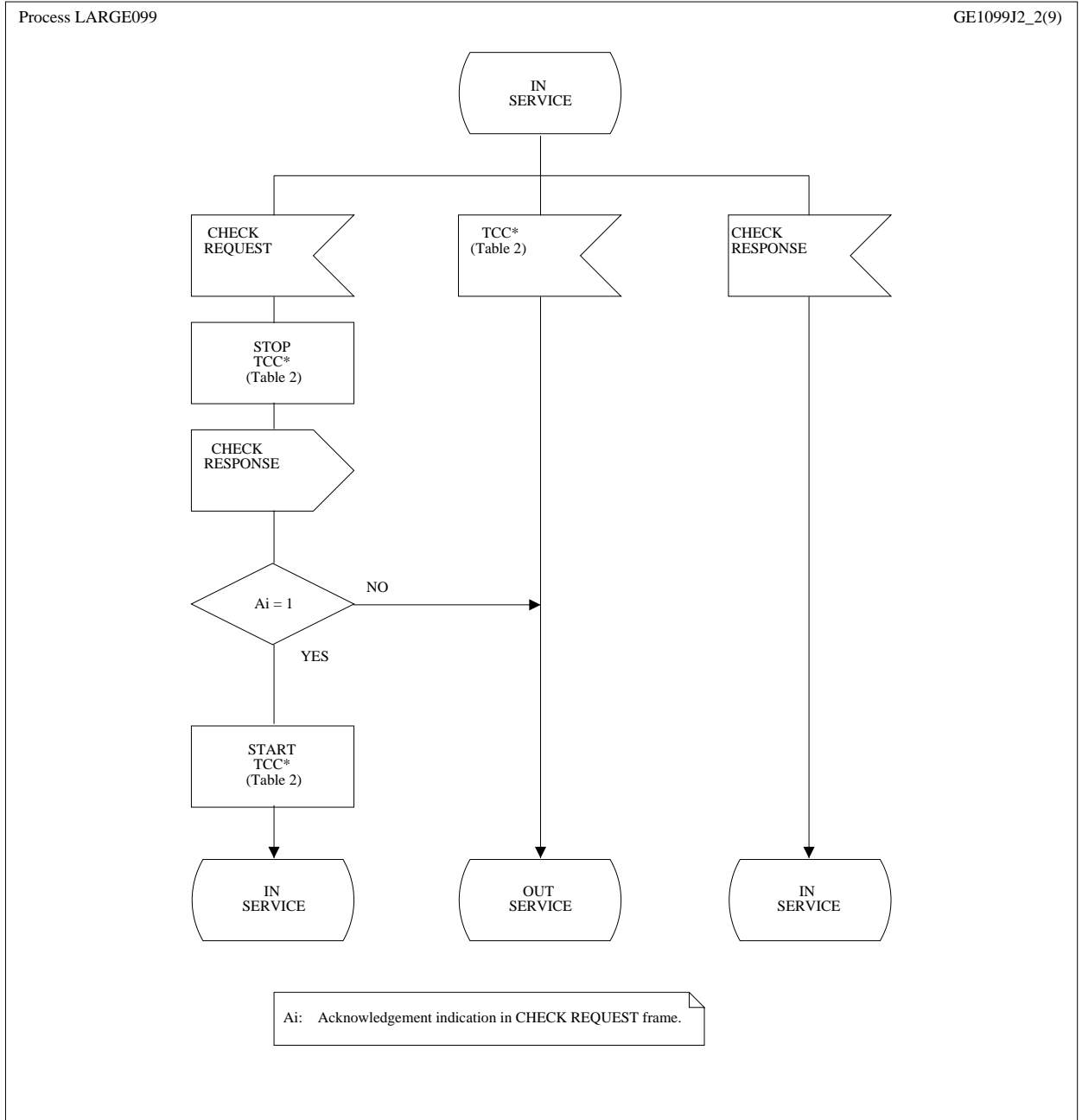


Figure J.2 (sheet 2 of 2): SDL for PH adopting one-way procedure

## Annex K (normative): Maintenance Flow for PMBS provided on the D-channel

### K.1 General

This annex defines a maintenance flow for packet mode bearer services provided on the D-channel. This maintenance flow is based on the use of UI frames with SAPI value 16 and is intended for logical connectivity checking and fault location along the logical link path.

This is provided through the loop procedure which enables the packet handler to send loop request message to different entities along the logical link path. The loop destination replies with a loop response message.

In case of errors on the links tested by the loop, diagnostic information may be included in the loop response message.

Other functions are for further study.

### K.2 Applicability

Maintenance flow is applicable for semipermanent and PLL access. Application of the maintenance flow for switched access is for further study.

Support of the maintenance flow is optional for both networks and subscriber equipment.

### K.3 Coding principles

#### K.3.1 Maintenance frame layouts.

The format of UI frames for the maintenance flow is described in figure K.1 for the ISDN access and in figure K.2 for the PHI.

Bit	8	7	6	5	4	3	2	1	Octets
	Flag								
	0	1	1	1	1	1	1	0	1
	Address field								
	0	S	A	P	I	0	C	O	2
			T	E	I			1	3
	Control field								
	0	0	0	P=0	0	0	1	1	4
	Management Entity Identifier								
	0	0	0	1	0	0	0	1	5
	Message								6
	FCS (first octet)								N-3
	FCS (second octet)								N-2
	Flag								N-1
	0	1	1	1	1	1	1	0	N

Figure K.1: Format of the UI frames for the maintenance flow on the D-channel

Bit	8	7	6	5	4	3	2	1	Octets
	Flag								
	0	1	1	1	1	1	1	0	1
	Address field								
	0	S	A	P	I		C	0	2
			L	I	C			0	3
			L	I	C			0	4
			L	I	C			1	5
	Control field								
	0	0	0	P=0	0	0	1	1	6
	Management Entity Identifier								
	0	0	0	1	0	0	0	1	7
	Message								8
	FCS (first octet)								N-3
	FCS (second octet)								N-2
	Flag								N-1
	0	1	1	1	1	1	1	0	N

Figure K.2: Format of the UI frame for the maintenance flow on the Bd channel

### K.3.2 Message format

Two messages are defined: loop request and loop response.

#### K.3.2.1 Loop request

The loop request message is sent by the originator of the loop. Table K.1 defines the loop request message content and the order of each information element.

Table K.1: Loop request message content

Information element	Reference	Type	Length
Message Type	K.3.3.1	M	1
Loop originator	K.3.3.2	M	1
Loop destination	K.3.3.3	M	1
Diagnostic	K.3.3.4	M	1
Test data	K.3.3.5	O	(note)
NOTE:	The minimum length is 1 octet. The maximum length is (N201 - 5) octets.		

**K.3.2.2 Loop response**

The loop response message is a reply to a loop request message. Table K.2 defines the loop response message content and the order of each information element.

**Table K.2: Loop response message content**

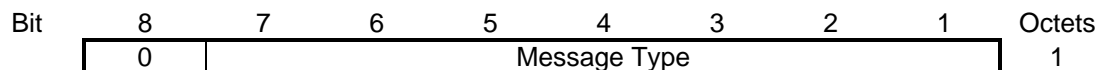
Information element	Reference	Type	Length
Message Type	K.3.3.1	M	1
Loop originator	K.3.3.2	M	1
Loop destination	K.3.3.3	M	1
Diagnostic	K.3.3.4	M	1
Test data	K.3.3.5	O	(note)
NOTE: The minimum length is 1 octet. The maximum length is (N201 - 5) octets.			

**K.3.3 Information elements coding**

**K.3.3.1 Message type**

The purpose of the message type is to identify the function of the message being sent.

The message type is coded as shown in figure K.3 and table K.3. Bit 8 is reserved for possible future use as an extension bit.



**Figure K.3: Message type**

**TABLE K.3: Message types**

Bits								
8	7	6	5	4	3	2	1	
0	0	0	0	0	0	0	0	escape to nationally specific message type (note)
0	0	0	0	1	0	0	1	- LOOP REQUEST
0	0	0	0	1	0	1	0	- LOOP RESPONSE
NOTE: When used, the message type is defined in the following octet(s), according to the national specification.								



### K.3.3.2 Loop originator

The purpose of the loop originator information element is to identify the entity that initiates the loop procedure.

The loop originator information element octet is coded as shown in table K.4.

**Table K.4: Loop originator information element**

Bits								
8	7	6	5	4	3	2	1	
0	1	0	0	0	0	0	0	- PH
reserved.								Values as identified in table K.5 are

### K.3.3.3 Loop destination

The purpose of the loop destination information element is to identify in the loop request message the entity which should respond. In the loop response message, this information element identifies the entity which actually responds.

The destination loop information element octet is coded as shown in table K.5.

**Table K.5: Loop destination information element**

Bits								
8	7	6	5	4	3	2	1	
0	0	0	0	0	0	0	1	- TE1
0	0	0	0	0	0	1	0	- TA
0	0	0	0	0	1	0	0	- NT2
0	0	0	0	1	0	0	0	- PTN
0	0	0	0	1	1	1	1	- LAPD termination (note)
0	1	0	0	0	0	0	0	- Reserved
1	0	0	0	0	0	0	0	- FH CRF-S
1	0	0	0	0	0	0	1	- FH CRF-P

NOTE: A LAPD termination is the entity along the logical link path farthest from the packet handler. This code point is used by the loop originator in the loop request message when it wants to initiate an end-to-end loop, but has no knowledge of the equipment which actually terminates the logical link. This code point shall not be used in loop response message.

### K.3.3.4 Diagnostic

The diagnostic information element provides for the entity that actually replies to the loop request message, a means to inform about possible error conditions.

The diagnostic information element octet is coded as shown in table K.6.

**Table K.6: Diagnostic**

Bits								
8	7	6	5	4	3	2	1	
0	0	0	0	0	0	0	0	- Loop successful
0	0	0	0	0	0	0	1	- DCLI not registered
0	0	0	0	0	0	1	0	- Loop destination unreachable
0	0	0	0	0	0	1	1	- Reserved for future extension
0	1	1	up to 1	1	1	1	1	
1	0	0	0	0	0	0	0	- Network dependent diagnostics
1	1	1	up to 1	1	1	1	1	

### K.3.3.5 Test data

The test data information element provides a means for the loop originator to send in a loop request message a series of octets. The loop destination which replies to a loop request message shall transparently include the received test data into the loop response message.

The test data information element octets are coded as shown in table K.7.

**Table K.7: Test data information element**

The test data consists of a series of octets whose codings and semantics are determined by the loop originator of the loop request message.

## K.4 Procedures

### K.4.1 General

The procedures described in this section may be initiated regardless of the state of the logical link (activated or deactivated).

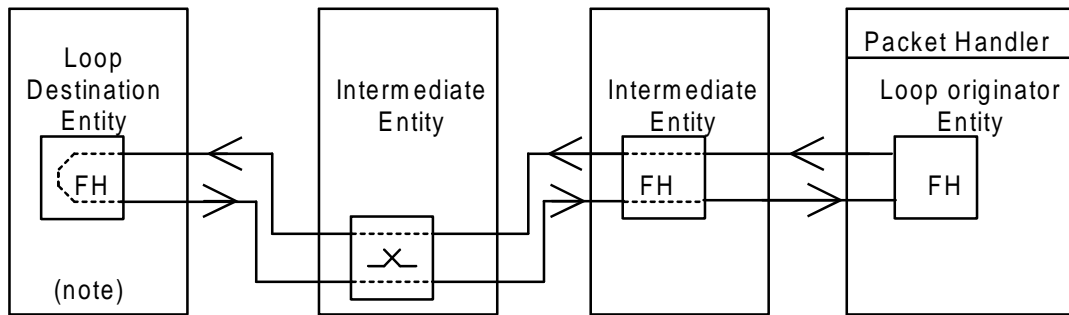
If several physical paths exist between involved entities of the maintenance flow, each UI frame related to a given deactivated logical link, may be routed on a one by one basis (i.e. independently) on the available paths.

On the other hand, UI frames related to a given activated logical link shall be sent on the particular path of that logical link.

Since there is a delay between local and end-to-end activation/deactivation of the logical link, UI frame related to a given activated logical link may be received on different Bd channel within a sub-bundle.

#### K.4.2 Loop procedure

Figure K.4 illustrates the principle of the loop procedure.



NOTE: Only entities including a frame handling function can terminate a loop.

Figure K.4

#### Loop procedure principle

The packet handler, as the loop originator, entity sends a loop request message. This loop request message is relayed by intermediate entities up to the loop destination entity (TE1, TA, NT2, PTN, ISDN FHs). The destination entity replies with a loop response message which is in turn relayed up to the packet handler.

The conditions used by a packet handler to determine when it wants to initiate a loop procedure on a particular logical link are network dependent.

##### K.4.2.1 Loop request message generation by the packet handler

The loop request message is generated and sent by the packet handler as follows:

- the loop originator information element octet is set to packet handler code point (see table K.4);
- the loop destination information element octet codes the identity of the entity that is requested to respond to the loop request message. The code point LAPD termination is used when the packet handler wishes to initiate an end-to-end loop procedure but has no knowledge of the actual entity which terminates the logical link (e.g. TE1, TA) (see table K.5);
- the diagnostic information element octet is set to 0 by default, since it carries no meaningful information in the loop request message;
- a test data information element may be included whose content is determined by the packet handler (see table K.7).

The packet handler will use a timer ( $T_{loop}$ ) to detect that loop response messages have not been received.

#### **K.4.2.2 Loop request message relaying**

Intermediate entities which are not identified in the loop destination information element of received loop request messages should relay the UI frames on the adjacent logical link path.

In case an intermediate entity knows that the relaying of the UI frames is not possible on the adjacent logical link path, the intermediate entity shall act as a loop destination entity and send a loop response message to the packet handler as described in K.4.2.4. In such case, the diagnostic information element is used to report the impossibility of relaying the loop request message by inserting either "Destination loop unreachable", "DLCI not registered" or network dependent code points.

If a TE1/TA/NT2/PTN, that is the LAPD termination entity receives a loop request message with a loop destination information element different from its own loop destination code point and from "LAPD termination", it should discard this loop request message.

#### **K.4.2.3 Loop request message reception by the requested loop destination**

The entity identified in the loop destination information element of the received loop request message replies by sending a loop response message to the packet handler as described in K.4.2.4.

If a TE1/TA/NT2/PTN, that is the LAPD termination entity receives a loop request message with a loop destination information element equal to "LAPD termination", it should also reply with a loop response message.

The diagnostic information element should normally be coded as "loop successful".

In situations where a LAPD termination entity as the requested loop destination is able to reply to the loop, but has information about faults further on, network dependent diagnostic may be used to indicate such faults (e.g. a Terminal Adapter could report the state of the R interface).

#### **K.4.2.4 Loop response message generation by the actual loop destination**

The loop response message is generated and sent by the actual loop destination as follows:

- the loop originator information element octet is set to packet handler code point (see table K.4);
- the loop destination information element octet codes the identity of the actual destination loop. (see table K.5);
- the diagnostic information element octet is coded taking into account the fact that the actual loop destination is or is not the requested loop destination or indicating other faults (see K.4.2.2 and K.4.2.3);
- if a test data information element is received in the loop request message, then the very same test data information element content shall be included.

#### **K.4.2.5 Loop response message relaying**

All Intermediate entities up to the packet handler should relay on the adjacent logical link path loop response messages.

In case, an intermediate entity knows such relaying is not possible, it shall discard these loop response messages.

#### **K.4.2.6 Loop message reception by the packet handler**

The packet handler checks:

- the loop destination information element;
- the diagnostic information element;
- the test data information element.

The packet handler stops the relevant timer  $T_{loop}$ .

It also determines what is the entity that actually responds and, if this entity differs from the requested loop destination what is the reason, in order to detect possible logical connectivity problems or other fault on the logical link, for fault location and analysis.

Subsequent actions undertaken by the packet handler are network dependent.

#### **K.4.2.7 Time-out of the loop timer**

Time-out of the timer  $T_{loop}$  means that either the corresponding loop request or loop response messages have been lost or discarded and consequently that the loop procedure has failed.

Actions undertaken by the packet handler upon loop timer time-out are network dependent

#### **K.4.2.8 Loop timer value**

The value of the timer  $T_{loop}$  is network dependent.

#### **K.4.3 Forward compatibility procedures**

For forward compatibility reasons, and because of national specific messages that may be defined, ISDN Frame Handlers but also subscriber frame handlers (e.g. contained in NT2 or PTN) should relay also maintenance frames, as described in K.3.1, whose message is not described in this annex.

For the same reasons, LAPD termination entities which are not able to process the content of received maintenance frames should discard them.

## **Annex L (normative): Support of PTNs**

The reference configuration, functional models and basic services of clauses 4 and 5 apply to both the coincident S/T and T-reference points. They support adequately the interworking of public ISDNs with PTNs implementing circuit switching, D-channel frame handling and packet handling functions. For PTNs implementing PHI-frame handling, additional reference configuration and basic services are defined in clause L.3.

### **L.1 PTN with CS or D-FH**

This covers the cases where the PTN has:

- circuit switching capabilities for interconnecting B-channels between the S- and T-reference points; and/or
- frame handling capabilities for interconnecting D-datalinks between S- and T-reference points.

The private users have a public number and, if they have a customized or standard profile, this profile shall be known to the public ISDN. Numbering, addressing and terminal selection by the PH is based on this number.

### **L.2 PTN with PH**

This covers the case where the PTN has packet handling capabilities. B-channel as well as D-channel services may be employed at the T-reference point.

The PTN has a public number and may have subscription to a customized or standard profile in the public ISDN. Numbering, addressing and terminal selection by the public PH is based on this number. The private users may also have a public number (e.g. DDI) but these numbers cannot have an own profile and will not be used for terminal selection by the public PH: they use the access connections and the service profile of the PTN.

### **L.3 PTN with PHI-FH**

This covers the case where the PTN has frame handling capabilities, in the sense of this ETS. D-channel traffic at the S-reference point is concentrated on B (Bd)-channels at the T-reference point.

The private users have a public number and, if they have a customized or standard profile, this profile shall be known to the public PH. The access profile is not known by the public CRF-S but it is in the PTN. Numbering, addressing and terminal selection by the PH is based on this number.

All prearrangements between the PTN and the PH required to operate a PHI-frame handler in the PTN apply. A specific subscription in the CRF is needed to one or more Bd-channel access methods.

### L.3.1 Reference configuration

The PTN implements the functions of the CRF-S regarding D-channel services, using the Bd-channel access services of the public ISDN. With regard to the reference configuration however the PTN cannot be referenced as the CRF-S, since the CRF-S is the public CRF at the T-reference point.

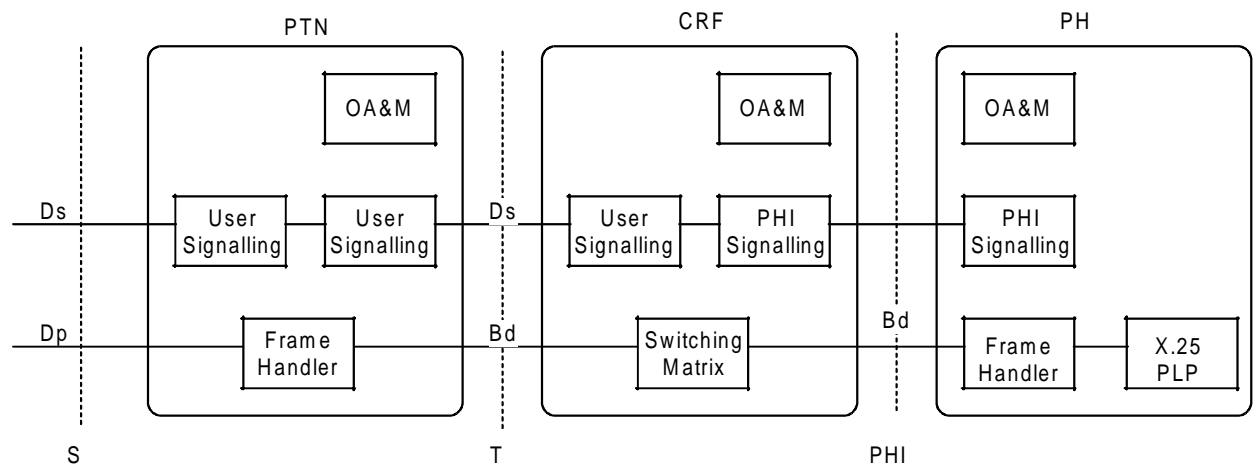


Figure L.1

### L.3.2 Services

Two Bd-channel access methods at the T-reference point are foreseen to support PTNs with a PHI-FH function.

#### L.3.2.1 Semi-permanent Bd-channel

The semi-permanent Bd-channel access method corresponds to a statically provisioned semi-permanent Bd-channel, as it is defined in this ETS.

#### L.3.2.2 Demand Bd-channel, long duration

The demand Bd-channel access method, long duration, corresponds to a dynamically provisioned semi-permanent Bd-channel, established by the PTN (with CRF-S function), as it is defined in this ETS.

When establishment of the Bd-channel uses packet mode procedures, then the Bd-channel demand access method is a basic service, characterised by the Bd-channel packet mode bearer capability (as specified in clause H.4).

### L.3.3 Signalling

The signalling procedures for Bd-channels established by the CRF-S (refer to subclauses 10.4.3 and 10.4.5) and for switched D-channel services (refer to subclause 10.5) apply, with the PTN assuming the role of the CRF-S.

Applicability of the signalling procedures for dynamic provisioning of PLL and semi-permanent D-channel services (refer to subclauses 11.4 and 11.5) is for further study.

## History

Document history	
August 1992	First Edition
September 1996	Public Enquiry PE 114: 1996-09-23 to 1997-01-17