



AMENDMENT

ETS 300 086

A2

March 1997

Source: ETSI TC-RES

Reference: RE/RES-02025

ICS: 33.020

Key words: Mobile, radio, speech, testing

**This amendment A2 modifies
the European Telecommunication Standard ETS 300 086 (1991)**

**Radio Equipment and Systems (RES);
Land mobile group;
Technical characteristics and test conditions for radio
equipment with an internal or external RF connector
intended primarily for analogue speech**

ETSI

European Telecommunications Standards Institute

ETSI Secretariat

Postal address: F-06921 Sophia Antipolis CEDEX - FRANCE

Office address: 650 Route des Lucioles - Sophia Antipolis - Valbonne - FRANCE

X.400: c=fr, a=atlas, p=etsi, s=secretariat - **Internet:** secretariat@etsi.fr

Tel.: +33 4 92 94 42 00 - Fax: +33 4 93 65 47 16

Copyright Notification: No part may be reproduced except as authorized by written permission. The copyright and the foregoing restriction extend to reproduction in all media.

© European Telecommunications Standards Institute 1997. All rights reserved.

Foreword

This amendment to ETS 300 086 (1991) has been produced by the Radio Equipment and Systems (RES) Technical Committee of the European Telecommunications Standards Institute (ETSI).

ETS 300 086 as amended by this amendment, together with ETS 300 279 is intended to become a Harmonized Standard the reference of which is intended to be published in the Official Journal of the European Communities, referencing Council Directive 89/336/EEC (EMC Directive).

Annex E contains the ERC Decision which references the technical specifications in this ETS for inclusion in national approval regulations.

Transposition dates	
Date of adoption:	21 February 1997
Date of latest announcement of this ETS (doa):	30 June 1997
Date of latest publication of new National Standard or endorsement of this ETS (dop/e):	31 December 1997
Date of withdrawal of any conflicting National Standard (dow):	31 December 1997

Amendments

Page 7, Foreword

Replace the first paragraph with the following:

This European Telecommunication Standard (ETS) has been prepared by the Radio Equipment and Systems (RES) Technical Committee of the European Telecommunications Standards Institute (ETSI).

This ETS, together with ETS 300 279 is intended to become a Harmonized Standard the reference of which is intended to be published in the Official Journal of the European Communities, referencing Council Directive 89/336/EEC (EMC Directive).

Replace third paragraph with:

Angle modulation is used for radio equipment covered by this ETS, but individual national administrations are free to choose the type of modulation. Channel separations, maximum transmitter output power / effective radiated power, class of transmitter intermodulation attenuation and the inclusion of automatic transmitter shut-off facility may all be conditions relating to the issue of a licence by the appropriate administration.

Insert the following after the last paragraph:

The technical specifications which are relevant to the EMC Directive are listed in annex D.

Annex E contains the ERC Decision (ERC/DEC/(95)02), dated 1995, which references the technical specifications in ETS 300 086 for inclusion in national type approval regulations.

Page 23, subclause 5.4.1

Replace entire subclause with:

For tests at extreme temperatures, measurements shall be made in accordance with the procedures specified in subclause 5.5, at the upper and lower temperatures of the following range:

-20 °C to + 55 °C.

For the purpose of note (a) to table 1 in subclause 4.1.1, an additional reduced extreme temperature range of 0 °C to + 30 °C shall be used when appropriate.

Type test reports shall state the temperature range used.

Page 32, subclause 7.7.2

Replace figure 2 with:

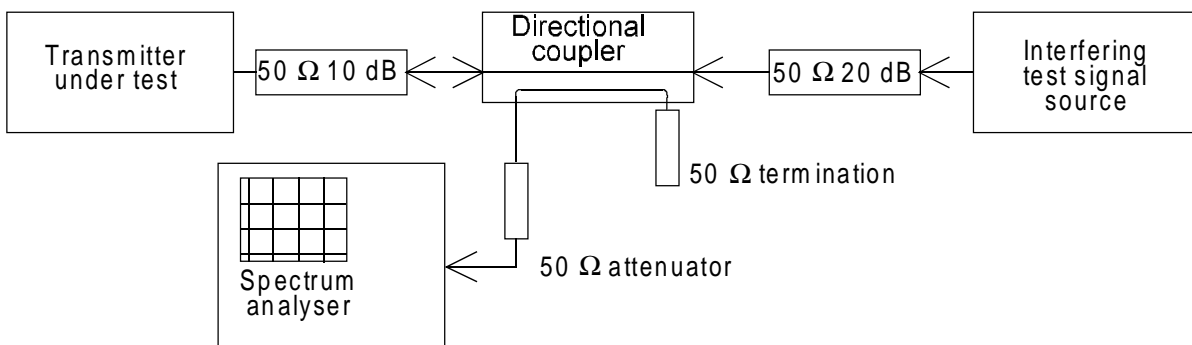

Figure 2: Measurement arrangement

Page 58

Insert the following before History:

Annex D (normative): ETS 300 086 Radio Equipment and Systems (RES); Land mobile group; Technical characteristics and test conditions for radio equipment with an internal or external RF connector intended primarily for analogue speech

Table D.1: Clauses and/or subclauses of this ETS relevant for compliance with essential requirements of the EC Council Directives

Clause/subclause number and title		Corresponding article of Council Directive 89/336/EEC	Qualifying remarks
4.1.6	Spurious emissions	4(a)	
4.2.9	Spurious radiations	4(a)	
4.2.6	Spurious response rejection	4(b)	
4.2.8	Blocking or desensitisation	4(b)	

Annex E (normative): **ERC Decision of 1st December 1995 on the adoption of national type approval regulations for equipment to be used in the land mobile service using angle modulation based on the European Telecommunications Standard (ETS) 300 086 (ERC/DEC/(95)02)**

This annex contains the ERC Decision (ERC/DEC/(95)02), dated 1995, which references the technical specifications in ETS 300 086 [2] for inclusion in national type approval regulations.

EUROPEAN RADIOCOMMUNICATIONS COMMITTEE

ERC Decision
of 1st December 1995
on the adoption of national type approval regulations for
equipment to be used in
the land mobile service using angle modulation
based on the European Telecommunications Standard
(ETS) 300 086
(ERC/DEC/(95)02)

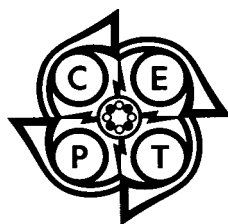

EXPLANATORY MEMORANDUM

1. INTRODUCTION

The free movement of radiocommunications goods and the provision of Europe-wide services for radiocommunications are only achievable if there exist common regulations throughout Europe regarding availability of frequency bands, type approval requirements and border crossing procedures. A basic requirement to fulfil these objectives is the Europe-wide implementation of national regulations based on the European Telecommunications Standards (ETSS) developed by the European Telecommunications Standards Institute (ETSI).

This Decision (ERC/DEC/(95)02) provides the necessary mechanism for CEPT administrations to commit themselves to implement, within their national regimes, European Telecommunications Standard 300 086¹ and withdraw any conflicting national standard.

2. BACKGROUND

Both the ERC and ETSI are involved in the development of common regulations, as described in (1) above. The Memorandum of Understanding between ERC and ETSI explains the respective responsibilities of the two organisations and its annex describes the principles of cooperation. The ERC, for its part, should, *inter alia*, adopt Decisions on the introduction of ETSI standards into national type approval regimes.

ETS 300 086 has been prepared by the Radio Equipment and Systems (RES) Technical Committee of ETSI. The standard has undergone the ETSI standards approval procedure and is now published as an ETS.

The ETS, which is based on CEPT Recommendation T/R 24-01, is a general standard which may be superseded by specific standards covering specific applications.

The use of the frequency range (30-1000 MHz) covered by ETS 300 086 is not harmonised within CEPT. Although CEPT Recommendation T/R 25-08 provides preferred arrangements for some frequency bands designated for mobile radio systems, Administrations have adopted different arrangements, to meet national requirements, for frequency bands, duplex separations and channel separations (12.5, 20 and 25 kHz). Further, the equipment used in this frequency range is subject to national licensing and frequency planning which requires specification of, *inter alia*, frequency of operation and effective radiated power (e.r.p.) and, in some cases, additional requirements to improve spectrum utilisation, for example timers to limit maximum duration of transmissions. Such parameters of requirements are considered as outside the scope of this Decision.

Nevertheless, there are a number of parameters, in particular those considered by the ERC as essential for spectrum management purposes, which can be harmonised by adopting within national type approval regulations the limit values and measurement methods provided in ETS 300 086.

3. REQUIREMENTS FOR AN ERC DECISION

The allocation and assignment of radio frequencies and the complementary equipment type approval regimes in CEPT member countries are laid down by law, regulation or administrative action. The ERC recognises that for harmonised fixed and mobile radio services to be introduced successfully throughout Europe, manufacturers and operators must be given the confidence to make the necessary investment in the development and procurement of new systems. Commitment by CEPT administrations to implement this ERC Decision will provide a clear indication that equipment conforming to national type approval regulations based on ETS 300 086 will have the benefit of a Europe-wide market.

¹ ETS 300 086: "Technical characteristics and test conditions for radio equipment with an internal or external RF connector intended primarily for analogue speech."

**ERC Decision
of 1st December 1995**

**on the adoption of national type approval regulations
for equipment to be used in the land mobile service using angle modulation
based on the European Telecommunications Standard (ETS) 300 086**

The European Conference of Postal and Telecommunications Administrations,

considering:

- a) that CEPT has a long term objective to harmonise the use of frequencies and the related regulatory regimes,
- b) that such harmonisation will benefit administrations, manufacturers, operators and users,
- c) that ETSI has published ETS 300 086 for equipment to be used in the land mobile service operating on radio frequencies between 30 MHz and 1000 MHz with channel separations of 12.5 kHz, 20 kHz and 25 kHz and intended primarily for analogue speech,
- d) that, for the foreseeable future, many official, public and private networks will continue to use land mobile equipment having the technical characteristics described in c) above,
- e) that, in accordance with the Memorandum of Understanding between ERC and ETSI, the ERC shall adopt ERC Decisions on the introduction of ETSI standards into national type approval regimes,
- f) that the use of radio equipment is subject to national licensing and frequency planning requirements, in particular for frequency of operation, limit of maximum duration of transmission (e.g. use of time-out/timers) and e.r.p.,
- g) that suitable transitional arrangements are given in CEPT Recommendation T/R 01-05,

DECIDES

1. to adopt, by 1 April 1996, national type approval regulations for equipment to be used in the land mobile service using angle modulation, based on the limit values and measurement methods for spectrum management parameters² contained in ETS 300 086, with the exception of those parameters which are subject to national licensing requirements,
2. to withdraw any conflicting national regulation(s),
3. that CEPT Member administrations shall communicate the national measures implementing this Decision to the ERC Chairman and the ERO when the Decision is nationally implemented.

² Annex 1 contains parameters from ETS 300 086 to be included in national type approval regulations. Annex 2 is provided for information to show which options have been adopted by each Administration in those cases where ETS 300 086 offers a choice.

ANNEX 1

Parameters of ETS 300 086¹ to be included in national type approval regulations

ETS 300 086	Section	Comments
Transmitters parameter limits	4.1	
Frequency error	4.1.1	
Carrier power variation (conducted)	4.1.2	Subject to national licensing conditions
Effective radiated power	4.1.3	Subject to national licensing conditions
Frequency deviation	4.1.4	Options for channel spacings 12.5, 20 and 25 kHz ³
Adjacent channel power	4.1.5	Options for channel spacings 12.5 and 20/25 kHz ³
Spurious emissions	4.1.6	
Intermodulation attenuation	4.1.7	Site engineering conditions may be imposed by licensing
Transient frequency behaviour of a transmitter	4.1.8	
Receiver parameters	4.2	
Maximum usable sensitivity	4.2.1	

¹ See page 1

³ See Annex 2 for details of the national implementation of channel spacing and temperature range options

Maximum usable sensitivity (field strength)	4.2.2	Split into frequency bands
Amplitude characteristic	4.2.3	
Co-channel rejection	4.2.4	Options for channel spacings 12.5 and 20/25 kHz ³
Adjacent channel selectivity	4.2.5	Options for channel spacings 12.5 and 20/25 kHz ³
Spurious response rejection	4.2.6	
Intermodulation response rejection	4.2.7	
Blocking or desensitisation	4.2.8	
Spurious radiations	4.2.9	
Duplex operation - receiver limits	4.3	
Receiver desensitisation and maximum usable sensitivity	4.3.1	
Receiver spurious response rejection	4.3.2	

³ See Annex 2 for details of the national implementation of channel spacing and temperature range options

ANNEX 2 (informative)

Adoption of ETS 300 086: National variations for channel spacing and temperature range.

Administration	Adoption of channel spacing options	Adoption of temperature range options
Albania		
Austria		
Belgium		
Bosnia and Herzegovina		
Bulgaria		
Croatia	V1, U1	3
Cyprus		
Czech Republic		
Denmark		
Estonia		
Finland	V3, U3 (mainly used), V1, U1	1 (mobiles/portables), 3 (base stations)
Former Yugoslav Republic of Macedonia		
France		
Germany		
Greece		
Hungary		
Iceland	V3, U3	2
Ireland		
Italy		
Latvia		
Liechtenstein		
Lithuania		
Luxembourg		
Malta		
Moldova		
Monaco		
Netherlands		

Norway		
Poland		
Portugal	V1, V2, U1	3
Romania		
Russian Federation		
San Marino		
Slovak Republic		
Slovenia		
Spain		
Sweden	V3, U3, (V1 and U1 allowed)	1
Switzerland		
Turkey		
Ukraine		
United Kingdom		
Vatican City		

Key: Channel spacing options:

U= UHF 1 = 12.5 kHz
V=VHF 2 = 20 kHz
 3 = 25 kHz

Temperature range options

1 = -25 to +55°C
2 = -15 to +55°C
3 = -10 to +55°C

European Radiocommunications Committee Decision

CEPT ERC/DEC/(95)02

On the adoption of national type approval regulations for equipment to be used in the land mobile service using angle modulation based on the European Telecommunications Standard (ETS) 300 086

As of 18 April 1996 the following CEPT Members have committed themselves to apply the terms of this Decision:

Austria
Belgium
Croatia
Denmark
Finland
France
Germany
Iceland
Ireland
Liechtenstein
Netherlands
Norway
Portugal
Sweden
Switzerland
Turkey
United Kingdom

History

Document history	
January 1991	First Edition
October 1996	Unified Approval Procedure UAP 56: 1996-10-21 to 1997-02-14
March 1997	Amendment 2 to Edition 1 (including prior Amendments)