



EUROPEAN
TELECOMMUNICATION
STANDARD

ETS 300 058-1

October 1991

Source: ETSI TC-SPS

Reference: T/S 46-33F

ICS: 33.080

Key words: ISDN, supplementary service

**Integrated Services Digital Network (ISDN);
Call Waiting (CW) supplementary service;
Digital subscriber Signalling System No. one (DSS1) protocol;
Part 1: Protocol specification**

ETSI

European Telecommunications Standards Institute

ETSI Secretariat

Postal address: F-06921 Sophia Antipolis CEDEX - FRANCE

Office address: 650 Route des Lucioles - Sophia Antipolis - Valbonne - FRANCE

X.400: c=fr, a=atlas, p=etsi, s=secretariat - **Internet:** secretariat@etsi.fr

Tel.: +33 92 94 42 00 - Fax: +33 93 65 47 16

Copyright Notification: No part may be reproduced except as authorized by written permission. The copyright and the foregoing restriction extend to reproduction in all media.

© European Telecommunications Standards Institute 1991. All rights reserved.

Contents

Foreword	5
1 Scope	7
2 Normative references	7
3 Definitions.....	8
4 Symbols and abbreviations.....	9
5 Description	9
6 Operational requirements.....	9
6.1 Provision and withdrawal	9
6.2 Requirements on the originating network side.....	9
6.3 Requirements on the destination network side.....	9
7 Coding requirements.....	9
8 State definitions	9
9 Signalling procedures at the coincident S and T reference point	10
9.1 Activation.....	10
9.2 Deactivation.....	10
9.3 Registration	10
9.4 Call offering.....	10
9.4.1 Normal operation.....	10
9.4.2 Exceptional procedures.....	10
9.5 Call confirmation	10
9.5.1 Normal operation.....	10
9.5.1.1 Network determined user busy	10
9.5.1.2 Subscriber resources in use	11
9.5.2 Exceptional procedures.....	11
9.6 Call waiting acceptance	11
9.6.1 Normal operation.....	11
9.6.2 Exceptional procedures.....	12
10 Procedures for interworking with private ISDNs	13
10.1 Served user is on a private ISDN.....	13
10.2 Calling user is on a private ISDN	13
11 Interaction with other networks.....	13
12 Interaction with other supplementary services.....	13
13 Parameter values	13
14 Dynamic description (SDLs)	13
Annex A (Informative): Signalling flows	14
History	19

Blank page

Foreword

This European Telecommunication Standard (ETS) has been produced by the Signalling Protocols and Switching (SPS) Technical Committee of the European Telecommunications Standards Institute (ETSI).

This ETS is part 1 of a multi-part standard covering the Digital Subscriber Signalling System No. one (DSS1) protocol specification for the Integrated Services Digital Network (ISDN) Call Waiting (CW) supplementary service, as described below:

- Part 1: "Protocol specification";**
- Part 2: "Protocol Implementation Conformance Statement (PICS) proforma specification";
- Part 3: "Test Suite Structure and Test Purposes (TSS&TP) specification for the user";
- Part 4: "Abstract Test Suite (ATS) and partial Protocol Implementation eXtra Information for Testing (PIXIT) proforma specification for the user";
- Part 5: "TSS&TP specification for the network";
- Part 6: "ATS and partial PIXIT proforma specification for the network".

In accordance with CCITT Recommendation I.130, the following three level structure is used to describe the supplementary telecommunications services as provided by European public telecommunications operators under the pan-European Integrated Services Digital Network (ISDN):

- Stage 1: is an overall service description, from the user's standpoint;
- Stage 2: identifies the functional capabilities and information flows needed to support the service described in stage 1; and
- Stage 3: defines the signalling system protocols and switching functions needed to implement the service described in stage 1.

This ETS details the stage 3 aspects (signalling system protocols and switching functions) needed to support the Call Waiting (CW) supplementary service. The stage 1 and stage 2 aspects are detailed in ETS 300 056 (1991) and ETS 300 057 (1991), respectively.

This reprint includes all previous Corrigenda as shown in the History box at the last page.

Blank page

1 Scope

This first part of ETS 300 058 specifies the stage three of the Call Waiting (CW) supplementary service for the Pan-European Integrated Services Digital Network (ISDN) as provided by European public telecommunications operators at the T reference point or coincident S and T reference point (as defined in CCITT Recommendation I.411 [1]) by means of the Digital Subscriber Signalling System No. one (DSS1). Stage 3 identifies the protocol procedures and switching functions needed to support a telecommunications service (see CCITT Recommendation I.130 [2]).

In addition this standard specifies the protocol requirements at the T reference point where the service is provided to the user via a private ISDN.

This standard does not specify the additional protocol requirements where the service is provided to the user via a telecommunications network that is not an ISDN.

The CW supplementary service permits a user to be informed of an incoming call (as per basic call procedures) with an indication that no interface information channel is available. The user has then the choice of accepting, rejecting or ignoring the waiting call (as per basic call procedures).

The CW supplementary service is considered meaningful when applied to the telephony teleservice and the speech and 3,1 kHz audio bearer services. Furthermore, it can be applied to other circuit-switched services.

Further parts of this standard specify the method of testing required to identify conformance to this standard.

This standard is applicable to equipment supporting the CW supplementary service, to be attached at either side of a T reference point or coincident S and T reference point when used as an access to the public ISDN.

2 Normative references

This ETS incorporates by dated or undated reference, provisions from other publications. These normative references are cited at the appropriate places in the text and the publications listed hereafter. For dated references, subsequent amendments to, or revisions of any of these publications apply to this ETS only when incorporated in it by amendment or revision. For undated references the latest edition of the publication referred to applies.

- [1] CCITT Recommendation I.411 (1988): "ISDN user-network interfaces - Reference configurations".
- [2] CCITT Recommendation I.130 (1988): "Method for the characterisation of telecommunication services supported by an ISDN and network capabilities of an ISDN".
- [3] ETS 300 196-1: "Integrated Services Digital Network (ISDN); Generic functional protocol for the support of supplementary services; Digital Subscriber Signalling System No. one (DSS1) protocol; Part 1: Protocol specification".
- [4] ETS 300 102-1 (1990): "Integrated Services Digital Network (ISDN); User-network interface layer 3; Specifications for basic call control".
- [5] ETS 300 195-1: "Integrated Services Digital Network (ISDN); Supplementary service interactions; Digital Subscriber Signalling System No. one (DSS1) protocol; Part 1: Protocol specification".
- [6] ETS 300 102-2 (1990): "Integrated Services Digital Network (ISDN); User-network interface layer 3; Specification for basic call control; Specification Description Language (SDL) diagrams".

- [7] CCITT Recommendation I.112 (1988): "Vocabulary of terms for ISDNs".
- [8] CCITT Recommendation I.221 (1988): "Common specific characteristics of services".
- [9] CCITT Recommendation I.210 (1988): "Principles of telecommunication services supported by an ISDN and the means to describe them".
- [10] ETS 300 141: "Integrated Services Digital Network (ISDN); Call Hold (HOLD) supplementary service; Digital Subscriber Signalling System No. one (DSS1) protocol".

3 Definitions

For the purposes of this standard, the following definitions apply:

Integrated Services Digital Network (ISDN): see CCITT Recommendation I.112 [7], § 2.3, definition 308.

Service; telecommunications service: see CCITT Recommendation I.112 [7], § 2.2, definition 201.

Supplementary service: see CCITT Recommendation I.210 [9], § 2.4.

User: the DSS1 protocol entity at the user side of the user-network interface.

Network: the DSS1 protocol entity at the network side of the user-network interface.

Channels busy: see CCITT Recommendation I.221 [8], § 3.1.3.

Network determined user busy: see CCITT Recommendation I.221 [8], §§ 3.1.4.

Information channel control: a user having information channel control is a user in one of the following states : Overlap Sending (U2); Outgoing Call Proceeding (U3); Call Delivered (U4); Call Received (U7)(Note); Connect Request (U8)(Note); Incoming Call Proceeding (U9)(Note); Active (U10); Disconnect Request (U11); Disconnect Indication (U12); Release Request (U19).

NOTE : Applicable only if a point-to-point configuration exists.

Subscriber B: subscriber B is the subscriber who is provided by the network with the CW supplementary service on a particular interface.

User A: user A is a user who is engaged in a call with user B.

User B: user B is the user who reacts to the call waiting at subscriber B.

User C: user C is the user who has originated a call to subscriber B which causes the CW supplementary service to be invoked.

4 Symbols and abbreviations

CW	Call Waiting
DSS1	Digital Subscriber Signalling System No. one
ISDN	Integrated Services Digital Network

5 Description

The CW supplementary service allows notification to subscriber B of the incoming call.

The CW supplementary service shall operate when all appropriate B-channels of the access to the terminals of subscriber B are busy. When at least one B-channel is free, any user B who is compatible and busy can respond to an incoming call according to the procedures of ETS 300 102-1 [4], subclause 5.2.

The network shall not provide audible in-band tone to subscriber B, but the terminals of subscriber B may generate locally an audible in-band indication.

6 Operational requirements

6.1 Provision and withdrawal

This service may be provided by prior arrangement with the administration, or may be available on a general basis.

Withdrawal shall be at the request of the customer or for administrative reasons.

6.2 Requirements on the originating network side

Not applicable.

6.3 Requirements on the destination network side

Not applicable.

7 Coding requirements

The notification to the calling party shall be included in the Notification indicator information element specified in ETS 300 102-1 [4], subclause 4.5.21. It shall be coded as shown in table 1.

Table 1

bits							Meaning
7	6	5	4	3	2	1	
1	1	0	0	0	0	0	Call is a waiting call

8 State definitions

The states associated with basic call control according to ETS 300 102-1 [4] shall apply.

9 Signalling procedures at the coincident S and T reference point

9.1 Activation

NOTE: Activation is a local procedure on the terminal side and does not require any user-to-network procedure.

9.2 Deactivation

NOTE: Deactivation is a local procedure on the terminal side and does not require any user-to-network procedure.

9.3 Registration

Not applicable.

9.4 Call offering

9.4.1 Normal operation

When an incoming call from user C arrives at the access of subscriber B and encounters the channels busy condition and a network determined user busy condition does not result, then the call shall be offered to subscriber B.

In that case, the SETUP message shall be the SETUP message used in the establishment of an incoming call (as described in subclause 5.2.1 of ETS 300 102-1 [4]) indicating "no channel" in the information channel selection field of the Channel identification information element, the bit "preferred/exclusive" being set to "indicated channel is preferred".

If a B-channel is available, the call shall be offered to subscriber B in accordance with subclause 5.2.1 and subclause 5.2.3 of ETS 300 102-1 [4].

9.4.2 Exceptional procedures

Not applicable.

9.5 Call confirmation

9.5.1 Normal operation

The busy users that have information channel control and are compatible with the incoming call can proceed with the call. Those users shall respond by sending an ALERTING message to the network, possibly following a SETUP ACKNOWLEDGE or a CALL PROCEEDING message, in accordance with subclause 5.2.5.1 of ETS 300 102-1 [4].

The action to be taken by the network on receipt of the ALERTING message shall be the same as for basic call control procedures (see subclause 5.2.5.2 of ETS 300 102-1 [4]).

9.5.1.1 Network determined user busy

If the call has been offered with the "no B-channel condition", timer T-CW may be started instead of timer T301.

The use of timer T-CW is a network option. If used, timer T-CW replaces the basic call timer T301.

The user shall not return the Channel identification information element in the SETUP ACKNOWLEDGE, CALL PROCEEDING or ALERTING message.

Depending on the subscription options of user B offered by the network, some networks may include a Notification indicator information element in the ALERTING message sent to the calling party.

9.5.1.2 Subscriber resources in use

If the call was offered with an available B-channel (according to the procedures of subclause 5.2.1 and subclause 5.2.3 of ETS 300 102-1 [4], but resources to complete the call are in use in the terminal, the user may start timer T-CW, if implemented.

9.5.2 Exceptional procedures

In the case where the busy users are compatible with the incoming call but are not able to proceed with the call, the user shall respond by sending a RELEASE COMPLETE message, specifying cause #17 "user busy", in accordance with subclause 5.2.5.1 of ETS 300 102-1 [4].

In the case where the call was offered with a no B-channel indication, the free users which are compatible with the incoming call shall respond by sending a RELEASE COMPLETE message to the network, specifying cause #34 "no circuit/channel available", in accordance with subclause 5.2.3 of ETS 300 102-1 [4].

In the case where the network does not receive any response to the retransmitted SETUP message prior to the expiration of timer T303, then the network shall initiate clearing procedures in accordance with subclause 5.2.5.4 of ETS 300 102-1 [4].

If the SETUP message contained a Channel identification information element coded with "no B-channel" and if the user proceeds with the call, and if it returns the Channel identification information element in the SETUP ACKNOWLEDGE, CALL PROCEEDING or ALERTING message, then the Channel identification information element shall be ignored by the network.

If timer T-CW is running in the network, and timer T-CW expires, the call shall be cleared towards the calling user according to the procedures of subclause 5.2.5.4 of ETS 300 102-1 [4] with a cause value #19 "no answer from user (user alerted)". The call shall be cleared towards the served user according to the procedures of subclause 5.2.5.4 of ETS 300 102-1 [4] with a cause value #102 "recovery on timer expiry" included in the RELEASE message.

If timer T-CW is running at the user side, and timer T-CW expires, the user shall clear the call according to the procedures of subclause 5.3.3 of ETS 300 102-1 [4] with cause value #19 "no answer from user (user alerted)" included in the DISCONNECT message.

9.6 Call waiting acceptance

9.6.1 Normal operation

User B can free resources to accept a waiting call by:

- a) releasing an existing call according to the procedures of ETS 300 102-1 [4] subclause 5.3;
- b) using the call hold supplementary service on an existing call according to the procedures of ETS 300 141 [10].

NOTE: See figure A.1 and figure A.2.

To accept the waiting call, the procedures of ETS 300 102-1 [4] subclause 5.2.7, subclause 5.2.8 and subclause 5.2.9 shall apply with the following exceptions:

- a) on receipt of the CONNECT message the network shall stop timer T-CW, if implemented instead of timer T301;
- b) if "no channel" was indicated in the information channel selection field of the Channel identification information element included in the SETUP message, then the network shall indicate the B-channel to be used by inclusion of a Channel identification information element coded as "channel is indicated, no alternative acceptable" in the CONNECT ACKNOWLEDGE message. In accordance with the procedures of ETS 300 102-1 [4] subclause 5.2.3, the user may request a specific channel by including a Channel identification information element coded as "channel is indicated, no alternative acceptable" in the CONNECT message.

It is recommended that this option is used only on point-to-point configurations and where the user also uses that coding of the Channel identification information element in a SETUP message on an outgoing call request (see ETS 300 102-1 [4] subclause 5.1.2);

- c) if resources are freed using the call hold supplementary service, then the procedures of the Reservation function shall be used as defined in ETS 300 196-1 [3] to use any reservation.

9.6.2 Exceptional procedures

After the ALERTING message has been sent by the user, this new incoming call can be rejected by user B by sending a DISCONNECT message with the call reference associated with the waiting call. The network shall handle the receipt of the DISCONNECT message in accordance with subclause 5.3.3 and subclause 5.2.5.3 of ETS 300 102-1 [4], respectively for the calling and the called users.

NOTE 1: See figure A.3.

After the ALERTING message has been sent by user B, the user can decide not to react to this new call (neither accepting nor rejecting the call). When timer T301 or T-CW, if implemented, expires, then the network shall initiate clearing procedures in accordance with subclause 5.2.5.4 of ETS 300 102-1 [4].

NOTE 2: See figure A.4.

If calling user C clears the call attempt before the call has been established, then the network shall initiate clearing of the waiting call in accordance with subclause 5.3.4 of ETS 300 102-1 [4].

On receipt of a CONNECT message sent by user B and if no B-channel is available to complete the call (i.e. no channel is free and no channel is reserved for use by this terminal), then the network shall clear the user by sending a RELEASE message in accordance with subclause 5.3 of ETS 300 102-1 [4] with cause value #44 "requested circuit/channel not available".

If the user returns the Channel identification information element in the CONNECT message indicating "channel is indicated, no alternative acceptable" and if the network cannot accept the indicated B-channel, it shall clear the user by sending a RELEASE message in accordance with subclause 5.3 of ETS 300 102-1 [4] with cause value #44 "Requested circuit/channel not available".

10 Procedures for interworking with private ISDNs

10.1 Served user is on a private ISDN

The private ISDN shall inform the public network, where applicable, of a waiting call at its S reference point by means of a "call waiting" notification according to the procedures of ETS 300 196-1 [3], carried in an ALERTING message.

The public network shall forward this notification to user C independently of subscription to the CW supplementary service.

NOTE: During an interim period of time some networks may not support the sending of the notification to the remote user.

10.2 Calling user is on a private ISDN

The public network may include a Notification indicator information element in the ALERTING message sent to the user.

11 Interaction with other networks

Not applicable.

12 Interaction with other supplementary services

The interactions of the CW supplementary service with other supplementary services shall be as specified in ETS 300 195-1 [5].

13 Parameter values

Timer T303 associated with basic call control according to ETS 300 102-1 [4] shall apply.

NOTE: Timer T303 is identified in the stage one service description by T1.

The use of timer T-CW is a network option. When used, the value of timer T-CW shall be set by the network as a default value subject to change only by the network.

Alternatively to timer T-CW, timer T301 associated with basic call control according to ETS 300 102-1 [4] may be used.

14 Dynamic description (SDLs)

ETS 300 102-2 [6] shall apply, with the exception that timer T301 shall be replaced by timer T-CW, if implemented, when the SETUP message is sent with a "no-channel" condition.

Annex A (Informative): Signalling flows

The signalling flows for the CW supplementary service are shown as follows:

- Figure A.1 (Waiting call acceptance. No B-channel available);
- Figure A.2 (Waiting call acceptance. B-channel available);
- Figure A.3 (Call waiting rejection); and
- Figure A.4 (Call waiting ignored. No B-channel available).

All these figures assume that the three terminals are compatible with the requested characteristics of the call with call reference 3.

These figures do not reflect all the information elements described in the basic call control (see ETS 300 102-1 [4]). They are only examples describing the operation of call waiting in a point to multipoint situation.

Key to figure A.1, figure A.2, figure A.3 and figure A.4.

TE1, TE2, TE3	Terminal equipments on User B's access.
B1, B2	Two different channels on User B's access.
CR1, CR2, CR3	Three different calls active or presented at User B's access.
CW	(in ALERTING) notification of call waiting.

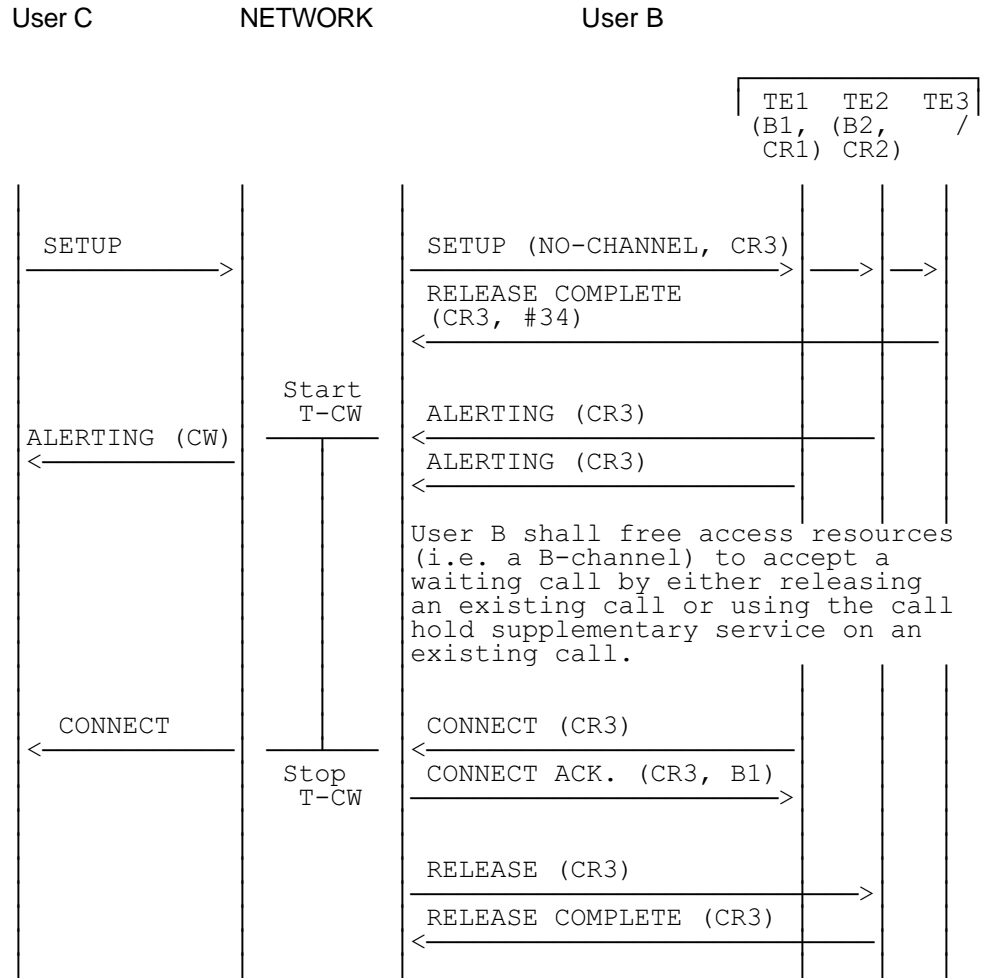

Figure A.1: Waiting call acceptance. No B-channel available

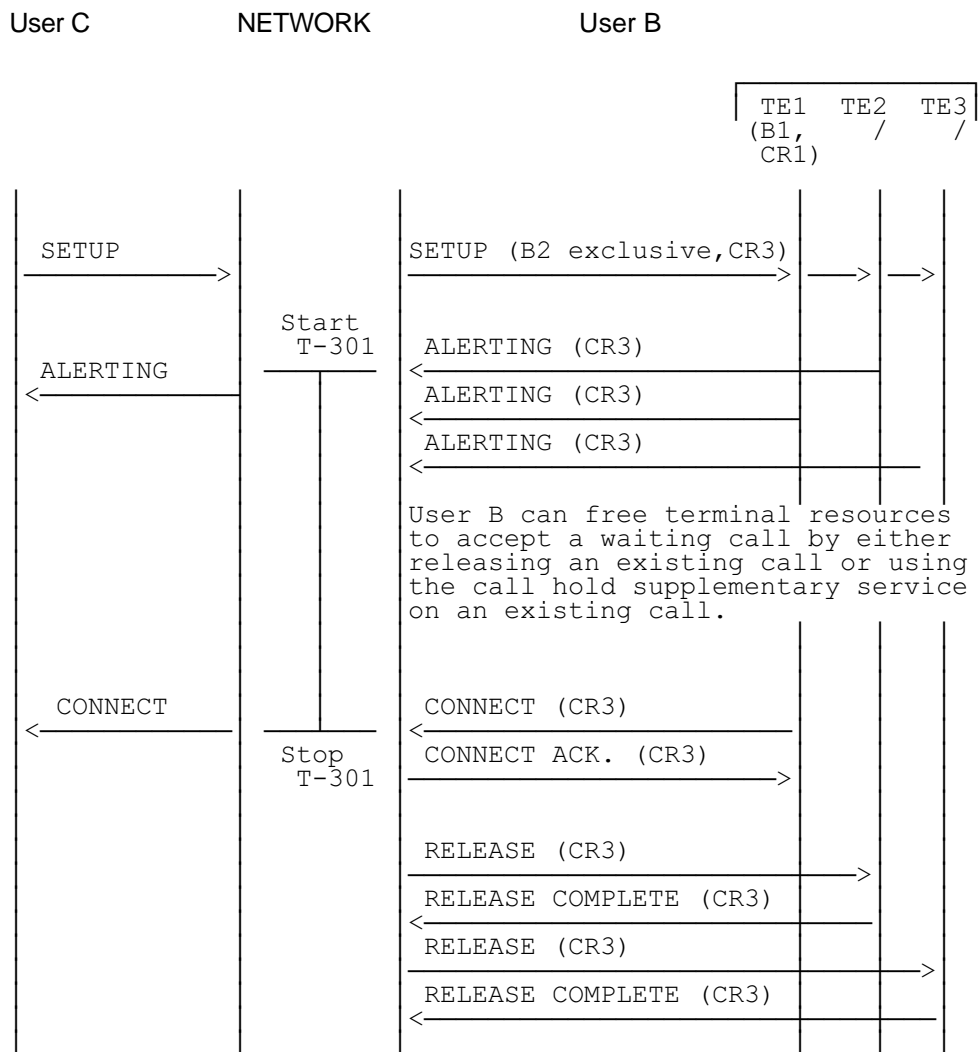

Figure A.2: Waiting call acceptance. B-channel available

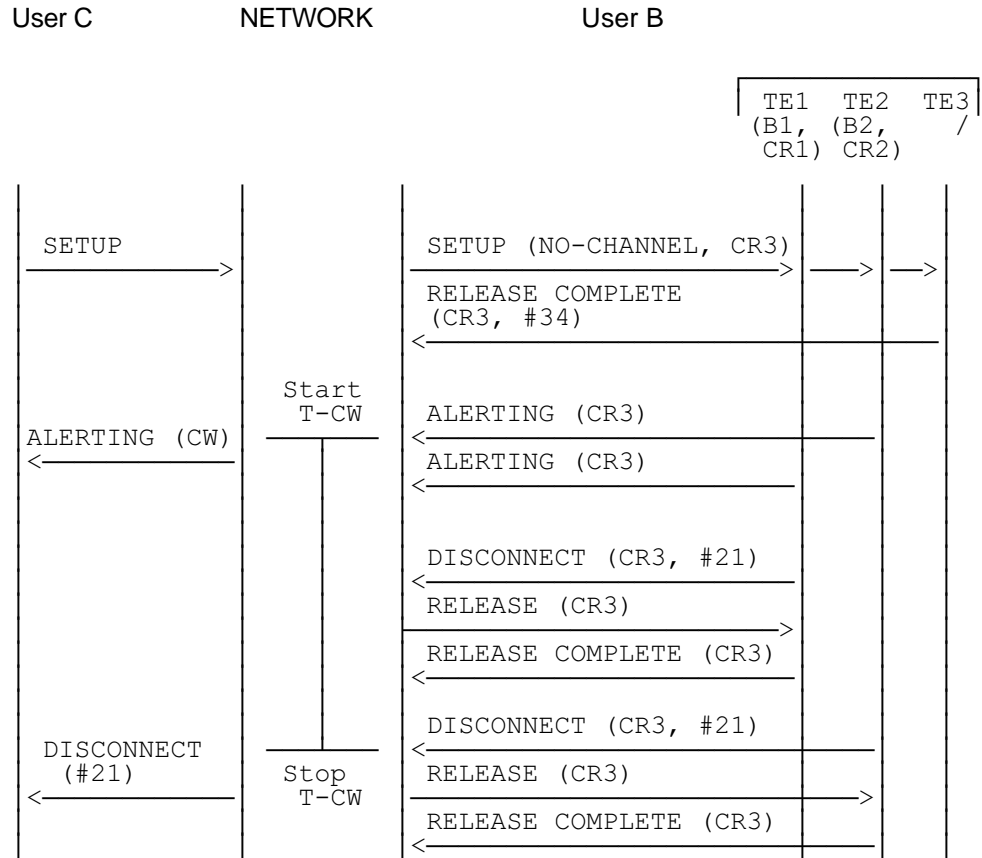

Figure A.3: Call waiting rejection

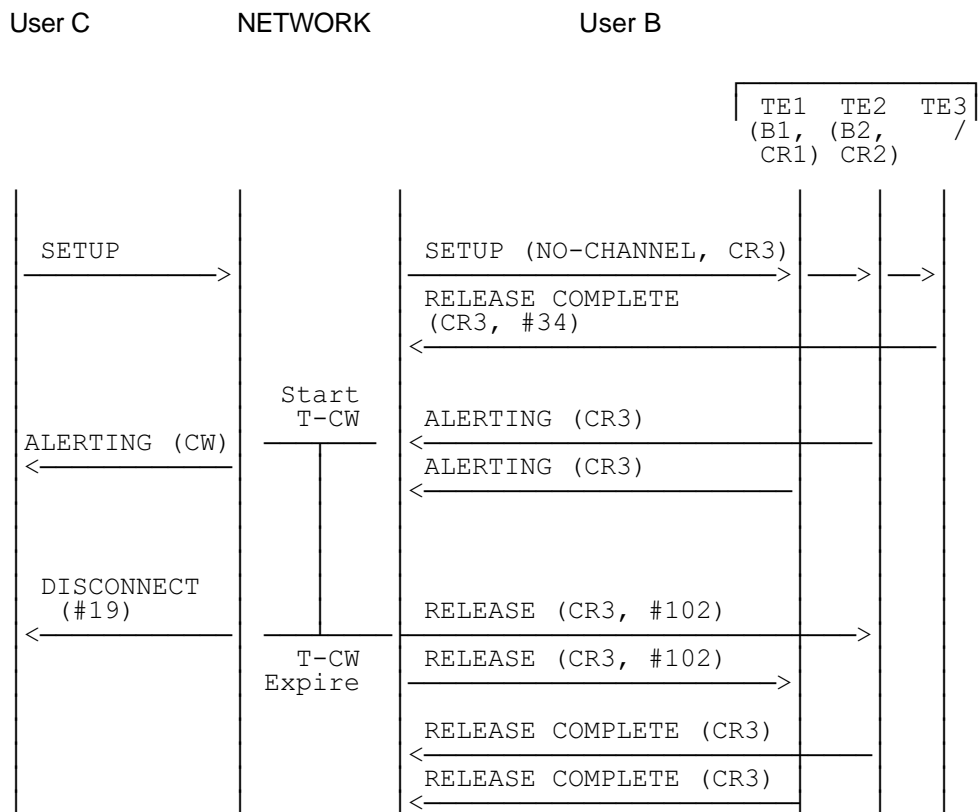

Figure A.4: Call waiting ignored. No B-channel available

History

Document history	
October 1991	First Edition
April 1994	Corrigendum to First Edition: change to part 1 of a multi-part standard
March 1996	Converted into Adobe Acrobat Portable Document Format (PDF) and incorporation of all prior Corrigenda