

EUROPEAN
TELECOMMUNICATION
STANDARD

ETS 300 047-4

August 1992

Source: ETSI TC-TE

Reference: T/TE 04-35

ICS: 33.080

Key words: ISDN, basic access, safety, protection

**Integrated Services Digital Network (ISDN);
Basic access - safety and protection
Part 4: Interface I_b - safety**

ETSI

European Telecommunications Standards Institute

ETSI Secretariat

Postal address: F-06921 Sophia Antipolis CEDEX - FRANCE

Office address: 650 Route des Lucioles - Sophia Antipolis - Valbonne - FRANCE

X.400: c=fr, a=atlas, p=etsi, s=secretariat - **Internet:** secretariat@etsi.fr

Tel.: +33 92 94 42 00 - Fax: +33 93 65 47 16

Copyright Notification: No part may be reproduced except as authorized by written permission. The copyright and the foregoing restriction extend to reproduction in all media.

© European Telecommunications Standards Institute 1992. All rights reserved.

Contents

Foreword.....	5
1 Scope	7
2 Normative references	7
3 Definitions and abbreviations	7
3.1 Definitions	7
3.2 Abbreviations	7
4 Reference configuration	7
5 Safety requirements and tests.....	7
5.1 General	7
5.2 Test conditions.....	8
5.3 Touch current.....	8
5.3.1 Equipment without auxiliary interfaces	9
5.3.2 Equipment with auxiliary interfaces	9
Annex A (normative):	12
Connection of PE conductor for equipment with multiple interfaces	12
History.....	13

Blank page

Foreword

This European Telecommunication Standard (ETS) has been produced by the Terminal Equipment (TE) Technical Committee of the European Telecommunications Standards Institute (ETSI) in collaboration with members of the Business Telecommunications (BT) and Transmission and Multiplexing (TM) Technical Committees.

This ETS aims to meet the urgent requirements of network operators and equipment manufacturers who are designing equipment to operate with the Integrated Services Digital Network (ISDN) basic access interface.

This is the fourth part of a multipart ETS which comprises the following:

ETS 300 047: "Integrated Services Digital Network (ISDN); Basic access - safety and protection".

ETS 300 047-1 (Part 1): General.

ETS 300 047-2 (Part 2): Interface I_a - safety.

ETS 300 047-3 (Part 3): Interface I_a - protection.

ETS 300 047-4 (Part 4): Interface I_b - safety.

ETS 300 047-5 (Part 5): Interface I_b - protection.

Parts 2 to 5 of this ETS each cover one aspect of a specific equipment interface and are to be used in conjunction with Part 1 [1], which contains references and test circuits that are common to all parts of this ETS.

The corresponding ETS for ISDN primary rate access is ETS 300 046 ("Integrated Services Digital Network (ISDN); Primary rate access - safety and protection", Parts 1 to 5).

Blank page

1 Scope

See Clause 1 of ETS 300 047-1 [1].

This part of the ETS covers the safety requirements for interface I_b of NT2.

2 Normative references

This ETS incorporates by dated or undated reference, provisions from other publications. These normative references are cited at the appropriate places in the text and the publications are listed hereafter. For dated references, subsequent amendments to or revisions of any of these publications apply to this ETS only when incorporated in it by amendment or revision. For undated references the latest edition of the publication referred to applies.

EN 41003 [3] and EN 60950 [2] contain Special National Conditions and National A-deviations for some countries. Where these deviations apply to provisions that are referred to in this ETS, they shall apply to equipment complying with this ETS, intended for use in those countries.

- [1] ETS 300 047-1 (1992): "Integrated Services Digital Network (ISDN); Basic access - safety and protection - Part 1: General".
- [2] EN 60950 (1988 including amendments 1 and 2): "Safety of information technology equipment, including electrically operated business machines".
- [3] EN 41003 (1991): "Particular electrical safety requirements for equipment to be connected to telecommunication networks".
- [4] HD 384-5-54 (IEC 364-5-54): "Electrical installations of buildings - Earthing arrangements and protective conductors".
- [5] prHD 384-7-707 S1 (IEC 364-7-707): "Electrical installations of buildings - Earthing requirements for the installation of data processing equipment".

3 Definitions and abbreviations

3.1 Definitions

For the purpose of this part of the ETS, the definitions given in subclause 3.1 of ETS 300 047-1 [1] apply.

However, for the purposes of this part of the ETS, the Equipment Under Test (EUT) is a Network Termination (NT).

3.2 Abbreviations

For the purpose of this part of the ETS, the abbreviations given in subclause 3.2 of ETS 300 047-1 [1] apply.

4 Reference configuration

See Clause 4 of ETS 300 047-1 [1].

5 Safety requirements and tests

5.1 General

This Clause contains requirements for aspects of safety associated with connection to the ISDN basic access user-network interface to which an NT2 shall comply. The requirements are based on EN 60950 [2] and EN 41003 [3].

Interface I_b shall comply with the requirements for accessible parts of an Safety Extra Low Voltage (SELV) circuit, however only two methods of separation from excessive voltages are permitted.

These methods are:

- a) double or reinforced insulation according to subclause 2.3.4 of EN 60950 [2], and
- b) basic insulation plus protective earth screen according to subclause 2.3.5 of EN 60950 [2].

Subclause 4.4.2 of EN 41003 [3] does not apply to interface I_b .

The transmit and receive pairs of interface I_b are indicated in the figures by "t" and "r" respectively.

If there are any Telecommunication Network Voltage (TNV) circuits in the EUT they shall comply with EN 41003 [3] in all respects.

5.2 Test conditions

See Clause 5 of ETS 300 047-1 [1].

In the figures of this ETS, the required surge generators, coupling networks and terminating networks are shown in outline. The figure numbers in those outlines refer to the figures in the annexes to ETS 300 047-1 [1], as follows:

- Annex C (normative): Coupling networks;
- Annex E (normative): Measuring device for touch current.

5.3 Touch current

If the connection point for an interface cable shield is connected to protective earth, it shall not be connected to the measuring device during the tests, as shown in figures 1, 2 and 3.

5.3.1 Equipment without auxiliary interfaces

Test circuit: figure 1.

Test criterion: the weighted touch current measured across any single interface I_b shall not exceed 0,25 mA.

The switch S shall be operated to find the higher result.

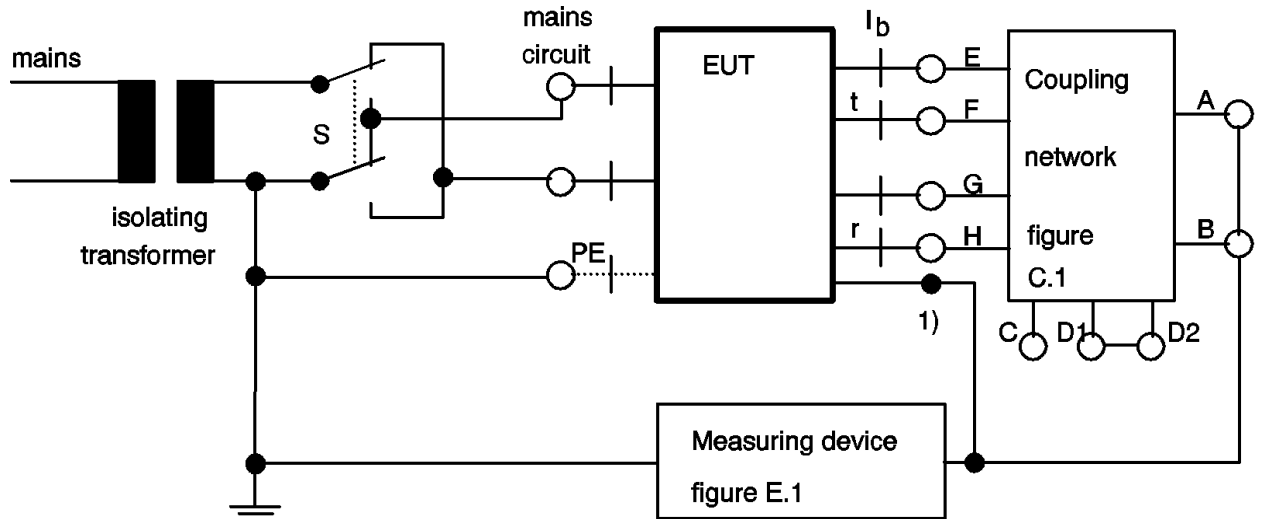

NOTE: The coupling network, ETS 300 047-1 [1], figure C.1, is used for functional matching purposes and to avoid a short circuit for d.c. current during this test.

1) = Connection point for interface cable shield, if any.

Figure 1: Touch current test circuit for mains powered equipment without auxiliary interfaces.

5.3.2 Equipment with auxiliary interfaces

For the purpose of this subclause, any interfaces I_b , other than the one under test, shall be treated as auxiliary interfaces.

NOTE: An NT2 is often a complex installation with numerous and varied interfaces. Each interface can carry a touch current of up to 0,25 mA. With multiple interfaces, touch currents can sum up at a common point, such as a common power source or a common connection point for several interface cable shields. The following methods have been identified for avoiding an excessive touch current at any one interface:

- separating all interfaces from each other so that no summing of touch current can occur;
- bonding of common power or shield connection points to earth.

The requirements that follow depend on which method is chosen by the manufacturer.

The manufacturer shall declare for test purposes which of the following methods is used to limit touch current:

- separation of interface I_b from all auxiliary interfaces;
- bonding of common power or shield connection points to an earth potential reference.

All pins, other than earthed pins, of each individual auxiliary interface shall be connected together in a manner appropriate to that interface, and then connected to the current limiting capacitor. Where it would be inappropriate to connect pins directly to each other, they shall be connected to individual capacitors which are in turn connected together; the total capacitance of such capacitors in parallel shall be the required 3,3 nF.

Test circuit: figure 2 or 3 as appropriate.

Test circuit switch S1: operated to find the higher result.

Test circuit switch S2: see test criterion.

Test criterion: the weighted touch current I_t measured across any single interface I_b shall be as follows:

- if "separation" is declared,

≤ 0,25 mA with S2 closed;

≤ 0,25 mA with S2 open;

- if "bonding" is declared,

≤ 0,25 mA with S2 closed;

any value with S2 open, but see table 1.

If the equipment is to be permanently earthed in accordance with Annex A, bullet point A.5 of this part of the ETS, the test with S2 open is not carried out.

If "bonding" is declared, the manufacturer shall specify in the installation instructions the necessary minimum quality of connection to protective earth, depending on the measured value of I_t (see also annex A) and according to table 1.

Table 1: Quality of connection to protective earth

I_t mA	Minimum quality of connection to protective earth (see Annex A)
≤ 0,25	No minimum. See bullet point A.2
> 0,25 ≤ 3,5	In accordance with bullet point A.3
> 0,25 ≤ 10	In accordance with bullet point A.4
> 10	In accordance with bullet point A.5

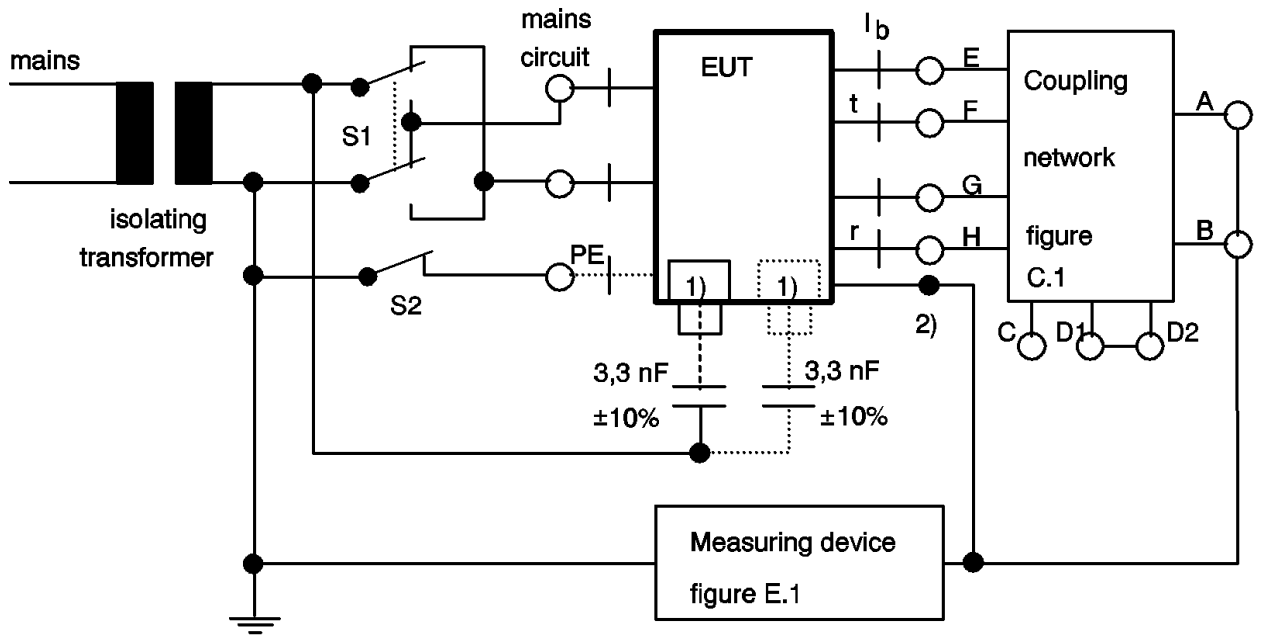

- 1) Auxiliary interfaces.
- 2) Connection point for interface cable shield, if any.

Figure 2: Touch current test circuit for mains powered equipment having auxiliary interfaces

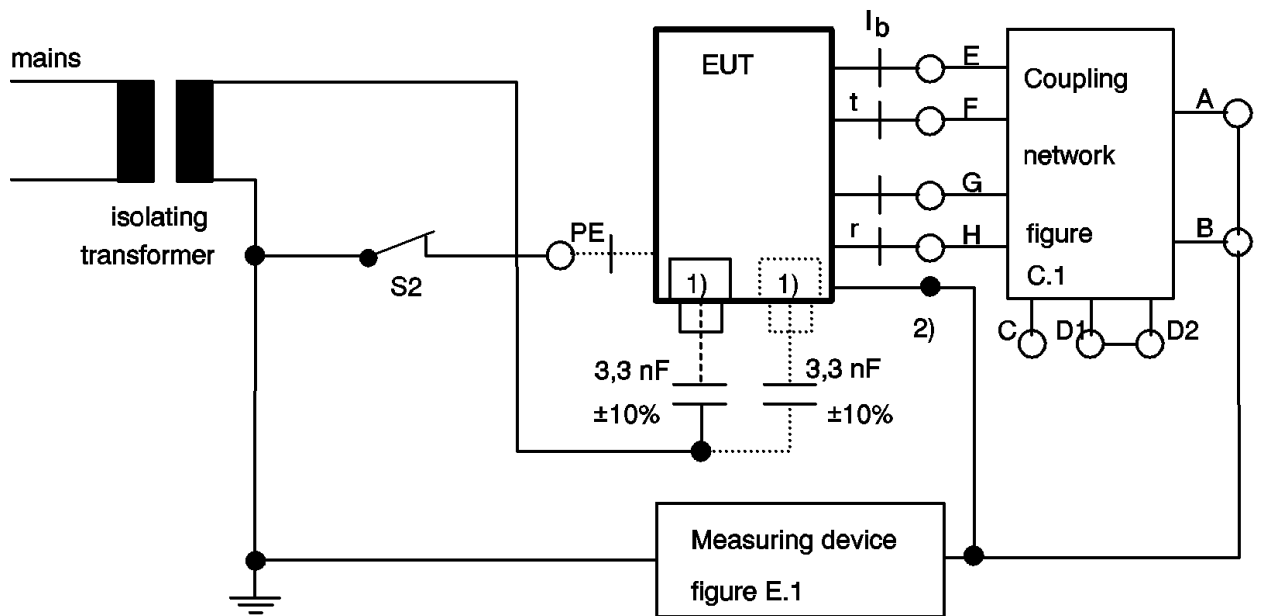

- 1) Auxiliary interfaces.
- 2) Connection point for interface cable shield, if any.

Figure 3: Touch current test circuit for equipment having auxiliary interfaces, not mains powered

Annex A (normative):

Connection of PE conductor for equipment with multiple interfaces

- A.1** If "bonding" is declared by the manufacturer (see subclause 5.3.2) a minimum quality of connection to protective earth (PE) may be necessary.

Four levels of quality, one of which has to be specified in the manufacturer's installation instructions, are given in points A.2 to A.5 below. Which of the four levels is the minimum level for a particular equipment depends on the value of weighted touch current I_t measured during the tests in subclause 5.3.2 (see table 1). A higher quality of connection than that specified is acceptable.

- A.2** No installation requirements need to be specified for compliance with this ETS. However, protective earthing requirements may apply for other purposes.

- A.3** Connection via the PE conductor of the power supply cord according to EN 60950 [2];

or

fixed connection via a separate PE conductor according to HD 384-5-54 (IEC 364-5-54) [4].

- A.4** Connection via the PE conductor of the power supply cord of pluggable equipment type B or permanently connected equipment as defined in EN 60950 [2];

or

fixed connection via a separate PE conductor according to HD 384-5-54 (IEC 364-5-54) [4].

- A.5** Permanent connection according to EN 60950 [2], HD 384-5-54 (IEC 364-5-54) [4] and prHD 384-7-707 S1 (IEC 364-7-707) [5];

or

fixed connection via a separate PE conductor according to HD 384-5-54 (IEC 364-5-54) [4] and prHD 384-7-707 S1 (IEC 364-7-707) [5].

History

Document history	
August 1992	First Edition
November 1995	Converted into Adobe Acrobat Portable Document Format (PDF)