



EUROPEAN
TELECOMMUNICATION
STANDARD

ETS 300 046-5

August 1992

Source: ETSI TC-TE

Reference: T/TE 04-31

ICS: 33.080

Key words: ISDN, primary rate access, safety, protection

**Integrated Services Digital Network (ISDN);
Primary rate access - safety and protection
Part 5: Interface I_b - protection**

ETSI

European Telecommunications Standards Institute

ETSI Secretariat

Postal address: F-06921 Sophia Antipolis CEDEX - FRANCE

Office address: 650 Route des Lucioles - Sophia Antipolis - Valbonne - FRANCE

X.400: c=fr, a=atlas, p=etsi, s=secretariat - **Internet:** secretariat@etsi.fr

Tel.: +33 92 94 42 00 - Fax: +33 93 65 47 16

Copyright Notification: No part may be reproduced except as authorized by written permission. The copyright and the foregoing restriction extend to reproduction in all media.

© European Telecommunications Standards Institute 1992. All rights reserved.

Contents

Foreword	5
1 Scope	7
2 Normative references	7
3 Definitions and abbreviations	7
3.1 Definitions	7
3.2 Abbreviations	7
4 Reference configurations	8
5 Protection requirements and tests	8
5.1 General	8
5.2 Test conditions.....	8
5.3 Compliance criteria	8
5.4 Test generators and networks	8
5.5 Overvoltage surge simulation at interface I_p	9
5.5.1 Common mode test.....	9
5.5.2 Transverse mode test between transmit and receive pairs.....	10
5.6 Mains overvoltage simulation.....	10
5.6.1 Common mode test.....	11
5.6.2 Transverse mode test	12
5.7 Impulse transfer	12
5.7.1 Impulse transfer from mains (common mode and transverse mode)	13
5.7.2 Impulse transfer from auxiliary interface	14
5.7.3 Conversion of common mode to transverse mode	15
5.8 Electrostatic discharge (ESD).....	15
5.9 Miswiring resistibility test.....	16
Annex A (normative): Enhanced requirements for "extra-strength equipment"	17
History.....	18

Blank page

Foreword

This European Telecommunication Standard (ETS) has been produced by the Terminal Equipment (TE) Technical Committee of the European Telecommunications Standards Institute (ETSI) in collaboration with members of the Business Telecommunications (BT) and Transmission and Multiplexing (TM) Technical Committees.

This ETS aims to meet the urgent requirements of network operators and equipment manufacturers who are designing equipment to operate with the Integrated Services Digital Network (ISDN) primary rate access interface.

This is the fifth part of a multi-part ETS which comprises the following:

ETS 300 046: "Integrated Services Digital Network (ISDN); Primary rate access - safety and protection".

ETS 300 046-1 (Part 1): General.

ETS 300 046-2 (Part 2): Interface I_a - safety.

ETS 300 046-3 (Part 3): Interface I_a - protection.

ETS 300 046-4 (Part 4): Interface I_b - safety.

ETS 300 046-5 (Part 5): Interface I_b - protection

Parts 2 to 5 of this ETS each cover one aspect of a specific equipment interface and are to be used in conjunction with Part 1 [3], which contains references and test circuits that are common to all parts of this ETS.

The corresponding ETS for ISDN basic access is ETS 300 047 ("Integrated Services Digital Network (ISDN); Basic access - safety and protection, Parts 1 to 5").

Blank page

1 Scope

See Clause 1 of ETS 300 046-1 [3].

This part of the ETS covers the protection requirements for interface I_b.

2 Normative references

This ETS incorporates, by dated or undated reference, provisions from other publications. These normative references are cited at the appropriate places in the text and the publications are listed hereafter. For dated references, subsequent amendments to or revisions of any of these publications apply to this ETS only when incorporated in it by amendment or revision. For undated references, the latest edition of the publication referred to applies.

EN 41003 [1] and EN 60950 [2] contain Special National Conditions and National A-deviations for some countries. Where these deviations apply to provisions that are referred to in this ETS, they shall apply to equipment complying with this ETS, intended for use in those countries.

- [1] EN 41003 (1991): "Particular electrical safety requirements for equipment to be connected to telecommunication networks".
- [2] EN 60950 (1988, including amendments 1 and 2): "Safety of information technology equipment including electrically operated business machines".
- [3] ETS 300 046-1: "Integrated Services Digital Network (ISDN); Primary rate access - safety and protection - Part 1: General".
- [4] ETS 300 046-4: "Integrated Services Digital Network (ISDN); Primary rate access - safety and protection - Part 4: Interface I_b - safety".
- [5] ETS 300 046-2: "Integrated Services Digital Network (ISDN); Primary rate access - safety and protection - Part 2: Interface I_a - safety".
- [6] IEC 801-2 (1991): "Electromagnetic compatibility for industrial-process measurement and control equipment - Part 2: Electrostatic discharge requirements".
- [7] ETS 300 011 (1992): "Integrated Services Digital Network (ISDN); Primary rate user-network interface, Layer 1 specification and test principles".

3 Definitions and abbreviations

3.1 Definitions

For the purpose of this part of the ETS, the definitions provided in subclause 3.1 of ETS 300 046-1 [3] apply.

However, for the purpose of this part of the ETS the Equipment Under Test (EUT) is a Network Termination (NT).

3.2 Abbreviations

For the purpose of this part of the ETS, the abbreviations given in subclause 3.2 of ETS 300 046-1 [3] apply.

4 Reference configurations

See Clause 4 of ETS 300 046-1 [1].

5 Protection requirements and tests

5.1 General

Clause 5 assigns test voltages and currents and specifies test circuits and conditions.

The transmit and receive pairs of interface I_b are indicated in the figures by "t" and "r".

5.2 Test conditions

See Clause 5 of ETS 300 046-1 [3].

For the purpose of this part of the ETS, if any, an interface I_a , including its power feeding pair, shall be treated as an auxiliary interface (see subclause 5.6 of ETS 300 046-1 [1]).

5.3 Compliance criteria

See subclause 3.1 of ETS 300 046-1 [3].

5.4 Test generators and networks

In the figures of this part of the ETS, the required test generators coupling networks and terminating networks are shown in outline. The figure numbers in those outlines refer to the figures in annexes to ETS 300 046-1 [3], as follows:

- Annex B (normative): Test generators;
- Annex C (normative): Coupling networks;
- Annex D (normative): Terminating network.

5.5 Overvoltage surge simulation at interface I_b

5.5.1 Common mode test

The test shall be carried out with connection point 2) connected to the reference plane as shown in figure 1. Except where "bonding" is declared by the manufacturer (see subclause 5.3 of ETS 300 046-4 [4]) the test shall be repeated with connection point 2) disconnected from the reference plane.

Test circuit: figure 1.
Maximum test voltage U_c: 1 kV.
Pulse form: 1,2/50 μs.
Number of pulses: 10.
Compliance criterion: A.

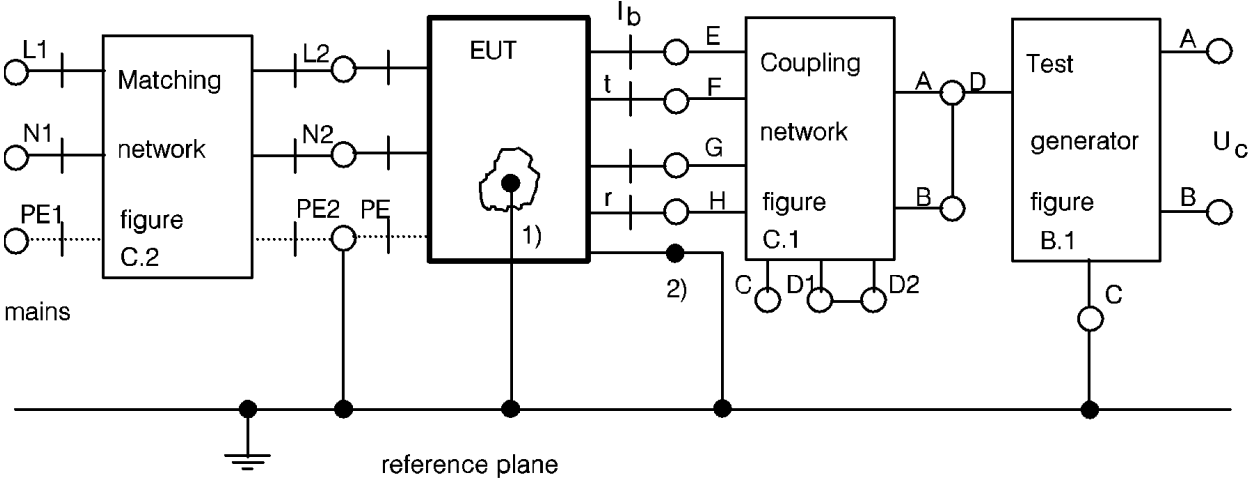

- 1) User-accessible part or metal foil.
- 2) Connection point for interface cable shield.

Figure 1: Test circuit for overvoltage surge simulation; common mode

5.5.2 Transverse mode test between transmit and receive pairs

The test shall be carried out with connection point 2) connected to the reference plane as shown in figure 2. Except where "bonding" is declared by the manufacturer (see subclause 5.3 of ETS 300 046-4 [4]) the test shall be repeated with connection point 2) disconnected from the reference plane.

Test circuit: figure 2.
 Maximum test voltage U_c : 250 V.
 Pulse form: 1,2/50 μ s.
 Number of pulses: 10.
 Compliance criterion: A.

The test shall be repeated with "t" and "r" interchanged.

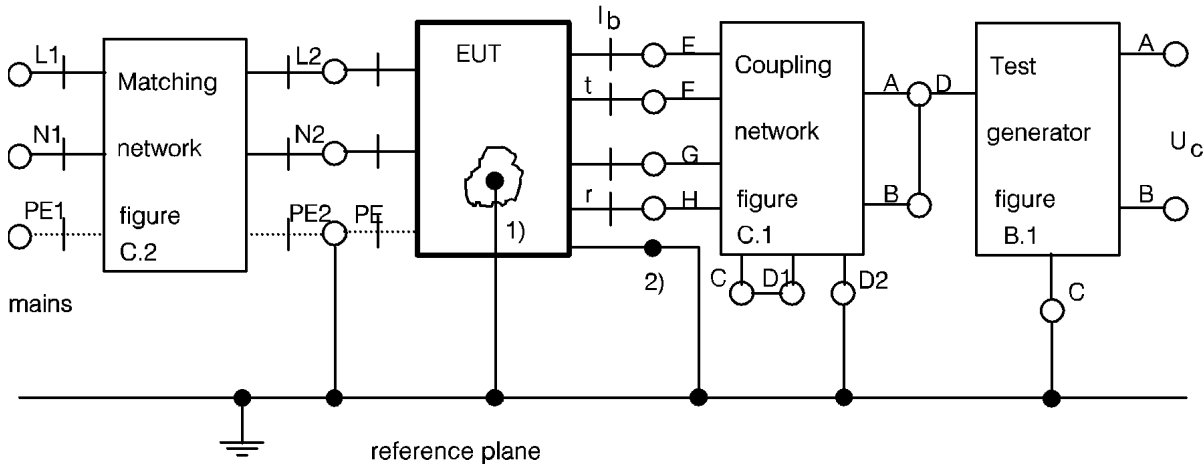

- 1) User-accessible part or metal foil.
- 2) Connection point for interface cable shield.

Figure 2: Test circuit for overvoltage surge simulation; transverse mode

5.6 Mains overvoltage simulation

NOTE: The test conditions and parameters in subclause 5.6 are based on CCITT Recommendation K.22, IEC 364 and IEC 664 (see Clause 2 of ETS 300 046-1 [3]).

5.6.1 Common mode test

The test shall be carried out with connection point 2) connected to the reference plane as shown in figure 3. Except where "bonding" is declared by the manufacturer (see subclause 5.3 of ETS 300 046-4 [4]) the test shall be repeated with connection point 2) disconnected from the reference plane.

Test circuit: figure 3.
 Maximum test voltage U_c : 2,5 kV.
 Pulse form: 10/700 μ s.
 Number of pulses: 10.
 Compliance criterion: A.

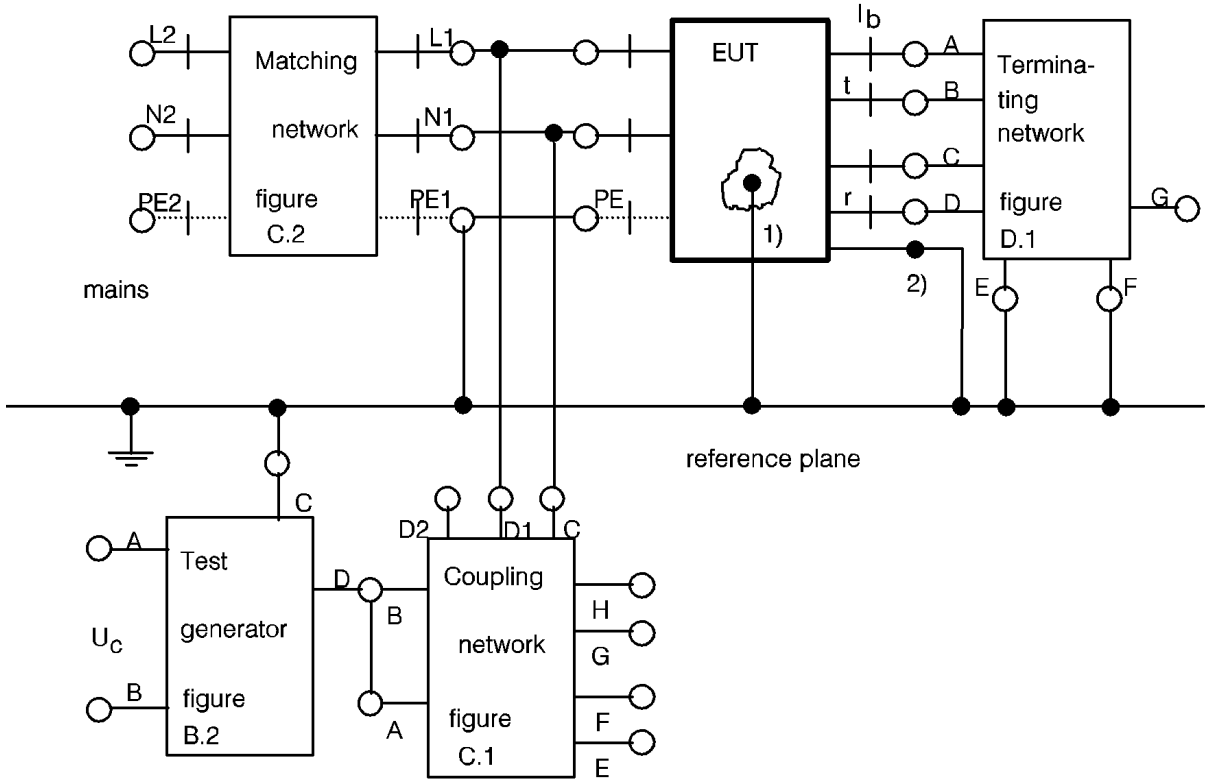

- 1) User-accessible part or metal foil.
- 2) Connection point for interface cable shield.

Figure 3: Test circuit for mains overvoltage simulation; common mode

5.6.2 Transverse mode test

The test shall be carried out with connection point 2) connected to the reference plane as shown in figure 4. Except where "bonding" is declared by the manufacturer (see subclause 5.3 of ETS 300 046-4 [4]) the test shall be repeated with connection point 2) disconnected from the reference plane.

Test circuit: figure 4.
 Maximum test voltage U_c : 2,5 kV.
 Pulse form: 10/700 μ s.
 Number of pulses: 10.
 Compliance criterion: A.

The test shall be repeated with "x" and "y" interchanged.

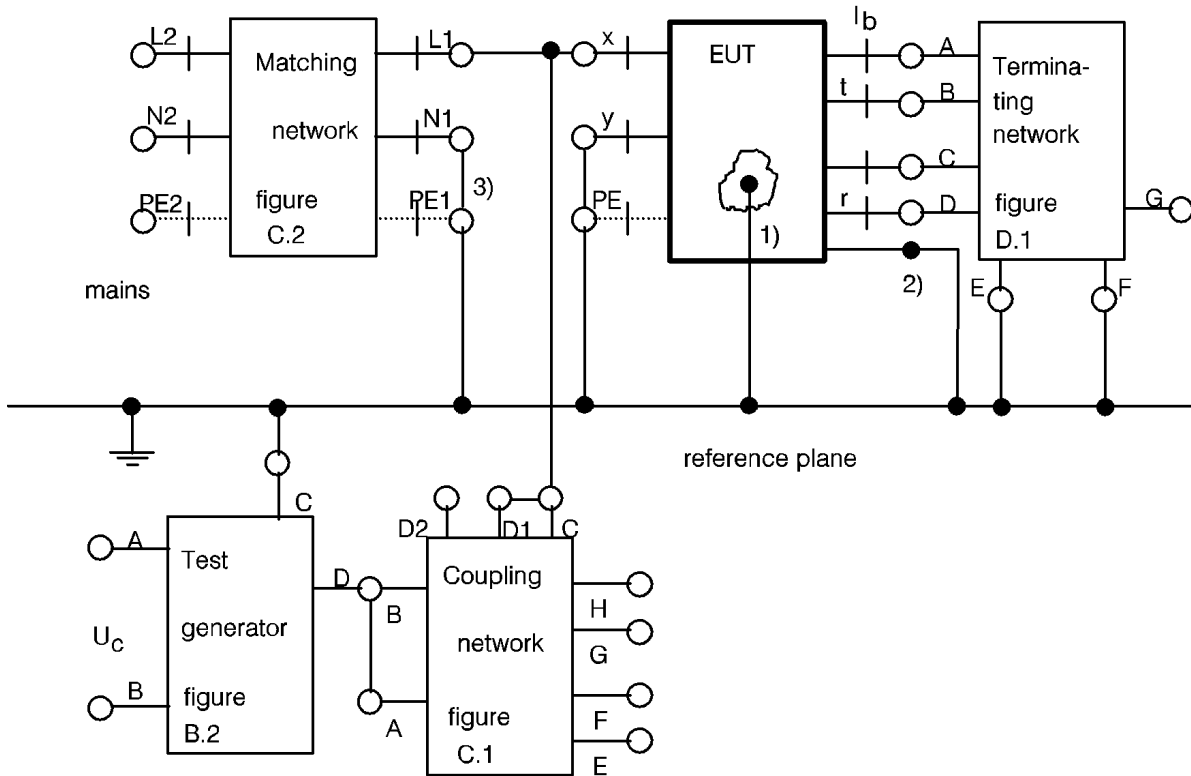

- 1) User-accessible part or metal foil.
- 2) Connection point for interface cable shield.
- 3) See subclause 5.3 of ETS 300 046-1 [3].

Figure 4: Test circuit for mains overvoltage simulation; transverse mode

5.7 Impulse transfer

Two mechanisms for overvoltage transfer are measured by the tests in subclause 5.7:

- transfer of overvoltage from one interface (e.g. mains or interface I_a or an auxiliary interface) to interface I_b ;
- conversion of common mode voltage at interface I_b to transverse mode at the same interface.

5.7.1 Impulse transfer from mains (common mode and transverse mode)

Except where "bonding" is declared by the manufacturer (see subclause 5.3 of ETS 300 046-4 [4]) the test shall be carried out with no connection-to-connection point 1).

The test shall be carried out with connection point 2) connected to the reference plane as shown in figure 5 and 6. Except where "bonding" is declared by the manufacturer (see subclause 5.3 of ETS 300 046-4 [4]) the test shall be repeated with connection point 2) disconnected from the reference plane.

For the tests in transverse mode, the tests shall be repeated with "x" and "y" interchanged.

Test circuit: figures 5 and 6.
 Test voltage U_c : 2,5 kV.
 Pulse form: 10/700 μ s.
 Number of pulses: 2; one for each polarity.
 Compliance criteria: at the terminating network, figure D.1, the voltage between:
 - E and G shall not exceed 1 kV peak,
 - F and G shall not exceed 1 kV peak,
 - E and F shall not exceed 250 V peak.

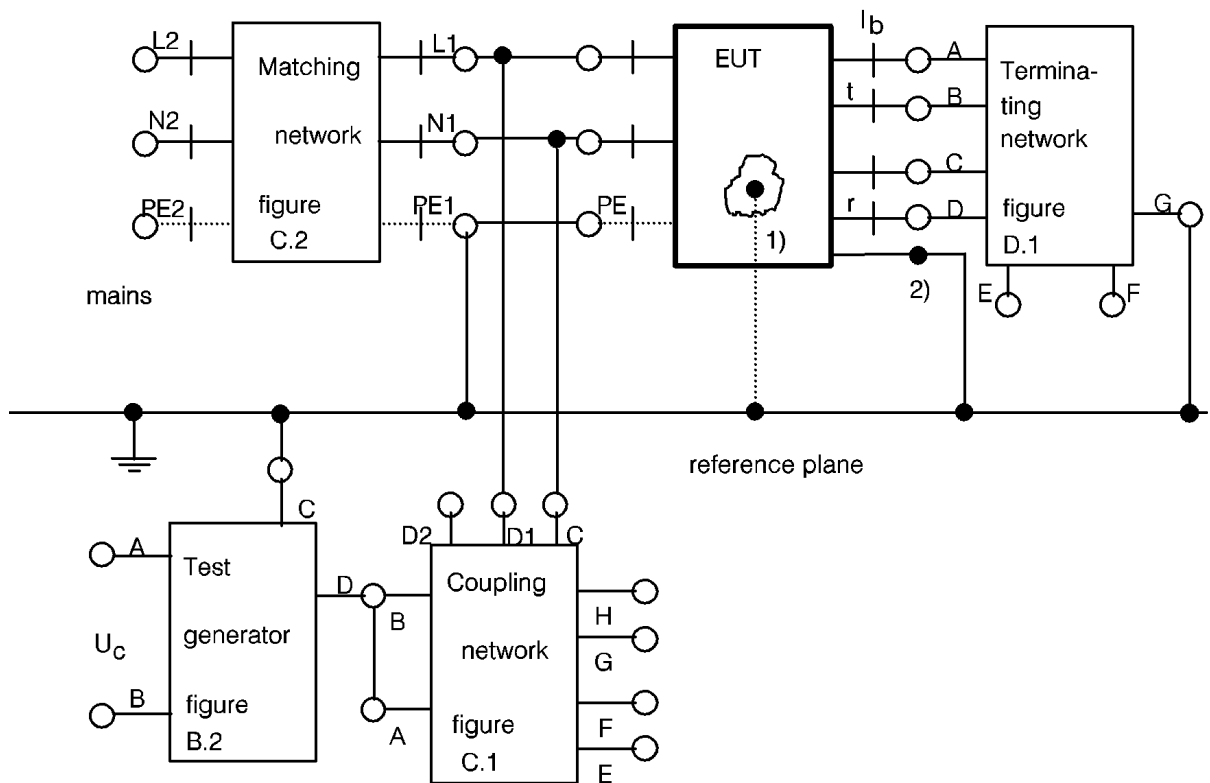

- 1) User-accessible part or metal foil.
- 2) Connection point for interface cable shield.

Figure 5: Test circuit for impulse transfer from mains; common mode

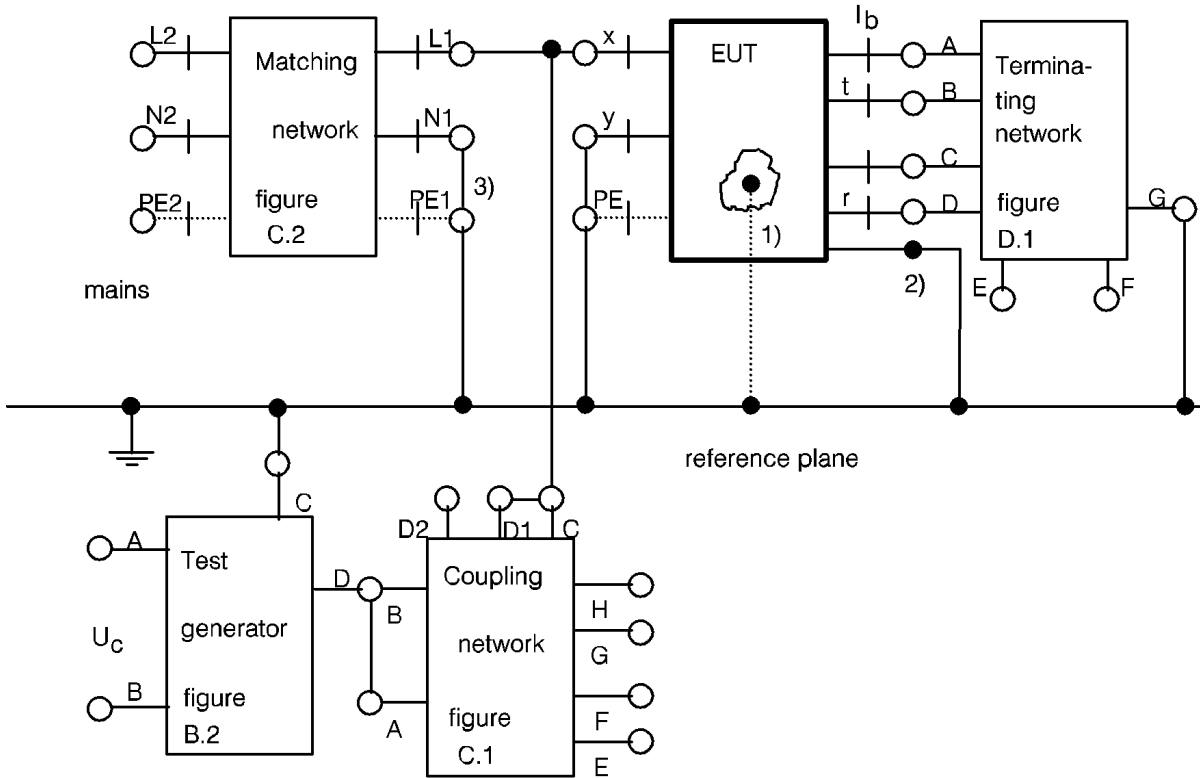

- 1) User-accessible part or metal foil.
- 2) Connection point for interface cable shield.
- 3) See subclause 5.3 of ETS 300 046-1 [3].

Figure 6: Test circuit for impulse transfer from mains; transverse mode

5.7.2 Impulse transfer from auxiliary interface

If "bonding" is declared by the manufacturer (see subclause 5.3 of ETS 300 046-4 [4]) this test is unnecessary and shall not be carried out.

For the purpose of this test, any interfaces I_b other than the one under test shall be treated as auxiliary interfaces.

The test shall be applied to each type of construction of auxiliary interface, but only where the interface has a specified maximum withstand test voltage greater than 250 V in common or transverse mode.

The test shall be carried out with no connection of connection point 1) to the reference plane.

The test shall be carried out with connection point 2) connected to the reference plane as shown and repeated with connection point 2) disconnected from the reference plane.

Test circuit:	figure 7.
Test voltage U_c :	as specified in relevant standard.
Pulse form:	as specified in relevant standard.
Number of applications:	two; one for each polarity.
Compliance criteria:	at the terminating network, figure D.1, the voltage between:
	- E and G shall not exceed 1 kV peak,
	- F and G shall not exceed 1 kV peak,
	- E and F shall not exceed 250 V peak.

In the absence of a relevant standard of equipment to be connected to the auxiliary interface, U_c and the pulse form shall be determined and declared by the manufacturer of the EUT. Guidance can be found in ETR 012 ("Terminal Equipment (TE); Safety categories and protection levels at various interfaces for telecommunication equipment in customer premises").

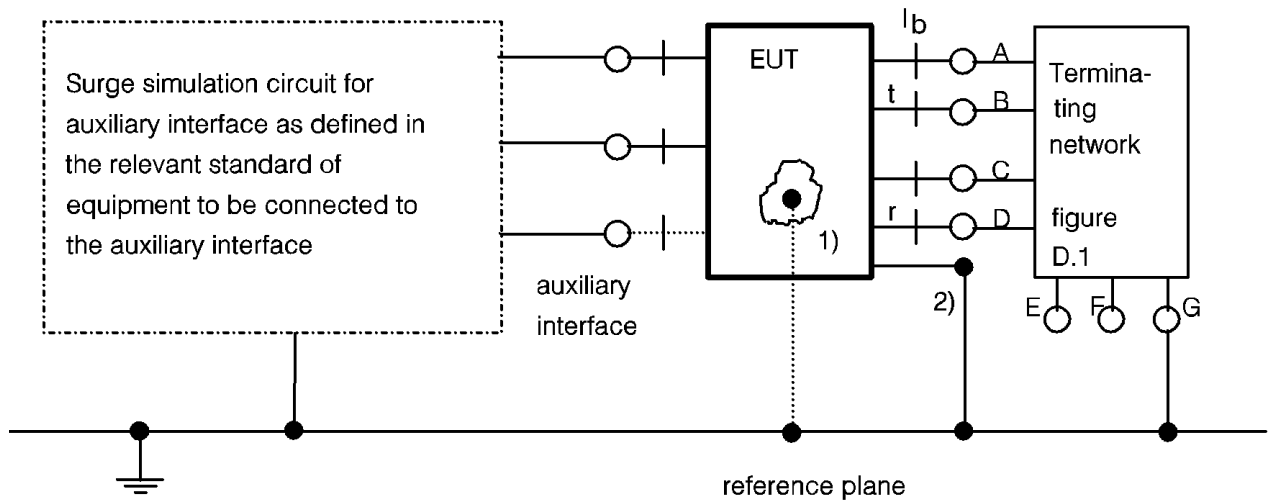

- 1) User-accessible part or metal foil.
- 2) Connection point for interface cable shield.

Figure 7: Test circuit for impulse transfer from auxiliary interfaces

5.7.3 Conversion of common mode to transverse mode

The test shall be carried out with connection point 2) connected to the reference plane as shown in figure 1. Except where "bonding" is declared by the manufacturer (see subclause 5.3 of ETS 300 046-2 [5]) the test shall be repeated with connection point 2) disconnected from the reference plane.

Test circuit:	figure 1.
Test voltage:	1 kV peak.
Pulse form:	1,2/50 μ s.
Number of pulses:	two; one for each polarity.
Compliance criterion:	at the Coupling network, figure C.1, the voltage between C and D1 + D2 shall not exceed 250 V peak.

5.8 Electrostatic discharge (ESD)

For this test IEC 801-2 [6] shall be applied. Severity level 2 shall be used for contact discharge (4 kV charging voltage) and severity level 4 are used for air discharge (15 kV charging voltage).

Except where "bonding" is declared by the manufacturer (see subclause 5.3 of ETS 300 046-4 [4]), the test shall be carried out with no connection to connection point 1).

The test shall be carried out with connection point 2) connected to the reference plane as shown. Except where "bonding" is declared by the manufacturer (see subclause 5.3 of ETS 300 046-2 [5]) the test shall be repeated with connection point 2) disconnected from the reference plane.

Test circuit: figure 8.
Compliance criterion: A.

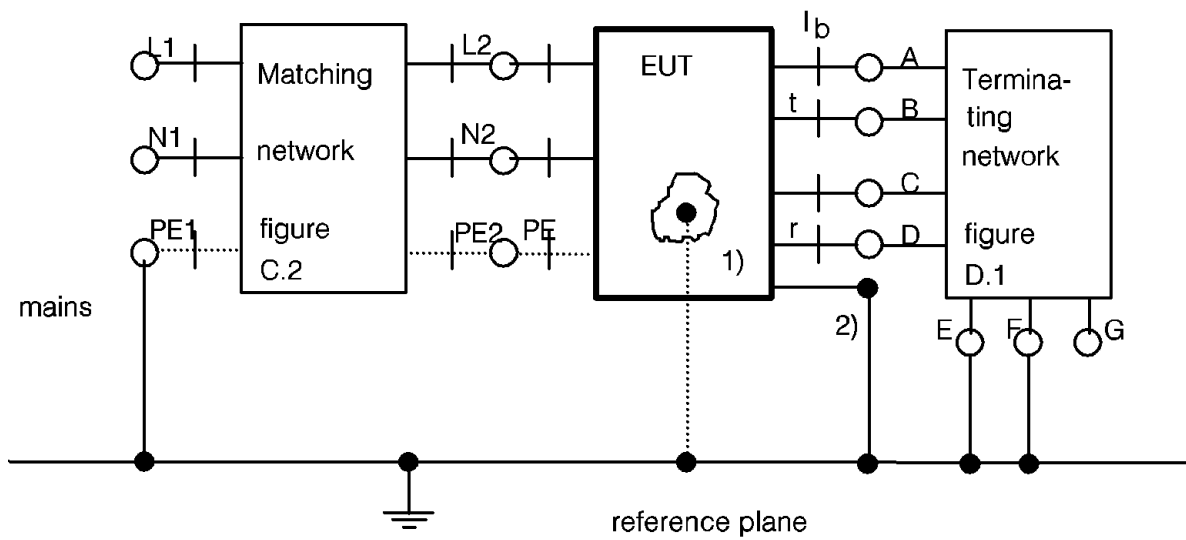

- 1) User-accessible part or metal foil.
- 2) Connection point for interface cable shield.

Figure 8: ESD test circuit

5.9 Miswiring resistibility test

Short circuit and overload protection for power sources are specified in ETS 300 011 [7].

Annex A (normative): Enhanced requirements for "extra-strength equipment"

A.1 The following additional test shall be carried out

Test circuit: figure A.1.
Test voltage: 6 kV r.m.s., 50Hz.
Duration: 1 s.
Compliance criterion: A.

A.2 For tests according to subclause 5.6.1 the following parameters apply:

Test circuit: figure 3.
Maximum test voltage U_c : 10 kV.
Pulse form: 10/700 μ s.
Number of pulses: 10, with alternating polarity.

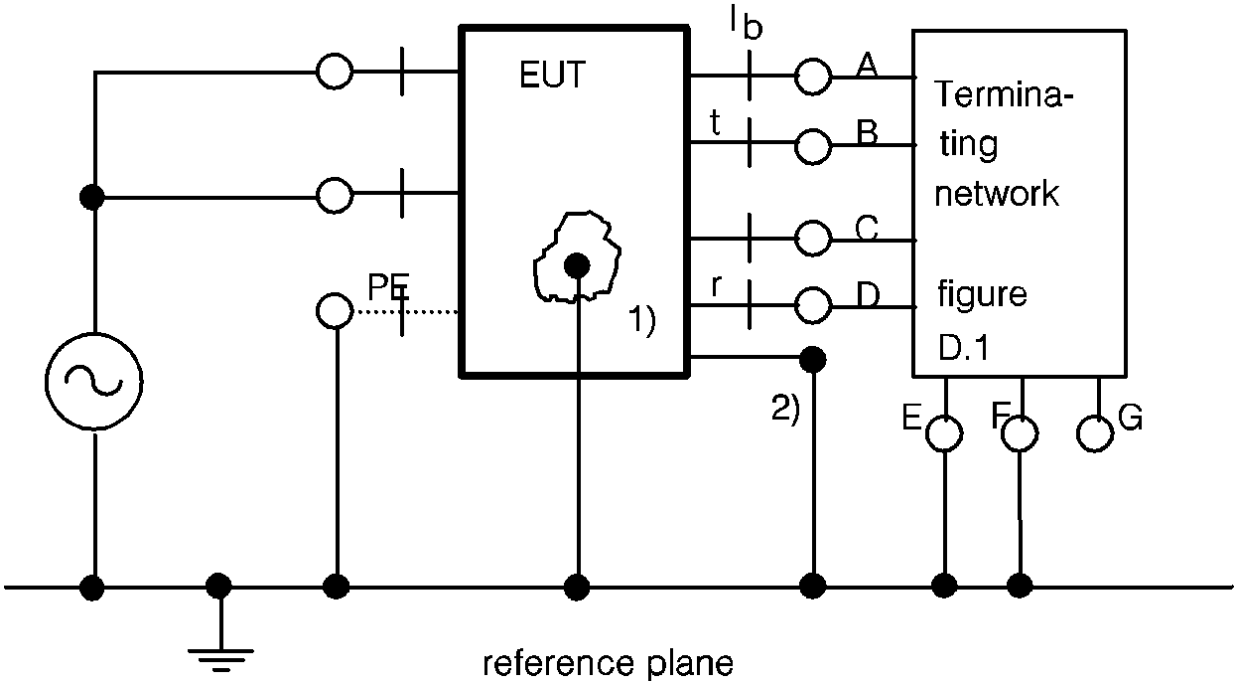

- 1) User-accessible part or metal foil.
- 2) Connection point for interface cable shield.

Figure A.1: 50 Hz test circuit for extra-strength equipment

History

Document history	
August 1992	First Edition
November 1995	Converted into Adobe Acrobat Portable Document Format (PDF)