

**E**UROPEAN  
**T**ELECOMMUNICATION  
**S**TANDARD

**DRAFT**  
pr **ETS 300 012-5**

November 1996

Second Edition

---

Source: ETSI TC-TM

Reference: RE/TM-03038-5

ICS: 33.040.20

**Key words:** Basic, ISDN, layer 1, testing, transmission, UNI

**Integrated Services Digital Network (ISDN);  
Basic User Network Interface (UNI);  
Part 5: Conformance test specification for interface I<sub>B</sub>**

**ETSI**

European Telecommunications Standards Institute

**ETSI Secretariat**

**Postal address:** F-06921 Sophia Antipolis CEDEX - FRANCE

**Office address:** 650 Route des Lucioles - Sophia Antipolis - Valbonne - FRANCE

**X.400:** c=fr, a=atlas, p=etsi, s=secretariat - **Internet:** secretariat@etsi.fr

Tel.: +33 4 92 94 42 00 - Fax: +33 4 93 65 47 16

---

**Copyright Notification:** No part may be reproduced except as authorized by written permission. The copyright and the foregoing restriction extend to reproduction in all media.

© European Telecommunications Standards Institute 1996. All rights reserved.



## Contents

Foreword .....	5
1 Scope .....	7
2 Normative references .....	7
3 Definitions, symbols and abbreviations .....	8
3.1 Definitions .....	8
3.2 Symbols .....	9
3.3 Abbreviations .....	9
4 Allocation of tests .....	11
4.1 Scope .....	11
4.2 Normative references .....	11
4.3 Definitions, symbols and abbreviations .....	11
4.4 Primitives associated with layer 1 .....	12
4.5 Wiring configurations and location of interface points .....	12
4.6 Functional characteristics .....	12
4.7 Interface procedures .....	13
4.8 Electrical characteristics .....	14
4.9 Power feeding .....	15
4.10 Interface connector contact assignment .....	16
4.11 Annexes .....	17
5 Functional characteristic tests .....	18
5.1 Binary organization of frame .....	18
5.1.1 Test A .....	18
5.1.2 Test B .....	20
6 Interface procedure tests .....	21
6.1 D-channel interframe (layer 2) time fill .....	21
6.2 D-echo channel response .....	22
6.3 Activation/deactivation .....	23
6.3.1 Activation/deactivation procedure .....	23
6.3.2 Activation/deactivation time .....	25
6.3.2.1 NT activation time .....	25
6.3.2.1.1 Test A in state G1 .....	25
6.3.2.1.2 Test B in state G2 .....	26
6.3.2.2 Deactivation time .....	27
6.3.2.3 Value of the timer T2 .....	28
6.4 Frame alignment procedures .....	29
7 Electrical characteristics tests .....	30
7.1 Bit rate .....	30
7.1.1 Bit rate when transmitting an INFO 2 .....	30
7.1.2 Bit rate when transmitting an INFO 4 .....	31
7.2 NT jitter characteristics .....	32
7.3 NT transmitter output impedance .....	33
7.3.1 Test A .....	33
7.3.2 Test B .....	34
7.4 Pulse shape and amplitude .....	35
7.5 Pulse unbalance .....	36
7.5.1 Pulse amplitude .....	36
7.5.2 Pulse unbalance of an isolated couple of pulses .....	37
7.6 Longitudinal conversion loss of transmitter output .....	38
7.7 Receiver input characteristics .....	39
7.7.1 NT receiver input impedance .....	39

	7.7.1.1	Test A.....	39
	7.7.1.2	Test B.....	40
	7.7.2	Receiver sensitivity - noise and distortion immunity .....	41
	7.7.3	NT receiver input delay characteristics.....	42
	7.7.4	Unbalance about earth of the receiver input.....	43
8	Power feeding.....		44
	8.1	Power source 1 .....	44
	8.1.1	Normal power condition .....	44
	8.1.2	Restricted power provision .....	45
	8.1.3	Power source switch-over time.....	46
	8.1.4	Power source 1 restricted mode under overload conditions.....	47
	8.1.4.1	Test A (E.5.1.4.1).....	47
	8.1.4.2	Test B.....	48
	8.1.4.3	Test C .....	49
	8.1.4.4	Test D .....	50
	8.1.5	Requirements for type "a" sources .....	51
	8.1.6	Switch on surge capability .....	52
	8.1.7	TE connection surge capability .....	53
	8.1.8	dc unbalance of power source 1 .....	54
	8.1.9	Current unbalance in a pair .....	55
	8.2	Minimum voltage of power source 2 .....	56
9	Auxiliary power supply .....		57
	9.1	Additional requirements from an APS .....	57
	9.1.1	APS switch-on time.....	58
	9.1.2	APS switch-off time.....	59
	9.1.3	APS requirements for type "a" sources .....	60
	9.1.4	APS switch-on surge capability.....	61
	9.1.5	APS TE connection surge capability.....	62
	9.1.6	APS current unbalance in a pair .....	63
	9.2	Additional requirements for NT compatible with APS .....	64
	9.2.1	Power source 1 mode back-off.....	64
	9.2.2	Power source 1 restricted mode power-up.....	65
	9.2.3	Power consumption from APS normal mode .....	66
Annex A (normative):	Connection cords and general testing requirements .....		67
A.1	Connection cords.....		67
A.2	General testing requirements .....		67
History .....			69

## Foreword

This draft second edition European Telecommunication Standard (ETS) has been produced by the Transmission and Multiplexing (TM) Technical Committee of the European Telecommunications Standards Institute (ETSI), and is now submitted for the Public Enquiry phase of the ETSI standards approval procedure.

This ETS concerns the basic User Network Interface (UNI) for the Integrated Services Digital Network (ISDN) and consists of 7 parts as follows:

- Part 1: "Layer 1 specification";
- Part 2: "Implementation Conformance Statement (ICS) and Implementation Extra Information for Testing (IXIT) for interface I<sub>A</sub>";
- Part 3: "Implementation Conformance Statement (ICS) and Implementation Extra Information for Testing (IXIT) for interface I<sub>B</sub>";
- Part 4: "Conformance test specification for interface I<sub>A</sub>";
- Part 5: "Conformance test specification for interface I<sub>B</sub>";**
- Part 6: "Abstract Test Suite (ATS) specification for interface I<sub>A</sub>";
- Part 7: "Abstract Test Suite (ATS) specification for interface I<sub>B</sub>".

and is based on ITU-T Recommendation I.430 [1].

Proposed transposition dates	
Date of latest announcement of this ETS (doa):	3 months after ETSI publication
Date of latest publication of new National Standard or endorsement of this ETS (dop/e):	6 months after doa
Date of withdrawal of any conflicting National Standard (dow):	6 months after doa

Blank page

## 1 Scope

This part 5 of ETS 300 012 provides the test principles for the requirements of this ETS used to determine the compliance of an Implementation Under Test (IUT) to this ETS.

It is outside the scope of this ETS to identify the specific tests required by an implementation where equipment has to meet attachment approval.

Detailed test equipment accuracy and the specification tolerance of the test devices is not a subject of this ETS. Where such details are provided then those test details are to be considered as being an "informative" addition to the test description.

Unless otherwise stated, conformance tests described in this ETS do not apply to the Auxiliary Power Supply (APS).

Ideal values for components and circuits are considered in the test principles.

## 2 Normative references

This ETS incorporates by dated and undated reference, provisions from other publications. These normative references are cited at the appropriate places in the text and the publications are listed hereafter. For dated references, subsequent amendments to or revisions of any of these publications apply to this ETS only when incorporated in it by amendment or revision. For undated references the latest edition of the publication referred to applies.

- [1] ITU-T Recommendation I.430 (1995): "Basic user-network interface - layer 1 specification".
- [2] ITU-T Recommendation I.411 (1993): "ISDN user-network interfaces - reference configurations".
- [3] ETS 300 047-3 (1992): "Integrated Services Digital Network (ISDN); Basic access - safety and protection; Part 3: Interface I<sub>A</sub> - protection".
- [4] EN 60603-7 (1993): "Connectors for frequencies below 3 MHz for use with printed boards - Part 7: Detail specification for connectors, 8-way, including fixed and free connectors with common mating features; (IEC 603-7:1990)".
- [5] EN 28877 (1993): "Information technology; Telecommunications and information exchange between systems; Interface connector and contact assignments for ISDN Basic Access Interface located at reference point S and T; (ISO/IEC 8877: 1992)".
- [6] CCITT Recommendation G.117 (1988): "Transmission aspects of unbalance about earth (definitions and methods)".
- [7] ETS 300 102-1 (1990): Integrated Services Digital Network (ISDN); User-network interface layer 3; Specifications for basic call control".
- [8] ETS 300 012-1 (1996): "Integrated Services Digital Network (ISDN); Basic User Network Interface (UNI); Part 1: Layer 1 specification".
- [9] ITU-T Recommendation X.200 (1994): "Information technology; Open Systems Interconnection; Basic reference model: The basic model".
- [10] ITU-T Recommendation Q.512 (1995): "Digital exchange interfaces for subscriber access".
- [11] CCITT Recommendation G.812 (1988): "Timing requirements at the outputs of slave clocks suitable for plesiochronous operation of international digital links".

### 3 Definitions, symbols and abbreviations

#### 3.1 Definitions

For the purposes of this ETS the following definitions, together with those given in annex E of ITU-T Recommendation I.430 [1] and in ITU-T Recommendation I.411 [2] apply.

**basic access:** A user-network access arrangement that corresponds to the interface structure composed of two B-channels and one D-channel. The bit rate of the D-channel for this type of access is 16 kbit/s.

**B-channel:** This function provides for the bidirectional transmission of independent B-channel signals each having a bit rate of 64 kbit/s.

**bearer service:** A type of telecommunication service that provides the capability for the transmission of signals between UNI.

NOTE 1: The ISDN connection type used to support a bearer service may be identical to that used to support other types of telecommunication service.

**connection management entity:** An entity for the purpose of management of resources that have an impact on an individual data link connection.

**D-channel:** This function provides for bidirectional transmission of one D-channel signal at a bit rate of 16 kbit/s.

**designated terminal:** A terminal which is permitted to draw power from power source 1 under both normal and restricted power conditions.

**frame alignment:** This function provides information to enable the TE or NT to recover the time-division multiplexed channels.

**Integrated Services Digital Network (ISDN):** A network that provides or supports a range of different telecommunications services and provides digital connections between UNIs.

**interface I<sub>A</sub>:** User side of the ISDN UNI for the basic access.

**interface I<sub>B</sub>:** Network side of the ISDN UNI for the basic access.

**IUT (Implementation Under Test):** Interface point I<sub>B</sub> i.e. NT2 or access connection element (see also ITU-T Recommendation I.430 [1], annex E, clause E.1 definition 109).

**Network Termination (NT):** An equipment providing interface I<sub>B</sub>.

NOTE 2: This term is used in this ETS to indicate network-terminating aspects of NT1, NT2 and PS1 functional groups where these have an I<sub>B</sub> interface.

**Network Termination Type 1 (NT1):** This functional group includes functions broadly equivalent to layer 1 (physical) of the Open Systems Interconnection (OSI) reference model. These functions are associated with the proper physical and electromagnetic termination of the network. NT1 functions are:

- line transmission termination;
- layer 1 maintenance functions and performance monitoring;
- timing;
- power transfer;
- layer 1 multiplexing;
- interface termination, including multidrop termination;
- employing layer 1 contention resolution.



**Network Termination Type 2 (NT2):** This functional group includes functions broadly equivalent to layer 1 and higher layers of the ITU-T Recommendation X.200 [9] reference model. Private Automatic Branch Exchanges (PABXs), Local Area Networks (LANs), and terminal controllers are examples of equipment or combinations of equipment that provide NT2 functions. NT2 functions include:

- layer 2 and 3 protocol handling;
- layer 2 and 3 multiplexing;
- switching;
- concentration;
- maintenance functions;
- interface termination and other layer 1 functions.

**non-designated terminal:** A terminal which is only permitted to draw power from power source 1 under normal power conditions.

**normal power condition:** The condition indicated by the normal polarity of the phantom voltage at the access leads, i.e. where the voltage of the transmit leads c and d on the TE is positive with respect to the voltage on the receive leads e and f.

**Power Source 1 (PS1):** Power source for the provision of remote power feeding of TE via a phantom circuit of the interface wires.

**Rx (Receiver):** Interface signal receiver of IUT or simulator.

**restricted power condition:** The condition indicated by the reversed polarity of the phantom voltage at the access leads, i.e. where the voltage of the receive leads e and f on the TE is positive with respect to the voltage on the transmit leads c and d.

**simulator:** Device generating the stimulus signal for the IUT and monitoring the signal transmitted by the IUT to test the characteristics of NT.

**Terminal Adapter (TA):** An equipment with interface IA and one or more auxiliary interfaces that allow non-ISDN terminals to be served by an ISDN UNI (see also ITU-T Recommendation I.411 [2]).

**Terminal Equipment (TE):** An equipment with interface IA and consisting of one or more functional blocks.

NOTE 3: This term is used in this ETS to indicate terminal-terminating aspects of TE1, TA and NT2 functional groups, where these have an I<sub>A</sub> interface.

**Terminal Equipment Type 1 (TE1):** This functional group includes functions belonging to the functional group TE, and with an interface that complies with the ISDN UNI recommendation.

**Tx (Transmitter):** Interface signal transmitter of IUT or simulator.

### 3.2 Symbols

ONE	Binary "1"
ZERO	Binary "0"

### 3.3 Abbreviations

For the purposes of this ETS, the following abbreviations apply:

APS	Auxiliary Power Supply
dc	direct current
ETS	European Telecommunication Standard
HDLC	High level Data Link Control
I	Informative
I <sub>A</sub>	Interface point A
I <sub>B</sub>	Interface point B
ICS	Implementation Conformance Statement

ISDN	Integrated Services Digital Network
IUT	Implementation Under Test
IXIT	Implementation eXtra Information for Testing
LCL	Longitudinal Conversion Loss
N	Normative
N/R	Not Relevant
NT	Network Termination
ppm	parts per million
PS1	Power Source 1
PS2	Power Source 2
Rx	Receive
Tx	Transmit
UI	Unit Interval (Layer 1)

## 4 Allocation of tests

### 4.1 Scope

Scope	Clause / subclause in ETS 300 012-1 [8]	Test defined in clause / subclause this ETS
Scope	1	N/R

### 4.2 Normative references

Scope	Clause / subclause in ETS 300 012-1 [8]	Test defined in clause / subclause this ETS
Normative references	2	N/R

### 4.3 Definitions, symbols and abbreviations

Definitions, symbols and abbreviations	Clause / subclause in ETS 300 012-1 [8]	Test defined in clause / subclause this ETS
Definitions, symbols and abbreviations	3	N/R
Definitions	3.1	N/R
General definitions	3.1.1	N/R
Interface	3.1.1.1	N/R
NT	3.1.1.2	N/R
TE	3.1.1.3	N/R
Definition of services	3.1.2	N/R
Services required from the physical medium	3.1.2.1	N/R
Services provided to layer 2	3.1.2.2	N/R
Transmission capability	3.1.2.2.1	N/R
Activation/deactivation	3.1.2.2.2	N/R
D-channel access	3.1.2.2.3	N/R
Maintenance	3.1.2.2.4	N/R
Status indication	3.1.2.2.5	N/R
Primitives between layer 1 and other entities	3.1.3	N/R
Modes of operation	3.1.4	N/R
Point-to-point operation	3.1.4.1	N/R
Point-to-multipoint operation	3.1.4.2	N/R
Definitions of states	3.1.5	N/R
TE states	3.1.5.1	N/R
State F1 (inactive)	3.1.5.1.1	N/R
State F2 (sensing)	3.1.5.1.2	N/R
State F3 (deactivated)	3.1.5.1.3	N/R
State F4 (awaiting signal)	3.1.5.1.4	N/R
State F5 (identifying input)	3.1.5.1.5	N/R
State F6 (synchronized)	3.1.5.1.6	N/R
State F7 (activated)	3.1.5.1.7	N/R
State F8 (lost framing)	3.1.5.1.8	N/R
NT states	3.1.5.2	N/R
State G1 (deactive)	3.1.5.2.1	6.3.1
State G2 (pending activation)	3.1.5.2.2	6.3.1
State G3 (active)	3.1.5.2.3	6.3.1
State G4 (pending deactivation)	3.1.5.2.4	6.3.1
Symbols	3.2	N/R
Abbreviations	3.3	N/R

#### 4.4 Primitives associated with layer 1

Primitives associated with layer 1	Clause / subclause in ETS 300 012-1 [8]	Test defined in clause / subclause this ETS
Primitives associated with layer 1	4	N/R

#### 4.5 Wiring configurations and location of interface points

Modes	Clause / subclause in ETS 300 012-1 [8]	Test defined in clause / subclause this ETS
Wiring configurations and location of interface points	5	N/R
General	5.1	N/R
Point-to-point configuration	5.1.1	N/R
Point-to-multipoint configuration	5.1.2	N/R
Location of the interfaces	5.1.3	N/R
Support of wiring configurations	5.2	N/R
Wiring polarity integrity	5.2.1	6.3.2.1.1
NT and TE associated wiring	5.2.2	N/R

#### 4.6 Functional characteristics

Functions	Clause / subclause in ETS 300 012-1 [8]	Test defined in clause / subclause this ETS
Functional characteristics	6	N/R
Interface functions	6.1	N/R
B-channel	6.1.1	5.1
Bit timing	6.1.2	5.1.1
Octet timing	6.1.3	5.1.1
Frame alignment	6.1.4	6.4
D-channel	6.1.5	5.1.1
D-channel access procedure	6.1.6	6.2
Power feeding	6.1.7	8
Deactivation	6.1.8	6.3.3
Activation	6.1.9	6.3.3
Interchange circuits	6.2	5.2.1
Connected/disconnected indication	6.3	N/R
TEs powered across the interface	6.3.1	N/R
TEs not powered across the interface	6.3.2	N/R
Indication of connection status	6.3.3	N/R
Line code	6.4	5.1.1
Frame structure	6.5	5.1
Bit rate	6.5.1	5.1.1
Binary organization of the frame	6.5.2	N/R
TE to NT	6.5.2.1	N/R
NT to TE	6.5.2.2	5.1
Timing considerations	6.6	5.1.1

4.7 Interface procedures

D-channel access	Clause / subclause in ETS 300 012-1 [8]	Test defined in clause / subclause this ETS
Interface procedures	7	N/R
D-channel access procedure	7.1	N/R
Interframe (layer 2) time fill	7.1.1	6.1
D-echo channel	7.1.2	6.2
D-channel monitoring	7.1.3	N/R
Priority mechanism	7.1.4	N/R
Collision detection	7.1.5	N/R

Activation/deactivation	Clause / subclause in ETS 300 012-1 [8]	Test defined in clause / subclause this ETS
Activation/deactivation	7.2	N/R
Activate primitives	7.2.1	6.3
Deactivate primitives	7.2.2	6.3
Management primitives	7.2.3	6.3
Valid primitive sequences	7.2.4	N/R
Signals	7.3	5.1.1, 5.1.2
Activation/deactivation procedure for TEs	7.4	6.3.1
General TE procedures	7.4.1	N/R
Specification of the procedures	7.4.2	N/R
Activation/deactivation for NTs	7.5	6.3
Non-activating/non-deactivating NTs	7.5.1	6.3
Timer values	7.6	6.3.2.3
Activation times	7.7	N/R
TE activation times	7.7.1	N/R
NT activation times	7.7.2	6.3.2.1, 6.3.2.2
Deactivation times	7.8	6.3.2.2

Frame alignment	Clause / subclause in ETS 300 012-1 [8]	Test defined in clause / subclause this ETS
Frame alignment procedures	8	6.4
Frame alignment procedure in the direction NT to TE	8.1	N/R
Loss of frame alignment	8.1.1	N/R
Frame alignment	8.1.2	N/R
Frame alignment in the direction TE to NT	8.2	6.4
Loss of frame alignment	8.2.1	6.4
Frame alignment	8.2.2	6.4
Multi-framing	8.3	N/R
Idle channel code on the B-channels	8.4	N/R

4.8 Electrical characteristics

Functions	Clause / subclause in ETS 300 012-1 [8]	Test defined in clause / subclause this ETS
Electrical characteristics	9	N/R
Bit rate	9.1	7.1
Nominal rate	9.1.1	7.1.1, 7.1.2
Tolerance	9.1.2	7.1.1, 7.1.2
Jitter and bit-phase relationship between TE input and output	9.2	N/R
Test configurations	9.2.1	N/R
Timing extraction jitter	9.2.2	N/R
Total phase deviation input to output	9.2.3	N/R
NT jitter characteristics	9.3	7.2
Termination of the line	9.4	N/R
Transmitter output characteristics	9.5	N/R
Transmitter output impedance	9.5.1	N/R
NT transmitter output impedance	9.5.1.1	7.3
TE transmitter output impedance	9.5.1.2	N/R
Test load impedance	9.5.2	N/R
Pulse shape and amplitude (binary ZERO)	9.5.3	7.4
Pulse shape	9.5.3.1	7.4
Nominal pulse amplitude	9.5.3.2	7.4
Pulse unbalance	9.5.4	N/R
Pulse amplitude when transmitting a high density pattern	9.5.4.1	7.5.1
Pulse unbalance of an isolated couple of pulses	9.5.4.2	7.5.2
Voltage on other test loads (TE only)	9.5.5	N/R
400 $\Omega$ load	9.5.5.1	N/R
5,6 $\Omega$ load	9.5.5.2	N/R
Unbalance about earth	9.5.6	7.6
Longitudinal conversion loss	9.5.6.1	7.6
Output signal balance	9.5.6.2	N/R
Receiver input characteristics	9.6	N/R
Receiver input impedance	9.6.1	N/R
TE receiver input impedance	9.6.1.1	N/R
NT receiver input impedance	9.6.1.2	7.7.1
Receiver sensitivity - Noise and distortion immunity	9.6.2	7.7.2
TEs	9.6.2.1	N/R
NTs for short passive bus (fixed timing)	9.6.2.2	7.7.2
NTs for both point-to-point and short passive bus configurations (adaptive timing)	9.6.2.3	7.7.2
NTs for extended passive bus wiring configurations	9.6.2.4	7.7.2
NTs for point-to-point configurations only	9.6.2.5	7.7.2
NT receiver input delay characteristics	9.6.3	7.7.3
NT for short passive bus	9.6.3.1	7.7.3
NT for both point-to-point and passive bus	9.6.3.2	7.7.3
NT for extended passive bus	9.6.3.3	7.7.3
NT for point-to-point only	9.6.3.4	7.7.3
Unbalance about earth	9.6.4	7.7.4
Isolation from external voltages	9.7	N/R
Interconnecting media characteristics	9.8	N/R
Standard ISDN basis access TE cord	9.9	N/R

## 4.9 Power feeding

Static requirements	Clause / subclause in ETS 300 012-1 [8]	Test defined in clause / subclause this ETS
Power feeding	10	N/R
Reference configuration	10.1	N/R
Functions specified at the access leads	10.1.1	5.1.1, 8.1.1, 8.1.2
Provision of power sources and sinks	10.1.2	8.1.2
Power available from NT	10.2	8.1.4.1
Power source 1 normal and restricted mode	10.2.1	8.1.1, 8.1.2, 8.1.3
Minimum voltage at NT from power source 1	10.2.2	N/R
Normal power conditions	10.2.2.1	8.1.1
Restricted power conditions	10.2.2.2	8.1.2
Minimum voltage of power source 2	10.2.3	8.2
Power available at a TE	10.3	N/R
Power source 1 - phantom mode	10.3.1	N/R
Normal power 1 - phantom mode	10.3.1.1	N/R
Restricted power conditions	10.3.1.2	N/R
Power source 2 - optional third pair	10.3.2	N/R
Normal power conditions	10.3.2.1	N/R
Restricted power conditions	10.3.2.2	N/R
Power source 1 consumption	10.4	N/R
Normal power conditions	10.4.1	N/R
Restricted power conditions	10.4.2	N/R
Power available to a TE "designated" for restricted power operation	10.4.2.1	N/R
Power available to "non-designated" TEs	10.4.2.2	N/R
Galvanic isolation	10.5	N/R

Dynamic requirements	Clause / subclause in ETS 300 012-1 [8]	Test defined in clause / subclause this ETS
Current transient	10.6	N/R
Current/time limitations for TEs	10.6.1	N/R
TE design to minimize power disturbance	10.6.2	N/R
Optimized current/time mask	10.5.2.1	N/R
Alternative current/time mask for optimized TEs	10.6.2.2	N/R
Power source switch-over	10.6.3	N/R
Power source switch-over time	10.6.3.1	8.1.3
Restricted mode power source requirements under overload conditions	10.5.3.2	8.1.4
Other TE requirements	10.6.4	N/R
Minimum TE start-up current	10.6.4.1	N/R
Protection against short term interruptions	10.6.4.2	N/R
Behaviour at switch-over	10.6.4.3	N/R
Other power source requirements	10.6.5	N/R
Power source 1 restricted	10.6.5.1	8.1.4.2, 8.1.4.3, 8.1.4.4
Power source 1 normal	10.6.5.2	N/R
Requirements for type (a) source	10.6.5.3	8.1.5, 9.1.3
Requirements for both types of sources	10.6.5.4	N/R
Switch-on surge capability	10.6.5.4.1	8.1.6, 9.1.4
TE connection surge capability	10.6.5.4.2	8.1.7, 9.1.5
Current unbalance	10.7	N/R
Direct current unbalance	10.7.1	N/R
dc unbalance of power source 1	10.7.1.1	8.1.8
dc unbalance of power sink 1	10.7.1.2	N/R
Differential resistance in a pair of the installation wiring	10.7.1.3	N/R
Current unbalance in a pair	10.7.2	8.1.9, 9.1.6

<b>Requirements for an APS</b>	<b>Clause / subclause in ETS 300 012-1 [8]</b>	<b>Test defined in clause / subclause this ETS</b>
Additional requirements for an APS	10.8	8.1.1, 8.1.2, 8.1.3, 8.1.4.1, 9.1
Power available from an APS	10.8.1	8.1.4.1
APS switch-on time	10.8.2	9.1.1
APS switch-off time	10.8.3	9.1.2
APS power consumption when off	10.8.4	N/R
Dynamic behaviour of an APS	10.8.5	N/R
Additional requirements for NT1 restricted mode source for compatibility with an APS	10.9	9.2
Power source 1 restricted mode back-off	10.9.1	9.2.1
Power source 1 restricted mode power up	10.9.2	9.2.2
NT1 power consumption from APS normal mode	10.9.3	9.2.3

#### 4.10 Interface connector contact assignment

<b>Requirements</b>	<b>Clause / subclause in ETS 300 012-1 [8]</b>	<b>Test defined in clause / subclause this ETS</b>
Interface connector contact assignments	11	5.1.1, 8.1.1, 8.1.2



4.11 Annexes

Requirements	Clause / subclause in ETS 300 012-1 [8]	Test defined in clause / subclause this ETS
Wiring configurations and round trip delay considerations used as a basis for electrical characteristics	Annex A	N/R
Introduction	A.1	N/R
Wiring configurations	A.2	N/R
Point-to-multipoint	A.2.1	N/R
Short passive bus	A.2.1.1	N/R
Extended passive bus	A.2.1.2	N/R
Point-to-point	A.2.2	N/R
Test configurations	Annex B	N/R
Test loopbacks defined for the basic UNI	Annex C	N/R
Introduction	C.1	N/R
Loopback mechanism definitions	C.2	N/R
Test loopback reference configuration	C.3	N/R
Test loopback characteristics	C.4	N/R
Additional requirements applicable to the (explicite) S reference point	Annex D	N/R
Introduction	D.1	N/R
References	D.2	N/R
Definitions	D.3	N/R
Private network termination	D.3.1	N/R
Terminal equipment	D.3.2	N/R
Conformance	D.4	N/R
Requirements	D.5	N/R
Provision of power	D.6	N/R
SDL representation of activation/deactivation procedures for TEs and NTs	Annex F	N/R
SDL representation of activation/deactivation procedures for TEs which can detect power source 1 or power source 2	F.1	N/R
SDL representation of activation/deactivation procedures for NTs	F.2	N/R
Multi-framing mechanism	Annex G	N/R
Multi-framing	G.1	N/R
General mechanism	G.1.1	N/R
Q-bit position identification algorithm	G.1.2	N/R
TE multiframe identification	G.1.3	N/R
S-channel structuring algorithm	G.2	N/R

## 5 Functional characteristic tests

### 5.1 Binary organization of frame

#### 5.1.1 Test A

**Reference:** ETS 300 012-1 [8], subclause 6.5.2.2.

**Purpose:** To check the binary organization of INFO 4 frames.

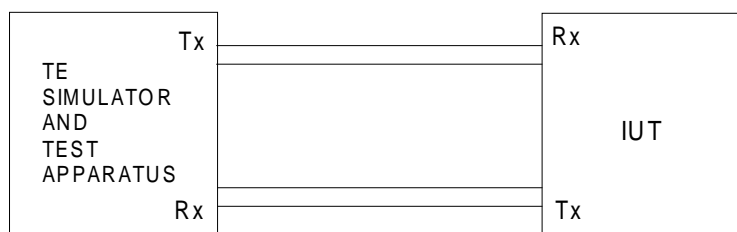

**Figure 1: Test configuration**

**System state:** Active (state G3), with pseudo-random pattern (word length  $\geq 2^9-1$ ) in both B-channels and idle channel code or messages in the D-channel.

**Stimulus:** INFO 3 type frames from the TE simulator.

**Monitor:** The frame structure from the NT (positive pulses, negative pulses and bit and frame timing are available).

**Results:** See table 1.

**Table 1: Results of test**

BIT POSITION	DESCRIPTION	POLARITY
1	F-bit	positive pulse
2	L-bit	negative pulse
3-10	B1 octet	first ZERO coded negative, the following bits may be positive, negative or no pulse
11	E-bit	logically equal to bit 47 of the previous frame in the TE to NT direction
12	D-bit	positive, negative or no pulse
13	A-bit	no pulse
14	$F_A$	negative, positive or in case of multi-framing NT2 no pulse
15	N-bit	opposite binary value of $F_A$ pulse
16-23	B2 octet	positive, negative or no pulse
24	E-bit	logically equal to bit 12 of the frame in the TE to NT direction
25	D-bit	positive, negative or no pulse
26	M-bit	multi-framing bit; negative, positive or in case of multi-framing NT2, no pulse
27-34	B1 octet	positive, negative or no pulse
35	E-bit	logically equal to bit 25 of the frame in the TE to NT direction
36	D-bit	positive, negative or no pulse
37	S-bit	positive or negative pulse
38-45	B2 octet	positive, negative or no pulse
46	E-bit	logically equal to bit 36 of the frame in the TE to NT direction
47	D-bit	positive, negative or no pulse
48	L-bit	positive or no pulse
NOTE 1: L = balance bit which is used to ensure even parity of pulses in one frame.		
NOTE 2: See figure 3, subclause 6.4.2 of ETS 300 012-1 [8] for details of pulse polarity.		
NOTE 3: Multi-framing procedure is not covered by this test.		

5.1.2 Test B

Reference: ETS 300 012-1 [8], subclause 7.3.

Purpose: To check the binary organization of INFO 2 frames.

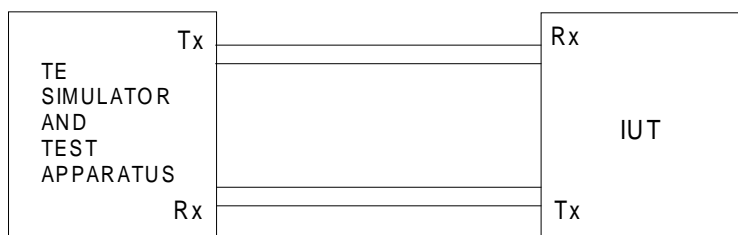

Figure 2: Test configuration

System state: Pending activation (state G2).

Stimulus: Activation request from the TE (INFO 1).

Monitor: Line signals.

Results: Check that the B, D and D-echo channels, bits A, M and S are set to binary ZERO. Bits N and L are set according to the normal coding rules (N and L set to binary ONE).

## 6 Interface procedure tests

These tests are designed to test conformance to the specification of the interface procedures described in ETS 300 012-1 [8], clause 7. The tests are performed by stimulating and monitoring the interface  $I_B$  of an IUT from the bus at the T reference point and by activation requests from the network or the terminal.

### 6.1 D-channel interframe (layer 2) time fill

**Reference:** ETS 300 012-1 [8], subclause 7.1.1.

**Purpose:** To check the D-channel contains the correct interframe time fill from the NT.

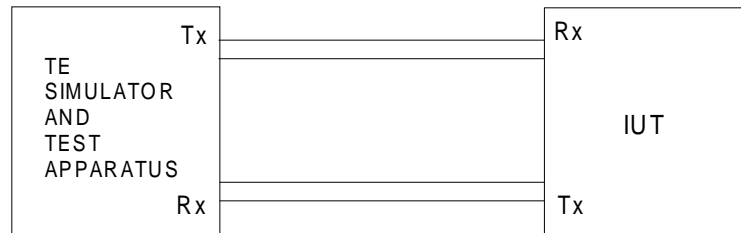

**Figure 3: Test configuration**

**System state:** Active (state G3)

**Stimulus:** INFO 3 from the TE simulator with binary ONE in the D-channel.

**Monitor:** D-channel.

**Results:** Binary ONEs or repetitions of "01111110".

## 6.2 D-echo channel response

**Reference:** ETS 300 012-1 [8], subclause 7.1.2.

**Purpose:** To check that the NT, on receipt of a D-channel bit from the TE simulator, reflects the binary value in the next available D-echo channel bit position towards the TE.

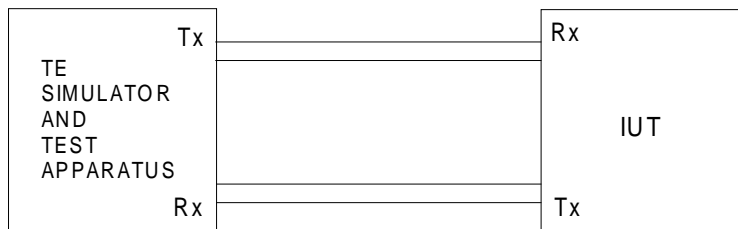

**Figure 4: Test configuration**

**System state:** Active (state G3).

**Stimulus:** INFO 3 from the TE simulator with binary ONES and binary ZEROs in the D-channel.

**Monitor:** Receive D-channel from the TE and transmit D-echo channel by the NT.

**Results:** When the TE simulator sends a D-bit binary ZERO, the returned binary value in the next available D-echo channel bit position towards the TE shall be ZERO.

When the TE simulator sends a D-bit binary ONE, the returned binary value in the next available D-echo channel bit position towards the TE shall be binary ONE.

### 6.3 Activation/deactivation

Reference: ETS 300 012-1 [8], subclause 7.2

#### 6.3.1 Activation/deactivation procedure

Reference: ETS 300 012-1 [8], subclause 7.2.

Purpose: To check the NT correctly executes the activation/deactivation procedure.

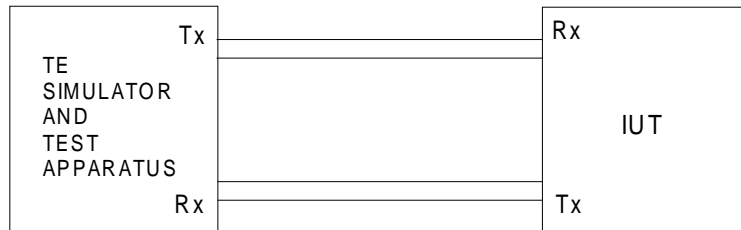

**Figure 5: Test configuration**

System state: Any state.

Stimulus: Line signals INFOs 0, 1 and 3 applied from the TE simulator and activation request (PH-AR) applied from the network.

Monitor: Transmitted line signals, INFOs 0, 2 and 4.

Results: New state, transmitted signal (as described in table 2), and primitives sent to the higher layers according to tables 5, 6 or 7 in ETS 300 012-1 [8].

**Table 2: Stimuli and resulting state changes**

STATE NO	CURRENT STATE	STIMULUS	NOTE	NEXT STATE	INFO SENT	COMMENT
1	G1	PH-AR	5	G2	INFO 2	Initiate activation and timer T1
2	G1	T1 expires		G1	INFO 0	No action
3	G1	T2 expires		G1	INFO 0	No action
4	G1	Rx INFO 0	4	G1	INFO 0	No action
5	G1	Rx INFO 1	5	G2	INFO 2	Activation by the TE and timer T1
6	G2	MPH-DR	2	G4	INFO 0	Initiate deactivation and timer T2
7	G2	T1 expires	2, 5	G4	INFO 0	Initiate deactivation and timer T2
8	G2	T2 expires		G2	INFO 2	No action
9	G2	Rx INFO 0	4	G2	INFO 2	No action
10	G2	Rx INFO 1		G2	INFO 2	No action
11	G2	Rx INFO 3	3	G3	INFO 4	Activate and stop timer T1
12	G3	MPH-DR	2	G4	INFO 0	Initiate deactivation and timer T2
13	G3	T2 expires		G3	INFO 4	No action
14	G3	Rx INFO 0	1, 4	G2	INFO 2	Pending deactivation
15	G3	Rx INFO 3		G3	INFO 4	No action
16	G3	Lost framing		G2	INFO 2	Loss of framing signalling
17	G4	PH-AR	5	G2	INFO 2	Initiate activation and timer T1
18	G4	T1 expires		G4	INFO 0	No action
19	G4	T2 expires	2	G1	INFO 0	Deactivated
20	G4	Rx INFO 0	4	G1	INFO 0	Deactivated
21	G4	Rx INFO 1		G4	INFO 0	No action
22	G4	Rx INFO 3		G4	INFO 0	No action
23	G4	Lost framing		G4	INFO 0	No action

NOTE 1: For testing purposes INFO 0 is simulated by a sinusoidal signal having a voltage of 100 mV peak-to-peak (with a frequency in the range of 2 kHz to 1 MHz).  
 The NT shall react by transmitting INFO 2 within a period time 250 µs to 25 ms.

NOTE 2: In case the value of timer T2 is 0, a direct transition from state G2 or G3 to G1 is possible (note 2 in table 8, subclause 7.7.2 of ETS 300 012-1 [8]).

NOTE 3: A minimum period of 100 ms can elapse before the sending of INFO 4 or sending the primitives PH-AI and MPH-AI (note 2 in table 8, subclause 7.7.2 of ETS 300 012-1 [8]).

NOTE 4: INFO 4 shall be detected when 48 or more contiguous ONEs have been received.

NOTE 5: Timer T1 is a supervisory timer which has to take the overall time to activate into account. This time includes the time it takes to activate both the ET - NT and the NT - TE sections of the customer access. ET is the exchange termination.



### 6.3.2 Activation/deactivation time

Reference: ETS 300 012-1 [8], subclause 7.2.

#### 6.3.2.1 NT activation time

Reference: ETS 300 012-1 [8], subclause 7.7.2.

##### 6.3.2.1.1 Test A in state G1

Reference: ETS 300 012-1 [8], subclause 7.7.2.

Purpose: To check the value of the NT activation time.

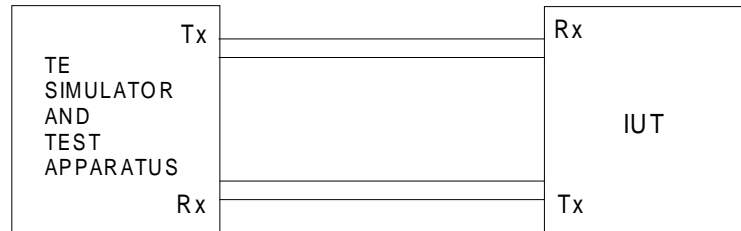

NOTE 1: If the item under test is not a NT2, the test configuration shall also include the subscriber line, the access network and the exchange termination.

**Figure 6: Test configuration**

System state: Deactive state (state G13).

Stimulus: INFO 1 from the TE simulator continuously.

Monitor: The line signals with a digital storing oscilloscope, measuring the elapsed time between start of reception of INFO 1 and transmission of INFO 2.

Results: INFO 2 should be started within 1 s upon the receipt of the first INFO 1.

NOTE 2: Delays "Da" as long as 30 s are acceptable under abnormal conditions (no fault).

6.3.2.1.2 Test B in state G2

Reference: ETS 300 012-1 [8], subclauses 7.7.2 and 5.2.1.

Purpose: To check the value of the NT activation time.

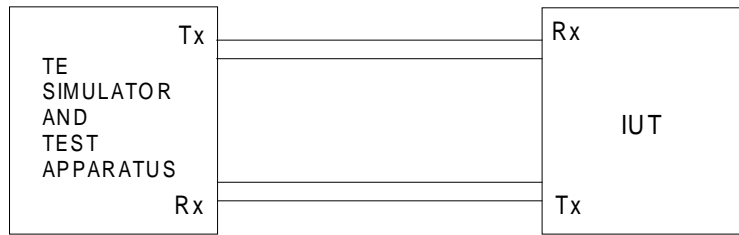

NOTE 1: If the item under test is not a NT2, the test configuration shall also include the subscriber line, the access network and the exchange termination.

Figure 7: Test configuration

System state: Pending activation (state G2).

Stimulus: INFO 3 from the TE simulator.

This test shall be performed with both normal and reversed polarity of the interchange circuit (TE to NT direction).

Monitor: The line signals with a digital storage oscilloscope, measuring the elapsed time between start of receipt of INFO 3 and transmission of INFO 4.

Results: INFO 4 should be started within 1 s upon the receipt of INFO 3.

NOTE 2: Delays "Db" as long as 15 s are acceptable under abnormal conditions (no fault). The sum of delays "Da" and "Db" shall be  $\leq 30$  s (see note 2 of subclause 6.3.2.1.1).

### 6.3.2.2 Deactivation time

**Reference:** ETS 300 012-1 [8], subclause 7.8.

**Purpose:** To check that the NT responds to the receipt of INFO 0 by initiating the transmission of INFO 2 within a period of 250  $\mu$ s to 25 ms.

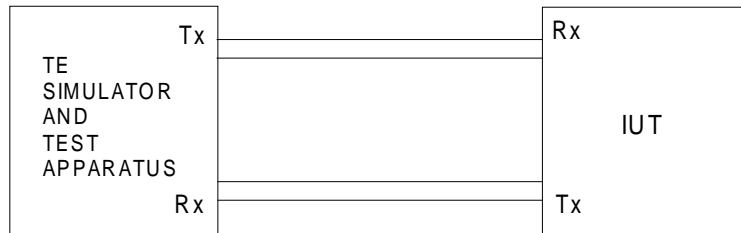

**NOTE:** If the item under test is not a NT2, the test configuration shall also include the subscriber line, the access network and the exchange termination.

**Figure 8: Test configuration**

**System state:** Active (state G3).

**Stimulus:** INFO 0 from the TE simulator (see note 1 in subclause 6.3.1, table 2).

**Monitor:** The line signals with a digital storage oscilloscope, measuring the elapsed time between receiving INFO 0 (cessation of INFO 3) from the TE sending INFO 2 from the NT.

**Results:** INFO 4 ceases (INFO 2 begins) within 250  $\mu$ s and 25 ms.

### 6.3.2.3 Value of the timer T2

**Reference:** ETS 300 012-1 [8], subclause 7.7.2.

**Purpose:** To check the value of the TE activation times in the waiting for signal state.

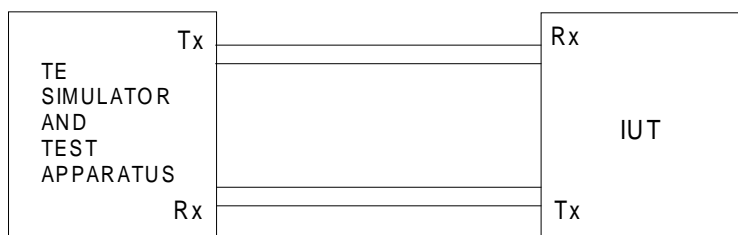

**NOTE:** If the item under test is not a NT2, the test configuration shall also include the subscriber line, the access network and the exchange termination.

**Figure 9: Test configuration**

**System state:** Pending activation (state G2).

**Stimulus:** Expiration of timer T1.  
INFO 1 from the TE simulator.

**Monitor:** The line signals with a digital storage oscilloscope, measuring the elapsed time between the cessation of INFO 2 and sending another INFO 2.

**Results:**  $25 \text{ ms} \leq T2 \leq 100 \text{ ms}$ .

#### 6.4 Frame alignment procedures

**Reference:** ETS 300 012-1 [8], clause 8.

**Purpose:** To test that the NT correctly executes the frame alignment procedures (enters frame alignment).

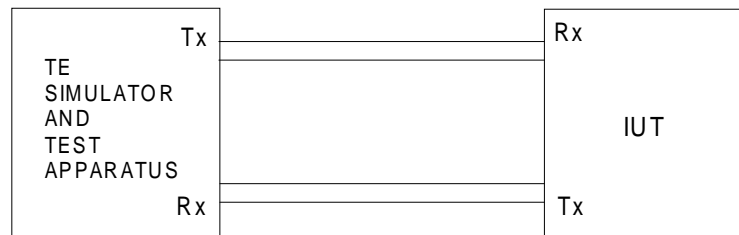

**Figure 10: Test configuration**

**System state:** Active (state G3).

**Stimulus:** Good/bad frames from the TE simulator.

**NOTE 1:** A bad frame is simulated by any bit pattern with violation of the coding rules on which the IUT conforming to subclause 8.1.2 of ETS 300 012-1 [8] is not able to detect the frame alignment.

**NOTE 2:** The start of a frame is defined to the position where the F-bit according to figure 3 in ETS 300 012-1 [8] should appear.

**Monitor:** Received and transmitted line signals.

**Results:** Line signals according to table 3.

**Table 3: Framing procedures; stimuli and resulting line signals at the network simulator**

	<b>Stimulus</b>	<b>Results</b>	<b>Comments</b>
a)	1 bad frame (note 1)	INFO 4	No loss of framing
b)	5 bad frames (see note 1)	INFO 2	Framing lost
c)	2 good frames (see note 2)	INFO 2	Framing not regained
d)	6 good frames (see notes 2 and 3)	INFO 4	Framing regained within 5 frames
NOTE 1: Before the commencement of the test, the NT shall be in system state G3.			
NOTE 2: Before the test, the NT shall not be in state G3.			
NOTE 3: Multi-framing procedure is not covered by this test.			

## 7 Electrical characteristics tests

**Reference:** ETS 300 012-1 [8], clause 9.

These tests are designed to check that the interface conforms to the electrical characteristics specified in Clause 9 of ETS 300 012-1 [8].

Many of these tests require the interface to be stable in the activated state and transmitting a specific bit pattern, with or without the connection to the TE. As none of these requirements can be met with the TE simulator operating normally, it is anticipated that special arrangements shall be made to permit this, for example the receiving section to the TE simulator could be set in the appropriate state manually.

### 7.1 Bit rate

**Reference:** ETS 300 012-1 [8], subclause 9.1.

#### 7.1.1 Bit rate when transmitting an INFO 2

**Reference:** ETS 300 012-1 [8], subclauses 9.1.1 and 9.1.2.

**Purpose:** The average bit rate when the NT is transmitting INFO 2 type frames.

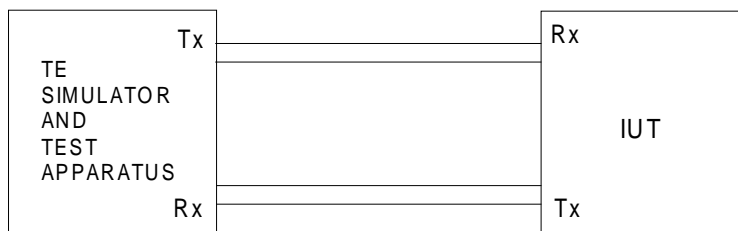

**NOTE:** If the item under test is not a NT2, the test configuration shall also include the subscriber line, the access network and the exchange termination.

**Figure 11: Test configuration**

- System state:** Pending activation (state G2).
- Stimulus:** INFO 1 type frames from the TE simulator.
- Monitor:** Bit rate.
- Results:**
- a) Basic rate access element:  
nominal bit rate of 192 kHz (related to the network clock accuracy is given in ITU-T Recommendations Q.512 [10] and G.812 [11] as far as the  $I_B$  point is concerned).
  - b) NT2 in free running mode:  
bit rate of 192 kHz  $\pm$  100 ppm.

### 7.1.2 Bit rate when transmitting an INFO 4

**Reference:** ETS 300 012-1 [8], subclause 9.1.1 and 9.1.2

**Purpose:** The average bit rate when the NT is transmitting INFO 4 type frames.

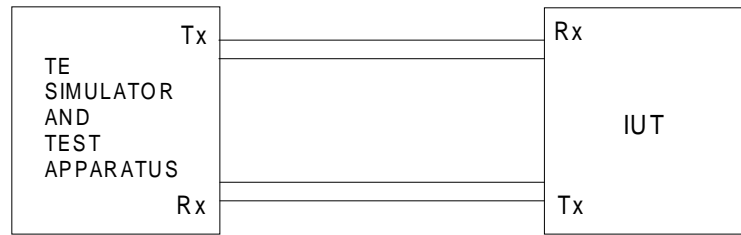

**NOTE:** If the item under test is not a NT2, the test configuration shall also include the subscriber line, the access network and the exchange termination.

**Figure 12: Test configuration**

**System state:** Active (state G3).

**Stimulus:** INFO 3 type frames from the TE simulator.

**Monitor:** Bit rate.

**Results:**

- a) Basic rate access element:  
nominal bit rate of 192 kHz (related to the network clock accuracy is given in ITU-T Recommendations Q.512 [10] and G.812 [11] as far as the  $I_B$  point is concerned).
- b) NT2 in free running mode:  
bit rate of 192 kHz  $\pm$  100 ppm.

## 7.2 NT jitter characteristics

Reference: ETS 300 012-1 [8], subclause 9.3.

Purpose: NT output jitter when transmitting INFO 4.

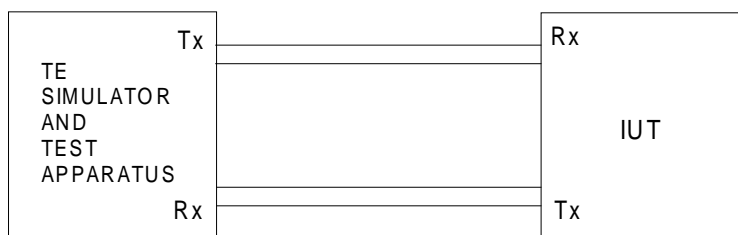

Figure 13: Test configuration

System state: Active (state G3).

When IUT sending:

- a) ONEs in D and both B-channels;
- b) a sequence consisting of a pseudo random pattern with a length of  $2^{19}-1$  in D and both B-channels (see note).

Stimulus: INFO 3 type frames from the TE simulator with pseudo random pattern with a length of  $2^{19}-1$  in D-channel and with the stimulating signal to the interface from which the timing will be derived containing the maximum tolerable jitter at the synchronizing input of the IUT.

Monitor: The jitter should be measured using a high pass filter having a cut-off frequency (3 dB point) of 50 Hz and an asymptotic roll-off of 20 dB per decade.

Results: The maximum jitter (peak to peak) shall be less than  $\pm 5\%$  of a bit period.

NOTE: For testing purpose of NT2, a fixed pattern in D-channel can be acceptable (binary ONE or flags).



### 7.3 NT transmitter output impedance

**Reference:** ETS 300 012-1 [8], subclause 9.5.1.1.

**NOTE:** NT transmitting pair connected without its terminating resistor.

#### 7.3.1 Test A

**Reference:** ETS 300 012-1 [8], subclause 9.5.1.1.

**Purpose:** Output impedance of the transmitters when transmitting a binary ONE (no signal).

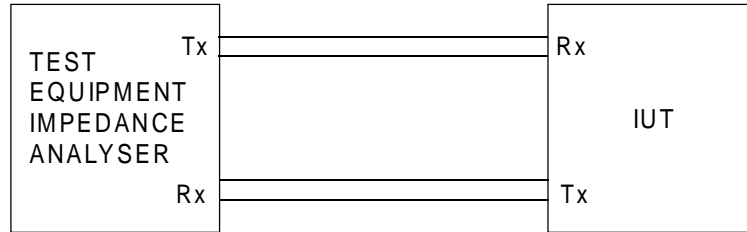

**Figure 14: Test configuration**

If the IUT provides PS1 normal, condition a) shall be used, otherwise condition b).

- a) using configuration with maximum power (at least 1 W) from power source 1 in normal power condition;
- b) using configuration with maximum power (420 mW) drawn from power source 1 in restricted power condition.

**System state:** Deactive (state G1).

**Stimulus:** Sinusoidal voltages of 100 mV rms, in the frequency range 2 kHz to 1 000 kHz.

**Monitor:** Impedance.

**Results:** The measured value shall exceed the impedance template given in figure 11 of ETS 300 012-1 [8] subclause 9.5.1.1.

7.3.2 Test B

Reference: ETS 300 012-1 [8], subclause 9.5.1.1.

Purpose: Output impedance of the transmitters when transmitting ZERO.

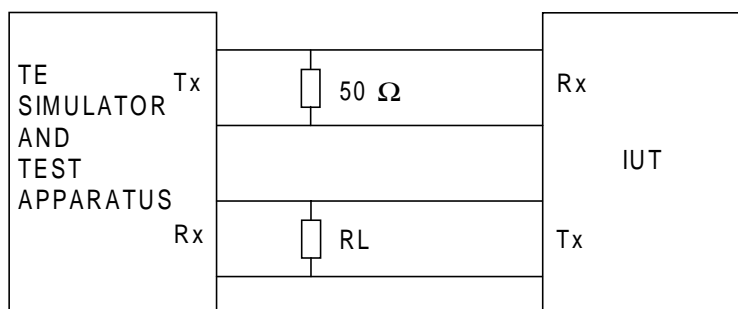

Figure 15: Test configuration

If the IUT provides PS1 normal, condition a) shall be used, otherwise condition b).

- a) using configuration with maximum power (at least 1 W) from power source 1 in normal power condition;
- b) using configuration with maximum power (420 mW) drawn from power source 1 in restricted power condition.

System state: Active (state G3).

Stimulus: INFO 3.

Monitor: Both positive and negative pulses.

The output impedance limit shall apply for a nominal load impedance (resistive) conditions :  $R_L = 50 \Omega$ . The output impedance for this nominal load is defined by determining the peak pulse amplitude for loads equal to the nominal value  $\pm 10 \%$ . The peak amplitude is defined as the amplitude of the midpoint of the pulse. The test applies for pulses of both polarities.

Results: The output impedance shall be  $\geq 20 \Omega$

$$R = \frac{U^+ - U^-}{U^- / R^- - U^+ / R^+}$$

- R<sup>+</sup>: nominal resistance RL + 10 %.
- R<sup>-</sup>: nominal resistance RL - 10 %.
- U<sup>+</sup>: peak amplitude when R<sup>+</sup> is applied.
- U<sup>-</sup>: peak amplitude when R<sup>-</sup> is applied.

## 7.4 Pulse shape and amplitude

**Reference:** ETS 300 012-1 [8], subclause 9.5.3.

**Purpose:** Pulse shape and amplitude of isolated transmitted pulses.

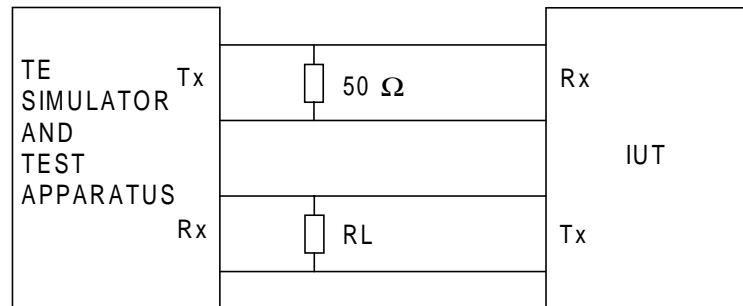

**NOTE:** IUT interface transmitting pair terminated in 50 Ω.

**Figure 16: Test configuration**

**System state:** Active (state G3).

IUT transmitting isolated pulses (no adjacent pulses) into a normally terminated bus.

**Stimulus:** INFO 3.

**Monitor:** Both positive and negative pulses.

**Results:** Both positive and negative pulses shall be within the mask given in figure 13 of ETS 300 012-1 [8] with a nominal amplitude of 750 mV zero to peak (see also subclause 9.5.3.1 in ETS 300 012-1 [8]).

## 7.5 Pulse unbalance

Reference: ETS 300 012-1 [8], subclause 9.5.4.

### 7.5.1 Pulse amplitude

Reference: ETS 300 012-1 [8], subclause 9.5.4.1.

Purpose: Pulse amplitude when transmitting a high density pattern.

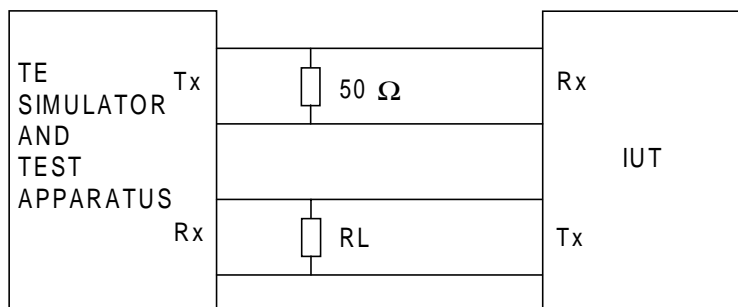

NOTE: IUT interface transmitting pair terminated in 50 Ω.

**Figure 17: Test configuration**

System state: Pending activation (state G2).

Stimulus: INFO 1.

Monitor: The amplitude of positive and negative pulses at the midpoint of the pulse.

Results: The measured amplitude in the midpoint of the pulse shall be within the  $\pm 10\%$  of the nominal amplitude values. The measurement shall be done on 40 continuous frames.

### 7.5.2 Pulse unbalance of an isolated couple of pulses

**Reference:** ETS 300 012-1 [8], subclause 9.5.4.2.

**Purpose:** The relative difference in  $\int U(t)dt$  for a positive and negative pulses.

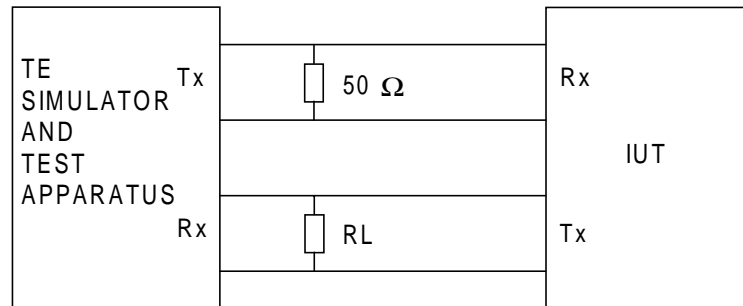

**NOTE:** IUT interface transmitting pair terminated in 50 Ω.

**Figure 18: Test configuration**

**System state:** Active (state G3)  
IUT transmitting INFO 4 (see note).

**NOTE:** For NTs conformance test shall be done with the signal INFO 4. In the B1-channel two alternated octets 1111 1111 and 1111 1100 shall be inserted so that the two binary ZEROs are set in the bit positions 33 and 34 (see table 3 in ETS 300 012-1 [8]). All B2-, D- and E-bits shall be set to binary ONE.

**Stimulus:** INFO 3.

**Monitor:** a) voltage when transmitting INFO 0.  
b) isolated couple of pulses.

**Results:** The absolute sum (note) in  $\int U(t)dt$  for a positive pulse and the  $\int U(t)dt$  for a negative pulse shall be less than or equal to 5 % of the nominal pulse. The zero reference voltage is given by the signal when transmitting INFO 0.

**NOTE:** The edge between the two adjacent pulses is the crossing of the zero voltage. From this edge, the integral is defined for a time period of 1,5 UI in each direction.

7.6 Longitudinal conversion loss of transmitter output

Reference: ETS 300 012-1 [8], subclause 9.5.6.1.

Purpose: Longitudinal Conversion Loss (LCL) (the ratio of longitudinal signal converted to a transverse signal as a result of lthe unbalance about earth of the output of the Item Under Test).

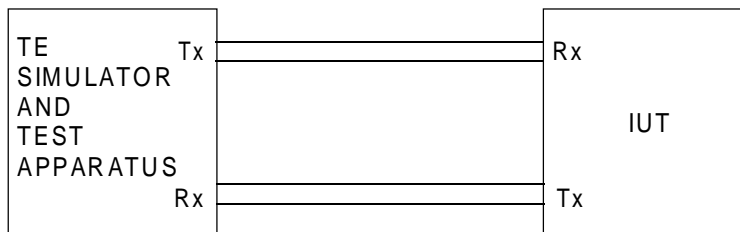

Figure 19: Test configuration

System state: Deactivated (state G1).

Stimulus: 1 V rms longitudinal in accordance with figure 15 in ETS 300 012-1 [8].

Monitor: Transverse voltage in accordance with figure 15 in ETS 300 012-1 [8] with selective level measuring instrument.

Results: Longitudinal conversion loss according to table 4.

Table 4: Longitudinal conversion loss

Frequency	Longitudinal conversion loss
$10 \text{ kHz} \leq f \leq 300 \text{ kHz}$	$\geq 54 \text{ dB}$
$300 \text{ kHz} \leq f \leq 1 \text{ MHz}$	Minimum value decreasing from 54 dB at 20 dB/decade.

## 7.7 Receiver input characteristics

**Reference:** ETS 300 012-1 [8], subclause 9.6.

### 7.7.1 NT receiver input impedance

**Reference:** ETS 300 012-1 [8], subclause 9.6.1.2.

NOTE: NT receiving pair connected without terminating resistor.

#### 7.7.1.1 Test A

**Reference:** ETS 300 012-1 [8], subclause 9.6.1.2.

Purpose: To test the input impedance of a NT whilst in a deactive state.

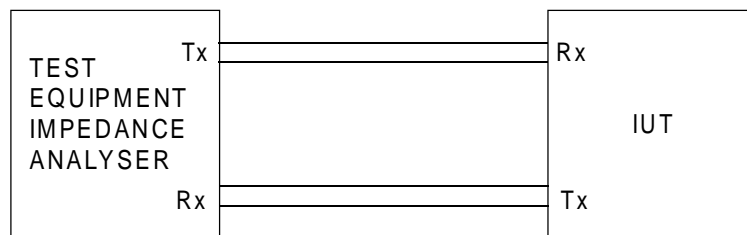

**Figure 20: Test configuration**

If the IUT provides PS1 normal, the condition a) shall be used, otherwise condition b).

- a) using configuration with maximum power (at least 1 W) from Power Source 1 in normal power condition.
- b) using configuration with maximum power (420 mW) drawn from Power Source 1 in restricted power condition.

System state: Deactivated (state G1).

Stimulus: Sinusoidal voltage of at least 100 mV rms, in the frequency range 2 kHz to 1 000 kHz.

Monitor: Impedance.

Results: Shall exceed the impedance template of figure 12 in ETS 300 012-1 [8].

7.7.1.2 Test B

Reference: ETS 300 012-1 [8], subclause 9.6.1.2.

Purpose: To test that the input impedance of the receiver is correct when receiving an overvoltage signal.

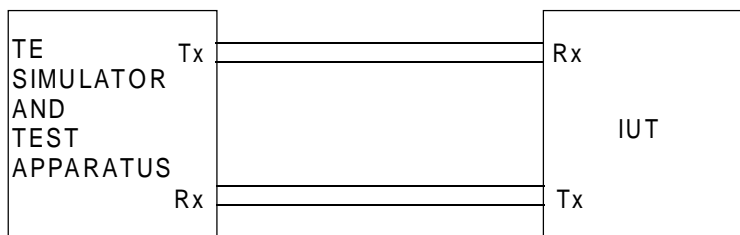

Figure 21: Test configuration

If the IUT provides PS1 normal, the condition a) shall be used, otherwise condition b).

- a) using configuration with maximum power (at least 1 W) from Power Source 1 in normal power condition.
- b) using configuration with maximum power (420 mW) drawn from Power Source 1 in restricted power condition.

System state: Deactivated (state G1).

Stimulus: Sinusoidal voltage up to 1,2 V (peak value) at a frequency of 96 kHz (the applied voltage to be monitored to ensure peak values are correct).

Monitor: Peak value of input current.

Results: The peak current shall not exceed 0,6 mA peak value.



### 7.7.2 Receiver sensitivity - noise and distortion immunity

**Reference:** ETS 300 012-1 [8], subclause 9.6.2.

**Purpose:** Subclause 9.6.2 of ETS 300 012-1 [8] is designed to correctly test the receiver's function in the various wiring configurations.

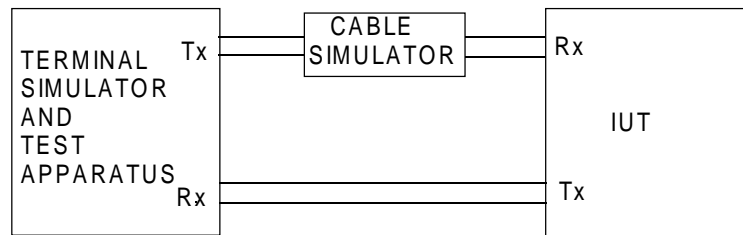

**Figure 22: Test configuration**

**System state:** Active (state G3).

**Stimulus:** Input signals are transmitted from the terminal simulator with a pseudo-random sequence (word length  $\geq 511$  bits) in both B-channels with amplitudes, delay and interfering signals as detailed in subclauses 9.6.2.2 to 9.6.2.5 in ETS 300 012-1 [8].

When performing this test the error rate measurement can be made either after the receiver using a B-channel access port or at the IUT transmitter. If the measurement is at the NT transmitter, then the connection to the TE simulator should be made through a time delay corresponding to the bus configuration used.

Table 5 indicates the amplitudes that are provided by the NT simulator corresponding to the bus configurations as given in subclause 9.2.1.

**Table 5: Amplitudes corresponding to the bus configurations**

Condition on NT	Clause/subclause	Configuration	Amplitude relative to the nominal one
For short passive bus	9.6.2.2 (A.8.6.2.2)	ii and iii	-1,5 dB and +1,5 dB at the TE output
For point-to-point and short passive bus (see notes 1 and 2)	9.6.2.3 (A.8.6.2.3)	i	-1,5 dB at the TE simulator output
		ii	-1,5 dB and +1,5 dB at the TE output
		iii	-1,5 dB and +1,5 dB at the TE output
		iv	+1,5 dB at the TE simulator output
For extended bus (see note 2)	9.6.2.4 (A.8.6.2.4)	iv	+1,5 dB at the TE simulator output
		(note 3)	-1,5 dB at the TE simulator output
For point-to-point (see notes 1 and 2)	9.6.2.5 (A.8.6.2.5)	i	-1,5 dB at the TE simulator output
		iv	+1,5 dB at the TE simulator output
NOTE 1:	In addition, for each configuration jitter at frequencies of 5 Hz/0,5 UI, 20 Hz/0,125 UI, 50 Hz/0,05 UI and 2 015 Hz/0,05 UI shall be superimposed on the input signal.		
NOTE 2:	Additionally the IUT shall operate with sinusoidal signals having an amplitude of 100 mV (peak to peak) at frequencies of 200 kHz and 2 MHz superimposed individually on the input signals.		
NOTE 3:	This configuration consists of a cable having a characteristic impedance of 75 $\Omega$ , a capacitance of 120 nF/km, a loss of 3,8 dB at 96 kHz, four TEs connected such that the differential delay is at the maximum permitted by subclause 9.6.3.3, in ETS 300 012-1 [8].		

**Monitor:** B-channels from IUT checking the error rate (see clause 1).

**Results:** No error for a monitoring period of at least one minute.

7.7.3 NT receiver input delay characteristics

Reference: ETS 300 012-1 [8], subclause 9.6.3.

Purpose: Test of error free transmission with permitted round trip delay.

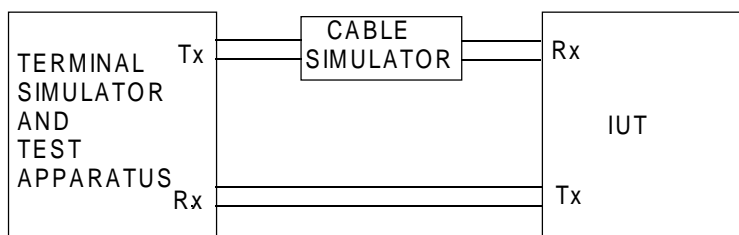

Figure 23: Test configuration

System state: Pending activation (state G2).

Table 6: Round trip delay of the bus configurations

Condition on NT	Clause/ subclause	Configuration	Round trip delay
For short passive bus	9.6.3.1 (A.8.6.3.1)	ii and iii	10 μs to 14 μs
For point-to-point and short passive bus	9.6.3.2 (A.8.6.3.2)	i ii an iii	10 μs to 42 μs 10 μs to 13 μs
For extended bus	9.6.3.3 (A.8.6.3.3)	see note	10 μs to 42 μs
For point-to-point	9.6.3.4 (A.8.6.3.4)	i	10 μs to 42 μs
NOTE: This configuration consists of a cable having a characteristic impedance of 75 Ω, a capacitance of 120 nF/km, a loss of 3,8 dB at 96 kHz, four TEs connected such that the differential delay of signals from different TEs is in the range from 0 to 2 μs.			

Stimulus: INFO 3 from the TE simulator.

A pseudo-random sequence (word length ≥ 511 bits) in both B-channels.

When performing this test the error rate measurement can be made either after the receiver using a B-channel access port or at the IUT transmitter. If the measurement is at the NT transmitter, then the connection to the TE simulator should be made through a time delay corresponding to the bus configuration used.

Monitor: Transmitting line signals from the IUT

Results: IUT shall go to state G3. No error for a monitoring period of at least one minute.

**7.7.4 Unbalance about earth of the receiver input**

**Reference:** ETS 300 012-1 [8], subclause 9.6.4.

**Purpose:** Longitudinal Conversion Loss (LCL) (the ratio of longitudinal signal converted to a transverse signal as a result of the unbalance about earth of the output of the IUT).

**NOTE:** NT receiver pair connected without terminating resistors.

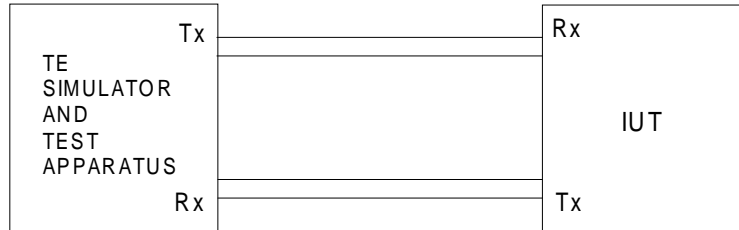

**Figure 24: Test configuration**

**System state:** Deactive (state G1) and active (state G3).

**Stimulus:** 1 V rms longitudinal in accordance with figure 15 in ETS 300 012-1 [8].

**Monitor:** Transverse voltage in accordance with figure 15 in ETS 300 012-1 [8] with selective level measuring instrument.

**Results:** Longitudinal conversion loss according to table 7.

**Table 7: Longitudinal conversion loss**

Frequency	Longitudinal conversion loss
$10 \text{ kHz} \leq f \leq 300 \text{ kHz}$	$\geq 54 \text{ dB}$
$300 \text{ kHz} \leq f \leq 1 \text{ MHz}$	Minimum value decreasing from 54 dB at 20 dB/decade.

## 8 Power feeding

### 8.1 Power source 1

Reference: ETS 300 012-1 [8], subclause 10.2.2.

#### 8.1.1 Normal power condition

Reference: ETS 300 012-1 [8], subclause 10.2.2.1.

NOTE: This requirement also applies to the APS.

Purpose: To ensure that the NT, whilst in normal power condition, is feeding enough power to the S/T-bus from the local power supply and to test the tolerance of the feeding voltage.

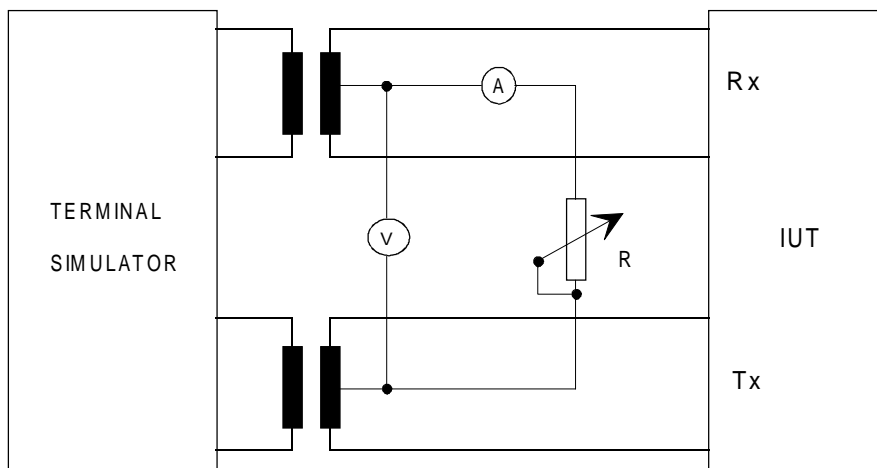

Figure 25: Test configuration

System state: Any state.

Stimulus: Drawing no power and the maximum power provided by PS1 as declared by the apparatus supplier. Reduce the resistance from  $\infty \Omega$  to a value, so that the maximum power is available.

Monitor: dc voltage and current.

Results: The voltage at the output of the source shall be 40 V, +5 %, -15 %.

### 8.1.2 Restricted power provision

**Reference:** ETS 300 012-1 [8], subclause 10.2.2.2.

**Purpose:** To ensure that the NT, under restricted power condition, is feeding enough power to the S/T-bus from the line and to test the open circuit voltage.

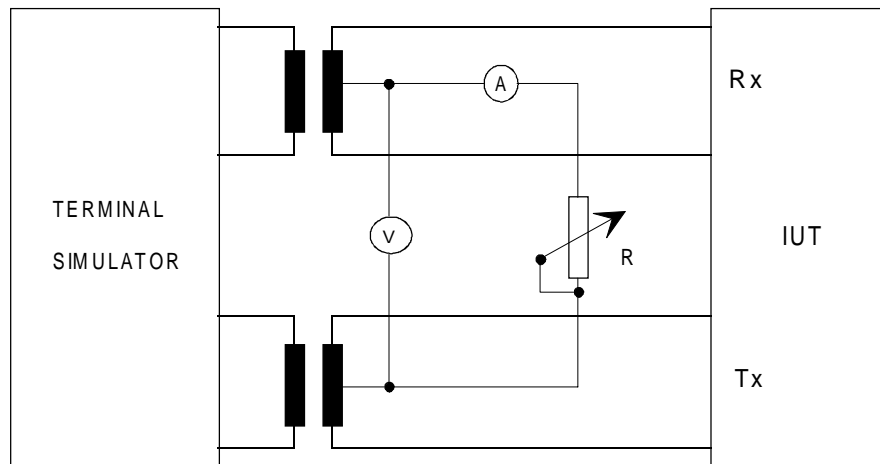

**Figure 26: Test configuration**

**System state:** Any state.

**Stimulus:** Drawing no power and the maximum power provided by PS1 as declared by the apparatus supplier. Reduce the resistance from  $\infty \Omega$  to a value, so that the maximum power is available.

**Monitor:** dc voltage and current.

**Results:** The voltage at the output of the source shall be 40 V, +5 %, -15 % (reversed polarity).

### 8.1.3 Power source switch-over time

Reference: ETS 300 012-1 [8], subclause 10.6.3.1.

Purpose: To test the switch-over time.

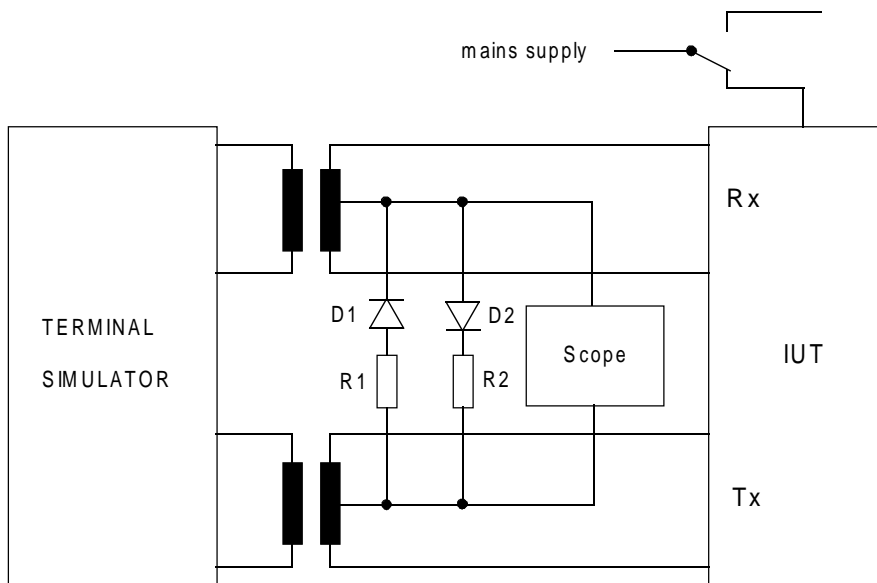

NOTE: The power consumption of D1 and R1 represents a load of 420 mW (restricted mode).  
The power consumption of D2 and R2 represents a load of  $n \times 1$  W (normal mode).

**Figure 27: Test configuration**

System state: Any state.

Stimulus: Connection or disconnection of mains supply.

Monitor: Output voltage versus time.

Results: The transition time of voltage between +34 V and -34 V (or vice versa) shall be less than 5 ms.

### 8.1.4 Power source 1 restricted mode under overload conditions

#### 8.1.4.1 Test A (E.5.1.4.1)

**Reference:** ETS 300 012-1 [8], subclause 10.6.3.2.

**Purpose:** Restricted mode power source requirements under overload conditions (short circuit current).

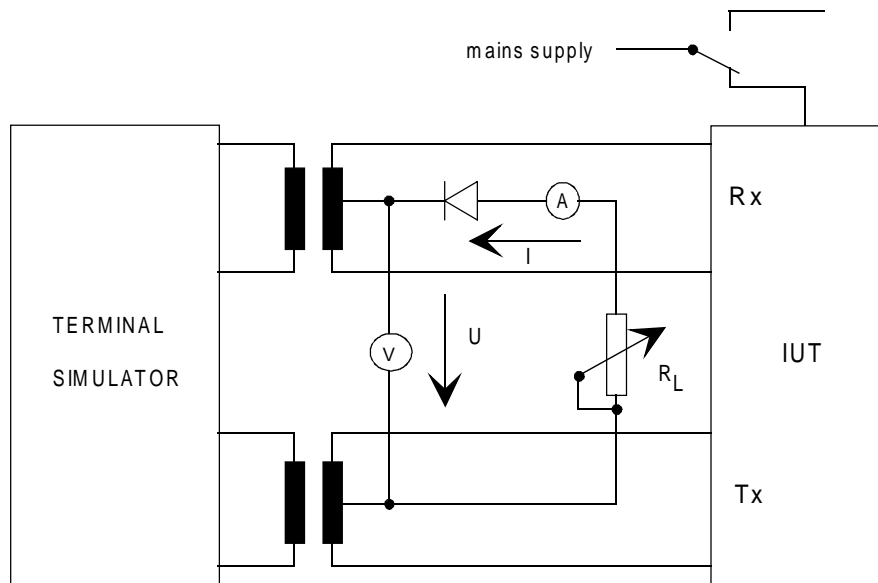

**Figure 28: Test configuration**

**System state:** Any state.

**Stimulus:** Disconnection of mains supply and adjustment of the resistor  $R_L$  so that the voltage  $U$  is forced to a value  $\leq 1$  V.

**Monitor:** Output current.

**Results:** Minimal output current equal or greater than 9 mA at output voltage less than 1 V. This output current is measured for 1 s after the switch over is completed.

8.1.4.2 Test B

Reference: ETS 300 012-1 [8], subclause 10.6.3.2.

Purpose: Restricted mode power source requirements under overload conditions (load resistance increasing from short circuit).

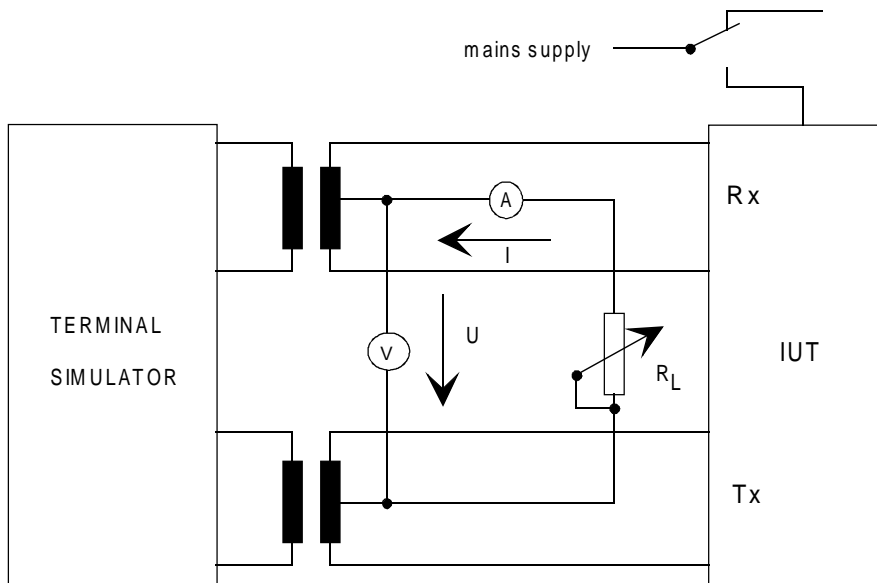

Figure 29: Test configuration

System state: Any state.

Stimulus: Increasing load resistor  $R_L$  starting with short-circuit.

Monitor: Output current, output voltage.

Results: Output current shall be  $I \geq 11 \text{ mA}$  at output voltage of  $U = 34 \text{ V}$ .



8.1.4.3 Test C

Reference: ETS 300 012-1 [8], subclause 10.6.3.2.

Purpose: Restricted mode power source requirements under overload conditions (load resistance decreasing from nominal output power).

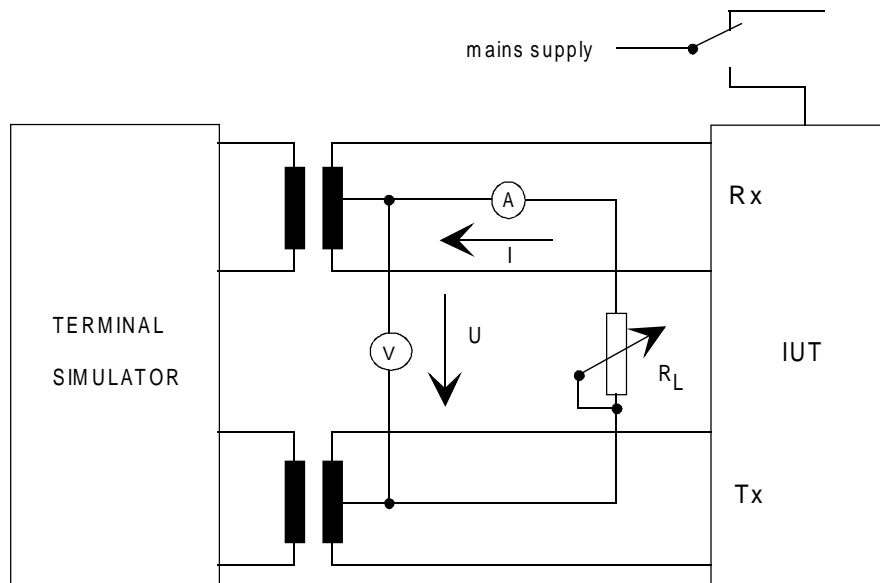

Figure 30: Test configuration

System state: Any state.

Stimulus: Decreasing load resistor  $R_L$  starting with load for nominal power output.

Monitor: Output current, output voltage.

Results: Output current shall be  $I \geq 11 \text{ mA}$  at output voltage of  $U = 34 \text{ V}$ .

8.1.4.4 Test D

Reference: ETS 300 012-1 [8], subclause 10.6.5.1.

Purpose: Capability to increase output voltage under capacitive load in restricted mode.

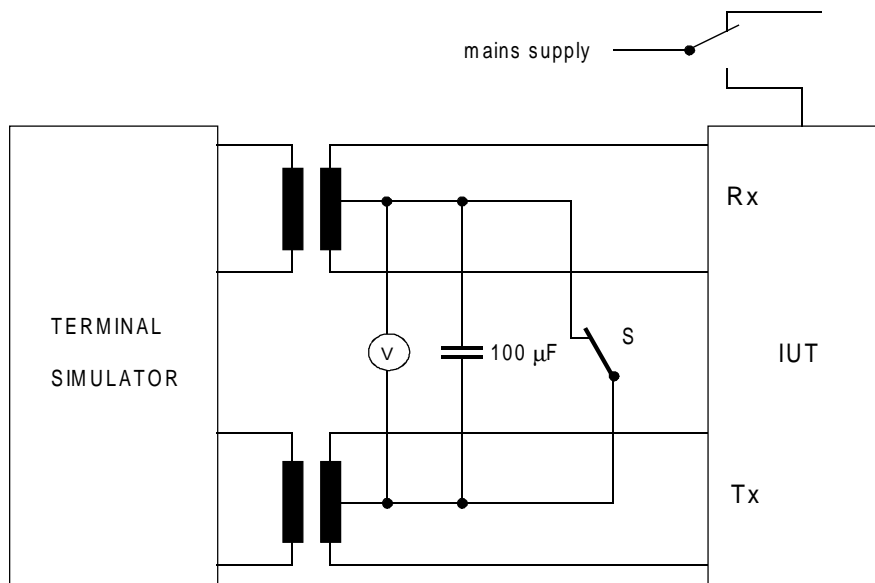

Figure 31: Test configuration

System state: Any state.

Stimulus: Short circuit for 30 minutes then removal of short circuit (switch off S).

Monitor: Output voltage under capacitive load of 100 µF.

Results: The output voltage shall increase from 1,0 V to 34 V within 1,5 s. This shall occur within 10 s after the removal of the short circuit.

8.1.5 Requirements for type "a" sources

Reference: ETS 300 012-1 [8], subclause 10.6.5.3.

Purpose: To test requirements for the voltage increase of a power source 1 normal, with fall-back characteristics, after the removal of a short circuit.

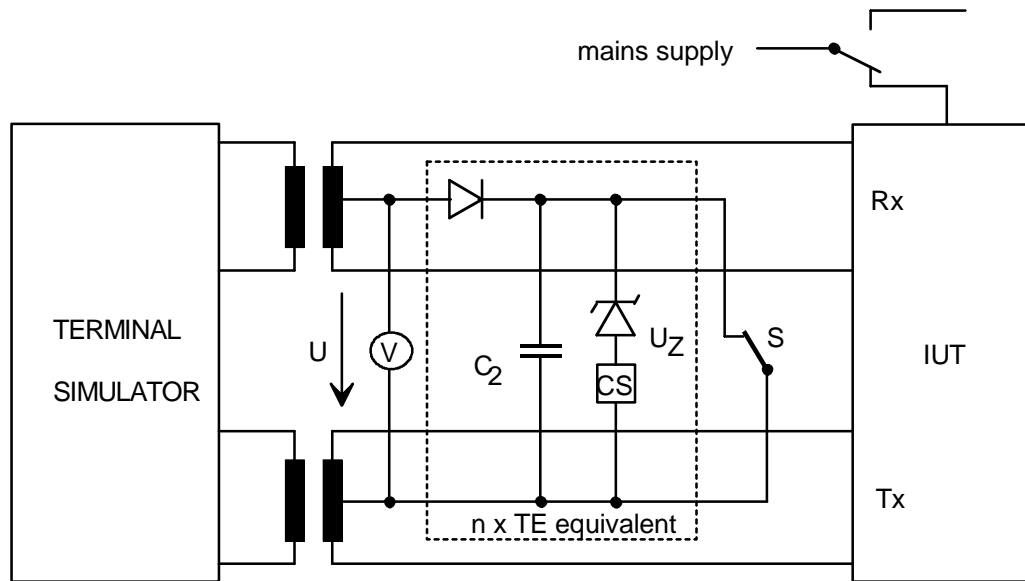

NOTE: CS = 15 mA,  $U_Z = 24$  V,  $C_2 = 100$   $\mu$ F

Figure 32: Test configuration

System state: Any state.

Stimulus: Lowest acceptable voltage level at mains interface, short circuit steady state of 30 minutes, removal of short circuit (switch off S), with a load of  $n \times$  TE-equivalents as given in figure 23 in ETS 300 012-1 [8].

Monitor: Output voltage under n-times TE-equivalents.

Results: The output voltage shall increase from 1,0 V to 34 V within 350 ms. This shall occur within 10 s after the removal of the short circuit.

8.1.6 Switch on surge capability

Reference: ETS 300 012-1 [8], subclause 10.6.5.4.1.

Purpose: Switch on surge capability, power source 1 in normal mode.

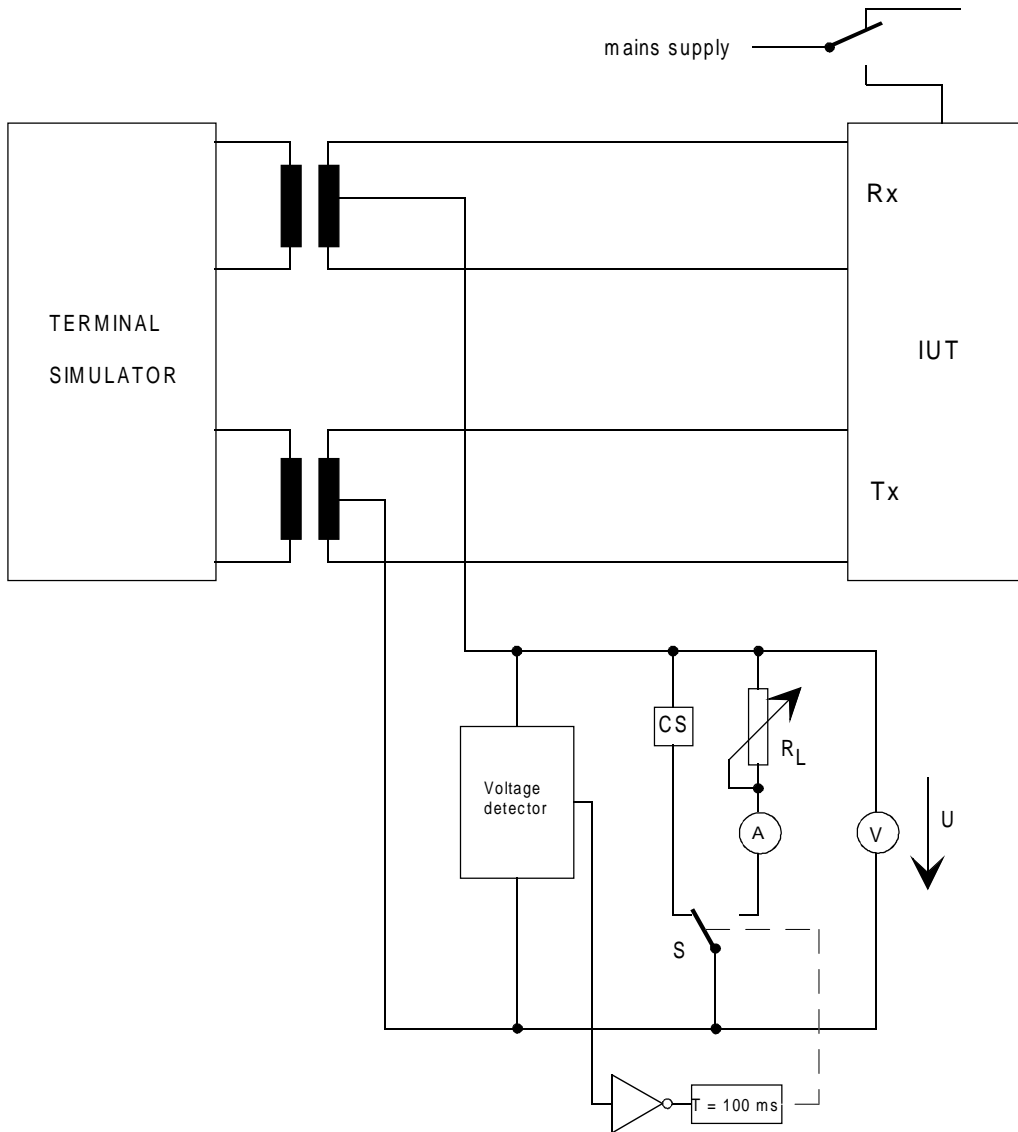

NOTE: If restricted power is provided prior to switch over to normal mode, protection of the current sink may be required.

Figure 33: Test configuration

- System state: Any state.
- Stimulus: Connection of mains supply.
- Monitor: Output voltage versus time.
- Results: The power source 1 shall provide a minimum current of  $n \times 45 \text{ mA}$  (CS) for at least 100 ms and the voltage shall be at least 30 V during this time period. After the time of 100 ms, the power source shall be able to provide the power of  $n \times 1 \text{ W}$  ( $R_L$ ) and the drop of power on the interface with the output voltage shall be within the specified limits.

**8.1.7 TE connection surge capability**

**Reference:** ETS 300 012-1 [8], subclause 10.6.5.4.2.

**Purpose:** TE connection surge capability in normal mode.

**NOTE:** This requirement also applies to the APS.

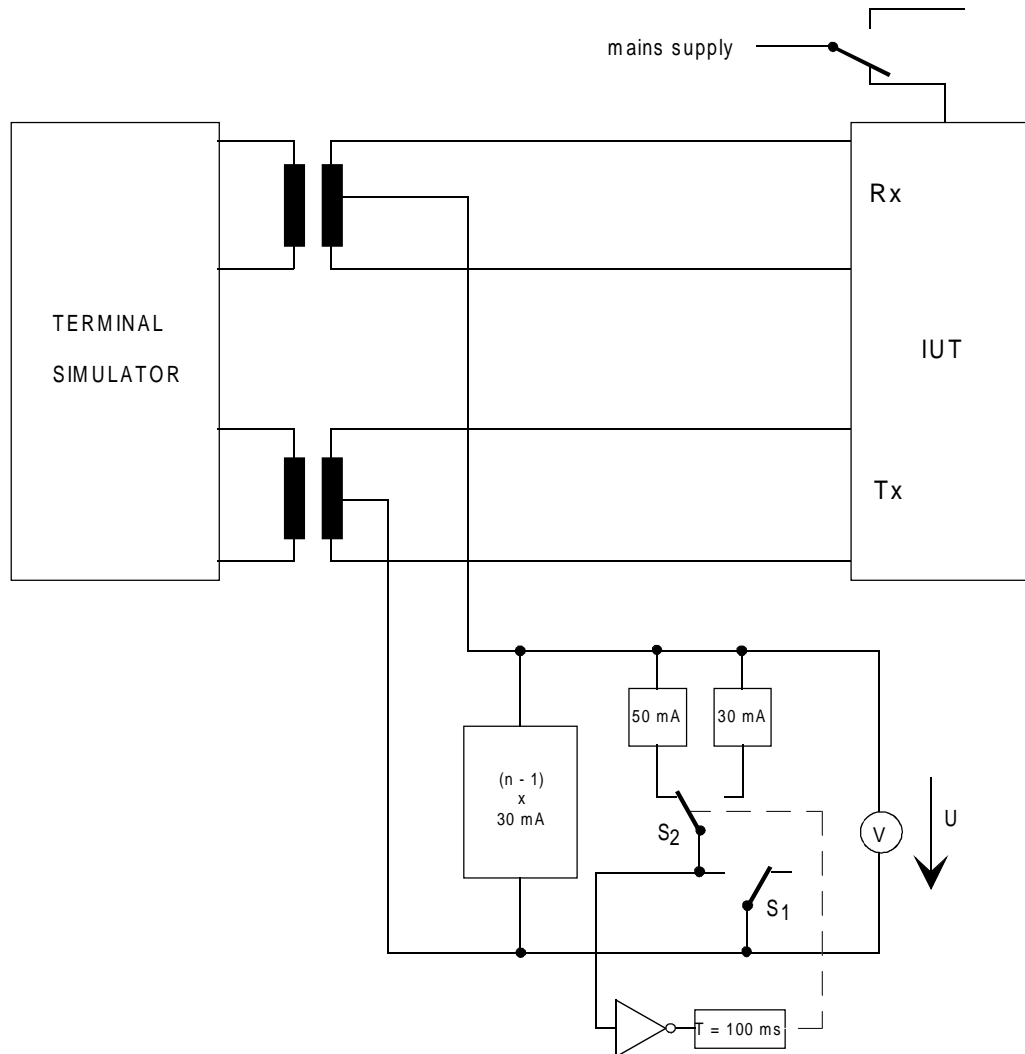

**Figure 34: Test configuration**

**System state:** Any state.

**Stimulus:** Switch on S1 and then after a delay of 100 ms switch on S2.

**Monitor:** Output voltage versus time.

**Results:** The output voltage shall not drop below the minimum voltage of 34 V during the test.

8.1.8 dc unbalance of power source 1

Reference: ETS 300 012-1 [8], subclause 10.7.1.1.

Purpose: To test the dc unbalance of power source 1.

NOTE: This requirement also applies to the APS.

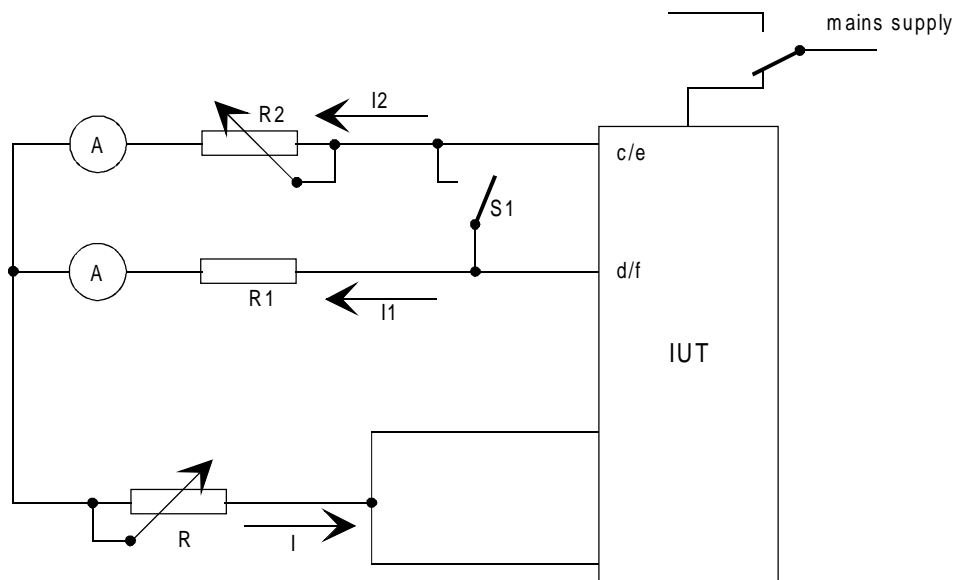

R: Adjust R for drawing max. power provided by PS 1.  
 R1 = 2 Ω

NOTE: Switch S1 is only used for calibration as follows: switch on, adjust R<sub>2</sub> so that the same current is flowing in both wires, then switch off.

Figure 35: Test configuration

System state:	Any state.
Stimulus:	Drawing the maximum power provided by PS1 as declared by the apparatus supplier.
Monitor:	Supply current in each wire.
Results:	The direct current unbalance X shall be less than 3 % of the current i (i = i <sub>1</sub> + i <sub>2</sub> ), flowing through both phantom pairs.

$$X = \frac{|i_1 - i_2|}{i_1 + i_2} \times 100 \%$$

### 8.1.9 Current unbalance in a pair

**Reference:** ETS 300 012-1 [8], subclause 10.7.2.

**Purpose:** To check the influence of current unbalance to receiver and transmitter impedance.

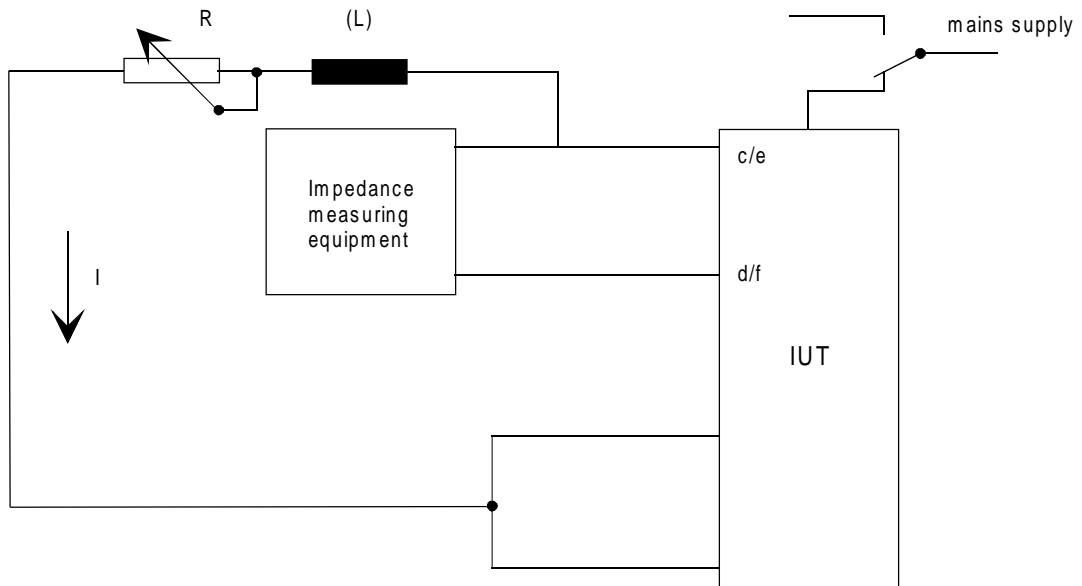

**Figure 36: Test configuration**

**System state:** Deactivated (state G1).

**Stimulus:** Sinusoidal voltage of 100 mV rms, in the frequency range 2 kHz to 20 kHz. In addition, a direct current  $I$  of 3 % of the maximum current provided by the IUT is drawn, which should be adjusted by resistor  $R$ .

**NOTE:** It is not necessary to draw the maximum load current, since only the current difference of two wires of one pair can affect the impedance. The resistor  $R$  is high resistant, its influence can be neglected (it is connected in parallel to the half of the coil of input or output transformer). In addition, a choke ( $L$ ) can be connected in series to  $R$ .

**Monitor:** Input/output impedance over frequency.

**Results:** The impedance of transmitter and receiver shall exceed the impedance indicated by template figure 11 in ETS 300 012-1 [8].

## 8.2 Minimum voltage of power source 2

Reference: ETS 300 012-1 [8], subclause 10.2.3.

Purpose: To measure the IUT voltage available at the access point.

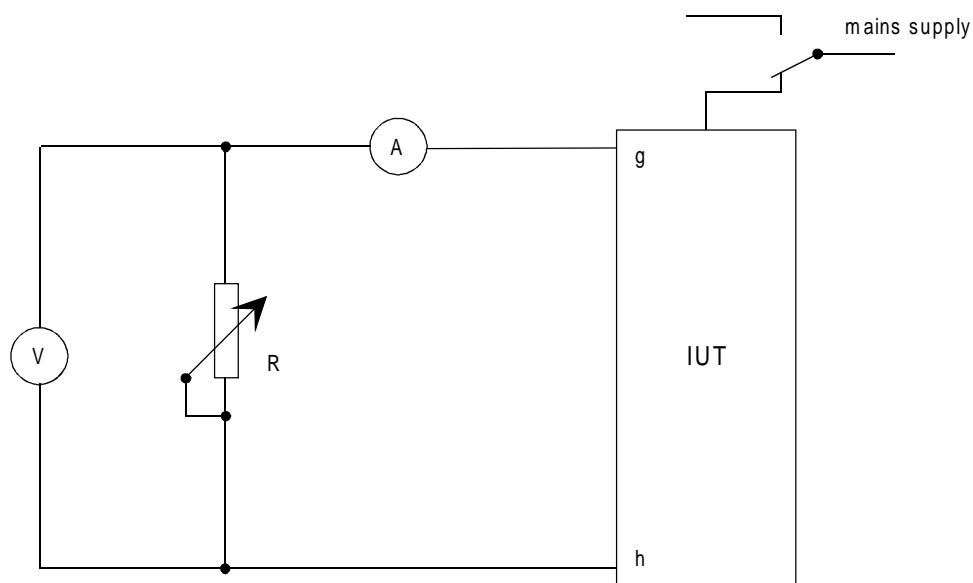

Figure 37: Test configuration

- System state: Any state in normal and restricted modes.
- Stimulus: Drawing no power and up to the maximum power provided by the IUT as declared by the apparatus supplier. Reduce the resistance from  $\infty \Omega$  to a value, so that the maximum power is available according to the power mode.
- Monitor: dc voltage and current.
- Results: The voltage at the output of the source shall be 40 V, +5, -20 %.



## 9 Auxiliary power supply

### 9.1 Additional requirements from an APS

**Reference:** ETS 300 012-1 [8], subclause 10.8.

There are two possible ways of powering a terminal connected to the ISDN passive bus configuration, one of which is phantom powering - deriving power from the differential voltage on the S interface. This method of powering is known in ETS 300 012-1 [8] as power source 1.

Power source 1 has the possibility of being in one of two states, normal powering and restricted powering. It is mandatory for the Network Termination (NT) to provide power source 1 in restricted powering mode. However, normal powering is optional, but can be achieved by using the Auxiliary Power Supply, (APS), i.e. 40 V, +5, -15 % at the APS output.

The APS is physically separate from the NT and can be connected at any point in the interface wiring. If an APS is located inside the same physical equipment as a TE and using the same plug, the power feeding requirements of the TE have to be taken into account. When the TE is a designated one, the APS power consumption when switched off cannot be measured. In this case, the power consumption shall be in accordance with the requirements for designated TEs.

Connection to the S interface wiring is via EN 28877 [5]. The APS shall continuously transmit INFO 0 and thus have impedance template similar to that of Terminal Equipment (TE) transmitting ONEs (see figure 12 in ETS 300 012-1 [8]).

9.1.1 APS switch-on time

Reference: ETS 300 012-1 [8], subclause 10.8.2.

Purpose: To ensure that the APS supplies a stable voltage of + 34 V within 2,5 ms.

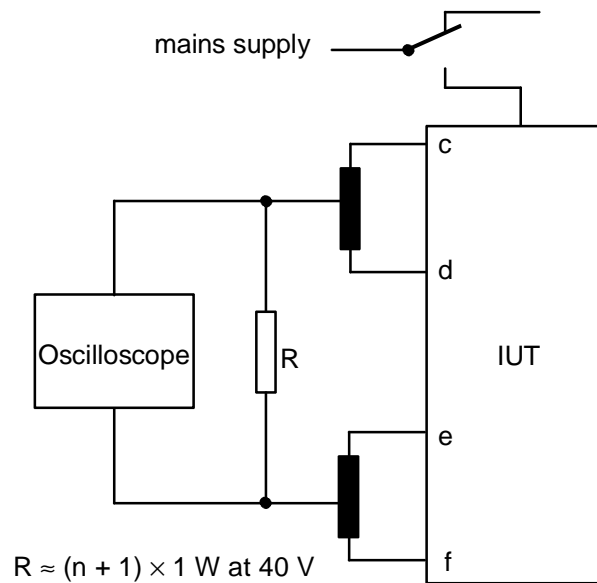

Figure 38: Test configuration

- System state: Any state and a test load R connected across the APS output.
- Stimulus: APS is powered up in all possible sequences (according to the procedures in the supplier's declaration).
- Monitor: Voltage with respect to time across the APS output.
- Results: The access lead pair c-d shall be positive with respect to the access lead pair e-f.  
2,5 ms after the trigger point the voltage shall be  $\geq 34 \text{ V}$ , but  $\leq 42 \text{ V}$  and does not go below 34 V for a further period of at least 2,5 ms.

### 9.1.2 APS switch-off time

Reference: ETS 300 012-1 [8], subclause 10.8.3.

Purpose: To ensure that the time taken for the normal output voltage from the APS to fall from + 34 V to + 1 V is within 2,5 ms.

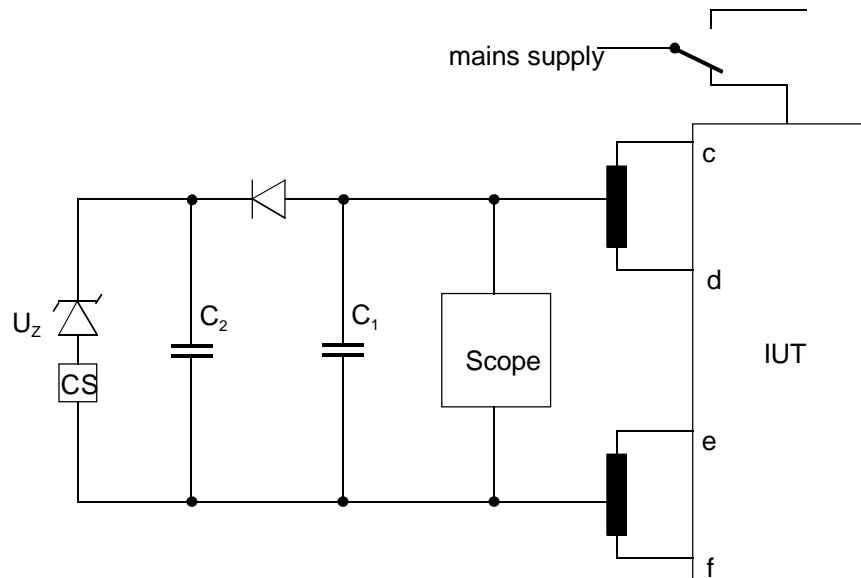

CS = 15 mA,  $U_z = 15$  V,  $C_1 = 100$  nF,  $C_2 = 100$   $\mu$ F

Figure 39: Test configuration

- System state: Any state and a test load connected to the transmit and receive pairs.
- Stimulus: The input power to the APS is removed in all possible sequences (according to the procedures in the supplier's declaration).
- Monitor: Voltage with respect to time across the APS output.
- Results: 2,5 ms after the trigger point the voltage shall be  $\leq 1$  V and does not rise above 1 V for a further period of at least 2,5 ms.

### 9.1.3 APS requirements for type "a" sources

Reference: ETS 300 012-1 [8], subclause 10.6.5.3.

Purpose: To test requirements for voltage increase of an APS with fall-back characteristics, after removal of a short circuit.

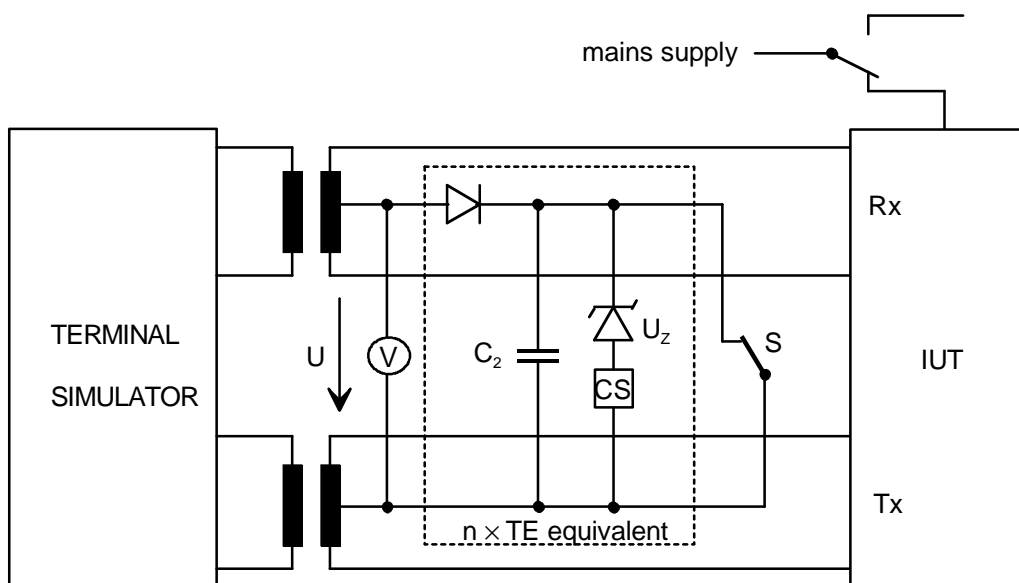

NOTE: CS = 15 mA,  $U_z = 24\text{ V}$ ,  $C_2 = 100\ \mu\text{F}$

**Figure 40: Test configuration**

- System state: Any state.
- Stimulus: Lowest acceptable voltage level at mains interface, short circuit steady state of 30 minutes, removal of short circuit (switch off S), with a load of  $n + 1$  TE-equivalents as given in figure 23 in ETS 300 012-1 [8].
- Monitor: Output voltage under  $(n + 1)$ -times TE-equivalents.
- Results: The output voltage shall increase from 1,0 V to 34 V within 350 ms. This shall occur within 10 seconds after the removal of the short circuit.

9.1.4 APS switch-on surge capability

Reference: ETS 300 012-1 [8], subclause 10.6.5.4.1.

Purpose: Switch-on surge capability, APS in normal mode.

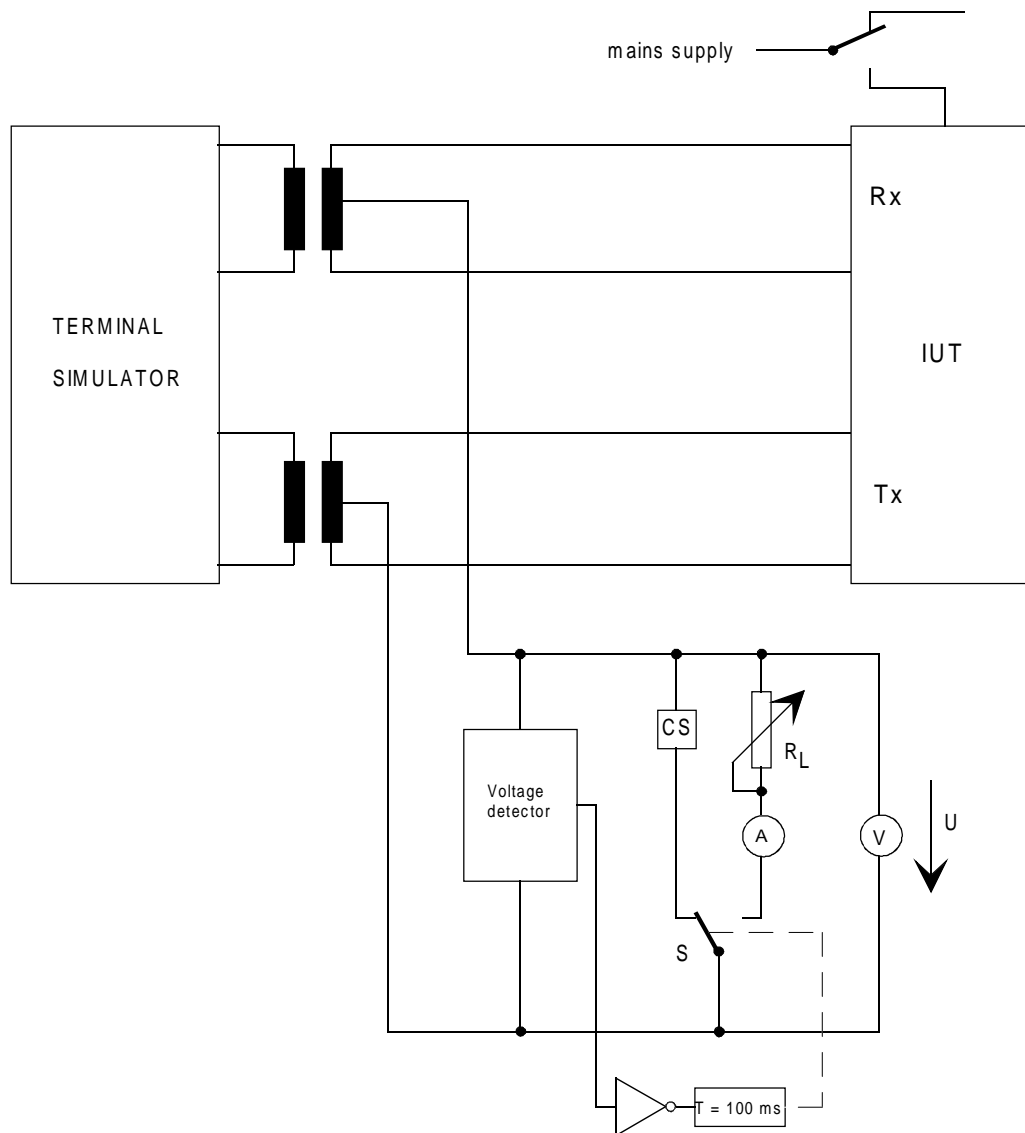

Figure 41: Test configuration

System state: Any state.

Stimulus: Connection of mains supply.

Monitor: Output voltage versus time.

Result: The power source 1 shall provide a minimum of  $(n + 1) \times 45 \text{ mA}$  for at least 100 ms and the voltage shall be at least 30 V during this time period. After the time of 100 ms, the power source shall be able to provide the power of  $(n + 1) \times 1 \text{ Watt}$  and the drop of power on the interface with the output voltage shall be within the specified limits.

9.1.5 APS TE connection surge capability

Reference: ETS 300 012-1 [8], subclause 10.6.5.4.2.

Purpose: TE connection surge capability in normal mode.

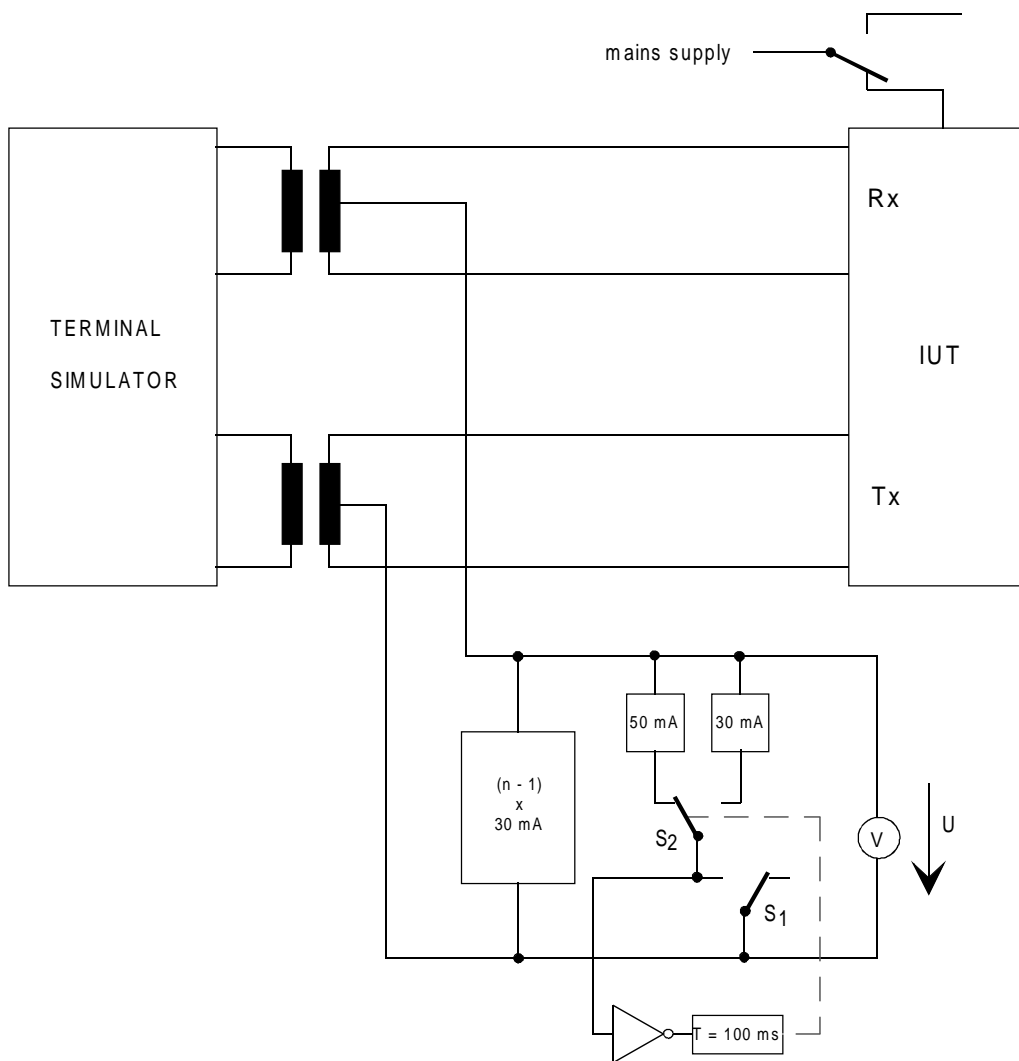

Figure 42: Test configuration

System state: Any state.

Stimulus: Switch on S1 and then after a delay of 100 ms switch on S2.

Monitor: Output voltage versus time.

Results: The output voltage shall not drop below the minimum value of 34 V during this test.

### 9.1.6 APS current unbalance in a pair

**Reference:** ETS 300 012-1 [8], subclause 10.7.2.

**Purpose:** To check influence of current unbalance to receiver and transmitter impedance.

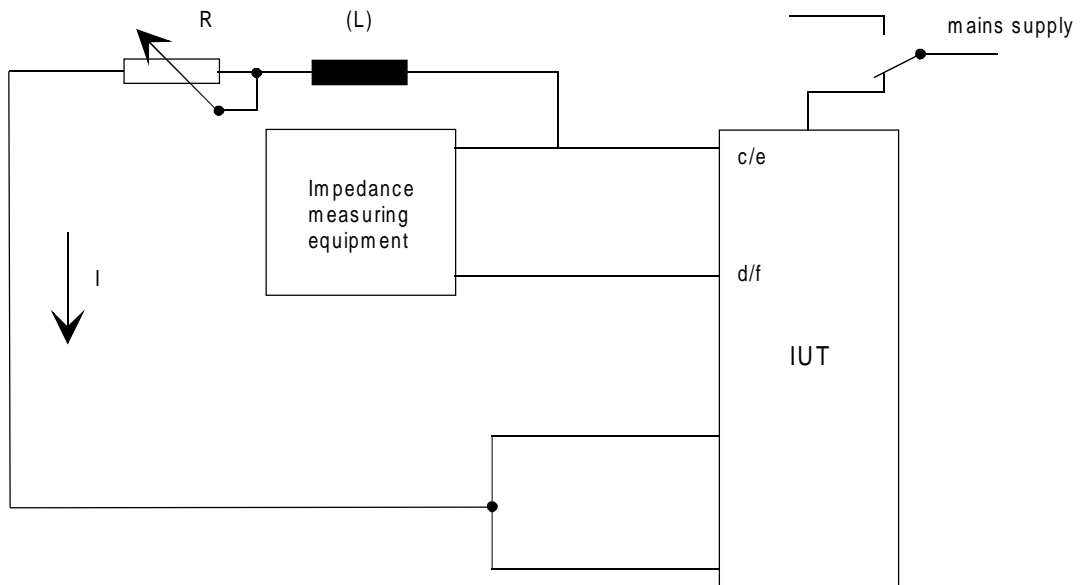

**Figure 43: Test configuration**

**System state:** Deactivated (state G1).

**Stimulus:** Sinusoidal voltage of 100 mV rms, in the frequency range 2 kHz to 20 kHz. In addition, a direct current I of 3 % of the maximum current provided by the IUT is drawn, which should be adjusted using resistor R.

**NOTE:** It is not necessary to draw the maximum load current, since only the current difference of two wires of one pair can affect the impedance. The resistor R is high resistant, its influence can be neglected (it is connected in parallel to the half of the coil of input or output transformer). In addition, a choke (L) can be connected in series to R.

**Monitor:** Input/output impedance over frequency.

**Results:** The impedance of transmitter and receiver shall exceed the impedance indicated by template figure 11 in ETS 300 012-1 [8].

9.2 Additional requirements for NT compatible with APS

Reference: ETS 300 012-1 [8], subclause 10.9.

9.2.1 Power source 1 mode back-off

Reference: ETS 300 012-1 [8], subclause 10.9.1.

Purpose: To ensure that the NT can switch-off the restricted mode power source on detection of PS 1 normal mode on the passive bus.

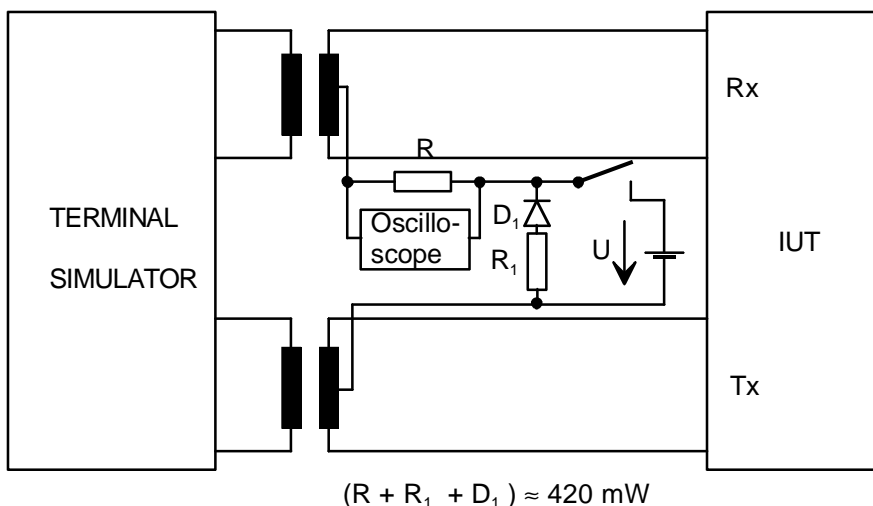

Figure 44: Test configuration

System state: Any state.

Stimulus: NT supplying PS 1 restricted mode to the passive bus.

Phantom supply voltage.  
 $U = 40 \text{ V}$   
 $R = 15 \Omega$ .

Monitor: Voltage with respect to time across the NT output.

Results: The current or power drawn by the PS 1 restricted shall be:

no limitation	for	$0 \text{ s} \leq t \leq 5 \mu\text{s}$ ;
$\leq 45 \text{ mA}$	for	$5 \mu\text{s} < t \leq 100 \text{ ms}$ ;
$\leq 3 \text{ mW}$	for	$t > 100 \text{ ms}$ .



### 9.2.2 Power source 1 restricted mode power-up

**Reference:** ETS 300 012-1 [8], subclause 10.9.2.

**Purpose:** To ensure that the NT can switch to restricted mode power source on detection of a normal mode voltage between 2 V and 5 V (loss of PS 1 normal mode).

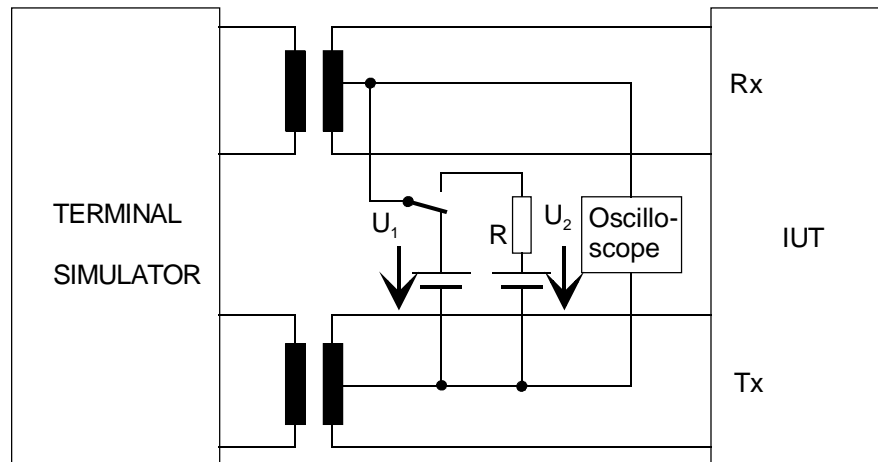

$$U_1 = 24 \text{ V}, R = 3,8 \text{ k}\Omega \approx 420 \text{ mW at } 40 \text{ V}$$

**Figure 45: Test configuration**

**System state:** Any state.

**Stimulus:** Switch over from  $U_1$  to  $U_2$ .

- a)  $U_2 = 5 \text{ V}$
- b)  $U_2 = 2 \text{ V}$

**Monitor:** The phantom voltage of the NT.

- Results:**
- a) the voltage shall be equal to 5 V;
  - b) the NT shall drive the phantom voltage to rise - 34 V (but not exceeding - 42 V) within 2,5 ms after the switch-over from  $U_1$  to  $U_2$ . For a further 2,5 ms the phantom voltage shall be in the range from - 34 V to 42 V.

### 9.2.3 Power consumption from APS normal mode

Reference: ETS 300 012-1 [8], subclause 10.9.3.

Purpose: To ensure that the NT does not consume more than 3 mW from the passive bus when the APS is supplying PS 1 normal mode.

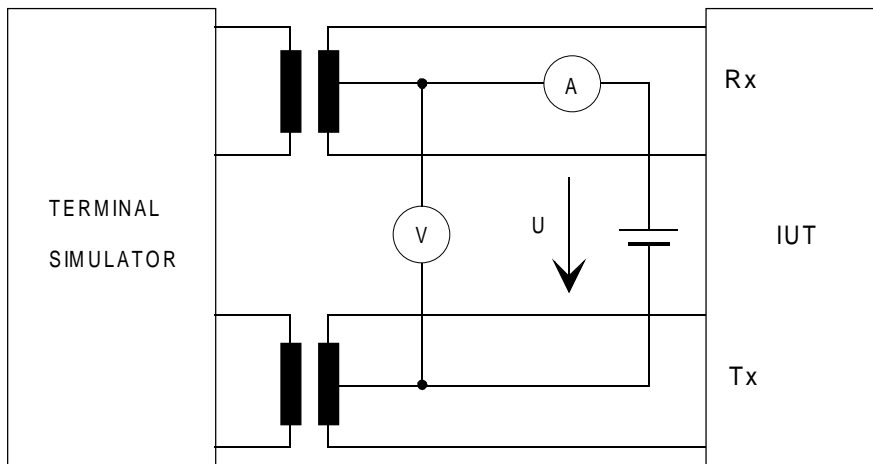

Figure 46: Test configuration

System state: Any state.

Stimulus: Phantom normal mode Power Source 1 in the voltage range  
40 V, +5 %, -40 % (i.e. 42 V to 24 V).

Monitor: dc voltage and current in the access leads.

Results: The power consumed by the NT shall not exceed 3 mW at both extremes of the power source voltage as stated in the stimulus section. This does not apply for the first 100 ms after the connection of the power source.

## Annex A (normative): Connection cords and general testing requirements

### A.1 Connection cords

In the case where a PTNX does not use a connection cord at the T reference point, the location of interface I<sub>B</sub> shall be declared by the PTNX supplier.

However, equipment using detachable connecting cords and designated for connection with a "standard ISDN basic access cord" shall meet the specified electrical characteristics in both cases as follows:

- a) with a specific cord provided with the IUT;
- b) with a reference cord conforming to the requirements as described in table A.1:

**Table A.1: Electrical characteristics of the ISDN reference cord**

Parameter	C	Z	CL	R	D
Value	100 pF	> 75 Ω	> 60 dB	1 Ω	< 0,5 %
Tolerance	+0 % -10 %	-	-	+0 % -10 %	-
C: capacitance of pairs for transmit and receive functions; Z: characteristic impedance of pairs used for transmit and receive functions at 96 kHz; CL: crosstalk loss at 96 kHz between any pair and a pair used for transmit and receive functions with terminations at 100 Ω; R: resistance of an individual conductor; D: difference of the ohmic resistance in each pair (percentage of the ohmic resistance).  NOTE: The total length of the cord depends on the parameters shown above. Nevertheless, this length should be 3m.					

### A.2 General testing requirements

The test configurations given do not imply a specific realization of test equipment or arrangement or the use of specific test devices for conformance testing. However, any test configuration used shall provide those test conditions specified under "system state", "stimulus" and "monitor" for each individual test (the measurement arrangements and the equipment suggested are only for example purposes).

Normally, an equipment providing an interface I<sub>B</sub> of the basic rate access cannot be tested by applying a stimulus only at this interface (see figures below). For some tests, a signal providing the timing clock shall be applied to the "master" interface of such an equipment. If necessary, this signal shall contain the INFOs used to bring the IUT in the defined system states. Examples for a "master" interface where the IUT is synchronized are:

- any U interface in case of a NT1;
- a basic or primary rate access in case of a NT2.

Only when a NT2 is not synchronized, it can be tested separately.

A description of the signals applied to the "master" interface or of the action to the user shall of an IUT are outside the scope of these test principles.

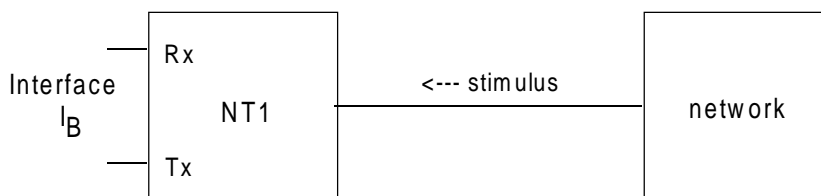

**Figure A.1: NT1 is synchronized to a network**

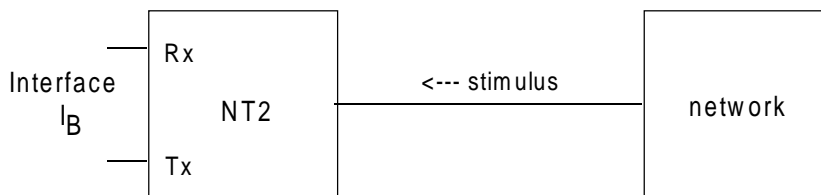

**Figure A.2: NT2 is synchronized to a network**

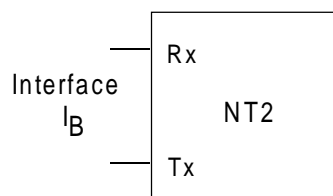

**Figure A.3: NT2 is synchronized to a network (free running mode)**

For conformance test purposes it is required that a transparent loopback of B1- and B2-channel is provided.

For conformance test purposes it is required that the terminating resistors (100 Ω) shall be removed from the NT receiving and transmitting pairs (it is sufficient to remove the terminating resistors only in the equipment provided for conformance test purposes). In this case the value of the resistors shall be checked (100 Ω ± 5 %) and the NT with its installed terminating resistors shall also conform to this ETS.

IUT suppliers shall provide information on how IUT primitive exchanges can be detected i. e. primitives activate, deactivate, management primitives between layer 1 and higher layers.

Unless otherwise stated the line termination resistors for both NT and TE side are considered inside the test equipment.

## History

Document history	
April 1992	First Edition
November 1996	Public Enquiry PE 118: 1996-11-18 to 1997-03-14