



EUROPEAN
TELECOMMUNICATION
STANDARD

DRAFT
pr **ETS 300 012-4**

November 1996

Second Edition

Source: ETSI TC-TM

Reference: RE/TM-03038-4

ICS: 33.040.20

Key words: Basic, ISDN, layer 1, testing, transmission, UNI

**Integrated Services Digital Network (ISDN);
Basic User Network Interface (UNI);
Part 4: Conformance test specification for interface I_A**

ETSI

European Telecommunications Standards Institute

ETSI Secretariat

Postal address: F-06921 Sophia Antipolis CEDEX - FRANCE

Office address: 650 Route des Lucioles - Sophia Antipolis - Valbonne - FRANCE

X.400: c=fr, a=atlas, p=etsi, s=secretariat - **Internet:** secretariat@etsi.fr

Tel.: +33 4 92 94 42 00 - Fax: +33 4 93 65 47 16

Copyright Notification: No part may be reproduced except as authorized by written permission. The copyright and the foregoing restriction extend to reproduction in all media.

© European Telecommunications Standards Institute 1996. All rights reserved.

Contents

Foreword	7
1 Scope	9
2 Normative references	9
3 Definitions, symbols and abbreviations	10
3.1 Definitions	10
3.2 Symbols	11
3.3 Abbreviations	11
4 Allocation of tests	12
4.1 Scope	12
4.2 Normative references	12
4.3 Definitions, symbols and abbreviations	13
4.4 Primitives associated with layer 1	13
4.5 Wiring configurations and location of interface points	14
4.6 Functional characteristics	14
4.7 Interface procedures	14
4.8 Electrical characteristics	16
4.9 Power feeding	17
4.10 Interface connector contact assignment	18
4.11 Annexes	19
5 Functional characteristic tests	20
5.1 Binary organization of frame	20
5.1.1 Test A	20
5.1.2 Test B	22
6 Interface procedure tests	23
6.1 D-channel access control procedure	23
6.1.1 Interframe (layer 2) time fill	23
6.1.2 D-echo channel response	24
6.2 Activation/deactivation	25
6.2.1 Activation/deactivation procedure	25
6.2.2 Timer for activation/deactivation	27
6.2.2.1 Timer for activation when receiving INFO 2	27
6.2.2.1.1 Test A in state F3	27
6.2.2.1.2 Test B in state F4	28
6.2.2.2 Timer for activation when receiving INFO 4	29
6.2.2.2.1 Test A in state F3	29
6.2.2.2.2 Test A in state F4	30
6.2.2.3 Timer for activation when receiving any signal	31
6.2.2.4 Value of the timer T3	32
6.2.2.5 Timer for physical deactivation	33
6.2.2.5.1 Test A in state F6	33
6.2.2.5.2 Test B in state F7	34
6.2.2.6 Timer for complete deactivation	35
6.2.2.6.1 Test A in state F7	35
6.2.2.6.2 Test B in state F8	36
6.3 Frame alignment procedures	37
6.4 Multi-framing procedures	38
6.5 Idle channel code on the B-channels	39
7 Electrical characteristics tests	40
7.1 Frame rate when transmitting an INFO 1	41
7.2 TE jitter characteristics	42
7.2.1 TE jitter measurement characteristics (test A)	42

	7.2.2	TE output phase deviation (test B)	44
7.3		TE transmitter output impedance	46
	7.3.1	Test A	46
	7.3.2	Test B	47
	7.3.3	Test C	48
	7.3.4	Test D	49
	7.3.5	Test E	50
7.4		Pulse shape and amplitude	51
7.5		Pulse unbalance	52
	7.5.1	Pulse amplitude	52
	7.5.2	Pulse unbalance of an isolated couple of pulses	53
7.6		Voltage on other test loads	54
	7.6.1	Test A	54
	7.6.2	Test B	55
7.7		Longitudinal conversion loss of transmitter output	56
7.8		Receiver input characteristics	57
	7.8.1	TE receiver input impedance	57
		7.8.1.1 Test A	57
		7.8.1.2 Test B	58
		7.8.1.3 Test C	59
		7.8.1.4 Test D	60
	7.8.2	Receiver sensitivity - noise and distortion immunity	61
	7.8.3	Unbalance about earth of receiver input	62
8		Power feeding	63
	8.1	Power source 1 phantom mode	64
		8.1.1 Normal power conditions	64
		8.1.1.1 Normal power provision (Test A)	64
		8.1.1.2 Normal power provision (Test B)	65
		8.1.1.3 Normal power provision (Test C)	66
		8.1.1.4 Normal power provision (Test D)	67
		8.1.1.5 Normal power provision (Test E)	68
	8.1.2	Restricted power conditions	69
		8.1.2.1 Restricted power provision (Test A)	69
		8.1.2.2 Restricted power provision (Test B)	70
		8.1.2.3 Restricted power provision (Test C)	71
		8.1.2.4 Restricted power provision (Test D)	72
		8.1.2.5 Restricted power provision (Test E)	73
		8.1.2.6 Restricted power provision (Test F)	74
	8.1.3	Current transient	75
	8.1.4	Limitation on power sink during transient conditions	76
		8.1.4.1 Current/time limitation for TE	76
		8.1.4.3 Behaviour of a TE using a connection detector	78
		8.1.4.4 Power start-up test	79
		8.1.4.4.1 Power start-up test after removal of short-circuit	79
		8.1.4.4.2 Power start-up test at low input voltage	80
		8.1.4.5 Protection against short-term interruptions	81
		8.1.4.5.1 Normal power	81
		8.1.4.5.2 Restricted power	82
		8.1.4.6 Behaviour at the switch-over	83
		8.1.4.6.1 Normal power	83
		8.1.4.6.2 Restricted power	84
		8.1.4.7 dc unbalance of TEs using power sink 1	85
		8.1.4.8 Effect of current unbalance	86
	8.2	Power source 2 - optional third pair	87
	8.3	Galvanic isolation	88
		Annex A (normative): Connection cords and general testing requirements	89
		A.1 Connection cords	89

A.2 General testing requirements..... 89
History..... 90

Blank page

Foreword

This draft second edition European Telecommunication Standard (ETS) has been produced by the Transmission and Multiplexing (TM) Technical Committee of the European Telecommunications Standards Institute (ETSI), and is now submitted for the Public Enquiry phase of the ETSI standards approval procedure.

This ETS concerns the basic User Network Interface (UNI) for the Integrated Services Digital Network (ISDN) and consists of 7 parts as follows:

- Part 1: "Layer 1 specification";
- Part 2: "Implementation Conformance Statement (ICS) and Implementation Extra Information for Testing (IXIT) for interface I_A";
- Part 3: "Implementation Conformance Statement (ICS) and Implementation Extra Information for Testing (IXIT) for interface I_B";
- Part 4: "Conformance test specification for interface I_A";**
- Part 5: "Conformance test specification for interface I_B";
- Part 6: "Abstract Test Suite (ATS) specification for interface I_A";
- Part 7: "Abstract Test Suite (ATS) specification for interface I_B".

and is based on ITU-T Recommendation I.430 [1].

Proposed transposition dates	
Date of latest announcement of this ETS (doa):	3 months after ETSI publication
Date of latest publication of new National Standard or endorsement of this ETS (dop/e):	6 months after doa
Date of withdrawal of any conflicting National Standard (dow):	6 months after doa

Blank page

1 Scope

This part 4 of ETS 300 012 provides the test principles for the requirements of this ETS used to determine the compliance of an Implementation Under Test (IUT) to this ETS.

It is outside the scope of this ETS to identify the specific tests required by an implementation where equipment has to meet attachment approval.

Detailed test equipment accuracy and the specification tolerance of the test devices is not a subject of this ETS. Where such details are provided then those test details are to be considered as being an "informative" addition to the test description.

Unless otherwise stated, conformance tests described in this ETS do not apply to the Auxiliary Power Supply (APS).

This ETS is applicable to interface I_A. The field of applicability is reported at the beginning of each test.

Ideal values for components and circuits are considered in the test principles.

Details concerning connection cords and general testing requirements can be found in annex A of this part 4 of ETS 300 012.

2 Normative references

This ETS incorporates by dated and undated reference, provisions from other publications. These normative references are cited at the appropriate places in the text and the publications are listed hereafter. For dated references, subsequent amendments to or revisions of any of these publications apply to this ETS only when incorporated in it by amendment or revision. For undated references the latest edition of the publication referred to applies.

- [1] ITU-T Recommendation I.430 (1995): "Basic user-network interface - layer 1 specification".
- [2] ITU-T Recommendation I.411 (1993): "ISDN user-network interfaces - Reference configurations".
- [3] ETS 300 047-3 (1992): "Integrated Services Digital Network (ISDN); Basic access - safety and protection; Part 3: Interface I_A - protection".
- [4] EN 60603-7 (1993): "Connectors for frequencies below 3 MHz for use with printed boards - Part 7: Detail specification for connectors, 8-way, including fixed and free connectors with common mating features; (IEC 603-7:1990)".
- [6] CCITT Recommendation G.117 (1988): "Transmission aspects of unbalance about earth (definitions and methods)".
- [7] ETS 300 102-1 (1990): "Integrated Services Digital Network (ISDN); User-network interface layer 3; Specifications for basic call control".
- [8] ETS 300 012-1 (1996): "Integrated Services Digital Network (ISDN); Basic User Network Interface (UNI); Part 1: Layer 1 specification".
- [9] ITU-T Recommendation X.200 (1994): "Information technology; Open Systems Interconnection; Basic reference model: The basic model".

3 Definitions, symbols and abbreviations

3.1 Definitions

For the purposes of this ETS the following definitions, together with those given in annex E of ITU-T Recommendation I.430 [1] and in ITU-T Recommendation I.411 [2] apply.

basic access: A user-network access arrangement that corresponds to the interface structure composed of two B-channels and one D-channel. The bit rate of the D-channel for this type of access is 16 kbit/s.

B-channel: This function provides for the bidirectional transmission of independent B-channel signals each having a bit rate of 64 kbit/s.

bearer service: A type of telecommunication service that provides the capability for the transmission of signals between user-network interfaces.

NOTE 1: The ISDN connection type used to support a bearer service may be identical to that used to support other types of telecommunication service.

connection management entity: An entity for the purpose of management of resources that have an impact on an individual data link connection.

D-channel: This function provides for bidirectional transmission of one D-channel signal at a bit rate of 16 kbit/s.

designated terminal: A terminal which is permitted to draw power from power source 1 under both normal and restricted power conditions.

frame alignment: This function provides information to enable the TE or NT to recover the time-division multiplexed channels.

Integrated Services Digital Network (ISDN): A network that provides or supports a range of different telecommunications services and provides digital connections between user-network interfaces.

interface I_A: User side of the ISDN user-network interface for the basic access.

interface I_B: Network side of the ISDN user-network interface for the basic access.

Network Termination (NT): An equipment providing interface I_B.

NOTE 2: This term is used in this ETS to indicate network-terminating aspects of NT1, NT2 and PS1 functional groups where these have an I_B interface.

Network Termination type 1 (NT1): This functional group includes functions broadly equivalent to layer 1 (physical) of the Open Systems Interconnection (OSI) reference model. These functions are associated with the proper physical and electromagnetic termination of the network. NT1 functions are:

- line transmission termination;
- layer 1 maintenance functions and performance monitoring;
- timing;
- power transfer;
- layer 1 multiplexing;
- interface termination, including multidrop termination;
- employing layer 1 contention resolution.

Network Termination type 2 (NT2): This functional group includes functions broadly equivalent to layer 1 and higher layers of the ITU-T Recommendation X.200 [9] reference model. Private Automatic Branch Exchanges (PABXs), Local Area Networks (LANs), and terminal controllers are examples of equipment or combinations of equipment that provide NT2 functions. NT2 functions include:

- layer 2 and 3 protocol handling;
- layer 2 and 3 multiplexing;
- switching;
- concentration;
- maintenance functions;
- interface termination and other layer 1 functions.

non-designated terminal: A terminal which is only permitted to draw power from power source 1 under normal power conditions.

normal power condition: The condition indicated by the normal polarity of the phantom voltage at the access leads, i.e. where the voltage of the transmit leads c and d on the TE is positive with respect to the voltage on the receive leads e and f.

Power Source 1 (PS1): Power source for the provision of remote power feeding of TE via a phantom circuit of the interface wires.

restricted power condition: The condition indicated by the reversed polarity of the phantom voltage at the access leads, i.e. where the voltage of the receive leads e and f on the TE is positive with respect to the voltage on the transmit leads c and d.

simulator: Device generating the stimulus signal for the IUT and monitoring the signal transmitted by the IUT to find the result.

Terminal Adapter (TA): An equipment with interface IA and one or more auxiliary interfaces that allow non-ISDN terminals to be served by an ISDN user-network interface (see also ITU-T Recommendation I.411 [2]).

Terminal Equipment (TE): An equipment with interface IA and consisting of one or more functional blocks.

NOTE 3: This term is used in this TBR to indicate terminal-terminating aspects of TE1, TA and NT2 functional groups, where these have an I_A interface.

Terminal Equipment Type 1 (TE1): This functional group includes functions belonging to the functional group TE, and with an interface that complies with the ISDN user-network interface recommendation.

3.2 Symbols

For the purposes of this ETS, the following symbols apply:

ONE	Binary "1"
ZERO	Binary "0"

3.3 Abbreviations

For the purposes of this ETS, the following abbreviations apply:

APS	Auxiliary Power Supply
dc	direct current
ETS	European Telecommunication Standard
HDLC	High level Data Link Control
I	Informative
I _A	Interface point A
I _B	Interface point B
ICS	Implementation Conformance Statement
ISDN	Integrated Services Digital Network

IUT	Implementation Under Test
IXIT	Implementation eXtra Information for Testing
LCL	Longitudinal Conversion Loss
N	Normative
N/R	Not Relevant
NT	Network Termination
ppm	parts per million
PS1	Power Source 1
PS2	Power Source 2
PTNX	Private Telecommunication Network Exchange
Rx	Receive
Tx	Transmit
UI	Unit Interval (Layer 1)

4 Allocation of tests

4.1 Scope

Scope	Clause / subclause in ETS 300 012-1 [8]	Test defined in clause / subclause of this ETS
Scope	1	N/R

4.2 Normative references

Normative references	Clause / subclause in ETS 300 012-1 [8]	Test defined in clause / subclause of this ETS
Normative references	2	N/R

4.3 Definitions, symbols and abbreviations

Definitions, symbols and abbreviations	Clause / subclause in ETS 300 012-1 [8]	Test defined in clause / subclause of this ETS
Definitions, symbols and abbreviations	3	N/R
Definitions	3.1	N/R
General definitions	3.1.1	N/R
Interface	3.1.1.1	N/R
NT	3.1.1.2	N/R
TE	3.1.1.3	N/R
Definition of services	3.1.2	N/R
Services required from the physical medium	3.1.2.1	N/R
Services provided to layer 2	3.1.2.2	N/R
Transmission capability	3.1.2.2.1	N/R
Activation/deactivation	3.1.2.2.2	N/R
D-channel access	3.1.2.2.3	N/R
Maintenance	3.1.2.2.4	N/R
Status indication	3.1.2.2.5	N/R
Primitives between layer 1 and other entities	3.1.3	N/R
Modes of operation	3.1.4	N/R
Point-to-point operation	3.1.4.1	N/R
Point-to-multipoint operation	3.1.4.2	N/R
Definitions of states	3.1.5	N/R
TE states	3.1.5.1	N/R
State F1 (inactive)	3.1.5.1.1	6.2.1
State F2 (sensing)	3.1.5.1.2	6.2.1
State F3 (deactivated)	3.1.5.1.3	6.2.1
State F4 (awaiting signal)	3.1.5.1.4	6.2.1
State F5 (identifying input)	3.1.5.1.5	6.2.1
State F6 (synchronized)	3.1.5.1.6	6.2.1
State F7 (activated)	3.1.5.1.7	6.2.1
State F8 (lost framing)	3.1.5.1.8	6.2.1
NT states	3.1.5.2	N/R
State G1 (deactive)	3.1.5.2.1	N/R
State G2 (pending activation)	3.1.5.2.2	N/R
State G3 (active)	3.1.5.2.3	N/R
State G4 (pending deactivation)	3.1.5.2.4	N/R
Symbols	3.2	N/R
Abbreviations	3.3	N/R

4.4 Primitives associated with layer 1

Primitives associated with layer 1	Clause / subclause in ETS 300 012-1 [8]	Test defined in clause / subclause of this ETS
Primitives associated with layer 1	4	N/R

4.5 Wiring configurations and location of interface points

Modes	Clause / subclause in ETS 300 012-1 [8]	Test defined in clause / subclause of this ETS
Wiring configurations and location of interface points	5	N/R
General	5.1	N/R
Point-to-point configuration	5.1.1	N/R
Point-to-multipoint configuration	5.1.2	N/R
Location of the interfaces	5.1.3	N/R
Support of wiring configurations	5.2	N/R
Wiring polarity integrity	5.2.1	6.2.2.1.1
NT and TE associated wiring	5.2.2	N/R

4.6 Functional characteristics

Functions	Clause / subclause in ETS 300 012-1 [8]	Test defined in clause / subclause of this ETS
Functional characteristics	6	N/R
Interface functions	6.1	N/R
B-channel	6.1.1	5.1.1
Bit timing	6.1.2	5.1.1
Octet timing	6.1.3	5.1.1
Frame alignment	6.1.4	6.3
D-channel	6.1.5	6.1.2
D-channel access procedure	6.1.6	6.1.2
Power feeding	6.1.7	8
Deactivation	6.1.8	6.3.2
Activation	6.1.9	6.3.2
Interchange circuits	6.2	5.1.1
Connected/disconnected indication	6.3	6.2
TEs powered across the interface	6.3.1	6.2
TEs not powered across the interface	6.3.2	6.2
Indication of connection status	6.3.3	6.2
Line code	6.4	5.1.1
Frame structure	6.5	5.1.1
Bit rate	6.5.1	5.1.1
Binary organization of the frame	6.5.2	N/R
TE to NT	6.5.2.1	5.1.1
NT to TE	6.5.2.2	N/R
Timing considerations	6.6	5.1.1

4.7 Interface procedures

D-channel access	Clause / subclause in ETS 300 012-1 [8]	Test defined in clause / subclause of this ETS
Interface procedures	7	N/R
D-channel access procedure	7.1	N/R
Interframe (layer 2) time fill	7.1.1	6.1.1
D-echo channel	7.1.2	N/R
D-channel monitoring	7.1.3	6.1.2
Priority mechanism	7.1.4	6.1.2
Collision detection	7.1.5	6.1.2

Activation/deactivation	Clause / subclause in ETS 300 012-1 [8]	Test defined in clause / subclause of this ETS
Activation/deactivation	7.2	N/R
Activate primitives	7.2.1	6.2
Deactivate primitives	7.2.2	6.2
Management primitives	7.2.3	6.2
Valid primitive sequences	7.2.4	N/R
Signals	7.3	5.1.1, 5.1.2
Activation/deactivation procedure for TEs	7.4	N/R
General TE procedures	7.4.1	6.1
Specification of the procedures	7.4.2	6.2.1, 6.2.2.6
Activation/deactivation for NTs	7.5	N/R
Non-activating/non-deactivating NTs	7.5.1	N/R
Timer values	7.6	6.2.2.4
Activation times	7.7	N/R
TE activation times	7.7.1	6.2.2.1.1, 6.2.2.1.2, 6.2.2.2.1, 6.2.2.2.2, 6.2.2.3
NT activation times	7.7.2	N/R
Deactivation times	7.8	6.2.2.5

Frame alignment	Clause / subclause in ETS 300 012-1 [8]	Test defined in clause / subclause of this ETS
Frame alignment procedures	8	N/R
Frame alignment procedure in the direction NT to TE	8.1	N/R
Loss of frame alignment	8.1.1	6.3
Frame alignment	8.1.2	6.3
Frame alignment in the direction TE to NT	8.2	N/R
Loss of frame alignment	8.2.1	N/R
Frame alignment	8.2.2	N/R
Multi-framing	8.3	6.4
Idle channel code on the B-channels	8.4	6.5

4.8 Electrical characteristics

Functions	Clause / subclause in ETS 300 012-1 [8]	Test defined in clause / subclause of this ETS
Electrical characteristics	9	N/R
Bit rate	9.1	N/R
Nominal rate	9.1.1	7.1
Tolerance	9.1.2	7.1
Jitter and bit-phase relationship between TE input and output	9.2	N/R
Test configurations	9.2.1	7.2.1, 7.8.2
Timing extraction jitter	9.2.2	7.2.1
Total phase deviation input to output	9.2.3	7.2.2
NT jitter characteristics	9.3	N/R
Termination of the line	9.4	N/R
Transmitter output characteristics	9.5	N/R
Transmitter output impedance	9.5.1	N/R
NT transmitter output impedance	9.5.1.1	N/R
TE transmitter output impedance	9.5.1.2	7.3
Test load impedance	9.5.2	N/R
Pulse shape and amplitude (binary ZERO)	9.5.3	7.4
Pulse shape	9.5.3.1	7.4
Nominal pulse amplitude	9.5.3.2	7.4
Pulse unbalance	9.5.4	N/R
Pulse amplitude when transmitting a high density pattern	9.5.4.1	7.5.1
Pulse unbalance of an isolated couple of pulses	9.5.4.2	7.5.2
Voltage on other test loads (TE only)	9.5.5	7.6
400 Ω load	9.5.5.1	7.6.1
5,6 Ω load	9.5.5.2	7.6.2
Unbalance about earth	9.5.6	7.7
Longitudinal conversion loss	9.5.6.1	7.7
Output signal balance	9.5.6.2	N/R
Receiver input characteristics	9.6	N/R
Receiver input impedance	9.6.1	N/R
TE receiver input impedance	9.6.1.1	7.8.1
NT receiver input impedance	9.6.1.2	N/R
Receiver sensitivity - Noise and distortion immunity	9.6.2	7.8.2
TEs	9.6.2.1	7.8.2
NTs for short passive bus (fixed timing)	9.6.2.2	N/R
NTs for both point-to-point and short passive bus configurations (adaptive timing)	9.6.2.3	N/R
NTs for extended passive bus wiring configurations	9.6.2.4	N/R
NTs for point-to-point configurations only	9.6.2.5	N/R
NT receiver input delay characteristics	9.6.3	N/R
NT for short passive bus	9.6.3.1	N/R
NT for both point-to-point and passive bus	9.6.3.2	N/R
NT for extended passive bus	9.6.3.3	N/R
NT for point-to-point only	9.6.3.4	N/R
Unbalance about earth	9.6.4	7.8.3
Isolation from external voltages	9.7	N/R
Interconnecting media characteristics	9.8	N/R
Standard ISDN basis access TE cord	9.9	A.1

4.9 Power feeding

Static requirements	Clause / subclause in ETS 300 012-1 [8]	Test defined in clause / subclause of this ETS
Power feeding	10	N/R
Reference configuration	10.1	N/R
Functions specified at the access leads	10.1.1	5.1.1, 8.1.1.1
Provision of power sources and sinks	10.1.2	N/R
Power available from NT	10.2	N/R
Power source 1 normal and restricted mode	10.2.1	N/R
Minimum voltage at NT from power source 1	10.2.2	N/R
Normal power conditions	10.2.2.1	N/R
Restricted power conditions	10.2.2.2	N/R
Minimum voltage of power source 2	10.2.3	N/R
Power available at a TE	10.3	N/R
Power source 1 - phantom mode	10.3.1	N/R
Normal power 1 - phantom mode	10.3.1.1	8.1.1, 8.1.4.4.2
Restricted power conditions	10.3.1.2	8.1.2
Power source 2 - optional third pair	10.3.2	N/R
Normal power conditions	10.3.2.1	8.2
Restricted power conditions	10.3.2.2	8.2
Power source 1 consumption	10.4	N/R
Normal power conditions	10.4.1	8.1.1.1, 8.1.1.2, 8.1.1.3, 8.1.1.4, 8.1.1.5
Restricted power conditions	10.4.2	8.1.2
Power available to a TE "designated" for restricted power operation	10.4.2.1	8.1.2, 8.1.2.3
Power available to "non-designated" TEs	10.4.2.2	8.1.2.4, 8.1.2.5, 8.1.2.6
Galvanic isolation	10.5	8.3

Dynamic requirements	Clause / subclause in ETS 300 012-1 [8]	Test defined in clause / subclause of this ETS
Current transient	10.6	8.1.4
Current/time limitations for TEs	10.6.1	8.1.4.1, 8.1.4.2, 8.1.4.3
TE design to minimize power disturbance	10.6.2	8.1.4.1, 8.1.4.2, 8.1.4.3
Optimized current/time mask	10.5.2.1	8.1.4.1, 8.1.4.2, 8.1.4.3
Alternative current/time mask for optimized TEs	10.6.2.2	8.1.4.1, 8.1.4.2, 8.1.4.3
Power source switch-over	10.6.3	N/R
Power source switch-over time	10.6.3.1	N/R
Restricted mode power source requirements under overload conditions	10.5.3.2	N/R
Other TE requirements	10.6.4	N/R
Minimum TE start-up current	10.6.4.1	8.1.4.4.1
Protection against short term interruptions	10.6.4.2	8.1.4.5
Behaviour at switch-over	10.6.4.3	8.1.4.6
Other power source requirements	10.6.5	N/R
Power source 1 restricted	10.6.5.1	N/R
Power source 1 normal	10.6.5.2	N/R
Requirements for type (a) source	10.6.5.3	N/R
Requirements for both types of sources	10.6.5.4	N/R
Switch-on surge capability	10.6.5.4.1	N/R
TE connection surge capability	10.6.5.4.2	N/R
Current unbalance	10.7	N/R
Direct current unbalance	10.7.1	N/R
dc unbalance of power source 1	10.7.1.1	N/R
dc unbalance of power sink 1	10.7.1.2	8.1.4.7
Differential resistance in a pair of the installation wiring	10.7.1.3	N/R
Current unbalance in a pair	10.7.2	8.1.4.8
Additional requirements for an APS	10.8	N/R
Power available for an APS	10.8.1	N/R
APS switch-on time	10.8.2	N/R
APS switch-off time	10.8.3	N/R
APS power consumption when off	10.8.4	8.1.1.4, 8.1.4
Dynamic behaviour of an APS	10.8.5	N/R
Additional requirements for NT1 restricted mode source for compatibility with an APS	10.9	N/R
Power source 1 restricted mode back-off	10.9.1	N/R
Power source 1 restricted mode power up	10.9.2	N/R
NT1 power consumption from APS normal mode	10.9.3	N/R

4.10 Interface connector contact assignment

Requirements	Clause / subclause in ETS 300 012-1 [8]	Test defined in clause / subclause of this ETS
Interface connector contact assignments	11	5.1.1, 8.1.1.1

4.11 Annexes

Requirements	Clause / subclause in ETS 300 012-1 [8]	Test defined in clause / subclause of this ETS
Wiring configurations and round trip delay considerations used as a basis for electrical characteristics	Annex A	N/R
Introduction	A.1	N/R
Wiring configurations	A.2	N/R
Point-to-multipoint	A.2.1	N/R
Short passive bus	A.2.1.1	N/R
Extended passive bus	A.2.1.2	N/R
Point-to-point	A.2.2	N/R
Test configurations	Annex B	N/R
Test loopbacks defined for the basic user-network interface	Annex C	N/R
Introduction	C.1	N/R
Loopback mechanism definitions	C.2	N/R
Test loopback reference configuration	C.3	N/R
Test loopback characteristics	C.4	N/R
Additional requirements applicable to the (explicite) S reference point	Annex D	N/R
Introduction	D.1	N/R
References	D.2	N/R
Definitions	D.3	N/R
Private network termination	D.3.1	N/R
Terminal equipment	D.3.2	N/R
Conformance	D.4	N/R
Requirements	D.5	N/R
Provision of power	D.6	N/R
SDL representation of activation/deactivation procedures for TEs and NTs	Annex F	N/R
SDL representation of activation/deactivation procedures for TEs which can detect power source 1 or power source 2	F.1	N/R
SDL representation of activation/deactivation procedures for NTs	F.2	N/R
Multi-framing mechanism	Annex G	N/R
Multi-framing	G.1	N/R
General mechanism	G.1.1	N/R
Q-bit position identification algorithm	G.1.2	N/R
TE multiframe identification	G.1.3	N/R
S-channel structuring algorithm	G.2	N/R

5 Functional characteristic tests

5.1 Binary organization of frame

5.1.1 Test A

Reference: ETS 300 012-1 [8], subclauses 6.5.2.1, 6.4 and 6.6.

Purpose: To check the binary organization of INFO 3 frames.

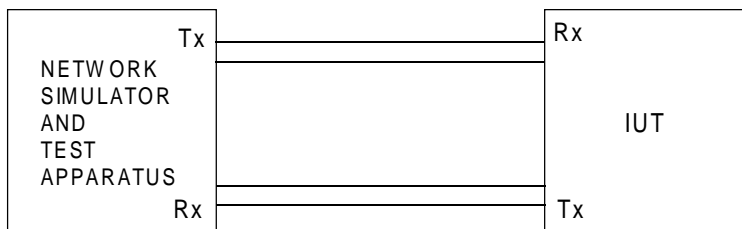

Figure 1: Test configuration

System state: Activated by the network simulator (state F7). IUT transmitting a pseudo-random data pattern (word length $\geq 2^9-1$) in the B-channels and idle channel code or messages in the D-channel.

Stimulus: INFO 4 type frames from the NT simulator. F_A bit set to binary ZERO.

NOTE: If the IUT does not provide a loopback, an access to the B-channel of the IUT is used for sending pseudo-random pattern (see clause A.2).

Monitor: The frame structure from the TE (positive pulses, negative pulses and bit and frame timing are available).

Results: See table 1.

Table 1: Results of test

BIT POSITION	DESCRIPTION	POLARITY
1	F-bit	positive pulse
2	L-bit	negative pulse
3-10	B1 octet	first binary ZERO coded negative, the following bits may be positive, negative or no pulse
11	L-bit	positive or no pulse
12	D-bit	negative or no pulse
13	L-bit	positive or no pulse
14	F _A	negative pulse
15	L-bit	positive pulse
16-23	B2 octet	first binary ZERO coded negative, the following bits may be positive, negative or no pulse
24	L-bit	positive or no pulse
25	D-bit	negative or no pulse
26	L-bit	positive or no pulse
27-34	B1 octet	first binary ZERO coded negative, the following bits may be positive, negative or no pulse
35	L-bit	positive or no pulse
36	D-bit	negative or no pulse
37	L-bit	positive or no pulse
38-45	B2 octet	first binary ZERO coded negative, the following bits may be positive, negative or no pulse
46	L-bit	positive or no pulse
47	D-bit	negative or no pulse
48	L-bit	positive or no pulse
NOTE 1: L = balance bit which is used to ensure even parity of data fields.		
NOTE 2: See figure 3, subclause 6.4.2 of ETS 300 012-1 [8] for details of pulse polarity.		
NOTE 3: Multi-framing procedure is not covered by this test.		

5.1.2 Test B

Reference: ETS 300 012-1 [8], subclause 7.3.

Purpose: To check the binary organization of INFO 1 frames.

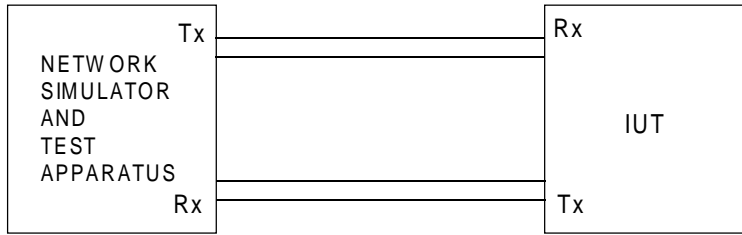

Figure 2: Test configuration

System state: Awaiting signal (state F4).

Stimulus: Activation request from the IUT (PH-AR).

Monitor: Line signals.

Results: Check that the 9 bit pattern is contiguous and of the appropriate polarity.

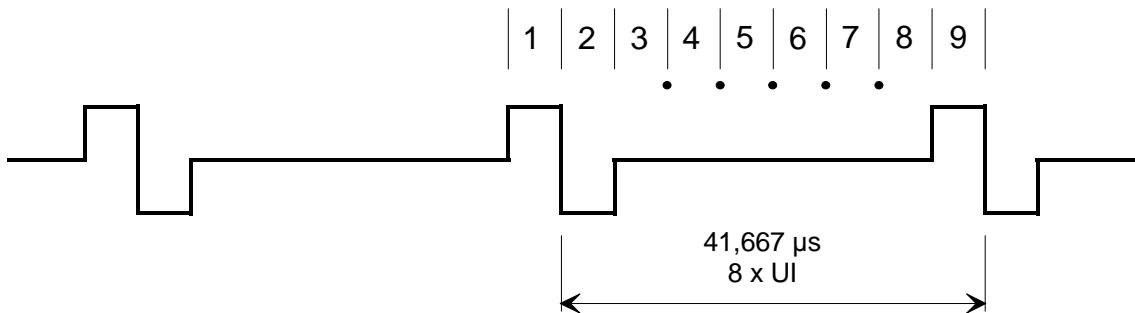

6 Interface procedure tests

These tests are designed to test conformance to the specification of the interface procedures described in ETS 300 012-1 [8], clause 7. The tests are performed by stimulating and monitoring the TE from the bus at the T reference point and from activation requests of the user.

6.1 D-channel access control procedure

Reference: ETS 300 012-1 [8], subclause 7.1

6.1.1 Interframe (layer 2) time fill

Reference: ETS 300 012-1 [8], subclause 7.1.1.

Purpose: To check the D-channel contains the correct interframe time fill from the TE.

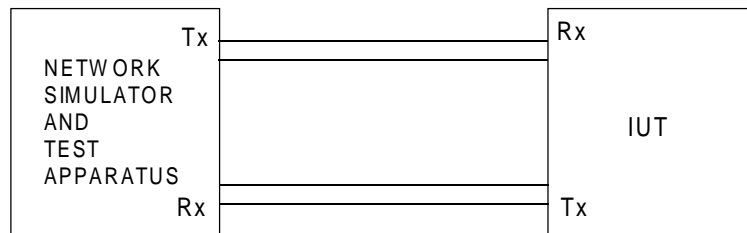

Figure 3: Test configuration

System state: Activated (state F7).

NOTE: The layer 2 shall be in a state where it does not attempt to transmit any data.

Stimulus: Interframe time fill on the D-channel.

Monitor: D-channel at the monitor port of the network simulator.

Results: Binary ONES.

6.1.2 D-echo channel response

Reference: ETS 300 012-1 [8], subclauses 7.1.3, 7.1.4 and 7.1.5.

Purpose: To check if the TE detects collisions on the D-channel when transmitting, by means of the D-echo channel and ceases transmission immediately.

To check if the TE changes the priority level correctly within its priority class.

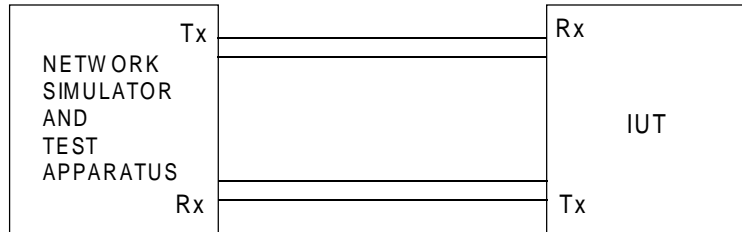

Figure 4: Test configuration

System state: Activated (state F7).

Stimulus: D-channel data from the terminal side corrupted and returned in the D-echo channel.

Monitor: D-channel from the TE.

Results:

Result to test (a) "MISMATCH"

Ensure that when the TE receives a binary ONE instead of a binary ZERO (network error) or a binary ZERO instead of a binary ONE (collision), the TE detects the mismatch and ceases transmission immediately, i. e. the next D-bit received from the TE following the application of the stimulus is set to the idle condition (binary ONE). This shall be ensured in each priority class and level which apply to the TE.

NOTE: The value of the subsequent bits is related to the priority class and priority level within the class and is covered by tests (b) and (c).

The test shall be performed with binary ONE and binary ZERO.

Result to test (b) "PRIORITY CLASS"

Ensure that after receipt by the TE of an errored D-echo channel bit, the TE while at the normal priority level receives at least 8 (for priority class 1) or at least 10 (for priority class 2), according to the priority class of the layer 2 frame to be transmitted, contiguous D-echo channel bits set to binary ONE before transmission recommences.

Result to test (c) "PRIORITY LEVEL"

Ensure that after successful transmission of a layer 2 frame, the TE does:

- not commence the transmission of a subsequent layer 2 frame until after the receipt of at least 9 (for priority class 1) or at least 11 (for priority class 2) contiguous D-echo channel bits set to binary ONE;
- change back to normal priority level after the receipt of 9 (for priority class 1) or 11 (for priority class 2) contiguous D-echo channel bits set to binary ONE if no frame is available to be transmitted.

6.2 Activation/deactivation

Reference: ETS 300 012-1 [8], subclause 7.2

6.2.1 Activation/deactivation procedure

Reference: ETS 300 012-1 [8], subclause 7.2.

Purpose: To check the terminal correctly executes the activation/deactivation procedure.

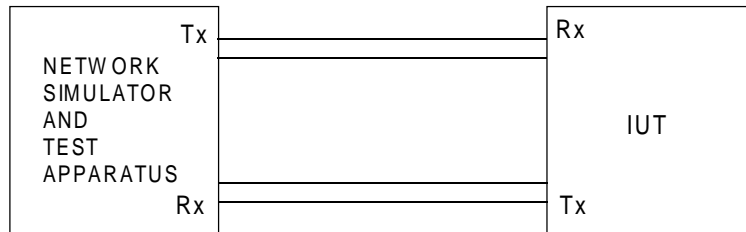

Figure 5: Test configuration

System state: Any state.

Stimulus: Power source 1 connected and disconnected, line signals INFOs 0, 2, 4 and any signal applied from the network and activation request (PH-AR) from the IUT.

Monitor: Line signals: INFOs 0, 1 and 3 at the network simulator.

Results: New state, transmitted signal (as described in table 2), and primitives sent to the higher layers according to tables 5, 6 or 7 in ETS 300 012-1 [8].

Table 2: Stimuli and resulting state changes

STATE NO	CURRENT STATE	STIMULUS	NOTE	NEXT STATE	INFO SENT	COMMENT
1	F1	Power	1	F2	INFO 0	Detection of power
2	F1	T3 expires	2, 6	F1	INFO 0	No action
3	F2	Loss of Power		F1	INFO 0	Return to inactive state
4	F2	Rx INFO 0	4	F3	INFO 0	Assume deactivated state
5	F2	Rx INFO 2		F6	INFO 3	Synchronized state
6	F2	Rx INFO 4		F7	INFO 3	Activated
7	F2	Rx any signal	3	F2	INFO 0	No action
8	F2	T3 expires	6	F2	INFO 0	No action
9	F3	Loss of power	9	F1	INFO 0	Return to inactive
10	F3	PH-AR		F4	INFO 1	Initiate activation and T3
11	F3	Rx INFO 0	4	F3	INFO 0	No action
12	F3	Rx INFO 2		F6	INFO 3	Synchronized state
13	F3	Rx INFO 4		F7	INFO 3	Activated
14	F3	Rx any signal	3	F3	INFO 0	No action
15	F3	T3 expires	2	F3	INFO 0	No action
16	F4	Loss of power	9	F1	INFO 0	Return to inactive state
17	F4	Rx INFO 0	4	F4	INFO 1	No action
18	F4	Rx INFO 2	7	F6	INFO 3	Synchronized
19	F4	Rx INFO 4	7	F7	INFO 3	Active
20	F4	Rx any signal	3	F5	INFO 0	Detection of signal
21	F4	T3 expires	2	F3	INFO 0	Deactivated
22	F5	Loss of power	9	F1	INFO 0	Return to inactive
23	F5	Rx INFO 0	4	F5	INFO 0	No action
24	F5	Rx INFO 2		F6	INFO 3	Synchronized
25	F5	Rx INFO 4		F7	INFO 3	Activated
26	F5	Rx any signal	3	F5	INFO 0	No action
27	F5	T3 expires	2	F3	INFO 0	Deactivated
28	F6	Loss of power	8	F1	INFO 0	Return to inactive
29	F6	Lost framing		F8	INFO 0	Loss of framing signals
30	F6	PH-AR		F6	INFO 3	No action
31	F6	Rx INFO 0	4	F3	INFO 0	Deactivated
32	F6	Rx INFO 2		F6	INFO 3	No action
33	F6	Rx INFO 4		F7	INFO 3	Activated
34	F6	T3 expires	2	F6	INFO 3	Synchronized
35	F7	Loss of power	8	F1	INFO 0	Return to inactive
36	F7	Lost framing		F8	INFO 0	Loss of framing
37	F7	Rx INFO 0	4, 5	F3	INFO 0	Deactivated
38	F7	Rx INFO 2		F6	INFO 3	Synchronized
39	F7	Rx INFO 4		F7	INFO 3	No action
40	F8	Loss of power	9	F1	INFO 0	Return to inactive
41	F8	PH-AR		F8	INFO 0	No action
42	F8	Rx INFO 0	4, 5	F3	INFO 0	Deactivation
43	F8	Rx INFO 2		F6	INFO 3	Synchronized
44	F8	Rx INFO 4		F7	INFO 3	Activated
45	F8	Rx any signal	3	F8	INFO 0	No action
46	F8	T3 expires	2	F3	INFO 0	Deactivated
NOTE 1:	Because the IUT can be powered in different ways, it is useful to test this IUT with the possible power it is able to detect (PS1, PS2, local power).					
NOTE 2:	T3 is implementation dependent, not to exceed 30 s.					
NOTE 3:	"Any signal" is simulated by any bit pattern on which the IUT conforming to subclause 8.1.2, ETS 300 012-1 [8] is not able to synchronize.					
NOTE 4:	For testing purposes INFO 0 is simulated by a sinusoidal signal having a voltage of 100 mV peak to peak (with a frequency in the range of 2 kHz to 1 000 kHz). The TE shall react by transmitting INFO 0 within a period time 250 μs to 25 ms.					
NOTE 5:	The PH-DI corresponding to the reception of INFO 0 shall be delivered to layer 2 only if layer 1 does not re-enter an active state before the expiration of a timer of which the value is in the range between 500 ms and 1 s.					
NOTE 6:	Applicable only for TEs which are locally powered and able to detect PS1 or PS2.					
NOTE 7:	If INFO 2 or INFO 4 is not recognized within 5 ms after the appearance of a signal, the TE shall go to F5. The result is to be tested 5 ms after generation of the stimulus.					
NOTE 8:	For TEs which are locally powered and able to detect PS1 or PS2, at the event "disappearance of power" in states F6 or F7, no state change shall be observed.					
NOTE 9:	Locally powered TEs with disconnect detector shall not assume disconnection and shall not take any action until the voltage of the interface has remained below 24 V for at least 500 ms (refer to subclause 10.6.1).					

6.2.2 Timer for activation/deactivation

6.2.2.1 Timer for activation when receiving INFO 2

6.2.2.1.1 Test A in state F3

Reference: ETS 300 012-1 [8], subclauses 7.1.1 and 5.2.1.

Purpose: To check the TE activation times in the deactivated state.

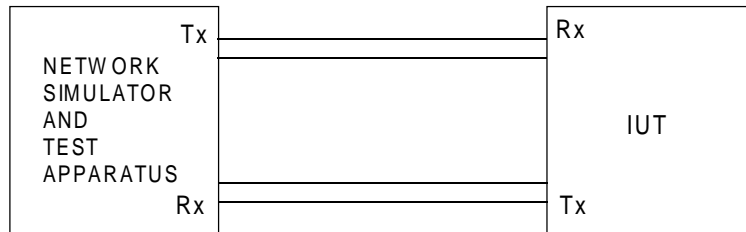

Figure 6: Test configuration

System state: Deactivated (state F3).

Stimulus: INFO 2 type frames from the network.
This test shall be performed with both normal and reversed polarity of the interchange circuit (NT to TE direction).

Monitor: The line signals with a digital storing oscilloscope, measuring the elapsed time between reception of INFO 2 and the subsequent transmission of INFO 3.

Results: INFO 3 is transmitted within 100 ms.

6.2.2.1.2 Test B in state F4

Reference: ETS 300 012-1 [8], subclause 7.1.1.

Purpose: To check the value of the TE activation times in the waiting for signal state.

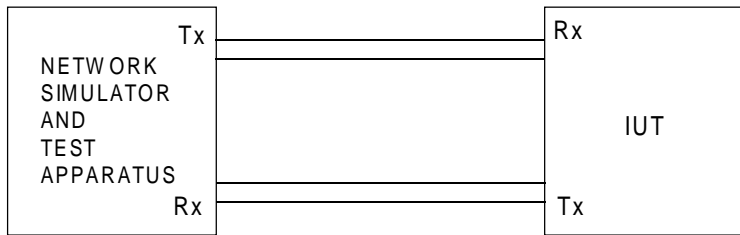

Figure 7: Test configuration

System state: Awaiting signal (state F4).

Stimulus: INFO 2 type frames from the network.

Monitor: The line signals with a digital storage oscilloscope, measuring the elapsed time between:

- a) reception of INFO 2 and cessation of INFO 1;
- b) reception of INFO 2 and the subsequent transmission of INFO 3;

during activation by the terminal.

Results: INFO 1 ceases within 5 ms of the receipt of INFO 2 and INFO 3 is transmitted within 100 ms.

6.2.2.2 Timer for activation when receiving INFO 4

Reference: ETS 300 012-1 [8], subclause 7.1.1.

6.2.2.2.1 Test A in state F3

Reference: ETS 300 012-1 [8], subclause 7.1.1.

Purpose: To check the value of the TE activation times in the deactivated state.

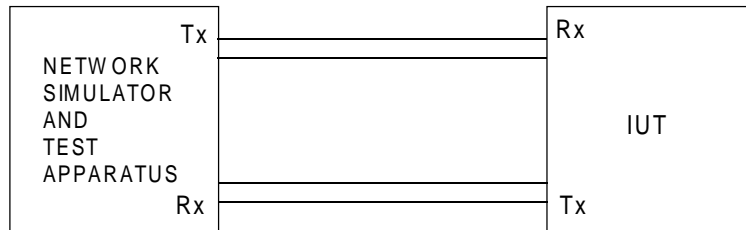

Figure 8: Test configuration

System state: Deactivated (state F3).

Stimulus: INFO 4 type frames from the network.

Monitor: The line signals with a digital storage oscilloscope, measuring the elapsed time between reception of INFO 4 and the subsequent transmission of INFO 3.

Results: INFO 3 is transmitted within 100 ms.

6.2.2.2.2 Test A in state F4

Reference: ETS 300 012-1 [8], subclause 7.1.1.

Purpose: To check the value of the TE activation times in the waiting for signal state.

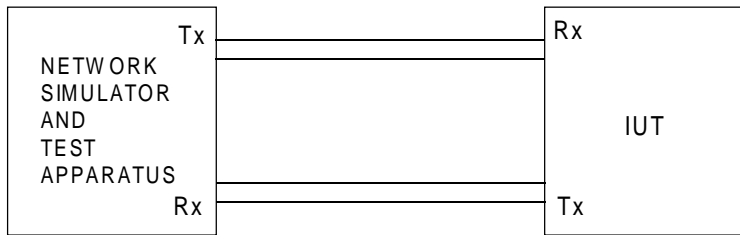

Figure 9: Test configuration

System state: Awaiting signal (state F4).

Stimulus: INFO 4 type frames from the network.

Monitor: The line signals with a digital storage oscilloscope, measuring the elapsed time between:

- a) reception of INFO 4 and cessation of INFO 1;
- b) reception of INFO 4 and the subsequent transmission of INFO 3;

during activation by the terminal.

Results: INFO 1 ceases within 5 ms of the receipt of INFO 4 and INFO 3 is transmitted within 100 ms.

6.2.2.3 Timer for activation when receiving any signal

Reference: ETS 300 012-1 [8], subclause 7.1.1.

Purpose: To check the value of the TE activation times in the waiting for signal state.

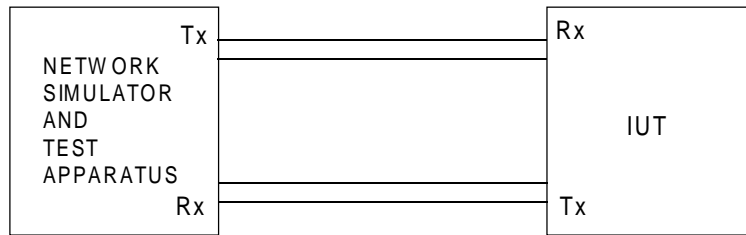

Figure 10: Test configuration

System state: Awaiting signal (state F4).

Stimulus: Any signal type frames from the network.

Monitor: The line signals with a digital storage oscilloscope, measuring the elapsed time between reception of any signal and cessation of INFO 1.

Results: INFO 1 ceases within 5 ms of the receipt of any signal.

6.2.2.4 Value of the timer T3

Reference: ETS 300 012-1 [8], subclause 7.6.

Purpose: To check the value of the TE activation times in the waiting for signal state.

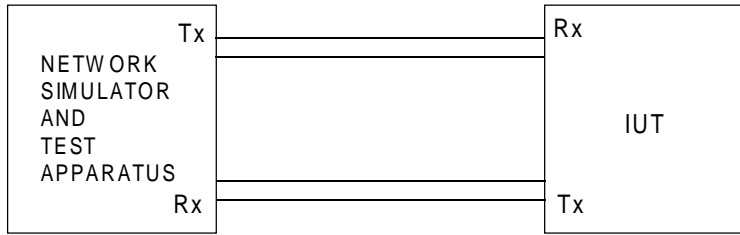

Figure 11: Test configuration

System state: Awaiting signal (state F4).

Stimulus: Activated by the IUT (PH-AR) activation request (this occurs during the normal activation procedure).

Monitor: The line signals with a digital storage oscilloscope, measuring the elapsed time between the beginning of INFO 1 and its cessation.

Results: Timer T3 shall not exceed 30 s.

6.2.2.5 Timer for physical deactivation

Reference: ETS 300 012-1 [8], subclause 7.8.

6.2.2.5.1 Test A in state F6

Reference: ETS 300 012-1 [8], subclause 7.8.

Purpose: To check the value of the TE deactivation times.

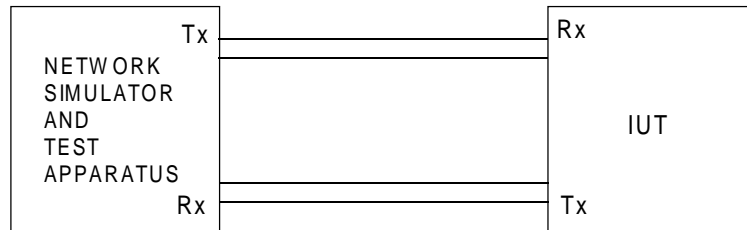

Figure 12: Test configuration

System state: Synchronized (state F6).

Stimulus: INFO 0 from the network (see note 4 in table 2, subclause 6.2.1).

Monitor: The line signals with a digital storage oscilloscope, measuring the elapsed time between reception of INFO 0 and cessation of INFO 3 (sending INFO 0).

Results: INFO 3 ceases within 250 μ s to 25 ms.

NOTE: The zero time reference point starts immediately after the 48th bit of the last received frame different from INFO 0.

6.2.2.5.2 Test B in state F7

Reference: ETS 300 012-1 [8], subclause 7.8.

Purpose: To check the value of the TE deactivation times.

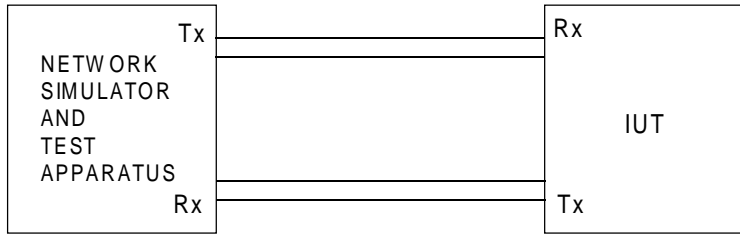

Figure 13: Test configuration

System state: Activated (state F7).

Stimulus: INFO 0 from the network (see note 4 in table 2, subclause 6.2.1).

Monitor: The line signals with a digital storage oscilloscope, measuring the elapsed time between reception of INFO 0 and cessation of INFO 3 (sending INFO 0).

Results: INFO 3 ceases within 250 μ s to 25 ms.

NOTE: The zero time reference point starts immediately after the 48th bit of the last received frame different from INFO 0.

6.2.2.6 Timer for complete deactivation

Reference: ETS 300 012-1 [8], note 6 in table 5, subclause 7.4.2.

6.2.2.6.1 Test A in state F7

Reference: ETS 300 012-1 [8], note 6 in table 5, subclause 7.4.2.

Purpose: To check the value of the timer when leaving state F7 upon the reception of INFO 0.

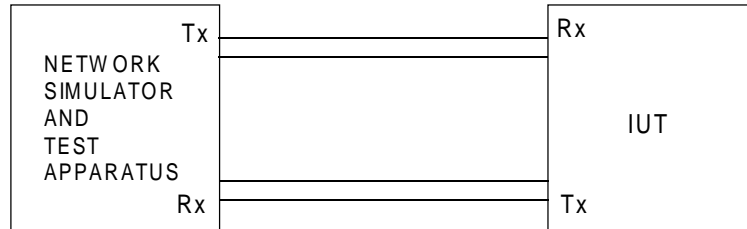

Figure 14: Test configuration

System state: Activated (state F7) with an ongoing communication established.

Stimulus: INFO 0 from the network simulator (see note 4 in table 2, subclause 6.2.1) and then INFO 4.

Monitor: The ongoing communication.

Results: The value of the timer is in the range of 500 ms to 1 000 ms.

If the duration of INFO 0 from the network is less than 500 ms:
no loss of the ongoing communication.

If the duration of INFO 0 from the network is greater than 1 000 ms:
loss of the ongoing communication

NOTE: This test applies for IUT where layer 3 timer T309 (defined in ETS 300 102-1 [7]) is not implemented.

6.2.2.6.2 Test B in state F8

Reference: ETS 300 012-1 [8], note 6 in table 5, subclause 7.4.2.

Purpose: To check the value of the timer when leaving state F8 upon the reception of INFO 0.

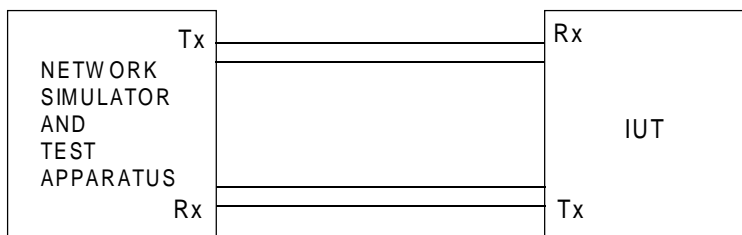

Figure 15: Test configuration

System state: Lost framing (state F8). With an ongoing communication established.

Stimulus: INFO 0 and then INFO 4 from the network simulator (see note 4 in table 2, subclause 6.2.1).

Monitor: The ongoing communication.

Results: The value of the timer is in the range of 500 ms to 1 000 ms.

If the duration of INFO 0 from the network is less than 500 ms:
no loss of the ongoing communication.

If the duration of INFO 0 from the network is greater than 1 000 ms:
loss of the ongoing communication

NOTE: This test applies for IUT where layer 3 timer T309 (defined in ETS 300 102-1 [7]) is not implemented.

6.3 Frame alignment procedures

Reference: ETS 300 012-1 [8], clause 8.

Purpose: To test the IUT correctly executes the frame alignment procedures.

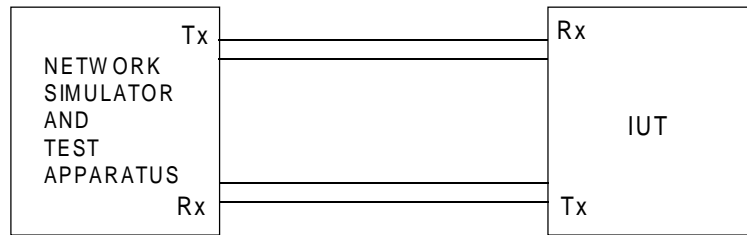

Figure 16: Test configuration

System state: Activated (state F7).

Stimulus: Good/bad frames from the network simulator.

NOTE 1: A bad frame is simulated by any bit pattern on which the IUT conforming to subclause 8.1.2 of ETS 300 012-1 [8] is not able to synchronize.

NOTE 2: The start of a frame is defined to the position where the F-bit according to figure 3 in ETS 300 012-1 [8] should appear.

NOTE 3: Before the test of frame regain, the TE shall be in state F8. The input shall be applied with "Any signal". Multi-framing is not covered by this test.

Monitor: Line signals INFO 3 received from the IUT at the network simulator.

Results: Line signals according to table 3.

Table 3: Framing procedures; stimuli and resulting line signals at the network simulator

	Stimulus	Results	Comments
a)	1 bad frame	INFO 3	No loss of framing
b)	5 bad frames	INFO 0	Framing lost
c)	2 good frames	INFO 0	Framing not regained
d)	6 good frames	INFO 3	Framing regained

6.4 Multi-framing procedures

Reference: ETS 300 012-1 [8], subclause 8.3.

Purpose: To test the IUT correctly executes the multi-framing procedures.

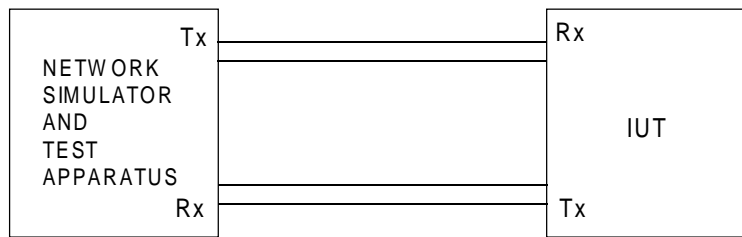

Figure 17: Test configuration

System state: Activated (state F7).

Stimulus: Transmission of the Fa/N bit pairs from the network simulator indicating normal and the multiframe bit sequence.

Normal Fa = ZERO N = ONE
Multiframe Fa = ONE N = ZERO

Monitor: Line signals INFO 3 received from the IUT at the network simulator.

Results: When network sends Fa = ZERO, returned Fa from IUT = ZERO.
When network sends Fa = ONE, returned Fa from IUT (Q-bit) = ONE.

6.5 Idle channel code on the B-channels

Reference: ETS 300 012-1 [8], subclause 8.4.

Purpose: To check the contents of all non-assigned B-channels.

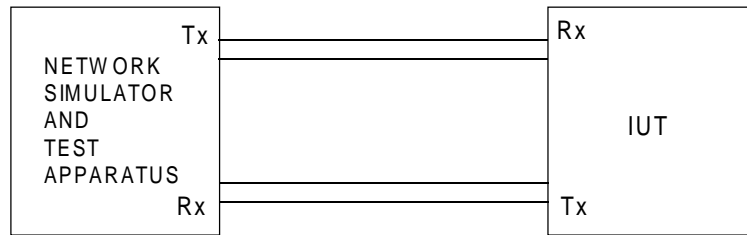

Figure 18: Test configuration

System state: Activated (state F7).

Stimulus: INFO 4.

Monitor: B-channel at the monitor port of the network simulator.

Results: Binary ONES.

7 Electrical characteristics tests

Reference: ETS 300 012-1 [8], clause 9.

These tests check that the interface conforms to the electrical characteristics specified in clause 9 of ETS 300 012-1 [8], the first part of this multiple-standard.

Many of these tests require the interface to be stable in the activated state and transmitting a specific bit pattern, both with or without the connection to the NT1 receiving pair. As none of these requirements can be met with the network simulator operating normally it is anticipated that special arrangements will be made to permit this, for example the receiving section to the NT1 could be manually set in the appropriate state.

There is also the restriction imposed by access to the TE's B-channels.

The characteristics measured by these tests may vary with the type of power source or power sink and the extremes of voltage provided by the network. It is therefore necessary to repeat the tests at the extremes of dc voltage levels, minimum and maximum, for local power, normal power conditions and restricted power conditions.

Moreover the IUT shall meet the specified electrical characteristics in conformance with the requirements of clause A.1 of this ETS.

When a power source 1 is used, this effect shall be taken into account in the test methodology.

7.1 Frame rate when transmitting an INFO 1

Reference: ETS 300 012-1 [8], subclause 9.1.

Purpose: The average frame rate when the TE is transmitting INFO 1 type frames.

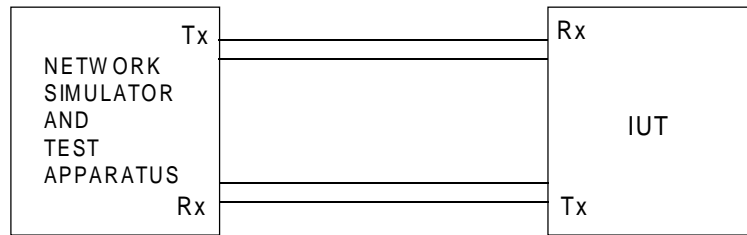

Figure 19: Test configuration

System state: Awaiting signal (state F4).

Stimulus: INFO 0 type frames from the network (see note 4 in table 2, subclause 6.2.1).

Monitor: Frame rate.

Results: Nominal frame rate of 24 kHz \pm 100 ppm.

NOTE: The bit rate in kbit/s can be calculated by multiplying the frame rate by eight.

7.2 TE jitter characteristics

7.2.1 TE jitter measurement characteristics (test A)

Reference: ETS 300 012-1 [8], subclause 9.2.2.

Purpose: TE output jitter when transmitting INFO 3 type frames.

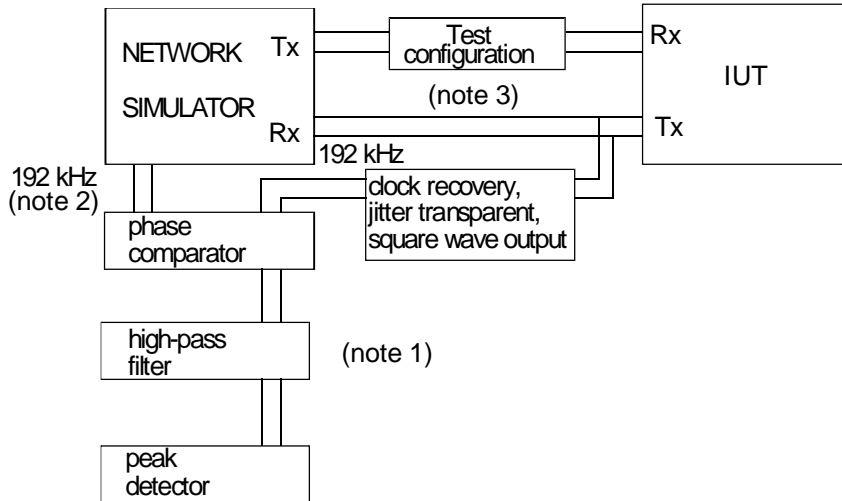

NOTE 1: For measurement purposes an additional low-pass filter with a cut-off frequency higher than 96 kHz can be added.

NOTE 2: The clock provided by the network simulator is synchronous with the signal received by the IUT.

NOTE 3: See ETS 300 012-1 [8], subclause 9.2.1 and annex B to ETS 300 012-1 [8] for test configurations.

Figure 20: Test configuration

System state: Activated (state F7).

Stimulus: INFO 4 type frames from the network containing:

- a) All binary ONEs in D, D-echo and both B-channels.
- b) A sequence repeated continuously for at least 10 s consisting of:
 - 40 frames with continuous octets of 10101010 (the first bit to be transmitted is a binary ONE), in both B-channels and continuous binary ONEs in the D- and D-echo-channels followed by:
 - 40 frames with continuous binary ZEROS in D-, D-echo and both B-channels.
- c) A sequence consisting of pseudo random pattern with a length of $2^{19}-1$ in D-, D-echo and both B-channels.

Monitor: Peak-to-peak jitter measured using a peak detector through a high-pass filter and a phase comparator. The filter shall have a low-cut frequency (3 dB point) of 30 Hz and an asymptotic roll-off of 20 dB per decade. One input of the phase comparator shall be a 192 kHz signal synchronous with the NT simulator, the other input shall be a square wave signal at 192 kHz extracted from the analogue signal transmitted from the IUT. To obtain this digital signal a square wave generator can be used triggered by all the zero crossing transitions of all adjacent binary ZEROs.

The block diagram in figure 20 is only a logical representation and it does not represent an actual implementation.

Results: The maximum jitter shall be less than $\pm 7\%$ of a bit period.

7.2.2 TE output phase deviation (test B)

Reference: ETS 300 012-1 [8], subclause 9.2.3.

Purpose: TE total phase deviation input to output.

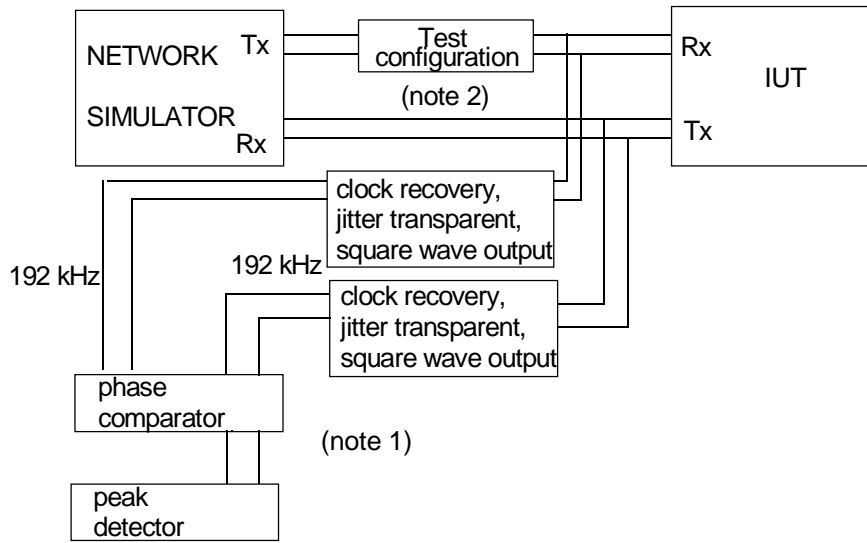

NOTE 1: For measurement purposes an additional low-pass filter with a cut-off frequency higher than 96 kHz can be added.

NOTE 2: See ETS 300 012-1 [8], subclause 9.2.1 and annex B to ETS 300 012-1 [8] for test configurations.

Figure 21: Test configuration

System state: Activated (state F7).

Stimulus: INFO 4 type frames from the network containing:

- a) A sequence consisting of continuous frames with all binary ONES in the D-, D-echo and both B-channels.
- b) A sequence consisting of continuous frames with the octet "10101010" (the first bit to be transmitted is binary ONE) in both B-channels and binary ONES in D- and D-echo-channel.
- c) A sequence of continuous frames with binary ZEROS in D-, D-echo and both B-channels.
- d) A sequence of continuous frames with a pseudo-random pattern, as described in ETS 300 012-1 [8], subclause 9.2.2 c), in D-, D-echo and both B-channels.

Superimposed jitter as specified in figure 10 in ETS 300 012-1 [8], subclause 9.2.3 at least at frequencies of 5 Hz/0,5 UI, 20 Hz/0,125 UI, 50 Hz/0,05 UI and 2 015 Hz/0,05 UI shall also be applied to the input signal from the network.

Monitor: Peak to peak jitter measured using a peak voltmeter through an additional low-pass filter (see note 1 in figure 21) and a phase comparator (see CCITT Recommendation G.117 [6]).

One input of the phase comparator shall be a 192 kHz signal synchronous with the NT simulator, the other input shall be a square wave signal extracted at 192 kHz from the analogue signal transmitted from the IUT. To obtain this digital signal a square wave generator can be used triggered by all the zero crossing transitions of all adjacent binary ZEROS.

The block diagram in figure 21 is only a logical representation and it does not represent an actual implementation.

Results: The maximum phase deviation shall be $-7\% \leq X \leq +15\%$ of a bit period.

(This phase deviation does not include the two-bit period between transmitted and received frames).

The measured deviation Y with included two bit period is equivalent to:
 $10,05 \mu\text{s} \leq Y \leq 11,20 \mu\text{s}$.

7.3 TE transmitter output impedance

Reference: ETS 300 012-1 [8], subclause 9.5.1.2.

7.3.1 Test A

Reference: ETS 300 012-1 [8], subclause 9.5.1.2.

Purpose: Output impedance of the transmitters when transmitting a binary ONE (no signal).

NOTE: This requirement also applies to the APS.

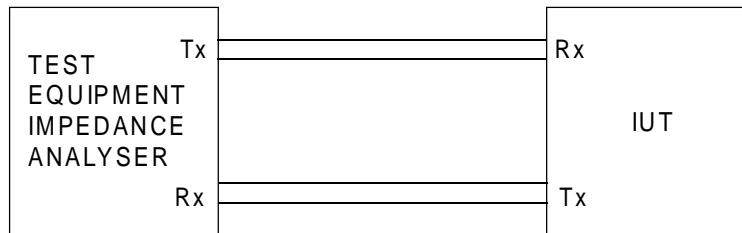

Figure 22: Test configuration

System state: Deactivated (state F3).

Stimulus: Sinusoidal voltages of 100 mV rms, in the frequency range 2 kHz to 1 000 kHz.

Monitor: Impedance.

Results: The measured value shall exceed the impedance template of figure 12 given in ETS 300 012-1 [8] subclause 9.5.1.2.

7.3.2 Test B

Reference: ETS 300 012-1 [8], subclause 9.5.1.2.

Purpose: Output impedance of the transmitters when transmitting a binary ZERO.

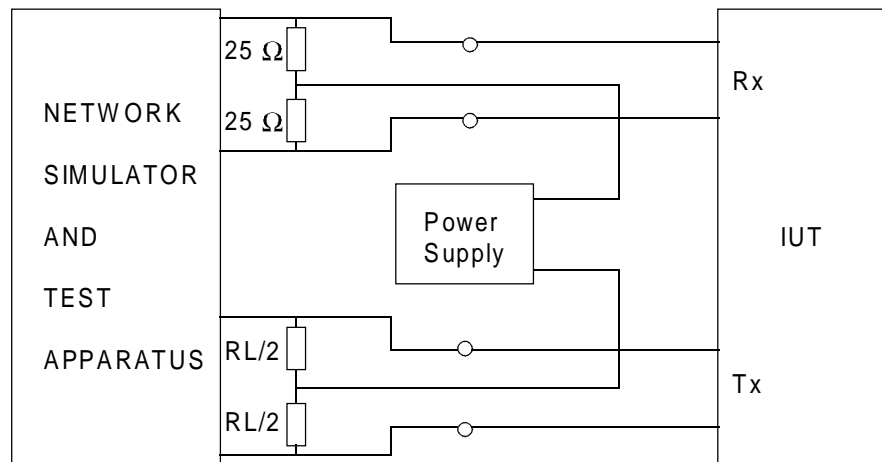

Figure 23: Test configuration

System state: Activated (state F7). IUT transmitting positive and negative pulses into a load resistance (see annex A of this ETS).

Stimulus: INFO 4.

Monitor: Both positive and negative pulses.

The output impedance limit shall apply for 2 nominal load impedance (resistive) conditions : $R_L = 50 \Omega$ and 400Ω . The output impedance for each nominal load is defined by determining the peak pulse amplitude for loads equal to the nominal value $\pm 10 \%$. The peak amplitude is defined as the amplitude of the midpoint of the pulse. The test applies for pulses of both polarities.

Results: The output impedance shall be $\geq 20 \Omega$

$$R = \frac{U^+ - U^-}{U^- / R^- - U^+ / R^+}$$

- R⁺: nominal resistance $R_L + 10 \%$.
- R⁻: nominal resistance $R_L - 10 \%$.
- U⁺: peak amplitude when R⁺ is applied.
- U⁻: peak amplitude when R⁻ is applied.

7.3.3 Test C

Reference: ETS 300 012-1 [8], subclause 9.5.1.2.

Purpose: Output peak current.

NOTE: This requirement also applies to the APS.

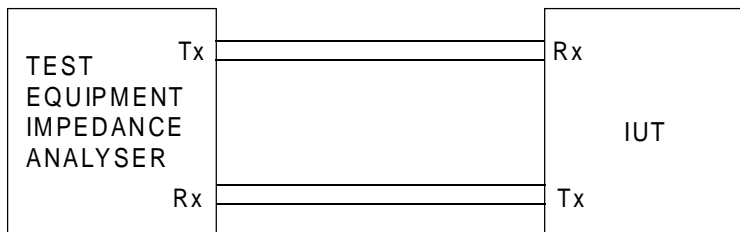

Figure 24: Test configuration

System state: Deactivated (state F3).

Stimulus: Sinusoidal voltage up to 1,2 V (peak value) at a frequency of 96 kHz (the applied voltage to be monitored with oscilloscope to ensure peak values are correct).

Monitor: Peak current.

Results: Peak current shall not exceed 0,6 mA.

7.3.4 Test D

Reference: ETS 300 012-1 [8], subclause 9.5.1.2.

Purpose: Output impedance of the transmitters in the inactive state.

NOTE: This requirement also applies to the APS.

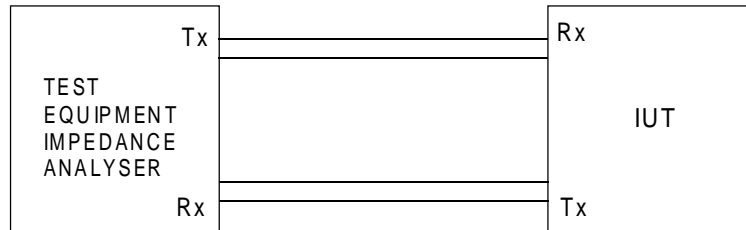

Figure 25: Test configuration

System state: Inactive (state F1).

Stimulus: Sinusoidal voltage of 100 mV rms, in the frequency range 2 kHz to 1 000 kHz.

Monitor: Impedance.

Results: The measured value shall exceed the impedance template of figure 12 given in ETS 300 012-1 [8] subclause 9.5.1.2.

When the IUT is a locally powered TE able to detect power source 1 or 2, two tests shall be performed (power off/power on without PS1 and PS2).

7.3.5 Test E

Reference: ETS 300 012-1 [8], subclause 9.5.1.2.

Purpose: Output peak current.

NOTE: This requirement also applies to the APS.

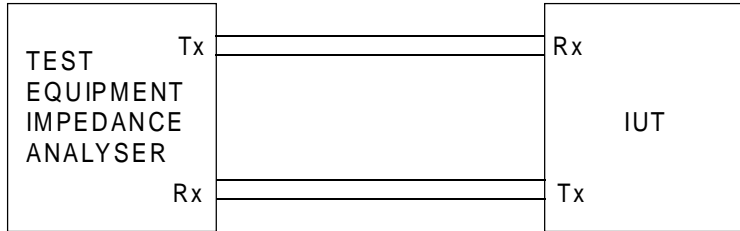

Figure 26: Test configuration

System state: Inactive (state F1).

Stimulus: Sinusoidal voltage of 1,2 V (peak value) at a frequency of 96 kHz (the applied voltage to be monitored to ensure peak values are correct).

Monitor: Peak current.

Results: Peak current shall not exceed 0,6 mA.

When the IUT is a locally powered TE able to detect power source 1 or 2, two tests shall be performed (power off/power on without PS1 and PS2).

7.4 Pulse shape and amplitude

Reference: ETS 300 012-1 [8], subclause 9.5.3.

Purpose: Pulse shape and amplitude of isolated transmitted pulses.

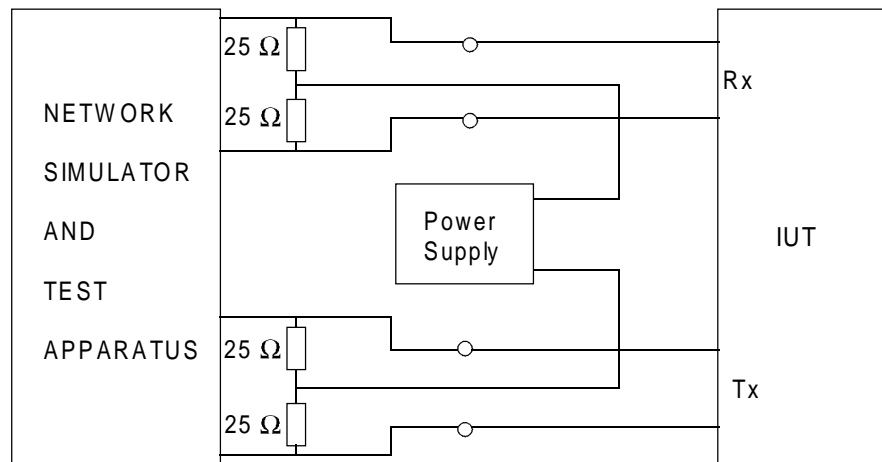

Figure 27: Test configuration

User/network interface transmitting pair terminated in 50 Ω terminating resistor, i.e. NT1 receiving circuiting connected without its terminating resistor.

System state: Activated (state F7).

IUT transmitting isolated pulses (no adjacent pulses) into a normally terminated bus (see annex A).

Stimulus: Isolated pulses of normal amplitude.

Monitor: Both positive and negative pulses.

Results: Both positive and negative pulses shall be within the mask of figure 13 in ETS 300 012-1 [8] with a nominal amplitude of 750 mV zero to peak.

7.5 Pulse unbalance

Reference: ETS 300 012-1 [8], subclause 9.5.4.

7.5.1 Pulse amplitude

Reference: ETS 300 012-1 [8], subclause 9.5.4.1.

Purpose: Pulse amplitude when transmitting a high density pattern.

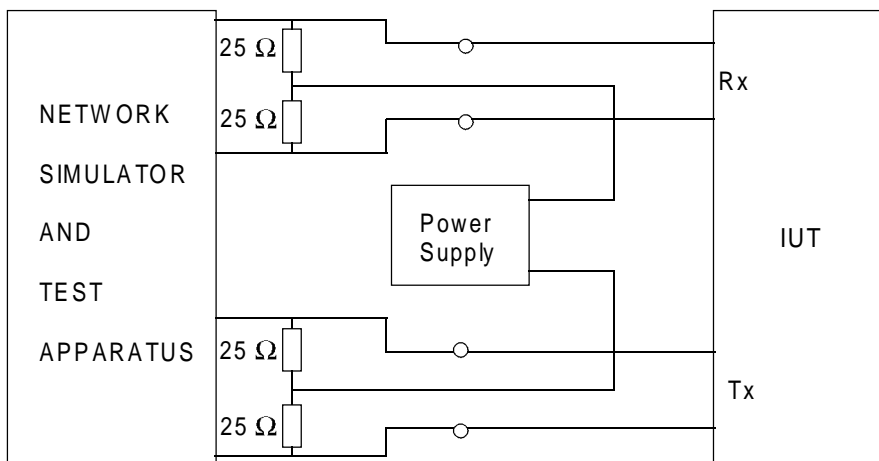

Figure 28: Test configuration

System state: Activated (state F7).

IUT transmitting INFO 3 with both B-channels filled with binary ZEROs.

Stimulus: INFO 4.

Monitor: The amplitude of positive and negative pulses at the midpoint of the pulse.

Results: All pulses amplitude of 40 continuous frames in the midpoint of the pulse shall be within the $\pm 10\%$ of the nominal amplitude values.

7.5.2 Pulse unbalance of an isolated couple of pulses

Reference: ETS 300 012-1 [8], subclause 9.5.4.2.

Purpose: The relative difference in $\int U(t)dt$ for a positive and negative pulse.

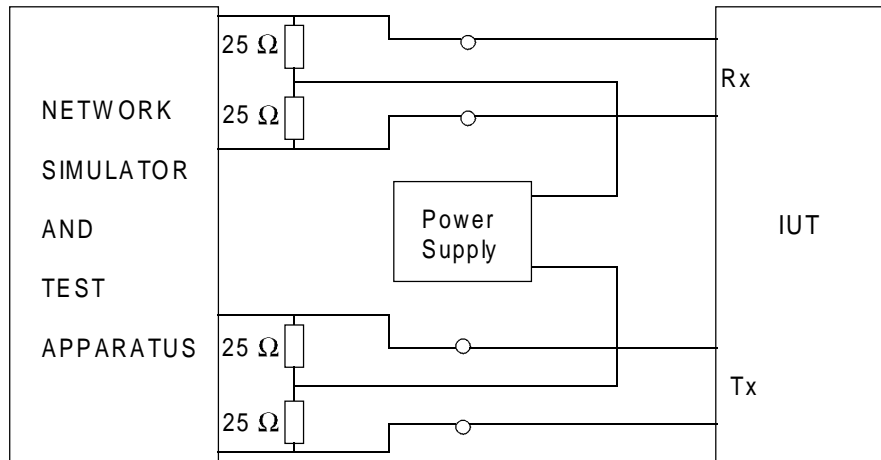

Figure 29: Test configuration

System state: a) Deactivated (state F3), then
b) Synchronized (state F6).

IUT transmitting INFO 3 containing all binary ONEs in both B-channels (Idle pattern).

Stimulus: INFO 2.

Monitor: a) voltage when transmitting INFO 0.
b) first isolated couple of pulses of the first INFO 3 following INFO 0.

Results: The relative difference (note) in $\int U(t)dt$ for a positive pulse and the $\int U(t)dt$ for a negative pulse shall be less than 5 % of the nominal pulse. The zero reference voltage is given by the signal when transmitting INFO 0.

NOTE: The edge between the two adjacent pulses is the crossing of the zero voltage. From this edge, the integral is defined for a time period of 1,5 UI in each direction.

7.6 Voltage on other test loads

Reference: ETS 300 012-1 [8], subclause 9.5.5.

7.6.1 Test A

Reference: ETS 300 012-1 [8], subclause 9.5.5.1.

Purpose: Voltage, on a 400 Ω test load, to prevent pulses adding when 2 to 8 drivers are in parallel.

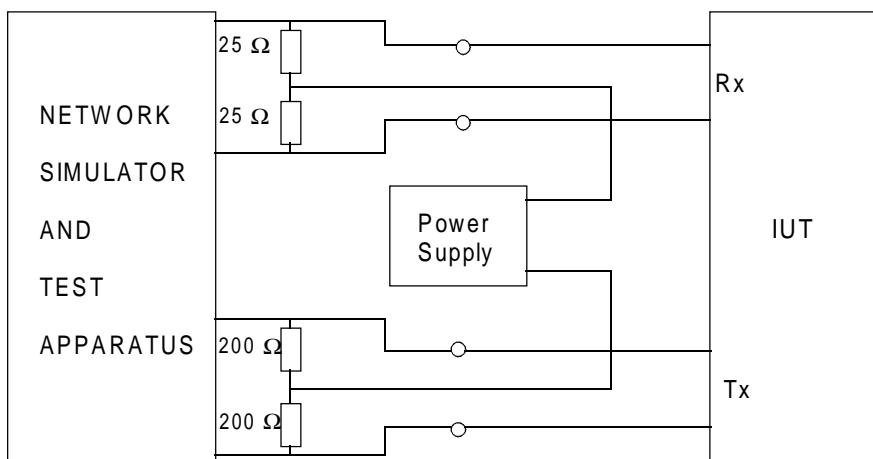

Figure 30: Test configuration

System state: Activated (state F7).

TE transmitting isolated pulses (no adjacent pulses) into a 400 Ω load. (See annex A).

Stimulus: INFO 4.

Monitor: Both positive and negative pulses.

Results: The pulses shall fit into the mask defined in ETS 300 012-1 [8], figure 14.

7.6.2 Test B

Reference: ETS 300 012-1 [8], subclause 9.5.5.2.

Purpose: Voltage on a 5,6 Ω test load, to prevent current flow when two opposite polarity drivers are in parallel.

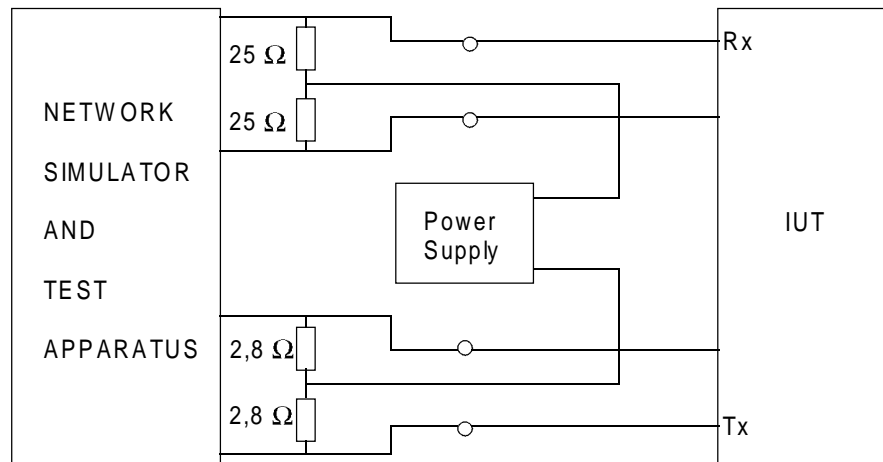

Figure 31: Test configuration

System state: Activated (state F7).

Transmitting isolated pulses (no adjacent pulses) into 5,6 Ω load (see annex A).

Stimulus: INFO 4.

Monitor: Both positive and negative pulses.

Results: The measured pulses shall be $\leq 20\%$ of the nominal pulse amplitude.

7.7 Longitudinal conversion loss of transmitter output

Reference: ETS 300 012-1 [8], subclause 9.5.6.1.

Purpose: Longitudinal Conversion Loss (LCL) (the ratio of longitudinal signal converted to a transverse signal as a result of the unbalance about earth of the terminal output).

NOTE: These requirements also apply to the APS.

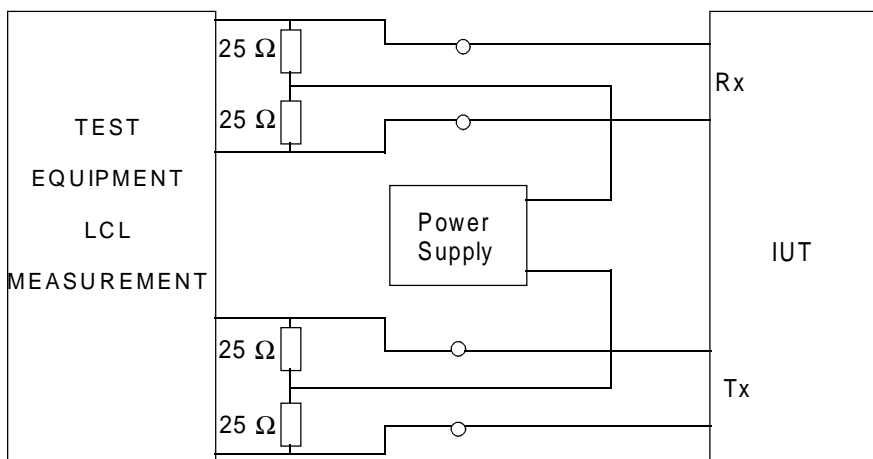

Figure 32: Test configuration

Measurement test configuration: See figure 15 in ETS 300 012-1 [8].

System state: a) Deactivated (state F3).
b) Inactive (state F1).

Stimulus: 1 V rms longitudinal in accordance with figure 15 in ETS 300 012-1 [8].

Monitor: Transverse voltage in accordance with figure 15 in ETS 300 012-1 [8] with selective level measuring instrument.

Results: 10 kHz \leq f \leq 300 kHz: \geq 54 dB;
300 kHz $<$ f \leq 1 MHz: minimum value decreasing from 54 dB at 20 dB/decade.

7.8 Receiver input characteristics

Reference: ETS 300 012-1 [8], subclause 9.6.

7.8.1 TE receiver input impedance

NOTE: These requirements also apply to the APS.

7.8.1.1 Test A

Reference: ETS 300 012-1 [8], subclause 9.6.1.1.

Purpose: To test the input impedance of terminals whilst in a deactive state.

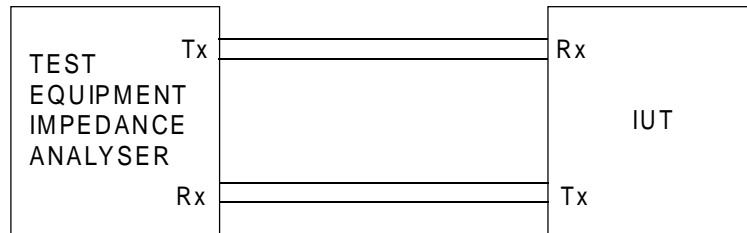

Figure 33: Test configuration

System state: Deactivated (state F3).

Stimulus: Sinusoidal voltage of at least 100 mV rms, in the frequency range 2 kHz to 1 000 kHz.

Monitor: Impedance.

Results: Shall exceed the impedance template of figure 12 in ETS 300 012-1 [8].

7.8.1.2 Test B

Reference: ETS 300 012-1 [8], subclause 9.6.1.1.

Purpose: To test that the input impedance of the receiver when receiving an overvoltage signal is correct.

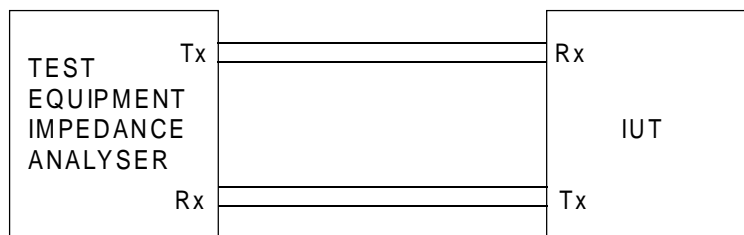

Figure 34: Test configuration

System state: Deactivated (state F3).

Stimulus: Sinusoidal voltage up to 1,2 V (peak value) at a frequency of 96 kHz (the applied voltage to be monitored to ensure peak values are correct).

Monitor: Peak value of current.

Results: The peak current shall not exceed 0,6 mA peak value.

7.8.1.3 Test C

Reference: ETS 300 012-1 [8], subclause 9.6.1.1.

Purpose: To test the input impedance of TE receivers in the inactive state.

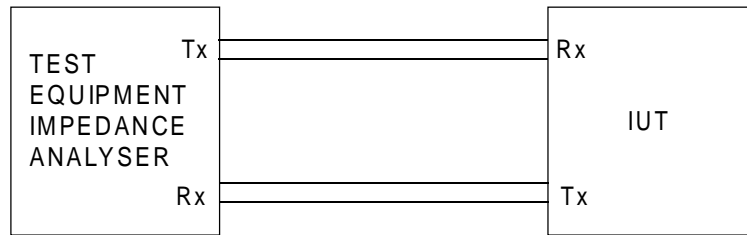

Figure 35: Test configuration

System state: Inactive (state F1).

Stimulus: Sinusoidal voltage of at least 100 mV rms, in the frequency range 2 kHz to 1 000 kHz.

Monitor: Impedance.

Results: Shall exceed the impedance template of figure 12 in ETS 300 012-1 [8].

When the IUT is a locally powered TE able to detect power source 1 or 2, two tests shall be performed (power off/power on without PS1 and PS2).

7.8.1.4 Test D

Reference: ETS 300 012-1 [8], subclause 9.6.1.1.

Purpose: To test that the input impedance of the receiver when receiving an overvoltage signal is correct.

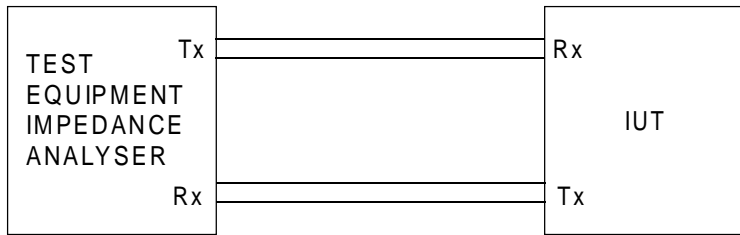

Figure 36: Test configuration

System state: Inactive (state F1).

Stimulus: Sinusoidal voltage up to 1,2 V (peak value) at a frequency of 96 kHz (the applied voltage to be monitored to ensure peak values are correct).

Monitor: Peak value of current.

Results: The peak current shall not exceed 0,6 mA peak value.

When the IUT is a locally powered TE able to detect power source 1 or 2, two tests shall be done (powered off/powering on without PS1 and PS2).

7.8.2 Receiver sensitivity - noise and distortion immunity

Reference: ETS 300 012-1 [8], subclause 9.6.2.

Purpose: To test the receiver's function in the various wiring configurations.

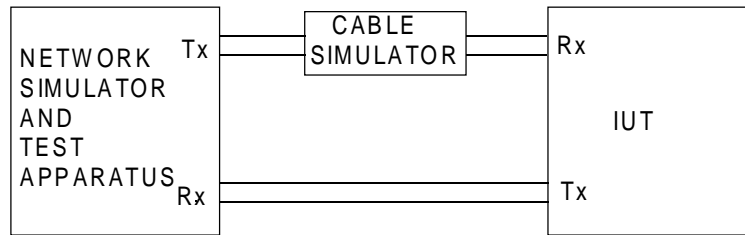

Figure 37: Test configuration

When performing this test the error rate measurement can be made either after the receiver using a B-channel access port or at the TE transmitter. If the measurement is at the TE transmitter, then the connection to the NT receiver should be in the ideal test configuration.

System state: Activated (state F7).

Stimulus: Input signals are transmitted from the network simulator with a pseudo-random sequence (word length ≥ 511 bits) in both B-channels with amplitudes, delay and interfering signals as detailed in subclause 9.6.2.1 in ETS 300 012-1 [8].

Table 4 indicates the amplitudes that are provided by the NT simulator corresponding to the bus configurations as given in subclause 9.2.1.

Table 4: Amplitudes corresponding to the bus configurations

Configuration	Amplitude relative to the nominal one
1 (see note)	- 1,5 dB at the NT simulator output
2	- 1,5 dB and + 1,5 dB at the NT simulator output
3	- 1,5 dB and + 1,5 dB at the NT simulator output
4	+ 1,5 dB at the NT simulator output
NOTE:	Additionally, the TEs shall operate with sinusoidal signals having an amplitude of 100 mV (peak-to-peak value) at frequencies of 200 kHz and 2 MHz superimposed individually on the input signals along with jitter.

In addition, for each configuration jitter up to the maximum permitted (subclause 9.2 in ETS 300 012-1 [8]) at least at frequencies of 5 Hz/0,5 UI, 20 Hz/0,125 UI, 50 Hz/0,05 UI and 2 015 Hz/0,05 UI shall be superimposed on the input signal.

Monitor: B-channels from IUT checking the error rate (see annex A).

Results: No error for a monitoring period of at least one minute.

7.8.3 Unbalance about earth of receiver input

Reference: ETS 300 012-1 [8], subclause 9.6.4.

Purpose: Longitudinal Conversion Loss (LCL) (the ratio of longitudinal signal converted to a transverse signal as a result of the unbalance about earth of the terminal output).

NOTE: These requirements also apply to the APS.

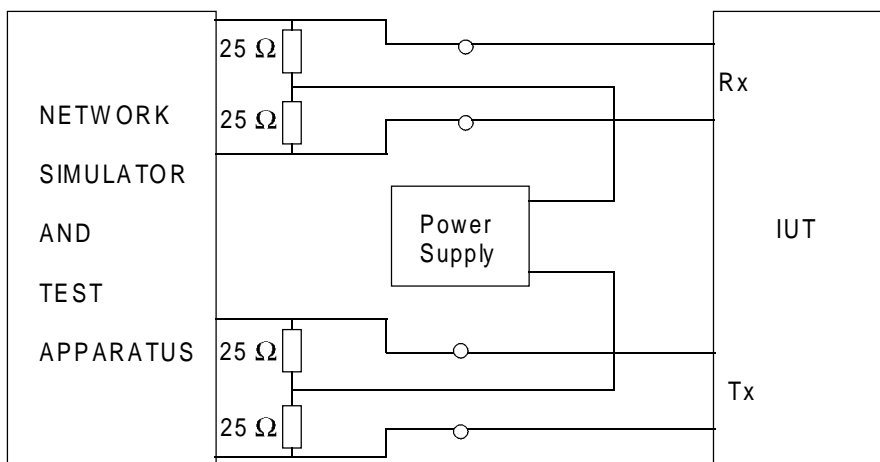

Figure 38: Test configuration

Measurement test configuration: See figure 15 in ETS 300 012-1 [8].

- System state:
- a) Deactivated (state F3).
 - b) Inactive (state F1).

Stimulus: 1 V rms longitudinal in accordance with figure 15 in ETS 300 012-1 [8].

Monitor: Transverse voltage in accordance with figure 15 in ETS 300 012-1 [8] with selective level measuring instrument.

Results: 10 kHz ≤ f ≤ 300 kHz: ≥ 54 dB;
 300 kHz < f ≤ 1 MHz: minimum value decreasing from 54 dB at 20 dB/decade.

8 Power feeding

The different values concerning power consumption are given in table 9 of ETS 300 012-1 [8].

Power feeding tests assume the following conditions:

- a) an IUT may be in any state of activation;
- b) an IUT may be making or receiving a call;
- c) at no stage of an active call may the defined values be exceeded:
 - the tests for maximum power consumption shall be conducted under conditions of maximum power consumption as declared by the supplier;
 - all the values referring to power in Watts shall be measured using an instrument which integrates the measurements over a period of 50 ms;
 - all the values referring to current in mA shall be measured using an instrument which measured instantaneous current;
 - for testing purposes, no power shall be interpreted as the TE consuming not more than 10 μ A (this gives allowance for leakage losses and inefficiencies);
 - when measuring power consumption, the power loss due to resistance in the line and the feeding transformers shall be subtracted. However, power loss due to resistance in the line transformers in the TE and in the TE cord shall not be subtracted;
 - for the simulator, all rise-times or fall times of voltage are defined between 90 % and 10 % of the voltage measured with resistive load without the IUT connected.

The requirements shall be met in all of the above conditions.

8.1 Power source 1 phantom mode

Reference: ETS 300 012-1 [8], subclause 10.3.1 and 10.4.

8.1.1 Normal power conditions

Reference: ETS 300 012-1 [8], subclause 10.3.1.1 and 10.4.1.

8.1.1.1 Normal power provision (Test A)

Reference: ETS 300 012-1 [8], subclause 10.3.1.1 and 10.4.1.

Purpose: To ensure an ACTIVATED TE does not draw excessive power from a normal mode, phantom PS1, whilst in an activated state.

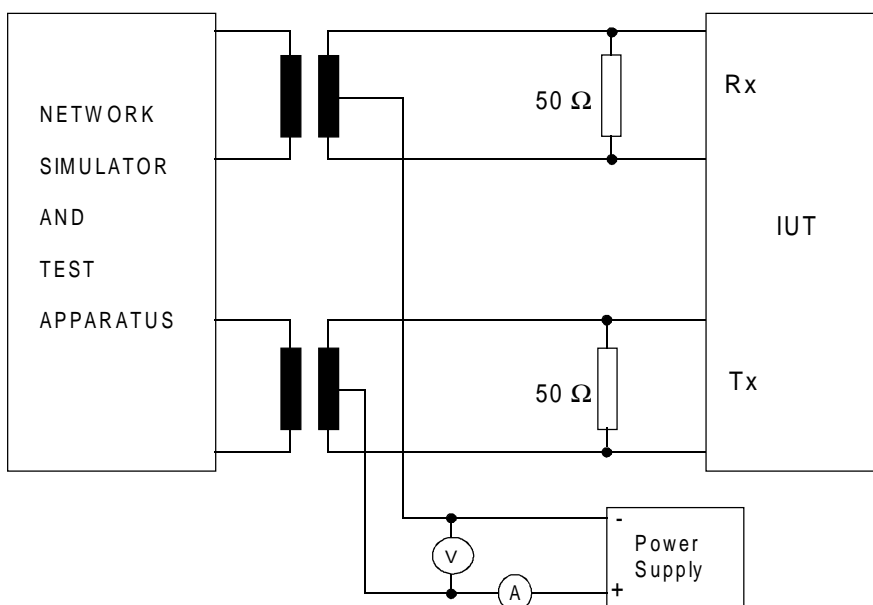

Figure 39: Test configuration

System state: Activated (state F7).

Stimulus: Phantom, normal PS1 in the voltage range 40 V, +5 %, -40 % (42 V to 24 V).

Monitor: dc voltage and current.

Results: The power drawn ($V \times I$) shall not exceed 1 W at both extremes of the power source voltage as stated in the stimulus section.

8.1.1.2 Normal power provision (Test B)

Reference: ETS 300 012-1 [8], subclause 10.3.1.1 and 10.4.1.

Purpose: To ensure the DEACTIVATED TE does not draw excessive power from a normal mode, phantom PS1.

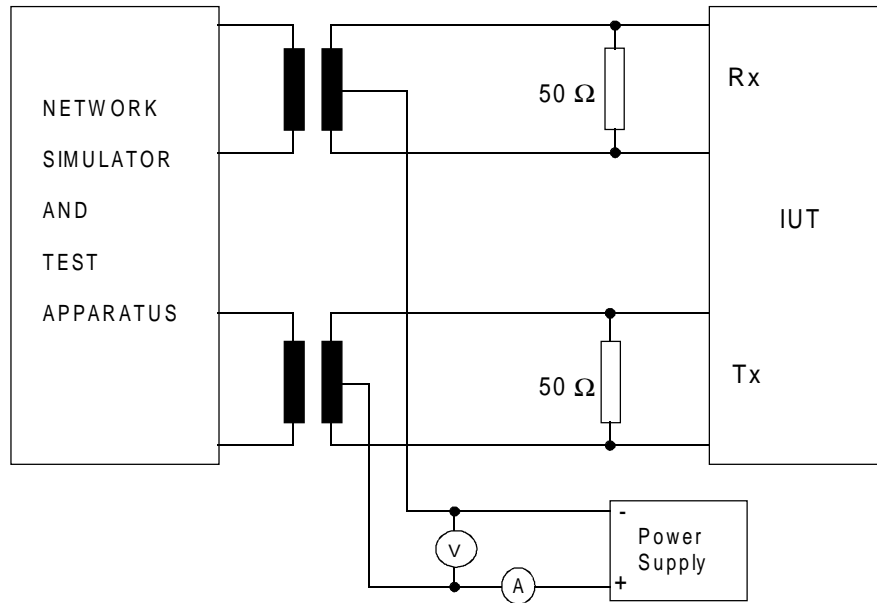

Figure 40: Test configuration

System state: Deactivated (state F3).

Stimulus: Phantom, normal mode PS1 in the voltage range 40 V, +5 %, -40 % (42 V to 24 V).

Monitor: dc voltage and current.

Results: The power drawn ($V \times I$) shall not exceed 100 mW at both extremes of the power source voltage as stated in the stimulus section.

8.1.1.3 Normal power provision (Test C)

Reference: ETS 300 012-1 [8], subclause 10.3.1.1 and 10.4.1.

Purpose: To ensure a DEACTIVATED TE does not draw excessive power from a normal mode, phantom Power Source 1, whilst in local action.

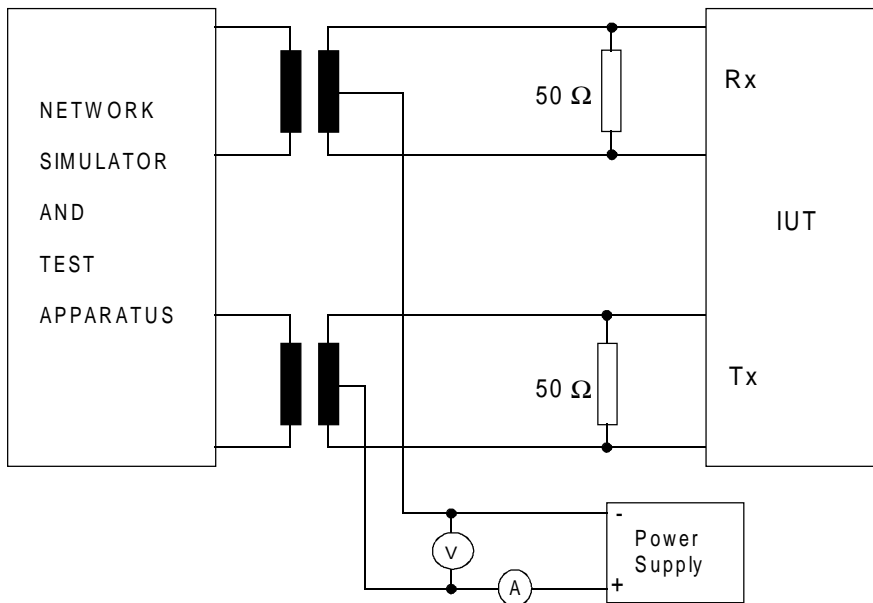

Figure 41: Test configuration

System state: Deactivated (state F3).

Stimulus: Local action. Phantom, normal mode PS1 in the voltage range 40 V, +5 %, -40 % (42 V to 24 V).

Monitor: dc voltage and current.

Results: The power drawn ($V \times I$) shall not exceed 1 W at both extremes of the power source voltage as stated in the stimulus section.

8.1.1.4 Normal power provision (Test D)

Reference: ETS 300 012-1 [8], subclause 10.3.1.1 and 10.4.1.

Purpose: To ensure a LOCALLY POWERED TE using connected detector does not consume excessive power in any state from PS1.

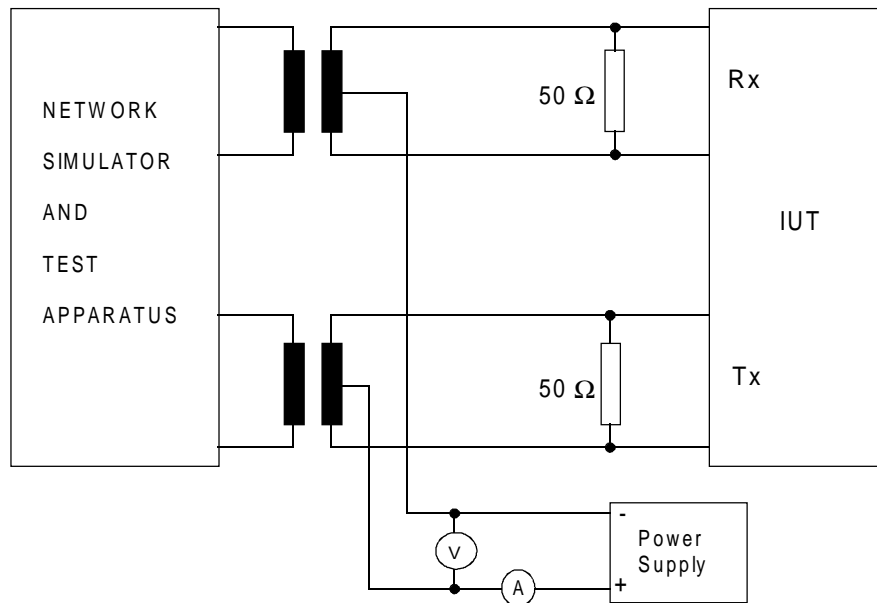

Figure 42: Test configuration

System state: Any state.

Stimulus: Phantom, normal mode PS1 in the voltage range 40 V, +5 %, -40 % (42 V to 24 V).

Monitor: dc voltage and current.

Results: The power consumed by the TE shall not exceed 3 mW at both extremes of the power source voltage as stated in the stimulus section.

8.1.1.5 Normal power provision (Test E)

Reference: ETS 300 012-1 [8], subclause 10.3.1.1 and 10.4.1.

Purpose: To ensure a LOCALLY POWERED TE not using connected detector does not consume power in any state from PS1.

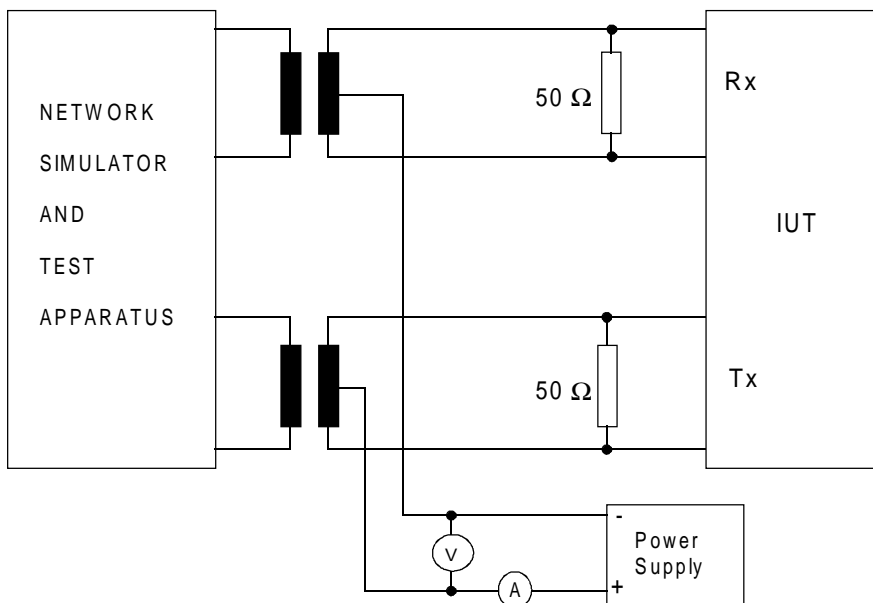

Figure 43: Test configuration

System state: Any state.

Stimulus: Phantom, normal mode PS1 in the voltage range 40 V, +5 %, -40 % (42 V to 24 V).

Monitor: dc voltage and current.

Results: There shall be no power consumed by the TE at both extremes of the power source voltage as stated in the stimulus section (see 4th bullet point of item c) in clause 8).

8.1.2 Restricted power conditions

Reference: ETS 300 012-1 [8], subclause 10.3.1.2 and 10.4.2.

8.1.2.1 Restricted power provision (Test A)

Reference: ETS 300 012-1 [8], subclause 10.3.1.2 and 10.4.2.1.

Purpose: To ensure an ACTIVATED designated TE does not consume excessive power from PS1 (restricted).

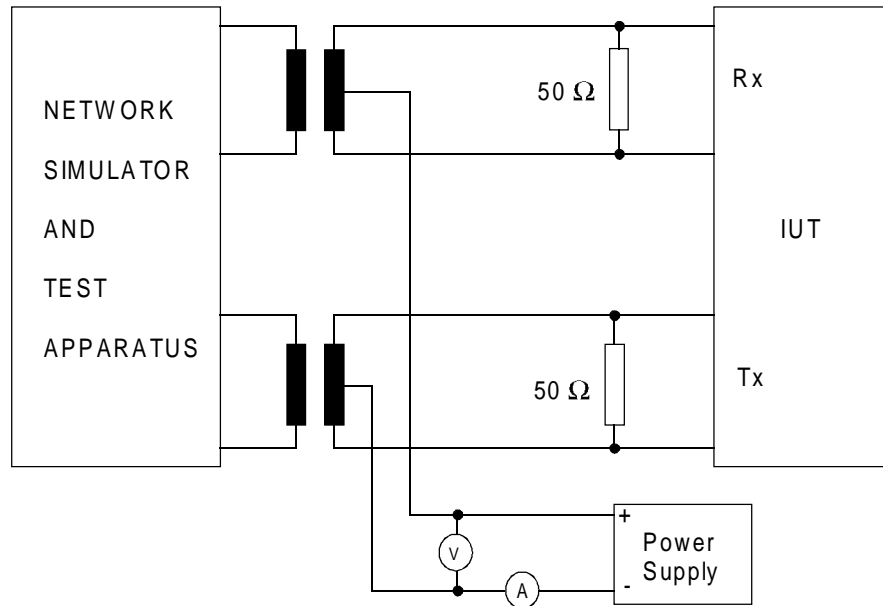

Figure 44: Test configuration

System state: Activated (state F7).

Stimulus: Phantom restricted mode PS1 in the voltage range 40 V, +5 %, -20 % (42 V to 32 V), (voltage reversal).

Monitor: dc voltage and current.

Results: The power consumed by the designated TE shall not exceed 380 mW at both extremes of the power source voltage as stated in the stimulus section.

8.1.2.2 Restricted power provision (Test B)

Reference: ETS 300 012-1 [8], subclause 10.3.1.2 and 10.4.2.1.

Purpose: To ensure a DEACTIVATED designated TE does not consume excessive power from PS1 (restricted).

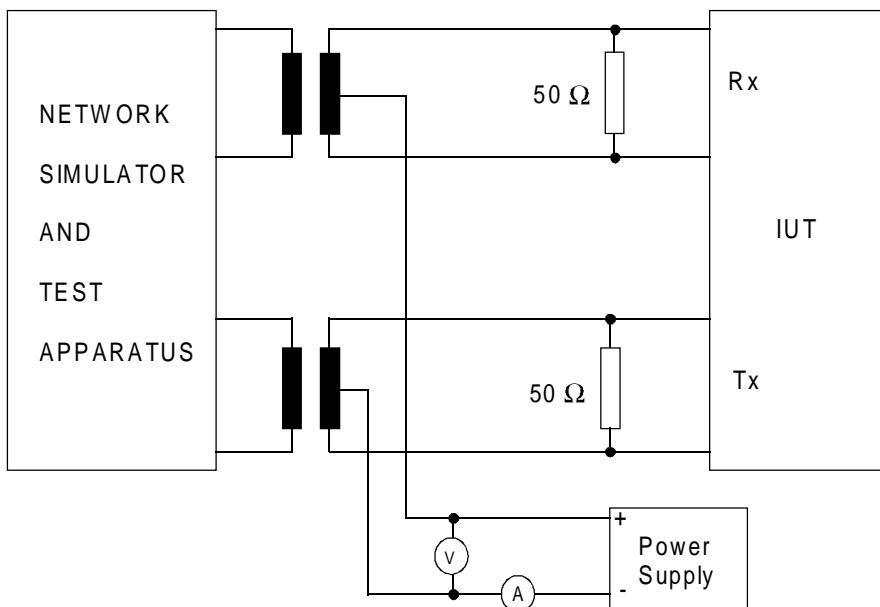

Figure 45: Test configuration

System state: Deactivated (state F3).

Stimulus: Phantom restricted mode PS1 in the voltage range 40 V, +5 %, -20 % (42 V to 32 V), (voltage reversal).

Monitor: dc voltage and current.

Results: The power consumed by the designated TE whilst deactivated shall not exceed 25 mW at both extremes of the power source voltage as stated in the stimulus section.

8.1.2.3 Restricted power provision (Test C)

Reference: ETS 300 012-1 [8], subclause 10.3.1.2 and 10.4.2.1.

Purpose: To ensure a DEACTIVATED designated TE does not consume excessive power from PS1 (restricted) during a local action.

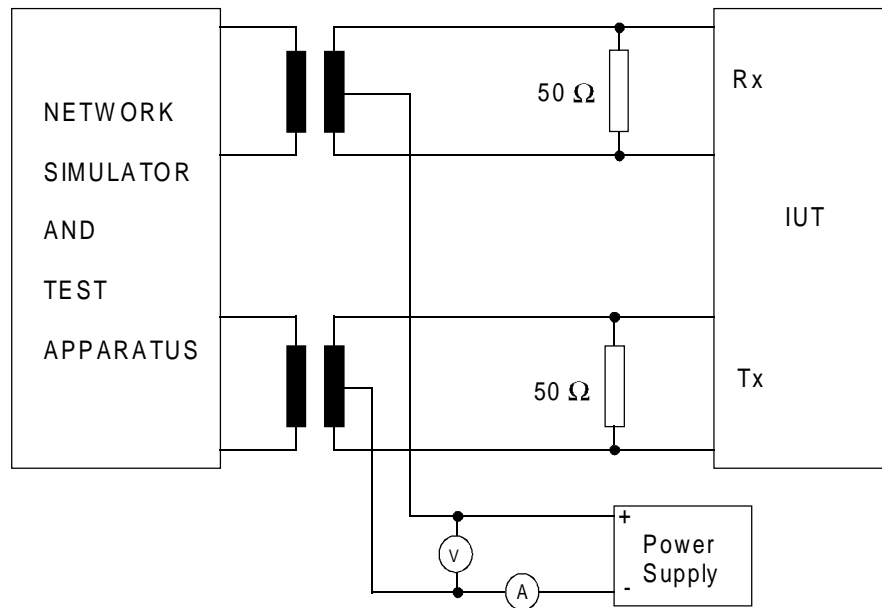

Figure 46: Test configuration

System state: Deactivated (state F3).

Stimulus: Local action. Phantom restricted mode PS1 in the voltage range 40 V, +5 %, -20 % (42 V to 32 V), (voltage reversal).

Monitor: dc voltage and current.

Results: The power consumed by the designated TE shall not exceed 380 mW at both extremes of the power source voltage as stated in the stimulus section.

8.1.2.4 Restricted power provision (Test D)

Reference: ETS 300 012-1 [8], subclause 10.3.1.2 and 10.4.2.1.

Purpose: To ensure that a locally powered TE, in any state, using a connection detector, does not consume excessive power from PS1 (restricted).

NOTE: This requirement also applies to the APS.

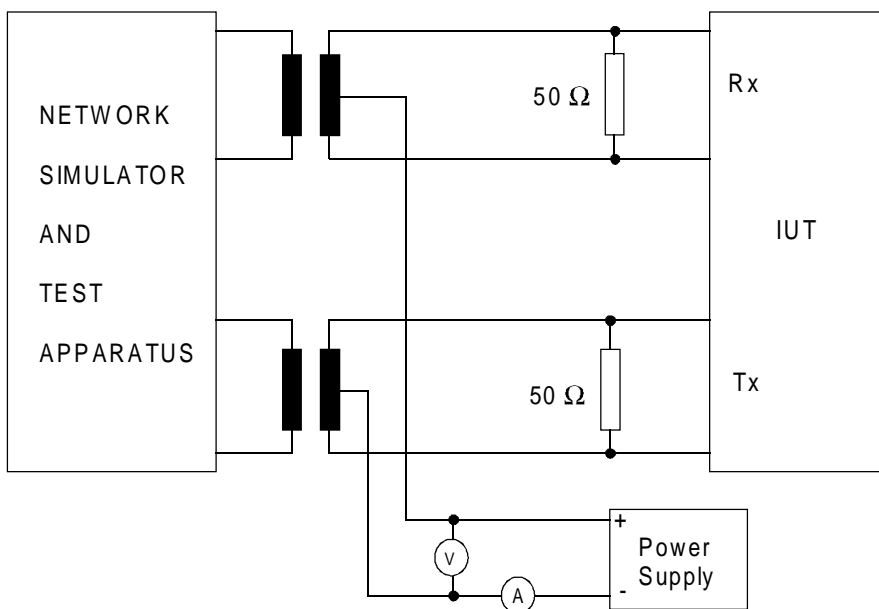

Figure 47: Test configuration

System state: Any state.

Stimulus: Phantom restricted mode PS1 in the voltage range 40 V, +5 %, -20 % (42 V to 32 V), (voltage reversal).

Monitor: dc voltage and current.

Results: The power consumed by the TE shall not exceed 3 mW at both extremes of the power source voltage as stated in the stimulus section.

8.1.2.5 Restricted power provision (Test E)

Reference: ETS 300 012-1 [8], subclause 10.3.1.2 and 10.4.2.1.

Purpose: To ensure a LOCALLY POWERED TE not using connected detector does not consume power in any state from PS1 (restricted).

NOTE: This requirement also applies to the APS.

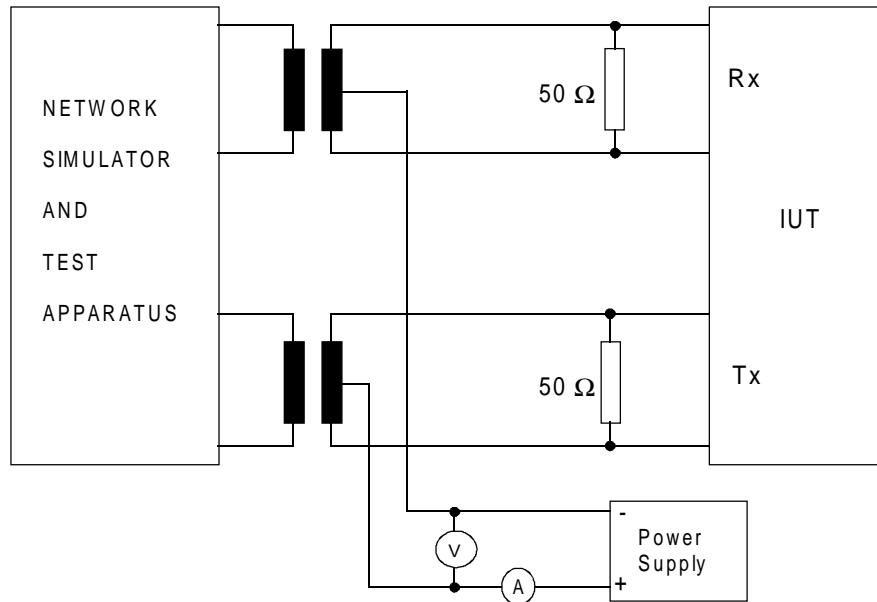

Figure 48: Test configuration

System state: Any state.

Stimulus: Phantom, normal mode PS1 in the voltage range 40 V, +5 %, -40 % (42 V to 32 V).

Monitor: dc voltage and current.

Results: There shall be no power consumed by the TE at both extremes of the power source voltage as stated in the stimulus section (see 4th bullet point in clause 8).

8.1.2.6 Restricted power provision (Test F)

Reference: ETS 300 012-1 [8], subclause 10.3.1.2 and 10.4.2.2.

Purpose: To ensure a non designated TE does not consume excessive power from PS1 (restricted) in any state.

NOTE: This requirement also applies to the APS.

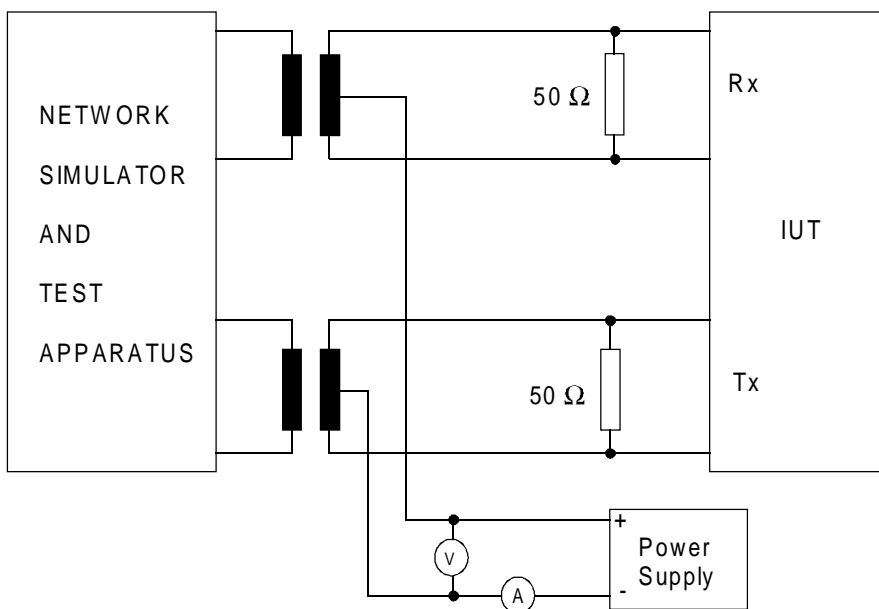

Figure 49: Test configuration

- System state: Inactive (state F1).
- Stimulus: Phantom restricted mode PS1 in the voltage range 40 V, +5 %, -20 % (42 V to 32 V), (voltage reversal).
- Monitor: dc voltage and current.
- Results: There shall be no power consumed by the TE at both extremes of the power voltage as stated in the stimulus section (see 4th bullet point of item c) in clause 8).

8.1.3 Current transient

Reference: ETS 300 012-1 [8], subclause 10.6.

Purpose: To test the rate of change of the current drawn by a TE when the TE is varying its power consumption. This may be caused by changing the state, by some local actions or by some TE typical services.

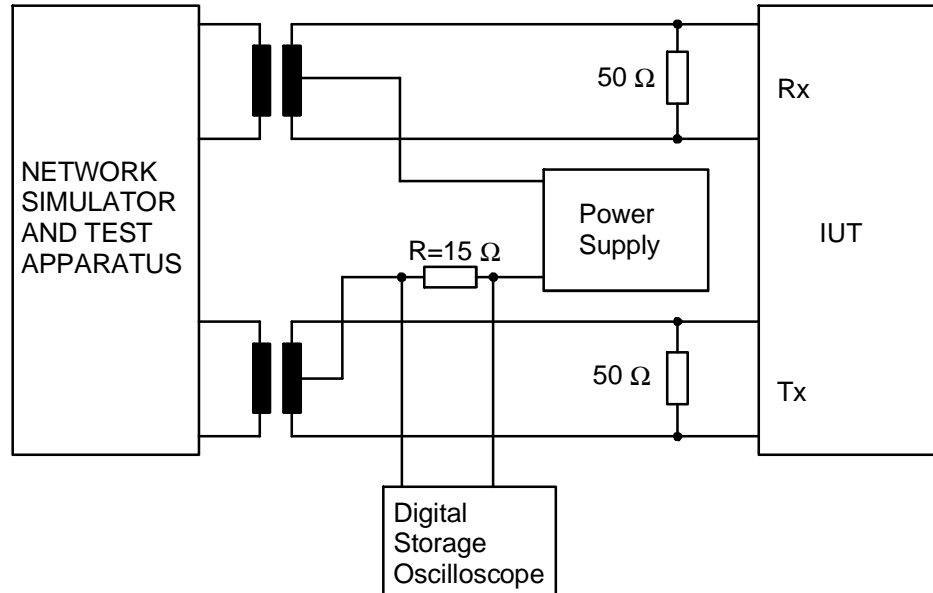

Figure 50: Test configuration

System state: Any state from F3 to F8 in normal and restricted mode as applicable.

Stimulus: It is dependent on the kind of TE how maximum current can be drawn.

Monitor: Current drawn by the TE.

Results: The current transient shall not exceed 5 mA/μs in the specified voltage range. The slope is measured from 10 % to 90 % of the current change.

NOTE: To ensure that the measured current transient is not due to a superimposed noise, only a change of current greater than 1,5 mA should be taken into consideration.

8.1.4 Limitation on power sink during transient conditions

8.1.4.1 Current/time limitation for TE

Reference: ETS 300 012-1 [8], subclause 10.6.1 and 10.6.2.

Purpose: To test the behaviour of current over time when connecting to PS1 in normal and restricted mode.

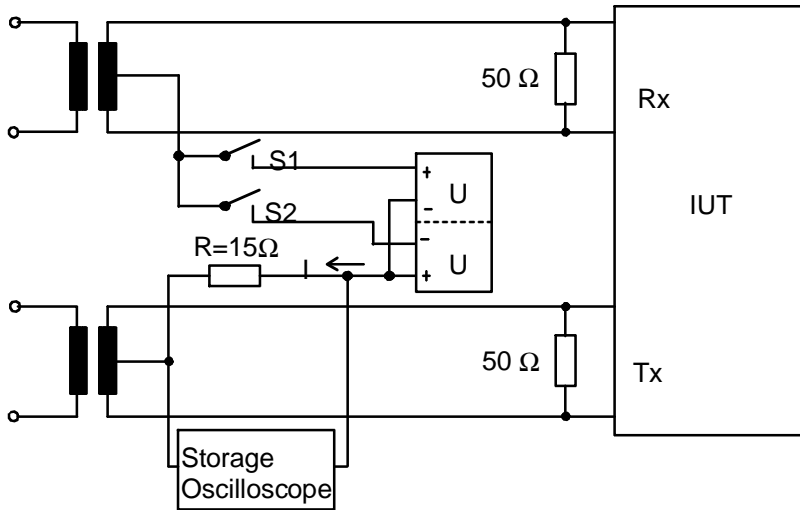

Figure 51: Test configuration

NOTE 1: Ideal switch on condition (rise-time $\rightarrow 0$).

System state: Inactive (state F1) (S1 and S2 are open).

NOTE 2: The internal capacitor of the IUT is discharged.

Stimulus: Phantom supply voltage.

Test 1 - normal mode, S2 is closed, S1 is open;
 test 2 - restricted mode, S2 is open, S1 is closed.

$$U = 40 \text{ V} \quad R = 15 \Omega$$

Monitor: Current I over time.

NOTE 3: The time 0 is defined when the current detected exceeds 4 mA for the first time.

- Results:
- a) Current variation with time shall comply with the mask defined in ETS 300 012-1 [8], figure 20, with the values given in table 10 for normal power conditions and the values given in table 11 for restricted power conditions (time extension to 1 s for test of power consumption in $t > 100 \text{ ms}$).
 - b) For TEs designed to minimize power disturbance (second alternative described in ETS 300 012-1 [8], subclause 10.6.2), the current time shall comply with the mask defined in ETS 300 012-1 [8], figure 25 with the values given in tables 10 and 11 respectively .

8.1.4.2 Current/time limitation for TE when connecting

Reference: ETS 300 012-1 [8], subclauses 10.6.1 and D.6.

Purpose: To test the sink current of a non-designated or locally powered TE from the phantom in restricted mode when connecting to the S-Bus.

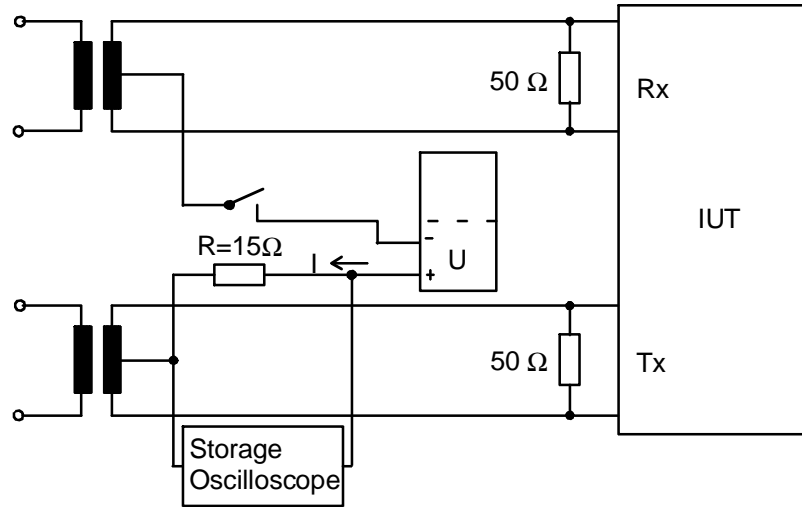

Figure 52: Test configuration

NOTE. Ideal switch on condition (rise-time $\rightarrow 0$).

System state: Inactive (state F1).

Stimulus: Phantom supply voltage. Restricted mode
 $U = -40\text{ V}$ $R = 15\ \Omega$
 The test setup shall be capable to provide a connection to ground. The measurement shall be done in both wires connecting the power supply to the IUT.

Monitor: Current I over time.

Results: Current timing shall comply with the following mask defined in subclause 10.6.1 of ETS 300 012-1 [8].

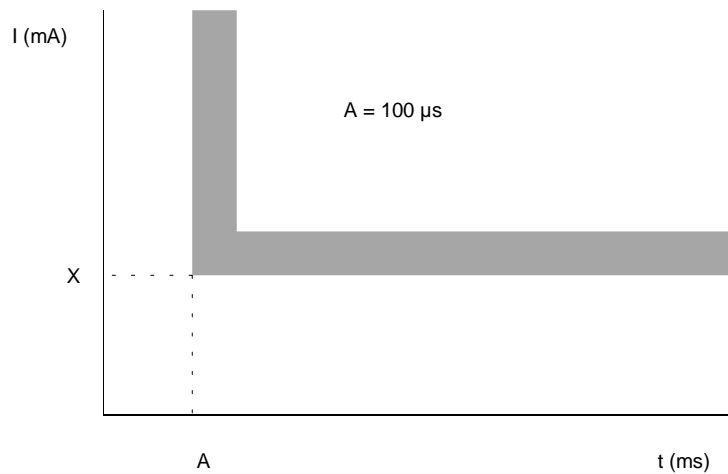

	TE with connection detector	TE without connection detector
X	equivalent to 3 mW	10 μA

8.1.4.3 Behaviour of a TE using a connection detector

Reference: ETS 300 012-1 [8], subclause 10.6.1.

Purpose: To test the connection detector when disconnecting.

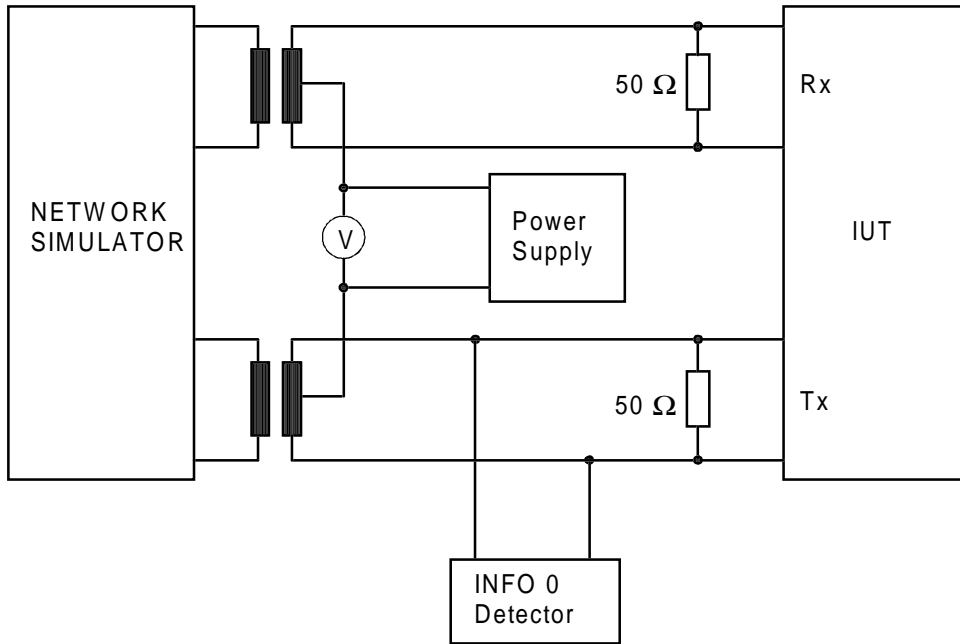
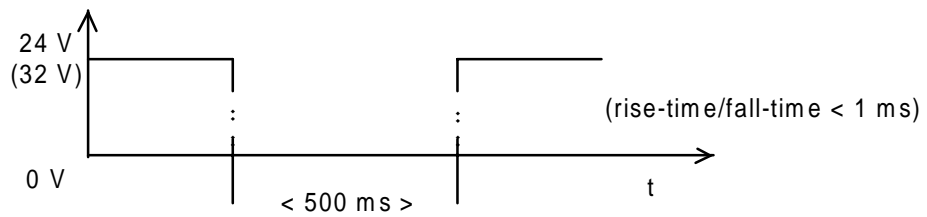

Figure 53: Test configuration

System state: State F4, F6 and F7 in normal and restricted modes.

Stimulus: The PS1 (normal) voltage shall be reduced from 24 V to 0 V and then, after 500 ms at 0 V, shall rise again to 24 V. The rise and fall time shall each be less than 1 ms.

The PS1 (restricted) voltage shall be reduced from 32 V to 0 V and then, after 500 ms at 0 V, shall rise again to 32 V. The rise and fall time shall each be less than 1 ms.



Monitor: TE transmission line.

Results: INFO 0 shall not occur within 1 s after disappearance of the interruption.

8.1.4.4 Power start-up test

8.1.4.4.1 Power start-up test after removal of short-circuit

Reference: ETS 300 012-1 [8], subclause 10.6.4.1.

Purpose: To test the behaviour of TE input voltage over time after removal of short-circuit.

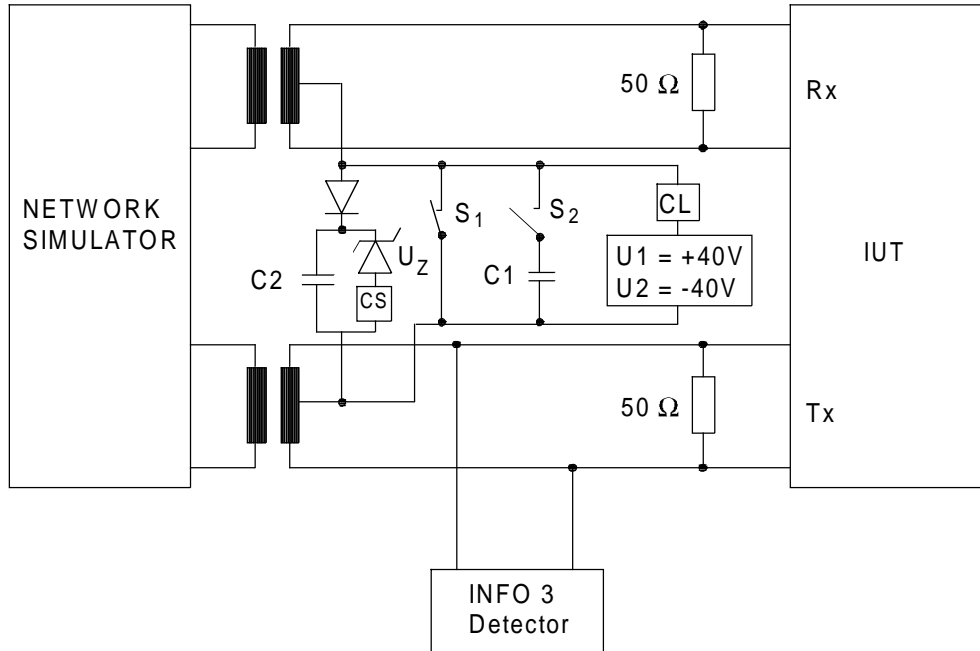

Figure 54: Test configuration

System state: Inactive (state F1).

Stimulus: Removal of short-circuit (open S₁) and network simulator sending INFO 2.

Test 1: Restricted mode.
 Test parameters (see table 12, ETS 300 012-1 [8], subclause 10.6.4.1).

Test 2: Normal mode.
 Test parameters (see table 13, ETS 300 012-1 [8], subclause 10.6.4.1).

Monitor: Transmission of INFO 3 (TE -> Network Simulator).

Results: TE shall transmit INFO 3 within 1 minute after removal of short-circuit.

8.1.4.4.2 Power start-up test at low input voltage

Reference: ETS 300 012-1 [8], subclause 10.6.4.1 and 10.3.1.1.

Purpose: To test the power start-up of a TE when connected to PS1 normal at low voltage.

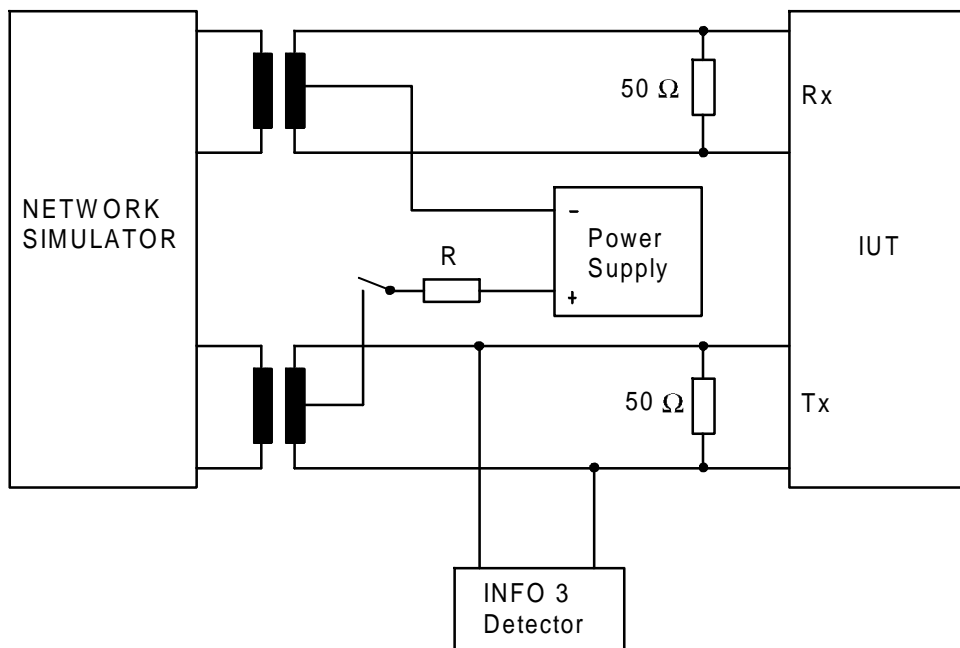

Figure 55: Test configuration

System state: Inactive (state F1).

Stimulus: Phantom supply voltage (normal mode) and INFO 2.

U = 28 V.

R = 70 Ω.

Monitor: Transmitted line signal.

Result: TE shall transmit INFO 3 within 1 minute after the switch-on of the power source.

8.1.4.5 Protection against short-term interruptions

8.1.4.5.1 Normal power

Reference: ETS 300 012-1 [8], subclause 10.6.4.2.

Purpose: To ensure that an IUT does not lose an ongoing communication when the provision of power in normal power mode is interrupted.

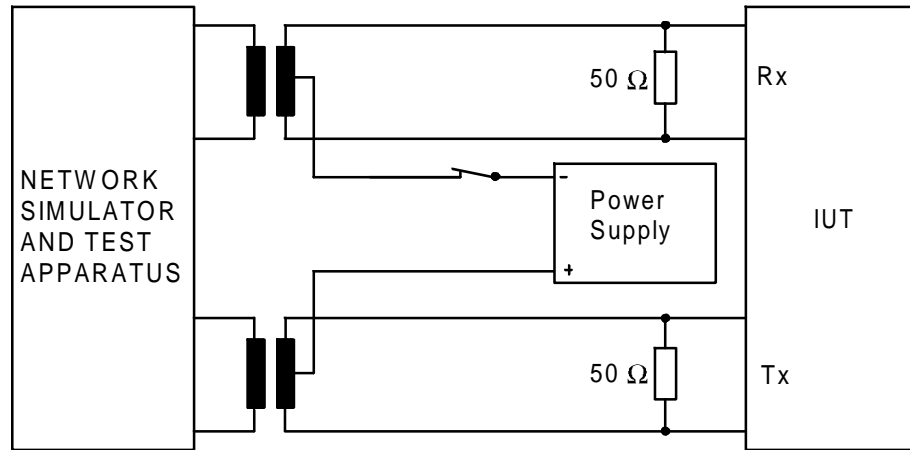

Figure 56: Test configuration

System state: Activated (state F7) with maximum power consumption and communication established.

Stimulus: Normal mode $U = 24\text{ V}$.
PS1 interrupted for 5 ms

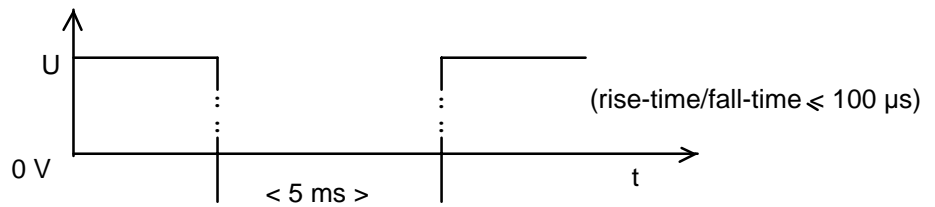

Figure 57: Characteristics of PS1 voltage

Monitor: Ongoing communication.

Results: No loss of ongoing communication within 30 seconds after the application of the interruption.

8.1.4.5.2 Restricted power

Reference: ETS 300 012-1 [8], subclause 10.6.4.2.

Purpose: To ensure that a IUT does not lose an ongoing communication when the provision of power in restricted power mode is interrupted.

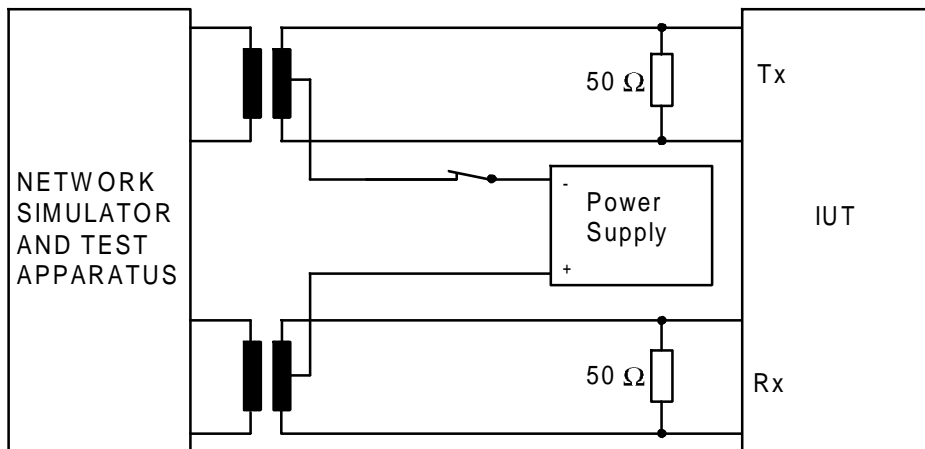

Figure 58: Test configuration

System state: Activated (state F7) with maximum power consumption and communication established.

Stimulus: Normal mode $U = 32\text{ V}$.
PS1 interrupted for 5 ms

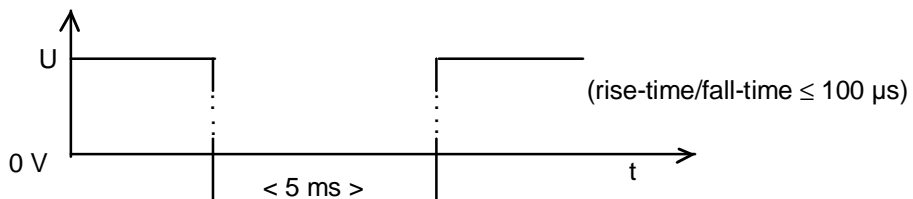

Figure 59: Characteristics of PS1 voltage

Monitor: Ongoing communication.

Results: No loss of ongoing communication within 30 seconds after the application of the interruption.

8.1.4.6 Behaviour at the switch-over

8.1.4.6.1 Normal power

Reference: ETS 300 012-1 [8], subclause 10.6.4.3.

Purpose: To check the reaction of an IUT under normal power condition, when the mode changes from normal to restricted mode.

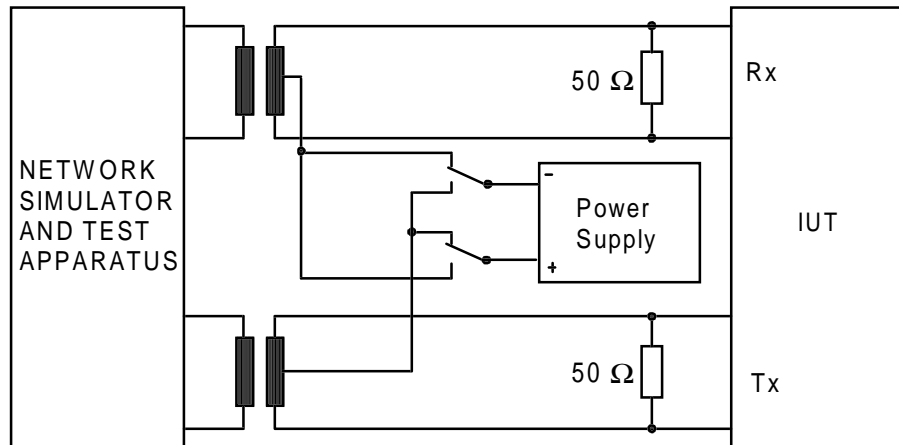

Figure 60: Test configuration

System state: Activated (state F7) with maximum power consumption.

Stimulus: Change from +32 V without current limitation to -40 V with 11 mA current limitation. Changeover period shall not exceed 5 ms.

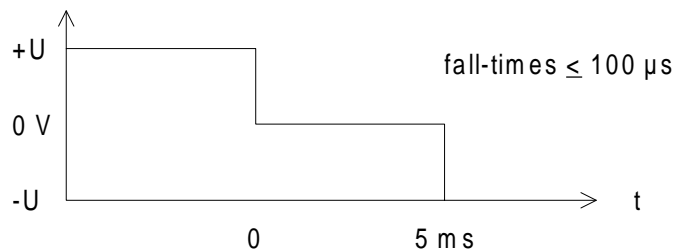

Figure 61: Characteristics of PS1 voltage

Monitor: Ongoing communication.

Results: No loss of the ongoing communication within 30 seconds after switchover.

8.1.4.6.2 Restricted power

Reference: ETS 300 012-1 [8], subclause 10.6.4.3.

Purpose: To check the reaction of power consumption of an IUT after change from restricted to normal mode.

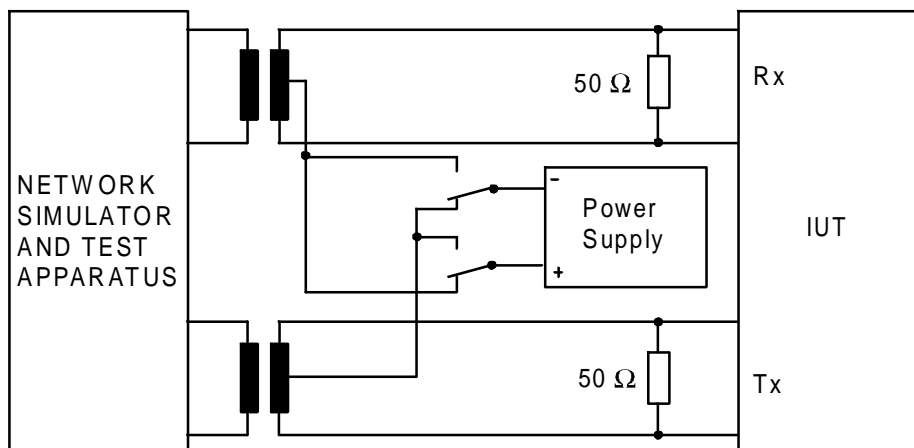

Figure 62: Test configuration

System state: Activated (state F7) with maximum power consumption.

Stimulus: Change from restricted mode ($U = -32\text{ V}$) to normal mode ($U = +32\text{ V}$).

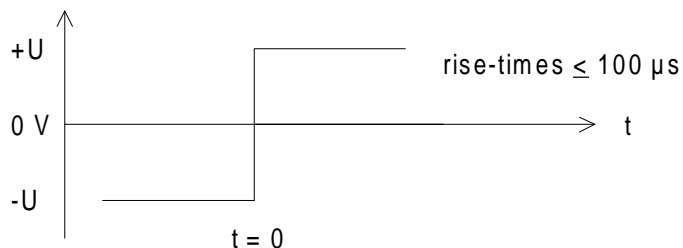

Figure 63: Characteristics of PS1 voltage

Monitor: dc-voltage and dc-current.

Results: The IUT shall not draw more than 380 mW from $0 < t < 500\text{ ms}$.

8.1.4.7 dc unbalance of TEs using power sink 1

Reference: ETS 300 012-1 [8], subclause 10.7.1.2.

Purpose: To test the dc unbalance of the receiver and transmitter circuit.

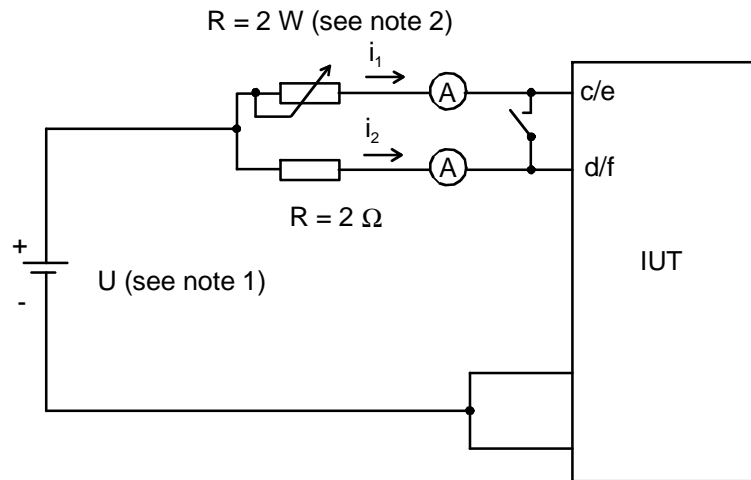

NOTE 1: The polarity of U (and i) is represented for testing the transmitter side (c and d wires). For testing the receiver (e and f wires) the polarity shall be reversed.

NOTE 2: Before connecting IUT, calibration to get the same current in both wires shall be done.

Figure 64: Test configuration

System state: Deactivated (state F3).

Monitor: The currents i_1 and i_2 at the receiver and transmitter sides.

Results: The direct current unbalance (X) shall be less than 3 %.

$$X = \frac{|i_1 - i_2|}{i_1 + i_2} \times 100 \%$$

8.1.4.8 Effect of current unbalance

Reference: ETS 300 012-1 [8], subclause 10.7.2.

Purpose: To test the impedance of the receiver and transmitter when a direct current unbalance is applied.

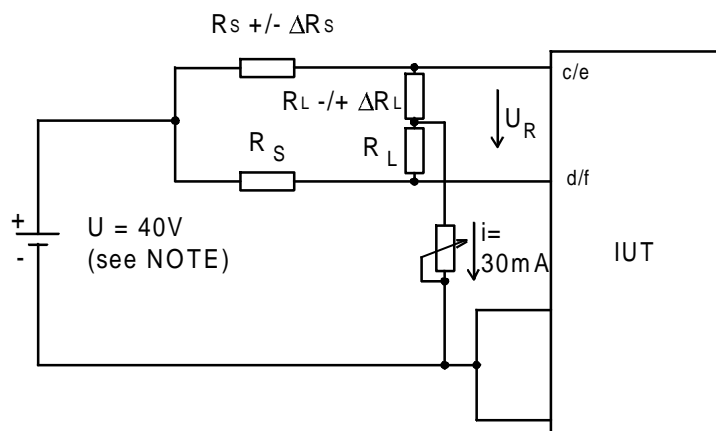

NOTE: The polarity of U is represented for testing the transmitter side (c and d wires). For testing the receiver (e and f wires) the polarity shall be reversed.

Figure 65: Test configuration 1

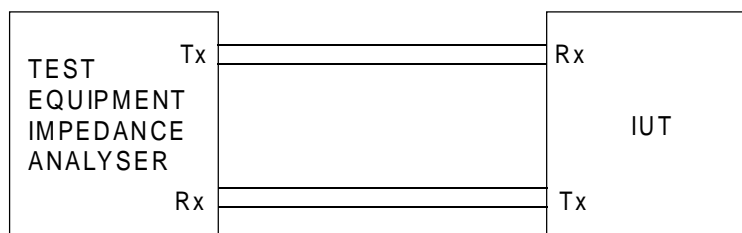

Figure 66: Test configuration 2

System state: Deactivated (state F3).

Stimulus:

Test configuration 1 : PS1 normal with test circuit applied with both polarities at the receiver and transmitter side.

Test configuration 2: Sinusoidal voltage of 100 mV rms, in the frequency range of 2 kHz to 20 kHz, superimposed with the dc voltage U_R as measured in test configuration 1.

Monitor: dc voltage at c to d and e to f at both polarities. For both transmitter and receiver, the greater value is taken for the next step as specified in test configuration 2.

Impedance.

Results: The impedance shall exceed the impedance template as given in ETS 300 012-1 [8], figure 12 in the range from 2 kHz to 20 kHz.

8.2 Power source 2 - optional third pair

Reference: ETS 300 012-1 [8], subclause 10.3.2.

Purpose: To ensure a TE does not draw excessive power from a Power Source 2 whilst in any state.

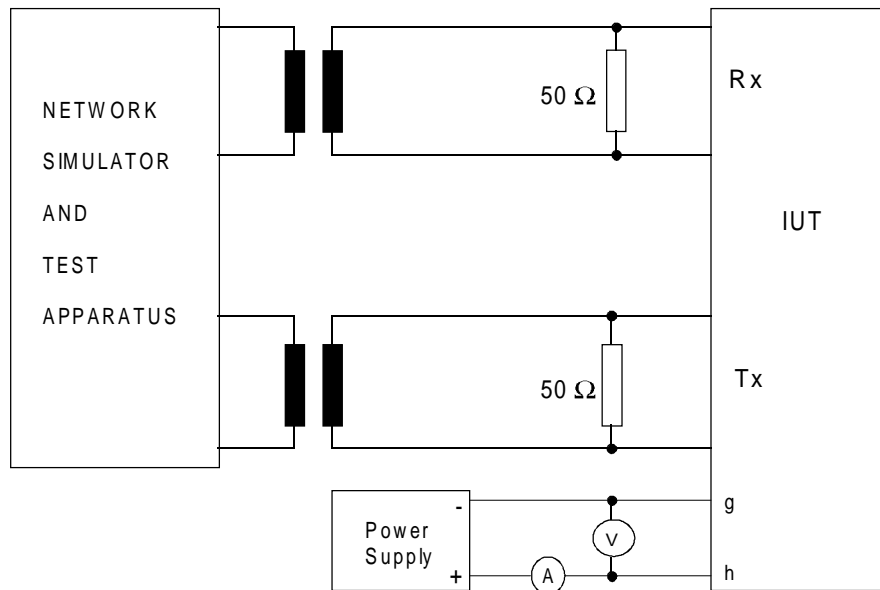

Figure 67: Test configuration

System state: Any state.

Stimulus: PS2 in the voltage range 40 V, +5 % -20 % (42 V to 32 V).

Phantom restricted mode PS1 in the voltage range 40 V, +5 %, -20 % (42 V to 32 V), with an additional longitudinal voltage of +50 V and -50 V applied.

Monitor: dc voltage and current.

Results: The power drawn ($V \times I$) shall not exceed N Watt at both extremes of the power source voltage as stated in the stimulus section.

- a) normal power conditions: N = 7 W
- b) restricted power conditions: N = 2 W

8.3 Galvanic isolation

Reference: ETS 300 012-1 [8], subclause 10.5.

Purpose: To ensure the TE does not draw excessive earth current from a phantom Power Source 1.

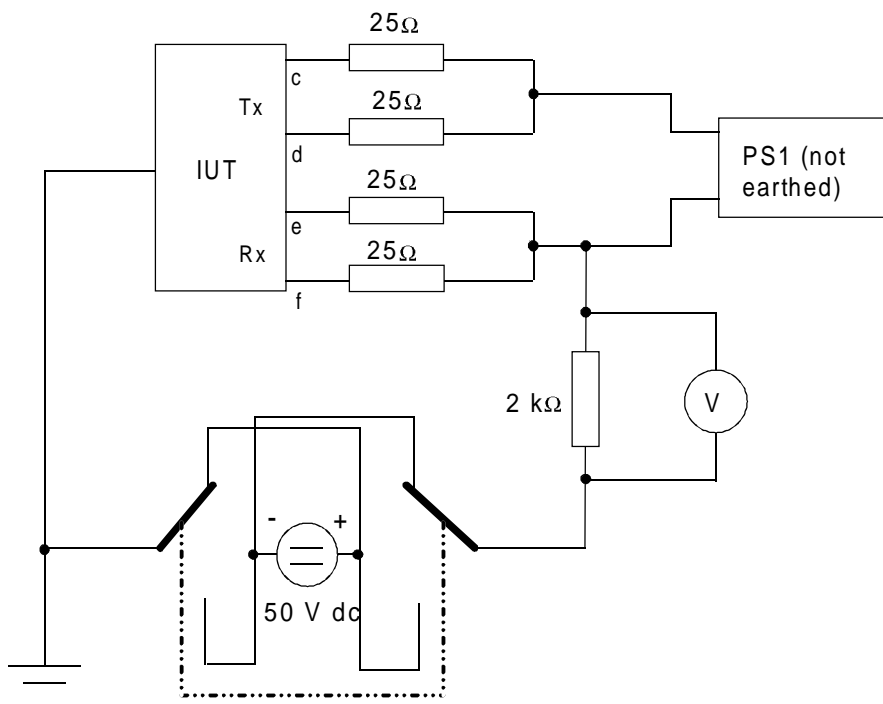

Figure 68: Test configuration

System state: Inactive (F3).

Stimulus: Phantom, normal mode PS1 in the voltage range 40 V, +5 % -40 % (42 V to 24 V), with an additional longitudinal voltage of +50 V and -50 V applied.
 Phantom restricted mode PS1 in the voltage range 40 V, +5 %, -20 % (42 V to 32 V), with an additional longitudinal voltage of +50 V and -50 V applied.

Monitor: Current flowing between PS1 and the IUT's connection to earth.

Results: The earth current drawn shall not exceed 100 μ A at both extremes of the power source voltage as stated in the stimulus section.

Annex A (normative): Connection cords and general testing requirements

A.1 Connection cords

In the case where a PTNX does not use a connection cord at the T reference point, the location of interface I_A shall be declared by the PTNX supplier.

However, TEs using detachable connecting cords and designated for connection with a "standard ISDN basic access cord" shall meet the specified electrical characteristics in both cases as follows:

- a) with a specific cord provided with the IUT;
- b) with a reference cord conforming to the requirements as described in table A.1:

Table A.1: Electrical characteristics of the ISDN reference cord

Parameter	C	Z	CL	R	D
Value	350 pF	> 75 Ω	> 60 dB	3 Ω	< 0,5 %
Tolerance	+ 0 % - 10 %	-	-	+ 0 % - 10 %	-
<p>C: capacitance of pairs for transmit and receive functions; Z: characteristic impedance of pairs used for transmit and receive functions at 96 kHz; CL: crosstalk loss at 96 kHz between any pair and a pair used for transmit and receive functions with terminations at 100 Ω; R: resistance of an individual conductor; D: difference of the ohmic resistance in each pair (percentage of the ohmic resistance).</p> <p>NOTE: The total length of the cord depends on the parameters shown above. Nevertheless, this length should preferably be 7 m and in any case shall be less than 10 m.</p>					

A.2 General testing requirements

The test configurations given do not imply a specific realization of test equipment or arrangement or the use of specific test devices for conformance testing. However, any test configuration used shall provide those test conditions specified under "system state", "stimulus" and "monitor" for each individual test (the measurement arrangements and the equipment suggested are only for example purposes).

In the case of a multi-access item under test supporting interface I_A, unless otherwise stated, only one access at a time shall receive the stimulus. All other accesses shall receive "no signal".

For conformance test purposes it is requested that a complete loopback 4 is provided by an IUT (see ETS 300 012-1 [8], annex C, table C.2) and also a test pattern of INFO 3 frames with the B1 and B2 channels set to binary ZERO.

IUT suppliers shall provide information on how IUT primitive exchanges can be detected i.e. primitives activate, deactivate, management primitives between layer 1 and higher layers.

Unless otherwise stated the line termination resistors for both NT and TE side are considered inside the test equipment.

History

Document history	
April 1992	First Edition
November 1996	Public Enquiry PE 118: 1996-11-18 to 1997-03-14