



**E**UROPEAN  
**T**ELECOMMUNICATION  
**S**TANDARD

**FINAL DRAFT**  
pr **ETS 300 011-1**

December 1997

Second Edition

---

Source: TM

Reference: RE/TM-03037-1

ICS: 33.020

**Key words:** ISDN, layer 1, primary, rate, UNI, transmission

**Integrated Services Digital Network (ISDN);  
Primary rate User Network Interface (UNI);  
Part 1: Layer 1 specification**

**ETSI**

European Telecommunications Standards Institute

**ETSI Secretariat**

**Postal address:** F-06921 Sophia Antipolis CEDEX - FRANCE

**Office address:** 650 Route des Lucioles - Sophia Antipolis - Valbonne - FRANCE

**X.400:** c=fr, a=atlas, p=etsi, s=secretariat - **Internet:** secretariat@etsi.fr

Tel.: +33 4 92 94 42 00 - Fax: +33 4 93 65 47 16

---

**Copyright Notification:** No part may be reproduced except as authorized by written permission. The copyright and the foregoing restriction extend to reproduction in all media.

© European Telecommunications Standards Institute 1997. All rights reserved.



## Contents

Foreword .....		7
1	Scope .....	9
2	Normative references .....	9
3	Definitions, symbols and abbreviations .....	10
3.1	Definitions .....	10
3.2	Symbols .....	12
3.3	Abbreviations .....	12
4	Type of configuration .....	12
4.1	Point-to-point .....	12
4.2	Location of interface .....	13
4.3	Interface wiring .....	13
4.4	Interface connector .....	13
5	Functional characteristics .....	14
5.1	Summary of functions (layer 1) .....	14
5.2	Interchange circuits .....	15
5.3	Activation/deactivation .....	15
5.4	Definition of primitives .....	17
5.5	Frame structure .....	17
5.5.1	Number of bits per time slot .....	17
5.5.2	Number of timeslots per frame .....	17
5.5.3	Assignments of bits in time slot 0 .....	17
5.5.4	Description of the CRC-4 procedure in bit 1 of the frame .....	18
5.5.4.1	Allocation of bit 1 to 8 of the frame for a complete multiframe .....	18
5.5.4.2	Sub-MultiFrame (SMF) .....	18
5.5.4.3	Use of bit 1 in 2 048 kbit/s CRC-4 multiframe .....	19
5.5.5	Cyclic Redundancy Check (CRC) .....	19
5.5.5.1	Multiplication/division process .....	19
5.5.5.2	Encoding procedure .....	19
5.5.5.3	Decoding procedure .....	19
5.6	Bit sequence independence .....	19
5.7	Line code .....	19
5.8	Timing considerations .....	20
6	Interface procedure .....	20
6.1	Definition of signals at the interface .....	20
6.2	Definitions of state tables at network and user sides .....	21
6.3	Layer 1 states on the user side of the interface .....	22
6.4	Layer 1 states at the network side of the interface .....	23
6.5	State tables .....	24
6.6	Allocation of time slots .....	26
6.7	Interframe (layer 2) time fill .....	26
6.8	Frame alignment and CRC-4 procedures .....	26
6.8.1	Loss and recovery of basic frame alignment .....	26
6.8.1.1	Loss of basic frame alignment .....	26
6.8.1.2	Strategy for basic frame alignment recovery .....	26
6.8.2	CRC multiframe alignment using information in bit 1 of the basic frame .....	26
6.8.3	CRC bit monitoring .....	27
6.8.3.1	Monitoring procedure .....	27
6.8.3.2	Monitoring for false basic frame alignment .....	27
6.8.3.3	Error performance monitoring using CRC-4 .....	28

7	Maintenance at the interface .....	28
7.1	Definitions of maintenance signals.....	29
7.2	Use of CRC procedure.....	29
7.2.1	Introduction .....	29
7.2.2	Localization of the CRC functions from the user point of view .....	29
7.2.2.1	No CRC processing in the transmission link.....	29
7.2.2.2	CRC processing in the digital transmission link.....	30
7.3	Maintenance functions .....	30
7.3.1	General requirements.....	30
7.3.2	Maintenance functions on the user side .....	31
7.3.2.1	Anomalies and defect detection.....	31
7.3.2.2	Detection of defect indication signals.....	31
7.3.2.3	Consequent actions .....	31
7.3.3	Maintenance functions on the network side.....	31
7.3.3.1	Defect detection .....	32
7.3.3.2	Detection of defect indication signals.....	32
7.3.3.3	Consequent actions .....	32
8	Electrical characteristics .....	33
8.1	Type of interface.....	33
8.2	Specifications at the output ports .....	33
8.2.1	Bit rate .....	33
8.2.2	Waveform shape .....	33
8.2.3	Return loss at the output port .....	35
8.2.4	Impedance towards ground of the output port.....	35
8.3	Specification at the input ports .....	35
8.3.1	Receiver sensitivity .....	35
8.3.2	Return loss at the input port.....	35
8.3.3	Input port immunity against reflections .....	35
8.3.4	Tolerable longitudinal voltage .....	36
8.3.5	Impedance towards ground of the input port .....	36
8.4	Jitter.....	36
8.4.1	General considerations.....	36
8.4.2	Minimum tolerance to jitter and wander at TE inputs .....	37
8.4.2.1	Tolerable input jitter when connected at T, S or S/T reference point .....	37
8.4.2.2	Tolerable input jitter when connected to leased lines .....	38
8.4.3	TE and NT2 output jitter at interface I <sub>A</sub> .....	38
8.4.3.1	TE and NT2 with only one UNI.....	38
8.4.3.2	TE and NT2 with more than one UNI to the same public ISDN.....	38
8.4.3.3	TE and NT2 designed for interconnection via leased lines.....	39
8.4.4	Minimum tolerance to jitter and wander at NT inputs .....	39
8.4.4.1	Tolerable input jitter at T reference point .....	39
8.4.4.2	Tolerable input jitter at leased lines input.....	40
9	Power feeding.....	40
9.1	Provision of power.....	40
9.2	Power available at the NT .....	40
9.3	Feeding voltage.....	41
9.4	Safety requirements .....	41
	Annex A (normative): Application of ETS 300 011-1 to the S reference point.....	42
A.1	Scope.....	42
A.2	Requirements .....	42
A.2.1	Timing considerations .....	42
A.2.2	Jitter, general considerations .....	42
A.2.3	Frame alignment and CRC-4 procedures .....	42
A.3	Interface wiring .....	43

A.4	Loopbacks required at S reference point .....	43
Annex B (normative):	Characteristics of loopbacks .....	44
B.1	Introduction.....	44
B.2	Characteristics of loopback at the network side.....	44
B.3	Characteristics of loopbacks for primary rate customer installations.....	45
Annex C (informative):	Overview of technical changes to edition 1 .....	46
Annex D (informative):	Bibliography.....	47
History.....		48

Blank page

## Foreword

This final draft second edition European Telecommunication Standard (ETS) was produced by the Transmission and Multiplexing (TM) Technical Committee of the European Telecommunications Standards Institute (ETSI) and is now submitted for the voting phase of the ETSI standard approval procedure.

This ETS aims to meet urgent requirements of network operators and equipment manufacturers who are designing equipment to operate with an Integrated Services Digital Network (ISDN) primary rate access User Network Interface (UNI).

This ETS is based upon CCITT Recommendation I.431 and provides modifications and further requirements to that document. It also is affected by CCITT Recommendations G.703, G.704 and G.706, and modifications to these CCITT Recommendations are provided within this ETS.

This ETS also takes into account requirements contained in ECMA Standard 104: "Physical layer at the primary rate access interface between data processing equipment and private switching networks (1985)", which are given in annex A.

This ETS consists of 3 parts as follows:

**Part 1: "Layer 1 specification";**

Part 2: "Conformance test specification for interface I<sub>A</sub> and I<sub>B</sub>";

Part 3: "Implementation Conformance Statement (ICS) and Implementation eXtra Information for Testing (IXIT) proforma specification for Interface I<sub>A</sub> and I<sub>B</sub>".

<b>Proposed transposition dates</b>	
Date of latest announcement of this ETS (doa):	3 months after ETSI publication
Date of latest publication of new National Standard or endorsement of this ETS (dop/e):	6 months after doa
Date of withdrawal of any conflicting National Standard (dow):	6 months after doa

Blank page



## 1 Scope

This second edition European Telecommunication Standard (ETS) specifies requirements and test principles for the ISDN 2 048 kbit/s primary rate UNI including the physical, electrical and functional characteristics and the information exchange with higher layers. Compliance with this ETS ensures that, with regard to layer 1 interface aspects, equipment for use with ISDN primary rate access is portable within countries that adhere to this ETS and, furthermore, that interworking with higher layer protocols for ISDN is supported.

This ETS is applicable to equipment having interface I<sub>A</sub> or I<sub>B</sub> for the connection to the ISDN primary rate UNI intended to be installed on customers' premises. In accordance with CCITT Recommendation I.411 [1], this ETS is to be applied to interfaces at reference points S, T and S/T (coincident S and T) of the ISDN reference configuration.

This ETS is applicable for ISDN channel arrangements as defined in CCITT Recommendation I.412 [2], as far as the primary rate at 2 048 kbit/s is concerned.

Annex A specifies additional requirements for interfaces at reference point S.

This ETS does not specify:

- safety requirements;
- interface or equipment overvoltage protection requirements;
- immunity requirements against electromagnetic interferences;
- emission limitation requirements.

## 2 Normative references

This ETS incorporates, by dated or undated reference, provisions from other publications. These normative references are cited at the appropriate places in the text and the publications are listed hereafter. For dated references subsequent amendments to, or revisions of, any of these publications applies to this ETS only when incorporated in it by amendments or revision. For undated references the latest edition of the publication referred to applies.

- |     |  |
|-----|--|
| [1] | CCITT Recommendation I.411 (1993): "ISDN user-network interfaces - Reference configurations".  |
| [2] | CCITT Recommendation I.412 (1988): "ISDN user-network interfaces- Interface structures and access capabilities".   |
| [3] | CCITT Recommendation O.151 (1992): "Error performance measuring equipment operating at the primary rate and above".  |
| [4] | EN 60950 (1992): "Safety of information technology equipment including electrically operated business machines".   |
| [5] | EN 60603-7 (1993): "Connectors for frequencies below 3 MHz for use with printed boards - Part 7: Detail specification for connectors, 8-way, including fixed and free connectors with common mating features". |
| [6] | EN 50082-1 (1992): "Electromagnetic compatibility - Generic immunity standard - Part 1: Residential, commercial and light industry".   |
| [7] | CCITT Recommendation O.162 (1992): "Equipment to perform in-service monitoring on 2048, 8448, 34 368 and 139 264 kbit/s signals".  |
| [8] | ITU-T Recommendation M.20: "Maintenance philosophy for telecommunication networks".  |
| [9] | ETR 001: "Integrated Services Digital Network (ISDN); Customer access maintenance".  |

- [10] ETS 300 046-2 (1992): "Integrated Services Digital Network (ISDN); Primary rate access - safety and protection Part 2 : Interface I<sub>A</sub> - safety".
- [11] ETS 300 046-3 (1992): "Integrated Services Digital Network (ISDN); Primary rate access - safety and protection, Part 3: Interface I<sub>A</sub> - protection".
- [12] ETS 300 046-4 (1992): "Integrated Services Digital Network (ISDN); Primary rate access - safety and protection, Part 4: Interface I<sub>B</sub> - safety".
- [13] ETS 300 046-5 (1992): "Integrated Services Digital Network (ISDN); Primary rate access - safety and protection, Part 5: Interface I<sub>B</sub> - protection".
- [14] ETS 300 125 (1991): "Integrated Services Digital Network (ISDN); User-network interface data link layer specification Application of CCITT Recommendations Q.920/I.440 and Q.921/I.441".
- [15] ETS 300 166 (1993): "Transmission and Multiplexing (TM); Physical and electrical characteristics of hierarchical digital interfaces for equipment using the 2048 kbit/s -based plesiochronous or synchronous digital hierarchies".
- [16] ETS 300 233 (1994): "Integrated Services Digital Network (ISDN); Access digital section for ISDN primary rate".
- [17] ETS 300 247 (1995): "Business Telecommunications (BT); Open Network Provision (ONP) technical requirements; 2 048 kbit/s digital unstructured leased line (D2048U) Connection characteristics".
- [18] ETS 300 419 (1995): "Business Telecommunications (BTC); 2 048 kbit/s digital structured leased lines (D2048S); Connection characteristics".
- [19] CCITT Recommendation X.200 (1994): "Information technology - Open Systems Interconnection - Basic reference model: The basic model".

### 3 Definitions, symbols and abbreviations

#### 3.1 Definitions

For the purposes of this ETS, the following definitions apply:

**Alternate Mark Inversion (AMI):** Is a code where ONEs are represented by alternate positive and negative pulses, and ZEROs by spaces.

**High-Density Bipolar 3 (HDB3):** Is a modified AMI code. An exception occurs for blocks of 4 successive ZEROs. Each block of 4 successive ZEROs is replaced by OOOV or BOOV where B represents an inserted pulse conforming to the AMI and V represents an AMI violation. The choice of OOOV or BOOV is made so that the number of B pulses between consecutive V pulses is odd. In other words, successive V pulses are of alternate polarity so that no direct current (dc) component is introduced.

**interface I<sub>A</sub>:** User side of the ISDN UNI for the primary rate access.

**interface I<sub>B</sub>:** Network side of the ISDN UNI for the primary rate access.

**network side:** NT1, LT and ET functional groups in case of an interface at the T reference point; or relevant parts of the NT2 functional group in case of an interface at the S reference point.

**network option 1:** The digital link between interface at the T and V reference point does not provide a CRC-4 processing, i.e. the CRC-4 is terminated in the TE and the ET. This digital link is called to be "without CRC processing" (see subclause 7.2.2.2).

NOTE 1: This option is not provided by the public ISDN at the T reference point. However it might be used for Private Telecommunications Network Exchange (PTNX) interconnection using unstructured 2 048 kbit/s leased lines.

**network option 2:** The digital link between interface at the T and V reference point provides CRC-4 processing in the NT1 and the ET according ETR 001 [9]. Therefore the combinations of CRC-4 error information and Remote Alarm Indication (RAI) indicate the fault condition; FC1 or FC4 (see subclause 7.2.2.1).

NOTE 2: Option 3 of CCITT Recommendation I.604 with CRC-4 processing in NT1, LT and ET is not relevant for this ETS.

**Network Termination (NT):** An equipment providing interface  $I_B$ .

NOTE 3: This term is used in this ETS to indicate network-terminating aspects of NT1 and NT2 functional groups where these have an  $I_B$  interface.

**Network Termination Type 1 (NT1):** This functional group includes functions broadly equivalent to layer 1 (physical) of the Open System Interconnection (OSI) reference model. These functions are associated with the proper physical and electromagnetic termination of the network. NT1 functions are:

- line transmission termination;
- layer 1 maintenance functions and performance monitoring;
- timing;
- layer 1 multiplexing;
- interface termination.

**Network Termination Type 2 (NT2):** This functional group includes functions broadly equivalent to layer 1 and higher layers of the CCITT Recommendation X.200 [19] reference model. Private Telecommunication Network Exchanges (PTNXs), local area networks and terminal controllers are examples of equipment or combinations of equipment that provide NT2 functions. NT2 functions include:

- layer 2 and layer 3 protocol handling;
- layer 2 and layer 3 multiplexing;
- switching;
- concentration;
- maintenance functions;
- interface termination and other layer 1 functions.

**Private Telecommunication Network Exchange (PTNX):** A nodal identity in a private telecommunication network which provides autonomous and automatic switching and call handling functions used for the provision of telecommunication services which are based on the definitions for those of the public ISDN.

**Private Network Termination (PNT):** A remote unit of equipment which terminates a transmission system employed between the PTNX and the interface  $I_B$  and the S reference point.

**Terminal Adapter (TA):** An equipment with interface  $I_A$  and one or more auxiliary interfaces that allow non-ISDN terminals to be served by an ISDN UNI.

**Terminal Equipment (TE):** An equipment providing an interface  $I_A$ .

NOTE 4: This term is used in this ETS to indicate terminal-terminating layer 1 aspects of TE1, TA and NT2 functional groups, where these have an  $I_A$  interface.

NOTE 5: In annex A, this definition applies with the exception that the NT2 functional grouping is not covered.

**Terminal Equipment Type 1 (TE1):** This functional group includes functions belonging to the functional group TE, and with an interface that complies with the ISDN UNI standard.

**user side:** Terminal terminating layer 1 aspects of TE1, TA and NT2 functional groups.

### 3.2 Symbols

For the purposes of this ETS, the following symbols apply:

ONE	binary "1"
ZERO	binary "0"

### 3.3 Abbreviations

For the purpose of this ETS, the following abbreviations apply:

AIS	Alarm Indication Signal
AMI	Alternate Mark Inversion
CRC	Cyclic Redundancy Check
dc	direct current
EMC	ElectroMagnetic Compatibility
ET	Exchange Termination
FC	Fault Condition
HDB3	High-Density Bipolar 3 (line code)
ISDN	Integrated Service Digital Network
LOS	Loss Of Signal
MPH	Management (entity) - PPhysical (layer) [primitive]
MPH-AI	MPH Activate Indication
MPH-EI	MPH Error Indication
MTIE	Maximum Time Interval Error
NOF	Normal Operational Frames
NT	Network Termination
PH	PHysical (layer)
PH-AI	PH - Activate Indication
PH-DI	PH - Deactivate Indication
PNT	Private Network Termination
PRBS	Pseudo-Random Binary Sequence
PTN	Private Telecommunications Network
PTNX	Private Telecommunications Network Exchange
RAI	Remote Alarm Indication
SMF	Sub-MultiFrame
TA	Terminal Adapter
TE	Terminal Equipment
UNI	

## 4 Type of configuration

The type of configuration applies only to the layer 1 characteristics of the interface and does not imply any constraints on modes of operation at higher layers.

### 4.1 Point-to-point

The primary rate shall support only the point-to-point configuration.

Point-to-point configuration at layer 1 implies that for each direction only one source (transmitter) and one sink (receiver) are connected to the interface. The maximum reach of the interface in the point-to-point configuration is limited by specification for the electrical characteristics of transmitted and received pulses and the type of interconnecting cable.

#### 4.2 Location of interface

The electrical characteristics apply to the interface points  $I_A$  and  $I_B$  of figure 1.



NOTE:  $I_A$  is located at the input and output ports of the TE.  $I_B$  is located at the input and output ports of the NT.

Figure 1: Location of interfaces

#### 4.3 Interface wiring

The magnitude of the characteristic impedance of symmetrical type interface cable shall be  $120 \Omega \pm 20 \%$  in a frequency range from 200 kHz to 1 MHz and  $120 \Omega \pm 10 \%$  at 1 MHz.

The use of shielded interface cables may be required to meet radiation emission and immunity requirements. Therefore the Terminal Equipment (TE) and the Network Termination (NT) shall have provided a point on the equipment where a shield of the interface cable can, and if provided shall be connected to.

This point shall be designed respecting EMC requirements providing access to the signal reference for the transmitter and receiver of the equipment interface.

Application of interface cable with individually shielded pairs or with a common shield for both pairs shall be possible.

#### 4.4 Interface connector

The interface connector and contact assignments is specified in EN 60603-7 [5] and the contact assignments in table 1. However permanent wiring connections from TE to NT are also permitted.

Table 1: contact assignments

Contact	Network interface
1 & 2	Transmit pair
3	Unused
4 & 5	Received pair
6	Unused
7	Unused
8	Unused
Note: The transmit pair is the output from the network interface. The receive pair is the input to the network interface	

## 5 Functional characteristics

### 5.1 Summary of functions (layer 1)

TE		NT
B-, H0- or H1-channels	<--->	B-, H0- or H1-channels
1 D-channel 64 kbit/s	<--->	1 D-channel 64 kbit/s
Bit timing	<--->	Bit timing
Octet timing	<--->	Octet timing
Frame alignment	<--->	Frame alignment
Power feeding	---->	Power feeding
Maintenance	<--->	Maintenance
CRC procedure	<--->	CRC procedure

NOTE: This power feeding function uses a separate pair of wires.

Figure 2: Functional characteristics

**B-channel:** This function shall provide for the bi-directional transmission of independent B-channel signals each having a bit rate of 64 kbit/s. A B-channel may be assigned to any time slot, except time slots 0 and 16.

**D-channel:** This function shall provide for the bi-directional transmission of one D-channel signal at a bit rate of 64 kbit/s. The D-channel shall be assigned to time slot 16.

**H0-Channel:** This function shall provide for the bi-directional transmission of up to 5 independent H0 signal, each having a bit rate of 384 kbit/s. A H0-channel may be assigned to any 6 time slots, except time slots 0 and 16.

**H1-channel:** This function shall provide for the bi-directional transmission of 1 H1 channel having a bit rate of 1 920 kbit/s. A H1-channel shall be assigned to time slots 1 to 15 and 17 to 31.

**Bit timing:** This function shall provide bit (signal element) timing to enable the TE or NT to recover information from the aggregate bit stream.

**Octet timing:** This function shall provide 8 kHz timing towards TE or NT for the purpose of supporting an octet structure for voice coders and for other timing purposes as required.

**Frame alignment:** This function shall provide information to enable the TE or NT to recover the time-division multiplexed channels. Time slot 0 shall provide the frame alignment in accordance with subclause 6.8.1.

**Power feeding:** This function shall provide for the capability to transfer power across the interface towards the NT1.

**Maintenance:** This function shall provide information concerning operational or failure conditions of the interface. The network reference configuration for maintenance activities on primary rate subscriber access is given in ETR 001 [9].

**Cyclic Redundancy Check (CRC)-4 procedure:** This function shall provide for the protection against false framing and may provide for error performance monitoring of the interface.

## 5.2 Interchange circuits

Two interchange circuits, one for each direction, shall be used for the transmission of digital signals. All the functions listed above, with the exception of power feeding and possibly maintenance, are combined into two composite digital signals, one for each direction of transmission.

If power feeding via the interface is provided, an additional interchange circuit shall be used for power feeding.

The two wires of the pairs carrying the digital signal may be reversed.

## 5.3 Activation/deactivation

The interfaces for the primary rate UNI shall be active at all times. No activation/deactivation procedures shall be applied at the interface. However, for consistency in the layer model between primary rate and basic rate the same set of primitives shall be used. The exchange of these primitives and state changes are illustrated in figure 3.

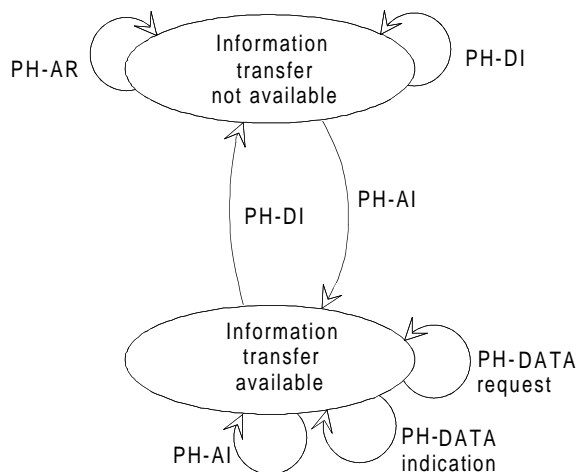

a) Layer 1 - Layer 2

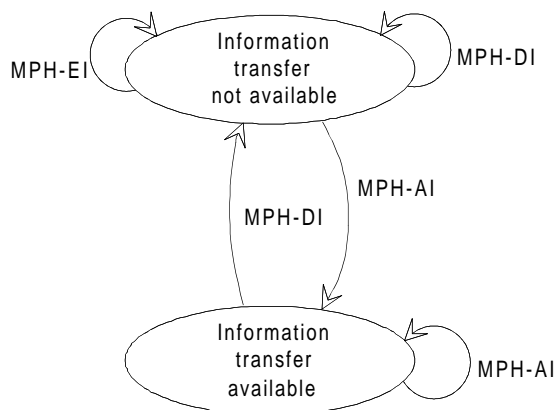

b) Layer 1 - Management; User side

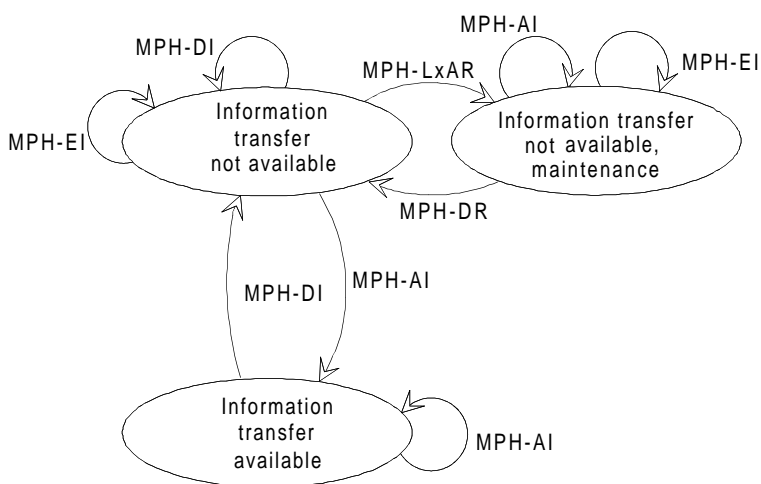

c) Layer 1 - Management; Network side

NOTE: All possible transitions are shown; refer to ETS 300 233 [16] for further information about maintenance procedures.

Figure 3: Exchange of primitives



## 5.4 Definition of primitives

The primitives given in table 2 shall be used between layers 1 and 2 and between layer 1 and the management entity.

**Table 2: Physical layer primitives**

	Specific name		Parameter		Parameter data content
	REQUEST	INDICATION	Priority indicator	Parameter data	
Layer 1 <-> Layer 2					
PH-DATA	U/N	U/N	X (see note 2)	X	DL-PDU
PH-ACTIVATE	U/N (see note 3)	U/N	-	-	
PH-DEACTIVATE	-	U/N	-	-	
Layer 1 <-> Management					
MPH-ERROR	-	U/N	-	X	Type of error
MPH-ACTIVATE	-	U/N	-	-	
MPH-DEACTIVATE	N (see note 4)	U/N	-	-	
MPH-LxACTIVATE	N (see note 1)	-	-	X	Loopback indicator
U = Exists at user side; N = Exists at network side; X = Exists; - = Does not exist					
NOTE 1:	This is used in association with access digital section functions within the network side, see ETS 300 233 [16].				
NOTE 2:	Priority indicator applies only to the request type. The priority indicator shall be used to give priority to information belonging to priority class 1 if queues for DL-PDUs are implemented at layer 1.				
NOTE 3:	This primitive is given for consistency with layer 2 but not used in the layer 1 interface status procedures because the procedures are defined for permanent layer 1 activation.				
NOTE 4:	This primitive is to request a loopback release within the network side which was invoked by an MPH-LxACTIVATE, refer to ETS 300 233 [16].				

## 5.5 Frame structure

### 5.5.1 Number of bits per time slot

A time slot shall consist of eight bits, numbered from 1 to 8.

### 5.5.2 Number of timeslots per frame

A frame shall consist of thirty-two time slots, numbered from 0 to 31. The number of bits per frame is 256 and the frame repetition rate is 8 000 frames/s.

### 5.5.3 Assignments of bits in time slot 0

Bits 1 to 8 of the frame (time slot 0) shall be as shown table 3.

Table 3: Allocation of bits 1 to 8 of the frame

Bit number	1	2	3	4	5	6	7	8
<b>Alternate frames</b>								
Frame containing the frame alignment signal	$S_i$	0	0	1	1	0	1	1
	Frame alignment signal							
Frame not containing the frame alignment signal	$S_i$	1	A	$S_{a4}$	$S_{a5}$	$S_{a6}$	$S_{a7}$	$S_{a8}$
	(see note 1)	(see note 2)	(see note 3)	(see note 4)				
NOTE 1: $S_i$ bits are used for CRC-4 multiframe. NOTE 2: This bit is fixed at ONE to assist in avoiding simulations of the frame alignment signal. NOTE 3: A = RAI. In undisturbed operation, set to ZERO; in alarm condition (RAI), set to ONE. NOTE 4: Bits $S_{a4}$ to $S_{a8}$ shall be set to ONE by TEs. $S_{a4}$ and $S_{a8}$ are reserved for international standardization $S_{a5}$ to $S_{a7}$ are reserved for national use. TEs shall ignore any received pattern.								

5.5.4 Description of the CRC-4 procedure in bit 1 of the frame

5.5.4.1 Allocation of bit 1 to 8 of the frame for a complete multiframe

The allocation of bits 1 to 8 of the frame is shown in table 4 for a complete CRC-4 multiframe.

Table 4: CRC-4 multiframe structure

	Sub-multiframe (SMF)	Frame number	Bits 1 to 8 of the frame							
			1	2	3	4	5	6	7	8
Multi-frame	1	0	$C_1$	0	0	1	1	0	1	1
		1	0	1	A	$S_{a4}$	$S_{a5}$	$S_{a6}$	$S_{a47}$	$S_{a8}$
		2	$C_2$	0	0	1	1	0	1	1
		3	0	1	A	$S_{a4}$	$S_{a5}$	$S_{a6}$	$S_{a47}$	$S_{a8}$
		4	$C_3$	0	0	1	1	0	1	1
		5	1	1	A	$S_{a4}$	$S_{a5}$	$S_{a6}$	$S_{a47}$	$S_{a8}$
		6	$C_4$	0	0	1	1	0	1	1
	7	0	1	A	$S_{a4}$	$S_{a5}$	$S_{a6}$	$S_{a47}$	$S_{a8}$	
	2	8	$C_1$	0	0	1	1	0	1	1
		9	1	1	A	$S_{a4}$	$S_{a5}$	$S_{a6}$	$S_{a47}$	$S_{a8}$
		10	$C_2$	0	0	1	1	0	1	1
		11	1	1	A	$S_{a4}$	$S_{a5}$	$S_{a6}$	$S_{a47}$	$S_{a8}$
		12	$C_3$	0	0	1	1	0	1	1
		13	E	1	A	$S_{a4}$	$S_{a5}$	$S_{a6}$	$S_{a47}$	$S_{a8}$
		14	$C_4$	0	0	1	1	0	1	1
15		E	1	A	$S_{a4}$	$S_{a5}$	$S_{a6}$	$S_{a47}$	$S_{a8}$	
NOTE 1: E = CRC-4 error indication bits (see subclause 5.5.4.3). SMF (block) with error: E = ZERO, SMF (block) without error: E = ONE. NOTE 2: $S_{a4}$ to $S_{a8}$ = Spare bits (see note 4 to table 3). NOTE 3: $C_1$ to $C_4$ = CRC-4 bits (see subclause 5.5.5). NOTE 4: A = RAI (see table 3).										

5.5.4.2 Sub-Multiframe (SMF)

Each CRC-4 multiframe, which is composed of 16 frames numbered 0 to 15, is divided into two 8-frame sub-multiframes, designated SMF 1 and SMF 2 which signifies their respective order of occurrence within the CRC-4 multiframe structure. The SMF is the CRC-4 block size (i.e. 2 048 bits).

### 5.5.4.3 Use of bit 1 in 2 048 kbit/s CRC-4 multiframe

In those frames containing the frame alignment signal (defined in subclause 5.5.3) bit 1 is used to transmit the CRC-4 bits. There are four CRC-4 bits, designated  $C_1$ ,  $C_2$ ,  $C_3$ , and  $C_4$  in each SMF.

In those frames not containing the frame alignment signal (see subclause 5.5.3), bit 1 is used to transmit the 6-bit CRC-4 multiframe alignment signal and two CRC-4 error indication bits (E).

The CRC multiframe alignment signal has the form "001011".

The E-bits shall be used to indicate received errored sub-multiframes by setting the binary state of one E-bit from ONE to ZERO for each errored sub-multiframe. Any delay between the detection of an errored sub-multiframe and the setting of the E-bit that indicates the error state shall be less than 1 second.

The E-bits shall always be taken into account even if the SMF which contains them is found to be errored, since there is little likelihood that the E-bits themselves will be errored.

## 5.5.5 Cyclic Redundancy Check (CRC)

### 5.5.5.1 Multiplication/division process

A particular CRC-4 word, located in sub-multiframe N, is the remainder after multiplication by  $x^4$  and then division (modulo 2) by the generator polynomial  $x^4 + x + 1$ , of the polynomial representation of sub-multiframe N - 1.

When representing the contents of the check block as a polynomial, the first bit in the block, i.e. frame 0, bit 1 or frame 8, bit 1, shall be taken as being the most significant bit. Similarly,  $C_1$  is defined to be the most significant bit of the remainder and  $C_4$  the least significant bit of the remainder.

### 5.5.5.2 Encoding procedure

- a) The CRC-4 bits in the SMF are replaced by ZEROs;
- b) the SMF is then acted upon by the multiplication/division process referred to in subclause 5.5.5.1;
- c) the remainder resulting from the multiplication/division process is stored, ready for insertion into the respective CRC-4 locations of the next SMF.

NOTE: The CRC-4 bits thus generated do not affect the result of the multiplication/division process in the next SMF because, as indicated in a) above, the CRC-4 bit positions in an SMF are initially set to ZERO during the multiplication/division process.

### 5.5.5.3 Decoding procedure

- a) A received SMF is acted upon by the multiplication/division process referred to in subclause 5.5.5.1, after having its CRC-4 bits extracted and replaced by ZEROs;
- b) the remainder resulting from this division process is then stored and subsequently compared on a bit-by-bit basis with the CRC bits received in the next SMF;
- c) if the remainder calculated in the decoder exactly corresponds to the CRC-4 bits received in the next SMF, it is assumed that the checked SMF is error free.

## 5.6 Bit sequence independence

Interface  $I_B$  shall provide bit sequence independent transmission in time slots 1 to 31.

## 5.7 Line code

The line code shall be High-Density Bipolar 3 (HDB3).

## 5.8 Timing considerations

The NT shall derive its timing from the network clock. The TE shall synchronize its timing (bit, octet, framing) from the signal received from the NT and shall synchronize accordingly the transmitted signal.

In an unsynchronized condition (e.g. when the access that normally provides network timing is unavailable) the frequency deviation of the free-running clock shall not exceed  $\pm 50$  ppm.

Any TE which provides more than one interface is declared to be a multiple access TE and shall be capable of taking the synchronizing clock frequency for its internal clock generator from more than one access (or all access links) and synchronize the transmitted signals at each interface accordingly.

A TE (PTNX) which is designed to act as a synchronization master in a private network application shall have a clock accuracy better than  $\pm 32$  ppm.

A Private Telecommunications Network Exchange (PTNX) with a high clock accuracy class of better than  $\pm 1$  ppm may not be able to synchronize its internal clock to an input frequency with a tolerance of  $\pm 32$  ppm. The timing negotiation function being specified for private networks shall guarantee that the PTNX with the higher clock accuracy shall act as the master after re-establishment of the configuration.

A TE which is designed to be connected to the T reference point only or a TE with a free running clock accuracy better than  $\pm 1$  ppm, shall be able to synchronize at the nominal bit rate  $\pm 1$  ppm. Other TEs shall be able to synchronize at the nominal bit rate  $\pm 32$  ppm.

In order to limit the impact on the service performance following the loss of synchronization, the maximum time for resynchronization to the network clock shall be less than 30 s, with the frequency deviation applied to the input port limited to  $\pm 1$  ppm.

## 6 Interface procedure

### 6.1 Definition of signals at the interface

Signals exchanged between the network and user side under normal and fault conditions are listed in table 5. Further information on these signals is given in subclause 7.1.

The detection algorithm for signals given in table 5 and others is defined as follows:

- normal operational frames: the algorithm shall be in accordance with subclauses 6.8.1.2 and 6.8.2;
- loss of frame alignment: the algorithm shall be in accordance with subclause 6.8.1.1;
- RAI: this is detected when both of the two following conditions occur:
  - frame alignment condition;
  - reception of one bit A set to ONE.
- Loss Of Signal (LOS): the equipment shall assume loss of signal when the incoming signal amplitude is more than 20 dB below the nominal output amplitude for this interface for more than 1 ms;

NOTE: The detection of this event is necessary if an implementation cannot detect loss of frame alignment in case of loss of incoming signal.

- Alarm Indication Signal (AIS): this is detected when both of the two following conditions occur:
  - loss of frame alignment;
  - reception of 512 bit periods containing less than 3 ZEROs (reference is made to CCITT Recommendation O.162 [7], paragraph 3.3.2).
- CRC error information: reception of one E bit set to ZERO according to table 5;

- RAI and continuous CRC error information: this event is identified when A bit set to ONE and E bit set to ZERO are continuously received within a persistence check time period of between 10 ms and 50 ms;
- no signal: it is to be understood that the term no signal characterizes a range of transmitted signal levels which do not necessarily have a zero pulse amplitude but may be interpreted by a receiver as loss of signal;
- loss of power or return of power: these are equipment internal events and do not require further definition of the detection mechanism.

**Table 5: Signals between the network and user side under normal and fault conditions**

Name	List of the signals
Normal operational frame	Operational frames with: - Active associated CRC bits; - CRC error information (see subclause 5.5.4.3); - no defect indication.
RAI	Operational frame with: - Active associated CRC bits; - CRC error information (see note); - with remote alarm indication, (see table 3).
LOS	No receiving incoming signal
AIS	Continuous stream of ONEs (ITU-T Recommendation M.20 [8])
CRC error information	E bit according to subclause table 4, set to "ZERO" if CRC block is received with error.
NOTE: Contiguous CRC blocks with errors shall result in contiguous CRC error information.	

## 6.2 Definitions of state tables at network and user sides

The user side and network side of the interface have to inform each other on the layer 1 states in relation to the different defects that could be detected.

For that purpose, two state tables are defined, one at the user side and one at the network side. States at the user side (F states) are defined in subclause 6.3 and states at the network side (G states) are defined in subclause 6.4. The state tables are defined in subclause 6.5.

FC1 to FC4 that could occur at the network side or between the network side and user side are defined in figure 4. These fault conditions directly affect the F and G states. Information on these fault conditions are exchanged between the user and network sides in the form of signals defined in table 5.

The TE and NT shall inform layer 2 (of the D-channel protocol), the management entity and the other side of the interface of the status identified by the equipment according to the state tables.

NOTE 1: Only those stable states needed for operation and maintenance of user and network side of the interface (system reactions, user and network responsible information) are defined. The transient states relative to the detection of CRC error information, AIS and RAI are not taken into account. It should be taken into account that during state transitions error indication primitives PPhysical (layer) (PH) and Management (entity) - Physical (layer) [primitive] (MPH) are sent to higher layers.

NOTE 2: The user does not need to know where a failure is located in the network. The user should be informed on the availability and the continuity of the layer 1 service.

NOTE 3: The user has all information relative to the CRC associated with each direction of its adjacent CRC section. The supervision of the quality of this section is the user's responsibility.

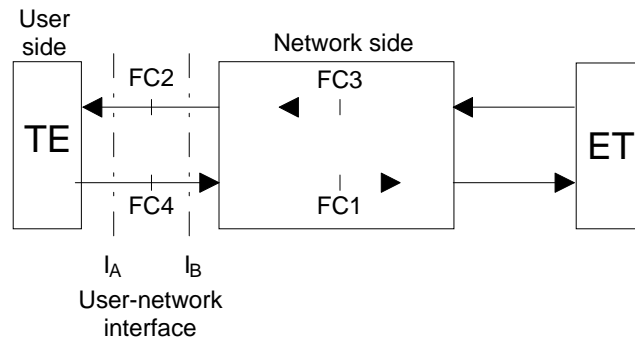

Figure 4: Location of fault conditions (FC) relative to interface

### 6.3 Layer 1 states on the user side of the interface

FO state: Loss of power on the user side:

- in general, the TE can neither transmit nor receive signals.

F1 state: Operational state:

- network timing and layer 1 service is available;
- the user side transmits and receives operational frames with associated CRC bits and with temporary CRC error information (see note 1);
- the user side checks the received frames and the associated CRC bits, and transmits to the network side operational frames containing the CRC error information, if a CRC error is detected.

F2 state: Fault condition No. 1:

- this fault state corresponds to the fault condition FC1;
- network timing is available at the user side;
- the user side receives operational frames with associated CRC bits and with temporary CRC error information (see note 1);
- the received frames contain RAI;
- the user side transmits operational frames with associated CRC bits;
- the user side checks the received frames and the associated CRC bits and transmits to the network side operational frames containing the CRC error information, if a CRC error is detected.

F3 state: Fault condition No. 2:

- this fault state corresponds to the fault condition FC2;
- network timing is not available at the user side;
- the user side detects loss of incoming signal (this will involve loss of frame alignment);
- the user side transmits operational frames with associated CRC bits and RAI.

F4 state: Fault condition No. 3:

- this fault state corresponds to fault condition FC3;
- network timing is not available at the user side;
- the user side detects AIS;
- the user side transmits to the network side operational frames with associated CRC bits and RAI.

F5 state: Fault condition No. 4:

- this fault state corresponds to the fault condition FC4;
- network timing is available at the user side;
- the user side receives operational frames with continuous CRC error information (see note 2);
- the received frames contain RAI;
- the user side transmits operational frames with associated CRC bits;
- the user side checks the received frames and the associated CRC bits. It may transmit to the network side operational frames containing the CRC error information, if a CRC error is detected.

F6 state: Power on state:

- this is a transient state and the user side may change the state after detection of the signal received.

NOTE 1: The interpretation of the CRC error information depends on whether network option 1 or 2 is used.

NOTE 2: Only in network options 2. The condition of "continuous CRC error information" corresponds to loss of incoming signal or loss of frame alignment on the network side.

#### 6.4 Layer 1 states at the network side of the interface

G0 state: Loss of power in the NT1:

- in general, the NT1 can neither transmit nor receive any signal.

G1 state: Operational state:

- the network timing and layer 1 service is available;
- the network side transmits and receives operational frames with associated CRC bits and temporary CRC error information;
- the network side checks the received frames and the associated CRC bits and transmits to the user side the CRC error information if a CRC error is detected.

G2 state: Fault condition No. 1:

- this fault state corresponds to the fault condition FC1;
- network timing is provided to the user side;
- the network side receives operational frames with associated CRC bits;
- the network side transmits to the user side operational frames with associated CRC bits and RAI. The operational frames may contain CRC error information.

G3 state: Fault condition No. 2:

- this fault state corresponds to the fault condition FC2;
- network timing is not provided to the user side;
- the network side transmits to the user side operational frames with associated CRC bits;
- the network side receives operational frames with associated CRC bits and RAI.

G4 state: Fault condition No. 3:

- this fault state corresponds to the fault condition FC3;
- network timing is not provided to the user side;
- the network side transmits AIS;
- the network side receives operational frames with associated CRC bits and RAI.

G5 state: Fault condition No. 4:

- this fault state corresponds to the fault condition FC4;
- network timing is provided to the user side;
- the network side detects loss of incoming signal or loss of frame alignment;
- the network side transmits to the user side operational frames with associated CRC bits and RAI and continuous CRC error information.

G6 state: Power on state:

- this is a transient state and the network side may change the state after detection of the signal received.

## 6.5 State tables

Operational functions are defined in table 6 for the layer 1 states at the user side of the interface and in table 7 for the network side. The exact reaction in case of double faults may depend on the type of double fault condition and the sequence in which they occur.

Table 6: Primary rate layer 1 state matrix at user side of the interface

	Initial state	F0	F1	F2	F3	F4	F5	F6
Definition of the states	Operational condition or failure condition	Power off at user side	Operational	FC1	FC2	FC3	FC4	Power on at user side
	Signal transmitted towards interface	No signal	Normal operational frames	Normal operational frames	Frames with RAI	Frames with RAI	Normal operational frames	No signal
New event, detected at the receiving side	Loss of TE power	/	PH-DI MPH-DI MPH-EI0 F0	MPH-EI0 F0	MPH-EI0 F0	MPH-EI0 F0	MPH-EI0 F0	MPH-EI0 F0
	Return of TE power	F6	/	/	/	/	/	/
	Normal operational frames from network side	/	-	PH-AI MPH-AI F1	PH-AI MPH-AI F1	PH-AI MPH-AI F1	PH-AI MPH-AI F1	/
	Reception of RAI 1)	/	PH-DI MPH-DI MPH-EI1 F2	-	MPH-EI1 F2	MPH-EI1 F2	MPH-EI1 F2	MPH-EI1 F2
	Loss of signal or frame alignment	/	PH-DI MPH-DI MPH-EI2 F3	MPH-EI2 F3	-	MPH-EI2 F3	MPH-EI2 F3	MPH-EI2 F3
	Reception of AIS	/	PH-DI MPH-DI MPH-EI3 F4	MPH-EI3 F4	MPH-EI3 F4	-	MPH-EI3 F4	MPH-EI3 F4
	Reception of RAI and continuous CRC error report	/	PH-DI MPH-DI MPH-EI4 F5	MPH-EI4 F5	MPH-EI4 F5	MPH-EI4 F5	-	MPH-EI4 F5
Primitive from layer 2	PH-AR	/	PH-AI MPH-AI -	PH-DI MPH-DI -	PH-DI MPH-DI -	PH-DI MPH-DI -	PH-DI MPH-DI -	PH-DI MPH-DI -
- No state change / Impossible situation				PH-x MPH-y Fz	Issue primitive x Issue management primitive y Go to state Fz			
NOTE 1:	FC4 is present at accesses to the public ISDN and leased lines which process CRC-4. The CRC-4 error allows the user-side equipment to localize a fault, indicated by means of RAI, to either: <ul style="list-style-type: none"> <li>- the network side (FC1), if frames without continuous CRC error reports are received; or</li> <li>- the user side (FC4), if frames with continuous CRC error reports are received.</li> </ul>							
NOTE 2:	At unstructured leased lines, the faults FC1 and FC4 are indicated identically at the interface, therefore, the signal "RAI with continuous CRC error report" does not occur.							



Table 7: Primary rate layer 1 state matrix at network side of the interface

	Initial state	G0	G1	G2	G3	G4	G5	G6	
Definition of the states	Operational condition or failure condition as seen from the interface	Power off at NT	Operational	FC1	FC2	FC3	FC4	Power on at NT	
	Signal transmitted towards interface	No signal	Normal operational frames	RAI b)	Normal operational frames	AIS	RAI and E-bit = ZERO	No signal	
New event, detected at the receiving side	Loss of NT power	/	PH-DI MPH-DI MPH-EI0 G0	MPH-EI0 G0	MPH-EI0 G0	MPH-EI0 G0	MPH-EI0 G0	MPH-EI0 G0	
	Return of NT power	G6	/	/	/	/	/	/	
	Normal operational frames, no internal network failure	/	-	PH-AI MPH-AI G1	PH-AI MPH-AI G1	PH-AI MPH-AI G1	PH-AI MPH-AI G1	/	
	Internal network failure FC1	/	PH-DI MPH-DI MPH-EI1 G2	-	MPH-EI1 G2	MPH-EI1 G2	MPH-EI1 G2	MPH-EI1 G2	MPH-EI1 G2
					X	G2	G2		
	Reception of RAI FC2	/	PH-DI MPH-DI MPH-EI2 G3	MPH-EI2 G3	-	MPH-EI2 G3	MPH-EI2 G3	MPH-EI2 G3	MPH-EI2 G3
						X	G3	G3	
	Internal network failure FC3	/	PH-DI MPH-DI MPH-EI3 G4	MPH-EI3 G4	MPH-EI3 G4	-	MPH-EI3 G4	MPH-EI3 G4	MPH-EI3 G4
X						X	X		
Loss of operational frames FC4	/	PH-DI MPH-DI MPH-EI4 G5	MPH-EI4 G5	MPH-EI4 G5	MPH-EI4 G5	MPH-EI4 G5	MPH-EI4 G5	MPH-EI4 G5	
					X	X	G5		
Primitive from layer 2	PH-AR	/	PH-AI MPH-AI-	PH-DI MPH-DI-	PH-DI MPH-DI-	PH-DI MPH-DI-	PH-DI MPH-DI-	PH-DI MPH-DI-	
<b>Single fault condition</b>				<b>Double fault condition</b>					
<p>- No state change. / Impossible situation. PH-x Issue primitive x MPH-y Issue management primitive y Fz Go to state Fz</p>				<p>MPH-y Second fault is dominant. Action to be taken when second fault occurs. Gz X The disappearance of the first fault is not visible at the interface since the second fault is dominant and the state has changed already to Gz. MPH-y<sup>3</sup> First fault is dominant. Therefore the state will not change when the second fault occurs but the error indication may be given to the management if possible. Gz Action to be taken when first (Dominant fault disappears).</p>					

## 6.6 Allocation of time slots

B-channels, D-channel, H0-channels and H1-channel shall be allocated as given in table 8.

**Table 8: Allocation of time slots**

Channel	Time slot
B-channel	Any time slot from 1 to 15 or from 17 to 31
D-channel	16
H0-channel	Any six slots
H1-channel	30 slots, 1 to 15 and 17 to 31

## 6.7 Interframe (layer 2) time fill

Contiguous HDLC flags shall be transmitted on the D-channel when its layer 2 has no frames to send. This applies also for power-up and restart conditions.

## 6.8 Frame alignment and CRC-4 procedures

### 6.8.1 Loss and recovery of basic frame alignment

#### 6.8.1.1 Loss of basic frame alignment

Frame alignment shall be lost when:

- three consecutive incorrect frame alignment signals have been received; or
- multiframe alignment is not achieved with 8 ms after gaining basic frame alignment (see subclause 6.8.2); or
- $\geq 915$  errored SMF out of 1 000 are received (see subclause 6.8.3.2).

Optionally basic frame alignment may also be lost when bit 2 in time slot 0 in frames not containing the frame alignment signal has been received with an error on three consecutive occasions.

#### 6.8.1.2 Strategy for basic frame alignment recovery

Basic frame alignment shall be recovered when the following sequence is detected:

- for the first time, the presence of the correct frame alignment signal;
- the absence of the frame alignment signal in the following frame detected by verifying that bit 2 of the basic frame is ONE;
- for the second time, the presence of the correct frame alignment signal in the next frame.

To avoid the possibility of a state in which no basic frame alignment can be achieved due to the presence of a spurious basic frame alignment signal, the following procedure may be used: When a valid basic frame alignment signal is detected in frame  $n$ , a check shall be made to ensure that a frame alignment signal does not exist in frame  $n + 1$ , and also that a frame alignment signal exists in frame  $n + 2$ . Failure to meet one or both of these requirements shall cause a new search to be initiated in frame  $n + 2$ .

### 6.8.2 CRC multiframe alignment using information in bit 1 of the basic frame

If a condition of assumed basic frame alignment has been achieved, CRC multiframe alignment shall be deemed to have occurred if at least two valid CRC multiframe alignment signals can be located within 8 ms, the time separating two CRC multiframe alignment signals being 2 ms or a multiple of 2 ms. The search for the CRC multiframe alignment signal shall be made only in basic frames not containing the frame alignment signal.

If multiframe alignment cannot be achieved within 8 ms, it shall be assumed that basic frame alignment is due to a spurious frame alignment signal and a re-search for frame alignment shall be initiated.

The re-search for basic frame alignment shall be started at a point just after the location of the assumed spurious basic frame alignment signal. This will usually avoid realignment onto the spurious basic frame alignment signal.

Consequent actions taken as a result of loss of basic frame alignment shall no longer be applied once frame alignment has been recovered. However, if CRC multiframe alignment cannot be achieved within a time limit in the range of 100 ms to 500 ms, consequent actions shall be taken equivalent to those specified for loss of frame alignment (i.e. RAI shall be set permanently until multiframe alignment has been recovered).

### **6.8.3 CRC bit monitoring**

If basic frame and CRC multiframe alignment have been achieved, the monitoring of the CRC bits in each sub-multiframe shall commence.

#### **6.8.3.1 Monitoring procedure**

- a) A received CRC sub-multiframe (SMF) is acted upon by the multiplication/division process defined in subclause 5.5.5.1 after having its CRC bits extracted and replaced by ZEROs.
- b) The remainder resulting from the division process is then stored and subsequently compared on a bit-by-bit basis with the CRC bits received in the next SMF.
- c) If the remainder exactly corresponds to the CRC bits contained in the next SMF of the received signal, it is assumed that the checked SMF is error free.

#### **6.8.3.2 Monitoring for false basic frame alignment**

It shall be possible to detect a condition of false basic frame alignment within 1 second and with a probability greater than 0,99. On detection of such an event, a re-search for basic frame alignment shall be initiated.

With a random error ratio of  $10^{-3}$  the probability of falsely initiating a search for basic frame alignment due to an excessive number of errored CRC blocks shall be less than  $10^{-4}$  over a 1 second period.

Figure 5 shows an illustration of the procedure to be followed in passing from the basic frame alignment search to error monitoring using CRC.

To achieve the probability bounds stated above, a threshold count shall be 915 errored CRC blocks out of 1 000, with the understanding that a count of  $\geq 915$  errored CRC blocks indicates false frame alignment.

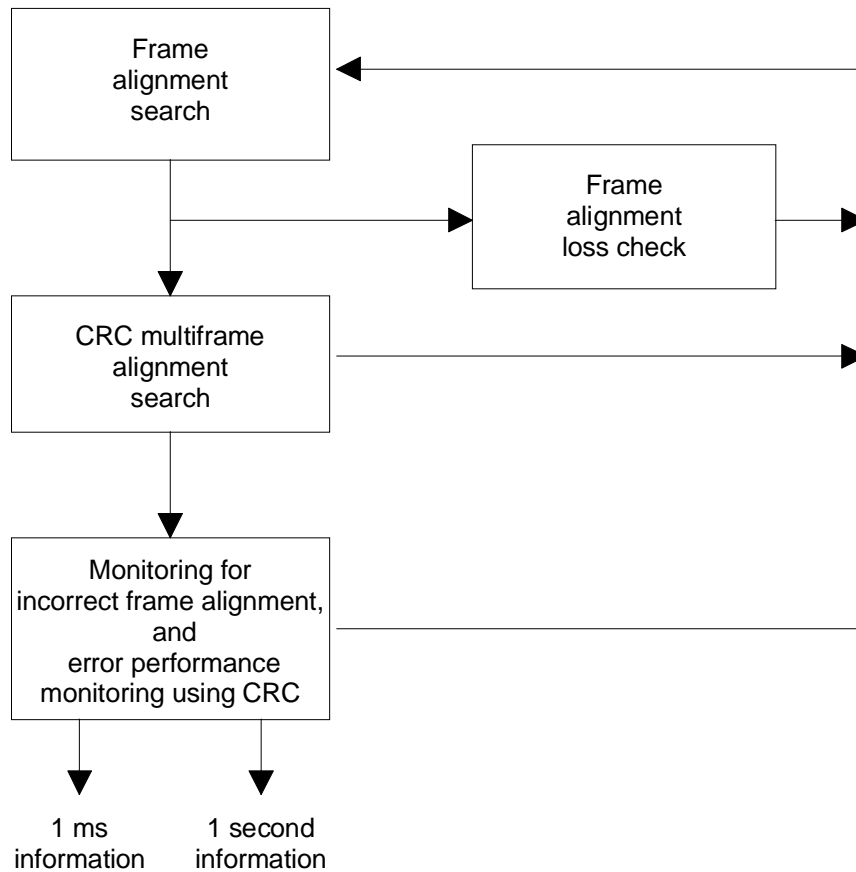

**Figure 5: Procedure to be followed in passing from the basic frame alignment search to error monitoring using a cyclic redundancy check (CRC) (2 048 kbit/s)**

### 6.8.3.3 Error performance monitoring using CRC-4

Information on the status of the CRC processing shall be made available in two forms:

- a) **Direct information:** Every time a CRC block is detected in error, it will be necessary to indicate this condition;
- b) **Integrated information:** In consecutive 1 second periods, the number of errored CRC blocks shall be made available. This number will be in the range 0 to 1 000 (decimal).

## 7 Maintenance at the interface

The network reference configuration for the maintenance activities on primary rate subscriber access is given in ETR 001 [9].

The associated maintenance procedure, which is described there, needs a continuous supervision procedure on layer 1 for the automatic fault detection, automatic failure confirmation and information.

NOTE: The terms anomaly, defect, fault and failure are defined in ITU-T Recommendation M.20 [8].

## 7.1 Definitions of maintenance signals

The RAI signal indicates loss of layer 1 capability at the UNI. RAI propagates towards the network if layer 1 capability is lost in the direction of the user, and RAI propagates towards the user if layer 1 capability is lost in the direction of the network. RAI is coded in bit A, i.e. bit 3 of time slot 0 of the operational frame which does not contain the frame alignment signal (see table 4).

The AIS is used to indicate loss of layer 1 capability in the Exchange Termination (ET)-to-TE direction on the network side of the UNI. A characteristic of AIS is that its presence indicates that the timing provided to the TE may not be the network clock. AIS is coded as all ONEs, 2 048 kbit/s bit stream.

CRC error report: E bit (see table 4) in operational frames.

## 7.2 Use of CRC procedure

### 7.2.1 Introduction

At the UNI the CRC procedure according to this ETS is applied to gain security in frame alignment and detect block errors. The CRC error information uses the E bits as defined in table 4. The coding is E = ZERO for a block with failure and E = ONE for a block without failure. With respect to CRC error information to the other side of the interface and processing of this information, two different options exist, one has CRC processing in the transmission link and the other not.

The use of the CRC procedure at the UNI implies:

- a) that the user side shall generate towards the interface a 2 048 kbit/s frame with associated CRC bits;
- b) that the network side shall generate towards the interface a 2 048 kbit/s frame with associated CRC bits;
- c) that the user side shall monitor the CRC bits associated with the received frames (CRC codes calculation and comparison with received CRC codes);
- d) that the user side shall detect the CRC blocks received with error;
- e) that the user side shall generate the CRC error information according to the CRC procedure;
- f) that the network side shall monitor the CRC bits associated with the received frames (CRC codes calculation and comparison with received CRC codes);
- g) that the network side shall detect the CRC blocks received with error;
- h) that the network side shall generate the CRC error information according to the CRC procedure.

### 7.2.2 Localization of the CRC functions from the user point of view

#### 7.2.2.1 No CRC processing in the transmission link

Figure 6 gives an example of PTNX interconnection using an unstructured leased line that does not process CRC-4.

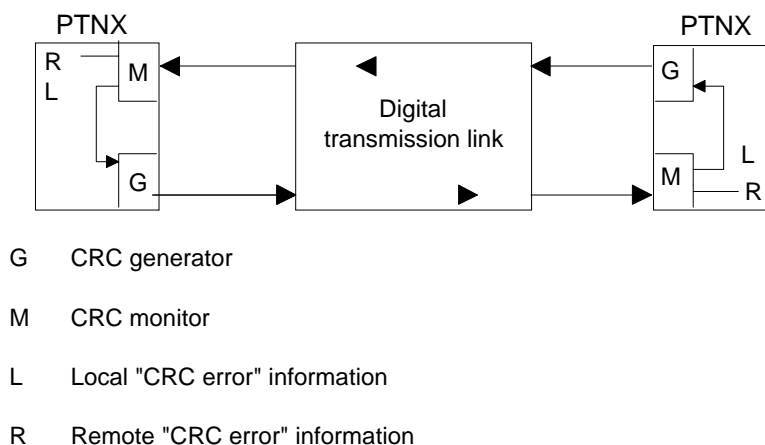

**Figure 6: Localization of CRC processing functions for PTNX interconnection when the transmission link does not process the CRC**

### 7.2.2.2 CRC processing in the digital transmission link

Figure 7 gives the location of CRC function processes in a subscriber access with CRC processing in the NT.

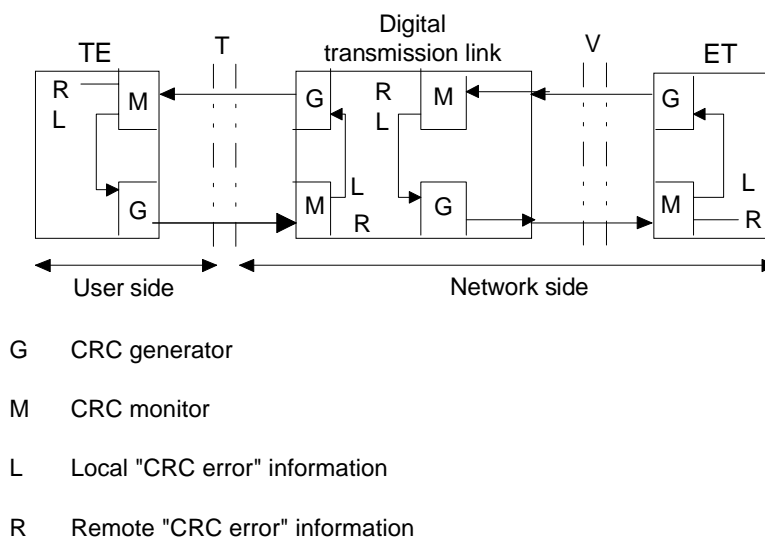

**Figure 7: Localization of CRC processing functions for a subscriber access with CRC processing in the transmission link**

## 7.3 Maintenance functions

### 7.3.1 General requirements

The equipment located on the user side and on the network side of the interface shall:

- detect the anomalies;
- detect the defects;
- take actions for reporting the detected anomalies and defects (defect indication signals AIS, RAI);
- detect the received defect indication signals.

## **7.3.2 Maintenance functions on the user side**

### **7.3.2.1 Anomalies and defect detection**

The user side shall detect the following defects or anomalies:

- loss of power on the user side;
- loss of incoming signal at interface (see note);
- loss of frame alignment (see subclause 6.8.1.1);
- CRC error.

NOTE: The detection of this defect is required only when it has not the effect of a loss of frame alignment indication.

### **7.3.2.2 Detection of defect indication signals**

The following defect indications received at interface shall be detected by the user side:

- RAI (see note);
- AIS.

NOTE: The RAI signal is used to indicate loss of layer 1 capability. It may be used to indicate:

- loss of signal or loss of framing;
- excessive CRC errors (optional);
- loopbacks applied in the network.

The conditions of excessive CRC errors are outside the scope of this ETS.

### **7.3.2.3 Consequent actions**

Table 9 gives the actions that the user side (TE function) has to take after the detection of a defect or of a defect indication signal.

When the defect conditions have disappeared or when the defect indication signals are no longer received, the defect indications AIS and RAI shall disappear as soon as possible.

The following points are required to ensure that an equipment is not removed from service or put into service due to short breaks in transmission or on detection of normal operational frames by layer 1 respectively.

- a) The persistent receipt of signals other than normal operational frames shall be verified by a timer T1 of 100 ms to 1 000 ms before PH-DI is issued;
- b) The persistent receipt of normal operational frames shall be verified by a timer T2 of 10 to 100 ms before PH-AI is issued;
- c) T1 shall be suspended when T2 is started. T1 shall resume running when T2 is reset;
- d) T1 shall be reset when T2 expires;
- e) T2 shall be reset on receipt of signals other than normal operational frames.

## **7.3.3 Maintenance functions on the network side**

### 7.3.3.1 Defect detection

All the following defect conditions shall be detected by the network side of the interface at reference point T (NT1, LT, ET functions) (see note 2):

- loss of power on the network side;
- loss of incoming signal;
- loss of frame alignment (see subclause 6.8.1.1);
- CRC error.

NOTE 1: The equipment of the primary rate digital link (NT1, LT, etc.) have to detect loss of incoming signal and then to generate downstream towards the interface the defect indication signal AIS.

NOTE 2: Some equipment in the network may detect only part of the defects or defect conditions listed above.

**Table 9: Defect conditions and defect indication signals detected by the user side and consequent actions**

Defect conditions and defect indication signals detected by the user side	Consequent actions	
	Defect indication at the interface	
	Generation of RAI	Generation of CRC error information (see note 4)
Loss of power on user side	Not applicable	Not applicable
Loss of signal	Yes	Yes (see note 1)
Loss of frame alignment	Yes	No (see note 2)
Reception of RAI	No	No
Reception of AIS	Yes	No (see note 3)
Detection by TE/NT2 of CRC errors	No	Yes
NOTE 1: Only when loss of frame alignment has not yet occurred.		
NOTE 2: The loss of frame alignment inhibits the process associated with the CRC procedure.		
NOTE 3: The AIS signal is detected only after the fault "loss of frame alignment", thus the process associated with the CRC procedure is inhibited.		
NOTE 4: If CRC errors are detected in frames carrying the RAI signal, then CRC error reports shall be generated.		

### 7.3.3.2 Detection of defect indication signals

The following defect indications received at interface shall be detected by the network side:

- RAI;
- CRC error information.

### 7.3.3.3 Consequent actions

Table 10 gives the actions that the network side (NT1, ET functions) has to take after defect detection or defect indication detection.

When the defect conditions have disappeared or the defect indication signals are no longer received, the defect indication signals AIS and RAI shall disappear as soon as possible.

The following points are required to ensure that an equipment is not removed from service or put into service due to short breaks in transmission or on detection of normal operational frames by layer 1 respectively:

- a) the persistent receipt of signals other than normal operational frames shall be verified by a timer T1 of 100 to 1 000 ms before PH-DI is issued;



- b) the persistent receipt of normal operational frames shall be verified by a timer T2 of 10 to 100 ms before PH-AI is issued;
- c) T1 shall be suspended when T2 is started. T1 shall resume running when T2 is reset;
- d) T1 shall be reset when T2 expires;
- e) T2 shall be reset on receipt of signals other than normal operational frames.

**Table 10: Defect conditions and defect indication signals detected by the network side of interface, and consequent actions**

Defect conditions and defect indication signals detected by the network side	Consequent actions		
	Defect indication at the interface		
	Generation of RAI	Generation of AIS	Generation of CRC error information
Loss of power on network side	Not applicable	Yes, if possible	Not applicable
Loss of signal	Yes	No	Yes (see note 1)
Loss of frame alignment	Yes	No	Option 1: No Option 2: Yes
Detection of defect in the network-to-user direction	No	Yes	No
Reception of RAI	No	No	No (see note 2)
Detection of defect in the user-to-network direction up to ET	Yes	No	No
Detection of CRC errors	No	No	Yes
Reception of CRC error information	No	No	No
Excessive CRC error ratio	Yes (Optional)	No	Not applicable
NOTE 1: Only when loss of frame alignment has not yet occurred.			
NOTE 2: If CRC errors are detected in frames carrying the RAI signal, then CRC error reports shall be generated.			

## 8 Electrical characteristics

The requirements of subclauses 8.2.2, 8.3.1, 8.3.3, 8.3.4 and 8.4 are applicable for the frequency range defined in subclause 5.8.

The requirements of subclauses 8.3.3, 8.3.4 and 8.4 are applicable for the attenuation range defined in subclause 8.3.1.

### 8.1 Type of interface

The interface shall be balanced with a nominal impedance of 120  $\Omega$ .

### 8.2 Specifications at the output ports

#### 8.2.1 Bit rate

The nominal bit rate shall be 2 048 kbit/s.

#### 8.2.2 Waveform shape

The output signal shall conform to table 11.

Table 11: Waveform shape at the output port

Pulse shape (nominally rectangular)	All marks of a valid signal should conform with the mask (see figure 8) irrespective of the sign. The value V corresponds to the nominal peak value.
Test load impedance	120 Ω resistive
Nominal peak voltage of a mark (pulse)	3 V
Peak voltage of a space (no pulse)	0 V ± 0,3 V
Nominal pulse width	244 ns
Ratio of the amplitudes of positive and negative pulses at the centre of the pulse interval	0,95 to 1,05
Ratio of the widths of positive and negative pulses at the nominal half amplitude	0,95 to 1,05

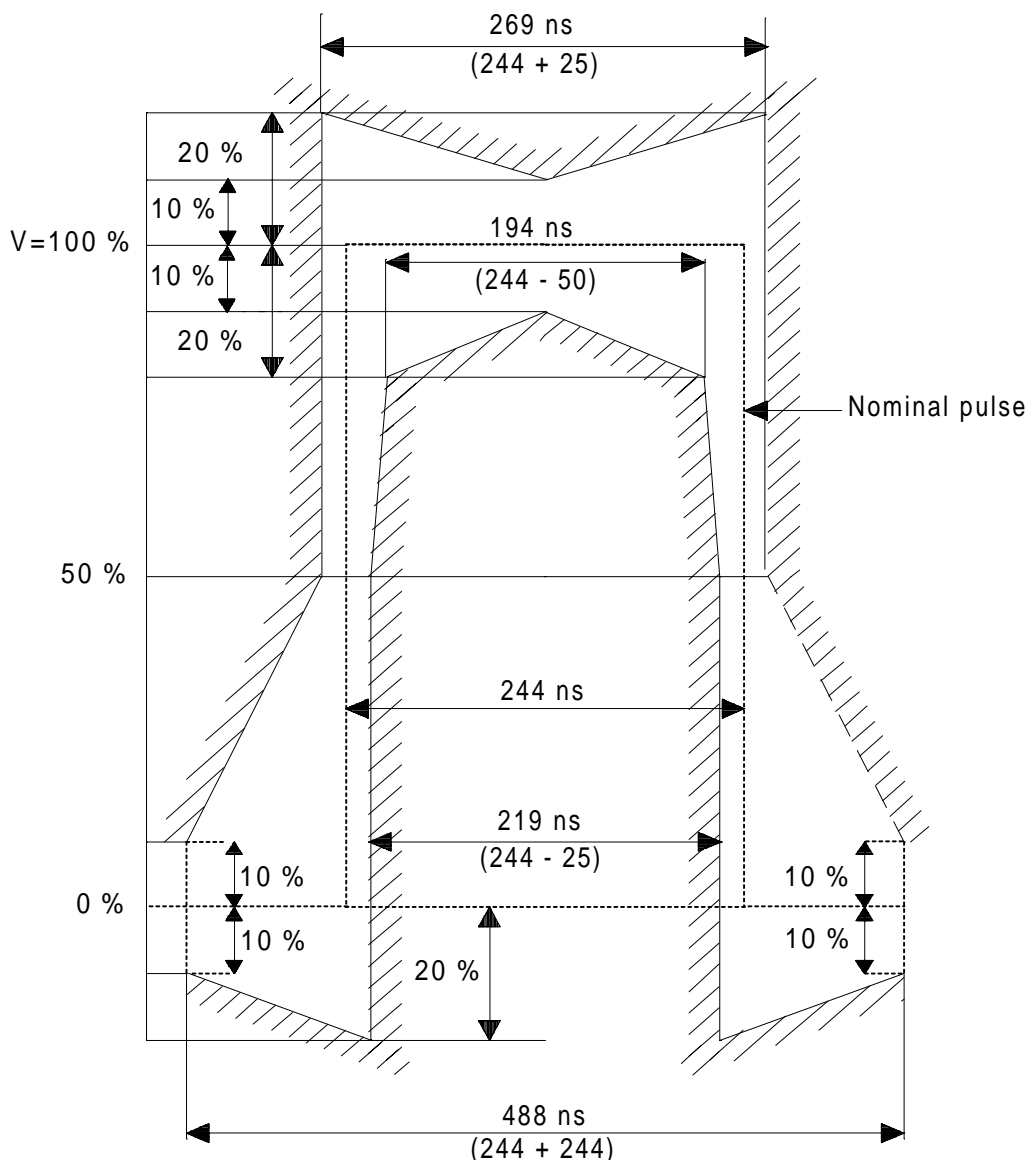

NOTE: V corresponds to the nominal peak value.

Figure 8: Mask of the pulse at the 2 048 kbit/s interface

### 8.2.3 Return loss at the output port

In order to prevent bit errors due to reflection, the return loss at the output port with respect to the nominal impedance of 120  $\Omega$  shall be greater or equal than the values of table 12.

**Table 12: Return loss at the output port**

Frequency range (kHz)	Return loss (dB)
51 to 102	6
102 to 3 072	8

### 8.2.4 Impedance towards ground of the output port

The impedance towards ground of output port shall exceed the values given by:

- 10 Hz <  $f \leq$  500 kHz: 1 000  $\Omega$ ;
- 500 kHz <  $f \leq$  1 MHz; falling linear from 1 000  $\Omega$  with 6 dB/octave with a logarithmic frequency scale.

## 8.3 Specification at the input ports

### 8.3.1 Receiver sensitivity

The digital signal presented at the input port shall be as defined above but modified by the characteristic of the interconnecting pair. The attenuation of this pair shall be assumed to follow a  $\sqrt{f}$  law and the loss at a frequency of 1 024 kHz shall be in the range 0 dB to 6 dB. This attenuation shall take into account any losses incurred by the presence of a digital distribution frame between the equipment.

### 8.3.2 Return loss at the input port

The return loss at the input port with respect to the nominal impedance of 120  $\Omega$  shall be greater or equal than the values of table 13.

**Table 13: Return loss at the input port**

Frequency range (kHz)	Return loss (dB)
51 to 102	12
102 to 2 048	18
2 048 to 3 072	14

### 8.3.3 Input port immunity against reflections

To ensure adequate immunity against signal reflections that can arise at the interface due to impedance irregularities at digital distribution frames and at digital output ports, input ports shall meet the following requirement:

A nominal aggregate signal, encoded into HDB3 and having a pulse shape as defined in the pulse mask shall have added to it an interfering signal with the same pulse shape as the wanted signal. The interfering signal shall have a bit rate within the limits specified in this ETS, but shall not be synchronous with the wanted signal. The interfering signal shall be combined with the wanted signal in a combining network, with an overall zero loss in the signal path and with the nominal impedance 120  $\Omega$ , to give a signal-to-interference ratio of 18 dB. The binary content of the interfering signal shall comply with ITU-T Recommendation O.151 [3] ( $2^{15}-1$  bit period). No errors shall result when the combined signal, attenuated by up to the maximum specified interconnecting cable loss, is applied with both polarities to the input port.

NOTE: A receiver implementation providing an adaptive rather than a fixed threshold is considered to be more robust against reflections and should therefore be preferred.

**8.3.4 Tolerable longitudinal voltage**

For minimum tolerance to longitudinal voltage at input port the receiver shall operate without errors with any valid input signal in the presence of a longitudinal voltage  $V_L$ .

$V_L = 2 V_{rms}$  over the frequency range 10 Hz to 30 MHz.

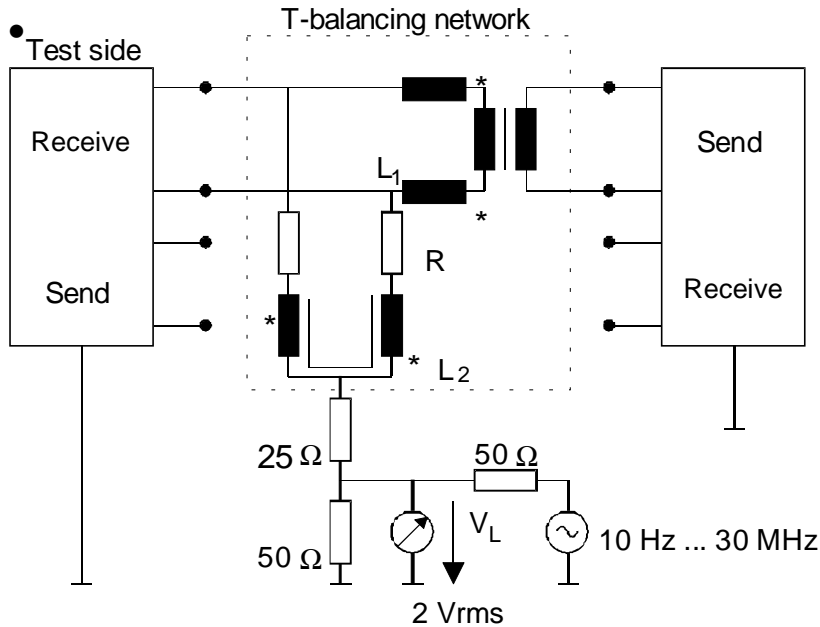

$L_1 = 2 \times 38 \text{ mH}$   
 $L_2 = 2 \times 38 \text{ mH}$   
 $R = 2 \times 200 \text{ ohms}$

NOTE: The inherent longitudinal voltage conversion of the T-balancing network should be 20 dB better than required at the interface under test (CCITT Recommendation O.9, see bibliography).

**Figure 9: Test of tolerance to longitudinal voltage**

**8.3.5 Impedance towards ground of the input port**

The impedance towards ground of input shall exceed the values given by:

- 10 Hz <  $f \leq$  500 kHz: 1 000  $\Omega$ .
- 500 kHz <  $f \leq$  1 MHz: falling linear from 1 000  $\Omega$  with 6 dB/octave with a logarithmic frequency scale.

**8.4 Jitter**

**8.4.1 General considerations**

The jitter specifications take into account subscriber configurations with only one access and configurations with multiple accesses.

In the case of one access only, this may be to a network with transmission systems of either high Q or low Q clock recovery circuits.

In the case of multiple accesses, all access transmission systems may be of the same kind (either low Q or high Q clock recovery circuits) or they may be of different kinds (some with high Q and some with low Q clock recovery circuit).

Examples of single and multiple accesses are given in figure 10.

The reference signal for the jitter measurement shall be derived from the network clock. The nominal value for one UI is 488 ns.

The input and output jitter requirements shall be met with an ideal input signal and with an input signal having an attenuation in the range defined in subclause 8.3.1.

The input and output jitter requirements shall be met at any bit rate to which a TE/NT2 is able to synchronize, according to subclause 5.8.

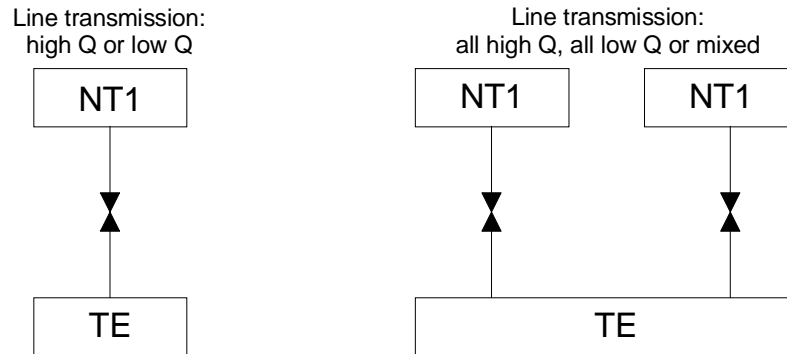

Figure 10: Examples of single and multiple access

#### 8.4.2 Minimum tolerance to jitter and wander at TE inputs

##### 8.4.2.1 Tolerable input jitter when connected at T, S or S/T reference point

The 2 048 kbit/s input of a TE shall tolerate sinusoidal input jitter/wander in accordance with table 14 and figure 11 without producing bit errors or losing frame alignment. A TE with multiple accesses shall respect the worst case phase deviation between TE inputs of maximum 41 UI.

NOTE : Jitter/wander is Maximum Time Interval Error (MTIE) as defined in CCITT Recommendation G.811 and specified in CCITT Recommendation G.823, paragraph 2.2. In practice, this jitter/wander is superimposed upon a timing signal which is reasonably stable (c.f. CCITT Recommendation O.171). In the worst case the phase deviation of a TE input from another TE input, in the multiple access configuration, can at maximum be twice the value  $A_0$  given in table 14.

Table 14: Minimum tolerable jitter and wander at the TE input

$A_0$	$A_1$	$A_2$	$f_0$	$f_1$	$f_2$	$f_3$	$f_4$
20,5 UI	1,0 UI	0,2 UI	$12 \times 10^{-6}$ Hz	20 Hz	3,6 kHz	18 kHz	100 kHz

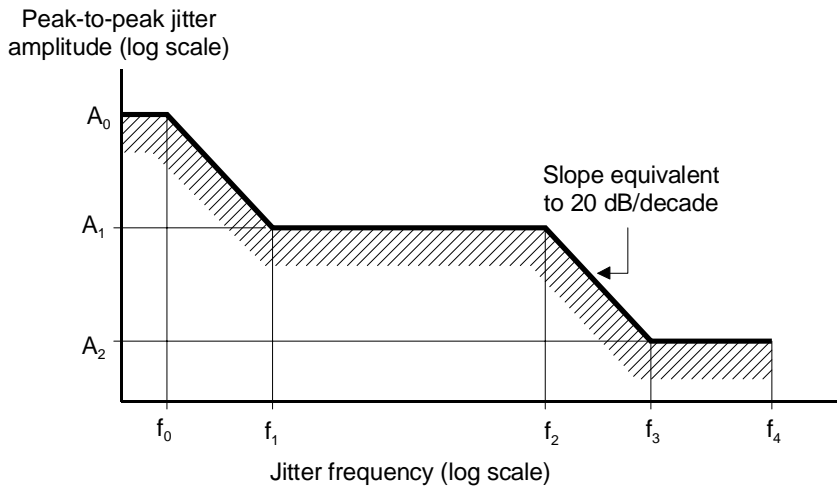

Figure 11: Minimum tolerable jitter and wander at the TE input

8.4.2.2 Tolerable input jitter when connected to leased lines

The input of a TE designed for PTNX interconnection shall tolerate sinusoidal input jitter/wander in accordance with table 15 and figure 11 without producing bit errors or losing frame alignment. A TE with multiple accesses shall respect the worst case phase deviation between TE inputs of maximum 41 UI.

NOTE: Jitter/wander is Maximum Time Interval Error (MTIE) as defined in CCITT Recommendation G.811 and specified in CCITT Recommendation G.823, paragraph 2.2. In practice, this jitter/wander is superimposed upon a timing signal which is reasonably stable (see CCITT Recommendation O.171). In the worst case the phase deviation of a TE input from another TE input, in the multiple access configuration, can at maximum be twice the value  $A_0$  given in the table 15.

Table 15: Minimum tolerable jitter and wander at TE/NT2 for interfaces designed for PTNX interconnections

$A_0$	$A_1$	$A_2$	$f_0$	$f_1$	$f_2$	$f_3$	$f_4$
20,5 UI	1,5 UI	0,2 UI	$12 \times 10^{-6}$ Hz	20 Hz	2,4 kHz	18 kHz	100 kHz

8.4.3 TE and NT2 output jitter at interface I<sub>A</sub>

Three cases shall be considered.

8.4.3.1 TE and NT2 with only one UNI.

The peak-to-peak output jitter shall meet the limits of table 16 when measured with a bandpass filter having a high pass of first order (slope of 20 dB/decade) with cut-off frequencies as defined below. At the input the signal shall be provided with the tolerable input jitter specified in subclause 8.4.2, and with tolerable frequency deviation during measurement. Tests shall be made with NOFs as well as AIS.

Table 16: Output jitter for TE with one UNI

Measurement filter bandwidth		Output jitter
Lower cut-off (high pass)	Upper cut-off (low pass)	UI peak-to-peak (maximum)
20 Hz	100 kHz	1,1 UI
400 Hz	100 kHz	0,11 UI

8.4.3.2 TE and NT2 with more than one UNI to the same public ISDN

The peak-to-peak output jitter shall meet the limits of table 17 when measured with a bandpass filter having a high pass of first order (slope of 20 dB/decade) with cut-off frequencies as defined below. At the

input the signal shall be provided with the tolerable input jitter specified in subclause 8.4.2.1, and with tolerable frequency deviation during measurement. Tests shall be made with Normal Operational Frames (NOFs).

**Table 17: Output jitter for TE with multiple UNIs**

Measurement filter bandwidth		Output jitter
Lower cut-off (high pass)	Upper cut-off (low pass)	UI peak-to-peak (maximum)
4 Hz	100 kHz	1,1 UI
40 Hz	100 kHz	0,11 UI

Equipment with more than one interface using timing selection method (only one input, being in operational state, is used to synchronize the equipment clock at a point in time) may be considered as an equipment with one interface. In this case it shall meet the requirements of subclause 8.4.3.1 also during switch over to another interface (signal at input supplying timing changes from NOF with nominal frequency to AIS with plus or minus 50 ppm from the nominal frequency while all other inputs still receive NOF with the nominal frequency). The signals provided to the inputs shall carry tolerable jitter and may have deviation of bit-phase up to 0,5 UI.

#### 8.4.3.3 TE and NT2 designed for interconnection via leased lines

For a PTNX acting as a synchronization master the output jitter at interface IB shall be in accordance with the limits given in subclause 8.4.3.1.

The output jitter at interface I<sub>A</sub> shall be in accordance with the requirements given in subclause 8.4.3.2 with tolerable input jitter as specified in subclause 8.4.2.2.

#### 8.4.4 Minimum tolerance to jitter and wander at NT inputs

##### 8.4.4.1 Tolerable input jitter at T reference point

The input of an NT shall tolerate input jitter being the sum of two band limited components as defined in table 18 without producing bit errors or losing frame alignment. The generation of this two band signal is illustrated in figure 12.

**Table 18: Input jitter for NT1**

Measurement filter bandwidth		Band pass filter for measurement of input jitter	Input jitter measured by band pass filter
Lower cut-off (high pass)	Upper cut-off (low pass)	(lower cut-off first order)	UI peak-to-peak (maximum)
Only low pass	20 Hz	20 Hz to 100 kHz	1,1 UI
400 Hz	100 kHz	400 Hz to 100 kHz	0,11 UI

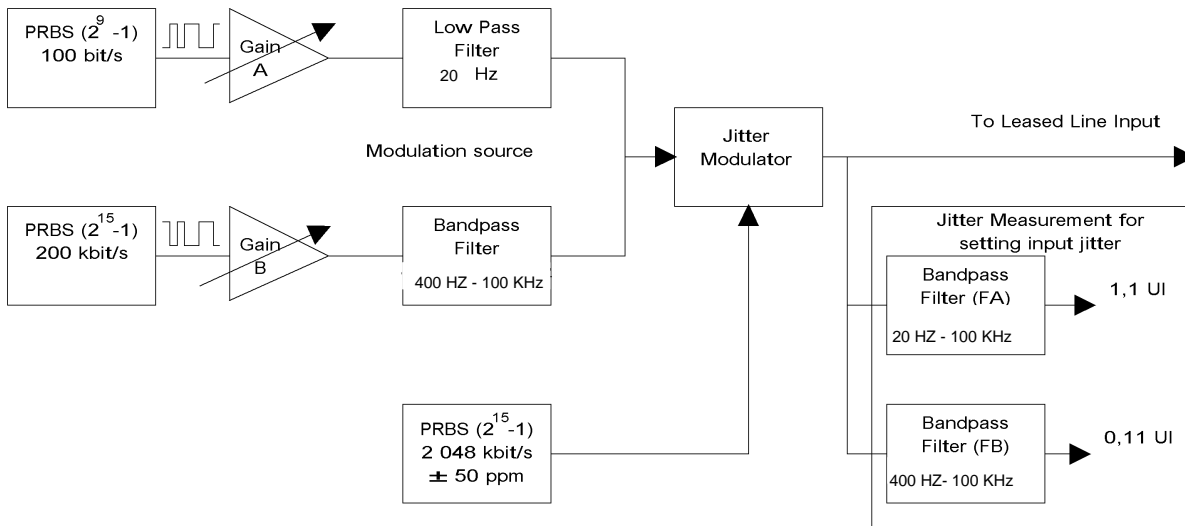

NOTE: The filter gains to determine the jitter levels are set individually. Filter FA is used when setting the value of A, with signal B disconnected. Filter FB is used when setting the value of B, with signal A disconnected.

Figure 12: Input jitter generation

8.4.4.2 Tolerable input jitter at leased lines input

The tolerable input jitter for 2 048 kbit/s unstructured and structured leased lines is specified in ETS 300 247 [17] and ETS 300 419 [18] respectively.

9 Power feeding

The power feeding requirements of this ETS are based on a single access NT1. A power source able to feed more than one NT1 (via a common pair of wires in the installation) shall meet the requirements at each individual power feeding interface at the same point in time.

Customer access arrangements not using individual NT1 (e.g. higher order multiplexer system with multiplexed primary rate accesses) are outside the scope of this ETS and therefore subject for individual power feeding arrangements between customer and network provider.

9.1 Provision of power

The power shall be provided by using a separate pair of wires to those used for transmission.

The provision of power to the NT1 via the user network interface shall be made either:

- by the user;
- by the network provider via to the mains electric supply in the customer premises.

In the case when the power is supplied by the user then the following two options are available to the user to provide the power supply:

- as an integral part of the TE; or
- physically separated from the TE as an individual power supply unit.

9.2 Power available at the NT

The power available at the input of the NT1 via the UNI when provided, shall be at least 10 W.



### 9.3 Feeding voltage

The feeding voltage at the input of the NT1 shall be in the range of -20 to -57 V relative to ground.

### 9.4 Safety requirements

In principle, safety requirements are outside the scope of this ETS. However, in order to harmonize power source and sink requirements the following is required:

- a) the power source shall be protected against short circuits and overload;
- b) the power sink of NT1 shall not be damaged by an interchange of wires.

With respect to the feeding interface of the power source, which is regarded as a touchable part in the sense of EN 60950 [4], the requirements are defined in ETS 300 046-2 [10] and ETS 300 046-4 [12].

## Annex A (normative): Application of ETS 300 011-1 to the S reference point

### A.1 Scope

The scope of this annex is the application of this ETS to the primary rate access interface at an S reference point, as provided by a PTNX to its terminals (see figure A.1).

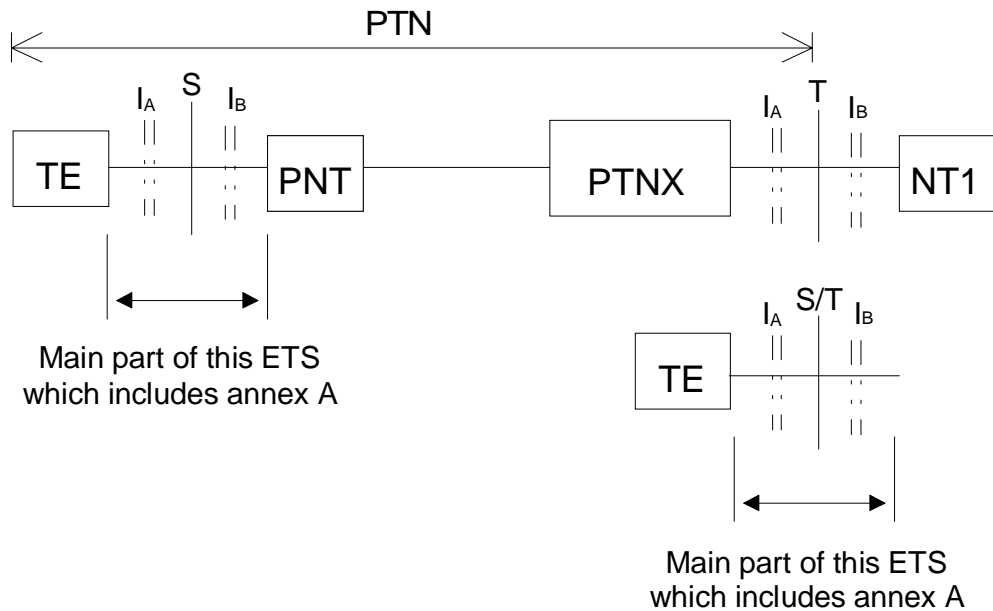

S, S/T, T = Reference points.

NOTE: The PNT may be a separate equipment or incorporated in the PTNX.

**Figure A.1: Application of this ETS at various reference points**

### A.2 Requirements

#### A.2.1 Timing considerations

In a condition where the Private Telecommunications Network (PTN) is not synchronized by a high precision master clock (e.g. of the public ISDN), the frequency deviation of its free running clock shall not exceed the limit of a TE designed to act as a master (see subclause 5.8).

#### A.2.2 Jitter, general considerations

The PTN shall comply with the jitter characteristics as specified in subclause 8.4.2. A PTN deriving its timing from the public ISDN shall meet the jitter characteristics specified for a TE with multiple accesses (see subclause 8.4.3.2).

#### A.2.3 Frame alignment and CRC-4 procedures

Operation without CRC-4 procedure can be required, and shall be restricted, to cover interworking situations. Interfaces for the S reference point following this ETS, but, in addition, designed for interworking with equipment not supporting CRC-4 procedures, shall provide a CRC-DISABLE management function which allows disabling of the CRC-4 procedure.

When the CRC-DISABLE function is activated, the CRC multiframe alignment procedure shall be inhibited and the CRC error reporting function shall be fixed in a way that the CRC error report primitive "Local CRC-E1" would always indicate to the management entity that no CRC error had occurred.

When the CRC-DISABLE function is activated, Bit 1 of time slot 0 shall always be set to ONE.

### **A.3 Interface wiring**

The TE can be connected to the PTN either by permanent wiring or via connectors (see subclause 4.4). The connection cords shall be considered part of the wiring which shall consist of two twisted and commonly or separately shielded pairs.

### **A.4 Loopbacks required at S reference point**

Loopback 4, as defined in annex B, shall be implemented.

It is to be noted that there is currently no protocol defined in the D-channel protocol to control loopback 4 remotely by a PTNX. In addition, to control loopback 4 from a remote point (e.g. a remote maintenance server or a remote user), a protocol mechanism is to be specified as applicable between the remote point and the TE or the remote point and the relevant PTNX.

## Annex B (normative): Characteristics of loopbacks

### B.1 Introduction

ETR 001 [9] defines loopbacks used in the maintenance of the customer installation and subscriber access, respectively. This information is repeated here to aid in understanding the layer 1 maintenance capabilities that may affect the UNI.

### B.2 Characteristics of loopback at the network side

**Table 19: Characteristics of the loopback 2 for primary rate customer access**

Loop-back	Location	Channel (s) looped back	Loop back type	Control point	Control mechanism	Application	Implementation
2	in NT1 as near as possible to T towards ET (see note 2)	Complete loopback	Complete transparent (see note 3)	FFS	Layer 1 signals (see note 1) (see note 2)	Failure localization + verification	Optional
NOTE 1:	These layer 1 signals may not be in the frame signals. They may be line signals.						
NOTE 2:	In the case of using existing digital transmission systems, a manual loopback may be put in place of the loopback 2, this manual loopback may be implemented between NT 2 and NT 1 and controlled by the user on demand of the network staff.						
NOTE 3:	The network shall indicate the loss of layer 1 capability of the access during operation of the loopback by transmission of RAI towards the TE. In case of network option 2 applied in the NT1 CRC error information towards the TE shall be suppressed (set E-bits towards TE to 1).						

### B.3 Characteristics of loopbacks for primary rate customer installations

Table 20: Characteristics of loopbacks for primary rate customer installations

Loop-back	Location	Channel (s) looped	Loop back type	Control point	Control mechanism	Implementation
B2	Inside the NT2 at the network side	These loopbacks are optional in the TE.				
A	Inside the TE	When used (e.g. as part of an internal test), the TE should not transmit signal which interferes with the network (i.e. it shall not send operational frames).				
3	In NT2 as near as possible to reference point S towards the T-reference point	30 B&D or 31B channels	complete transparent or non transparent (see note to ETR 001 [9])	NT2 NT2	Local maintenance Layer 3 messages in D-channel or inband signal in B-channel (see note 1)	(see note 2) optional
4	inside the TE	B1 .. B30 (see note 3)	partial, transparent or non-transparent	(see note 4)	Layer 3 messages in D-channel	(see note 5) optional
NOTE 1:	Activation/deactivation of loopback 3 may be requested from a maintenance service provider. The test, however, is performed by the NT2.					
NOTE 2:	From a technical viewpoint, it is desirable that loopback 3 always be implemented (though it is not mandatory) and so the design of protocols for loopback control should include the operation of loopback 3.					
NOTE 3:	B-channel loopbacks are controlled by separate control signals. However more than one loopback may be applied at the same time.					
NOTE 4:	Control by NT2, local exchange, remote maintenance server or remote user.					
NOTE 5:	The implementation status refers to the equipment for connection to the interface at the T reference point. For equipment for connection to the interface at the S reference point the implementation shall be mandatory according to clause A.4 of this ETS.					

**Annex C (informative): Overview of technical changes to edition 1**

This annex gives a list of all technical changes and their reason. For clarity the modified requirement is given first, followed by the old requirement.

N°	Edition 2	Edition 1	Difference
1	subclause 5.8	table 1/5.3	A TE which is designed to be connected to the T reference point only or a TE with a free running clock accuracy better than $\pm 1$ ppm, shall be able to synchronize at the nominal bit rate $\pm 1$ ppm. A TE which is designed to be connected to the T reference point only, shall be able to synchronize at the nominal bit rate $\pm 5$ ppm. Reason: Alignment with TBR 3.
2	6.3	table 1/3.4.3	Network option 1 is only applicable for PTNX interconnection using unstructured leased lines because this option is not specified in ETS 300 233 [16]. There is no option in localization of CRC-4 processing in the access digital section.
3	6.4	table 1/3.4.4	All references to network option 1 and 2 are deleted because there is not option in the access. In addition, the layer 1 states of the network side do not apply for PTNX interconnection.
4	6.5, table 6	table 1/3.4.5	Notes 1 and 2 are modified to be aligned with the change of subclauses 6.3 and 6.4.
5	7.2.2	table 1/5.9.2.2	Modified title in order to reflect that CRC-4 is always processed in public ISDN accesses and that CRC-4 may be processed in leased lines.
6	7.2.2.1	table 1/5.9.2.2.1	Modified in order to show that a transmission link without CRC-4 processing could only appear for PTNX interconnection.
7	7.2.2.2	table 1/5.9.2.2.2	Modified in order to reflect that CRC-4 is always processed in public ISDN accesses and that CRC-4 may be processed in leased lines.
	8.2.3	---	Output return loss according ETS 300 166 [15] is added.
	8.2.4	table 1/5.7	Impedance towards ground is modified according TBR 4.
8	8.4.2.2	A.3.2	Requirement is moved from old annex A which is deleted.
9	8.4.3.3	A.3.3	Requirement is moved from old annex A which is deleted. In addition, the 2 requirements for output jitter are assigned to interface $I_A$ and $I_B$ .
10	8.4.3.3	A.3.3, table A.2	The maximum output jitter in the bandwidth 4 Hz - 100 kHz is reduced from 1,6 UI to 1,1 UI. Reason: Alignment to leased line ETSSs.
	8.4.4	---	Added to get a consistency set of requirements. This subclause specifies the maximum TE output jitter as tolerable input jitter for NT inputs.
	8.4.4.1	---	New test method is derived from ETSI leased line standards.
11	9.2	table 1/8.2	The minimum power at NT is increased from 7 W to 10 W. Reason: To enable the use of HDSL.
12	clause B.3	D.3, table D.2	Layer 3 is defined as the control mechanism for loopback 4. Up to now such a control mechanism is not specified in layer 3 ETSSs. Should the specified control mechanism be replace by "undefined"?
13	---	table 1/5.2.1	Requirement on number of bit per time slot is deleted to be aligned with TBR 4.

## Annex D (informative): Bibliography

- **ECMA 104:** "Physical Layer at the Primary Rate Access Interface between Data Processing Equipment and Private Switching Networks".
- **CCITT Recommendation I.431 (1993):** "Primary rate user-network interface - Layer 1 specification".
- **CCITT Recommendation G.703 (1991):** "Physical/electrical characteristics of hierarchical interfaces".
- **CCITT Recommendation G.704 (1995):** "Synchronous frame structures used at 1544, 6312, 2048, 8488 and 44 736 kbit/s hierarchical levels".
- **CCITT Recommendation G.706 (1991):** "Frame alignment and cyclic redundancy check (CRC) procedures relating to basic frame structures defined in Recommendation G.704".
- **CCITT Recommendation G.811 (1988):** "Timing requirements at the outputs of primary reference clocks suitable for plesiochronous operation of international digital links".
- **CCITT Recommendation G.823 (1993):** "The control of jitter and wander within digital networks which are based on the 2 048 kbit/s hierarchy".
- **CCITT Recommendation I.432 (1993):** "B-ISDN user-network interface - Physical layer specification".
- **CCITT Recommendation I.604 (1988):** "Application of maintenance principles to ISDN primary rate accesses".
- **CCITT Recommendation Q.931 (1993):** "Digital Subscriber Signalling System No. 1 (DSS 1) - ISDN user-network interface layer 3 specification for basic call control".
- **CCITT Recommendation O.9 (1988):** "Measuring arrangements to assess the degree of unbalance about earth".
- **CCITT Recommendation O.171 (1992):** "Timing jitter measuring equipment for digital systems".
- **ETS 300 102-1:** "Integrated Services Digital Network (ISDN); User-network interface layer 3 Specifications for basic call control".

## History

Document history			
April 1996	First Edition		
November 1996	Public Enquiry	PE 117:	1996-11-04 to 1997-02-28
December 1997	Vote	V 9809:	1997-12-30 to 1998-02-27