

ETSI/TC SMG

Updated by : ETSI/PT12

Date : February 1992

Title : **ETSI TECHNICAL SPECIFICATION GSM 11.40
SYSTEM SIMULATOR SPECIFICATION**

(Part 2 of Draft NET 10)

Version 3.5.0

List of contents:

- Detailed table of contents
- 1. General
- 2. Functional requirements
- 3. Design requirements
- 4. Verifying the System Simulator
- Appendices 1 to 3

Original language: English

Number of pages : 46

DETAILED TABLE OF CONTENTS

1.	GENERAL
1.1	Scope
1.2	Terminology
2.	FUNCTIONAL REQUIREMENTS
2.1	General
2.2	The simulated radio network
2.2.1	Transmission capabilities
2.2.1.1	Standard test signals
2.2.2	Reception capabilities
2.3	MS-BSS interface testing requirements
2.3.1	Physical interface
2.3.1.1	Activation of MS type testing functions
2.3.1.2	Channel parameters and frequency hopping
2.3.1.3	RF power control
2.3.1.4	Ciphering and deciphering
2.3.1.5	Downlink burst generation
2.3.1.6	Uplink error indication
2.3.2	Layer 2
2.3.3	Layer 3
2.3.3.1	General
2.3.3.2	Normal downlink handling
2.3.3.3	Extended downlink handling
2.3.3.4	Normal uplink handling
2.3.3.5	Extended uplink handling
2.3.3.6	Handling of Timers
2.3.3.7	Special signalling features
2.3.4	Testing of support for services
2.4	Speech codec testing requirements
2.5	Support for testing of user's data services
2.5.1	General
2.5.2	Types of data services
2.5.3	Support for testing of bearer services
2.5.4	Support for testing of non-transparent services
2.5.5	Support for testing of the electrical characteristics of the MS's user's data interfaces
2.5.6	Support for testing of teleservices
2.5.7	Support for testing of terminal adapters
2.6	Management of MS and subscriber data
2.7	Management of authentication
2.7.1	Requirements of the System Simulator
2.7.2	Definition of the Test Algorithm for authentication
2.8	SIM/ME interface testing requirements
2.9	Definitions of transmit and receive times
2.10	Man-machine interface
2.10.1	Operative command functions of the system simulator
2.10.1.1	General system control commands
2.10.1.2	Direct mode commands
2.10.1.3	Edit mode command
2.10.2	Functions within test cases
2.10.3	Determining the outcome of a tests
2.10.4	Output information and format
2.10.4.1	Test report
2.10.4.2	Indication levels
2.10.4.3	Display of MS indicators

- 3. DESIGN REQUIREMENTS
 - 3.1. General
 - 3.2 MS test port specification
 - 3.2.1 RF test ports
 - 3.2.1.1 Mobile station antenna connection
 - 3.2.1.2 Substitution antennas
 - 3.2.1.3 Interfering field antenna
 - 3.2.1.4 Antenna coupling device
 - 3.2.2 MS audio test ports
 - 3.2.2.1 LRGP, artificial mouth and artificial ear
 - 3.2.2.2 Digital Audio Interface (DAI)
 - 3.2.3 User data interfaces in the MS
 - 3.2.4 MS power supply interface
 - 3.2.5 Electrical MS man-machine interface (EMMI)
 - 3.3 RF measurement capabilities
 - 3.3.1 RF power measurements
 - 3.3.1.1 Power versus time measurements
 - 3.3.1.2 Wide band selective power measurements
 - 3.3.1.3 In band selective power measurement
 - 3.3.2 Phase trajectory and frequency error measurements
 - 3.3.3 RF delay measurements relative to nominal times
 - 3.4 RF test signals
 - 3.4.1 The wanted signal or Traffic Channel of the serving cell
 - 3.4.2 The first interfering signal or Traffic channel of the First adjacent cell
 - 3.4.3 The Second interfering signal
 - 3.4.4 BCCH carriers of serving and adjacent cell
 - 3.4.5 The wide frequency range signal
 - 3.4.6 The multipath fading function
 - 3.4.7 Combinations of test signals
 - 3.5 Audio test signals
 - 3.5.1 Analog single test tone
 - 3.5.2 Digital 8 bit PCM test signal
 - 3.5.2.1 Digital 8 bit PCM single test tone
 - 3.5.2.2 Decoder output value 1
 - 3.5.2.3 Digital 8 bit PCM band limited noise test signal
 - 3.6 Audio measurement capabilities
 - 3.6.1 General
 - 3.6.2 Sound level/pressure measured at the Ear Reference Point
 - 3.6.2.1 One-third octave measurements
 - 3.6.2.2 A-weighted measurements
 - 3.6.3 Distortion
 - 3.6.4 DAI level measurements
 - 3.6.5 Delay measurements
 - 3.6.5.1 Delay measurement between Um and DAI
 - 3.6.5.2 Delay measurement between DAI and acoustic interface
 - 3.6.6 AF frequency counter
 - 3.7 Sim simulator
 - 3.8 The system simulator control system
 - 3.9 Environmental requirements
 - 3.10 Calibration of the system simulator
 - 3.11 Transmitter and receiver construction in the SS
- 4. VERIFYING THE SYSTEM SIMULATOR

Appendix 1: Examples of signalling procedures

Appendix 2: Test Configurations

Appendix 3: Time measurement uncertainty for the power time mask

1. GENERAL

Notes:

- 1) The present specification of the System Simulator only supports testing of equipment operating in the 900 MHz GSM-band.
- 2) The description of the SS for the support of testing of data services needs further elaboration.

1.1 SCOPE

The System Simulator (SS) is an equipment or assembly of equipments which enables the tests detailed in the modules "Aspect II" and "Aspect III" of GSM 11.10 to be conducted. It simulates the network side of the MS-BSS interface as part of its testing function.

1.2 TERMINOLOGY

For definitions and abbreviations see GSM 11.10.

2. FUNCTIONAL REQUIREMENTS

2.1 GENERAL

The system simulator shall perform the tests of the Mobile Station described in GSM 11.10.

The system simulator has to simulate the network side of the MS-BSS interface as seen by the MS.

The system simulator does not include environmental test equipment such as climatic chambers, anechoic shielded chamber, vibration or rotation devices.

The System Simulator is required to take account of losses and effects of test apparatus connected externally for the purpose of testing, adjusting the test results accordingly.

2.2 THE SIMULATED RADIO NETWORK

The SS shall be able to simulate a radio environment consisting of up to 8 cells. Two of these cells shall be simulated with 1 BCCH and 1 physical channel each. 6 of the cells shall be simulated by transmitting 6 independent BCCHs. It shall be possible to transmit simultaneously all 8 BCCHs and the downlink of the 2 physical channels. The SS shall be able to receive signals from the MS on the 2 physical channels and 1 RACH.

Examples of signalling procedures leading to the above requirements on the system simulator are in Appendix 1 of this part. Some possible test configurations are given in Appendix 2 of this part.

2.2.1 Transmission capabilities

The SS shall simulate two cells with the following functions in each:

- Frequency hopping, see section 2.3.1.2
- Fading, see 3.4.6, on serving cell and first interferer, see 3.4.7
- Adjustable RF output power
- Adjustable delay, see 2.3.1.5
- Adjustable multiframe structure (T1, T2, T3), see 2.3.1.2
- 1 BCCH channel with power ramping
- 1 physical channel used as either PCH, AGCH, SDCCH, TCH (SACCH, FACCH) or as either the wanted signal or the first interferer.

The RF requirements for the 2 cells are given in section 3.4.

The SS shall in addition transmit the BCCH of 6 independent cells with the following characteristics:

- Adjustable RF output power;
- Adjustable delay;
- Adjustable multiframe structure;
- Non correlated frequencies/timing.

The RF requirements for the 6 BCCHs are given in section 3.4.4/3.4.7. It is acceptable that these 6 BCCHs transmit continuously without power ramping.

For measurements of the MS at least the following test signals are to be transmitted by the SS, see section 3.4:

- The Wanted signal with and without fading;
- The First interfering signal with and without fading;
- The Second interfering signal;
- Signal for substitution of spurious signal.

2.2.1.1 Standard test signals

The following test signals shall be generated by the test equipment. The Cx signals represent the wanted signals and the Ix signals represent the unwanted signals.

- Signal C0 Unmodulated continuous carrier;
- Signal C1 A standard GSM signal with the modulation derived by applying a data reversals signal to the input of a channel coder. The channel coder will depend on the test and the cypher mode shall be selectable by the test method. When using this signal in the non hopping mode, the unused seven time slots shall also contain dummy bursts, with power levels variable with respect to the used timeslot, see also 2.3.1.3.
- Signal I0 Unmodulated continuous carrier;
- Signal I1 A GMSK modulated carrier following the structure of the GSM signals, but with all modulating bits (including the midamble period) derived directly from a random or pseudo random data stream.
- Signal I2 A standard GSM signal with valid midamble, different from C1. The data bits (including bits 58 and 59) shall be derived from a random or pseudo random data stream.

2.2.2 Reception capabilities

The SS shall be able to receive simultaneously on at least two physical channels with the following functions in each:

- Frequency hopping
- Adjustable multiframe structure (T1,T2,T3)
- Reception on the CCCH (RACH), SDCCH, TCH (SACCH, FACCH).

The receiving function shall be interconnected to the relevant transmission function.

The SS shall in addition have the following RF measurement capabilities, see section 3.3:

- Average RF power
- Time mask power measurements
- Selective RF power
- Phase trajectory and frequency error
- RF delay.

The receiver should be capable of performing the tests as specified in GSM 11.10 without the addition of bit errors in excess of 1 in 10^7 due to the receiver performance when operated with a MS which meets the transmitter requirements of GSM 05.05.

Note: This requirement is based on a minimum BER measurement of 10^{-5} .

Note: For the test of cell selection/reselection (GSM 11.10/II.6), one of the following additional receive functions is required:

- a wide band receive function, such as for instance a spectrum analyzer (this is the preferred solution), or
- an additional receive function for the GSM type of channel.

2.3 MS-BSS INTERFACE TESTING REQUIREMENTS

2.3.1 Physical interface

The SS shall support the full range of transmit and receive frequencies of a base station system.

The SS shall support all traffic channels for speech and data and all control channels.

The frequency bands, channels and channel numbering are according to the GSM 05 series of recommendations.

Note: In the future, the System Simulator may additionally utilize frequencies outside the GSM band (see also GSM 05.05). Consequently these frequencies may be included in this section later.

2.3.1.1 Activation of MS type testing functions

It shall be possible to activate special type testing functions in the MS, defined in GSM 11.10/III.1.

2.3.1.2 Channel parameters and frequency hopping

It shall be possible to assign parameter values in the SS for channel definition and assignment for the two simulated BSS and the BCCHs of the adjacent cells independently.

For each logical channel, except the BCCH + PCH + AGCH, the System Simulator shall be able to switch to any frequency in the GSM band allocated to the MS under test on a frame per frame basis.

The detailed description of the frequency hopping scheme is given in GSM 05.02.

The parameters of the FH scheme shall be selectable in the SS.

2.3.1.3 RF power control

RF power control functions are optional in GSM Base Station System according to GSM 05.08 and shall be simulated by the System Simulator. The SS shall be able to switch from any power level to any other power level within the range of 30 dB on a timeslot per timeslot basis. This dynamic switching requirement only exist for a number of tests, using only a single physical channel.

2.3.1.4 Encryption and decryption

The SS shall start and synchronize ciphering and deciphering according to GSM 03.20. The bitstreams shall be generated by algorithm A5 using the encryption key Kc.

2.3.1.5 Downlink burst generation

It shall be possible to generate all types of bursts and to send such bursts according to the test description for all simulated GSM channels. It shall also be possible to omit any burst or group of bursts.

The contents of a burst can be defined in the following ways:

- By using default parameters from Layers 2 and 3;
- By entering new parameters for Layers 2 and 3.

It shall be possible to delay the transmission of bursts from 0 to 216 bit periods in steps of 1/4 bit periods for all modulated RF test signals.

2.3.1.6 Uplink error indication

The SS shall on operator request indicate bit errors in the signal received by the SS before and after error correction. The Bad Frame Indication (BFI) as sent by the MS shall be recorded and indicated.

The received bit stream in all frames and in non-erased frames shall be compared with the expected (looped or predicted) bit stream and the detected bit errors shown with position indicated.

It shall be possible to define an indication of bit errors to apply to the whole or part(s) of a speech frame.

The detected errors shall be presented in any or all of the following ways:

- frame erasure ratio
- BFI occurrence
- bit error ratio
- residual bit error ratio
- detected bit errors in received midamble.

The SS shall report any error correction performed by its channel decoder.

2.3.2 Layer 2

The SS shall implement the Layer 2 functions for BSS described in the GSM 04 series of recommendations. In addition it shall support all functions required for the tests in GSM 11.10/II.5.2 e.g.:

- ignore a specified number of frames sent by the MS;
- wait for a specific Layer 2 frame sent by the MS;
- send a Layer 2 frame provided by the test script to the MS replacing the frame which would be sent by the Layer 2 entity normally.

2.3.3 Layer 3

2.3.3.1 General

The SS shall implement the Layer 3 functions for BSS described in the GSM 04 series of recommendations. In addition it shall support all functions required for the tests in GSM 11.10/II.5.3.

2.3.3.2 Normal downlink handling

On the downlink, the SS shall simulate all signalling normally performed by the BCCH/CCCH of 8 cells with additional TCH/DCCH/ACCH in two cells. The actual configuration of the network differs from test to test. Most parameters have default and fixed values during the tests but they shall still be variable in the SS for each cell individually.

2.3.3.3 Extended downlink handling

In two cells, the SS shall be able to send Layer 3 messages with erroneous or out of range values in any part of the information elements in the message. It shall be able to, in the actual handling of a specific procedure, add additional messages of any kind, within any frame. It shall also be able to omit one or several messages or information elements within a message normally included in a Layer 3 procedure. Within a message it shall be possible to alter the order of different information elements and/or duplicate information elements.

2.3.3.4 Normal uplink handling

In two cells, the SS shall be able to receive, decode, register and act upon messages normally sent by a MS operating in an environment consisting of 8 cells originating from one or several PLMNs.

2.3.3.5 Extended uplink handling

In two cells, the SS shall be able to receive, decode, register, react and report upon erroneous messages. This includes messages with faulty Protocol Discriminators, Message Type Identifiers, Parameter values and Information Element Identifiers. The SS shall be able to receive messages out of sequence, received at abnormal situations in procedures or out of timing. Within messages, information elements may be in the wrong order or duplicated.

2.3.3.6 Handling of Timers

The SS shall implement timers. If timer values are normally variable in a PLMN, they shall also be variable in the SS.

It shall be possible to delay the transmission of any messages until a specified event and/or time has arrived. This includes sending a message one or several times even though any timer value on either side of the interface forbids the transmission.

2.3.3.7 Special signalling features

The required signalling capabilities include:

- Handling of DTMF signalling
- Transmitting/receiving Short Messages in any mode of operation
- Introducing lower layer failures on any signalling link
- Handling of special test messages on the Um interface, not normally used by the network.
- Handling of two simultaneous half-rate calls.

2.3.4 Testing of support for services

The SS shall be capable to support testing of all the services that are listed in GSM 11.10/II.1:

- The capabilities to support testing shall be complete for those services for which testing is provided elsewhere in GSM 11.10.
- The capabilities to support testing of the other services may be limited, but shall at least enable call establishment and call clearing. This shall make it possible to verify that the MS refuses to set up a call for that service (example: packet mode).

2.4 SPEECH CODEC TESTING REQUIREMENTS

The following interfaces, conversion capabilities, and signal processing shall be available in the System Simulator for speech codec tests, see also sections 3.2.2, 3.5 and 3.6 and Appendix 2:

1. A 13 bit Digital Audio Interface (DAI) (104 kb/sec) input and output from and to the MS according to GSM 11.10/ III.1.4.
2. A facility to transmit speech test frames according to the GSM 06 series of recommendations via the air interface or the digital audio interface (GSM 11.10, section III.1).
3. A facility to receive speech test frames and compare against a reference pattern according to GSM 06.10 and 06.32, from the air interface or the digital audio interface.
4. Read/Write capabilities on IBM PC/AT*), MS/DOS**) diskettes of 1.44 Mbyte or RAM and ROM for comparison purposes of at least 1.44 Mbyte.
*) trademark of International Business Machines Corporation
**) trademark of Microsoft Corporation
5. A complete speech transcoder including encoding and decoding functions, according to GSM 06.10.
6. Handset for audio input/output in the SS with SLR and RLR requirements as for the MS handset.
7. Detection capabilities of noise update frames (SID-frames) according to GSM 06.12.
8. Capability to verify correct DTX handling of the MS, see GSM 11.10/II.13.

2.5 SUPPORT FOR TESTING OF USER'S DATA SERVICES

2.5.1 General

For a number of user's data services testing is described in GSM 11.10.

Note: The requirements on the SS in this section are preliminary.

The SS shall be able to set and verify the composition of the selected parameters (of GSM 04.08) and create the appropriate conditions.

The SS permits the testing of functions as implemented in the MS according to GSM 03.10.

The SS shall support all values for the attributes given in Table 4/GSM 03.10 for the radio interface connection element. The values of attributes for the "BSS-MSC" connection element are included in Table 4/GSM 03.10 "so far identified".

The SS shall fulfil the requirements given in Table 5/GSM 03.10 and Table 6/GSM 03.10 for the radio interface connection element.

2.5.2 Types of data services

The SS is capable of verifying the handling of all those user's data services by the MS, which are defined as being supported by the GSM system (GSM 02.02 and 02.03).

2.5.2.1 Local Terminal Emulator (LTE)

The SS shall provide a connection to the MS's user data connector and shall be capable of sending and receiving data for each of the services supported by GSM.

2.5.2.2 Interworking Function Emulator (IFE)

The SS shall emulate the network's data codec and the interworking function relevant for the user's data services.

2.5.2.3 Remote Terminal Emulator

The SS shall be capable of sending and receiving data according to the services being tested.

2.5.2.4 LTE, RTE and IWF

The LTE, RTE and IFE shall also support the testing of the specified types of call control signalling.

The LTE, RTE and IFE of the System Simulator shall fulfil the requirements of the Recs GSM 03.10, 04.22, 07.01, 07.02, 07.03, 07.04, 09.04, 09.05, 09.06 and 09.07.

2.5.3 Support for testing of bearer services

The SS shall support testing of bearer services (GSM 11.10/II.10) transparent and non-transparent, of the categories listed in Table 2/GSM 02.02.

Support for testing of the following functions shall be included:

1. synchronisation to the traffic channel
2. filtering of control information
3. terminal compatibility decision
4. rate adaptation
5. interchange circuit signalling mapping
6. call establishment signalling mapping.

2.5.4 Support for testing of non-transparent services

The SS shall support testing of the RLP and the L2R (COP and BOP).

2.5.5 Support for testing of the electrical characteristics of the MS's user's data interfaces

The SS shall support testing of the electrical characteristics of the user's data interfaces. Test facilities for the following interfaces shall be included:

- I.420 (S)
- V series (V.24, V.28)
- X series (V.11)
- Two wire analog interface, for use with fax group 3.

2.5.6 Support for testing of teleservices

The SS shall support testing of teleservices (GSM 11.10/II.11) of the categories listed in GSM 02.03/Table 2.

Support for testing of the following functions shall be included:

1. synchronisation to the traffic channel
2. filtering of control information
3. terminal compatibility decision
4. rate adaptation
5. interchange circuit signalling mapping
6. call establishment signalling mapping.

2.5.7 Support for testing of terminal adapters

The SS is not required to support testing of terminal adapters of a general application (e.g.: S -> R).

2.6 MANAGEMENT OF MS AND SUBSCRIBER DATA

The MS and subscriber data shall be selectable in the SS.

2.7 MANAGEMENT OF AUTHENTICATION

2.7.1 Requirements of the System Simulator

The SS shall be able to handle vectors of Kc, RAND, SRES in a similar way as the MSC/BSS entities. These vectors are used during certain test cases, when authentication and cyphering are required.

The SS shall:

- 1) incorporate a test algorithm for generating SRES and Kc from RAND and Ki which operates as described in section 2.7.2.;
- 2) be able to be programmed with values of Ki for use by the algorithm, corresponding to the value programmed into the SIM being used for the tests (This SIM may be the SIM Simulator comprising part of the SS.);
- 3) generate RAND to be used by the algorithm and also passed over the Um interface to the ME.

2.7.2 Definition of the Test Algorithm for Authentication

The following procedure employs bitwise modulo 2 addition ("XOR").

The following convention applies:

In all data transfers the most significant byte is the first byte to be sent; data is represented so that the left most bit is the most significant bit of the most significant byte.

Step 1:

XOR to the challenge RAND, a predefined number Ki, having the same bit length (128 bits) as RAND. The result RES1 of this is

$$RES1 = RAND \text{ XOR } Ki.$$

Step 2: (For the SIM Simulator only)

Since the calculation of RES1 will, in general, be much faster than the one carried out by an actual authentication algorithm, the introduction of a delay after the computation of RES1 is required. This can be achieved by executing the "XORing" of Ki a specified odd number (m) of times. This means calculating

$$\begin{aligned} RES_m &= (((RES1) \text{ XOR } Ki) \dots \text{ XOR } Ki) \\ &= (((RAND \text{ XOR } Ki) \text{ XOR } Ki) \dots \text{ XOR } Ki). \end{aligned}$$

Since m is odd,

$$RES_m = RAND \text{ XOR } Ki = RES1.$$

The value m shall be chosen to approximate the processing delay of a typical authentication algorithm, e.g. 50 ms. subject to m being odd.

Step 3:

The most significant 32 bits of RES1 form SRES. The next 64 bits of RES1 form Kc. The remaining 32 bits are not used.

2.8 SIM/ME INTERFACE TESTING REQUIREMENTS

The system simulator shall include a SIM simulator function to operate and test the SIM/ME interface in the ME.

The SIM simulator shall implement the functions of a SIM as described in GSM 02.17 and 11.11. In addition it shall support all functions required for the tests of the SIM/ME interface in GSM 11.10/II.8.

The SIM simulator shall also be able to emulate the SIM towards the ME, whereby parameters, defined to reside in a SIM, shall be selectable in the system simulator. Reading capabilities of parameters written by the ME onto the SIM is also required.

The Test Algorithm for authentication incorporated in the SIM Simulator shall operate as described in section 2.7.2.

2.9

DEFINITIONS OF TRANSMIT AND RECEIVE TIMES

The time a burst is received or transmitted is defined to be in the middle of the burst, i.e. transition from bit number BN74 to BN75 for all bursts except random access burst, the middle of which is the transition from BN48 to BN49. (see also GSM 11.10 section II.6.1.2)

The reception/transmission time of speech or data blocks or a signalling frame (L2 and L3) is defined to be the reception/transmission time of the last burst containing part of the block or frame.

The start of a Layer 2 or 3 frame is defined to be the time of the first burst containing part of the Layer 2 or 3 frame. (The time of a burst is defined to be in the middle of the burst.)

The end of a Layer 2 or 3 frame is defined to be the time of the last burst containing part of the Layer 2 or 3 frame.

2.10

MAN-MACHINE INTERFACE

The operator interacts with the system simulator by giving commands and responses and entering data to the system simulator via keyboard or other suitable input medium.

The system simulator shall display the operating status of the SS, all relevant settings, parameters, messages and results and confirm all user operations on a screen or a similar output medium.

The man-machine interface can be menu driven or command driven or a combination of these.

Messages and parameters shall have the same symbolic names and/or formats as in the GSM recommendations.

The system simulator shall provide standard test cases used for formal type approval tests defined in GSM 11.10.

It shall be possible to amend standard test cases and to create additional test cases under operator control to cater for the evolution of the test cases. It shall be possible to combine several test cases into a test group with a user definable test group name (edit mode). A test group consists at least of one test case and it shall be possible to store the test group on a transportable mass memory allowing test groups to be distributed among users of several system simulators (at least of the same make). A test case

consists of test steps further divided into test events. A test event is e.g. sending or receiving a message with associated parameters or a single measurement.

Test events and the information to be logged shall be controlled by the operator via a Test Description Language (TDL). Test cases then consist of sequences of test events; i.e. sequences of TDL statements. All signalling of the system simulator and every response from the MS on Layer 1, 2 and 3 with the corresponding real time clock readings may be logged temporarily until the next test case is initiated. All information required to generate test reports are stored in non-volatile memory.

2.10.1 Operative command functions of the system simulator

2.10.1.1 General system control commands

The general system control commands shall call system simulator service routines, access global settings and allow I/O-control functions.

At least the following functions shall be controllable:

- Hardware control functions
- Selfcheck
- Test suite maintenance
- Reset and interrupt functions
- Assignment of global parameters
- Mode control
- Define and request test report
- Output control.

Exact functions are left to the manufacturer of the SS.

2.10.1.2 Direct mode commands

The direct mode commands shall execute the tests of Layer 3 functions described in GSM 11.10, using standard test cases.

The system simulator shall carry out all preparing signalling steps automatically or with the necessary operator instructions to bring the MS into the initial state for the chosen test.

At least the following functions shall be controllable:

- assignment of test parameters,
- execute standard test.

It shall be possible to interrupt a running test in three ways:

1. Abort the test: The test is stopped immediately.
2. Stop the test: The test is stopped as quickly as possible but storing all relevant data, to be displayed if so requested by the operator.
3. Pause the test: The test is halted as quickly as possible and it shall be possible to resume the test (if the MS is left in such a state).

2.10.1.3 Edit mode command

Edit mode commands shall be implemented for test case and test group management. At least the following functions shall be controllable:

- Create/edit test cases
- Concatenate test cases to (named) test group
- Create/edit test group
- Save test group in mass memory
- Load test group to be run/edited
- Delete test group from memory
- Execute test group.

2.10.2 Functions within test cases

The commands within the test cases and the Test Description Language are not specified and the actual implementation and optimisation are left to the manufacturer of the system simulator.

At least the following functions shall be supported by the Test Description Language used to define executable test cases in the system simulator:

1. Initiate events, e.g. to send messages on Layers 2 or 3 or defined bursts or frames on Layer 1, activate and deactivate hardware. It shall be possible to initiate simultaneous events.
2. Accept events, e.g. response to a message or hardware indication according to defined response requirements, see 3 and 4. It shall be possible to require multiple or alternative responses.
3. Define response requirements and acceptance limits for signalling and measurement results, i.e. message content (whole message or parts of it), minimum and, or maximum response time and, or measurement result limits.
4. Define not-desired responses, same parameters as in 3.
5. Assign values to variables, e.g. parameters.
6. Define/start/cancel/suspend/resume timers.
7. Timer initiated events.
8. Depending on the result of a test event it shall be possible to branch to other test events or cases.
9. Put the MS into a specific Layer 3 state, using one single statement.
10. It shall be possible to request operator actions.
11. It shall be possible to include user comments.
12. The operator shall be able to create test events employing user supplied test equipment over a standard interface, see section 3.8. The TDL shall support this by providing access to the standard interface in order to control e.g. the vibration table or the climatic test chamber.

A test case is described in mnemonic Layer 3 or 2 terms and the system simulator shall automatically create lower layers.

It shall be possible to introduce errors in a lower layer by additional TDL statements. All parameter fields and formats shall correspond to those defined in the relevant GSM recommendations.

The test description language shall contain a command/statement to allow a displacement in time of the moment of the transmission of an individual message.

2.10.3 Determining the outcome of a test

GSM 11.10 specifies acceptable outcomes of a test. These shall be included in the standard test case descriptions to be provided by the manufacturer of the SS. Automatic checking of the test results shall take place during or after the test execution. The automatic checking shall cover all requirements in GSM 11.10.

It shall be possible for the operator to do his own check list for the user defined tests.

For each test case the SS shall produce a verdict stating whether the result is within or outside the design limits, see GSM 11.10 Appendix C. The test is continued wherever possible in case of a result outside the design limits.

2.10.4 Output information and format

During the test, the test status shall be indicated by displaying the SS and MS messages according to the layer under test, including the outcome of the single tests, see section 2.10.3 above.

2.10.4.1 Test report

The Test Report is defined in GSM 11.10 Appendix C.

The SS shall provide, as a minimum, all information required for the "Test Case Section" of this Test Report (GSM 11.10 Appendix C, section 3.). It shall be possible to direct the output to the display and/or a printer and store it in a mass memory. Measurement results in graphical form together with requirement masks shall be provided whenever required.

It shall be possible to print out a report on paper after each and every test.

Manual intervention and/or manual operation during the test including prompts given to the operator and operator reaction shall be logged by the SS.

2.10.4.2 Indication levels

For analysis purposes it shall be possible to present the outcome of a test with different indication levels during the test. It shall be possible to request a new presentation of the outcome of a test with changed indication level(s).

The information from possible higher indication levels shall be shown to ease the understanding of the test result.

It shall be possible to select one or more of the following indication levels:

- Indication of SS and MS Layer 3 messages using symbolic names with display of MS Layer 3 parameters. The test case description is shown in terms of Layer 3.
- Indication of SS and MS Layer 2 messages using symbolic names with display of MS Layer 2 messages and parameters with real time clock readings corresponding to actions and responses and the time difference between events. The displayed values shall be presented in number of bits or in microseconds. The test case description is shown in terms of Layer 2.
- Indication of Layer 1 activities with real time clock readings of the corresponding times of the events, i.e. bursts, speech and signalling frames and the time difference between events. The displayed value shall be in number of bits or in microseconds. The test case description is shown in terms of Layer 1. The messages from the MS shall be presented in hexadecimal and/or binary format.

The messages transmitted by the system simulator are indicated by symbolic names and their content shall be shown in hexadecimal and binary format if requested by the operator. In any case it shall be indicated if a bit error correction was done by the SS on MS messages; the indication of Layer 1 activities must show the contents of a burst after decryption from the MS and shall highlight the corrected bits.

2.10.4.3 Display of MS indicators

The SS shall display, for operator guidance, the expected state of possible indicators in the MS including indicators for supplementary services. If the MS supports the electrical man-machine interface, the system simulator shall display the actual state of indicators in the MS on operator request.

3. DESIGN REQUIREMENTS

3.1 General

The SS shall have sufficient hardware to facilitate the radio measurements and signalling tests as required in GSM 11.10.

The SS shall emulate the MS - BSS interface signalling functions and exercise the mobile station according to the signalling tests and requirements given in GSM 11.10.

The level and sensitivity specifications in sections 3.3 and 3.4 refer to the MS antenna connector port (ref: section 3.2.1.1). For tests where the MS is not connected directly to the SS the following requirements apply:

- The upper end of the level range of SS generated signals shall be increased by an amount given by the losses due to the different coupling attenuations (section 3.2).
- The lower end of the level range of SS measured signals shall be reduced by an amount given by the losses due to the different coupling attenuations (section 3.2).

In sections 3.3 and 3.4, figures in "()" represent the extreme values when considering measurements using the antenna coupling device (3.2.1.4) or interfering field/substitution antennas (3.2.1.2/3.2.1.3) where appropriate.

All uncertainty values quoted in this specification, are quoted for a Confidence Level of 95%.

3.2 MS TEST PORT SPECIFICATION

3.2.1 RF test ports

The SS shall be capable of interfacing with the following:

- 1) Mobile Station antenna connector
- 2) Substitution antenna
- 3) Interfering-field antennas
- 4) Antenna coupling device.

3.2.1.1 Mobile station antenna connection

The requirements for measurement capabilities and test signals are defined at the MS antenna connector.

VSWR	GSM bands	< 4 GHz	< 10 GHz	< 12.75 GHz
with 10 dB attenuator	≤ 1.2	≤ 1.5	≤ 2.5	≤ 3.0
without attenuator	≤ 1.3	≤ 2.0	≤ 3.0	≤ 3.5

During the tests II.2.2 of GSM 11.10, the VSWR of the above table shall not exceed 2.2 over the whole frequency range, up to 12.75 GHz.

Input impedance : 50 ohm
Power handling capability: 50 Watt RMS

3.2.1.2 Substitution antennas

This part is required for testing a MS with integrated antenna or cabinet radiation tests.

3.2.1.3 Interfering field antenna

This port is required for testing a MS with an integral antenna on a test site or within an anechoic chamber as defined in GSM 11.10, Annex 1, GC4, GC5.

The coupling loss shall not exceed:

- 57 dB over a frequency range of 30 MHz to 87 MHz
- 42 dB over a frequency range of 87 MHz to 900 MHz
- 32 dB over a frequency range of 900 MHz to 4 GHz.

Notes:

- 1) This coupling loss includes assumed coaxial cable loss.
- 2) This coupling loss is based on a distance between the MS under test and the interfering field antenna of:
 - 3 meter for frequencies in the range 30 MHz to 900 MHz
 - 1 meter for frequencies in the range 900 MHz to 4 GHz.

The RF output and input levels of the SS at these ports shall be adjusted, taking these losses into account.

3.2.1.4 Antenna coupling device

This port is required for testing a MS with an integral antenna. An antenna coupling device is described in GSM 11.10 Annex 1, General Conditions GC6.

The RF output and input levels of the SS at this port shall be modified to cope with the 30 dB coupling loss.

3.2.2 MS audio test ports

3.2.2.1 LRGP, artificial mouth and artificial ear

The handset of the MS is mounted in the LRGP (loudness rating guard ring position), see Rec. CCITT P.76, Annex A.

The artificial mouth shall conform to Rec. CCITT P.51 and the artificial ear shall conform to Recs. CCITT P.51 and IEC 318.

The artificial mouth and ear shall be acoustically isolated from each other so that the through connection of the speech path in the MS can be verified in both directions simultaneously. The isolation shall be sufficient to allow sidetone measurements.

3.2.2.2 Digital Audio Interface (DAI)

See GSM 11.10/III.1.4.

3.2.3 User data interfaces in the MS

The SS shall be capable to test user data interfaces, see section 2.5.

3.2.4 MS power supply interface

Test DC power supply for MS:

Voltage range	5 to 32 V
Voltage error	< 1 %
Current	> 15 A
Ripple	< 10 mV RMS, 50 mV peak to peak

Test AC power supply for MS:

Voltage control range	198 - 264 Volt
Voltage error	< 1 %.

In some tests the MS shall be connected to the power supply via a radio frequency filter to avoid radiation from the power leads.

See also GSM 11.10 Annex 1, Test Conditions.

3.2.5 Electrical MS man-machine interface (EMMI)

The system simulator shall operate the electrical MS man-machine interface, EMMI, as specified in GSM 11.10/III.1.3.

The Test Description Language shall include all necessary functions for the EMMI.

3.3 RF Measurement capabilities

3.3.1 RF power measurements

3.3.1.1 Power versus Time measurements

See GSM 11.10 section II.3.3 for definitions and method of measurement.

Frequency range: 890 - 915 MHz

Peak transmitter carrier power range +46 dBm to +9 dBm (-23 dBm)

Measurement uncertainty of peak transmitter carrier power: +/- 1 dB

Measurement range for the individual power samples in any 1 burst:
80 dB within 50 dBm to -36 dBm (-68 dBm)

Measurement uncertainty of power level (relative to peak transmitter carrier power):

Power level	Measurement uncertainty
+ 6 dB to - 7 dB	+/-0.25 dB
- 7 dB to -20 dB	+/-1.0 dB
-20 dB to -32 dB	+/-2.0 dB
-32 dB to -45 dB	+/-5.0 dB
-45 dB to -71 dB	+/-1.0 dB
<-71 dB	+/-2.0 dB

Note: Due to the method of measurement (downconversion to I/Q baseband / filtering / A/D conversion / postprocessing) several uncertainties occur. The sources are:

- a) absolute level uncertainty;
- b) filter ripple,
I/Q gain imbalance,
I/Q imperfect quadrature;
- c) A/D conversion (resolution),
I/Q offset.

Items under b) and c) affect the individual samples and can be observed as a "ripple" in the horizontal part of the power time mask.

Items under b) are uncertainties which are proportional to the signal measured.

Items under c) are constant amounts of uncertainty, independent of the signal measured.

The item a) moves the entire power time template up or down.

The uncertainties b) and c) are added to the measured signal as an uncorrelated interferer.

The above mentioned absolute measurement uncertainty refers to a). The table covers uncertainties b) and c).

Uncertainty of time measurement

The relative timing uncertainty of the transition point

- bit 13 to 14 in the midamble (normal burst)
- end of the sync sequence (access burst)

is +/- 1/8 bit.

Note: For type testing to the current standard, the timing uncertainty is to be considered as if extended in front of the raising and the falling edge each by 1/2 bit (1.84 μ s). The asymmetry of the resulting "timing uncertainty" allows two possible implementations of the burst timing reference (see GSM 11.10, II.3.3.1).

Timing uncertainty of the measurement samples and its "extension" in the vertical part of the power time mask are displayed as marked fields in the Figure App.3-1 in Appendix 3.

Note: With a real method of measurement one has to reckon on systematic measurement uncertainties in the vertical part of the power time template (Figures II.3.3 and II.3.4 /GSM 11.10). The reason for this is that the measurement is conducted through a filter which has to fulfil different requirements simultaneously, requirements in the frequency domain and in the time domain as well. The time behaviour of the filter causes the above mentioned measurement uncertainty. It occurs clearly when measuring the falling edge of the power burst. The measurement uncertainty, which in principle delays the actual performance, depends on the filter characteristics and on the signal shape. At favourable signal shapes the uncertainty is negligible, however, at unfavourable signal shapes it consumes the marked area in Figure App.3-1 (falling edge).

The underlying filter is:

type	inverse Chebycheff
passband	<= +/- 200 kHz
stopband (40 dB stop att.)	>= +/- 541.67 kHz.

To avoid aliasing with this filter the RF output spectrum must meet the requirements of GSM 11.10 section II.3.4.

If the -70 dB line in the power time template is replaced by a -36 dBm line, measuring lower carrier powers, the area of measurement uncertainty is reduced equivalently.

The matching criteria (GSM 11.10 section II.3.3 c) and g)) are Figures II.3.3 and II.3.4 / GSM 11.10. The marked area in Figure App.3-1 describes the systematic measurement uncertainty of the test equipment and does not widen the design requirements.

Uncertainties associated with Requirement b) of GSM 11.10 section II.3.3.3 (power control levels, adjacent steps):

Repeatability	+/- 0.3 dB
Linearity	+/- 0.03 dB/dB

Combined uncertainty is: +/- (0.3 + 0.03 dB/dB) dB

E.g. where the indicated value of the step size is 2.0 dB, the uncertainty is: +/- (0.3 + 0.06) dB = +/- 0.36 dB.

3.3.1.2 Wideband selective power measurement

Power is to be measured selectively for spurious emissions without frequency hopping (ref: GSM 11.10/II.2.2).

Frequency range	100 kHz to 12.75 GHz (30 MHz to 4 GHz)
Range	(-114)-60 to +47 dBm
Dynamic range	80 dB
Uncertainty	< +/- 1.5 dB (+/- 6.0 dB)

Resolution bandwidths:	10, 30, 100 and 300 kHz 1 and 3 MHz
Video bandwidths:	30, 100 and 300 kHz, 1 and 3 MHz
Peak hold function	activated

It is acceptable to use a band stop filter in spurious emission measurements of the transceiver in order to fulfil the above requirements.

3.3.1.3 Inband selective power measurements

Power is to be measured selectively for output RF spectrum

The measurement is performed on a single frequency while the MS is frequency hopping (ref: GSM 11.10/II.3.4)

Frequency range:	888 MHz to 917 MHz
level range:	(-66) -36 dBm to +47 dBm
Frequency range:	935 MHz to 960 MHz.
level range:	(-109) -79 dBm to +47 dBm
Uncertainty	< +/- 1.6 dB
Resolution bandwidth	30, 100 kHz
Video bandwidth	30, 100, 300 kHz
Video averaging:	50, 200 timeslots
Zero frequency span	
Peak hold function	activated

The video signal of the spectrum analyser is "gated" such that the spectrum generated by at least 40 of the bits 87 to 132 of the burst is the only spectrum measured. This gating may be analogue or numerical, dependent upon the design of the spectrum analyser.

3.3.2 Phase trajectory and frequency error measurements

See GSM 11.10/II.3.1 for definitions and methods of measurement.

Frequency range:	890 - 915 MHz
Level range (peak transmitter carrier power)	46 dBm to 9 dBm (-23 dBm)
Phase measurement uncertainty	< 1 degrees RMS < +/- 4 degrees for individual phase measurement samples

The phase measurement uncertainties above apply during the useful bits.

Frequency measurement uncertainty: +/- 5 Hz.

3.3.3 RF delay measurements relative to nominal times

Range	-140 to +140 bit periods
Resolution	1/4 bit period
Uncertainty	< +/- 1/8 bit period

See also section 2.8.

3.4 RF test signals

The specifications of the RF-test signals are defined at the SS test port connection.

The output levels are defined to allow a loss between the test port and the MS connector as described in 3.2.1

The SS shall provide calibration facilities to calibrate the level at the MS end of the cable.

See section 3.4.7 for the numbering of tests in this section.

3.4.1 The Wanted signal or Traffic channel of serving cell

The Wanted signal is used in most of the specified RF measurements. The traffic channel of the serving cell is used in most of the signalling tests.

FREQUENCY:

Range 935 to 960 MHz
 Resolution..... 200 kHz
 Fine tuning +/- 300 Hz in 2 Hz steps
 Error < 5*10E-9

PHASE:

Error < 1 degree RMS and
 < +/- 4 degrees peak (as defined in GSM 05.054)

LEVEL:

Range 0 dBµV to 106 dBµV EMF
 (+30 dB for test fixture)
 Step size 0.2 dB
 Error < +/- 1 dB in test 3,11,13
 < +/- 1 dB for test 7 (conducted)
 < +/- 3 dB for test 7 (radiated)
 < +/- 1.2 dB for test 10
 < +/- 2.5 dB for all other tests.
 Settling time < 10 µs

MODULATION GMSK (as specified in GSM 05.04)

SPURIOUS:

Inchannel spurious
 residual FM, phase mod: covered by phase error
 Outchannel spurious
 Noise Power.... <-100 dBc for > 100kHz carrier offset, 1Hz bandwidth
 <-110 dBc for > 300kHz carrier offset, 1Hz bandwidth
 <-121 dBc for >1500kHz carrier offset, 1Hz bandwidth
 non harmonics.. < -55 dBc for > 100kHz carrier offset
 < -68 dBc for >1500kHz carrier offset

FADING PROFILES..... corresponding to section 3.4.6

FREQUENCY HOPPING:

The signal shall be capable of hopping according to the criteria of GSM 05.02. The timing of the frequency change shall be such that frequency transitions do not occur during the active timeslot of the MS.

3.4.2 The First interfering signal or Traffic channel of the first adjacent cell

The First interfering signal is used in measurements of co-channel rejection, adjacent channel rejection and intermodulation rejection. The Traffic channel of the first adjacent cell is used in handover tests.

FREQUENCY:

Range 933 to 962 MHz
 Resolution..... 200 kHz
 Error < 5*10E-9
 Fine tuning +/- 300 Hz in steps of 2 Hz

PHASE:

Error < 1 degree RMS and
 < +/- 4 degrees peak (as defined in GSM 05.05)

LEVEL:

Range 0 dBµV to 73 dBµV EMF
 (+30 dB for test fixture)
 Step size 0.2 dB
 Error < +/- 1 dB relative to the wanted signal for
 test 3 and 9
 < +/- 0.3 dB relative to the wanted signal
 for test 8
 < +/- 1 dB for test 10
 < +/- 2.5 dB for all other tests

MODULATION

GMSK (as specified in GSM 05.04)

The total relative single sideband power (noise + harmonics) in the frequency range 1.5 to 1.7 MHz offset from the nominal carrier frequency shall be less than -72 dBc.

SPURIOUS:

Inchannel spurious
 residual FM, phase mod: covered by phase error
 Outchannel spurious
 Noise Power, 1 Hz bandwidth:
 <-100 dBc for > 100kHz carrier offset
 <-110 dBc for > 300kHz carrier offset
 <-127 dBc for >1500kHz carrier offset
 non harmonics < -55 dBc for > 100kHz carrier offset
 < -68 dBc for >1500kHz carrier offset

FADING PROFILES..... corresponding to section 3.4.6

FREQUENCY HOPPING:

The signal shall be capable of hopping according to the criteria of GSM 05.02. The timing of the frequency change shall be such that frequency transitions do not occur during the active timeslot of the MS.

3.4.3 The Second interfering signal

The second interfering signal is used in the measurements of intermodulation rejection and blocking.

FREQUENCY:

Range 915 to 980 MHz
 Resolution 100 kHz
 Error 5*10E-9

LEVEL:

Range 0 dB μ V to 90 dB μ V EMF
 (+30 dB for test fixture)
 Step size 0.2 dB
 Error < +/- 1 dB for test 10
 < +/- 1.5 dB relative to the wanted signal
 for all other tests.

MODULATION unmodulated

SPURIOUS:

Inchannel spurious no requirements
 Outchannel spurious
 Noise Power:
 <-135 dBc for > 500kHz carrier offset, 1Hz bandwidth
 <-140 dBc for > 700kHz carrier offset, 1Hz bandwidth
 <-150 dBc for >1500kHz carrier offset, 1Hz bandwidth
 non harmonics < -79 dBc for > 500kHz carrier offset
 < -84 dBc for > 700kHz carrier offset
 < -94 dBc for >1500kHz carrier offset
 Harmonically related spuri <-40 dBc

3.4.4

BCCH carriers of serving and adjacent cells

The BCCH of the serving cell is used for synchronising the MS and to send network information to the MS under test. The BCCH signals of the adjacent cells are used in the handover tests. The MS measures the RF-levels of the BCCHs of adjacent cells.

FREQUENCY:

Range 935 to 960 MHz
 Resolution..... 200 kHz
 Error < 5*10E-9

PHASE:

Error < 1 degree RMS and
 < +/- 4 degrees peak (as defined in GSM 05.05)

LEVEL:

Range 0 dB μ V to 70 dB μ V EMF
 (+30 dB for antenna coupling device)
 Step size 1 dB
 Error < 1 dB for test 3
 < 2.5 dB for all other tests
 < 0.6 dB relative to each other and to TCH/WS
 for test 13 over the range 65 dBmicroVolt
 to 3 dBmicroVolt
 < 1.2 dB relative to each other and to TCH/WS
 for test 15.

MODULATION GMSK (as specified in GSM 05.04)

SPURIOUS:

Inchannel spurious
 residual FM, phase mod: covered by phase error
 Outchannel spurious
 Noise Power..... <-100 dBc for > 100kHz carrier offset, 1Hz bandwidth
 <-125 dBc for >1500kHz carrier offset, 1Hz bandwidth
 non harmonics..... < -55 dBc for > 100kHz carrier offset
 < -72 dBc for >1500kHz carrier offset

TIME BASE

Error..... < $5 \cdot 10^{-9}$ within calibration cycle

FADING PROFILES (Serving and first adjacent cells only)

..... corresponding to section 3.4.6

3.4.5 The wide frequency range signal

The wide frequency range signal is used in the measurements of spurious response. The second interfering signal can be used for frequencies 915 MHz to 980 MHz.

FREQUENCY

Range 100 kHz to 12.75 GHz, excluding 915 MHz to 980 MHz

Resolution 100 kHz

Error < $5 \cdot 10^{-9}$

LEVEL

Range 0 to 113 dBmicroVolt EMF

Output signal versus frequency for blocking test, for test without an antenna connector:

80 - 200 MHz	:	119 dB μ V(emf)
200 - 500 MHz	:	119 dB μ V(emf)
500 - 835 MHz	:	129 dB μ V(emf)
835 - 915 MHz	:	153 dB μ V(emf)
980 - 1000 MHz	:	143 dB μ V(emf)
1000 - 2500 MHz	:	113 dB μ V(emf)
2500 - 4000 MHz	:	113 dB μ V(emf)

Step size.... 0.2 dB

Error < +/- 1.5 dB relative to the wanted signal for test 11
< +/- 1 dB error of substituted 'wanted signal'

MODULATION unmodulated

TIMING no timing requirements

SPURIOUS in the frequency range 935 MHz to 960 MHz

Non harmonics < -94 dBc

Harmonically related spuri < -40 dBc

Noise < -4 dB μ Vemf equivalent at the MS receiver input when measured in a 200 kHz bandwidth.

3.4.6 The multipath fading function

The multipath fading function simulates the fading effects of a broadband radio channel in mobile radio communication. These effects are due to the multiple propagation paths between transmitter and receiver with different delays, Doppler-spectra and level-variations of each path.

The propagation conditions are specified in GSM 05.05, annex 3.

The multipath fading function shall support the fading profiles of the following propagation models:

Models	Simulated vehicle speeds:				
	3	50	100	250 km/h	
RA	.	.	.	W	W=Wanted signal I=First interferer
HT (6taps)	.	.	W	.	
TU (6taps)	W,I	W,I	.	W	
EQ		W			

FREQUENCY:

Bandwidth 935 to 960 MHz (Wanted signal)
 932 to 962 MHz (First interfering signal)

The multipath fading function shall be performed only within a 5 MHz bandwidth during one test case.

3.4.7 Combinations of test signals

The following combinations of test signals are used. The individual specification of signals shall apply when the signals are combined as below.

No	Transceiver tests	Serv.cell		first adj. cell		6 adj cells		I2	WF	
		TCH WS	BCCH CO	TCH I1	BCCH CO	BCCH CO				
1	Spurious emissions	x	x							6)
	Transmitter tests									
2	Phase/frequ. error	xh	x		x					6)
3	Phase/frequ. error multip	xf	xf	xf	xf	x				6)
4	Peak TX carrier power	x	x							
5	Output RF spectrum	xh	x							6)
	Receiver tests									
6	Bad frame indication	x	x							
7	Sensitivity tests	xhf	xf			x				1)
8	Co-channel rejection	xhf	xf	xhf						3)4)
9	Adjacent channel rej.	xf	xf	xf						3)
10	Intermodulation rejection	x	x	x			x			2)3)
11	Blocking, spurious resp.	x	x		x		x	x		5)
12	Signalling tests	xh	x	xh	x					
13	RXLEV & Cell select/resel	x	x		x					
14	RXQUAL tests	x	x	x						3)
15	Measurement report	x	x			x				

WS: wanted signal WF: wide frequency range signal
 I1: first interferer I2: second interferer

x = simultaneously used signals, h = frequency hopping, f = fading

Notes: The notes which are referenced in the table above have a meaning which applies in the case of that specific test only. They must not be taken as statements with general validity:

- 1) Hopping and fading are not used simultaneously.
- 2) The level of the intermodulation product at the MS receiver shall not exceed -4 dB μ V emf.
- 3) There shall be no correlation in the modulation between the test signals nor shall there be a fixed relationship in the phase of the signals. (GSM 11.10/II.4.7.2.a)/f.2))
- 4) The tests in GSM 11.10 are arranged that the multipath fading function shall be performed within a 5 MHz bandwidth during one test case.
- 5) I2 and WF not used simultaneously.
- 6) Standard Test Signal C1 used.

3.5 Audio test signals

GSM 11.10 specifies the following audio test signals to be used in the transmission measurements.

3.5.1 Analog single test tone

The analog single test tone shall be applied to the Mouth Reference Point (MRP) by the Artificial Mouth, see Annex A of CCITT P.76.

Frequency range:	100 Hz to 8000 Hz.
Frequency error:	0.1 %
Sound pressure at the MRP over the full frequency range:	-4.7 dBPa
Sound pressure at the MRP in the frequency range 1004-1025 Hz:	-46 to +10 dBPa
Error	+/- 0.2 dB
Total distortion:	< 0.5 %

3.5.2 Digital 8 bit PCM test signals

The digital test signals below shall be generated as 8 bit A-law companded PCM signals, which internally in the System Simulator are expanded according to CCITT Rec G.721 (Law=1) to 13 bit linear before being applied to the MS via the DAI.

3.5.2.1 Digital 8 bit PCM single test tone

Frequency range:	100 to 4000 Hz
Frequency error:	< 0.1 %
Range :	-45 to 0 dBm0

3.5.2.2 Decoder output value 1

See test GSM 11.10/ II.11.1.5) and CCITT G.711.

3.5.2.3 Digital 8 bit PCM band limited noise test signal

The digitally simulated band limited noise test signal shall correspond to CCITT O.131.

Output level: -10 dBm0

3.6 AUDIO MEASUREMENT CAPABILITIES

3.6.1 General

Unless otherwise specified, the measurement uncertainty for signal level is $< +/- 0.2$ dB and for sound pressure $< +/- 0.6$ dB.

Frequency settings are taken from ISO 3, R10 series or R40 series or from Table 2 of Rec. CCITT P.79. A departure from the nominal frequencies of $+/- 5%$ below 240 Hz and $+/- 2%$ at 240 Hz and above is accepted.

In the case of 4 kHz the departure is restricted to $-2%$.

The SS shall calculate the MS response according to test descriptions in GSM 11.10/II.11.1 and present the results graphically together with the specified mask and indicate if requirements are fulfilled at least for the measurements:

- Sending sensitivity/frequency response (GSM 11.10/ II.11.1.1).
- Receiving sensitivity/frequency response (GSM 11.10/ II.11.1.3)
- Distortion, sending and receiving (GSM 11.10/ II.11.1.8)
- Out of band signals (GSM 11.10/ II.11.1.9).

3.6.2 Sound level/pressure measured at the Ear Reference Point

The mobile station handset shall be mounted in the LRGP as specified in Annex A of Rec. CCITT P.76. The earpiece shall be sealed to the knife-edge of the Artificial Ear. The SS shall measure the level of the sound with the following characteristics:

Frequency range : 100 to 8000 Hz (GSM 11.10/ II.11.1.10.2)
 Dynamic range : -70 dBPa to 35 dBPa
 Uncertainty : $< +/- 0.6$ dB

Measurements shall be possible with and without psophometric weighting according to Rec. CCITT G.223, Table 4.
 Sound level measurement equipment shall conform to Rec. IEC 651, type 1.

3.6.2.1 One-third octave measurements

The SS shall measure sound pressure in one-third octave bands.
 Frequency range : 100 Hz to 3000 Hz (Bands 1-20)
 Total measurement range: -80 to +30 dBPa.

3.6.2.2 A-weighted measurements

A-weighted sound pressure measurements shall be possible
Measurement range: -44 to -24 dBPa(A).

3.6.3 Distortion

Distortion shall be measured according to Rec. CCITT 0.132, sine wave method (GSM 11.10/II.11.1.8).

Dynamic range: -46 and above to +10 dBPa, relative to ARL, at the
MRP (sending direction).
-45 to 0 dBm0 (receiving direction).

Measurement range for signal to distortion ratio: 10 to 40 dB.

3.6.4 DAI level measurements

When measuring signal levels on the DAI, a digital measuring instrument is connected to the 64 kbit/s output of the A-law compression equipment (see also 3.5.2) in the SS, which is in turn connected to the DAI in the MS. The digital measuring instrument shall fulfill the following requirements:

Frequency range	:	100 Hz to 4000 Hz
Power level	:	-60 dBm0 to 3.14 dBm0
Idle channel noise:		-70 dBmOp to -50 dBmOp

Measurements shall be possible with and without psophometric weighting according to Rec. CCITT G.223, Table 4.

3.6.5 Delay measurements

3.6.5.1 Delay measurement between Um and DAI

The SS shall be able to determine the delay between the Um interface of the MS and its DAI in both directions, as described in GSM 11.10/II.13.5.

The SS supplier shall indicate and guarantee the delays within the system simulator from speech test sequence generator output to the Um interface and from the Um interface to the input of the test sequence comparator.

Range of measurable MS delay:	0 to 100 ms
Uncertainty	< +/- 0.1 ms

3.6.5.2 Delay measurement between DAI and acoustic interface

The SS shall be able to determine the delay from the DAI to the acoustic interface and vice versa by the method described in GSM 11.10/II.13.5. The SS supplier shall indicate and guarantee the delay within the measurement system.

Range of measurable MS delay:	0 to 10 ms
Uncertainty	< +/- 0.1 ms

3.6.6 AF frequency counter

This equipment is not a mandatory feature of the SS. The following characteristics are given for guidance.

Range	:	50 to 20000Hz
Uncertainty	:	< +/- 0.1%
Input level	:	-26 dBV to +20 dBV

3.7 SIM SIMULATOR

The SIM simulator shall connect to the SIM/ME interface as described in GSM 11.10/III.1.5.

Note: The Elementary Time Unit (etu) used in the sections below refer to the nominal bit duration on the I/O line, as defined in ISO 7816-3.

3.7.1 Measurements on the contacts C1, C2, C6, C7

3.7.1.1 Voltage Measurement

To verify that the minimum and maximum values of V_{IH} and V_{IL} (see GSM 11.11, section 6.2.3 and ISO 7816-3, section 4.2) are fulfilled and that there are no bursts on the signal, the System Simulator shall measure the range of V_{IH} and V_{IL} signal).

It shall be possible to recognize and record at least one burst within 100 ns. Bursts with a length of > 20 ns shall be recognized and recorded with a time stamp. relative to power on.

Range	- 1 V to 7 V
Resolution	100 mV
Uncertainty	< +/- 50 mV

Time resolution	200 ns
Uncertainty	< +/- 100 ns.

3.7.2 Measurements and Definitions on the contact C1

The SIM Simulator shall be able to verify that V_{CC} is able to source current spikes, defined in GSM 11.11, section 6.2.5.

Therefore the SIM Simulator shall be able to define:

- 1) Single Spikes Current Load

0 - 300 mA
Step Size 10 mA
Error +/- 2 mA

Pulse Width	100 - 500 ns
Step Size	50 ns
Error +/-	25 ns

Rise and Fall Time	
10 ns +/- 5ns for transition	from 0-100 mA
30 ns +/- 10ns for transition	from 100-300 mA

2) Continuous Spikes

Current Load 0 - 20 mA
 Step Size 1 mA
 Error +/- 0.5 mA

Characteristics Duration 100 - 500 ns
 Pause 100 ns - 100 s
 Step Size 50 ns
 Error +/- 25 ns

Rise and Fall Time
 Range 20 ns
 Error +/- 10 ns

3) Pseudorandom Spikes

Number of Spikes/Second 1-1000
 Characteristics as for Continuous

3.7.3 Measurements and Definitions on the contact C7

3.7.3.1 Rise and Fall Time measurement

This feature is used to verify, if the rise and fall time of the ME in transmission mode is in the range specified in ISO 7816-3, section 4.2.3. Therefore, the SIM simulator shall be able to measure the rise and fall time.

Range up to 2 μ s

Uncertainty < \pm 100 ns

3.7.3.2 Rise and Fall Time Definition

This feature is used to verify, if the ME accepts in reception mode the rise and fall time specified in ISO 7816-3, section 4.2.3. Therefore, it shall be possible to define the rise and fall time of the System Simulator.

Range 100 ns to 2 μ s

Step size 100 ns

Error < \pm 100 ns

3.7.3.3 Voltage Definition

The SIM Simulator shall be able to verify that the ME accepts minimum and maximum values of V_{OH} and V_{OL} specified in ISO 7816-3, section 4.2.3. Therefore, it shall be possible to define the V_{OH} and V_{OL} of the System Simulator.

Range see GSM 11.11, section 6

Step size 20 mV

Error < +/- 20mV

3.7.3.4 Jitter Measurement

This feature is used to verify, if the jitter of the ME is in the range specified in GSM 11.11, section 5.4.

Range > +/- 0,3 etu

Uncertainty < +/- 5*10E-3 etu

3.7.3.5 Jitter Definition

The SIM Simulator shall be able to verify that the ME accepts the jitter specified in GSM 11.11, section 5.4. Therefore, it shall be possible to define the jitter of the System Simulator.

Range > +/- 0,3 etu

Step size 5*10E-3 etu

Error < +/- 5*10E-3 etu

3.7.3.6 Error Signal Measurement

It shall be possible to predefine parity errors in the SIM Simulator and to measure the error signal of the ME.

Range see ISO 7816-3, section 6.1.3

Uncertainty < ± 5*10E-3 etu

3.7.3.7 Error Signal Definition

The SIM Simulator shall be able to verify that the ME accepts an error signal of the SIM in the range specified in ISO 7816-3, section 6.1.3. Therefore, it shall be possible to send an error signal and to define the timing of the error signal.

Range see ISO 7816-3, section 6.1.3

Step size 5*10E-3 etu

Error < +/- 5*10E-3 etu

3.7.4 Measurements on the contact C3

3.7.4.1 Frequency Measurement

Range 0,9 MHz to 5,5 MHz

Uncertainty < ± 0,5 %

3.7.4.2 Voltage Measurement

To verify that the minimum and maximum values of V_{IH} and V_{IL} (see GSM 11.11, section 6.2.3 and ISO 7816-3, section 4.2.5) are fulfilled, and that there are no bursts on the clock signal, the System Simulator shall measure the range of the V_{IH} and V_{IL} signal.

It shall be possible to recognize and record at least one burst within 100 ns. Bursts with a length of > 20 ns shall be recognized and recorded with a time stamp relative to power on.

Range - 1 V to 7 V

Uncertainty $< \pm 50$ mV

3.7.4.3 Rise and Fall Time Measurement

This feature is used to verify, if the rise and fall time of the ME is in the range specified in ISO 7816-3, section 4.2.5. Therefore, the SIM Simulator shall be able to measure the rise and fall time.

Range up to 200 ns

Uncertainty $< \pm 5$ ns

3.7.4.4 Duty Cycle Measurement

This feature is used to verify, if the duty cycle is in the range specified in GSM 11.11, section 6.2.1. Therefore, the SIM Simulator shall be able to measure the duty cycle.

Range 35 % to 65 %

Uncertainty $< \pm 2,5$ %

3.7.5 Power Sources

The SIM Simulator shall be able to drive lines with the specified maximum source and sink currents (see GSM 11.11, section 6.2.5 and ISO 7816-3, section 4.2).

3.7.6 Verification of the Activation- and Deactivation Sequence

This feature is used to verify, if the sequence of activation and deactivation of the SIM contacts is in accordance with ISO 7816-3, section 5 and GSM 11.11, section 6.1.2. The timing of this sequence is not defined, and therefore the SS shall be able to detect as small a time interval, between events in the sequence, with a resolution of at least 100 ns. If the sequence is so fast during testing of a specific ME, as to exceed the resolution of the sequence detector, then an oscilloscope should be employed.

Note: This test will only be performed when a ME is soft-powered down. If during MS operation the SIM is physically removed, it is impractical to ensure correct sequencing of deactivation and the possible damage to the SIM cannot be safeguarded by a type approval test. Furthermore, in this situation the integrity of SIM data is not guaranteed (see GSM 02.17).

3.7.7 Beginning of the Answer to Reset

It shall be possible to define the beginning of the answer to reset for all types of reset.

The possible range for the beginning shall be from 1 to 100.000 clock cycles in steps of 1 clock cycle.

3.7.8 Definition of Timing

It shall be possible to define all timings relative to the clock. The SIM Simulator shall be able to calculate and to use the absolute values automatically, even if the ME changes the frequency during the communication.

3.7.9 Work waiting time

It shall be possible to predefine the time between the start leading edge of any character sent by the card and the start leading edge of the previous character (sent either by the card or by the interface device). This feature is used to test the evaluation of the ATR-character TC2 and to define different calculation times for the instructions (e.g. RUN-GSM-ALGORITHM).

3.8 THE SYSTEM SIMULATOR CONTROL SYSTEM

The control system must have sufficient capacity for all tests. The control unit shall control all other subunits of the system simulator over a standard interface. It shall be possible to connect additional standard test equipment such as vibration table, climatic test chamber etc. to this interface.

It shall be possible to print out test results on paper without disturbing the test execution.

It shall be possible to print graphic presentations of measurement results together with requirement masks.

The SS shall have read/write capabilities on IBM*) PC/AT MS/DOS*) diskettes of 1.44 Mb or RAM and ROM for comparison purposes of at least 1.44 Mb. Such diskettes will also be used for distribution of test descriptions and test results between test houses.

*) trademark of International Business Machines Corporation

***) trademark of Microsoft Corporation

3.9 ENVIRONMENTAL REQUIREMENTS

The system simulator is intended for use in normal room conditions.
Temperature range : 15 to 35 degree centigrade
Humidity : 20% to 75% relative.

3.10 CALIBRATION OF THE SYSTEM SIMULATOR

The system simulator shall at predefined intervals, on request or before certain measurements perform a self calibration routine. The outcome of this calibration shall be indicated in the measurement reports or separately on request.

The system simulator shall periodically be calibrated at a designated laboratory. The calibration method and the time required to perform the calibration shall be specified by the supplier of the system simulator.

3.11 TRANSMITTER AND RECEIVER CONSTRUCTION IN THE SS

The receivers and transmitters in the SS shall fulfill the requirements of the base station receiver under non-extreme conditions, see GSM 11.20, unless otherwise stated above.

4. VERIFYING THE SYSTEM SIMULATOR

The manufacturer of the SS shall publish details of how it is verified that all given requirements are fulfilled and shall also deliver an individual verification report with the SS. The functions of the system simulator and the test cases specified in GSM 11.10, as described by the manufacturer using the Test Description Language, must be verified.

Appendix 1: EXAMPLES OF SIGNALLING PROCEDURES

MS terminated call
Handover
Call clearing

T: SS Transmit R: SS Receive

	Cell 1 BCCH CCCH PCH RACH AGCH SDCCH TCH FACCH SACCH	Cell 2 SDCCH TCH FACCH SACCH	Adjacent cells 7 BCCH
Idle	T / T(paging group)		T
Paging req	T		T
Chan. reques	T R		T
Imm. ass.	T T (T)*		T
Paging resp.	T (T)* TR		T
Authent.	T . TR		T
Ciphering	T . TR		T
Call init.	T . TR		T
Assignment	T . T TR		T
Alert	T . (T)* TR		T
Call accept	T . . TR		T
Conversation	T . . TR		T
Handover cmd	T . . TR		T
Handover acc	T . . (T)1)	TR	T
Physical inf	T . . (T)1)	TR	T
Handov compl	T . . .	TR	T
Conversation	T . . .	TR	T
Clearing	T . . .	TR	T
Channel rel	T (T)*	TR	T
Idle	T / T(paging group)	(T)*	T
	1 transmitter	+ 1 TX	+ 7TX

* : To be clarified if simultaneous transmission is necessary. The moment when the MS goes to another channel is not specified burst exactly. The MS can also go back to the SDCCH any time after "lower layer failure".

1) : The SS must keep the "old" TCH active when testing unsuccessful handover. The MS can reactivate the old TCH any time after a "lower layer failure" or after timer T3124 runs out.

APPENDIX 1
page 2 (2)

MS originated call, half rate, Lm
Additional assignment
Call clearing

T: SS Transmit R: SS Receive

BCCH CCCH	Cell 1						Half rates		Adjacent cells 7 BCCH	
	PCH	RACH	TCH AGCH SACCH	TCH SDCCH SACCH	Lm1 FACCH	Lm2 FACCH				
Idle	T	/ T(paging group)								T
Chan. reques	T	T							T	
Imm. ass.	T		T	(T)*					T	
Service ind	T		(T)*	TR					T	
Authentic.	T			TR					T	
Ciphering	T			TR					T	
Call init.	T			TR					T	
Assignment	T			T	TR	T?			T	
Alert	T			(T)*	TR	T?			T	
Call accept	T				TR	T?			T	
Lm1 in use	T				TR	T?			T	
Addit. ass.	T				TR	TR			T	
Assignm.cmpl	T				TR	TR			T	
Lm1&Lm2 used	T				TR	TR			T	
Partial rel	T				TR	TR			T	
P. rel. cmpl	T				T?	TR			T	
Lm2 in use	T				T?	TR			T	
Clearing	T				T?	TR			T	
Channel rel	T		(T)*		T?	TR			T	
Idle	T	/ T(paging group)								T

* : See note on the previous page.

Appendix 2: TEST CONFIGURATIONS

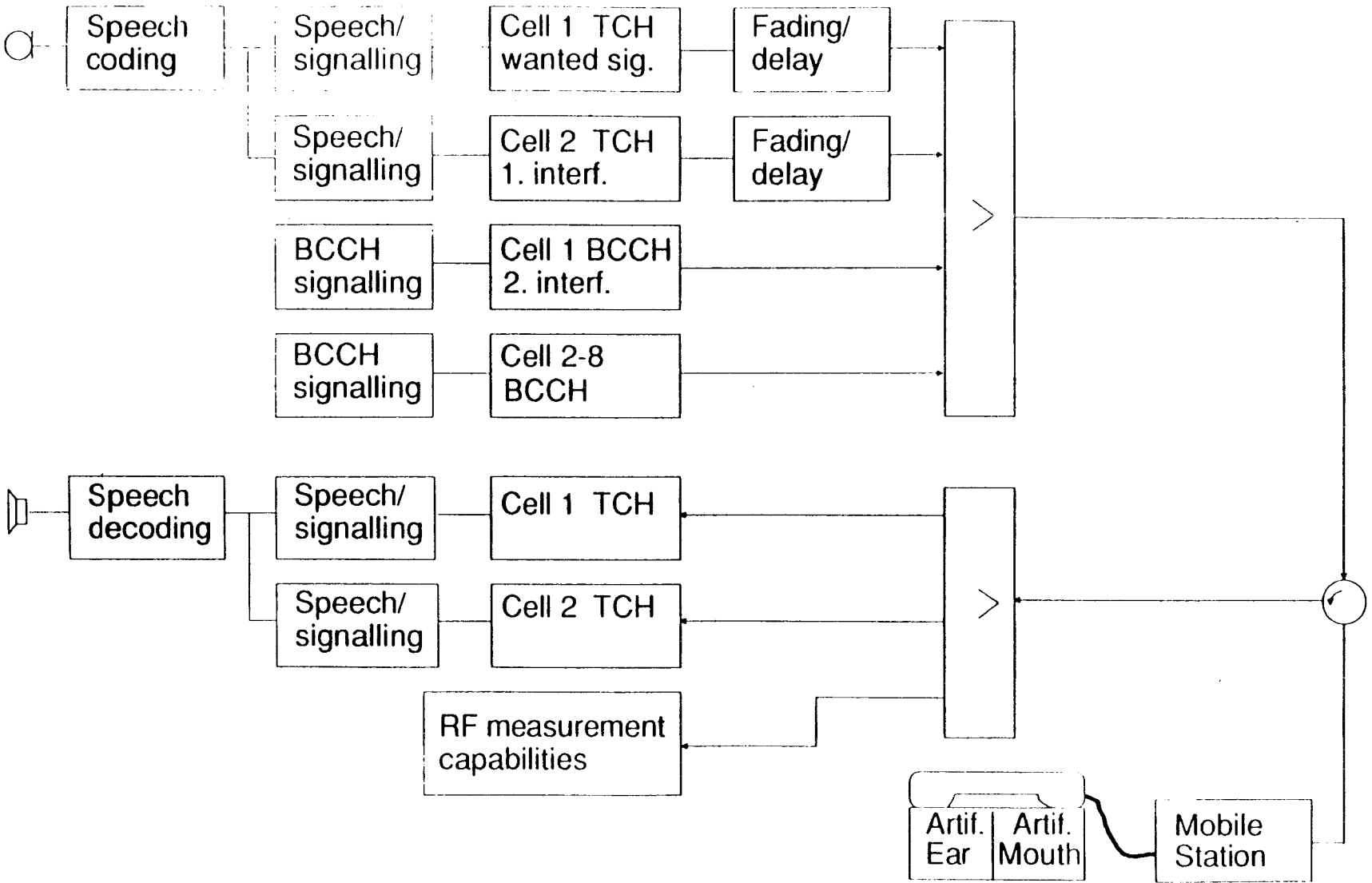

General configuration for some signalling tests and radio measurements

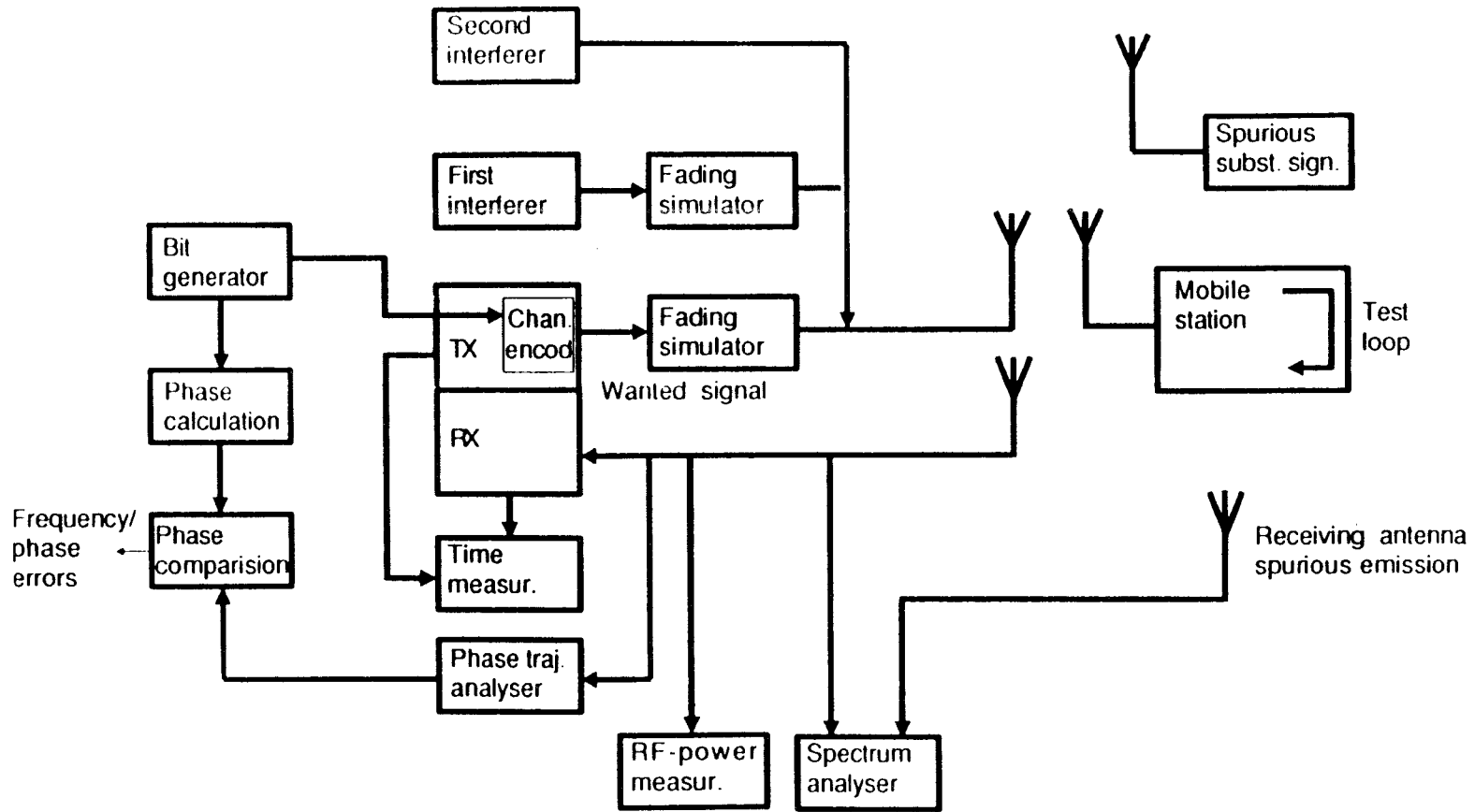

Configuration for Radio Measurements

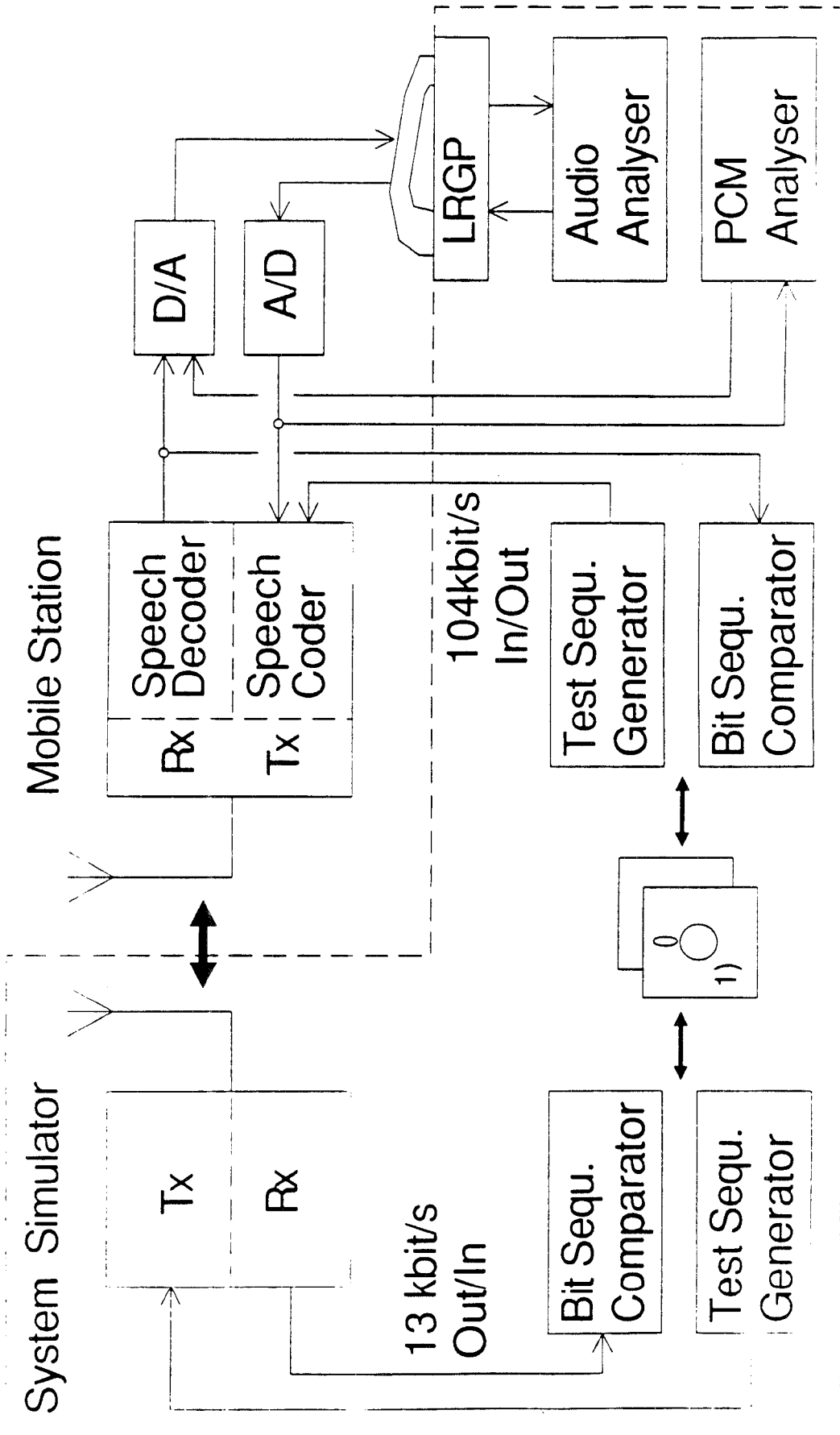

Configuration for MS Speech Codec tests

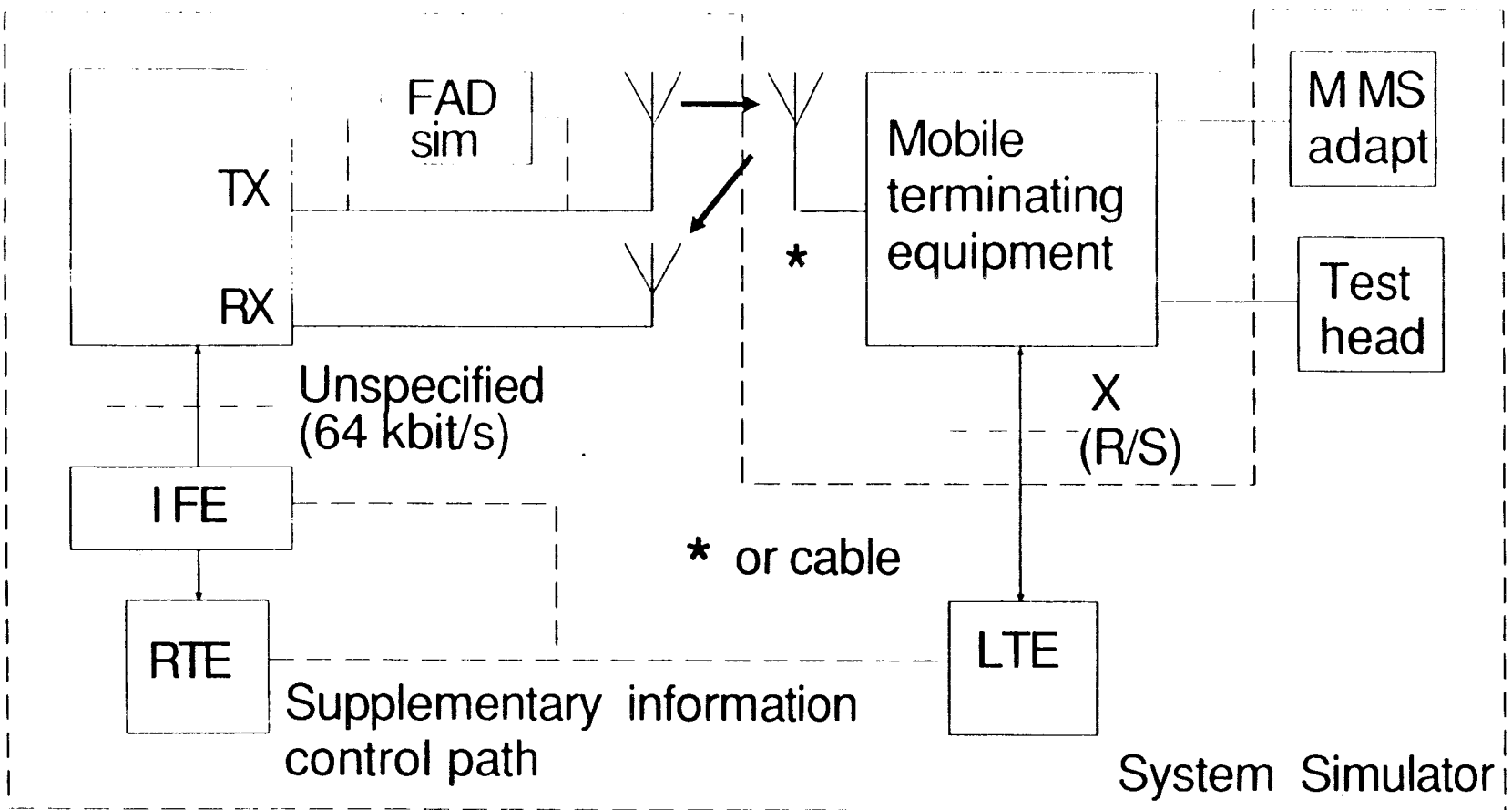

LTE = Local terminal emulator
 RTE = Remote terminal emulator
 IFE = Interworking function emulator

Configuration for tests of user data services

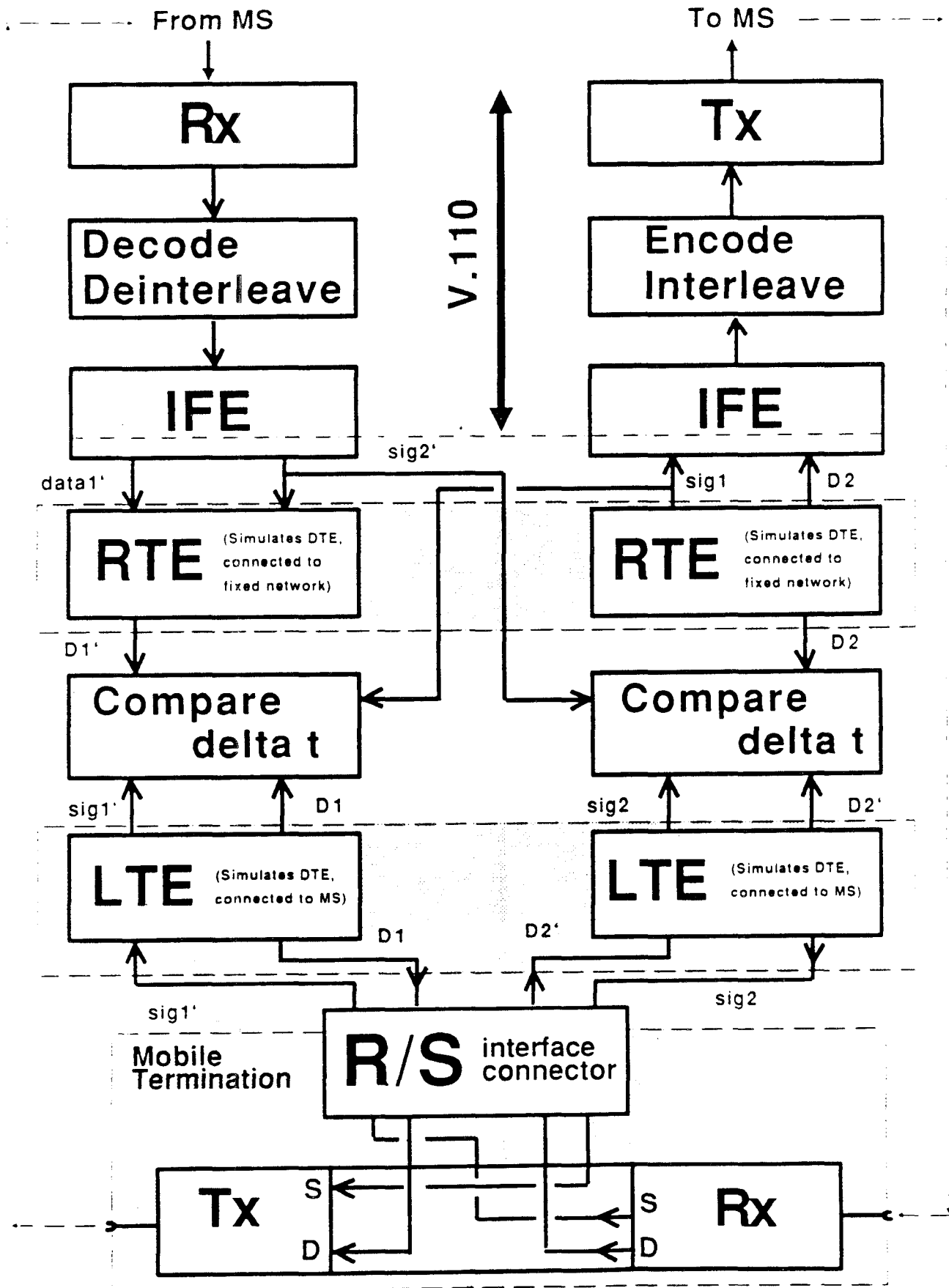

Configuration (part) for tests of user's data services

Appendix 3: TIME MEASUREMENT UNCERTAINTY FOR THE POWER TIME MASK

Rising edge

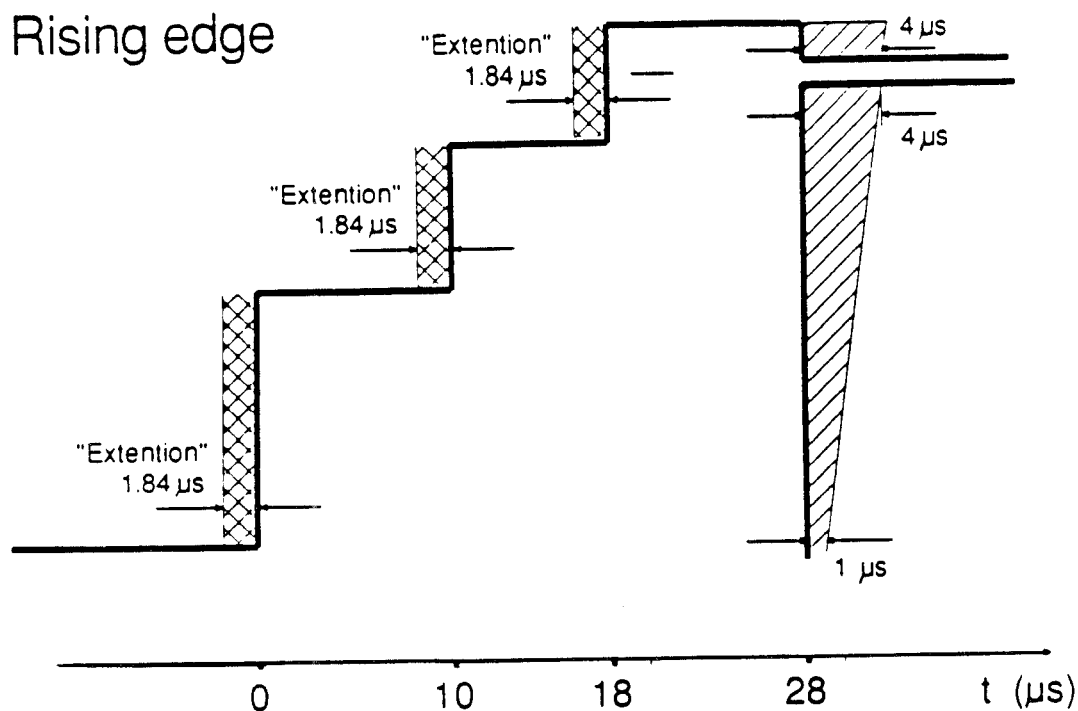

Falling edge

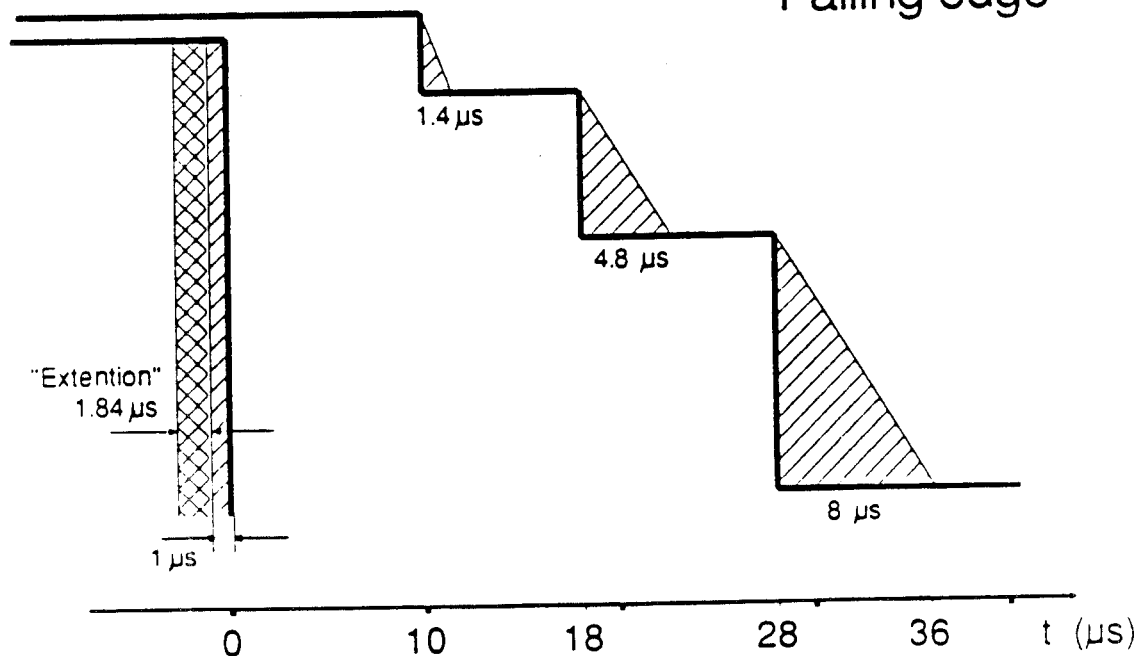

FIGURE App.3-1 / GSM 11.40 :
Time Measurement Uncertainty for the Power Time Mask