

ETSI/TC SMG
Released by : ETSI/PT 12
Release date: February 1992

RELEASE NOTE

Recommendation GSM 08.52

BSC - BTS Interface Principles

Previously distributed version : 3.0.1 (Updated Release 1/90)
New Released version February 92 : 3.0.2 (Release 92, Phase 1)

1. Reason for changes

Only pagenumbering/layout/etc. has been changed since the previously distributed version.

This page is left blank intentionally

ETSI-GSM
Technical
Specification

GSM 08.52

Version 3.0.2

UDC: 621.396.21

Key words: European Digital Cellular Telecommunications System, Global System for Mobile Communications (GSM)

BSC - BTS
Interface
Principles

ETSI

European Telecommunications Standards Institute

ETSI Secretariat: B.P.152 . F - 06561 Valbonne Cedex . France

TP. + 33 92 94 42 00 TF. + 33 93 65 47 16 Tx. 47 00 40 F

Copyright European Telecommunications Standards Institute 1992.
All rights reserved.

No part may be reproduced or used except as authorised by contract or other written permission. The copyright and the foregoing restriction on reproduction and use extend to all media in which the information may be embodied.

PREFATORY NOTE

ETSI has constituted stable and consistent documents which give specifications for the implementation of the European Cellular Telecommunications System. Historically, these documents have been identified as "GSM recommendations".

Some of these recommendations may subsequently become Interim European Telecommunications Standards (I-ETTs) or European Telecommunications Standards (ETTs), whilst some continue with the status of ETSI-GSM Technical Specifications. These ETSI-GSM Technical Specifications are for editorial reasons still referred to as GSM recommendations in some current GSM documents.

The numbering and version control system is the same for ETSI-GSM Technical Specifications as for "GSM recommendations".

ETSI/GSM

GSM Recommendation 08.52

Version 3.0.2

Title: Base Station Controller (BSC) to Base Transceiver Station (BTS) Interface
Interface Principles

Date: February 1992

List of Contents:

1. Scope
2. Definitions
3. General
4. Functional Division Between BSC and BTS
5. Transcoding/Rate Adaption and Multiplexing
6. Interface Structures

Original Language: English

Number of Pages: 15

1. SCOPE

The use and general aspects of the A-bis interface are given in Recommendation GSM 08.51.

This recommendation gives the principle basis for the rest of the recommendations specifying the interface between the Base Station Controller, BSC, and the Base Transceiver Station, BTS, with its transceivers, TRX. These components together form the Base Station System, BSS. (The interface between MSC and the BSS is specified in GSM Recommendations 08.01 - 08.20.)

The intention with this interface is to get a unified way of connecting remotely located BTSs/TRXs to a BSC allowing for the interconnection of BSCs and BTSs/TRXs from different manufacturers.

In order to keep the BTS as simple as possible, BTS contains only those functions which have to reside close to the radio interface.

2. DEFINITIONS

2.1 Base Station System, BSS

See Rec GSM 01.04.

2.2 Base Station Controller, BSC

See Rec GSM 01.04.

2.3 Base Transceiver Station, BTS

See Rec GSM 01.04.

The BTS can consist of one or more TRXs with or without common control equipment.

2.4 Cell

See Rec GSM 01.04.

2.5 Transceiver, TRX

The Transceiver, TRX, in the GSM PLMN is the functional entity which supports the 8 basic radio channels of the same TDMA-frame.

2.6 Base Control Function, BCF

A functional entity which handles common control functions within a BTS, e.g. frequency hopping sequences etc.

At a multi BTS site, one of the BCFs can also be chosen to perform functions common to the site (e.g. external alarms, power supply, time base).

3. GENERAL

Recommendations GSM 08.01 - 08.20 specify the functional split and interface between MSC and the Base Station System, BSS, the A-interface.

The BSS can be further subdivided into one BSC controlling one or more BTSs, each consisting of one or more TRXs. The interface treated by this recommendation is the interface between a BSC and a BTS. It is denoted the A-bis-interface.

The A-bis-interface is capable of supporting three different internal BTS configurations:

- one single TRX,
- a collection of TRXs where all are served by a common physical connection,
- a collection of TRXs, each served by its own physical connection.

Figure 3.1 shows some possible configurations.

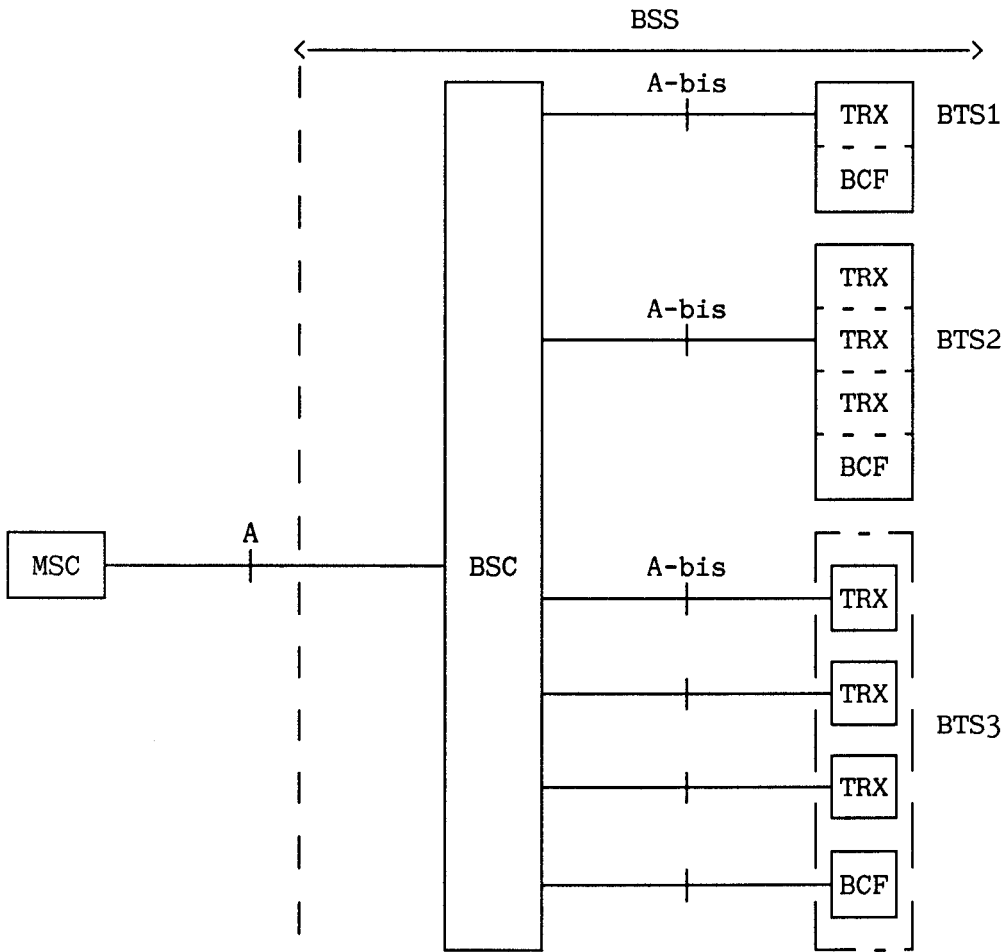

Figure 3.1/08.52. BSS Subdivision and Interfaces.

This recommendation is based on the use of digital transmission system interfaces, either at 2048 kbit/s or at 64 kbit/s. Furthermore, the use of a subrate of 16 kbit/s is supported for coded speech or rate adapted data.

This interface will support the transcoder positioned either inside or outside BTS. In the latter case, remote control (synchronisation) of the transcoder is used.

4. FUNCTIONAL DIVISION BETWEEN BSC AND BTS

4.1 General

In Recommendation GSM 08.02 the functional division between MSC and BSS is described. This section describes the further subdivision of functions between BSC and BTS/TRX required for the A-bis interface. A summary can be found in Table 4.1. Some general requirements on the functionality of the A-bis interface are also specified.

4.2 Terrestrial Channel Management

There is a unique mapping from traffic channels on the radio path to the terrestrial traffic channels. BSC makes the choice of radio channel and thereby also of the terrestrial channel for a call.

4.3 Radio Channel Management

4.3.1 Channel Configuration Management

The channel configuration is controlled between the BSC and OMC. Current configuration is downloaded from OMC to BSC which then controls the use of the radio channels (TDMA time slots for BCCH/CCCH, TCHs, SDCCHs etc).

4.3.2 SDCCH (stand alone DCCH) and TCH Management

4.3.2.1 Frequency hopping management

The hopping sequences for each BTS (cell) is downloaded from OMC to BSC. It is then the responsibility of BSC to download this information to each BTS and also to send the corresponding BCCH information to be transmitted in the BCCH time slots.

4.3.2.2 Channel selection, link supervision and channel release

These functions are controlled by BSC. For channel selection BSC has to have information on blocked radio channels and also on interference level on idle channels.

In the assignment messages to MS (Immediate Assign, Assign Command and Handover Command), a Starting Time parameter is included. This starting time is based on the frame number on the (new) BTS. Before sending the assign message to MS, BSC has to be informed on the current frame number in BTS.

When assigning a channel, BSC shall inform BTS on relevant parameters, e.g. channel type, channel coding, rate adaption, starting time.

4.3.2.3 Power Control

The ordered MS power level is sent in the 16 bit L1-header of SACCH-blocks on the downlink and the actual power level used by MS is reported in the corresponding L1-header on the uplink. This header is inserted (downlink) and extracted (uplink) by BTS/TRX.

The determination of required power level in MS is based on uplink radio measurements made by BTS/TRX and reported to BSC. The basic control of this power is performed by BSC and the dynamic regulation is performed by BSC or optionally by BTS. If BTS supports dynamic MS power regulation, BSC can indicate whether BTS is to regulate the MS power and if so, also the parameters required by BTS.

The required TRX transmission power level on a channel is based on reported measurements performed by MS. The dynamic control of this power is optional. If supported, the basic control is performed by BSC and the dynamic regulation is performed by BSC or optionally by BTS. If BTS supports dynamic TRX transmission power regulation, BSC can indicate whether BTS is to regulate the transmission power and if so, also the parameters required by BTS.

4.3.2.4 Idle channel observation

Idle channels are monitored by BTS.

4.3.3 BCCH/CCCH Management

TRX knows the timing of BCCH/CCCH slots (not known by BSC). The actual timing of BCCH/CCCH blocks therefore has to be made by BTS/TRX, including the scheduling of Paging Request messages on paging sub-channels.

BCCH information is downloaded to BTS.

4.3.4 Random Access

Detection of a random access attempt has to be made by TRX which then sends a message to BSC containing the required timing advance, the frame number of the access attempt and the 8 bit Channel Request message sent by MS in the access burst. This information is then included by BSC in the following Immediate Assign message sent to MS.

4.3.5 Channel Coding/Decoding

The error protection coding and decoding is made by BTS/TRX.

Different coding and interleaving schemes are used for speech and data calls. This information has to be signalled from BSC to BTS on a per call basis.

4.3.6 Transcoding/Rate Adaption

The A-bis interface has to allow for the transcoder/rate adaptor being positioned either inside or outside BTS.

4.3.7 Timing advance

Timing advance has to be determined by TRX.

When MS is on a dedicated channel (SDCCH, TCH), the required timing advance (TA) is sent to MS and the actual timing advance is reported by MS in the 16 bit L1-header of the SACCH blocks.

At handover access, TA is determined by TRX and reported to MS in the PHYSical INFORMATION message sent by BTS/TRX.

At random access, TA is determined by TRX but in those cases, TA has to be reported to BSC for inclusion in the IMMEDIATE ASSIGN message sent to MS by BSC.

4.3.8 Radio Resource Indication

BTS reports on status (interference level, blocking etc.) of idle channels to BSC on a regular basis.

4.3.9 Measurements

MS measures the downlink received level and quality from the serving cell and the received level from surrounding cells. The results from these measurements are reported by MS in Measurement Report messages on SACCH.

Uplink received level and quality are measured by BTS/TRX. The parameters for the uplink measurements are equivalent to the parameters used by MS for the corresponding downlink measurements (averaging period and dynamic range).

The support of forwarding this basic raw measurement data over the A-bis interface is mandatory. Additionally, BTS and BSC may optionally support some pre-processing in BTS of this data.

4.3.10 LAPDm functions (Layer 2)

Layer 2 on the radio interface (LAPDm) is terminated at BTS/TRX. Between BTS and BSC, LAPD is used.

4.3.11 Paging

Paging is initiated by MSC via BSC.

BSC determines the paging group to be used based on IMSI of the MS to be paged. The paging group value is sent to BTS together with the TMSI or IMSI.

Based on the paging group information, BTS/TRX will build the relevant PAGING REQUEST message and execute the transmission of the message in the correct paging sub-channel.

4.3.12 Handover

No handover recognition or decision is made by BTS.

However, BTS/TRX has to detect the handover access made by a handed over MS. BTS/TRX also checks the Handover Reference value sent by MS in the handover access burst against the Handover Reference value received from BSC in the channel activation command. In case of an asynchronous handover, BTS/TRX then builds the PHYSICAL INFORMATION message (including the Timing Advance value) and sends it to MS. The handover access is also reported to BSC.

4.3.13 Encryption

Encryption and decryption is made of the complete outgoing bit stream (except for preambles/synch words). This therefore has to be made by TRX. The encryption key has to be downloaded to BTS/TRX before encryption starts. Special control messages are therefore required between BSC and BTS/TRX.

4.3.14 Mobility Management and Call Control

All mobility management and call control functions reside in MSC.

TABLE 4.1. Summary of functional division between BTS and BSC/MSC

FUNCTION	LOCATION		
	BTS	BSC/MSC	
TERRESTRIAL CHANNEL MANAGEMENT			
MSC-BSC channels			
Channel allocation.....		X	
Blocking indication.....		X	
BSC-BTS channels			
Channel allocation.....		X	
Blocking indication.....	X		
RADIO CHANNEL MANAGEMENT			
Channel configuration management.....		X	
Frequency Hopping			
Management.....		X	
Execution.....	X		
TCH management			
Channel allocation (choice).....		X	
Link supervision.....		X	
Channel release.....		X	
Idle channel observation.....	X		
Power control determination.....	X	X	Note 3
SDCCH management (Stand alone DCCH)			
SDCCH allocation.....		X	
Link supervision.....		X	
Channel release.....		X	
Power control determination.....	X	X	Note 3
BCCH/CCCH management			
Scheduling of messages			
Management.....		X	
Execution.....	X		
Random access			
Access detection.....	X		
Immediate assign (access grant).....	X		
Channel coding/decoding.....	X		
Transcoding/rate adaption.....	X		Note 1
Measurements			
Uplink measuring.....	X		Note 2
Processing of reports from MS/TRX.....	X	X	Note 4
Traffic measurements.....	X		

	BTS	BSC/MSC
Timing advance		
Calculation.....X		
Signalling to MS at random access.....X		
Signalling to MS at handover.....X		
Signalling to MS during call.....X		
Radio resource indication		
Report status of idle channels.....X		
LAPDm functions (Layer 2).....X		
Encryption		
Management.....X		
Execution.....X (Key from BSC)		
Paging		
Initiation.....X		
DRX paging		
Management.....X		
Execution.....X		
Handover		
BSC internal, one cell.....X		
BSC internal, between cells.....X		
BSC external		
recognition, radio reason.....X		
recognition, traffic reason.....X		
decision.....X		
execution.....X		
Handover access detection.....X		
MOBILITY MANAGEMENT		
Authentication.....X		
Location updating.....X		
CALL CONTROL.....X		

Note 1: Although the transcoder is always controlled by the BTS, it can optionally be located outside the BTS (e.g. at the BSC or at the MSC site). In that case, remote control is performed by BTS using inchannel signalling.

Note 2: Including averaging comparable to what is done in the MS.

Note 3: The support of power level determination in BTS is optional.

Note 4: The support of forwarding all raw measurement data from MS/TRX over the A-bis interface and the processing of it in BSC is mandatory. The BTS/BSC may additionally support also some pre-processing in BTS of this raw data.

5. TRANSCODING/RATE ADAPTION AND MULTIPLEXING

The interface supports two options: transcoding/rate adaption performed in BTS or outside BTS.

5.1 Transcoding/Rate Adaption in BTS

The transcoding of speech to normal 64 kbit/s A-law is performed within BTS.

Data may be rate adapted or submultiplexed to 64 kbit/s circuits.

5.2 Transcoding/Rate Adaption outside BTS

In this case the transcoder/rate adaptor is considered as part of the BSC.

The channel coding/decoding is performed by BTS/TRX. The choice of coding/interleaving has to be signalled from BSC to BTS.

The remote speech transcoder has to have knowledge of some radio parameters for an efficient decoding. In addition, the timing of the transcoder has to be aligned with the transmission of the frames over radio such that the frames from BSC arrive synchronized with the transmission over radio (minimizes delay due to remote transcoder). For this control and time alignment of the transcoder, inband signalling is used within a 16 kbit/s channel carrying speech or data, signalling and synchronisation. This remote control of the transcoder is specified in Recommendation GSM 08.60.

For data, rate adaption to subrate 16 kbit/s is performed within BTS.

For the link BTS-BSC, two possibilities are foreseen:

- rate adaption of 16 kbit/s speech + control or 16 kbit/s data + control to 64 kbit/s (one radio traffic channel per 64 kbit/s terrestrial channel),
- multiplexing of 16 kbit/s speech + control or 16 kbit/s data + control into one 64 kbit/s channel (up to four radio traffic channels per 64 kbit/s terrestrial channel).

6. INTERFACE STRUCTURES

6.1 Communication Channels

The A-bis interface is considered to have two types of communication channels (see Figure 6.1):

- traffic channel (SDC) at 16 or 64 kbit/s carrying speech or data of one radio traffic channel (Bm or Lm channel),
- signalling channels (SCH) at 16 or 64 kbit/s, carrying signalling information (both BSC-MS and BSC-BTS signalling).

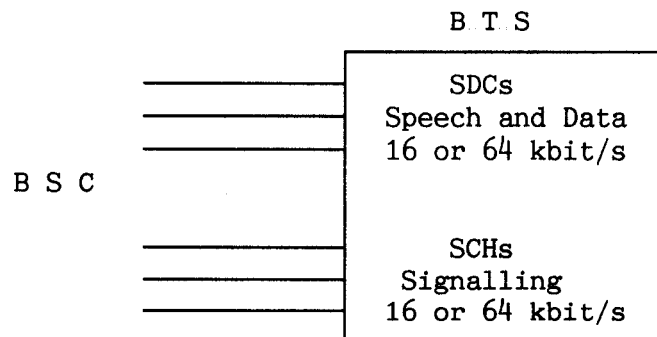

Figure 6.1/08.52. Communication Channel Types

6.2 Signalling Links

The addressing of TRXs and BCF is made using separate TEIs for each TRX and BCF.

Three logical links are defined for each TEI:

RSL:Radio Signalling Link used for supporting traffic management procedures (MS to network communication). One link per TRX.

OML:Operations and Maintenance Link used for supporting network management procedures (transferring operations and maintenance messages). One link per TRX and BCF.

L2ML:Layer 2 Management Link used for transferring layer 2 management messages to TRX or BCF. One link per TRX and BCF.

A logical diagram for the architecture of the signalling links is given in Figure 6.2/08.52.

Only point to point signalling links are used.

SMS messages are also carried on the signalling links.

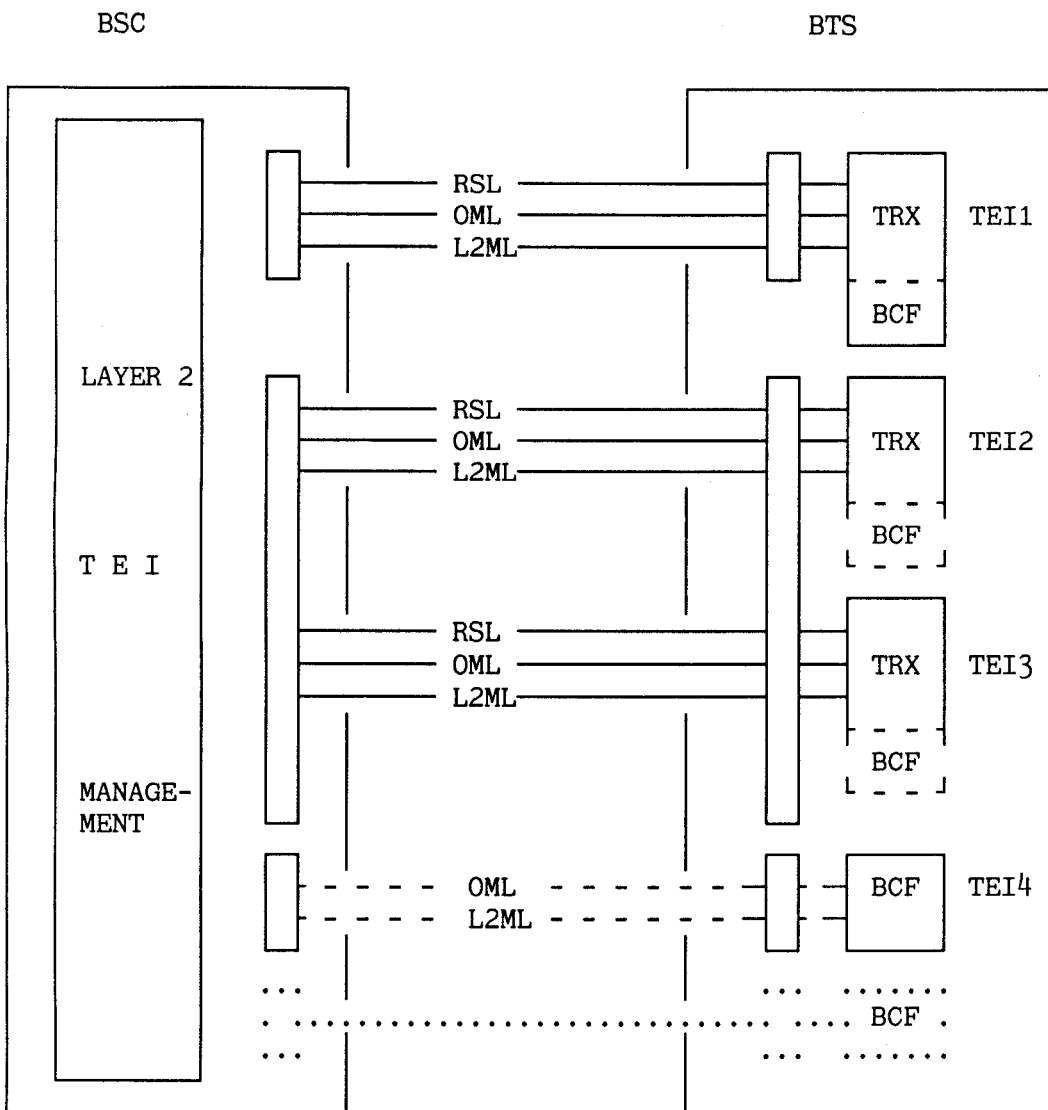

Figure 6.2/08.52 Logical L2 links of A-bis interface.

6.3 Signalling Model

A signalling model for the A-bis interface and its signalling environment can be found in figure 6.3.

CM and MM messages are not interpreted by BSC or BTS. Over the A interface they are transferred using DTAP (Direct Transfer Application Part) and over the A-bis interface they are transferred as transparent messages.

RR messages are mapped to BSSAP (BSS Application Part) in BSC. In BTS, most of them are handled as transparent messages. However, some of them have to be interpreted by BTS (e.g. random access, start cyphering, paging). The BTSM (BTS Management) entities contain procedures for handling these messages and also other procedures for managing the BTS as defined in Recommendation GSM 08.58. In BTS there is a mapping between BTSM and the relevant RR messages over the radio interface (RR').

The Layer 2 protocol over the A-bis interface is based on LAPD. L2 addressing is made to TRX (or BCF) using the TEI of LAPD. Different L2 links are used for traffic management messages (RSL, Radio Signalling Link), network management messages (OML, Operation & Maintenance Link) and L2 management messages (L2ML, Layer 2 Management Link).

A model of Layer 3 for the A-bis interface can be found in figure 6.4.

For traffic management, two types of signalling messages have been defined:

Transparent Messages: Messages which are forwarded by BTS without interpretation or changes.

Non-Transparent Messages: Messages which are sent only between BSC and BTS and which BTS is acting upon or which are the results of BTS actions.

In addition, the messages have been grouped into four main groups: Radio Link Layer Management, Dedicated Channel Management, Common Channel Management and TRX Management messages.

Discrimination between these types and groups is based on the Message Discriminator which is sent as the first octet in all messages. Transparent and non-transparent messages are discriminated by a transparency flag (T-bit) in the Message Discriminator. Transparent messages are merely forwarded to L2 on the radio interface.

In order to address the relevant radio channel, a Channel Number element is included to support the distribution of messages to relevant physical channels on the TRX. A Link Identifier element supports the distribution on logical links/channels on the radio interface (compare the DLCI element of the A interface, Rec 08.06).

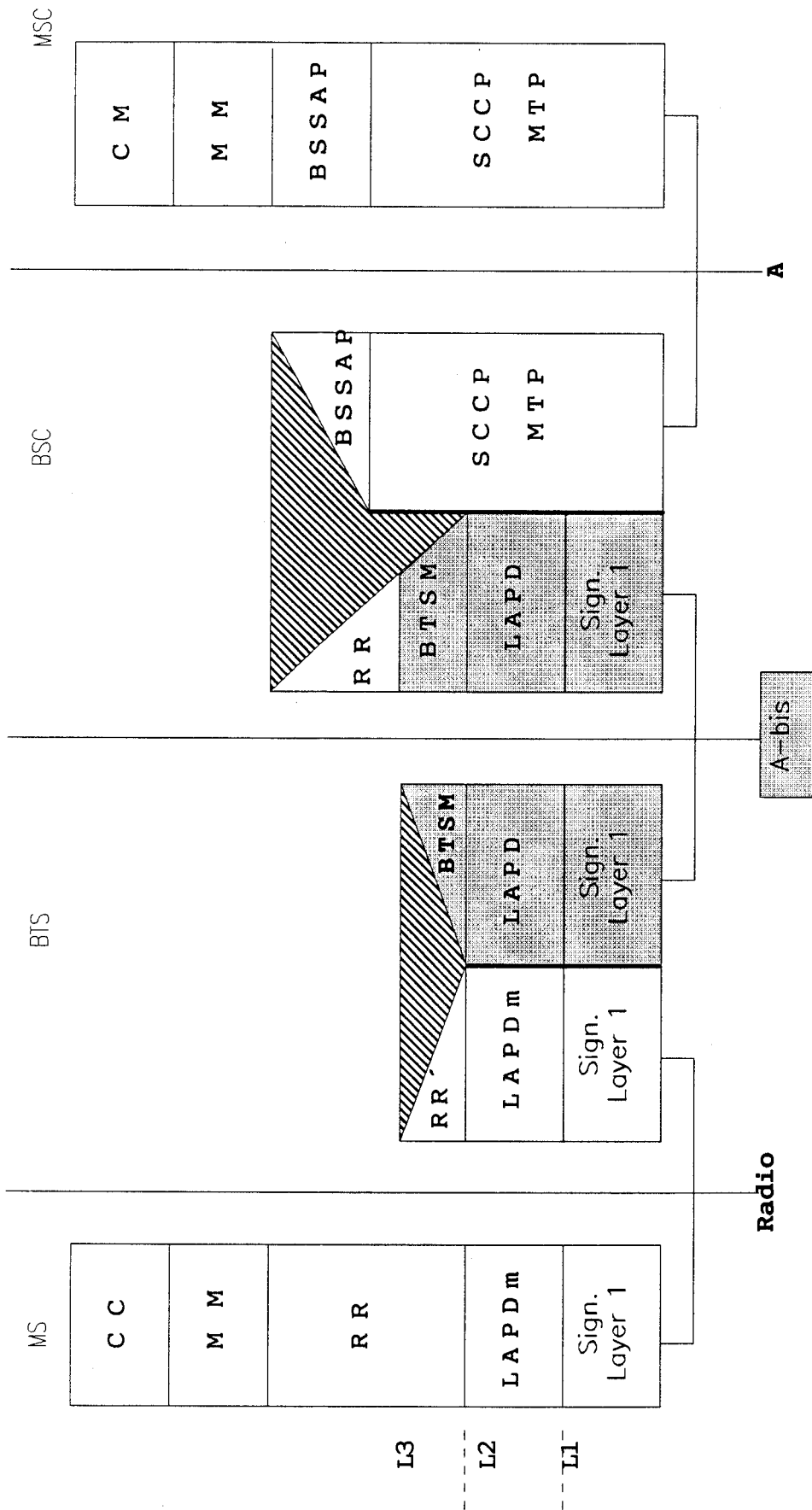

For the radio interface, see GSM 04.xx **BTSM = BTS Management** For the A interface, see GSM 08.02

Figure 6.3/08.52 Signalling model for the A-bis interface and its signalling environment

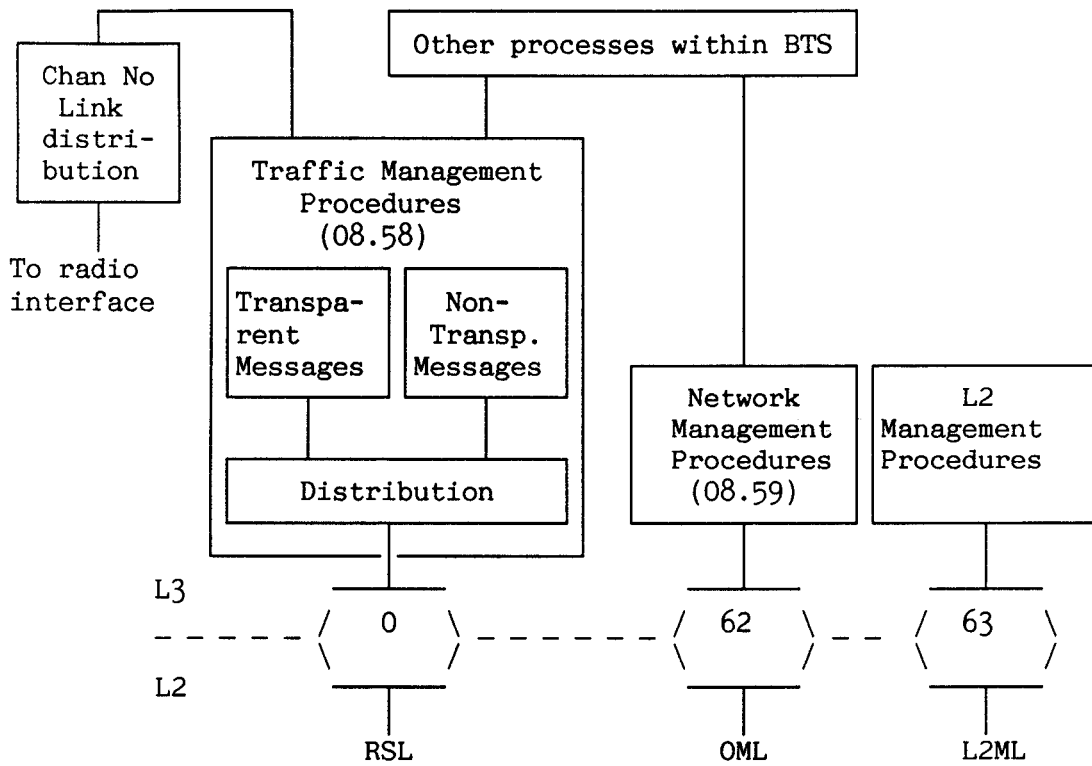

Figure 6.4/08.52 L3 model.

