



GSM TECHNICAL SPECIFICATION

GSM 07.03

May 1996

Version 5.0.0

Source: ETSI TC-SMG

Reference: TS/SMG-040703Q

ICS: 33.060.50

Key words: Digital cellular telecommunications system, Global System for Mobile communications (GSM)

GSM

GLOBAL SYSTEM FOR
MOBILE COMMUNICATIONS

Digital cellular telecommunications system (Phase 2 +); Terminal Adaptation Functions (TAF) for services using synchronous bearer capabilities (GSM 07.03)

ETSI

European Telecommunications Standards Institute

ETSI Secretariat

Postal address: F-06921 Sophia Antipolis CEDEX - FRANCE

Office address: 650 Route des Lucioles - Sophia Antipolis - Valbonne - FRANCE

X.400: c=fr, a=atlas, p=etsi, s=secretariat - **Internet:** secretariat@etsi.fr

Tel.: +33 92 94 42 00 - Fax: +33 93 65 47 16

*

Copyright Notification: No part may be reproduced except as authorized by written permission. The copyright and the foregoing restriction extend to reproduction in all media.

© European Telecommunications Standards Institute 1996. All rights reserved.

Contents

| | | |
|---------------|---|----|
| Foreword..... | | 5 |
| 1 | Scope | 7 |
| 2 | Normative references | 7 |
| 2.1 | Abbreviations | 9 |
| 3 | General | 10 |
| 3.1 | Customer access configuration..... | 10 |
| 3.2 | Terminal Adaptation Function | 10 |
| 3.3 | TAF Interfacing to other MT functions | 10 |
| 4 | Terminal Adaptation Functions for synchronous transparent services..... | 11 |
| 4.1 | Rate Adaptation | 11 |
| 4.1.1 | Rate adaptation - V-series | 11 |
| 4.1.2 | Rate adaptation - X.21 | 11 |
| 4.1.3 | Rate adaptation - S-interface | 11 |
| 4.2 | Interchange Circuit Signalling Mapping | 13 |
| 4.2.1 | V-series interchange circuit mapping..... | 13 |
| 4.2.2 | X.21 Interchange circuit mapping..... | 15 |
| 4.2.3 | Case of S-interface | 16 |
| 4.3 | Call establishment signalling mapping at TE/MT interface | 16 |
| 4.3.1 | V-series interfaces | 16 |
| 4.3.1.1 | Call establishment manual operation - utilising Alternate Speech/Data or Speech followed by Data Capabilities..... | 16 |
| 4.3.1.2 | Call establishment manual operation - utilising the Unrestricted Digital Capability | 17 |
| 4.3.1.3 | V.25bis auto call/auto answer..... | 17 |
| 4.3.2 | X-series interfaces | 18 |
| 4.3.2.1 | X.21bis call establishment manual operation - utilising the Unrestricted Digital Capability | 18 |
| 4.3.2.2 | X.21bis/V.25bis call establishment signalling mapping..... | 18 |
| 4.3.2.3 | X.21 call establishment signalling mapping..... | 18 |
| 4.3.3 | S-interface (I.420) signalling mapping | 18 |
| 4.3.4 | X.25 procedures mapping | 18 |
| 5 | Terminal Adaptation Functions for synchronous non-transparent services..... | 18 |
| 5.1 | Rate Adaptation and protocol model | 19 |
| 5.1.1 | R-interface..... | 19 |
| 5.1.2 | S-interface..... | 19 |
| 5.2 | Signalling Mapping | 20 |
| 5.2.1 | Interchange circuit signalling mapping..... | 20 |
| 5.2.2 | Call establishment signalling mapping..... | 20 |
| 5.3 | Flow Control..... | 20 |
| 5.3.1 | Conditions requiring flow control towards the network | 20 |
| 5.3.2 | Conditional requiring flow control towards TE2..... | 20 |
| 5.3.3 | Local flow control | 21 |
| 5.4 | Buffers | 21 |
| 5.4.1 | TX buffers | 21 |
| 5.4.2 | RX buffers | 21 |
| 6 | V- and S-series interface procedures to 04.08 mapping | 21 |
| 6.1 | Mobile Originated calls | 22 |
| 6.2 | Mobile Terminated calls | 23 |

| | | |
|----------------------|---|----|
| 7 | X.21 interface procedures to 04.08 mapping | 23 |
| 7.1 | X.21 procedures mapping | 23 |
| 7.1.1 | Mobile originated call (see figure 10)..... | 23 |
| 7.1.2 | Mobile terminated call (see figure 10) | 24 |
| 7.1.3 | Mobile termination clearing (see figure 11) | 24 |
| 7.1.4 | Distant end terminal clearing..... | 24 |
| 7.1.5 | Network generated clearing (see figure 11)..... | 25 |
| 7.2 | Dm Signalling causes mapping to X.21 call progress signals..... | 26 |
| 7.3 | X.21 FACILITIES MAPPING | 26 |
| 8 | Support for packet service | 28 |
| 8.1 | Terminal configurations | 28 |
| 8.2 | Support for basic packet access | 29 |
| 8.3 | Support for dedicated packet access..... | 30 |
| Annex A (normative): | L2R Functionality..... | 31 |
| A.1 | Introduction..... | 31 |
| A.2 | L2RBOP | 31 |
| A.3 | Use of the L2RBOP..... | 33 |
| A.3.1 | Radio Link Connection Control..... | 33 |
| A.3.2 | Status transfer | 33 |
| A.3.3 | LAPB connection control | 34 |
| A.3.4 | LAPB exchange identification..... | 34 |
| A.3.5 | Data Transfer | 34 |
| A.3.6 | Flow control..... | 34 |
| History | | 35 |

Foreword

This Global System for Mobile communications Technical Specification (GTS) has been produced by the Special Mobile Group (SMG) Technical Committee (TC) of the European Telecommunications Standards Institute (ETSI).

This GTS defines the interfaces and Terminal Adaptation Functions (TAF) integral to a Mobile Termination (MT) which enables the attachment of synchronous terminals to a MT within the Digital cellular telecommunications system (Phase 2/Phase 2+).

This GTS is a TC-SMG approved GSM technical specification version 5, which contains GSM Phase 2+ enhancements/features to the version 4 GSM technical specification. The European Telecommunications Standard from which this Phase 2+ ETS has evolved is Phase 2 GSM ETS 300 584 (GSM 07.03 version 4.5.1).

The specification from which this GTS has been derived was originally based on CEPT documentation, hence the presentation of this GTS may not be entirely in accordance with the ETSI/PNE rules.

GTS are produced by TC-SMG to enable the GSM Phase 2+ specifications to become publicly available, prior to submission for the formal ETSI standards approval procedure to become European Telecommunications Standards (ETS). This ensures the earliest possible access to GSM Phase 2+ specifications for all Manufacturers, Network operators and implementors of the Global System for Mobile communications.

The contents of this ETS are subject to continuing work within TC-SMG and may change following formal TC-SMG approval. Should TC-SMG modify the contents of this ETS it will then be republished by ETSI with an identifying change of release date and an increase in version number as follows:

Version 5.x.y

where:

- y the third digit is incremented when editorial only changes have been incorporated in the specification;

- x the second digit is incremented for all other types of changes, i.e. technical enhancements, corrections, updates, etc.

Reference is made within this GTS to GSM Technical Specifications (GSM-TS).

NOTE: TC-SMG has produced documents which give the technical specifications for the implementation of the digital cellular telecommunications system. Historically, these documents have been identified as GSM Technical Specifications (GSM-TSs). These TSs may have subsequently become I-ETSs (Phase 1), or ETSs/ETSI Technical Reports (ETRs) (Phase 2). TC-SMG has also produced ETSI GSM TSs which give the technical specifications for the implementation of Phase 2+ enhancements of the digital cellular telecommunications system. These version 5.x.x GSM Technical Specifications may be referred to as GTSS.

Blank page

1 Scope

This specification defines Terminal Adaptation Functions (TAF) which are integrated in a Mobile Termination (MT) and which enable the attachment of Synchronous Terminals to an MT (see GSM 04.02). The general aspects of Terminal Adaptation Functions are contained in specification GSM 07.01. This specification covers support of synchronous data services (see GSM 02.02) for the following interfaces and procedures:

- V.22 DTE/DCE Interface
- V.22bis DTE/DCE Interface
- V.26ter DTE/DCE Interface
- V.32 DTE/DCE Interface
- X.21 DTE/DCE Interface
- X.21bis DTE/DCE Interface
- X.25 Procedure
- X.32 Procedure
- V.25bis Procedure
- I.420 Interface (S)

LAPB is the only synchronous non-transparent protocol which is considered here.

2 Normative references

This ETS incorporates by dated and undated reference, provisions from other publications. These normative references are cited at the appropriate places in the text and the publications are listed hereafter. For dated references, subsequent amendments to or revisions of any of these publications apply to this ETS only when incorporated in it by amendment or revision. For undated references, the latest edition of the publication referred to applies.

- [1] GSM 01.04 (ETR 100): "Digital cellular telecommunication system (Phase 2); Definitions, abbreviations and acronyms".
- [2] GSM 02.02 (ETS 300 501): "Digital cellular telecommunication system (Phase 2); Bearer Services (BS) supported by a GSM Public Land Mobile Network (PLMN)".
- [3] GSM 03.10 (ETS 300 528): "Digital cellular telecommunication system (Phase 2); GSM Public Land Mobile Network (PLMN) connection types".
- [4] GSM 04.02 (ETS 300 551): "Digital cellular telecommunication system (Phase 2); GSM Public Land Mobile Network (PLMN) access reference configuration".
- [5] GSM 04.08 (ETS 300 557): "Digital cellular telecommunication system (Phase 2); Mobile radio interface layer 3 specification".
- [6] GSM 04.21 (ETS 300 562): "Digital cellular telecommunication system (Phase 2); Rate adaption on the Mobile Station - Base Station System (MS - BSS) interface".
- [7] GSM 04.22 (ETS 300 563): "Digital cellular telecommunication system (Phase 2); Radio Link Protocol (RLP) for data and telematic services on the Mobile Station - Base Station System (MS - BSS) interface and the Base Station System - Mobile-services Switching Centre (BSS - MSC) interface".
- [8] GSM 07.01 (ETS 300 582): "Digital cellular telecommunication system (Phase 2); General on Terminal Adaptation Functions (TAF) for Mobile Stations (MS)".

- [9] GSM 08.20 (ETS 300 591): "Digital cellular telecommunication system (Phase 2); Rate adaption on the Base Station System - Mobile-services Switching Centre (BSS - MSC) interface".
- [10] GSM 09.06 (ETS 300 603): "Digital cellular telecommunication system (Phase 2); Interworking between a Public Land Mobile Network (PLMN) and a Packet Switched Public Data Network/Integrated Services Digital Network (PSPDN/ISDN) for the support of packet switched data transmission services".
- [11] GSM 09.07 (ETS 300 604): "Digital cellular telecommunication system (Phase 2); General requirements on interworking between the Public Land Mobile Network (PLMN) and the Integrated Services Digital Network (ISDN) or Public Switched Telephone Network (PSTN)".
- [12] CCITT Series V Recommendations: "Data communication over the Telephone network".
- [13] CCITT Series X Recommendations: "Data communication networks".
- [14] CCITT Recommendation V.10: "Electrical characteristics for unbalanced double-current interchange circuits for general use with integrated circuit equipment in the field of data communications".
- [15] CCITT Recommendation V.11: "Electrical characteristics for balanced double-current interchange circuits for general use with integrated circuit equipment in the field of data communications".
- [16] CCITT Recommendation V.25: "Automatic answering equipment and/or parallel automatic calling equipment on the general switched telephone network including procedures for disabling of echo control devices for both manually and automatically established calls".
- [17] CCITT Recommendation V.25 bis: "Automatic Calling and/or Answering Equipment on the General Switched Telephone Network (GSTN) using the 100-series interchange circuits".
- [18] CCITT Recommendation V.28: "Electrical characteristics for unbalanced double-current interchange circuits".
- [19] CCITT Recommendation V.110: "Support of data terminal equipments (DTEs) with V-Series interfaces by an integrated services digital network".
- [20] CCITT Recommendation V.24: "List of definitions for interchange circuits between data terminal equipment (DTE) and data circuit-terminating equipment".
- [21] CCITT Recommendation X.24: "List of definitions for interchange circuits between Data Terminal Equipment (DTE) and Data Circuit Terminating Equipment (DCE) on Public Data Networks".
- [22] CCITT Recommendation X.25: "Interface between Data Terminal Equipment (DTE) and Data Circuit Terminating Equipment (DCE) for terminals operating in Packet Mode and connected to Public Data Networks by dedicated Circuit".
- [23] CCITT Recommendation X.21: "Interface between Data Terminal Equipment (DTE) and Data Circuit Terminating Equipment (DCE) for synchronous operation in public data networks".
- [24] CCITT Recommendation X.21 bis: "Use on public data networks of data terminal equipment (DTE) which is designed for interfacing to synchronous V-Series modems".

- [25] CCITT Recommendation X.26: "Electrical characteristics for unbalanced double-current interchange circuits for general use with integrated circuit equipment in the field of data communications".
- [26] CCITT Recommendation X.27: "Electrical characteristics for balanced double-current interchange circuits for general use with integrated circuit equipment in the field of data communications".
- [27] CCITT Recommendation X.30: "Support of X.21, X.21bis and X.20bis based Data Terminal Equipment (DTEs) by an ISDN".
- [28] CCITT Recommendation X.31: "Support of Packet Mode Terminal Equipment in ISDN".
- [29] CCITT Recommendation X.32: "Interface between Data Terminal Equipment (DTE) and Data Circuit Terminating Equipment (DCE) for terminals operating in Packet Mode and accessing a PSPDN through a PSTN or an ISDN or a CSPDN".
- [30] CCITT Recommendation I.461: "Support of X.21, X.21bis and X.20bis based data terminal equipment (DTEs) by integrated services digital network (ISDN)".
- [31] CCITT Recommendation I.463: "Support of data terminal equipment (DTEs) with V-Series type interfaces by an integrated services digital network (ISDN)".
- [32] ISO Recommendation 8885: "Information technology - Telecommunication and information exchange between systems - High-level data link control (HDLC) procedures - General purpose XID frame information field content and format".
- [33] ISO Recommendation 8886: "Information technology - Telecommunication and information exchange between systems - Data link service definitions for Open Systems interconnection".
- [34] Personal Computer Memory Card Association: "PCMCIA 2.1 or PC-Card 3.0 electrical specification or later revisions".
- [35] IrDA "IrPHY Physical signalling standard".
- [36] TIA-617: "Data Transmission Systems and Equipment - In-Band DCE Control".

2.1 Abbreviations

In addition to those below abbreviations used in this specification are listed in GSM 01.04.

AU Access Unit
PF Packet Function

3 General

3.1 Customer access configuration

The GSM PLMN access reference configuration is described in figure 1 of GSM 04.02. This specification (GSM 07.03) specifically refers to the MTs which support terminal equipments (TE1 or TE2) that use synchronous bearer capabilities.

3.2 Terminal Adaptation Function

The TAF is functionally part of an MT0, MT1 or MT2 (see specification GSM 04.02). The terminal adaptation provides facilities to allow manual or automatic call control functions associated with alternate speech/data, speech followed by data and circuit switched data services, in case of V series interfaces. The X.21 DTE/DCE interface allows only for automatic call control functions. The following functions are included:

- Conversion of electrical, mechanical, functional and procedural characteristics of the V-series, X-series and ISDN type interfaces to those required by a GSM PLMN.
- Bit rate adaptation of V-series and X-series data signalling rates and the ISDN 64 kbit/s to that provided in the GSM PLMN.
- The mapping of V.25bis AUTO CALL/AUTO ANSWER procedures and X.21 procedures to the GSM PLMN Dm-channel signalling.
- The mapping functions necessary to convert S-interface signalling to PLMN Dm-channel signalling.
- Synchronization procedure, which means the task of synchronizing the entry to and the exit from the data transfer phase between two subscriber terminals. This is described in the specification GSM 07.01.
- Filtering of channel control information. This is described in the specification GSM 07.01.
- Compatibility checking (see GSM 07.01)
- Layer 2 relaying (see Annex 1)
- Flow control
- In Call Modification function (see section 4)

3.3 TAF Interfacing to other MT functions

TAF interfacing is shown in figure 1.

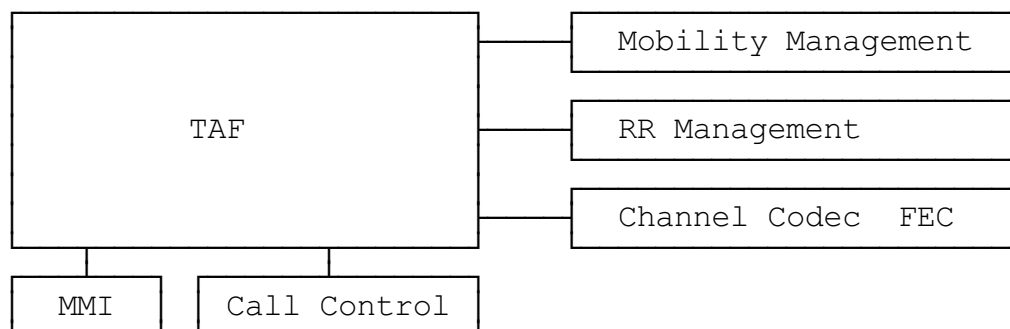

Figure 1: TAF interfacing to other MT functions

4 Terminal Adaptation Functions for synchronous transparent services

Specification GSM 03.10 refers to the models for connection types supporting synchronous transparent services.

4.1 Rate Adaptation

Rate adaptation on the MS-BS interface is described in GSM 04.21. The synchronous data services make use of the following rate adaptation functions: RA1, RA2, RA1/RA1' and RA1'. See also Figure 6 in GSM 03.10. The D-bits of the rate adaptation frames are used to convey user data and the S- and X-bits are used to convey channel status information associated with the data bits in the data transfer state. For the S- and X-bits, a ZERO corresponds to the ON condition, a ONE to the OFF condition.

4.1.1 Rate adaptation - V-series

This is provided as indicated in specification GSM 04.21. The functions applied in this case are shown in figure 2 (see model 2b in Fig. 6/GSM 03.10).

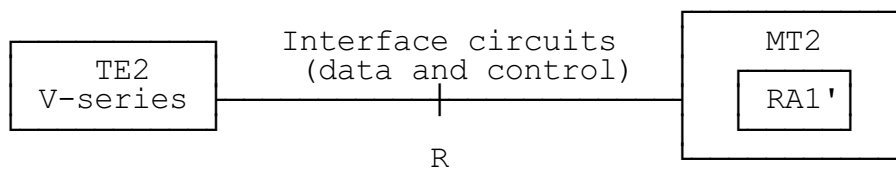

Figure 2: Rate adaptation for V-series terminals

4.1.2 Rate adaptation - X.21

This is provided as indicated in specification GSM 04.21. The functions applied in this case are shown in figure 3 (see model 2b in Fig. 6/GSM 03.10).

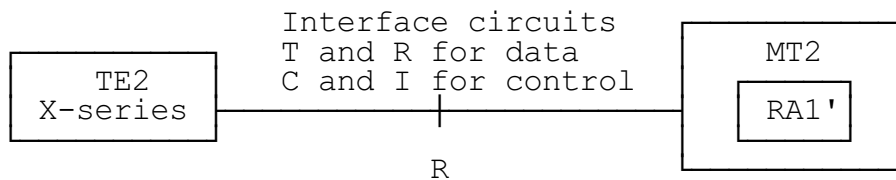

Figure 3: Rate adaptation for X.21 terminals

4.1.3 Rate adaptation - S-interface

The functions applied in this case are shown in figure 4 (see model 2a in Fig. 6 / GSM 03.10).

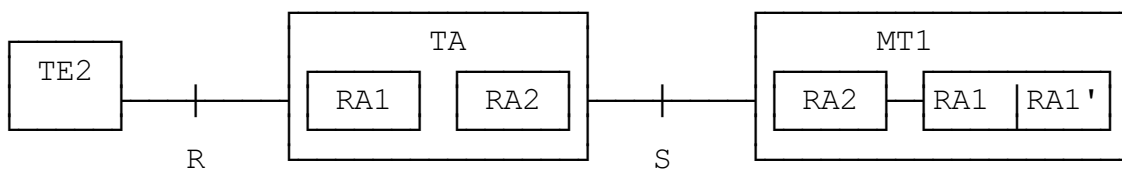

Figure 4a: Rate adaptation for S-interface

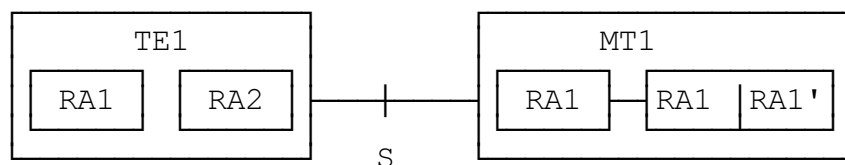

Figure 4b: Rate adaptation for S-interface (continued)

There are two cases to be considered for the RA1 function:

- a) V-series interface
 For the V-series type of terminal equipments the rate adaptation functions are as described in GSM 04.21.
- b) X.21-interface
 For terminal equipments using the X.21-interface the rate adaptation functions are identical to those described in GSM 04.21, but the notation used is as described in CCITT recommendation X.30/I.461.

The notation used is as follows:

The conversion of the user rates of 2.4 and 4.8 kbit/s to 8 kbit/s and user rate of 9.6 kbit/s to 16 kbit/s shall be implemented by means of the 40 bit frame structure shown in figure 5.

Figure 5 shows that in addition to the basic frame, a two frame multiframe is employed. In odd frames, octet 0 contains all zeros, whilst in even frames octet 0 consists of a one followed by seven E bits. The order of bit transmission of the 40 bit frame is from left-to-right and top-to-bottom.

This two frame multiframe corresponds to the 80 bit frame structure presented in GSM 04.21 as shown in figure 6. The 24 information bits P1,...,P8, Q1,..,Q8, R1,...,R8 of odd frames correspond with D1,...,D24 and those of even frames correspond with D25,...,D48 respectively. For the status bits there is the following correspondence: odd frame SQ,X,SR,SP = S1,X,S3,S4 and even frame SQ,X,SR,SP = S6,X,S8,S9.

Option for a manufacturer of mobile stations:

In transparent mode support of a packet mode TE1 or TE2/TA, which uses flag stuffing.

| | | Bit number | | | | | | | |
|---------|-------------|------------|----|----|----|----|----|----|----|
| | | 1 | 2 | 3 | 4 | 5 | 6 | 7 | 8 |
| Octet 0 | Odd frames | 0 | 0 | 0 | 0 | 0 | 0 | 0 | 0 |
| | Even frames | 1 | E1 | E2 | E3 | E4 | E5 | E6 | E7 |
| Octet 1 | | 1 | P1 | P2 | P3 | P4 | P5 | P6 | SQ |
| Octet 2 | | 1 | P7 | P8 | Q1 | Q2 | Q3 | Q4 | X |
| Octet 3 | | 1 | Q5 | Q6 | Q7 | Q8 | R1 | R2 | SR |
| Octet 4 | | 1 | R3 | R4 | R5 | R6 | R7 | R8 | SP |

NOTE: Bit X, if not used for the optional flow control or for the indication of the far end synchronization, shall be set to 0 (see CCITT Rec. I.463/V.110).

Figure 5: 40 bit frame structure of CCITT X.30

| | <u>X.30 Two frame multifr.</u> | | | | | | | | <u>V.110 80-bit frame</u> | | | | | | | |
|---------------|--------------------------------|----|----|----|----|----|----|----|---------------------------|-----|-----|-----|-----|-----|-----|----|
| odd frame | 0 | 0 | 0 | 0 | 0 | 0 | 0 | 0 | 0 | 0 | 0 | 0 | 0 | 0 | 0 | 0 |
| | 1 | P1 | P2 | P3 | P4 | P5 | P6 | SQ | 1 | D1 | D2 | D3 | D4 | D5 | D6 | S1 |
| | 1 | P7 | P8 | Q1 | Q2 | Q3 | Q4 | X | 1 | D7 | D8 | D9 | D10 | D11 | D12 | X |
| | 1 | Q5 | Q6 | Q7 | Q8 | R1 | R2 | SR | 1 | D13 | D14 | D15 | D16 | D17 | D18 | S3 |
| | 1 | R3 | R4 | R5 | R6 | R7 | R8 | SP | 1 | D19 | D20 | D21 | D22 | D23 | D24 | S4 |
| even frame | 1 | E1 | E2 | E3 | E4 | E5 | E6 | E7 | 1 | E1 | E2 | E3 | E4 | E5 | E6 | E7 |
| | 1 | P1 | P2 | P3 | P4 | P5 | P6 | SQ | 1 | D25 | D26 | D27 | D28 | D29 | D30 | S6 |
| | 1 | P7 | P8 | Q1 | Q2 | Q3 | Q4 | X | 1 | D31 | D32 | D33 | D34 | D35 | D36 | X |
| | 1 | Q5 | Q6 | Q7 | Q8 | R1 | R2 | SR | 1 | D37 | D38 | D39 | D40 | D41 | D42 | S8 |
| | 1 | R3 | R4 | R5 | R6 | R7 | R8 | SP | 1 | D43 | D44 | D45 | D46 | D47 | D48 | S9 |

Figure 6: Correspondence of X.30 and V.110 frames

4.2 Interchange Circuit Signalling Mapping

4.2.1 V-series interchange circuit mapping

The interchange circuit signalling mapping at the interface between the TE2 and the MT shall conform to CCITT recommendation V.24; while the signal levels at the interface shall conform either to CCITT recommendation V.28, or to IrDA IrPHY Physical signalling standard specification, or to PCMCIA 2.1, or to PC-Card 3.0 electrical specifications or to later revisions.

The signals required at this interface are shown in Table 2.

Specification 04.21 refers to the frame structure and identifies the use of status bits for the carriage of signalling information.

Status bits

The bits S and X are used to convey channel status information associated with the data bits in the data transfer stage as shown below. The S-bits are put into two groups SA and SB to carry the condition of two interchange circuits. The X-bit is used to control the condition of circuit 106.

The mechanism for proper assignment of the control information from the transmitting signal rate adapter interface via these bits to the receiving signal rate adapter interface is shown below in Table 1.

For the S and X bits, a ZERO corresponds to the ON condition, a ONE to the OFF condition.

General mapping scheme

Table 1: General mapping scheme for V-series interchange circuits

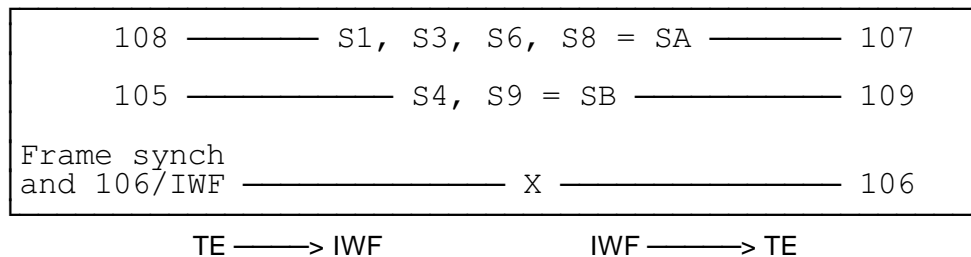

Table 2: Minimum set of V-series interchange circuits

| Circuit Number | Circuit Name | Ground | Data | | Control | |
|----------------|--|--------|--------|----------|---------|----------|
| | | | to TE2 | from TE2 | to TE2 | from TE2 |
| CT102 | Common Return | X | | | | |
| CT103 | Transmitted data | | | X | | |
| CT104 | Received data | | X | | | |
| CT105 | Request to send | | | | | X |
| CT106 | Ready for sending | | | | X | |
| CT107 | Data set ready | | | | X | |
| CT108.2 | Data terminal ready | | | | | X |
| CT109 | Data channel received line signal detector | | | | X | |
| CT114 | Transmitter signal element timing | | | | X | |
| CT115 | Receiver signal element timing | | | | X | |
| CT125 | Calling indicator (Note) | | | | X | |

NOTE: CT125 is used with the AUTO ANSWER function of the TAF.

Use of Network Independent Clocking:

Network Independent Clocking is only applicable to calls using ITC value "3.1 kHz audio ex PLMN".

Within the GSM network the coding of the values for bits associated with NIC is specified in GSM specifications 04.21/08.20. In the forward (transmitting) direction the multiframes shall be coded in exact accordance with that specified in those specifications. Bit E6 is set to "1" in alternate modified V.110 frames at the transmitter. However, the use of this bit at the receiver for monitoring frame Synchronisation, or any other purpose, is not specified and is left to the discretion of the implementor.

A "perfect linear block Code" is used in C1-C5, whose error correction properties may be utilised in the receiver, in order to ensure reliable operation of NIC.

The NIC sending function has to recognise when the difference between the applicable clock speed of the GSM network and the interface speed generates a positive or negative whole bit requirement. When this positive or negative condition occurs, the NIC codewords specified in specification GSM 04.21 are used to transport this condition to the receiving NIC function. Transmission of the codeword shall clear the positive or negative condition related to that codeword at the sending function. The sending function shall not send more than one positive or negative compensations within a contiguous period of time corresponding to 10000 user data bits minus the number of user data bits necessary to make up an even number of V.110

frames between compensations (NIC compensation is coded in two V.110 frames). This results from the requirements to compensate for maximum clock differences of ± 100 parts per million. If the receiving function receives NIC compensations more often than a contiguous period of time corresponding to 10000 user data bits, there is no guarantee that data will not be lost.

The NIC receiving function has to provide the capability to support the compensation requirements of the sending function. This compensation is managed by manipulating the clock speed of the interface, within the standard constraints of that interface.

Overall, the compensation functions have to be capable of managing clock tolerances of ± 100 parts per million.

The NIC function has to recognize and manage the conversion of the NIC information received incoming from an ISDN terminal Interface. The conversion has to be made to the NIC format used within the GSM System as defined in specifications 04.21/08.20. The NIC function has to manage the conversion of the GSM NIC format into that used within the ISDN in the traffic direction towards the ISDN terminal interface.

Due to the incompatibility between the ISDN and the GSM requirements NIC interworking is not provided between these two formats. As such no NIC function is required in providing interworking to the ISDN for unrestricted digital.

Action on loss of synchronisation:

If five consecutive NIC multiframes have incorrect framing bit values in E7, the receiver shall stop applying clocking compensation to the received data. Resynchronisation will be attempted and compensation will resume when synchronisation is achieved.

Signal element timing:

Receiver signal element timing (CT115) is generated by MT2. In the transparent case, this shall be synchronized to the output of RA1' function. In the non transparent case it is output from the L2R on the basis of the current user data rate. A transition from ON to OFF condition shall nominally indicate the centre of each signal element on CT104.

Transmitter signal element timing is generated by MT2 (CT114), this may be synchronized to CT115.

In the case of alternate Speech/Group 3 Facsimile, there may be a Channel Mode Modify during the course of the facsimile portion of the call. If this occurs, the user data rate changes and this is reflected to the V.24 interface as a change in the clock speed on CT 114 and CT 115.

4.2.2 X.21 Interchange circuit mapping

The interchange circuit signalling mapping at the interface between the TE2 and the MT shall conform to CCITT recommendations X.21 and X.24; while the signal levels at the interface shall conform either to CCITT recommendation X.26 (v.10), or to X.27 (V.11) - see also paragraph 2.1 of CCITT recommendation X.21, or to IrDA IrPHY Physical signalling standard specification, or to PCMCIA 2.1, or to PC-Card 3.0 electrical specifications or to later revisions.

The signals required at this interface are shown in Table 3.

Specification 04.21 refers to the frame structure and identifies the use of status bits for the carriage of signalling information.

Status bits (S1,S3,S4,S6,S8,S9):

For the purpose of alignment with the case where the X.21 TE2 is connected to the MT via a TA conforming to CCITT recommendation X.30 (I.461), the notation for the S-bits will be SP, SQ and SR as in Figure 5/GSM 07.03. For the bits SP, SQ and SR, a ZERO corresponds to the ON condition, a ONE to the OFF condition.

The bits SP, SQ and SR are used to convey channel associated status information. The mapping of the information on circuit C of the X.21 interface to the S bits and from the S bits to the circuit I in the distant interface should be done in such a way that the SP, SQ and SR bits are associated with the bit-groups P, Q and R. To assure proper and secure operation the mapping scheme has to be consistent with CCITT recommendations X.21 and X.24.

The mechanism for mapping is as follows:

- In all cases where X.21-byte timing interchange circuit B is not provided, the status bits SP, SQ and SR of the bit groups P, Q and R are evaluated by sampling the circuit C in the middle of the 8th bit of the respective preceding bit group. On the other hand, the conditions of the status bits SP, SQ and SR are adopted by the circuit I beginning with transition of the respective 8th bit of a bit-group P, Q and R to the first bit of the consecutive bit group on the circuit R.
- In the case where X.21-byte timing interchange circuit B is provided for character alignment, the circuit C is sampled together with the bit 8 of the preceding octet and the circuit I is changing its state at the boundaries between the old and new octets at the circuit R. This operation is defined in CCITT recommendation X.24.

Table 3: X.21 interchange circuits

| Inter-change circuit | Interchange circuit name | Data | | Control | | Timing to TE2 |
|----------------------|--------------------------|--------|----------|---------|----------|---------------|
| | | to TE2 | from TE2 | to TE2 | from TE2 | |
| G | Common return | | | | | |
| Ga | TE2 common return | | | | X | |
| T | Transmit | | X | | | |
| R | Receive | X | | | | |
| C | Control | | | | X | |
| I | Indication | | | X | | |
| S | Signal element timing | | | | | X |
| B | Byte timing (note) | | | | | X |

NOTE: According to CCITT recommendation X.21 the provision of the 8 bit timing interchange circuit B is not mandatory.

4.2.3 Case of S-interface

At the S-interface an X.30 rate adapted bit stream is provided by the TE1 or TE2-TA combination (see Fig. 4). The terminal adaptation function within the MT does not have any interchange circuit signalling mapping function to perform.

4.3 Call establishment signalling mapping at TE/MT interface

4.3.1 V-series interfaces

4.3.1.1 Call establishment manual operation - utilising Alternate Speech/Data or Speech followed by Data Capabilities

During manual call establishment, the mobile user shall be able to hear network supervisory tones and answer tone.

On hearing answer tone, the user invokes the transition from speech to data in both Mobile Station and the IWF. The mapping for this is shown in section 6.

4.3.1.2 Call establishment manual operation - utilising the Unrestricted Digital Capability

In this case the user will not hear network supervisory tones or answer tone. The data transfer phase will be entered automatically.

4.3.1.3 V.25bis auto call/auto answer

The mapping of the V.25bis procedures to the messages of the PLMN Dm-channel signalling (GSM 04.08) is defined in section 4.

Auto Call:

This procedure is provided according to V.25bis using only circuit 108/2. A subset of V.25bis is shown in Table 4. This subset gives minimum level of control and indication.

During the call establishment phase, i.e. after signalling, call tone according to V.25bis shall be generated in the IWF, where appropriate.

Auto Answer:

This procedure is provided according to V.25bis.

Table 4: Minimum set of V.25bis Call Set-up Commands and Indications

| | Description | IA5Characters |
|--------------------|--|---------------|
| Commands from TE2 | <u>C</u> all <u>R</u> equest with <u>N</u> umber provided 0,1..9,*,#,A,B,C,D | CRN |
| | <u>D</u> isregard <u>I</u> ncoming <u>C</u> all | DIC |
| | <u>C</u> onnect <u>I</u> ncoming <u>C</u> all | CIC |
| Indications to TE2 | <u>C</u> all <u>F</u> ailure <u>I</u> ndication XX = CB,AB,NT,FC (Note) | CFI XX |
| | <u>I</u> ncoming <u>C</u> all | INC |
| | <u>V</u> ALid | VAL |
| | <u>I</u> NValid | INV |

NOTE: to table 4: CB = Local MT busy
 AB = Abort call
 NT = No answer
 FC = Forbidden call *

* Forbidden call indication results from contravention of rules for repeat call attempts as defined by the appropriate national approvals administration. It is recommended that this is the responsibility of the MT, not the TE2.

4.3.2 X-series interfaces

4.3.2.1 X.21bis call establishment manual operation - utilising the Unrestricted Digital Capability

In this case the user will not hear network supervisory tones or answer tone. The data transfer phase will be entered automatically.

4.3.2.2 X.21bis/V.25bis call establishment signalling mapping

The mapping of the V.25bis procedures to the messages of the PLMN Dm-channel signalling (GSM 04.08) is defined in section 6.

Auto Call:

This procedure is provided according to V.25bis using only circuit 108/2. A subset of V.25bis is shown in Table 4. This subset gives minimum level of control and indication.

Auto Answer:

This procedure is provided according to V.25bis.

4.3.2.3. X.21 call establishment signalling mapping

The mapping of the X.21 procedures to the messages of the PLMN Dm-channel signalling (GSM 04.08) is defined in section 7.

4.3.3. S-interface (I.420) signalling mapping

The mapping of Q.931 signalling to 04.08 signalling requires the inclusion, by the MT, of PLMN specific elements (eg. transparent or not, half or full rate channel). The required Bearer Capability Elements are shown in GSM 07.01 Annex 2.

4.3.4. X.25 procedures mapping

User terminals are connected to mobile termination either at S reference point (TE1 or TE2/TA) or at R reference point (TE2). For the physical interface of TE2s all different possibilities are shown in table 9 in section 8.

For more details, see CCITT X.25 and the appropriate interface recommendations.

The mapping is described in section 8.

5 Terminal Adaptation Functions for synchronous non-transparent services

This section deals with the specific requirements for non-transparent X.25 access. Other cases, e.g. teletex, are dealt within other specifications.

Layer 2 Relay function is described in Annex 1.

5.1 Rate Adaptation and protocol model

5.1.1 R-interface

Figure 7 describes the protocol model and rate adaptation function applied in this case (see Model 4b of Figure 6/GSM 03.10).

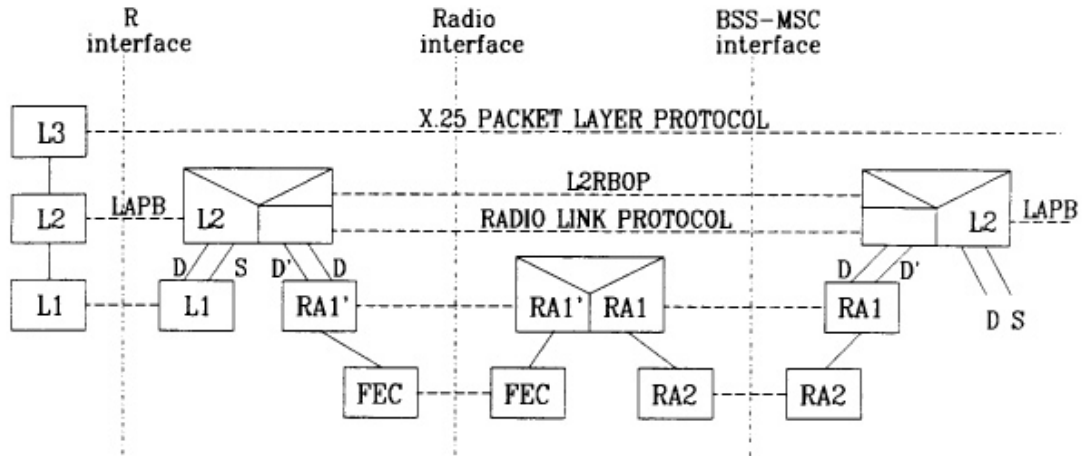

Figure 7: X.25 access at R-interface

5.1.2 S-interface

Figure 8 describes the protocol model and rate adaptation functions applied, when the method indicated in CCITT X.30 is used (see Model 4a of Figure 6/GSM 03.10).

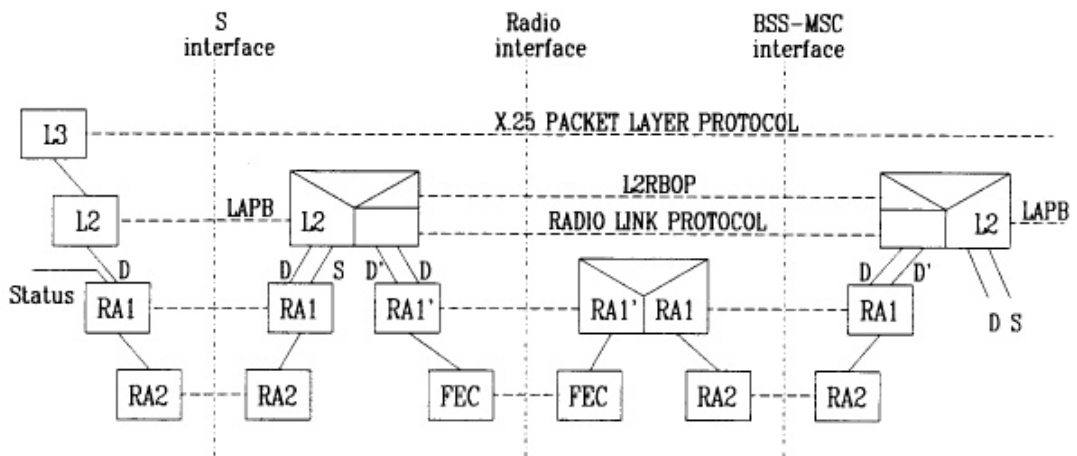

Figure 8: X.25 access at S-interface

Figure 9 describes the protocol model and rate adaptation functions applied, when the HDLC interframe flag stuffing shown in the recommendation CCITT X.31 is used (see Model 4c of Figure 6/GSM 03.10).

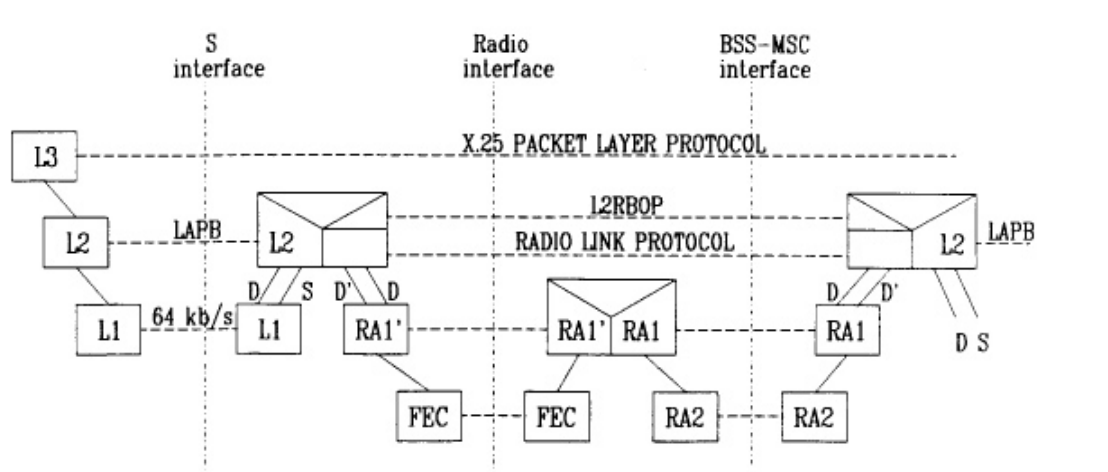

Figure 9: X.25 access at S-interface using Flag Stuffing

5.2 Signalling Mapping

5.2.1 Interchange circuit signalling mapping

The interchange circuit signalling mapping is identical to the transparent case described in section 4.2.

5.2.2 Call establishment signalling mapping

The physical interfaces are mentioned in section 4.3.4 and the signalling mapping is described in section 8.

5.3 Flow Control

The passage of flow control information between L2Rs is described in Annex 1.

5.3.1 Conditions requiring flow control towards the network

The L2R function will send immediately a "flow control active" indication in the following circumstances:

- (i) If the receive buffer from the radio side reaches a preset threshold.
- (ii) If local flow control is initiated by the TE2 (see section 5.3.3 a)). On receipt of this flow control indication transmission of data from the receive buffer towards the TE2 is halted.

On removal of the buffer congestion or local flow control the L2R will send a "flow control inactive" indication.

In addition, for the local flow control condition, transmission of data from the receive buffers will be restarted.

5.3.2 Conditional requiring flow control towards TE2

The L2R function will immediately activate local flow control (see section 5.3.3 b)) under the following circumstances:

- (i) The transmit buffer reaches a pre-set threshold.
- (ii) The L2R receives a "flow control active" indication.

On removal of the buffer congestion or receipt of L2R/RLP "flow control inactive" the local flow control will be removed.

5.3.3 Local flow control

Only inband flow control is allowed:

- a) from TE2:
RNR is sent to indicate flow control active. RR is sent to indicate flow control inactive. Where RR/RNR is utilized then the TAF will generate flow control active/inactive immediately.
- b) From TAF: As from TE2.
Where this method is used, the L2R will pass the RNR/RR frames to the TE2.

5.4 Buffers

5.4.1 TX buffers

Data received from the TE2 shall be buffered such that if the MT is unable to transfer the data over the radio path then data is not lost.

The buffer shall be capable of holding n_1 bytes. When the buffer is half full, TE2 shall be flow controlled as per section 5.3.2. The value for n_1 is 16-32 kbits.

5.4.2 RX buffers

Data for transfer to the TE2 shall be buffered such that if the TE2 is unable to accept data then data transferred from the MT is not lost.

The buffer size should be n_2 bytes. The value for n_2 is 16-32 kbits.

When the buffer becomes half full, the L2R will send a "flow control active" indication.

6 V- and S-series interface procedures to 04.08 mapping

Interface procedures not directly mappable to GSM 04.08 (ie. V.25bis VAL/INV) are not considered. Mobile management procedures of GSM 04.08 are not considered applicable.

Mapping of other call establishment or clearing messages to the S interface e.g. "Call proceeding", etc. have not been included. It is assumed these will be able to be mapped directly and are of no relevance to the V.25bis or manual interface.

For Alternate speech/data and Speech followed by data digital services it will be necessary for the TAF to generate a "Modify" message for transmission, this shall be generated manually derived from MMI. This shall be according to the defined procedure in GSM 04.08.

6.1 Mobile Originated calls

a) SETUP

| Element | Derived from | | |
|--------------------|--|------------------|--|
| | MMI | V.25 bis message | S interface message |
| Called Address | Keypad | CRN/CRI/CRS | Setup |
| Called Sub Address | Keypad | CRI | Setup |
| HLC | Derived from internal settings or MMI information. | | Setup |
| LLC | Same as HLC | | Setup |
| BC | Same as HLC GSM 07.01 gives allowed values | | Setup (with additional information from MMI oriented settings) |

b) RELEASE COMPLETE

| Element | Derived from | | |
|---------|--------------------|------------------|---------------------|
| | MMI | V.25 bis message | S interface message |
| Cause | Display (optional) | CFI | Release Complete |

6.2 Mobile Terminated calls

Call establishment is initiated by receipt of Setup at the MS:

a) SETUP

| Element | Mapped on to | | |
|--------------------|--------------------|------------------|---|
| | MMI | V.25 bis message | S interface message |
| Called Address | Display (optional) | INC | Setup |
| Called Sub Address | Display (optional) | Not applicable | Setup |
| HLC | Display (optional) | Not applicable | Setup |
| LLC | Display (optional) | Not applicable | Setup |
| BC | Display (optional) | Not applicable | Setup (with PLMN specific elements removed) |

b) CALL CONFIRM

Information for the BC element in the call confirm is derived from e.g. MMI or by internal settings.

c) CONNECT

Connect is sent in response to connect from the S-interface, CIC from V.25bis or from MMI.

7 X.21 interface procedures to 04.08 mapping

7.1 X.21 procedures mapping

The X.21 procedures mapping is shown in figures 10 and 11. The Bearer Capability Elements required on Dm channel are shown in GSM 07.01 Annex 2.

Note: DTE corresponds to TE2 and DCE corresponds to MT2 in the signal names of X.21 interface.

7.1.1 Mobile originated call (see figure 10)

Call Request of TE2 to Dm channel SET-UP:

At R interface: In Ready state both TE2 and MT transmit (1,OFF). When the calling TE2 indicates Call Request (0,ON), the MT transmits Proceed to Select (+,OFF). Then the TE2 sends the Selection signals (IA5,ON) and End of Selection (+,ON) and enters the state DTE Waiting (1,ON). The MT shall transmit DCE Waiting (SYN,OFF).

At MS-MSC interface: By receiving Call Request at R-interface, the MT shall start mobile originated call establishment (CHANNEL REQUEST message etc.). When the MT has received Selection signals and End of Selection from TE2, it shall send SET-UP, when possible.

CALL PROCEED:

After the traffic channel assignment is complete, the MT shall start sending (1,OFF) within the 40 bit frames (see sections 4.1.3 and 4.2.2) via the Bm (Lm) channel.

Dm channel ALERT to Call Progress to TE2:

This is applicable only to manually answered calls.

When the MT receives ALERT from Dm channel, it shall transmit Call Progress signals (IA5,OFF) to TE2 and then enter the state DCE Waiting (SYN,OFF).

Dm channel CONN to Ready For Data to TE2:

When the MT receives CONN from Dm channel, it shall respond with CONN ACK message and it may send DCE Provided Information to the calling TE2. The MT transmits then Connection in Progress (1,OFF) to TE2.

When the MT receives a frame with all data bits set to ONE, it performs the switch-through of data and control lines to TE2.

7.1.2 Mobile terminated call (see figure 10)

Dm channel SET-UP to Incoming Call to TE2:

When the TE2 is in Ready state and the MT receives SET-UP via Dm channel, the MT shall respond with ALERT in case of manual answering. Via R interface the MT transmits Incoming Call (Bell,OFF) to TE2.

Call Accepted of TE2 to Dm channel CONN:

When the MT receives Call Accepted via R interface (1,ON), it shall send CONN message via Dm channel.

Dm channel CONN ACK to Ready For Data to TE2:

When the MT receives CONN ACK from Dm channel, it shall start sending (1,OFF) within the 40 bit frames via the Bm (Lm) channel. Via R interface the MT transmits Connection in Progress (1,OFF) to TE2 after delivering DCE Provided Information if any.

When the MT receives a frame with all data bits set to ONE, it performs the switch-through of data and control lines to TE2.

7.1.3 Mobile termination clearing (see figure 11)

DTE Clear Request (0,OFF) is transmitted via Bm (Lm) channel to the cleared terminal. The MT at the clearing TE2 recognizes the Clear Request, transmits DCE Clear Confirmation (0,OFF) to TE2 and sends DISCONNECT message via Dm channel. When the radio channel is released, the MT shall transmit DCE Ready (1,OFF) and TE2 shall then enter the state DTE Ready (1,OFF).

7.1.4 Distant end terminal clearing

When the MT receives DCE Clear Request via Bm (Lm) channel, it shall transmit DCE Clear Indication (0,OFF) to its TE2 via R interface. After the MT has received DTE Clear Confirmation (0,OFF), it sends DISCONNECT message via Dm channel. When the radio channel is released, the MT shall transmit DCE Ready (1,OFF) and TE2 shall then enter the state DTE Ready (1,OFF).

7.1.5 Network generated clearing (see figure 11)

When the MT has received DISCONNECT message via Dm channel, it shall transmit DCE Clear Indication (0,OFF) to its TE2 via R interface. After the MT has received DTE Clear Confirmation (0,OFF) and the radio channel is released, the MT shall transmit DCE Ready (1,OFF) and TE2 shall then enter the state DTE Ready (1,OFF).

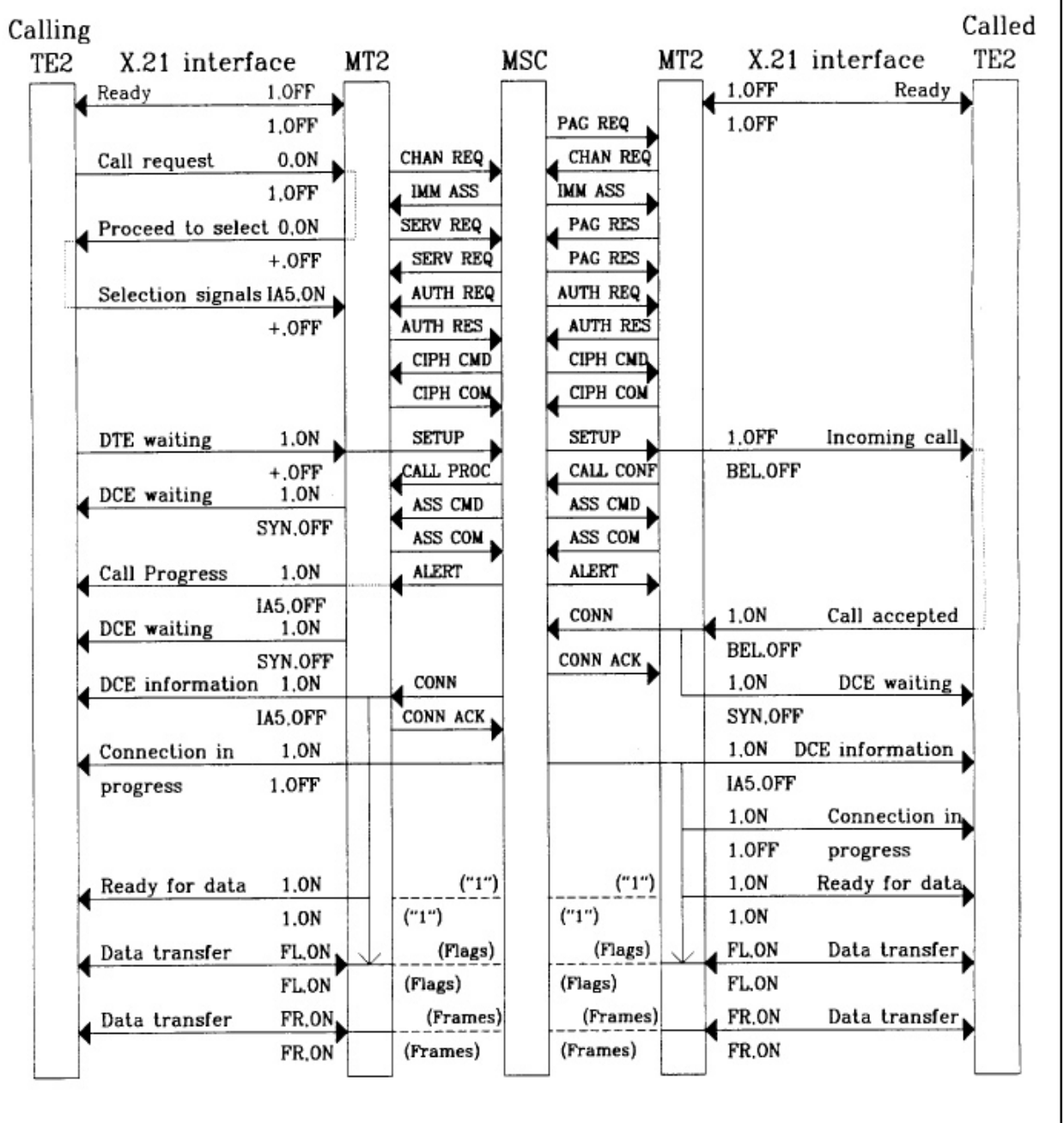

NOTE: In the signal names of X.21 interface DTE corresponds with TE2 and DCE corresponds with MT2.

Figure 10: Example of a calling and a called TE2 (X.21)

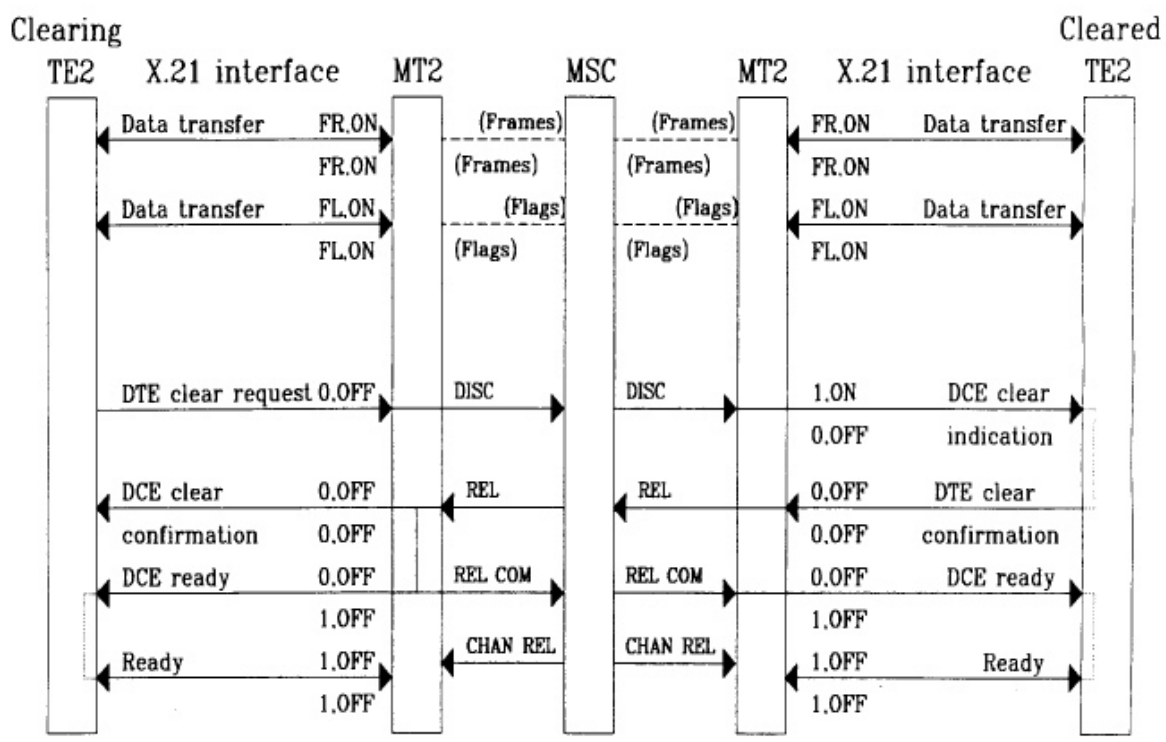

NOTE: In the signal names of X.21 interface DTE corresponds with TE2 and DCE corresponds with MT2.

Figure 11: Example of a clearing and a cleared TE2 (X.21)

7.2 Dm Signalling causes mapping to X.21 call progress signals

The mapping of PLMN Dm channel signalling to X.21 call progress signals and DCE Provided Information is shown in Table 7.

7.3. X.21 FACILITIES MAPPING

The X.21 facilities are shown in Table 8. The mapping of these to PLMN supplementary services is for FS.

Table 7: Mapping of Dm cause fields to X.21 call progress signals

| Item | Dm signalling cause | Code | X.21 call progress signal sign. | Code |
|------|--|------|----------------------------------|------|
| 01 | Unassigned (unallocated) number | 01 | Not obtainable | 43 |
| 02 | No route to destination | 03 | Not obtainable | 43 |
| 03 | Channel unacceptable | 06 | Not obtainable | 43 |
| 04 | Normal call clearing | 16 | ---- | |
| 05 | User busy | 17 | Number busy | 21 |
| 06 | No user responding | 18 | No connection | 20 |
| 07 | User alerting, no answer | 19 | No connection | 20 |
| 08 | Call rejected | 21 | Controlled not ready | 45 |
| 09 | Number changed | 22 | Changed number | 42 |
| 10 | Destination out of order | 27 | Uncontrolled not ready | 46 |
| 11 | Invalid number format (incomplete) | 28 | Selection sign. procedure error | 22 |
| 12 | Facility rejected | 29 | Invalid facility request | 48 |
| 13 | Respon to status enquiry | 30 | ---- | |
| 14 | Normal, unspecified | 31 | ---- | |
| 15 | No circuit/channel available | 34 | No connection | 20 |
| 16 | Network out of order | 38 | Out of order | 44 |
| 17 | Temporary failure | 41 | Out of order | 44 |
| 18 | Switching equipment congestion | 42 | Network congestion | 61 |
| 19 | Access information discarded | 43 | ---- | |
| 20 | Requested circuit/channel not available | 44 | No connection | 20 |
| 21 | Resources unavailable, unspecified | 47 | Network congestion | 61 |
| 22 | Quality of service unavailable | 49 | ---- | |
| 23 | Requested facility not subscribed | 50 | Invalid facility request | 48 |
| 24 | Bearer capability not authorized | 57 | Incompat. user class of service | 52 |
| 25 | Bearer capability not presently available | 58 | Network congestion | 61 |
| 26 | Service or option not available, unspecified | 63 | No connection | 20 |
| 27 | Bearer service not implemented | 65 | Invalid facility request | 48 |
| 28 | Only restricted digital information bearer capability is available | 70 | Invalid facility request | 48 |
| 29 | Service or option not implemented, unspecified | 79 | Invalid facility request | 48 |
| 30 | Invalid call reference value | 81 | Not obtainable | 43 |
| 31 | Incompatible destination | 88 | Not obtainable | 43 |
| 32 | Invalid transit network selection | 91 | Not obtainable | 43 |
| 33 | Invalid message, unspecified | 95 | Selection signal transmis. error | 23 |
| 34 | Mandatory info. element error | 96 | Selection signal procedure error | 22 |
| 35 | Message type non-existent or not implemented | 97 | Selection signal procedure error | 22 |
| 36 | Message not compatible with call state or message type non-existent or not implemented | 98 | Selection signal procedure error | 22 |
| 37 | Information element non-existent or not implemented | 99 | Selection signal procedure error | 22 |
| 38 | Invalid info. element contents | 100 | Selection signal transm. error | 23 |
| 39 | Message not compatible with call state | 101 | Selection signal procedure error | 22 |
| 40 | Recovery on timer expiry | 102 | Not obtainable | 43 |
| 41 | Protocol error, unspecified | 111 | Selection signal procedure error | 22 |
| 42 | Interworking, unspecified | 127 | RPOA out of order | 72 |

Table 8: X.21 facilities

| Facility request code | Facility |
|-----------------------|----------------------------------|
| 1 | Closed user group |
| 45 | DTE inactive registration |
| 45 | DTE inactive cancellation |
| 60 | Multiple address calling |
| 61 | Charging information |
| 62 | Called line identification |
| 63 | Redirection of callactivation |
| 63 | Redirection of callcancellation |
| 63 | Redirection of callstatus |
| 64 | Reverse status |
| 65 | Direct call registration |
| 65 | Direct call cancellation |
| 66 | Abbreviated address registration |
| 66 | Abbreviated address cancellation |

8 Support for packet service

There are two ways of supporting packet services, namely as Basic PacketMode Service and Dedicated PacketMode Service. In the Basic Packet Access case the GSM PLMN provides a connection to the PSPDN port or the PH of other networks, where as in the Dedicated Packet Mode Service case the GSM PLMN provides access to the PSPDN of its own (see GSM 09.06).

8.1 Terminal configurations

The terminal configurations are shown in figure 12. The TE2 can be connected to MT2 or TA via X.21, X.21bis or V-series interface. Table 9 shows various interface types at R reference point.

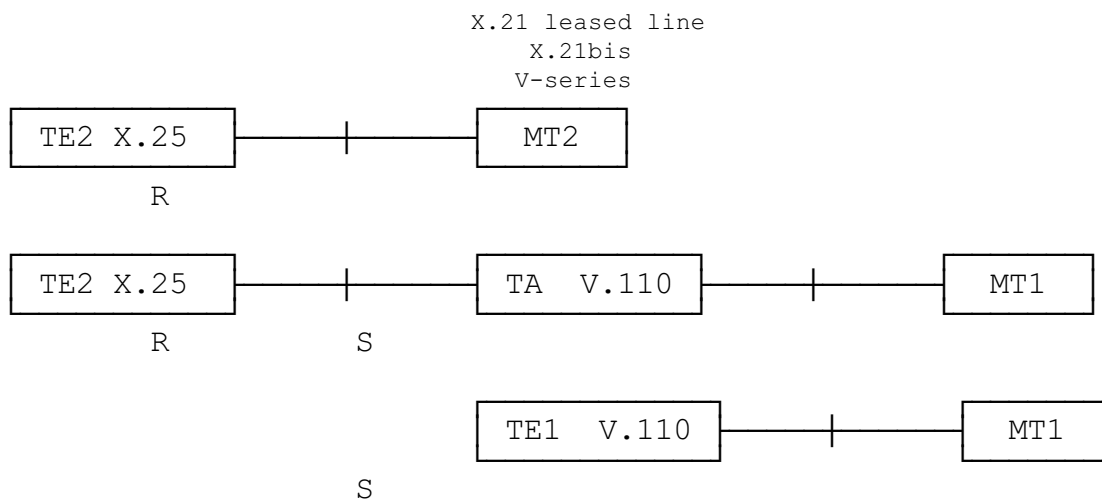

Figure 12: Packet mode terminal configurations

NOTE: For all configurations:

The proper operation of LAPB requires fixing of working parameters, this is detailed in specification GSM 09.06.

Table 9: TE2/MT2 layer 1 specifications and procedures to initiate Bm channel establishment

| Condition | TE2/MT2 Layer 1 specification | | Events at the R reference point | Procedures according to: |
|------------------------------|-------------------------------|---------------------|--|-------------------------------------|
| Hot-line access (Note) | X.25 | X.21 leased circuit | TE2 sets C=ON | CCITT Rec X.25 section 1.1 |
| | | X.21bis | TE2 sets circuit 108=ON | CCITT Rec X.25 section 1.2 |
| | | V-series interface | TE2 sets circuit 108=ON | CCITT Rec X.25 section 1.3 |
| | X.21 circuit-switched | | TE2 signals direct call | CCITT Rec X.21 section 4.4 |
| | X.21bis direct call | | TE2 signals direct call | CCITT Rec X.21bis section 2.3.1 |
| Full circuit-switched access | X.21 addressed call | | TE2 enters call control phase | CCITT Rec X.21 section 4 |
| | X.21bis addressed call | | TE2 performs auto-automatic address call | CCITT Rec X.21bis section 2.3.2 iii |
| | V.25bis addressed call | | TE2 uses address call mode | CCITT Rec V.25 section 4 |

NOTE: In this case the terminal equipment assumes a semipermanent connection. After appropriate event at R reference point the MT2 will establish Bm channel to the PSPDN port or the PHF. MT2 requires the address of the PSPDN port or the PH and the setting of the parameters of the BC/LLC-IEs as described in sections 8.2 and 8.3.

8.2 Support for basic packet access

The GSM PLMN shall support the Basic Packet Mode Service in line with TS 09.06, thus the definitions laid down therein apply accordingly to the subject matter of this section.

For mobile originated call the Call Set-up message contains the E.164 address of the PSPDN port or the PHAU. This address will be provided by TE1 or TA in the case of S interface or by TE2 (R interface). The address must be provided either by MMI or by internal settings of MT2, if the TE2 is an ordinary X.25 terminal connected via "X.21 leased line", "X.21bis" or "V-series" interface.

The required settings of the parameters of the BC/LLC-IE is shown in GSM 07.01. This setting might be performed via the MMI or being based on internal settings within the MT2.

For an incoming call the connection establishment is in line with GSM 09.06, 09.07 and 04.08. In the case of V-series interface (full circuit switched access) the TE2 must support V.25bis Auto Answer procedure.

When the connection between the PSPDN port and the PH, respectively, and the TE is established, the TAF shall take care of mapping Bm channel to/from:

- a) V series or X series interface data circuits
- b) B channel in case of S interface

TE/MT and PSPDN port and the PH, respectively, take care of higher layer protocols, e.g. X.32 identification and X.25 LAPB and PLP.

8.3 Support for dedicated packet access

GSM 09.06 applies in its parts dealing with the Dedicated Packet Mode Service.

In this case the GSM PLMN gives a uniform access to packet services based on the PH-concept of the ISDN for case A, confined to mobile originated calls. The mobile subscriber indicates BC-IE elements as per GSM 07.01. The short code indicates the case of Dedicated Packet Access.

The mapping of data over V, X or S interface to/from Bm channel is identical to the Basic Packet Mode Service case.

The format of the numbering plan used in the X.25 Call Request Packet will be X.121. Numbering plan interworking in case of E.164 address is according to GSM 09.06.

Annex A (normative): L2R Functionality

A.1 Introduction

This annex describes the Layer 2 Relay (L2R) functionality required to support LAPB non-transparently. The general aspects of L2Rs are described in specification GSM 07.01. Figure 1 shows the three sub-functions of the L2R.

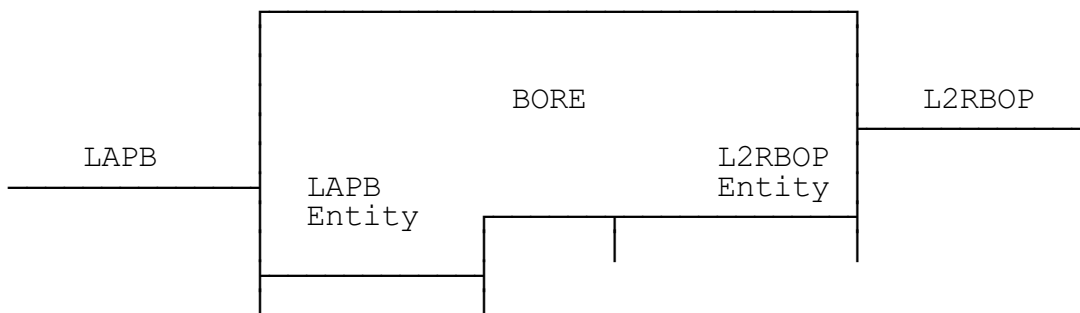

LAPB Link Access Protocol Balanced
 BORE Bit Oriented Relay Entity
 L2RBOP L2R Bit Oriented Protocol

Figure 1: Sub-functions of the L2R

Section 2 describes the L2R Bit Oriented Protocol (L2RBOP) and section 3 describes the use of the L2RBOP to transport LAPB information fields.

A.2 L2RBOP

The LAPB user information fields and interface status changes are transferred between L2Rs using the services of the radio link. The L2RBOP entity segments and reassembles the LAPB user information fields to fit into the fixed length service data units (SDUs) handled by the radio link. I.e. segments of LAPB user information fields and interface status changes are transferred between L2Rs in fixed length n octet Protocol Data Units (PDUs). This corresponds to the RLP fixed length information field. The octets within the L2RBOP-PDU are numbered 0 to n-1, octet 0 is transmitted first. The bits within the octets are numbered 1 to 8, bit 1 is transmitted first.

The L2RBOP also provides facilities for transferring LAPB connection control information between L2Rs. This LAPB connection control information allows concatenated LAPB connections to be established, reset and released.

The L2RBOP PDUs are coded as follows:

- Each octet contains a status octet, 8 bits of user information, control information or fill.
- Octet 0 always contains a status octet.
- Status octets contain 3 status bits and 5 address bits.
- The 3 status bits are used to convey the interface conditions that are conveyed by the S and X bits in CCITT recommendations V.110 and X.30. In the case of V series interfaces the 3 status bits correspond to SA, SB and X bits specified in V.110. In the case of X series interfaces only 2 bits are used and these correspond to S and X bits specified in X.30. The V series SA, SB and X bits use bit positions 8, 7 and 6 respectively in the status octets. The X series S and X bits use bit positions 7 and 6 respectively, in this case bit position 8 is unused.

- LAPB user information is carried in L2RBOP-PDU information octets such that the first LAPB user information bit, in any consecutive group of 8, received or transmitted corresponds to bit position 1 in the octet. The second to bit position 2, etc.
- Information octets are inserted into the L2RBOP-PDU in order of arrival in octets 1 to n-1.
- The address field in the status octets indicates the position of the next status octet within the L2RBOP-PDU. This indicates the number of information octets between status octets. Thus if two status octets are inserted into an L2RBOP-PDU at offsets 1 and m the address field value for the status octet at offset 1 will be defined by m-1-1. The low order bit of the address corresponds to bit 1 of the octet and the high order bit to bit 5.
- Status octets are inserted in the information stream whenever a status change needs to be transmitted.
- Only address values 1 to n-2 (currently expected to be 23) in the address field of status octets are used for addressing purposes. The remaining codes are used to indicate:
 - Last status change, remainder of L2RBOP-PDU is empty. Address field value is 31.
 - Last status change, remainder of L2RBOP-PDU full of information octets. Address field value is 30.
 - End of a LAPB user information field. Address field value is 29. This is used to delimit LAPB user information fields. In this case the 3 status bits do not have their usual meaning. They are used to indicate the number of information bits in the previous information octet. A binary number in the range 0 to 7 is contained in bit positions 8, 7 and 6, bit 6 is the low order bit. The values 1-7 indicate the number of information bits used, value 0 indicates all bits used. If this octet is not on the last position in a L2RBOP-PDU another status octet follows (e.g. an End of LAPB user information field in octet 0 is followed by a status octet in octet 1).
 - Abort a LAPB user information field transfer. The address field value is 28. This is used to abort the transmission of a LAPB user information field after sending one or more segments in L2RBOP-PDUs. If this octet is not on the last position in a L2RBOP-PDU another status octet is following (e.g. an Abort a LAPB user information field transfer in octet 0 is followed by a status octet in octet 1).
 - Address field values 24-27 are reserved.
- When it is necessary to insert a status octet into the information stream when no status change has occurred, e.g. to indicate that the remainder of an L2RBOP-PDU is empty or to indicate end of a LAPB user information field, the current status shall be repeated.
- LAPB connection control information is transferred between L2Rs by use of a connection control PDU. Connection control PDUs consist of an L2RBOP PDU with the status octet in octet 0 containing address field value 0. The coding of the remainder of the L2RBOP connection control PDU is as follows:
 - Octet 1 contains the connection number, always 0 for LAPB. Other values are reserved for future use.
 - Octet 2 contains the connection control information. The connection control information values are 1 for Connect, 2 for Reset, 3 for Disconnect and 4 for loss of LAPB interframe fill. This octet is coded as a binary number with the low order bit corresponding to bit 1.
 - The use of octets 3 to n-1 is reserved.

- LAPB exchange identification frames (XID) are transferred between L2Rs by use of exchange identification PDUs. These PDUs consist of L2RBOP PDUs with the status octet in octet 0 containing address field values 0. The coding of the remainder of the PDU is as follows:
 - Octet 1 contains the connection number, always 0 for LAPB. Other values are reserved for future use.
 - Octet 2 contains the exchange identification indication. The values are 5 for an Exchange Identification Request and 6 for an Exchange Identification Acknowledge. The values 7 to 255 are reserved. This octet is coded as a binary number with the low order bit corresponding to bit 1.
 - The octet 3 contains a normal status octet. The rest of the PDU and of the following PDUs, if any, is used to transfer the XID information and it is treated like normal user data information PDUs as far as the coding is concerned.

A.3 Use of the L2RBOP

The L2R function required to support LAPB non-transparently consists conceptually of the three sub-functions shown in figure 1, i.e. the LAPB entity, the BORE and the L2RBOP entity. These perform the following functions:

- LAPB entity - This terminates the LAPB protocol from the terminal or the network. The service provided by the LAPB entity to the BORE is described in ISO DIS 8886.2 - OSI Data link service definition.
- L2RBOP entity - This uses the services provided by the radio link, see specification GSM 04.22. The service provided by the LAPB entity to the BORE.
- BORE - This concatenates the data link services provided by the use of the L2RBOP and LAPB.

The functions are described in more detail in the following sections.

A.3.1 Radio Link Connection Control

The L2RBOP entity uses the services of the radio link to establish, reset and release the connection to its peer L2RBOP entity. The radio link connection will be established and released as a result of indications from the signalling mechanisms when the supporting circuit switched connection is established.

After an RLP reset or RLP disconnect the L2RBOP entities shall assume that the remote LAPB connection is in disconnected state. No data can therefore be transported between the L2RBOP entities before an exchange of the connection control PDU "Connect" has taken place. All connection control PDUs transferred before the RLP reset are no longer valid and must not be acknowledged. All PDUs (except XID) received by the L2RBOP entities after an RLP reset or disconnect and before a new connection control PDU "Connect" has been received will be discarded by the L2RBOP entity.

A.3.2 Status transfer

The L2RBOP entity transfers interface status information between L2Rs via the status octets in the L2RBOP-PDUs. The meaning of the bits is exactly the same as that defined in CCITT recommendation V.110 and X.30. Status changes are inserted in the L2RBOP-PDU in the position corresponding to the position in the information stream at the DTE/DCE interface that the interface status change occurred.

A.3.3 LAPB connection control

The L2RBOP entity transfers LAPB connection control information between L2Rs via the L2RBOP connection control PDUs. This allows a LAPB connection to be established, reset and released when the remote LAPB connection is established, reset and released or vice versa. L2RBOP connection control PDUs containing connect or reset requests shall be acknowledged by a similarly coded L2RBOP connection control PDU in the reverse direction. Data transfer between L2Rs is not allowed until the connection control acknowledge PDU is received.

In the case of requests crossing they shall each be treated as acknowledgements of the other.

A.3.4 LAPB exchange identification

The L2RBOP entity transfers a LAPB exchange identification request/acknowledge between L2Rs via the L2RBOP exchange identification PDUs. This allows transfer of identification information prior to link establishment and/or during the link (especially with respect to ISO 8885/DADI). A L2RBOP exchange identification request PDU shall be answered by an associated exchange identification acknowledge PDU. In case of crossing of two requests each request shall be answered individually. A LAPB exchange identification request with identification information will be acknowledged by the LAPB entity from L2R only when the acknowledge from the remote LAPB connection is indicated by an exchange identification acknowledge PDU sent by the remote L2RBOP entity.

A.3.5 Data Transfer

The L2RBOP entity assembles and disassembles L2RBOP-PDUs by segmenting and reassembling the LAPB user information fields.

A.3.6 Flow control

Flow control information is transferred between L2Rs in two ways, these are:

- back pressure caused by L2R buffer conditions
- use of the X-bit in the status octet,
 - X = 1 flow control active
 - X = 0 flow control inactive

History

| Document history | |
|------------------|------------------------------|
| April 1996 | Creation of Version 5.0.0 |
| May 1996 | Publication of Version 5.0.0 |
| | |
| | |
| | |