



GSM **T**ELECOMMUNICATION **S**PECIFICATION

GSM 03.41

March 1996

Version 5.1.0

Source: ETSI TC-SMG

Reference: TS/SMG-040341QR

ICS: 33.060.50

Key words: Digital cellular telecommunications system, Global System for Mobile communications (GSM)

GSM

GLOBAL SYSTEM FOR
MOBILE COMMUNICATIONS

Digital cellular telecommunications system (Phase 2+); Technical realization of Short Message Service Cell Broadcast (SMSCB) (GSM 03.41)

ETSI

European Telecommunications Standards Institute

ETSI Secretariat

Postal address: F-06921 Sophia Antipolis CEDEX - FRANCE

Office address: 650 Route des Lucioles - Sophia Antipolis - Valbonne - FRANCE

X.400: c=fr, a=atlas, p=etsi, s=secretariat - **Internet:** secretariat@etsi.fr

Tel.: +33 92 94 42 00 - Fax: +33 93 65 47 16

*

Copyright Notification: No part may be reproduced except as authorized by written permission. The copyright and the foregoing restriction extend to reproduction in all media.

© European Telecommunications Standards Institute 1996. All rights reserved.

Contents

Foreword	5
1 Scope	7
1.1 Normative references	7
1.2 Abbreviations	7
2 General description	8
3 Network Architecture	9
4 CBE Functionality	9
5 CBC Functionality	10
6 BSC Functionality	10
7 BTS Functionality	11
8 MS Functionality	11
9 Protocols and Protocol Architecture	11
9.1 CBC-BSC Primitives	13
9.1.1 Write-Replace Request/Indication	14
9.1.2 Kill-Message Request/Indication	14
9.1.3 Report-Success Response/Confirm	14
9.1.4 Status-CBCH-Query Request/Indication	15
9.1.5 Status-CBCH-Query Response/Confirm	15
9.1.6 Status-Message-Query Request/Indication	15
9.1.7 Status-Message-Query Response/Confirm	15
9.1.8 Report-Failure Response/Confirm	16
9.1.9 RESTART-INDICATION Request/Indication	16
9.1.10 RESET Request/Indication	16
9.1.11 FAILURE-INDICATION Request/Indication	17
9.1.12 SET-DRX Request/Indication	17
9.1.13 SET-DRX-Report Response/Confirm	17
9.2 Parameters	18
9.3 Message Format on BTS-MS Interface	21
9.3.1 General Description	21
9.3.2 Message Content	21
Annex A: Not used	24
Annex B (Informative): Protocols for interconnecting CBC and BSC	25
History	26

Blank page

Foreword

This Global System for Mobile communications Technical Specification (GTS) has been produced by the Special Mobile Group (SMG) Technical Committee (TC) of the European Telecommunications Standards Institute (ETSI).

This GTS defines describes the Cell Broadcast short message service (CBS). It defines the message formats over the Base Station System - Mobile Station (BSS-MS) interface for the Teleservice 23 within the digital cellular telecommunications system (Phase 2/Phase 2+).

This GTS is a TC-SMG approved GSM technical specification version 5, which contains GSM Phase 2+ enhancements/features to the version 4 GSM technical specification. The ETS from which this Phase 2+ GTS has evolved is Phase 2 GSM ETS 300 537 edition 2 (GSM 03.41 version 4.11.0).

GTS are produced by TC-SMG to enable the GSM Phase 2 + specifications to become publicly available, prior to submission for the formal ETSI standards approval procedure to become European Telecommunications Standards (ETS). This ensures the earliest possible access to GSM Phase 2 + specifications for all Manufacturers, Network operators and implementors of the Global System for Mobile communications.

The contents of this GTS are subject to continuing work within TC-SMG and may change following formal TC-SMG approval. Should TC-SMG modify the contents of this GTS it will then be republished by ETSI with an identifying change of release date and an increase in version number as follows:

Version 5.x.y

where:

- y the third digit is incremented when editorial only changes have been incorporated in the specification;

- x the second digit is incremented for all other types of changes, i.e. technical enhancements, corrections, updates, etc.

Reference is made within this TS to GSM-TSs (note).

NOTE: TC-SMG has produced documents which give the technical specifications for the implementation of the digital cellular telecommunications system. Historically, these documents have been identified as GSM Technical Specifications (GSM-TSs). These TSs may have subsequently become I-ETs (Phase 1), or ETs/ETSI Technical Reports (ETRs) (Phase 2). TC-SMG has also produced ETSI GSM TSs which give the technical specifications for the implementation of Phase 2+ enhancements of the digital cellular telecommunications system. These version 5.x.x GSM Technical Specifications may be referred to as GTs.

Blank page

1 Scope

This specification describes the Cell Broadcast short message service (CBS). It defines the message formats over the BSS-MS interface for the Teleservice 23 as specified in GSM 02.03.

1.1 Normative references

This GTS incorporates by dated and undated reference, provisions from other publications. These normative references are cited at the appropriate places in the text and the publications are listed hereafter. For dated references, subsequent amendments to or revisions of any of these publications apply to this GTS only when incorporated in it by amendment or revision. For undated references, the latest edition of the publication referred to applies.

- [1] GSM 01.04 (ETR 100): "Digital cellular telecommunication system (Phase 2); Abbreviations and acronyms".
- [2] GSM 02.03 (ETS 300 502): "Digital cellular telecommunication system (Phase 2); Teleservices supported by a GSM Public Land Mobile Network (PLMN)".
- [3] GSM 03.38 (ETS 300 628): "Digital cellular telecommunication system (Phase 2); Alphabets and language-specific information".
- [4] GSM 03.40 (ETS 300 536): "Digital cellular telecommunication system (Phase 2); Technical realization of the Short Message Service (SMS) Point to Point (PP)".
- [5] GSM 03.47 (ETR 106): "Digital cellular telecommunication system (Phase 2); Example protocol stacks for interconnecting Service Centre(s) (SC) and Mobile-services Switching Centre(s) (MSC)".
- [6] GSM 03.49 (ETR 107): "Digital cellular telecommunication system (Phase 2); Example protocol stacks for interconnecting Cell Broadcast Centre (CBC) and Base Station Controller (BSC)".
- [7] GSM 04.12 (ETS 300 560): "Digital cellular telecommunication system (Phase 2); Short Message Service Cell Broadcast (SMS-CB) support on the mobile radio interface".
- [8] GSM 05.02 (ETS 300 574): "Digital cellular telecommunication system (Phase 2); Multiplexing and multiple access on the radio path".
- [9] GSM 07.05 (ETS 300 585): "Digital cellular telecommunication system (Phase 2); Use of Data Terminal Equipment - Data Circuit terminating Equipment (DTE - DCE) interface for Short Message Service (SMS) and Cell Broadcast Service (CBS)".
- [10] GSM 08.52 (ETS 300 593): "Digital cellular telecommunication system (Phase 2); Base Station Controller - Base Transceiver Station (BSC - BTS) interface Interface principles".
- [11] GSM 08.58 (ETS 300 596): "Digital cellular telecommunication system (Phase 2); Base Station Controller - Base Transceiver Station (BSC - BTS) interface Layer 3 specification".
- [12] CCITT Recommendation X.210: "Open systems interconnection layer service definition conventions".

1.2 Abbreviations

Abbreviations used in this specification are listed in GSM 01.04.

2 General description

The CBS service is analogous to the Teletex service offered on television, in that like Teletex, it permits a number of unacknowledged general messages to be broadcast to all receivers within a particular region. CBS messages are broadcast to defined geographical areas known as cell broadcast areas. These areas may comprise of one or more cells, or may comprise the entire PLMN. Individual CBS messages will be assigned their own geographical coverage areas by mutual agreement between the information provider and the PLMN operator. CBS messages may originate from a number of Cell Broadcast Entities (CBEs), which are connected to the Cell Broadcast Centre. CBS messages are then sent from the CBC to the BTSs, in accordance with the CBS's coverage requirements.

The CBS message comprises of 82 octets, which, using the default character set, equates to 93 characters. Up to 15 of these messages (pages) may be concatenated to form a macromessage. Each page of such macromessages will have the same message identifier (indicating the source of the message), and the same serial number. Using this information, the MS is able to identify and ignore re-broadcasts of already received messages.

CBS messages are broadcast cyclically by the BTS at a frequency and for a duration specified by the information provider. The frequency at which messages are repeatedly transmitted will be dependent on the information that they contain; for example, it is likely that dynamic information such as road traffic information, will require more frequent transmission than weather information. The repetition rate will also be affected by the desire for messages to be received by high speed mobiles which rapidly traverse cells. All suitably equipped mobiles within the catchment area of the transmitting BTS will be able to receive the broadcast messages, provided that they are switched on and in the idle state.

To permit mobiles to selectively display only those messages required by the MS user, CBS messages are assigned a message class which categorises the type of information that they contain and the language in which the message has been compiled. Through the use of appropriate MMI, the user is then able to ignore message types that he does not wish to receive, e.g. advertising information or messages in an unfamiliar language.

3 Network Architecture

The basic network structure of CBS is depicted by Figure 1.

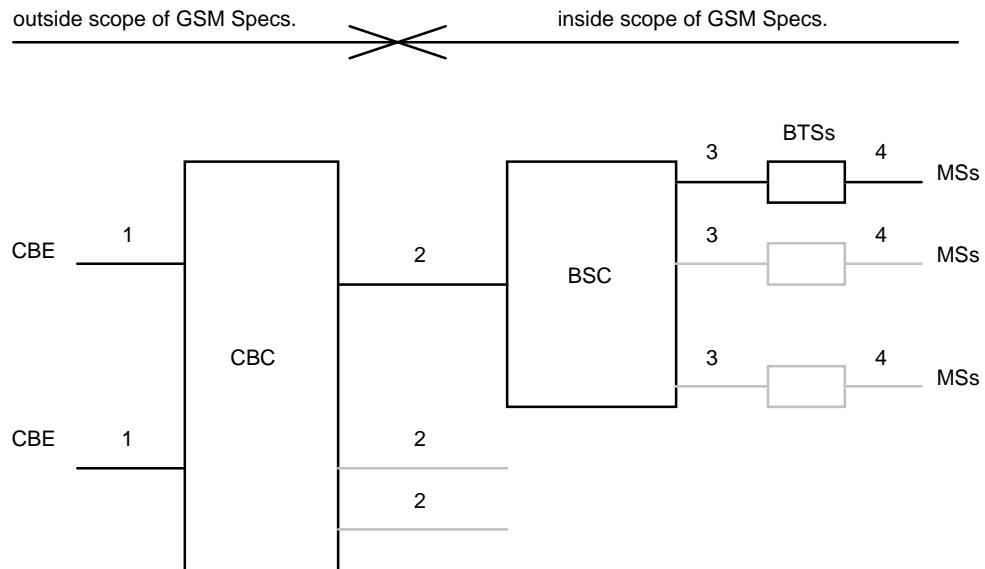

Figure 1

- message transfer on link 1 is outside the scope of GSM Specifications
- message transfer on link 2 is described in Section 9.1
- message transfer on link 3 is described in GSM 08.58
- message transfer on link 4 is described in GSM 04.12 and the timing of messages transferred on link 4 is described in GSM 05.02

4 CBE Functionality

The functionality of the CBE is outside of the scope of GSM Specifications; however it is assumed that the CBE is responsible for all aspects of formatting CBS, including the splitting of a CBS message into a number of pages.

5 CBC Functionality

As the CBC (and any originating point for cell broadcast short messages) is regarded as a node outside the PLMN, only the requirements placed upon the CBC by CBS functionality are specified by this specification.

The CBC may be connected to several BSCs. The CBC may be connected to several CBEs. The CBC shall be responsible for the management of cell broadcast short messages including

- allocation of serial numbers
- modifying or deleting messages held by the BSC
- initiating broadcast by sending fixed length cell broadcast short messages to a BSC for each language provided by the cell, and where necessary padding the message with the appropriate character to a length of 82 octets
- determining the set of cells/BTSs to which a message should be broadcast, and indicating within the Serial Number the geographical scope of each message
- determining the time at which a message should commence being broadcast
- determining the time at which a message should cease being broadcast and subsequently instructing each BSC to cease broadcast of the message
- determining the rate at which broadcast of the message should be repeated

6 BSC Functionality

The BSC shall interface to only one CBC. A BSC may interface to several BTSs as indicated by GSM 08.52. The BSC shall be responsible for:

- interpretation of commands from the CBC
- storage of cell broadcast messages
- scheduling of cell broadcast messages on the CBCH
- providing an indication to the CBC when the desired repetition rate cannot be achieved
- providing to the CBC acknowledgement of successful execution of commands received from the CBC
- reporting to the CBC failure when a command received from the CBC is not understood or cannot be executed
- routing cell broadcast messages to the appropriate BTSs
- transferring CBS information to each appropriate BTS via a sequence of 4 SMS BROADCAST REQUEST messages or 1 SMS BROADCAST COMMAND message (see GSM 08.58).
- optionally generating Schedule Messages, indicating the intended schedule of transmissions (see GSM 04.12)
- optionally receiving CBCH Load Indication messages and reacting by broadcasting a burst of scheduled SMSCB messages or by suspending the broadcast for a period indicated by BTS (see GSM 08.58)

7 BTS Functionality

The BTS is responsible for conveying CBS information received via SMS BROADCAST REQUEST or SMS BROADCAST COMMAND messages over the radio path to the MS.

- optionally generating CBCH Load Indication messages, indicating an underflow or overflow situation on the CBCH (see GSM 08.58).

8 MS Functionality

The MS is responsible for recombination of the blocks received via the radio path to reconstitute the cell broadcast short message. The precise method of display of cell broadcast short messages is outside the scope of GSM Specifications, however it is assumed that an MS will

- discard sequences transferred via the radio path (see GSM 04.12) which do not consist of consecutive blocks
- have the ability to discard CBS information which is not in a suitable data coding scheme
- have the ability to discard a message which has a message identifier indicating that it is of subject matter which is not of interest to the MS
- have the ability to ignore repeat broadcasts of messages already received (message has not changed since it was last broadcast i.e. sequence number has not changed within the message's indicated geographical area)
- have the ability to transfer a message via the R interface when the R interface is supported
- optionally enter SMSCB DRX mode based upon received Schedule Messages (see GSM 04.12)
- optionally skip reception of the remaining block(s) of a cell broadcast message which do(es) not contain cell broadcast information (see GSM 04.12)

9 Protocols and Protocol Architecture

Commands interpreted by the BSC will result in a sequence of 4 SMS BROADCAST REQUEST messages or 1 SMS BROADCAST COMMAND message being sent to a BTS, which in turn result in a sequence of 4 messages being transferred via the BTS-MS interface (see GSM 04.12).

With the SMS BROADCAST REQUEST mode of operation, the 88 octet fixed length CBS page which is specified in Section 9.3 is split into four 22 octet blocks which are carried in SMS BROADCAST REQUEST messages as follows:

octets 1-22 are transferred in the 1st SMS BROADCAST REQUEST
with a sequence number (see GSM 04.12) indicating first block

octets 23-44 are transferred in the 2nd SMS BROADCAST REQUEST
with a sequence number (see GSM 04.12) indicating second block

octets 45-66 are transferred in the 3rd SMS BROADCAST REQUEST
with a sequence number (see GSM 04.12) indicating third block

octets 67-88 are transferred in the 4th SMS BROADCAST REQUEST
with a sequence number (see GSM 04.12) indicating fourth block.

Figure 2 illustrates the protocol architecture and the scope of the various GSM Specifications for the SMS BROADCAST REQUEST mode of operation.

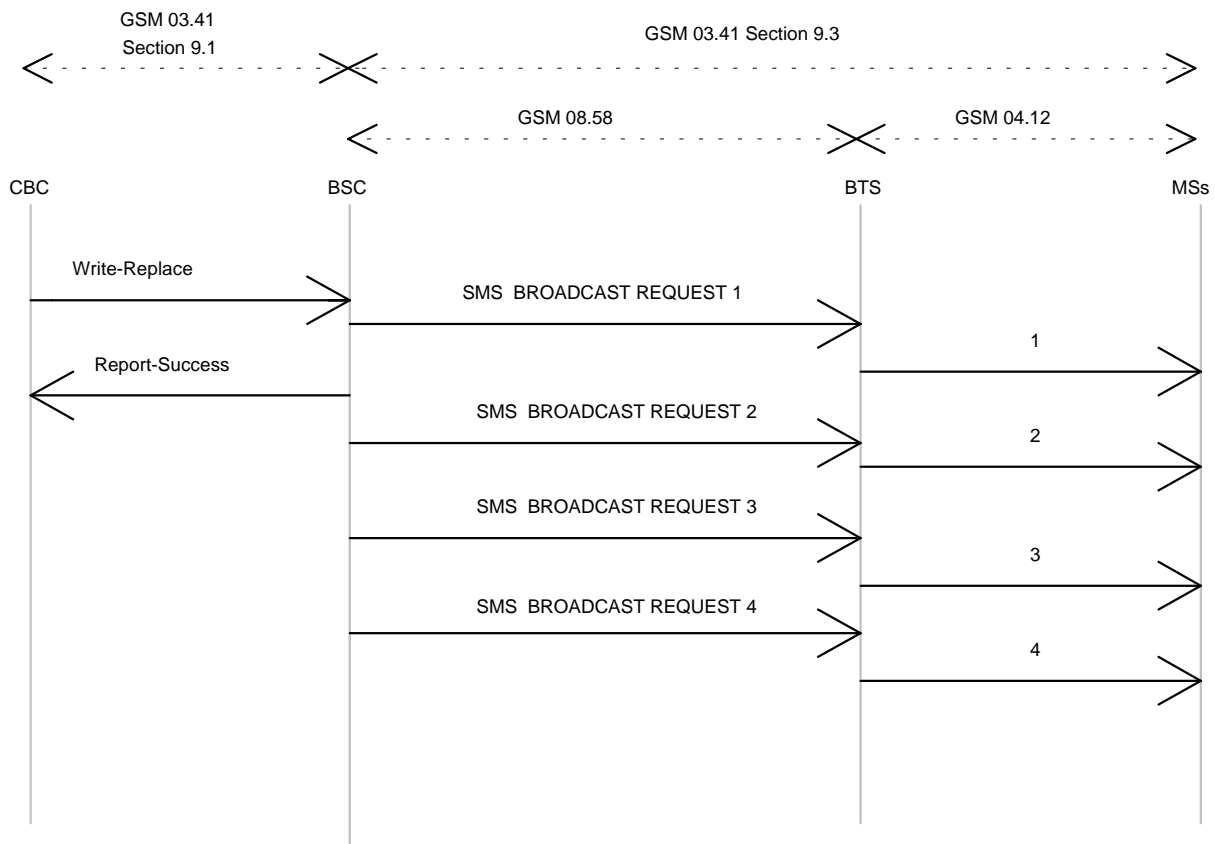

Figure 2

With the SMS BROADCAST COMMAND mode of operation, the BSC sends to the BTS in one single message the 88 octet fixed length CBS page. The BTS then splits the page into four 22 octet blocks, adds the sequence number (see GSM 04.12) and transmits the four resulting blocks on the air.

Figure 3 illustrates the protocol architecture and the scope of the various GSM Specifications for the SMS BROADCAST COMMAND mode of operation.

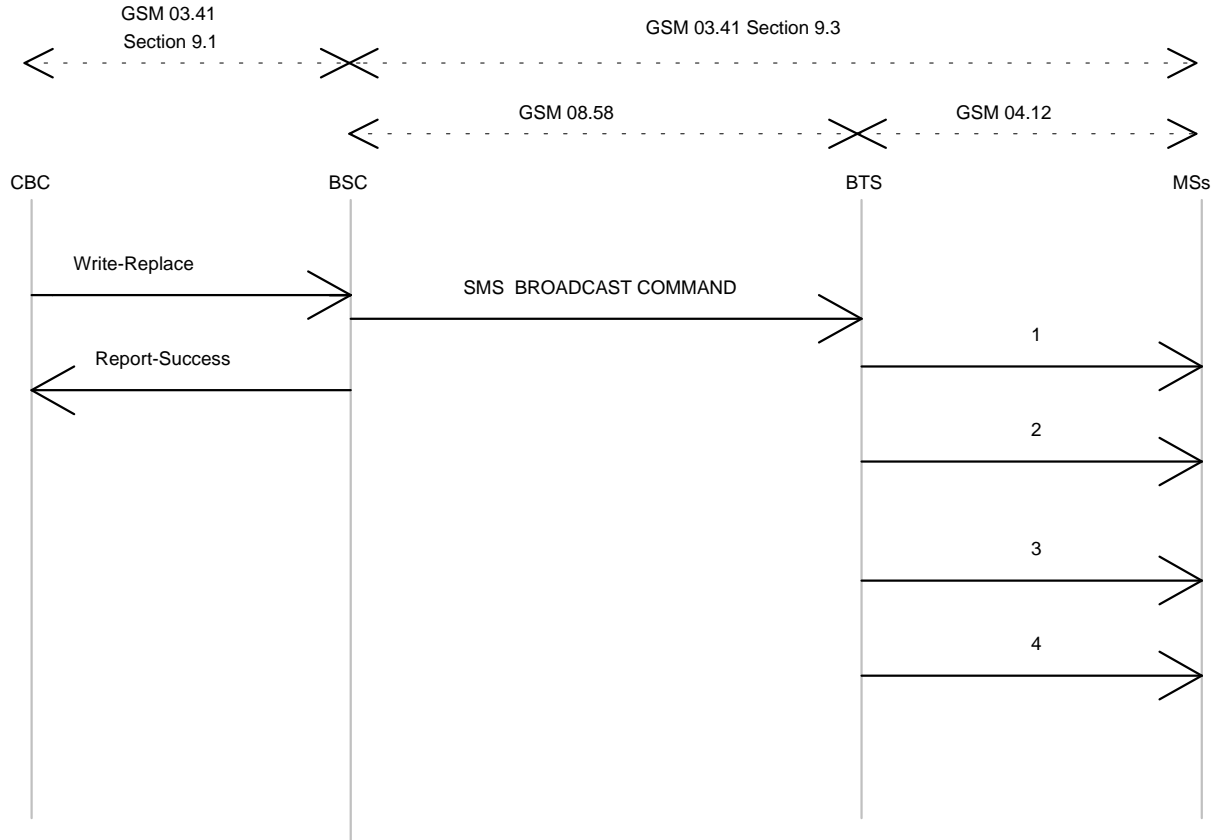

Figure 3

9.1 CBC-BSC Primitives

The term primitive is used to indicate "an abstract, implementation independent interaction between a service user and a service provider" (see CCITT X.210). For the CBC-BSC interface, the service provider would be the protocol interconnecting CBC and BSC. A Primitive may therefore be viewed as an abstract, implementation independent request/indication or response/confirm interaction between the service user (CBC or BSC) and the service provider (protocol). A set of primitives for use between the CBC and BSC is specified appropriate to the functionality assigned to the CBC and BSC in Sections 5 and 6. No mandatory protocol between the CBC and the BSC is specified by GSM, this is a matter of agreement between CBC and PLMN operators. GSM 03.49 (see also Annex B of this specification) provides example protocol stacks using the primitives defined as follows.

NOTE: In the following definitions, M indicates "mandatory parameter" and O indicates "optional parameter".

9.1.1 Write-Replace Request/Indication

parameter

Message-Identifier	M
Old-Serial-Number	O
New-Serial-Number	M
Cell-List	M
Category	O
Repetition-Rate	M
No-of-Broadcasts-Requested	M
Number-of-Pages	M
Data Coding Scheme	M
CBS-Message-Information-Page1	M
CBS-Message-Information-Lenght1	M
CBS-Message-Information-Page2	O
CBS-Message-Information-Lenght2	O
CBS-Message-Information-Page3	O
CBS-Message-Information-Lenght3	O
CBS-Message-Information-Page4	O
CBS-Message-Information-Lenght4	O
CBS-Message-Information-Page5	O
CBS-Message-Information-Lenght5	O
etc.	O
etc.	O

This primitive is sent by the CBC to the BSC. The CBC will use this primitive to either cause a new message to be broadcast or to change a message currently being broadcast.

If no old serial number is present then the primitive will be interpreted by the BSC as an instruction to broadcast a new message. If an old serial number is present, then the primitive will cause all information currently associated with the combination of message identifier and serial number to be deleted from the BSC and be replaced by information conveyed in the primitive.

If no category is present, the default category is interpreted by the BSC, see the parameter section.

Note: in the case of multipage messages, the individual pages are considered as independent by the BSC scheduling algorithm.

9.1.2 Kill-Message Request/Indication

parameter

Message-Identifier	M
Old-serial-Number	M
Cell-List	M

This primitive is sent by the CBC to the BSC. The CBC will use this primitive to kill the message indicated by the combination of message identifier and serial number, i.e. the primitive will halt broadcast of the message and remove any knowledge of the message from the BSC.

9.1.3 Report-Success Response/Confirm

parameter

Message-Identifier	M
Serial Number	M
No-of-Broadcasts-Completed	M
Failure-List	O

This primitive will be sent by the BSC to the CBC in response to Write-Replace-Message and Kill-Message primitives.

In the case of a Write-Replace-Message the No-of-Broadcasts-Completed of the replaced message is reported to the CBC.

The Failure-List will contain those cells which were present in the related Write-Replace or Kill message and which failed the requested operation.

9.1.4 Status-CBCH-Query Request/Indication

parameter

Cell-List	M
-----------	---

This primitive is sent by the CBC to the BSC in order to obtain the current loading of the CBCH of particular cells.

9.1.5 Status-CBCH-Query Response/Confirm

parameter

Cell-List	M
CBCH-Loading-List	M
Failure-List	O

This primitive will be sent by the BSC in response to the Status-CBCH-Query Request/Indication primitive.

The CBCH-Loading-List will contain only cells which were present in the Request message and for which the loading is available. Each entry in the CBCH-Loading-List will exist if and only if there is a corresponding entry in the Cell-List. The Failure-List will contain the remainder of the cell which were present in the Request message.

9.1.6 Status-Message-Query Request/Indication

parameter

Message-Identifier	M
Old-Serial-Number	M
Cell-List	M

This primitive is sent by the CBC to the BSC in order to obtain the current status of a message.

9.1.7 Status-Message-Query Response/Confirm

parameter

Message-Identifier	M
Old-Serial-Number	M
Cell-List	M
No-of-Broadcasts-Completed-List	M
Failure-List	O

This primitive will be sent by the BSC to the CBC in response to a Status-Message-Query Request/Indication primitive.

The No-of-Broadcasts-Completed-List will contain only cells which were present in the Request message and for which the number of broadcasts is available. Each entry in the No-of-Broadcasts-Completed-List will exist if and only if there is a corresponding entry in the Cell-List. The Failure-List will contain the remainder of the cells which were present in the Request message.

9.1.8 Report-Failure Response/Confirm

parameter

Cause	M
Diagnostic	O
Message-Identifier	O
Serial Number	O

This primitive is sent by the BSC to the CBC in response to any primitive which is not understood (e.g. invalid parameter or parameter value) or which cannot be executed due to existing CBCH loadings.

9.1.9 RESTART-INDICATION Request/Indication

parameter

Cell-List	M
Recovery-Indication	O

The RESTART-INDICATION Request is used by the BSC to indicate to the CBC a CB related restart situation in one or more of its cells.

Any referenced cell are again in CB-operational state (have resumed CB operation). However, they are idle, waiting to be loaded with new CB messages from the CBC.

The CBC upon receiving a RESTART INDICATION indication, marks the cell as operational again. It will usually generate WRITE-REPLACE requests for this cell, according to the actual CB message loading at the moment of the restart.

Please note, that a RESTART INDICATION indication may be triggered from the CBC by a RESET Request. This allows to recover from situations, where a PDU occasionally may be lost.

9.1.10 RESET Request/Indication

parameter

Cell-List	M
-----------	---

The RESET Request is used by the CBC to force one or more cells (BTSs) of one BSC into CB-idle state.

The RESET Request may also be used by the CBC to ask for the CB operational state of cells earlier indicated to have failed (polling CB operational state).

If a base station controller (BSC) receives a RESET Indication, the indicated cells enter idle state (same state as after "power on"). All CB related information concerning earlier CB messages in a referenced cell is lost.

The BSC acknowledges the RESET Indication for each cell by an RESTART- or, if not adequate, by a FAILURE-INDICATION request.

Of course, several responses may be combined using a cell list in the RESTART or FAILURE INDICATION.

9.1.11 FAILURE-INDICATION Request/Indication

parameter

Cell-List	M
-----------	---

The FAILURE-INDICATION Request is used by the BSC to indicate to the CBC a CB related problem situation in one or more of its cells.

Any referenced cell enters CB-not-operational state. It has lost all CB messages related information. It remains in not-operational state until a RESTART-INDICATION request (see 9.1.9) indicates normal CB operation (again).

The CBC upon receiving a FAILURE indication, marks this cell as failed. It will generally not generate further WRITE-REPLACE requests for this cell, up to the point, when the CBC is informed by a RESTART indication, that the cell has resumed CB operation.

Please note, that a RESTART Indication may be triggered by a RESET Request. This allows to recover from situations, where a PDU occasionally may be lost.

9.1.12 SET-DRX Request/Indication

parameter

Cell-List	M
Schedule-Period	O
Reserved-Slots	O

The SET-DRX Request is used by the CBC to set DRX specific parameters i.e. the schedule period and the number of slots reserved for high priority messages, see GSM 04.12.

At least one of the Schedule-Period or Reserved-Slots parameters must be present in the primitive. If this primitive is not supported, the BSC may use default values.

If a base station controller (BSC) receives a SET-DRX Indication, the new DRX parameters will be taken into account starting from the next schedule period in each cell, see GSM 04.12.

9.1.13 SET-DRX-Report Response/Confirm

parameter

Cell-List	O
Failure-List	O

This primitive will be sent by the BSC to the CBC in response to a SET-DRX Request/Indication primitive.

The Failure-List will contain those cells which were present in the Request message and which failed the requested operation.

9.2 Parameters

Message-Identifier

- identifies source/type of message.

Old-Serial-Number

- This enables a particular existing message, from the source indicated by the message identifier, to be identified.

New-Serial-Number

- This enables message change to be indicated since it is altered every time the message is changed. The serial number identifies a particular message, which may be several pages in length, from the source indicated by the message identifier.

Number-of-Pages

- enables the number of pages in the message to be indicated.

Cell-List

- This identifies the cells to which the primitives apply. The cell-list shall contain the following information, as described in 08.08, section 3.2.2.27.

cell identification discriminator
cell identity 1
..
cell identity N

Category

- This indicates the category of the message:
 - 0 High Priority: to be broadcast at the earliest opportunity in the slots left free by messages of category 2, then according to the associated repetition rate.
 - 1 Background: to be broadcast in the slots left free by messages of category 0 and 2, possibly shared with unscheduled schedule messages, see GSM 04.12. The repetition rate defines the minimum broadcast requirement.
 - 2 Normal: to be broadcast according to the associated repetition rate.

If the category is omitted, the default category implied is "Normal" message.

Repetition-Rate

- This indicates the frequency at which broadcast of the message should be repeated. The maximum frequency with which a message may be broadcast over the air interface is one 8 x 51 multiframe sequence which corresponds to a period of approximately 1.883 seconds. The value of 'Repetition-Rate' shall be in the range 1 to 1024 where each unit will represent one 8 x 51 multiframe sequence. In the event of a conflict where the BSS has more than one message to send at the same time, the BSC shall decide the order of such messages as an implementation matter.

No-of-Broadcasts-Requested

- This specifies the number of times the message is to be broadcast. The parameter may take any value up to 2880 (this maximum allows the message to be broadcast every 30 seconds for 24 hours). If the parameter is set to 0 then the message will be broadcast indefinitely (i.e. until the BSC receives an appropriate Kill-Message Request/Indication primitive).

No-of-Broadcasts-Completed-List

- This parameter is a list indicating the number of times that the message (i.e. all pages of the message) has been sent to each Cell in the Cell-List for broadcast over the air interface.

Cell-Identity

- identity of cell.

Schedule-Period

- indicates the DRX schedule period length, see GSM 04.12.
It is coded as follows:
0 no DRX
1 to 48 length of the schedule period

Reserved-Slots

- indicates the number of slots reserved in a DRX schedule period for high priority messages, see GSM 04.12
The spacing of the reserved slots is implementation dependent.

Failure-List

- This identifies the list of cells for which the BSC could not complete the request. The failure cause for each cell is indicated.

CBCH-Loading-List

- A list of the predicted short term load of each cell on the list expressed in a percentage. The calculation of this percentage is an implementation matter.

Cause

- indicates reason why the BSC was not able to interpret or execute the received primitive. The causes are given in Table 1

Table 1

Cause	Reason
Parameter-not-recognised	Sent when the recipient (CBC or BSC) was unable to act upon the primitive received due to an unrecognised parameter. A primitive should not be rejected only because a parameter is not recognised as this would prevent extensions to the service
parameter-value-invalid	Sent when a failure occurred due to the value of a parameter being invalid, e.g. out of range, or in Write-Replace, the parameter "no of pages" does not equal the number of pages received
valid-CBS-message-not-identified	Sent when the BSC does not recognise the CBS message serial number
cell-identity-not-valid	Sent when the BSC does not recognise a cell Identity
unrecognised-message	Sent when the recipient entity did not recognise the protocol message identifier
missing-mandatory-element	Sent when a mandatory element is missing from the primitive
bss-capacity-exceeded	Sent when a write-replace fails because the BSC cannot meet the requested repetition rate
cell-memory-exceeded	Sent when the local cell memory has been exceeded
bss-memory-exceeded	Sent when the BSS is unable to store a message as the BSS memory has been exceeded
cell-broadcast-not-supported	Sent when the CBCH is not configured for a cell
cell-broadcast-not-operational	Sent when the CBCH is not available because of error conditions or due to maintenance activities
incompatible-DRX-parameter	Sent when the DRX parameter(s) cannot be applied.
unknown-error	Sent when none of the above cause values apply

Diagnostic

- provides additional information associated with Cause parameter and may contain parameter which could not be interpreted/executed.

Data Coding Scheme

- identifies alphabet or coding employed for the message characters

CBS-Message-Information-Page n

- this carries 82 octets of CBS information.

CBS-Message-Information-Length n

- gives the number of octets of the CBS-Message-Information-Page n containing cell broadcast information. The remaining octets of the CBS-Message-Information-Page n only contain padding information.

Recovery-Indication

- indicates whether the CBS related data was lost or is still available.

CODE	DISPLAY MODE	GEOGRAPHICAL SCOPE
00	Immediate	Cell wide
01	Normal	PLMN wide
10	Normal	Location Area wide
11	Normal	Cell wide

Immediate = default direct display

Normal = default display under user interaction

NOTE: These display modes are indicative of intended use, without indicating a mandatory requirement or constraining the detailed implementation by mobile manufacturers. The user may be able to select activation of these different modes.

NOTE: Code 00 is intended for use by the network operators for base station IDs.

The update number will differentiate between older and newer versions of the same message, within the indicated geographical area. A new message will have update number 0000; this will increment by 1 for each update. Any update number eight or less higher (modulo 16) than the last received update number will be considered more recent, and shall be treated as a new message, provided the mobile has not been switched off.

- (ii) Message Identifier identifies the source and type of message. A number of messages may originate from the same source and/or be of the same type. These will be distinguished by serial number. The Message Identifier is coded in binary.

The ME shall attempt to receive the CBS messages whose Message Identifiers are in the "search list". This "search list" shall contain the Message Identifiers stored in the EF_{CBMI} and EF_{CBMID} files on the SIM (see TS GSM 11.11) and any Message Identifiers stored in the ME in a "list of CBS messages to be received". If an ME has restricted capabilities with respect to the number of Message Identifiers it can search for, then the Message Identifiers stored in the SIM shall take priority over any stored in the ME.

The use/application of the Message Identifiers is as follows:

0000 - 03E7 (hex) to be allocated by PLMN operator associations. If a Message Identifier from this range is in the "search list", then the ME shall attempt to receive this message.

03E8 - 0FFF (hex) intended for standardisation in future versions of GSM 03.41. These values shall not be transmitted by networks that are compliant to this version of GSM 03.41. If a Message Identifier from this range is in the "search list", then the ME shall attempt to receive this message.

1000 - 10FF (hex) Networks shall only use Message Identifiers from this range for Cell Broadcast Data Download to the SIM (see TS GSM 11.14). If a message Identifier from this range is in the "search list", then the ME shall attempt to receive this message.

Note : This version of GSM 03.41 does not prohibit networks from using Message identifiers in the range 0000 - 03E7 (hex) for Cell Broadcast Data Download to the SIM.

1100 - FFFE (hex) intended for standardisation in future versions of GSM 03.41. These values shall not be transmitted by networks that are compliant to this version of GSM 03.41. If a Message Identifier from this range is in the "search list", then the ME shall attempt to receive this message.

FFFF (hex) Reserved, and should not be used for new services, as this value is used on the SIM to indicate that no Message Identifier is stored in those two octets of the SIM. If this Message Identifier is in the "search list", then the ME shall attempt to receive this message.

In the above list, octet 3 of the Message Identifier is shown first, followed by octet 4. Thus "1234" (hex) represents octet 3 = 0001 0010 and octet 4 = 0011 0100.

Identical messages in different languages may use the same message type and serial number, and may be differentiated by using the data coding scheme to specify the language.

NOTE: Optionally, the user can select the language(s) required by using an MMI, to determine whether a particular message should be read and displayed.

Generally, the MMI for entering these codes in the ME is left to the manufacturers' discretion, however the 1000 lowest codes shall be enterable by their decimal representation i.e.:

Octet 3	Octet 4	
0000 0000	0000 0000	(decimal '000')
0000 0000	0000 0001	(decimal '001')
0000 0000	0000 0010	(decimal '002')
0000 0000	0000 0011	(decimal '003')
⋮	⋮	⋮
⋮	⋮	⋮
0000 0011	1110 0111	(decimal '999')

- (iii) Data Coding Scheme indicates the intended handling of the message at the MS, the alphabet/coding, and the language (when applicable). This is defined in TS GSM 03.38.

When the SIM indicates one or more language preferences, the ME shall, by default, use the language(s) stored in the SIM (in the EF_{LP} file) to set any language filter mechanisms provided by the ME.

- (iv) The page parameter is coded as two 4-bit fields. The first field (bits 0-3) indicates the binary value of the total number of pages in the message and the second field (bits 4-7) indicates binary the page number within that sequence. The coding starts at 0001, with 0000 reserved.

Annex A: Not used

Annex A held information that is now contained in GSM 03.38.

Annex B (Informative): Protocols for interconnecting CBC and BSC

No mandatory protocol between the Cell Broadcast Centre (CBC) and the Base Station Controller (BSC) is specified by GSM; this is a matter of agreement between CBC and PLMN operators.

Some example protocols are provided in GSM 03.49 to assist CBC and PLMN operators. These are based on the following principles, which CBC and PLMN operators are recommended to follow even if they choose not to use one of the examples given in GSM 03.49:

The protocol(s) between CBC and BSC should:

- a) provide the service defined for the CBC-BSC interface (see Section 9).
- b) be based on protocols normally used for communication between switching and/or computer equipment
- c) permit open interconnection - preferably using the OSI stack or equivalent (e.g. CCITT Number 7 Stack).

History

Document history	
October 1995	Creation of Version 5.0.0 (Version 4.11.0 + AR002r1 + AR011r2)
January 1996	Publication of Version 5.0.0
February 1996	Creation of Version 5.1.0 (Version 5.0.0 + CRs 15r1, 18r1, 21r1, 22r1 & 24r1)
March 1996	Publication of Version 5.1.0