



GSM **T**ECHNICAL **S**PECIFICATION

GSM 02.02

May 1996

Version 5.1.0

Source: ETSI TC-SMG

Reference: TS/SMG-010202QR

ICS: 33.060.50

Key words: Digital cellular telecommunications system, Global System for Mobile communications (GSM)



Digital cellular telecommunications system (Phase 2+); Bearer Services (BS) supported by a GSM Public Land Mobile Network (PLMN); (GSM 02.02)

ETSI

European Telecommunications Standards Institute

ETSI Secretariat

Postal address: F-06921 Sophia Antipolis CEDEX - FRANCE

Office address: 650 Route des Lucioles - Sophia Antipolis - Valbonne - FRANCE

X.400: c=fr, a=atlas, p=etsi, s=secretariat - **Internet:** secretariat@etsi.fr

Tel.: +33 92 94 42 00 - Fax: +33 93 65 47 16

*

Copyright Notification: No part may be reproduced except as authorized by written permission. The copyright and the foregoing restriction extend to reproduction in all media.

© European Telecommunications Standards Institute 1996. All rights reserved.

Contents

Foreword	5
0 Scope	7
0.1 Normative references	7
0.2 Abbreviations	8
1 Framework for defining bearer services.....	8
2 Bearer service categories.....	10
3 Bearer services	11
History.....	14

Blank page

Foreword

This Global System for Mobile communications Technical Specification (GTS) has been produced by the Special Mobile Group (SMG) Technical Committee (TC) of the European Telecommunications Standards Institute (ETSI).

This GTS defines a set of bearer services to be provided within the digital cellular telecommunications system (Phase 2/Phase 2+).

This GTS is a TC-SMG approved GSM technical specification version 5, which contains GSM Phase 2+ enhancements/features to the version 4 GSM technical specification. The ETS on which this Phase 2+ GTS is based is Phase 2 GSM ETS 300 501 (GSM 02.02 version 4.2.2).

GTS are produced by TC-SMG to enable the GSM Phase 2 + specifications to become publicly available, prior to submission for the formal ETSI standards approval procedure to become European Telecommunications Standards (ETS). This ensures the earliest possible access to GSM Phase 2 + specifications for all Manufacturers, Network operators and implementors of the Global System for Mobile communications.

The contents of this GTS are subject to continuing work within TC-SMG and may change following formal TC-SMG approval. Should TC-SMG modify the contents of this GTS it will then be republished by ETSI with an identifying change of release date and an increase in version number as follows:

Version 5.x.y

where:

- y the third digit is incremented when editorial only changes have been incorporated in the specification;

- x the second digit is incremented for all other types of changes, i.e. technical enhancements, corrections, updates, etc.

The specification from which this GTS has been derived was originally based on CEPT documentation, hence the presentation of this GTS may not be entirely in accordance with the ETSI rules.

Reference is made within this TS to GSM-TSs (note).

NOTE: TC-SMG has produced documents which give the technical specifications for the implementation of the digital cellular telecommunications system. Historically, these documents have been identified as GSM Technical Specifications (GSM-TSs). These TSs may have subsequently become I-ETTs (Phase 1), or ETs/ETSI Technical Reports (ETRs) (Phase 2). TC-SMG has also produced ETSI GSM TSs which give the technical specifications for the implementation of Phase 2+ enhancements of the digital cellular telecommunications system. These version 5.x.x GSM Technical Specifications may be referred to as GTs.

Blank page

0 Scope

The purpose of this specification is to define a set of bearer services to be provided to GSM PLMN subscribers by a GSM PLMN itself and in connection with other networks. This specification should also be used as a reference for defining the corresponding required mobile network capabilities which are specified by means of the "GSM PLMN connection type" concept, defined in GSM 03.10.

The recommended provision of the bearer services is under the control of the GSM MoU and is out of the scope of ETSI TC-SMG.

Bearer services not included in this specification that require modifications to the GSM signalling specifications should not be introduced unilaterally by a mobile network operator.

0.1 Normative references

This GTS incorporates by dated and undated reference, provisions from other publications. These normative references are cited at the appropriate places in the text and the publications are listed hereafter. For dated references, subsequent amendments to or revisions of any of these publications apply to this GTS only when incorporated in it by amendment or revision. For undated references, the latest edition of the publication referred to applies.

- [1] GSM 01.04 (ETR 100): "Digital cellular telecommunication system (Phase 2); Abbreviations and acronyms".
- [2] GSM 02.01 (ETS 300 500): "Digital cellular telecommunication system (Phase 2); Principles of telecommunication services supported by a GSM Public Land Mobile Network (PLMN)".
- [3] GSM 02.04 (ETS 300 503): "Digital cellular telecommunication system (Phase 2); General on supplementary service".
- [4] GSM 03.10 (ETS 300 528): "Digital cellular telecommunication system (Phase 2); GSM Public Land Mobile Network (PLMN) connection types".
- [5] GSM 04.02 (ETS 300 551): "Digital cellular telecommunication system (Phase 2); GSM Public Land Mobile Network (PLMN) access reference configuration".
- [6] GSM 07.01 (ETS 300 582): "Digital cellular telecommunication system (Phase 2); General on Terminal Adaptation Functions (TAF) for Mobile Stations (MS)".
- [7] GSM 07.02 (ETS 300 583): "Digital cellular telecommunication system (Phase 2); Terminal Adaptation Functions (TAF) for services using asynchronous bearer capabilities".
- [8] GSM 07.03 (ETS 300 584): "Digital cellular telecommunication system (Phase 2); Terminal Adaptation Functions (TAF) for services using synchronous bearer capabilities".
- [9] GSM 07.05 (ETS 300 585): "Digital cellular telecommunication system (Phase 2); Use of Data Terminal Equipment (DTE)/Data Circuit terminating Equipment (DCE) interface for Short Message Service (SMS) and Cell Broadcast Service (CBS)".
- [10] GSM 09.02 (ETS 300 599): "Digital cellular telecommunication system (Phase 2); Mobile Application Part (MAP) specification".
- [11] GSM 09.03 (ETS 300 600): "Digital cellular telecommunication system (Phase 2); Signalling requirements on interworking between the Integrated Services Digital Network (ISDN) or Public Switched Telephone Network (PSTN) and the Public Land Mobile Network (PLMN)".

- [12] GSM 09.04 (ETS 300 601): "Digital cellular telecommunication system (Phase 2); Interworking between the Public Land Mobile Network (PLMN) and the Circuit Switched Public Data Network (CSPDN)".
- [13] GSM 09.05 (ETS 300 602): "Digital cellular telecommunication system (Phase 2); Interworking between the Public Land Mobile Network (PLMN) and the Packet Switched Public Data Network (PSPDN) for Packet Assembly/Disassembly facility (PAD) access".
- [14] GSM 09.06 (ETS 300 603): "Digital cellular telecommunication system (Phase 2); Interworking between a Public Land Mobile Network (PLMN) and a Packet Switched Public Data Network/Intergrated Services Digital Network (PSPDN/ISDN) for the support of packet switched data transmission services".
- [15] GSM 09.07 (ETS 300 604): "Digital cellular telecommunication system (Phase 2); General requirements on interworking between the Public Land Mobile Network (PLMN) and the Intergrated Services Digital Network (ISDN) or Public Switched Telephone Network (PSTN)".
- [16] GSM 09.10 (ETS 300 605): "Digital cellular telecommunication system (Phase 2); Information element mapping between Mobile Station - Base Station System and BSS - Mobile-services Switching Centre (MS-BSS-MSC) Signalling procedures and the Mobile Application Part(MAP)".
- [17] GSM 09.11 (ETS 300 606): "Digital cellular telecommunication system (Phase 2); Signalling interworking for supplementary services".
- [18] CCITT Recommendation V.120: "Support by an ISDN of data terminal equipments with V-series type interface with provisoin for statistical multiplexing".

0.2 Abbreviations

Abbreviations used in this specification are listed in GSM 01.04.

1 Framework for defining bearer services

Bearer services are described by attributes, which are intended to be independent. These attributes are described and defined in GSM 02.01. They are grouped into four categories:

- i) Information transfer attributes, which characterise the network capabilities for transferring information from a user access point in a GSM PLMN to a user access point in another network. (Refer to GSM 02.01 and 04.02 for definitions of user access points, originating and terminating networks.)
- ii) Access attributes, which describe the means for accessing network functions or facilities as seen at the access point in the PLMN (see GSM 02.01).
- iii) Interworking attributes, which describe properties of the terminating network and its access point. The terminating network may include another GSM PLMN or the originating PLMN (see GSM 02.01).
- iv) General attributes, which deal with the service in general.

Figure 1/GSM 02.02 shows the relation between the groups of attributes and their fields of applicability.

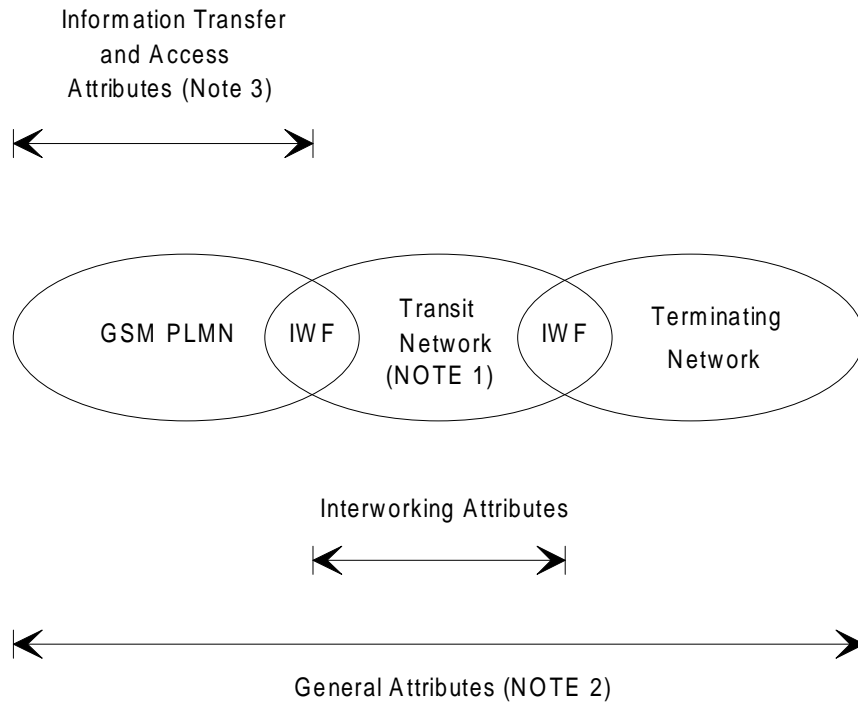

NOTE 1: A transit network may not exist for a bearer service.

NOTE 2: Communication may be established from either end.

NOTE 3: The information transfer and access attributes of a bearer service relate to a direct peer-to-peer communication of:

- TE to TE,
- TE to a network gateway (supporting, for example, PSTN interworking), or
- network gateway to a TE.

Figure 1/GSM 02.02: Relation between the groups of attributes and fields of applicability

The following table lists the individual attributes in each of the four groups. The GSM bearer service definitions in this specification are based on the "Minimal Set" of attributes.

Table 1/GSM 02.02: List of bearer service attributes

	Minimal Set
Information Transfer Attributes	
Information Transfer Mode	X
Information Transfer Rate	X
Information Transfer Capability	X
Establishment of Communication	X
Symmetry	X
Communication Configuration	X
Data Compression	
Access Attributes	
Access Channel and Rate	
Signalling Access Protocols	
Information Access Protocols	
Information Access Structure	X
Information Access Rate	X
Interworking Attributes	
General Attributes	
Supplementary Services Provided	
Quality of Service	X
Operational and Commercial	

Attributes that are not part of the minimal set provide further technical detail and are required to fully define the use of each bearer service.

See the GSM 07-series specifications for information about the Signalling Access Protocols, Information Access Protocols and related access attributes.

GSM supplementary services are defined in GSM 02.04.

Intercommunication is required with services in the PSTN, ISDN, CSPDN and other PLMNs. The capabilities that describe the Interworking Attributes are described in GSM 03.10 and the GSM 09-series specifications.

2 Bearer service categories

All bearer service categories provide information transfer between R/S reference points and allow the use of sub-rate information streams which are rate-adapted.

The bearer services can be grouped into the following categories:

- Unrestricted Digital Information (UDI);
Provides the transfer of unrestricted digital information.
- 3.1 kHz (External to the PLMN);
Used to select a "3.1 kHz audio" interworking function at the MSC. This service category is used when interworking with the ISDN or PSTN "3.1 kHz audio" service and includes the capability to select a modem at the interworking function. "External to the PLMN" indicates that the "3.1 kHz audio" service is only used outside of the PLMN, in the ISDN/PSTN. The connection within the PLMN, user access point to the interworking function, is an unrestricted digital connection.
- PAD;
Provides an asynchronous connection to a PAD. This enables PLMN subscribers to access a packet network (PSPDN/ISDN). See GSM TS 09.05 for service and interworking specifications.

- Packet;
Provides a synchronous connection that enables PLMN subscribers to access a packet network (PSPDN/ISDN). See GSM TS 09.06 for service and interworking specifications.
- Alternate Speech/Data;
Provides the capability to swap between speech and data during a call.

If either the speech or data portion of the call requires a full rate channel, a full rate channel shall be used for the duration of the call.

The access interface at the mobile station for the data portion is assumed to be a standard data interface. Some means must be provided to select the speech/data capability.

- Speech followed by Data;
Provides a speech connection first and then at some time while the call is in progress, the user can switch to a data connection. The user cannot switch back to speech after the data portion.

If either the speech or data portion of the call requires a full rate channel, a full rate channel shall be used from the start of the call. The network may then change to a half rate channel for the data portion.

3 Bearer services

This section provides a list of the existing GSM bearer services and indicates the values for each attribute in the minimal set.

The following attributes have the same value for all GSM bearer services. Their values are as follows:

Information Transfer Mode:	"Circuit"
Information Transfer Rate:	Not applicable (NOTE 1)
Establishment of Communication:	"Demand"
Symmetry:	"Bi-directional Symmetric" (NOTE 2)
Communication Configuration:	"Point to point"

NOTE 1: The Information Transfer Rate attribute is not applicable because it depends on the reference point assumed in the GSM PLMN, transit or terminating network.

NOTE 2: Asynchronous services using 1200/75 bps. require a value of "Bi-directional Asymmetric".

All GSM asynchronous NT bearer services may support data compression to enhance user data throughput.

GSM NT bearer services 2x and 3x may support V.120 interworking, enabling data terminals connected to an MS to interwork with V.120 [18] terminal adapters on the ISDN as shown in the figure 2/GSM 02.02 below.

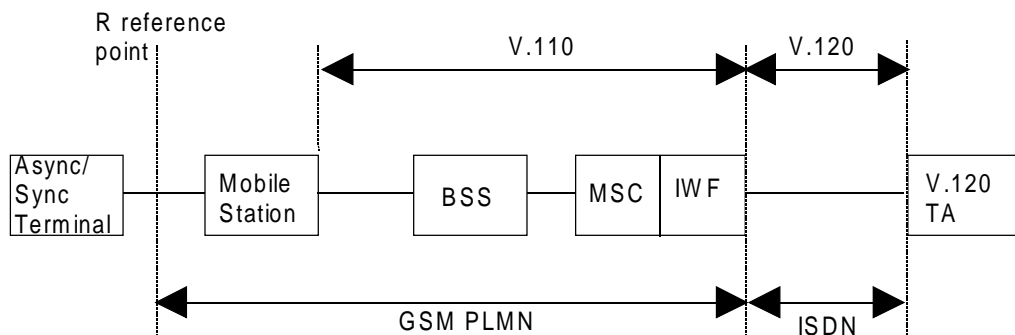

Figure 2/GSM 02.02: Model of GSM V.120 Interworking

Table 2/GSM 02.02 contains the list of the bearer services and the values for the remaining attributes in the minimal set.

Table 2/GSM 02.02

Bearer Service Number	Bearer Service Name	Access Structure	Access Rate	Information Transfer Capability	QOS Attribute	Notes
21	Asynchronous 300 bps	Asynch	300 bps	UDI or 3.1KHz	T or NT	
22	Asynchronous 1.2 kbps	Asynch	1.2 kbps	UDI or 3.1kHz	T or NT	
23	Asynchronous 1200/75 bps	Asynch	1200/75 bps	UDI or 3.1kHz	T or NT	See NOTE 4
24	Asynchronous 2.4 kbps	Asynch	2.4 kbps	UDI or 3.1kHz	T or NT	
25	Asynchronous 4.8 kbps	Asynch	4.8 kbps	UDI or 3.1kHz	T or NT	
26	Asynchronous 9.6 kbps	Asynch	9.6 kbps	UDI or 3.1kHz	T or NT	
31	Synchronous 1.2 kbps	Synch	1.2 kbps	UDI or 3.1kHz	T	
32	Synchronous 2.4 kbps	Synch	2.4 kbps	UDI or 3.1kHz	T or NT	See NOTE 1
33	Synchronous 4.8 kbps	Synch	4.8 kbps	UDI or 3.1kHz	T or NT	See NOTE 1
34	Synchronous 9.6 kbps	Synch	9.6 kbps	UDI or 3.1kHz	T or NT	See NOTE 1
41	PAD Access 300 bps	Asynch	300 bps	UDI	T or NT	See NOTE 2 See NOTE 5
42	PAD Access 1.2 kbps	Asynch	1.2 kbps	UDI	T or NT	See NOTE 2 See NOTE 5
43	PAD Access 1200/75 bps	Asynch	1200/75 bps	UDI	T or NT	See NOTE 2 See NOTE 4 See NOTE 5
44	PAD Access 2.4 kbps	Asynch	2.4 kbps	UDI	T or NT	See NOTE 2 See NOTE 5
45	PAD Access 4.8 kbps	Asynch	4.8 kbps	UDI	T or NT	See NOTE 2 See NOTE 5
46	PAD Access 9.6 kbps	Asynch	9.6 kbps	UDI	T or NT	See NOTE 2 See NOTE 5
51	Packet Access 2.4 kbps	Synch	2.4 kbps	UDI	NT	See NOTE 5
52	Packet Access 4.8 kbps	Synch	4.8 kbps	UDI	NT	See NOTE 5
53	Packet Access 9.6 kbps	Synch	9.6 kbps	UDI	NT	See NOTE 5
61	Alternate Speech/Data					See NOTE 3
81	Speech Followed by Data					See NOTE 3

NOTE 1: The non-transparent versions of Bearer Services 32, 33 and 34 are only specified for the Basic Packet service, defined in GSM 09.06.

NOTE 2: Although the general information transfer capability is UDI, the information transfer capability on the network-specific interface between the IWF and the PAD may be UDI or 3.1 kHz and is the choice of the network operator.

NOTE 3: The data phase of Bearer Services 61 and 81 will be the same as Bearer Services 21 - 34 with "3.1 kHz Information Transfer Capability.

NOTE 4: Bearer service 23 and 43 are applicable to Mobile Originated (MO) calls only. The 75 bps is used in the uplink and the 1200 bps is used in the downlink.

NOTE 5: This bearer service is applicable to Mobile Originated (MO) calls only.

Change history

Change history					
SMG No.	TDoc. No.	CR. No.	Section affected	New version	Subject/Comments
SMG#16	605/95	A001	1.0,3.0	5.0.0	Data Compression
SMG#18	225/96	A002	0.2, 3.0	5.1.0	Provision of V.120 Interworking in GSM

History

Document history	
October 1995	Creation of Version 5.0.0
April 1996	Creation of Version 5.1.0 (CR 0202-A002)
May 1996	Publication of version 5.1.0