



Operational energy Efficiency for Users (OEU); Global KPIs for ICT Sites

Disclaimer

This document has been produced and approved by the Operational energy Efficiency for Users (OEU) ETSI Industry Specification Group (ISG) and represents the views of those members who participated in this ISG. It does not necessarily represent the views of the entire ETSI membership.

Reference

RGS/OEU-0015

Keywords

energy efficiency, user

ETSI

650 Route des Lucioles
F-06921 Sophia Antipolis Cedex - FRANCE

Tel.: +33 4 92 94 42 00 Fax: +33 4 93 65 47 16

Siret N° 348 623 562 00017 - NAF 742 C
Association à but non lucratif enregistrée à la
Sous-Préfecture de Grasse (06) N° 7803/88

Important notice

The present document can be downloaded from:

<http://www.etsi.org>

The present document may be made available in electronic versions and/or in print. The content of any electronic and/or print versions of the present document shall not be modified without the prior written authorization of ETSI. In case of any existing or perceived difference in contents between such versions and/or in print, the only prevailing document is the print of the Portable Document Format (PDF) version kept on a specific network drive within ETSI Secretariat.

Users of the present document should be aware that the document may be subject to revision or change of status. Information on the current status of this and other ETSI documents is available at

<http://portal.etsi.org/tb/status/status.asp>

If you find errors in the present document, please send your comment to one of the following services:

http://portal.etsi.org/chaicor/ETSI_support.asp

Copyright Notification

No part may be reproduced or utilized in any form or by any means, electronic or mechanical, including photocopying and microfilm except as authorized by written permission of ETSI.

The content of the PDF version shall not be modified without the written authorization of ETSI.

The copyright and the foregoing restriction extend to reproduction in all media.

© European Telecommunications Standards Institute 2014.

All rights reserved.

DECT™, **PLUGTESTS™**, **UMTS™** and the ETSI logo are Trade Marks of ETSI registered for the benefit of its Members. **3GPP™** and **LTE™** are Trade Marks of ETSI registered for the benefit of its Members and of the 3GPP Organizational Partners.

GSM® and the GSM logo are Trade Marks registered and owned by the GSM Association.

Contents

Intellectual Property Rights	5
Foreword.....	5
Modal verbs terminology.....	5
Introduction	5
1 Scope	6
2 References	6
2.1 Normative references	6
2.2 Informative references.....	7
3 Definitions, symbols and abbreviations	7
3.1 Definitions	7
3.2 Symbols.....	8
3.3 Abbreviations	8
4 Definition of Key Performance Indicators	8
4.1 Objective KPIs for ICT sites operation	8
4.1.1 Energy Consumption (KPI_{EC}).....	8
4.1.1.1 Generalities	8
4.1.1.2 Scale.....	9
4.1.1.3 Evolution.....	9
4.1.1.4 Formula	9
4.1.1.5 Measurement points and processes	9
4.1.2 Task efficiency (KPI_{TE}).....	10
4.1.2.1 Generalities	10
4.1.2.2 Scale	10
4.1.2.3 Evolution.....	10
4.1.2.4 Formula	10
4.1.2.5 Measurement points and processes	10
4.1.3 Energy reuse (KPI_{REUSE})	11
4.1.3.1 Generalities	11
4.1.3.2 Definition of energy reuse.....	11
4.1.3.3 Scale	11
4.1.3.4 Evolution.....	11
4.1.3.5 Formula	11
4.1.3.6 Measurement points and processes	11
4.1.4 Use of renewable energy (KPI_{REN}).....	12
4.1.4.1 Generalities	12
4.1.4.2 Scale	12
4.1.4.3 Evolution.....	12
4.1.4.4 Formula	12
4.1.4.5 Measurement Points and processes	12
4.2 Global KPI (KPI_{DCEM}) using the Objective KPIs	13
4.2.1 Introduction.....	13
4.2.2 Definition of energy consumption gauge of the DC (DC_G)	13
4.2.3 Definition of performance of the DC (DC_P)	13
4.2.4 Scale.....	14
4.2.5 Evolution	14
4.2.6 Matrix for KPI_{DCEM}	14
4.2.7 Measurement points and processes.....	14
Annex A (normative): Definition of Key Performance Indicators for a group of ICT sites	15
A.1 Global KPI (KPI_{DCEM}) using the Objective KPIs for a group of ICT sites.....	15
A.1.1 Introduction	15
A.1.2 Energy Consumption (KPI_{ECG}) formula	15

A.1.3	Definition of energy consumption gauge of a group of ICT sites (DC_{GG})	15
A.1.4	Definition of the class of a group of ICT sites.....	15
A.1.5	Scale	15
A.1.6	Evolution	16
Annex B (informative): The status of Key Performance Indicators (KPIs).....		17
B.1	Technical KPIs	17
B.2	Objective KPIs	17
B.3	Global KPIs	18
B.4	Summary	18
Annex C (informative): Energy Consumption per square metre (KPI_{ECI})		19
C.1	Generalities.....	19
C.2	Scale	19
C.3	Evolution	19
C.4	Formula	19
C.5	Measurement points and procedures	19
	History	20

Intellectual Property Rights

IPRs essential or potentially essential to the present document may have been declared to ETSI. The information pertaining to these essential IPRs, if any, is publicly available for **ETSI members and non-members**, and can be found in ETSI SR 000 314: *"Intellectual Property Rights (IPRs); Essential, or potentially Essential, IPRs notified to ETSI in respect of ETSI standards"*, which is available from the ETSI Secretariat. Latest updates are available on the ETSI Web server (<http://ipr.etsi.org>).

Pursuant to the ETSI IPR Policy, no investigation, including IPR searches, has been carried out by ETSI. No guarantee can be given as to the existence of other IPRs not referenced in ETSI SR 000 314 (or the updates on the ETSI Web server) which are, or may be, or may become, essential to the present document.

Foreword

This Group Specification (GS) has been produced by ETSI Industry Specification Group (ISG) Operational energy Efficiency for Users (OEU).

Modal verbs terminology

In the present document "shall", "shall not", "should", "should not", "may", "may not", "need", "need not", "will", "will not", "can" and "cannot" are to be interpreted as described in clause 3.2 of the [ETSI Drafting Rules](#) (Verbal forms for the expression of provisions).

"**must**" and "**must not**" are **NOT** allowed in ETSI deliverables except when used in direct citation.

Introduction

Further to the 1997 Kyoto protocol [i.7], the European Commission has issued, and will issue, Directives in order to improve energy management of networks, sites included, of whole industry sectors.

Therefore suppliers and users of information and communication technology (ICT) equipment are obliged to implement "Green" tools (indicators, recognized Green levels) to monitor the efficiency of their greener networks.

ICT sites constitute one of the most important areas of the worldwide growing energy consumption. Consequently, the first target of ETSI ISG OEU has been the development of this Position Paper defining appropriate Objective and Global Key Performance Indicators (KPIs) to be used for operational ICT sites.

The present document has been developed by ISG OEU members (ICT world Users) supported by the CTO Alliance/CRIP in order to define the most efficient tools.

The present document presents the Objective KPIs of the ETSI ES 205 200-2-1 [2] in a simple format and uses them to define a Global KPI which indicates data centre energy usage and efficiency. It is expected that the present document will influence the development and maintenance of the ETSI ES 205 200 Series [i.8] under the responsibility of ETSI ATTM.

1 Scope

The present document defines the current position of the ISG OEU members in relation to the so-called Global Key Performance Indicators (Global KPIs) enabling the monitoring of data centre (DC) energy management.

The present document defines Global Key Performance Indicators in relation to energy management for ICT sites including, but not limited to: operator data centres (ODC), operator sites (OS) and customer data centres (CDC). It addresses the following objectives:

- energy consumption;
- task efficiency;
- energy reuse;
- renewable energy.

The present document defines:

- four KPIs addressing these objectives (Objective KPIs);
- one Global KPI which combines the four Objective KPIs.

The Objective and Global KPIs defined here apply to ICT sites of any size from initial operation to end of life.

2 References

References are either specific (identified by date of publication and/or edition number or version number) or non-specific. For specific references, only the cited version applies. For non-specific references, the latest version of the referenced document (including any amendments) applies.

Referenced documents which are not found to be publicly available in the expected location might be found at <http://docbox.etsi.org/Reference>.

NOTE: While any hyperlinks included in this clause were valid at the time of publication, ETSI cannot guarantee their long term validity.

2.1 Normative references

The following referenced documents are necessary for the application of the present document.

- [1] ETSI ES 205 200-1: "Access, Terminals, Transmission and Multiplexing (ATTM); Energy management; Global KPIs; Operational infrastructures; Part 1: General requirements".
- [2] ETSI ES 205 200-2-1: "Access, Terminals, Transmission and Multiplexing (ATTM); Energy management; Global KPIs; Operational infrastructures; Part 2: Specific requirements; Sub-part 1: Data centres".
- [3] CENELEC EN 50600 Series: "Information technology - Data centre facilities and infrastructures".
- [4] CENELEC EN 1434 Series: "Heat meters".

2.2 Informative references

The following referenced documents are not necessary for the application of the present document but they assist the user with regard to a particular subject area.

- [i.1] EC Mandate M/462: "Standardisation mandate addressed to CEN, CENELEC and ETSI in the field of ICT to enable efficient energy use in fixed and mobile information and communication networks".
- [i.2] ETSI TS 105 174-2-2: "Access, Terminals, Transmission and Multiplexing (ATTM); Broadband Deployment - Energy Efficiency and Key Performance Indicators; Part 2: Network sites; Sub-part 2: Data centres".
- [i.3] European Commission DG JRC: "Code of Conduct for Data Centre Energy Efficiency".
- [i.4] Recommendation ITU-T L.1300: "Series L: Construction, installation and protection of cables and other elements of outside plant: Best practices for green data centers".
- [i.5] European Commission DG JRC: "Code of Conduct on Energy Consumption of Broadband Equipment".
- [i.6] ETSI TS 105 174-1: "Access, Terminals, Transmission and Multiplexing (ATTM); Broadband Deployment and Energy Management; Part 1: Overview, common and generic aspects".
- [i.7] Kyoto Protocol to the United Nations Framework Convention on Climate Change.
- [i.8] ETSI ES 205 200 Series: "Access, Terminals, Transmission and Multiplexing (ATTM); Energy management; Global KPIs; Operational infrastructures".
- [i.9] Directive 2010/31/EU of the European parliament and of the council of 19 May 2010 on the energy performance of buildings.

3 Definitions, symbols and abbreviations

3.1 Definitions

For the purposes of the present document, the following terms and definitions apply:

energy consumption: annual energy consumption required for proper operation of the data centre, expressed as KWh whatever the power source is (utility or local)

energy consumption per square metre: energy consumption expressed as KWh per sqm of "occupied" IT room

fossil energy: fuel, coal, gas, etc.

Global Key Performance Indicator (Global KPI): KPI allowing benchmarking the energy management of ICT sites (data centres included) depending on their gauge

objective KPI: KPI assessing one of the objectives of operational energy performance which is subsequently used to define the Global KPI for energy management

renewable energy: solar, wind, hydrothermal, geothermal, etc.

3.2 Symbols

For the purposes of the present document, the following symbols apply:

DC_G	Data Centre Gauge
DC_P	Data Centre Performance
EC_{DC}	Total of energy consumptions by a data centre over a year
EC_{FEN}	Consumption of locally generated electricity based on fossil energy
EC_{HE}	Total of energy consumptions by equipment processing data, for purposes of calculating, storing or transporting, over a year
EC_{REN}	Consumption of locally generated electricity based on renewable sources
EC_{REUSE}	Total of energy consumption from reused energy
EC_{SP}	Consumption of utility electricity
EC_{TH}	Energy consumption from externally-provided thermal energy (either hot or cold)
EER	Energy Efficiency Ratio expressed as thermal kWh extracted by one electrical kWh
KPI_{DCEM}	Global KPI for data centre energy management
KPI_{EC}	Objective KPI for "Energy Consumption"
KPI_{ECI}	KPI for "Energy consumption per square metre"
KPI_{REN}	Objective KPI for "Renewable Energy"
KPI_{REUSE}	Objective KPI for "Energy Reuse"
KPI_{TE}	Objective KPI for "Task Efficiency"
K_{TH}	Conversion ratio from thermal energy to electricity
W_{CRs}	CRs mitigation ratio; ranges from 0 to 1
W_{REN}	Mitigation factor for KPI_{REN}
W_{REUSE}	Mitigation factor for KPI_{REUSE}

3.3 Abbreviations

For the purposes of the present document, the following abbreviations apply:

CDC	Customer Data Centre
DC	Data Centre
EC DG JRC	European Commission Directorate General Joint Research Centre
FIT4Green	Project funded by Cooperation-ICT within European Commission Programme FP7
GAMES	Project funded by Cooperation-ICT within European Commission Programme FP7
GWh	Giga Watt Hour
ICT	Information and Communication(s) Technology
IT	Information Technology
ITE	IT Equipment
KPI	Key Performance Indicator
NTE	Network Telecommunications Equipment
ODC	Operator Data Centre
OS	Operator Site

4 Definition of Key Performance Indicators

4.1 Objective KPIs for ICT sites operation

4.1.1 Energy Consumption (KPI_{EC})

4.1.1.1 Generalities

The present document applies the requirements of KPI_{EC} of ETSI ES 205 200-2-1 [2] in a simple format. It is expected that the present document will influence the development and maintenance of the ETSI ES 205 200 Series [i.8] under the responsibility of ETSI ATTM.

Several standards and technical documents have been taken into account during the development of the present document including EC Mandate M/462 [i.1], ETSI ES 205 200-1 [1], ETSI TS 105 174-1 [i.6], ETSI TS 105 174-2-2 [i.2], CENELEC EN 50600 Series [3], Recommendation ITU-T L.1300 [i.4], and EC DG JRC Code of Conduct for Data Centres [i.3] and [i.5].

The energy consumption to be included in KPI_{EC} comprises that of buildings containing IT rooms, technical infrastructure and spaces required for proper operation of the ICT sites (including, but not limited to: security, guards, maintenance, management of IT rooms).

Energy consumption excluded from this KPI includes buildings containing offices for on-site employees, including, but not limited to: project managers, application integrators, system experts, etc.

4.1.1.2 Scale

KPI_{EC} applies to all ICT sites of all sizes and includes IT rooms located in buildings.

4.1.1.3 Evolution

KPI_{EC} applies to all states of ICT sites, from initial operation to end of life.

4.1.1.4 Formula

$$KPI_{EC} = EC_{DC} = EC_{SP} + EC_{FEN} + EC_{REN} + (EC_{TH} \times K_{TH})$$

4.1.1.5 Measurement points and processes

Utility energy (EC_{SP}):

- counter values and/or sub counters of the electricity provider feeding the site - these counters shall be certified by the electricity providers;
- electricity coming from an internal electricity distribution loop: DC input counter readings, taking into account the losses in transformers.

Electricity based on fossil local power sources (EC_{FEN}): local sub-counters readings:

- at the power sources output, when dedicated to the DC;
- at the DC entry, for power sources shared with other usages.

Energy based on renewable local power sources (EC_{REN}): local sub-counters readings:

- at the power sources output, when dedicated to the DC;
- at the DC entry, for power sources shared with other usages.

Energy based on thermal energy (EC_{TH}): measured by a calories counter / integrator at the DC entry:

- according to CENELEC EN 1434 Series [4] where the distribution loop is considered a closed loop;
- the same method is used for reused energy (EC_{REUSE}) - see clause 4.1.3.6.

Energy based on Aeraulics power source:

- the measurement of aeraulics-based energy is done by integrating the mass flow rate by the difference of temperature of the consuming point, the network being considered an open loop;
- the same method is used for reused energy(EC_{REUSE}) - see clause 4.1.3.6.

Remarks:

- Assessed energy consumption excludes spaces that are not directly related to the function and/or operation of the data centre(i.e. includes those spaces for guards, management and maintenance personnel).

- Only electricity consumption is measured, not the primary energy consumption. Nevertheless the non-electrical energy sources have to be converted in electricity equivalent in order to remain homogeneous.
- For EC_{TH} , the conversion factor if known and certified should be used as K_{TH} , using a margin to take into account the distribution losses. If not known, a default $K_{TH} = 0,43$ corresponding to a reference installation using chillers with air condensing shall be used.

NOTE: Network losses: 8 %; EER: 2,5 => $K_{TH} = 1 / (1 - 0,08) \times 2,5$.

4.1.2 Task efficiency (KPI_{TE})

4.1.2.1 Generalities

The present document applies the requirements of KPI_{TE} of ETSI ES 205 200-2-1 [2] in a simple format. It is expected that the present document will influence the development and maintenance of the ETSI ES 205 200 Series [i.8] under the responsibility of ETSI ATTM.

KPI_{TE} is the ratio of the electricity consumption of all the components, whatever they are, to that of the components that manage data, for calculation storage or transport purposes. KPI_{TE} is dimensionless and has the following properties:

- $KPI_{TE} \geq 1$;
- $KPI_{TE} = 1$ is an ideal value;
- a KPI_{TE} of between 2 and 2,5 is frequently reached.

All components transforming electricity or improving availability are to be taken into account.

All equipment downstream of the energy sources (including, but not limited to: lighting, cooling, safety, security, power distribution, devices extracting heat for reusing energy, devices used to extract renewable energy) are to be considered. An energy source can be either internal or external.

Should this remind the "Power Usage Effectiveness", the difference is in the definition so that everybody counts the same things.

The improvement margins allow winning several tenths. The last tenths are not attainable without changing infrastructures or technical innovations. This means the KPI_{TE} will not improve, and it is then necessary to rethink the whole data centre, including the physical part.

4.1.2.2 Scale

KPI_{TE} applies to all ICT sites of all sizes and includes IT rooms located in buildings.

4.1.2.3 Evolution

KPI_{TE} applies to all states of ICT sites, from initial operation to end of life.

4.1.2.4 Formula

$$KPI_{TE} = \frac{EC_{DC}}{EC_{HE}}$$

4.1.2.5 Measurement points and processes

The measurement points for electricity consumption are to be done externally to that component, nearest to its input and its output when transforming or securing.

When the measurement point is not close to the consumption point, standard ETSI ES 205 200-2-1 [2] gives guidance on how to compensate the measurement.

Measurements should be done in kWh and can be approximated by using regular power measurements.

Measurement shall be done over a yearly period, so as to take into account the yearly climate changes.

4.1.3 Energy reuse (KPI_{REUSE})

4.1.3.1 Generalities

The present document applies the requirements of KPI_{REUSE} of ETSI ES 205 200-2-1 [2] in a simple format. It is expected that the present document will influence the development and maintenance of the ETSI ES 205 200 Series [i.8] under the responsibility of ETSI ATTM.

KPI_{REUSE} is the ratio of reused energy for external uses to total data centre energy. Thermal energy can be reused in different forms, liquid or gas (air). KPI_{REUSE} shall be measurable and quantifiable and results in a dimensionless number.

An example is the number of hours for heating offices reusing energy, and the floor space of offices heated that way, on the basis that one square metre of office space heated at 20 °C is equivalent to 16 watts of electrical heating.

NOTE: The reused energy should be mitigated by an efficiency factor depending on the heat transport system, whether air or water.

Extensions of KPI_{REUSE} to other kinds of energy reuse than the one described above could be studied.

4.1.3.2 Definition of energy reuse

Energy efficiency of ICT sites is an important matter. It is now essential if not vital to implement commitments in order to reduce the energy consumption by ICT sites. Indeed the ICT area is responsible for at least 2 % of the greenhouse gas emissions in the world and continues to grow.

Possible initiatives to reuse the calories produced by information technology equipment (ITE) and network telecommunications equipment (NTE) in ICT sites include:

- water heating;
- heating of nearby offices;
- heating of nearby apartments;
- warming of arboretums;
- pre-heating of diesel engines.

It is obvious that the viability of energy reuse will depend on data centre configurations.

4.1.3.3 Scale

KPI_{REUSE} applies to all ICT sites of all sizes and includes IT rooms located in buildings.

4.1.3.4 Evolution

KPI_{REUSE} applies to all states of ICT sites, from initial operation to end of life.

4.1.3.5 Formula

$$KPI_{REUSE} = \frac{EC_{REUSE}}{EC_{DC}}$$

4.1.3.6 Measurement points and processes

According to methodology defined in clause 4.1.1.5.

Measurement equipments shall be nearest to the reused energy consumption points so as to take into account the losses in the distribution circuits.

When using a complex distribution circuit for reuse (several scattered consumers) it is possible to locate the measuring equipment at the DC output and then apply a mitigating factor to EC_{REUSE} to take into account the losses in the distribution circuit.

When no measurement procedure is available, an approved external certification company will certify the measurement.

4.1.4 Use of renewable energy (KPI_{REN})

4.1.4.1 Generalities

The present document applies the requirements of KPI_{REN} of ETSI ES 205 200-2-1 [2] in a simple format. It is expected that the present document will influence the development and maintenance of the ETSI ES 205 200 Series [i.8] under the responsibility of ETSI ATTM.

KPI_{REN} is the ratio of local renewable energy over the total data centre energy consumption. It is a dimensionless number.

An energy source is considered renewable when it uses renewable natural energy and that the conventional energy required to value it is less than 10 % of the produced energy.

"energy from renewable sources" means energy from renewable non-fossil sources, namely wind, solar, aero thermal, geothermal, hydrothermal and ocean energy, hydropower, biomass, landfill gas, sewage treatment plant gas and biogases.

NOTE: According to Directive 2010/31/EU [i.9] on the Energy Performance of Building.

Only the sources contributing to data centre operations will be taken into account, whether dedicated or shared.

4.1.4.2 Scale

KPI_{REN} applies to all ICT sites of all sizes and includes IT rooms located in buildings.

4.1.4.3 Evolution

KPI_{REN} applies to all states of ICT sites, from initial operation to end of life.

4.1.4.4 Formula

$$KPI_{REN} = \frac{EC_{REN}}{EC_{DC}}$$

4.1.4.5 Measurement Points and processes

According to methodology defined in clause 4.1.1.6.

The quantity of energy coming from renewable sources is the total of energy coming from such sources, used by the data centre, minus the traditional energy required to produce or deliver this energy to the consumption point.

All the measurements shall be done over the same evaluation period.

This KPI shall be considered only if the amount of conventional energy required to produce it is no greater than 10 % of the produced renewable energy.

4.2 Global KPI ($KPI_{DC_{EM}}$) using the Objective KPIs

4.2.1 Introduction

The set of Objective KPIs defined in the clause 4.1 are used to define a Global KPI ($KPI_{DC_{EM}}$) that allows benchmarking the energy management efficiency of ICT sites depending on their gauge.

$KPI_{DC_{EM}}$ is composed of two values, DC_G and DC_P , where:

- DC_G defines the energy consumption gauge of the DC;
- DC_P defines the performance of the DC for the relevant gauge.

4.2.2 Definition of energy consumption gauge of the DC (DC_G)

The default number of DC_G gauges is 4 as shown in table 1 can be adapted by the user of the $KPI_{DC_{EM}}$.

Table 1: Default Gauges (DC_G)

DC_G	KPI_{EC} range
S	$KPI_{EC} \leq 1$ GWh
M	$1 \text{ GWh} < KPI_{EC} \leq 4$ GWh
L	$4 \text{ GWh} < KPI_{EC} \leq 20$ GWh
XL	$KPI_{EC} > 20$ GWh

4.2.3 Definition of performance of the DC (DC_P)

The calculation of DC_P is addressed below in the table 2. Default classes are as shown in table 2.

Table 2: Default Classes of DC_P

DC commissioning date	since 2005 (see note)		before 2005 (see note)	
	DC_P		DC_P	
Class	\geq	$<$	\geq	$<$
A		0,70		1,00
B	0,70	1,00	1,00	1,40
C	1,00	1,30	1,40	1,70
D	1,30	1,50	1,70	1,90
E	1,50	1,70	1,90	2,10
F	1,70	1,90	2,10	2,30
G	1,90	2,10	2,30	2,50
H	2,10	2,40	2,50	2,70
I	2,40		2,70	

NOTE: Year of Kyoto Protocol entering into force.

The following formula applies to the calculation of DC_P for all the gauges:

$$DC_P = KPI_{TE} \times (1 - W_{REUSE} \times KPI_{REUSE}) \times (1 - W_{REN} \times KPI_{REN})$$

where:

W_{REUSE} = Mitigation factor for KPI_{REUSE} (the value may vary depending on the gauge (ffs) within the range 0 to 1, the default value is 0,5).

W_{REN} = Mitigation factor for KPI_{REN} (the value may vary depending on the gauge (ffs) within the range 0 to 1, the default value is 0,5).

4.2.4 Scale

KPI_{DCEM} applies to all ICT sites of all sizes and includes IT rooms located in buildings.

4.2.5 Evolution

KPI_{DCEM} applies to all states of ICT sites, from initial operation to end of life.

4.2.6 Matrix for KPI_{DCEM}

The Global KPI_{DCEM} is presented as a combination of the two values, DC_G and DC_P , in the following form: Gauge (see table 1), Class (see table 2) e.g. M, E.

4.2.7 Measurement points and processes

According to methodology defined in clause 4.1.

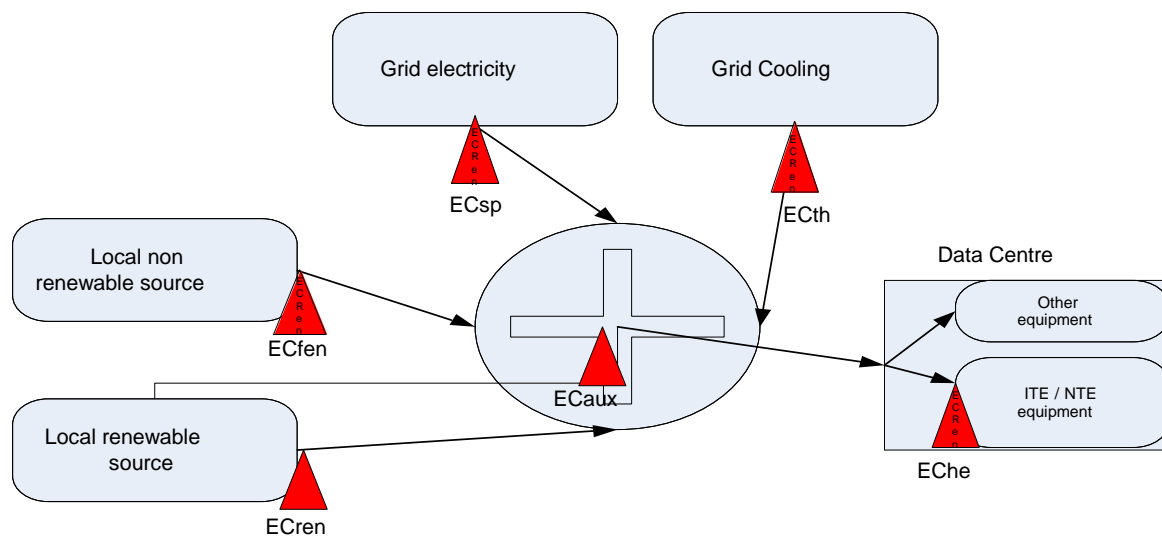

Figure 1: Energy measurement points

Annex A (normative): Definition of Key Performance Indicators for a group of ICT sites

A.1 Global KPI (KPI_{DCEM}) using the Objective KPIs for a group of ICT sites

A.1.1 Introduction

The set of Objective KPIs as defined in clause 4.1 are used to define a Global KPI (KPI_{DCEM}) for a group of ICT sites allows benchmarking the energy management efficiency of a group of ICT sites depending on its gauge.

DC_{EM} is composed of two values: Energy consumption Gauge and Class. The Gauge depends on the global energy consumption by all the ICT sites in the group and the Class is a weighted average of all ICT classes.

NOTE: DC_P is not used in the calculation of classes for group of ICT sites.

A.1.2 Energy Consumption (KPI_{ECG}) formula

For a Group of ICT sites:
$$KPI_{ECG} = \sum_{i=1}^n KPI_{EC}(i)$$

Where $KPI_{EC}(i) = KPI_{EC}$ for ICT site i

A.1.3 Definition of energy consumption gauge of a group of ICT sites (DC_{GG})

For groups of ICT sites, gauges are not used. The actual consumption KPI_{ECG} is reported in combination within the group class.

KPI_{ECG} is the total consumption of energy by the group of ICT sites as defined in clause A.1.2.

A.1.4 Definition of the class of a group of ICT sites

The class associated with a group of ICT sites is a weighted average of all ICT sites classes.

$$NumClassG = \frac{\sum_{i=1}^n NumClass(i) * KPI_{EC}(i)}{\sum_{i=1}^n KPI_{EC}(i)}$$

Where NumClass = class number, A=1...I=9

A.1.5 Scale

KPI_{DCEM} applies to all groups of ICT sites of all sizes.

A.1.6 Evolution

KPI_{DCEM} applies to all states of ICT sites in a group, from initial operation to end of life.

Annex B (informative): The status of Key Performance Indicators (KPIs)

B.1 Technical KPIs

Individual components or sub-assemblies can be designed to have improved task efficiency i.e. less energy is consumed for a given output or task. Such components or sub-assemblies may be inherently more efficient in the way in which they use energy under specific operating conditions but are essentially unable to manage that consumption. An example of such a product would be a power supply unit which may be more efficient under higher load conditions.

More complex products may contain hardware and/or software which automatically reduce energy consumption under specific operating conditions by putting certain functions into "idle" states if not required. This is distinctly different than that of a single task component or sub-assembly detailed above.

Technical KPIs can be applied to both of the above by assessing energy consumption for a number of specific operating conditions and also across a combination of such operating conditions. Assuming those operating conditions reflect the probable operating environment for the component, sub-assembly or product, a customer may make valued judgements in relation to the appropriateness of the Technical KPI.

For example, two products that have equal "combined" Technical KPIs, may be more efficient under very specific conditions. For example, a design of power supply that is more task efficient under high load conditions may be inappropriate for users who plan to predominantly operate under low load conditions (and vice versa).

A higher level of task efficiency management is also possible where groups of products are managed to reduce energy consumption by either allocating loads in such a way that the group is operating at maximum task efficiency and/or by putting individual products within the group into an "idle" mode. Examples of such managed solutions are seen in data centre software plug-ins (such as those developed under the Fit4Green and GAMES projects funded by the European Commission) and in documents developed by ETSI TC EE. Once again, the value of such approaches can be validated by the establishment of Technical KPIs which can be applied to both of the above by assessing energy consumption of a defined group of products for a number of specific operating conditions and also across a combination of such operating conditions.

Figure B.1 provides a schematic in relation to energy-related KPIs. The left-hand side of that schematic relates to the Technical KPIs of the design and engineering phase for components, sub-assemblies, products and systems.

B.2 Objective KPIs

The Objective KPIs described in the documents of the ETSI ES 205 200 series [i.8] relate to specific elements of energy management described in clause B.1 for operational infrastructures under the control of operators as follows:

- energy consumption: the total consumption of energy by an operational infrastructure;
- task efficiency: a measure of the work done (as a result of design and/or operational procedures) for a given amount of energy consumed;
- energy re-use: transfer or conversion of energy (typically in the form of heat) produced by the operational infrastructure to do other work;
- renewable energy: energy produced from dedicated generation systems using resources that are naturally replenished.

The procurement of products and systems based upon their Technical KPIs for energy consumption and/or task efficiency underpins the relevant Objective KPIs. However, the ETSI ES 205 200 series documents [i.8] define requirements for the measurement of those Objective KPIs for operational infrastructures i.e. taking into account the real operating conditions over a defined period of time.

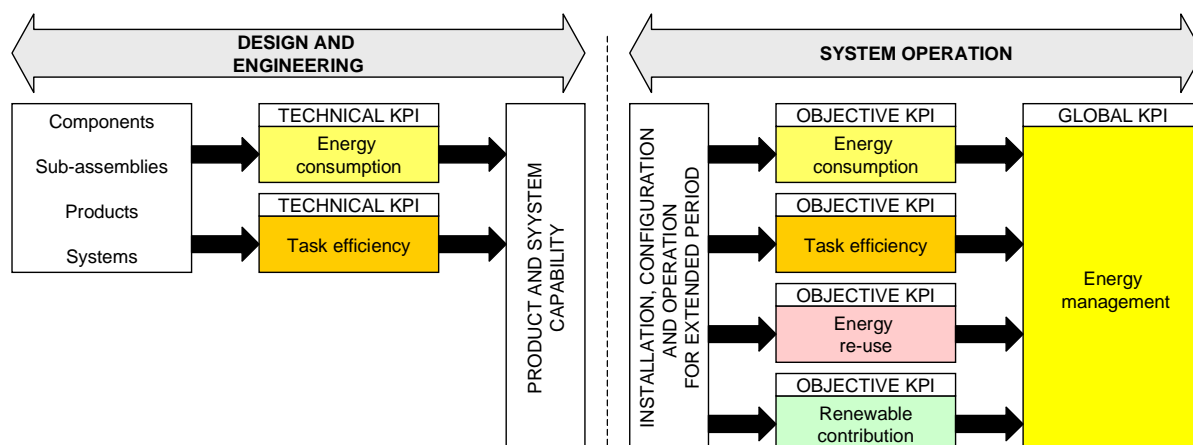

Figure B.1: The relationship of energy-related Technical, Objective and Global KPIs

Technical KPIs for energy consumption and task efficiency performance of products and systems are established at the design and engineering stages. Actual performance of products and systems may differ when the operating conditions lie outside of those applied when measuring these technical KPIs, and are equally important when subjected to user configuration and controls which may undermine the sophisticated systems available.

The right-hand side of the schematic in figure B.1 relates to the Objective KPIs of complete infrastructures in the operational phase.

B.3 Global KPIs

The Objective KPIs, of which task efficiency is one element, are using a formula appropriate to the specific operational infrastructure to produce a Global operational KPI. The Global operational KPI reflects the overall performance of the operational infrastructures against wider energy management targets which may be self-imposed by the operators or externally applied by legislators.

Global KPIs provide a wider view of a user's commitment to strategic energy management practices than the Objective KPIs. For example, achieving class-leading provision of local renewable energy together with very poor task efficiency does not meet overall energy goals.

B.4 Summary

Global Operational KPIs and Objective KPIs are fundamentally different to the Technical KPIs applied to products and systems at the design and engineering stages. The former are used to monitor and drive user behaviour whereas the latter are substantial indications of potential operational performance.

It is therefore important to support, but differentiate, the role of the Technical KPIs from the Objective and Global operational KPIs.

Annex C (informative): Energy Consumption per square metre (KPI_{EC1})

C.1 Generalities

KPI_{EC1} is calculated from KPI_{EC} and takes into account the IT room floor space.

C.2 Scale

KPI_{EC1} applies to all ICT sites of all sizes and includes IT rooms located in buildings.

C.3 Evolution

KPI_{EC1} applies to all states of ICT sites, from initial operation to end of life.

C.4 Formula

$$KPI_{EC1} = \left(\frac{KPI_{EC}}{(1 + W_{CRs}) \times (CRs - 1)} \right)$$

where:

- CRs = IT room floor space used (by racks, networking, disk arrays and tape robots) = raw footprint of IT and Telco equipment).
 W_{CRs} = CRs mitigation ratio; ranges from 0 to 1.

C.5 Measurement points and procedures

See clause 4.1.1.4.

History

Document history		
V1.1.1	January 2013	Publication
V1.2.1	April 2013	Publication
V1.2.2	May 2013	Publication
V1.2.3	July 2013	Publication
V1.2.4	October 2014	Publication
V2.1.1	December 2014	Publication