



GROUP SPECIFICATION

Network Functions Virtualisation (NFV) Release 4; Management and Orchestration; Network Service Templates Specification

Disclaimer

The present document has been produced and approved by the Network Functions Virtualisation (NFV) ETSI Industry Specification Group (ISG) and represents the views of those members who participated in this ISG.
It does not necessarily represent the views of the entire ETSI membership.

Reference

RGS/NFV-IFA014ed421

Keywords

MANO, network, NFV, service, virtualisation

ETSI

650 Route des Lucioles
F-06921 Sophia Antipolis Cedex - FRANCE

Tel.: +33 4 92 94 42 00 Fax: +33 4 93 65 47 16

Siret N° 348 623 562 00017 - APE 7112B
Association à but non lucratif enregistrée à la
Sous-Préfecture de Grasse (06) N° w061004871

Important notice

The present document can be downloaded from:

<http://www.etsi.org/standards-search>

The present document may be made available in electronic versions and/or in print. The content of any electronic and/or print versions of the present document shall not be modified without the prior written authorization of ETSI. In case of any existing or perceived difference in contents between such versions and/or in print, the prevailing version of an ETSI deliverable is the one made publicly available in PDF format at www.etsi.org/deliver.

Users of the present document should be aware that the document may be subject to revision or change of status.

Information on the current status of this and other ETSI documents is available at

<https://portal.etsi.org/TB/ETSIDeliverableStatus.aspx>

If you find errors in the present document, please send your comment to one of the following services:

<https://portal.etsi.org/People/CommitteeSupportStaff.aspx>

Notice of disclaimer & limitation of liability

The information provided in the present deliverable is directed solely to professionals who have the appropriate degree of experience to understand and interpret its content in accordance with generally accepted engineering or other professional standard and applicable regulations.

No recommendation as to products and services or vendors is made or should be implied.

No representation or warranty is made that this deliverable is technically accurate or sufficient or conforms to any law and/or governmental rule and/or regulation and further, no representation or warranty is made of merchantability or fitness for any particular purpose or against infringement of intellectual property rights.

In no event shall ETSI be held liable for loss of profits or any other incidental or consequential damages.

Any software contained in this deliverable is provided "AS IS" with no warranties, express or implied, including but not limited to, the warranties of merchantability, fitness for a particular purpose and non-infringement of intellectual property rights and ETSI shall not be held liable in any event for any damages whatsoever (including, without limitation, damages for loss of profits, business interruption, loss of information, or any other pecuniary loss) arising out of or related to the use of or inability to use the software.

Copyright Notification

No part may be reproduced or utilized in any form or by any means, electronic or mechanical, including photocopying and microfilm except as authorized by written permission of ETSI.

The content of the PDF version shall not be modified without the written authorization of ETSI.

The copyright and the foregoing restriction extend to reproduction in all media.

© ETSI 2021.
All rights reserved.

Contents

Intellectual Property Rights	7
Foreword.....	7
Modal verbs terminology.....	7
1 Scope	8
2 References	8
2.1 Normative references	8
2.2 Informative references.....	8
3 Definition of terms, symbols and abbreviations.....	9
3.1 Terms.....	9
3.2 Symbols.....	9
3.3 Abbreviations	9
4 Overview	10
4.1 Network Service Descriptions.....	10
4.2 Relation to other ETSI NFV Group Specifications	11
4.3 Conventions.....	11
5 Functional requirements	12
5.1 Void.....	12
5.2 Functional requirements for Network Service Descriptor	12
5.3 Functional requirements for Network Service Deployment Flavour.....	13
5.4 Functional requirements for VNF Forwarding Graph Descriptor	14
5.5 Functional requirements for Virtual Link Descriptor	14
5.6 Functional requirements for Physical Network Function Descriptor	14
5.7 Functional requirements for PNF archive.....	15
6 Descriptors formats and contents	15
6.1 Void.....	15
6.2 Information elements related to the Network Service Descriptor	15
6.2.1 Introduction.....	15
6.2.2 Network Service Descriptor information element	16
6.2.2.1 Description	16
6.2.2.2 Attributes.....	16
6.2.3 Sapid information element.....	17
6.2.3.1 Description	17
6.2.3.2 Attributes.....	18
6.2.4 Void	18
6.2.5 SecurityParameters information element	18
6.2.5.1 Description	18
6.2.5.2 Attributes.....	18
6.2.6 MonitoredData information element.....	18
6.2.6.1 Description	18
6.2.6.2 Attributes.....	18
6.2.7 VnfIndicatorData information element	19
6.2.7.1 Description	19
6.2.7.2 Attributes.....	19
6.2.8 MonitoringParameter information element.....	19
6.2.8.1 Description	19
6.2.8.2 Attributes.....	19
6.2.9 LifeCycleManagementScript information element.....	20
6.2.9.1 Description	20
6.2.9.2 Attributes.....	20
6.2.10 Information elements related to NS lifecycle management operations.....	20
6.2.10.1 Introduction.....	20
6.2.10.2 NsLcmAdditionalParams information element.....	20
6.2.10.2.1 Description	20

6.2.10.2.2	Attributes	20
6.2.10.3	InstantiateNsAdditionalParams information element.....	21
6.2.10.3.1	Description	21
6.2.10.3.2	Attributes	21
6.2.10.4	ScaleNsAdditionalParams information element.....	21
6.2.10.4.1	Description	21
6.2.10.4.2	Attributes	21
6.2.10.5	HealNsAdditionalParams information element.....	21
6.2.10.5.1	Description	21
6.2.10.5.2	Attributes	21
6.3	Information elements related to the Network Service Deployment Flavour	22
6.3.1	Introduction.....	22
6.3.2	NsDf information element	22
6.3.2.1	Description	22
6.3.2.2	Attributes.....	22
6.3.3	VnfProfile information element.....	23
6.3.3.1	Description	23
6.3.3.2	Attributes.....	23
6.3.4	VirtualLinkProfile information element	25
6.3.4.1	Description	25
6.3.4.2	Attributes.....	25
6.3.5	AffinityOrAntiAffinityGroup information element.....	26
6.3.5.1	Description	26
6.3.5.2	Attributes.....	26
6.3.6	PnfProfile information element.....	26
6.3.6.1	Description	26
6.3.6.2	Attributes.....	26
6.3.7	NsVirtualLinkConnectivity information element	27
6.3.7.1	Description	27
6.3.7.2	Attributes.....	27
6.3.8	LocalAffinityOrAntiAffinityRule information element.....	27
6.3.8.1	Description	27
6.3.8.2	Attributes.....	28
6.3.9	NsLevel information element	28
6.3.9.1	Description	28
6.3.9.2	Attributes.....	28
6.3.10	Void	29
6.3.11	NsProfile information element.....	29
6.3.11.1	Description	29
6.3.11.2	Attributes.....	29
6.3.12	Dependencies information element.....	30
6.3.12.1	Description	30
6.3.12.2	Attributes.....	31
6.3.13	VirtualLinkProtocolData information element	31
6.3.13.1	Description	31
6.3.13.2	Attributes.....	31
6.3.14	L2ProtocolData information element.....	32
6.3.14.1	Description	32
6.3.14.2	Attributes.....	32
6.3.15	L3ProtocolData information element.....	32
6.3.15.1	Description	32
6.3.15.2	Attributes.....	32
6.3.16	VnfScaleInfo information element	33
6.3.16.1	Description	33
6.3.16.2	Attributes.....	33
6.4	Information elements related to the VNF Forwarding Graph Descriptor.....	33
6.4.1	Introduction.....	33
6.4.2	Vnffgd information element	33
6.4.2.1	Description	33
6.4.2.2	Attributes.....	34
6.4.3	Nfspd information element.....	34
6.4.3.1	Description	34

6.4.3.2	Attributes.....	34
6.4.4	Void	35
6.4.5	NfpPositionDesc information element.....	35
6.4.5.1	Description	35
6.4.5.2	Attributes.....	35
6.4.6	NfpPositionElement information element	35
6.4.6.1	Description	35
6.4.6.2	Attributes.....	36
6.4.7	ConstituentProfileElements information element - DEPRECATED	36
6.4.7.1	Description	36
6.4.7.2	Attributes.....	36
6.4.8	CpdInConstituentElement information element	36
6.4.8.1	Description	36
6.4.8.2	Attributes.....	36
6.5	Information elements related to the Network Service Virtual Link Descriptor.....	37
6.5.1	Introduction.....	37
6.5.2	NsVirtualLinkDesc information element.....	37
6.5.2.1	Description	37
6.5.2.2	Attributes.....	37
6.5.3	ConnectivityType information element	37
6.5.3.1	Description	37
6.5.3.2	Attributes.....	37
6.5.4	VirtualLinkDf information element.....	38
6.5.4.1	Description	38
6.5.4.2	Attributes.....	38
6.5.5	LinkBitrateRequirements information element.....	38
6.5.5.1	Description	38
6.5.5.2	Attributes.....	38
6.5.6	NsQoS information element	39
6.5.6.1	Description	39
6.5.6.2	Attributes.....	39
6.6	Information elements related to the PNFD.....	39
6.6.1	Introduction.....	39
6.6.2	Pnfd information element	39
6.6.2.1	Description	39
6.6.2.2	Attributes.....	39
6.6.3	Cpd information element	40
6.6.3.1	Description	40
6.6.3.2	Attributes.....	40
6.6.4	PnfExtCpd information element	40
6.6.4.1	Description	40
6.6.4.2	Attributes.....	41
6.7	Information elements related to scaling.....	41
6.7.1	Introduction.....	41
6.7.2	NsScalingAspect information element.....	41
6.7.2.1	Description	41
6.7.2.2	Attributes.....	41
6.7.3	Void	41
6.7.4	VnfToLevelMapping information element.....	41
6.7.4.1	Description	41
6.7.4.2	Attributes.....	41
6.7.5	VirtualLinkToLevelMapping information element	42
6.7.5.1	Description	42
6.7.5.2	Attributes.....	42
6.7.6	NsToLevelMapping information element.....	42
6.7.6.1	Description	42
6.7.6.2	Attributes.....	43
Annex A (informative): Support of service function chaining.....		44
A.1	Introduction	44
A.2	IETF SFC concepts	44

A.3	Use of the NFP Management interface	46
A.4	Mapping	46
Annex B (informative):	Example of L2_NETWORK scope used in AffinityOrAntiAffinityGroup	48
B.1	Introduction	48
B.2	Use case: AffinityOrAntiAffinityGroup defined in NsVirtualLinkConnectivity	48
B.2.1	Network topology	48
B.2.2	NSD representation	49
B.2.3	NS instantiation	49
Annex C (informative):	Change History	50
History		52

Intellectual Property Rights

Essential patents

IPRs essential or potentially essential to normative deliverables may have been declared to ETSI. The declarations pertaining to these essential IPRs, if any, are publicly available for **ETSI members and non-members**, and can be found in ETSI SR 000 314: "*Intellectual Property Rights (IPRs); Essential, or potentially Essential, IPRs notified to ETSI in respect of ETSI standards*", which is available from the ETSI Secretariat. Latest updates are available on the ETSI Web server (<https://ipr.etsi.org/>).

Pursuant to the ETSI Directives including the ETSI IPR Policy, no investigation regarding the essentiality of IPRs, including IPR searches, has been carried out by ETSI. No guarantee can be given as to the existence of other IPRs not referenced in ETSI SR 000 314 (or the updates on the ETSI Web server) which are, or may be, or may become, essential to the present document.

Trademarks

The present document may include trademarks and/or tradenames which are asserted and/or registered by their owners. ETSI claims no ownership of these except for any which are indicated as being the property of ETSI, and conveys no right to use or reproduce any trademark and/or tradename. Mention of those trademarks in the present document does not constitute an endorsement by ETSI of products, services or organizations associated with those trademarks.

DECT™, **PLUGTESTS™**, **UMTS™** and the ETSI logo are trademarks of ETSI registered for the benefit of its Members. **3GPP™** and **LTE™** are trademarks of ETSI registered for the benefit of its Members and of the 3GPP Organizational Partners. **oneM2M™** logo is a trademark of ETSI registered for the benefit of its Members and of the oneM2M Partners. **GSM®** and the GSM logo are trademarks registered and owned by the GSM Association.

Foreword

This Group Specification (GS) has been produced by ETSI Industry Specification Group (ISG) Network Functions Virtualisation (NFV).

Modal verbs terminology

In the present document "**shall**", "**shall not**", "**should**", "**should not**", "**may**", "**need not**", "**will**", "**will not**", "**can**" and "**cannot**" are to be interpreted as described in clause 3.2 of the [ETSI Drafting Rules](#) (Verbal forms for the expression of provisions).

"**must**" and "**must not**" are **NOT** allowed in ETSI deliverables except when used in direct citation.

1 Scope

The present document specifies requirements and templates for describing Network Functions Virtualisation (NFV) Network Services (NSs) in the form of meta-data.

2 References

2.1 Normative references

References are either specific (identified by date of publication and/or edition number or version number) or non-specific. For specific references, only the cited version applies. For non-specific references, the latest version of the referenced document (including any amendments) applies.

Referenced documents which are not found to be publicly available in the expected location might be found at <https://docbox.etsi.org/Reference/>.

NOTE: While any hyperlinks included in this clause were valid at the time of publication, ETSI cannot guarantee their long term validity.

The following referenced documents are necessary for the application of the present document.

- [1] ETSI GS NFV 003: "Network Functions Virtualisation (NFV); Terminology for Main Concepts in NFV".
- [2] ETSI GS NFV-IFA 011: "Network Functions Virtualisation (NFV); Release 4; Management and Orchestration; VNF Descriptor and Packaging Specification".

2.2 Informative references

References are either specific (identified by date of publication and/or edition number or version number) or non-specific. For specific references, only the cited version applies. For non-specific references, the latest version of the referenced document (including any amendments) applies.

NOTE: While any hyperlinks included in this clause were valid at the time of publication, ETSI cannot guarantee their long term validity.

The following referenced documents are not necessary for the application of the present document but they assist the user with regard to a particular subject area.

- [i.1] ETSI GS NFV 002: "Network Functions Virtualisation (NFV); Architectural Framework".
- [i.2] ETSI GS NFV-IFA 013: "Network Functions Virtualisation (NFV); Release 4; Management and Orchestration; Os-Ma-Nfvo reference point - Interface and Information Model Specification".
- [i.3] ETSI GS NFV-SWA 001: "Network Functions Virtualisation (NFV); Virtual Network Functions Architecture".
- [i.4] ISO/IEC 9646-7: "Information technology -- Open Systems Interconnection -- Conformance testing methodology and framework -- Part 7: Implementation Conformance Statements".
- [i.5] Void.
- [i.6] IETF RFC 7665: "Service Function Chaining (SFC) Architecture".
- [i.7] ETSI GS NFV-IFA 005: "Network Functions Virtualisation (NFV); Release 4; Management and Orchestration; Or-Vi reference point - Interface and Information Model Specification".
- [i.8] IETF RFC 4090: "Fast Reroute Extensions to RSVP-TE for LSP Tunnels".

[i.9] ETSI GS NFV-IFA 014 (V3.3.1): "Network Functions Virtualisation (NFV) Release 3; Management and Orchestration; Network Service Templates Specification".

3 Definition of terms, symbols and abbreviations

3.1 Terms

For the purposes of the present document, the terms given in ETSI GS NFV 003 [1] and the following apply:

Service Access Point (SAP): connection point where an NS can be accessed

NOTE: A SAP can either provide access to an NS, e.g. to an end-user, or interconnect different NS.

3.2 Symbols

Void.

3.3 Abbreviations

For the purposes of the present document, the abbreviations given in ETSI GS NFV 003 [1] and the following apply:

CDN	Content Delivery Network
CM	Conditional Mandatory
CO	Conditional Optional
CP	Connection Point
CPD	Connection Point Descriptor
DF	Deployment Flavour
DSL	Domain Specific Language
E-LAN	Ethernet Local Area Network
GS	Group Specification
IPV4	Internet Protocol Version 4
IPV6	Internet Protocol Version 6
LAN	Local Area Network
LSP	Label-Switched Path
MANO	Management and Orchestration
MPLS	MultiProtocol Label Switching
NCT	Network Connectivity Topology
NFP	Network Forwarding Path
NFPD	Network Forwarding Path Descriptor
NS	Network Service
NSD	Network Service Descriptor
ODU2	Optical channel Data Unit - type 2
PM	Performance Management
PNFD	Physical Network Function Descriptor
RSVP-TE	Resource Reservation Protocol Traffic Engineering
SAL	Service Availability Level
SAP	Service Access Point
SAPD	Service Access Point Descriptor
SFC	Service Function Chaining
TE	Traffic Engineering
UML	Unified Modelling Language
VL	Virtual Link
VLD	Virtual Link Descriptor
VNFFG	VNF Forwarding Graph
VNFFGD	VNF Forwarding Graph Descriptor
XOR	eXclusive OR

4 Overview

4.1 Network Service Descriptions

The Network Service Descriptor (NSD) is a deployment template which consists of information used by the NFV Orchestrator (NFVO) for life cycle management of an NS.

An NS is a composition of Network Functions (NFs) arranged as a set of functions with unspecified connectivity between them or according to one or more forwarding graphs. As illustrated in figure 4.1-1, the description of an NS as used by the NFV Management and Orchestration (MANO) functions to deploy an NS instance includes or references the descriptors of its constituent objects:

- Zero, one or more Virtualised Network Function Descriptors (VNFD);
- Zero, one or more Physical Network Function Descriptor (PNFD) used by the NFVO to determine how to connect PNFs to VLs;
- Zero, one or more nested NSD;

NOTE 1: The information contained within the PNFD is limited to the description of the connectivity requirements to integrate PNFs in an NS.

NOTE 2: An NSD references at least either one VNFD or one nested NSD.

- Zero, one or more Virtual Link Descriptor (VLD) used by the NFVO to deploy Virtual Links (VL); and
- Zero, one or more VNF Forwarding Graph Descriptor (VNFFGD).

A VNF Forwarding Graph Descriptor (VNFFGD) describes a topology of the NS or a portion of the NS, by referencing a pool of connection points and service access points, the descriptors of its constituent VNFs, PNFs and of the VLs that connect them. It may also contain one or more Network Forwarding Path (NFP) descriptors.

NOTE 3: Different VNFFGDs can be contained in a given NSD. Each VNFFGD uses subsets of the lists of VLDs, VNFDs and PNFDs included in the NSD.

NOTE 4: For a given NS different VNFFGDs can result in packets/frames traversing identical sequences of (V)NFs, depending on the NFP descriptors included in the VNFFGDs.

NOTE 5: In a given VNFFGD the connectivity topology represents how the (V)NFs among which packets/frames can be exchanged are connected to each other. A Network Connectivity Topology (NCT), as defined in ETSI GS NFV-SWA 001 [i.3] represents a higher logical level connectivity, possibly a global view of combined connectivity from different VNFFGDs of a given NS.

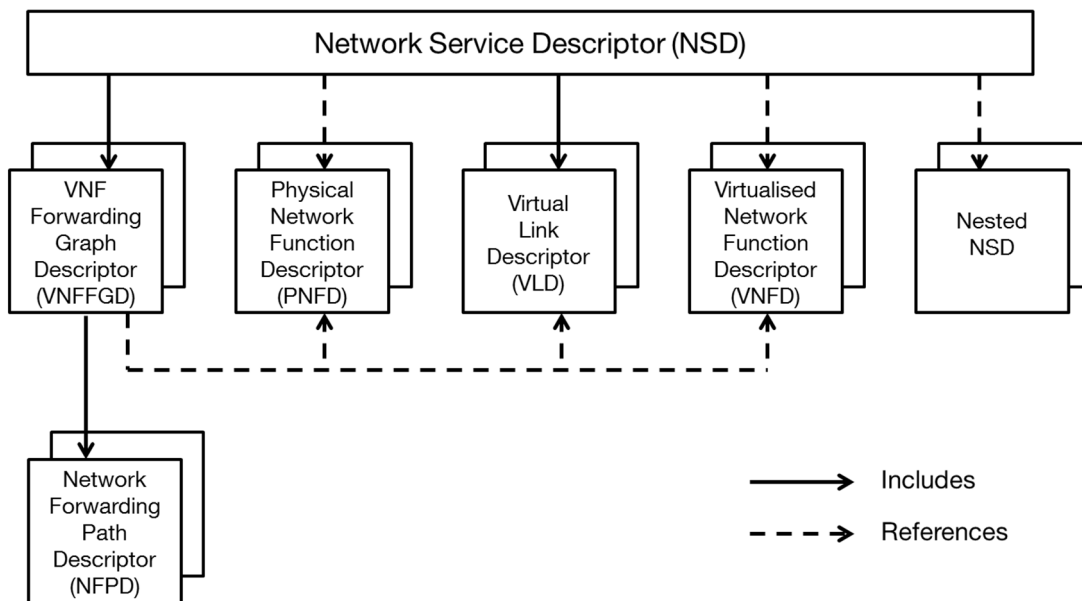

Figure 4.1-1: NSD overview

4.2 Relation to other ETSI NFV Group Specifications

The concepts of network services and forwarding graphs are described in ETSI GS NFV 002 [i.1].

Instances of objects created according to the templates specified in the present document are exchanged at the Os-Ma-Nfvo reference point as specified in ETSI GS NFV-IFA 013 [i.2].

The format of the VNF descriptors referenced in a network service template shall comply with the specifications in ETSI GS NFV-IFA 011 [2].

4.3 Conventions

The attributes of the NSD and associated information elements are described in the tables provided in clause 6. Each table has 5 columns, with the following significance:

- The "Attribute" column provides the attribute name.
- The "Qualifier" column indicates whether the support of the attribute is mandatory, optional or conditional.
- The "Cardinality" column contains the minimum and maximum cardinality of this information element (e.g. 1, 2, 0..N, 1..N). A cardinality range starting with 0 indicates that the attribute needs not always to be included.
- The "Content" column provides information on the type of the attribute values. It can be the name of an Information Element, a primitive type (Identifier, DateTime, etc.) or a generic UML type (String, Integer, etc.). If a cell in the "Content" column is marked as "Not specified", this means that the specification of the type is part of the data model design.
- The "Description column" provides a brief explanatory description and additional constraints.

The following notations, defined in ISO/IEC 9646-7 [i.4], are used for the qualifier column of information elements:

- M mandatory - the attribute shall be supported.
- O optional - the attribute may, but need not, be supported.
- CM conditional mandatory - the attribute shall be supported under certain conditions. If the specified conditions are met then the attribute shall be supported. These conditions are specified in the Description column.

- CO conditional optional - the attribute may, but need not, be supported under certain conditions. If the specified conditions are met then the attribute may, but need not, be supported. These conditions are specified in the Description column.

The following notation is used for parameters that represent identifiers, and for attributes that represent identifiers in information elements and notifications:

- If parameters are referring to an identifier of an actual object, their type is "Identifier".
- If an object (information element or notification) contains an attribute that identifies the object, the type of that attribute is "Identifier" and the description states that the attribute is the identifier of that particular notification or information element.

EXAMPLE 1: Identifier "resourceId" of the "NetworkSubnet information element" has type "Identifier" and description "Identifier of this NetworkSubnet information element".

- If an object (information element or notification) contains an attribute that references another object or objects defined in an ETSI NFV Group Specification (GS), the type of the attribute is "Identifier", followed by the list of objects it references.

EXAMPLE 2: "Identifier (Reference to Vnfc)" or "Identifier (Reference to Vnfc, VirtualLink or VirtualStorage)".

4.4 Various levels of NFV entities

For NFV management and orchestration, there are four basic levels of entities:

- Descriptors - general type definitions for things such as NSs, VNFs and VLs.
- Descriptor objects - an instance of a descriptor, e.g. an instance of an NSD (not an instance of an NS instantiated according to this NSD):
 - A descriptor object may provide (among other things) value ranges and default values for the attributes in the associated NFV entity class.
 - In the present document, the creation of subclasses of generic descriptors (e.g. NSD_x as a subclass of NSD) has been avoided, since this approach would create a proliferation of descriptor classes.
- NFV entity classes - these are classes that represent various NFV entities such as NS, VNF and VL. There is one-to-one mapping between the set of descriptor objects and the set of NFV entity classes. An example of NFV entity class is CDN NS.
- NFV entity instances - these are instances of a given NFV entity class. An NFV entity instance is used to represent the current state and attribute values for a given NFV entity. Each NFV entity instance is bound by the associated descriptor object, e.g. value ranges and default values for attributes. More than one NFV entity instance can be created from the same associated descriptor object. An example of NFV entity instance is CDN NS instance.

Each level puts constraints on the subsequent levels.

Information in a lower level does not appear in a higher level, e.g. NFV entity instance information does not appear in the associated NFV entity class, descriptor object or descriptor.

5 Functional requirements

5.1 Void

5.2 Functional requirements for Network Service Descriptor

Table 5.2-1 specifies functional requirements applicable to the templates for NSD instances.

Table 5.2-1: Functional requirements for NSD

Numbering	Requirement description
NST_NSDD001	The NSD shall reference the VNFDs applicable to its constituent VNFs.
NST_NSDD002	The NSD shall include the VLDs applicable to the VLs used by the NS to interconnect its constituent VNFs.
NST_NSDD003	The NSD shall reference the PNFDs applicable to its constituent PNFs.
NST_NSDD004	The NSD shall specify the Service Access Points (SAPs) of the NS.
NST_NSDD005	The NSD shall include the descriptors of the VNFFGs applicable to the NS. See note 1.
NST_NSDD006	The NSD shall support the capability to include or reference NS life cycle management scripts describing how to react upon specific life cycle events, fault detection, performance threshold crossing detection and other events that can occur at the NFVO reference points.
NST_NSDD007	The NSD shall support the capability to provide monitoring parameters to be tracked during the lifetime of an NS instance. See note 2.
NST_NSDD008	The NSD shall support the capability to describe one or more NS DF(s).
NST_NSDD009	The NSD shall support the capability to describe auto scale rules, associating criteria to scaling actions (e.g. removing existing VNF instances from an NS instance).
NST_NSDD010	The NSD shall include security information enabling validating its authenticity and integrity.
NST_NSDD011	The NSD shall support the capability to reference NSDs used to instantiate nested or appended NSs. See note 3.
NST_NSDD012	The NSD shall include a globally unique identifier for identifying each descriptor instance.
<p>NOTE 1: An NS might have multiple graphs, for example, for:</p> <ol style="list-style-type: none"> 1) Control plane traffic. 2) Management plane traffic. 3) User plane traffic. <p>NOTE 2: These can be used for specifying different Deployment Flavours (DF) for the NS in the NSD or in determining the need to scale-out.</p> <p>NOTE 3: NSs are composable, i.e. they can include other NSs (a.k.a. nested NS) or other NSs can be appended to them.</p>	

5.3 Functional requirements for Network Service Deployment Flavour

Table 5.3-1 specifies functional requirements applicable to the templates for describing NS DF.

Table 5.3-1: Functional requirements for NS DF description

Numbering	Requirement description
NST_NSDF001	An NS DF description shall describe how many instances of each constituent VNF are required.
NST_NSDF002	An NS DF description shall reference a VNF flavour to be used for each constituent VNF.
NST_NSDF003	An NS DF description shall enable describing affinity and anti-affinity rules between the different instances of a constituent VNF.
NST_NSDF004	An NS DF description shall enable describing affinity and anti-affinity rules between the constituent VNFs.
NST_NSDF005	An NS DF description shall enable referencing a VL flavour to be used for each VL connected to its constituent VNFs.
NST_NSDF006	An NS DF description shall enable describing affinity and anti-affinity rules between the different instances of a constituent VL. See note 1.
NST_NSDF007	An NS DF description shall enable describing affinity and anti-affinity rules between the constituent VLs. See note 1.
NST_NSDF008	An NS DF description shall support the capability to describe dependencies between VNF and/or nested NS instances in terms of primary and secondary entities. See note 2.
NST_NSDF009	An NS DF description shall support the capability to describe a priority for the NS instance. See note 3.
NST_NSDF010	An NS DF description shall support the capability to describe the service availability level for the NS instance. See note 4.
<p>NOTE 1: The rules need to consider that constituent VL(s) can be instantiated within an NFVI-PoP or across a WAN.</p> <p>NOTE 2: This information is used, for example, to define the sequence in which various numbered VNF and/or nested NS should be instantiated by the NFVO.</p> <p>NOTE 3: This information is used for example during resource allocation to resolve conflicts during resource shortage.</p> <p>NOTE 4: This information is used for applicable NS/VNF LCM related operations, for example during resource allocation to assist in the selection of virtualised resources with appropriate resiliency characteristics.</p>	

5.4 Functional requirements for VNF Forwarding Graph Descriptor

Table 5.4-1 specifies functional requirements applicable to a VNFFGD.

Table 5.4-1: Functional requirements for VNFFGD

Numbering	Requirement description
NST_FGD001	A VNFFGD shall enable associating multiple network forwarding paths to a forwarding graph.
NST_FGD002	Within a VNFFGD, an NFP description shall enable associating a set of conditions captured in a rule to a sequence of connection points to be traversed by packets or frames matching these conditions. See note.
NST_FGD003	A VNFFGD shall reference the VNFDs and PNFDs of its constituent VNFs and PNFs.
NST_FGD004	A VNFFGD shall reference the VLDs applicable to instantiate VLs between the VNFs and PNFs that are part of the VNFFGD.
NST_FGD005	A VNFFGD shall enable referencing a pool of descriptors of connection points attached to constituent VNFs and PNFs and/or of SAPs of the parent NS or of a nested NS.
NOTE:	Annex A provides an overview of the mapping between NFV terminology and the IETF terminology for Service Function Chaining (SFC) and NFP management.

5.5 Functional requirements for Virtual Link Descriptor

Table 5.5-1 specifies functional requirements applicable to a VLD.

Table 5.5-1: Functional requirements for VLD

Numbering	Requirement description
NST_VLD001	A VLD shall enable specifying the type of connectivity provided by the link (e.g. Layer 2 E-Line, E-LAN or E-Tree, or Layer 3).
NST_VLD002	A VLD shall enable specifying one or more VL DFs. See note.
NOTE:	Different VL DFs may be used for different flavours of the same NS.

Table 5.5-2 specifies functional requirements for VL DF descriptions.

Table 5.5-2: Functional requirements for VL DF description

Numbering	Requirement description
NST_VLDF001	A VL DF description shall enable specifying requirements on performance characteristics of the link for inter-VNF communication as well as communication with external entities and PNFs (e.g. round trip delay, jitter, packet loss ratio, etc.).
NST_VLDF002	A VL DF description shall enable specifying requirements on the throughput of the link (e.g. bandwidth of E-Line, root bandwidth of E-Tree, and aggregate capacity of E-LAN).
NST_VLDF003	A VL DF description shall enable specifying the throughput of leaf connections to the link (e.g. for E-Tree and E-LAN branches), where applicable for the connectivity topology being used.
NST_VLDF004	A VL DF description shall enable specifying service availability levels.

5.6 Functional requirements for Physical Network Function Descriptor

Table 5.6-1 specifies functional requirements applicable to a PNFD.

Table 5.6-1: Functional requirements for PNFD

Numbering	Requirement description
NST_PNFD001	A PNFD shall enable specifying the characteristics of the connection points exposed by a PNF.

5.7 Functional requirements for PNFD archive

Table 5.7-1 specifies functional requirements applicable to the structure of a PNFD archive.

Table 5.7-1: Functional requirements for the structure of a PNFD archive

Numbering	Requirement description
NST_PNFDA001	The PNFD contents shall be assembled as one single file, the PNFD archive.
NST_PNFDA002	The PNFD archive contents, including the PNF descriptor as well as manifest file, checksum, etc. constitutes a single delivery unit from a distribution perspective. Any changes to the constituency of this unit shall be considered as a change to the whole and therefore shall be versioned, tracked and inventoried as one.
NST_PNFDA003	The PNFD archive shall contain a change log. The change log captures the changes from one version to another.
NST_PNFDA004	The PNFD archive shall allow to store in the archive sets of related artifacts for use by functional blocks beyond NFV-MANO, and to assign a globally unique identifier to each set in an SDO-independent and vendor-independent manner.
NST_PNFDA005	The PNFD archive and each of its constituents shall be digitally signed by the creator of the PNFD archive or the creator of the specific constituent respectively. See note.
NST_PNFDA006	The digest and the public key of the entity signing the PNFD archive shall be included in the archive along with the corresponding certificate.
NST_PNFDA007	For each signed artifact, corresponding public key, algorithm and certificate used shall be stored in a well-known location within the PNFD archive.
NST_PNFDA008	Security sensitive artifacts shall be encrypted. Encryption keys for these artifacts should be different than the PNFD archive key to allow for better access control within the provider environment.
NOTE:	The present document does not make any assumption on which organization or entity creates the PNFD archive.

6 Descriptors formats and contents

6.1 Void

6.2 Information elements related to the Network Service Descriptor

6.2.1 Introduction

Clauses 6.2.2 to 6.2.9.2 define the information elements related to the NSD.

The UML information diagram of the NSD is provided in figure 6.2.1-1.

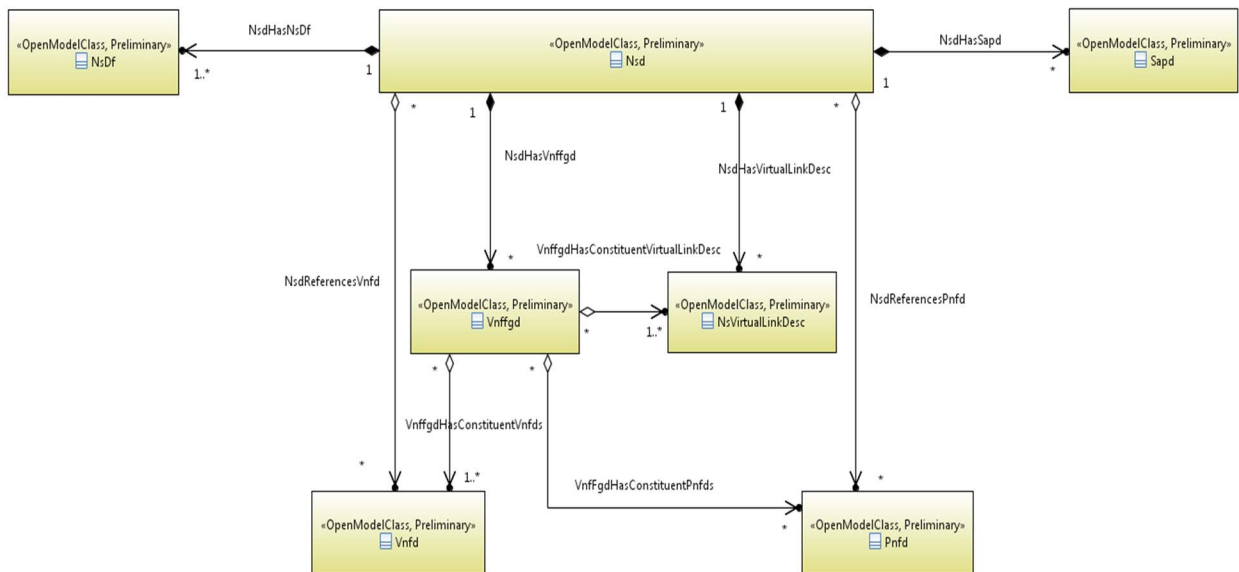

Figure 6.2.1-1: UML information diagram of NSD

6.2.2 Network Service Descriptor information element

6.2.2.1 Description

The NSD information element is a deployment template whose instances are used by the NFVO for the lifecycle management of NSs.

6.2.2.2 Attributes

The attributes of the NSD information element shall follow the indications provided in table 6.2.2.2-1.

Table 6.2.2.2-1: Attributes of the NSD information element

Attribute	Qualifier	Cardinality	Content	Description
nsdIdentifier	M	1	Identifier	Identifier of this NSD information element. It Globally uniquely identifies an instance of the NSD.
designer	M	1	String	Specifies the designer of the NSD.
version	M	1	Version	Specifies the version of the NSD.
nsdName	M	1	String	Provides the human readable name of the NSD.
nsdInvariantId	M	1	Identifier	Identifies an NSD in a version independent manner. This attribute is invariant across versions of NSD with no constraint on the changes across versions. See note 5.
nsdExtInvariantId	M	0..1	Identifier	Identifies an NSD in a version independent manner. This attribute is invariant across versions of the NSD that fulfil certain conditions related to the external connectivity and management of the NS. See note 6.
nestedNsdlId	M	0..N	Identifier (Reference to Nsd)	References the NSD of a constituent nested NS. See note 1.

Attribute	Qualifier	Cardinality	Content	Description
vnfdId	M	0..N	Identifier (Reference to Vnfd)	References the VNFD of a constituent VNF. See note 1.
pnfdId	M	0..N	Identifier (Reference to Pnfd)	References the PNFD of a constituent PNF. See note 1.
sapd	M	0..N	Sapd	Provides the descriptor of a service access point of the network service.
virtualLinkDesc	M	0..N	NsVirtualLinkDesc	Provides the constituent VLDs. See note 2.
vnffgd	M	0..N	Vnffgd	Provides the descriptors of the applicable forwarding graphs. See note 2.
autoScalingRule	M	0..N	Rule	Specifies a rule to trigger a scaling action on an NS instantiated according to the NSD. See notes 3 and 4.
lifeCycleManagementScript	M	0..N	LifeCycleManagementScript	Provides a life cycle management script written in a Domain Specific Language (DSL).
nsDf	M	1..N	NsDf	Specifies a DF within the scope of an NSD.
security	M	1	SecurityParameters	Provides a signature to prevent tampering.
<p>NOTE 1: At least one between nestedNsd and vnfdId attributes shall be present.</p> <p>NOTE 2: Cardinality of 0 means that the NS is a NF set with unspecified connectivity.</p> <p>NOTE 3: The rule is based on a combination of assertions on the values of virtualised resource-related performance metrics and VNF Indicators identified by the monitoredInfo attribute of the NsDf from which the NS instance is created.</p> <p>NOTE 4: There may be multiple data sources per rule, each corresponding to a different monitoredInfo attribute occurrence of the NsDf from which the NS instance is created.</p> <p>NOTE 5: The association of an NSD to an existing NS instance can be changed upon the condition that both NSDs have the same nsdInvariantId.</p> <p>NOTE 6: Different versions of an NSD have different nsdIds but can have the same nsdExtInvariantId. Different versions of the NSD with the same nsdExtInvariantId shall expose:</p> <ul style="list-style-type: none"> • same external connectivity, i.e. same number of SAPDs and same identifiers; • same NSD attributes used in a composite NSD when referring to this NSD as nested NS: <ul style="list-style-type: none"> ○ NS deployment flavours and NS instantiation levels: in both cases the identifiers and the number of them shall be the same, but the content of e.g. a particular deployment flavour can change. ○ NsScaleInfo: same NsScalingAspects identifiers and same NsLevels identifiers per NsScalingAspect. <p>This condition implies that NSDs with the same nsdExtInvariantId preserve external invariancy. Therefore, fulfilling this condition allows to use a different version of a nested NSD in a composite NS instance without modification of the NSD on which the composite NS instance is based. The use of a different version of the nested NSD is ultimately under the control of the service provider of the composite NS and it should consider if the composite NSD fulfils the requirements of the SAPDs of the nested NSD (e.g. bitrate, IP version, etc.).</p>				

6.2.3 Sapd information element

6.2.3.1 Description

The Sapd information element specifies the information used to instantiate the service access points of an NS. A Sapd inherits from the corresponding Cpd Class (see clause 6.6.3). All attributes of the Cpd are also attributes of the Sapd.

6.2.3.2 Attributes

The attributes of the Sapd information element shall follow the indications provided in table 6.2.3.2-1.

Table 6.2.3.2-1: Attributes of the Sapd information element

Attribute	Qualifier	Cardinality	Content	Description
nsVirtualLinkDescId	M	0..1	Identifier (Reference to NsVirtualLinkDesc)	References the descriptor of the NS VL instance to which the SAP instantiated from this SAPD connects to. See note.
associatedCpd	M	0..1	CpdInConstituentElement	Describes CPD or SAPD in the context of an NS constituent element, which the SAPs instantiated from this SAPD are mapped to. See note.
(inherited attributes)				All attributes inherited from corresponding Cpd.

NOTE: At most one of the two attributes associatedCpd and nsVirtualLinkDescId shall be included.

6.2.4 Void

6.2.5 SecurityParameters information element

6.2.5.1 Description

The SecurityParameters information element contains the signature of an NSD instance together with information required to validate the signature.

6.2.5.2 Attributes

The attributes of the SecurityParameters information element shall follow the indications provided in table 6.2.5.2-1.

Table 6.2.5.2-1: Attributes of the SecurityParameters information element

Attribute	Qualifier	Cardinality	Content	Description
signature	M	1	String	Provides the signature of the signed part of the descriptor.
algorithm	M	1	String	Specifies the algorithm used to compute the signature.
certificate	M	0..1	Not specified	Provides a certificate or a reference to a certificate to validate the signature. See note.

NOTE: Cardinality of 0 corresponds to the case where the certificate is provided by means outside the NSD.

6.2.6 MonitoredData information element

6.2.6.1 Description

The MonitoredData information element identifies information to be monitored during the lifetime of a network service instance.

6.2.6.2 Attributes

The attributes of the MonitoredData information element shall follow the indications provided in table 6.2.6.2-1.

Table 6.2.6.2-1: Attributes of the MonitoredData information element

Attribute	Qualifier	Cardinality	Content	Description
vnfIndicatorInfo	M	0..1	VnfIndicatorData	Provides information on a VNF Indicator to be monitored. See note.
monitoringParameter	M	0..1	MonitoringParameter	Specifies the virtualised resource related performance metric to be monitored on an NS level or VNF level. See note.

NOTE: One and only one of the attributes shall be included (i.e. there is a XOR relationship between the attributes).

6.2.7 VnfIndicatorData information element

6.2.7.1 Description

The VnfIndicatorData information element identifies a VNF indicator in a VNFD.

6.2.7.2 Attributes

The attributes of the VnfIndicatorData information element shall follow the indications provided in table 6.2.7.2-1.

Table 6.2.7.2-1: Attributes of the VnfIndicatorData information element

Attribute	Qualifier	Cardinality	Content	Description
vnfdId	M	1	Identifier (Reference to Vnfd)	References a VNFD.
vnfIndicator	M	1	Identifier (Reference to VnfIndicator)	References a VNF indicator within the VNFD.

6.2.8 MonitoringParameter information element

6.2.8.1 Description

The MonitoringParameter information element specifies a virtualised resource related performance metric to be monitored.

6.2.8.2 Attributes

The attributes of the MonitoringParameter information element shall follow the indications provided in table 6.2.8.2-1.

Table 6.2.8.2-1: Attributes of the MonitoringParameter information element

Attribute	Qualifier	Cardinality	Content	Description
monitoringParameterId	M	1	Identifier	Unique identifier of this monitoring parameter information element.
name	M	0..1	String	Human readable name of the monitoring parameter.
performanceMetric	M	1	String	Defines the virtualised resource-related performance metric. See note.
collectionPeriod	M	0..1	Not specified	An attribute that describes the periodicity at which to collect the performance information.

NOTE: The NFVO collects the performance reports corresponding to metric defined in this attribute from the VIMs and VNFMs using one or more PM Jobs.

6.2.9 LifeCycleManagementScript information element

6.2.9.1 Description

The LifeCycleManagementScript information element specifies a script for the NS.

6.2.9.2 Attributes

The attributes of the LifeCycleManagementScript information element shall follow the indications provided in table 6.2.9.2-1.

Table 6.2.9.2-1: Attributes of the LifeCycleManagementScript information element

Attribute	Qualifier	Cardinality	Content	Description
event	M	1..N	String	Describes NS lifecycle event(s) or an external stimulus detected on an NFVO reference point. See notes 1 and 2.
script	M	1	Not specified	Includes an NS LCM script (e.g. written in a DSL) triggered to react to one of the events listed in the event attribute.
NOTE 1: A minimum set of NS lifecycle events triggered internally by the NFVO includes: start instantiation, end instantiation, start scaling, end scaling, start healing, end healing, start termination, end termination, start update, end update.				
NOTE 2: A minimum set of external stimulus includes: the receipt of request message of instantiation, scaling, healing, termination, update of NS.				

6.2.10 Information elements related to NS lifecycle management operations

6.2.10.1 Introduction

This clause defines information elements which represent additional parameters for lifecycle management operations of NS, as specified in ETSI GS NFV-IFA 013 [i.2].

6.2.10.2 NsLcmAdditionalParams information element

6.2.10.2.1 Description

This information element is a container for all additional parameters that affect the invocation of NS Lifecycle Management operations, structured by operation.

6.2.10.2.2 Attributes

The attributes of NsLcmAdditionalParams information element shall follow the indications provided in table 6.2.10.2.2-1.

Table 6.2.10.2.2-1: Attributes of NsLcmAdditionalParams information element

Attribute	Qualifier	Cardinality	Content	Description
instantiateNsAdditionalParams	M	0..1	InstantiateNsAdditionalParams	Additional parameters for the Instantiate NS operation
scaleNsAdditionalParams	M	0..1	ScaleNsAdditionalParams	Additional parameters for the Scale NS operation
healNSAdditionalParams	M	0..1	HealNsAdditionalParams	Additional parameters for the Heal NS operation

6.2.10.3 InstantiateNsAdditionalParams information element

6.2.10.3.1 Description

This information element defines attributes that represent additional parameters for invocation of the Instantiate Ns operation.

6.2.10.3.2 Attributes

The attributes of InstantiateNsAdditionalParams information element shall follow the indications provided in table 6.2.10.3.2-1.

Table 6.2.10.3.2-1: Attributes of InstantiateNsAdditionalParams information element

Attribute	Qualifier	Cardinality	Content	Description
nsAdditionalParam	M	0..N	Not specified	Array of KVP requirements for additional parameters of NS to be passed when invoking the Instantiate Ns operation. See note.
NOTE: It is assumed that the KVP requirements will be implicitly used to define the value type.				

6.2.10.4 ScaleNsAdditionalParams information element

6.2.10.4.1 Description

This information element defines attributes that represent additional parameters for invocation of the Scale Ns operation.

6.2.10.4.2 Attributes

The attributes of the ScaleNsAdditionalParams information element shall follow the indications provided in table 6.2.10.4.2-1.

Table 6.2.10.4.2-1: Attributes of ScaleNsAdditionalParams information element

Attribute	Qualifier	Cardinality	Content	Description
nsAdditionalParam	M	0..N	Not specified	Array of KVP requirements for additional parameters of NS to be passed when invoking the Scale Ns operation. See note.
NOTE: It is assumed that the KVP requirements will be implicitly used to define the value type.				

6.2.10.5 HealNsAdditionalParams information element

6.2.10.5.1 Description

This information element defines attributes that represent additional parameters for invocation of the Heal Ns operation.

6.2.10.5.2 Attributes

The attributes of the HealNsAdditionalParams information element shall follow the indications provided in table 6.2.10.5.2-1.

Table 6.2.10.5.2-1: Attributes of HealNsAdditionalParams information element

Attribute	Qualifier	Cardinality	Content	Description
nsAdditionalParam	M	0..N	Not specified	Array of KVP requirements for additional parameters of NS when invoking the Heal Ns operation. See note.
NOTE: It is assumed that the KVP requirements will be implicitly used to define the value type.				

6.3 Information elements related to the Network Service Deployment Flavour

6.3.1 Introduction

Clauses 6.3.2 to 6.3.12.2 define the information elements related to the NsDf.

6.3.2 NsDf information element

6.3.2.1 Description

The NsDf information element specifies the properties of a variant of an NS.

6.3.2.2 Attributes

The attributes of the NsDf information element shall follow the indications provided in table 6.3.2.2-1.

Table 6.3.2.2-1: Attributes of the NsDf information element

Attribute	Qualifier	Cardinality	Content	Description
nsDfId	M	1	Identifier	Identifies this NsDf information element. It identifies an NS DF within the NSD.
flavourKey	M	1	String	Assurance parameter against which this flavour is being described. The key can be a combination of multiple assurance parameters with a logical relationship between them. The parameters should be present as a monitoredInfo attribute in this NsDf.
vnfProfile	M	0..N	VnfProfile	VNF profile to be used for the NS flavour.
pnfProfile	M	0..N	PnfProfile	PNF profile to be used for the NS flavour.
virtualLinkProfile	M	0..N	VirtualLinkProfile	VL profile to be used for the NS flavour.
scalingAspect	M	0..N	NsScalingAspect	The scaling aspects supported by this DF of the NS.
affinityOrAntiAffinityGroup	M	0..N	AffinityOrAntiAffinityGroup	Specifies affinity or anti-affinity relationship applicable between the VNF instances created using different VNFDs, the Virtual Link instances created using different NsVirtualLinkDescs or the nested NS instances created using different NSDs in the same affinity or anti-affinity group. See clause 6.3.5.
nsInstantiationLevel	M	1..N	NsLevel	Describes the details of an NS level. See clause 6.3.9. See note 1.

Attribute	Qualifier	Cardinality	Content	Description
defaultNsInstantiationLevelId	M	0..1	Identifier (Reference to NsLevel)	References the NS level which represents the default NS instantiation level for this DF. It shall be present if there are multiple "nsInstantiationLevel" entries.
nsLcmAdditionalParams	M	0..1	NsLcmAdditionalParams	Additional parameters for NS Lifecycle Management operations.
nsProfile	M	0..N	NsProfile	Specifies nested NS Profile to be used for this NS DF.
dependencies	M	0..N	Dependencies	Specifies the order in which instances of the VNFs and/or nested NSs have to be created.
monitoredInfo	M	0..N	MonitoredData	Specifies either a virtualised resource-related performance metric or a VNF Indicator to be monitored.
priority	M	0..1	Integer	Specifies the priority for the NS instance. See notes 2 and 3.
serviceAvailabilityLevel	M	0..1	Integer	If present, specifies the service availability level for the NS instance created from this DF. See note 4.
<p>NOTE 1: Every VNF, VL and nested NS whose descriptor is referenced by the NS DF shall be involved in an NS instantiation level of the parent NS. If no instances of a given VNF/nested NS have to be deployed at NS instantiation time, the numberOfInstances attribute in the corresponding VnfToLevelMapping/NsToLevelMapping information element shall be set to 0.</p> <p>NOTE 2: The allowed range is expected to be defined in the corresponding data model specification and should be reasonably high. The "zero" value expresses the highest priority and the fact that the NS instance based on this DF cannot be pre-empted during resource allocation.</p> <p>NOTE 3: Examples for the usage of priority include conflict resolution in case of resource shortage.</p> <p>NOTE 4: Either the serviceAvailabilityLevel attribute of NS DF or the serviceAvailabilityLevel attribute of the NS constituents of the NS may be provided, but not both. When a SAL information is assigned to an NS, this information does not apply to any constituents of type 'nested NS'.</p>				

6.3.3 VnfProfile information element

6.3.3.1 Description

The VnfProfile information element specifies a profile for instantiating VNFs of a particular NS DF according to a specific VNFD and VNF DF.

6.3.3.2 Attributes

The attributes of the VnfProfile information element shall follow the indications provided in table 6.3.3.2-1.

Table 6.3.3.2-1: Attributes of the VnfProfile information element

Attribute	Qualifier	Cardinality	Content	Description
vnfProfileId	M	1	Identifier	Identifier of this VnfProfile information element. It uniquely identifies a VnfProfile.
vnfdId	M	1	Identifier (Reference to Vnfd)	References a VNFD.

Attribute	Qualifier	Cardinality	Content	Description
vnfdExtInvariantId	M	0..1	Identifier	Identifies a VNFD in a version independent manner. If present it shall have the same value as the vnfdExtInvariantId in the VNFD referenced by the vnfdId attribute. It allows for VNF instances during NS LCM the use of a VNFD different from the one referenced by the vnfdId attribute, provided they have the same vnfdExtInvariantId. See note 5.
flavourId	M	1	Identifier (Reference to VnfDf)	References a flavour within the VNFD. See note 1.
instantiationLevel	M	0..1	Identifier	Identifier of the instantiation level of the VNF DF to be used for instantiation. See note 4.
targetVnfScaleLevelInfo	M	0..N	VnfScaleInfo	This attribute is applicable if VNF supports target scale level instantiation. For each scaling aspect of the current VNF deployment flavour, the attribute specifies the scale level of VNF constituents (e.g. VDU level) to be instantiated. See note 4.
minNumberOfInstances	M	1	Integer	Minimum number of instances of the VNF based on this VNFD that is permitted to exist for this VnfProfile.
maxNumberOfInstances	M	1	Integer	Maximum number of instances of the VNF based on this VNFD that is permitted to exist for this VnfProfile.
localAffinityOrAntiAffinityRule	M	0..N	LocalAffinityOrAntiAffinityRule	Specifies affinity and anti-affinity rules applicable between VNF instances created from this profile. See clause 6.3.8.
affinityOrAntiAffinityGroupId	M	0..N	Identifier (Reference to AffinityOrAntiAffinityGroup)	Reference(s) the affinity or anti-affinity group(s) the VnfProfile belongs to. See note 2.
nsVirtualLinkConnectivity	M	1..N	NsVirtualLinkConnectivity	Defines the connection information of the VNF, it contains connection relationship between a VNF connection point and an NS Virtual Link.
serviceAvailabilityLevel	M	0..1	Integer	If present, specifies the service availability level for the VNF instance created from this profile. See note 3.

NOTE 1: The VnfDf information element is defined in ETSI GS NFV-IFA 011 [2], clause 7.1.8.2.

NOTE 2: Each identifier references an affinity or anti-affinity group which expresses affinity or anti-affinity relationships between the VNF instance(s) created using this VnfProfile and the VNF instance(s) created using other VnfProfile(s) in the same group.

NOTE 3: Either the serviceAvailabilityLevel attribute of NS DF or the serviceAvailabilityLevel attribute of the VnfProfile may be provided, but not both.

NOTE 4: The target size for VNF instantiation is either expressed as an instantiation level of that deployment flavour as defined in the VNFD, or alternatively as targetVnfScaleLevelInfo, but not both. If none of the two attributes (instantiationLevelId or targetVnfScaleLevelInfo) are present, the default instantiation level as declared in the VNFD shall be used.

NOTE 5: This attribute should be included to avoid changes in the NSD caused by version changes in the VNFD.

6.3.4 VirtualLinkProfile information element

6.3.4.1 Description

The VirtualLinkProfile information element specifies a profile for instantiating VLs of a particular NS DF according to a specific VLD and VL DF.

6.3.4.2 Attributes

The attributes of the VirtualLinkProfile information element shall follow the indications provided in table 6.3.4.2-1.

Table 6.3.4.2-1: Attributes of the VirtualLinkProfile information element

Attribute	Qualifier	Cardinality	Content	Description
virtualLinkProfileId	M	1	Identifier	Uniquely identifies this VirtualLinkProfile information element.
virtualLinkDescId	M	1	Identifier (Reference to NsVirtualLinkDesc)	Uniquely references a VLD.
flavourId	M	1	Identifier (Reference to VirtualLinkDf)	References a flavour within the VLD.
localAffinityOrAntiAffinityRule	M	0..N	LocalAffinityOrAntiAffinityRule	Specifies affinity and anti-affinity rules applicable between VLs instantiated from the referenced VLD. See clause 6.3.8.
affinityOrAntiAffinityGroupId	M	0..N	Identifier (Reference to AffinityOrAntiAffinityGroup)	Reference(s) the affinity or anti-affinity group(s) the VLs instantiated according to the VProfile belong to. See note 1.
maxBitrateRequirements	M	1	LinkBitrateRequirements	Specifies the maximum bitrate requirements for a VL instantiated according to this profile. See clause 6.5.5. See note 2.
minBitrateRequirements	M	1	LinkBitrateRequirements	Specifies the minimum bitrate requirements for a VL instantiated according to this profile. See clause 6.5.5. See note 2.
virtualLinkProtocolData	M	0..N	VirtualLinkProtocolData	Specifies the protocol data for an NS VL instantiated according to this profile. Cardinality 0 is used when no protocol data needs to be specified. See note 3.
<p>NOTE 1: Each identifier references an affinity or anti-affinity group which expresses affinity or anti-affinity relationship between the VL(s) using this VirtualLinkProfile and the VL(s) using other VirtualLinkProfile(s) in the same group.</p> <p>NOTE 2: These attributes are used to control scaling boundaries.</p> <p>NOTE 3: If the cardinality is more than 1, the order shall be the same as the order of the layerProtocol occurrences in the connectivityType attribute of the corresponding NsVirtualLinkDesc, i.e. the first occurrence of the virtualLinkProtocolData represents the highest layer protocol data, and the last occurrence represents the lowest layer protocol data.</p>				

6.3.5 AffinityOrAntiAffinityGroup information element

6.3.5.1 Description

The AffinityOrAntiAffinityGroup information element describes the affinity or anti-affinity relationship applicable between the VNF instances created using different VnfProfiles, the Virtual Link instances created using different VIProfiles or the nested NS instances created using different NsProfiles.

6.3.5.2 Attributes

The attributes of the AffinityOrAntiAffinityGroup information element shall follow the indications provided in table 6.3.5.2-1.

Table 6.3.5.2-1: Attributes of the AffinityOrAntiAffinityGroup information element

Attribute	Qualifier	Cardinality	Content	Description
groupId	M	1	Identifier	Identifier of this AffinityOrAntiAffinityGroup information element.
affinityOrAntiAffinity	M	1	Enum	Specifies the type of relationship that the members of the group have. VALUES: <ul style="list-style-type: none"> • AFFINITY • ANTI_AFFINITY
scope	M	1	Enum	Specifies the scope of the affinity or anti-affinity relationship. VALUES: <ul style="list-style-type: none"> • NFVI_NODE • NFVI_POP • NETWORK_LINK_AND_NODE • L2_NETWORK • CONTAINER_NAMESPACE • etc. See notes 1, 2 and 3.
<p>NOTE 1: When used in an anti-affinity relationship, the network-link-and-node scope is conceptually similar to link and node disjoint paths capabilities used commonly in network Traffic Engineering (TE). For example, as in Fast Reroute Resource Reservation Protocol Traffic Engineering (RSVP-TE) for Label-Switched Path (LSP) tunnels as introduced in IETF RFC 4090 [i.8].</p> <p>NOTE 2: When used in an affinity or anti-affinity relationship, the L2_NETWORK scope represents that the instances belonging to the same group shall share or not share, respectively, the same layer 2 NFVI resources.</p> <p>NOTE 3: The "CONTAINER_NAMESPACE" scope is used to express the affinity or anti-affinity relationship between VNF instances only when the VNFs are realized by sets of OS containers.</p>				

6.3.6 PnfProfile information element

6.3.6.1 Description

The PnfProfile information element describes additional data for a given PNF instance used in a DF.

6.3.6.2 Attributes

The attributes of the PnfProfile information element shall follow the indications provided in table 6.3.6.2-1.

Table 6.3.6.2-1: Attributes of the PnfProfile information element

Attribute	Qualifier	Cardinality	Content	Description
pnfProfileId	M	1	Identifier	Identifier of this PnfProfile information element. It uniquely identifies a PnfProfile.
pnfId	M	1	Identifier (Reference to Pnf)	References a PNFD.
pnfExtInvariantId	M	0..1	Identifier	Identifies a PNFD in a version independent manner. If present it shall have the same value as the pnfExtInvariantId in the PNFD referenced by the pnfId attribute. It allows for PNF instances during NS LCM the use of a PNFD different from the one referenced by the pnfId attribute, provided they have the same pnfExtInvariantId See note.
pnfVirtualLinkConnectivity	M	1..N	NsVirtualLinkConnectivity	Defines the connection information of the PNF, it contains connection relationship between a PNF connection point and an NS Virtual Link.

NOTE: This attribute should be included to avoid changes in the NSD caused by version changes in the PNFD.

6.3.7 NsVirtualLinkConnectivity information element

6.3.7.1 Description

The NsVirtualLinkConnectivity information element describes connection information between a connection point and an NS Virtual Link.

6.3.7.2 Attributes

The attributes of the NsVirtualLinkConnectivity information element shall follow the indications provided in table 6.3.7.2-1.

Table 6.3.7.2-1: Attributes of the NsVirtualLinkConnectivity information element

Attribute	Qualifier	Cardinality	Content	Description
virtualLinkProfileId	M	1	Identifier (Reference to VirtualLinkProfile)	References an NS VL profile.
constituentCpdId	M	1..N	CpdInConstituentElement	Describes a connection point on a VNF/PNF or a SAP which connects to virtual links instantiated from the profile identified in the virtualLinkProfileId attribute.
affinityOrAntiAffinityGroupId	M	0..N	Identifier (Reference to AffinityOrAntiAffinityGroup)	Reference(s) the affinity or anti-affinity group(s) the NsVirtualLinkConnectivity belong to. See notes 1 and 2.

NOTE 1: Each identifier references an affinity or anti-affinity group which expresses affinity or anti-affinity relationships between the connection created using this NsVirtualLinkConnectivity and the connection created using other NsVirtualLinkConnectivity(s) in the same group.

NOTE 2: The scope of AffinityOrAntiAffinityGroup when used in the NsVirtualLinkConnectivity shall be L2_NETWORK.

6.3.8 LocalAffinityOrAntiAffinityRule information element

6.3.8.1 Description

The LocalAffinityOrAntiAffinityRule information element specifies affinity or anti-affinity rules applicable to VNFs or VLs instantiated from the same VNFD or VLD.

6.3.8.2 Attributes

The attributes of the LocalAffinityOrAntiAffinityRule information element shall follow the indications provided in table 6.3.8.2-1.

Table 6.3.8.2-1: Attributes of the LocalAffinityOrAntiAffinityRule information element

Attribute	Qualifier	Cardinality	Content	Description
type	M	1	Enum	Specifies the rule. VALUES: <ul style="list-style-type: none"> • AFFINITY • ANTI_AFFINITY
scope	M	1	Enum	Specifies the scope of the rule. VALUES: <ul style="list-style-type: none"> • NFVI_POP • ZONE • ZONE_GROUP • NFVI_NODE • etc. See note.
NOTE:	When used in an anti-affinity relationship, the network-link-and-node scope is conceptually similar to link and node disjoint paths capabilities used commonly in network Traffic Engineering (TE). For example, as in Fast Reroute Resource Reservation Protocol Traffic Engineering (RSVP-TE) for Label-Switched Path (LSP) tunnels as introduced in IETF RFC 4090 [i.8].			

6.3.9 NsLevel information element

6.3.9.1 Description

The NsLevel information element describes the details of an NS level. An NS level consists of a list of involved entities, i.e. VNFs, VLs and/or nested NSs. For each involved VNF/nested NS, the number of instances required by the NS level is specified. For each involved VL, the bitrate requirements corresponding to the NS level are specified.

NS levels shall be used in the context of NS instantiation and in this case they are referred to as NS instantiation levels. Every VNF, VL and nested NS whose descriptor is referenced by the NS DF shall be involved in an NS instantiation level of the parent NS. If no instances of a given VNF/nested NS have to be deployed at NS instantiation time, the numberOfInstances attribute in the corresponding VnfToLevelMapping/NsToLevelMapping information element shall be set to 0.

NS levels may be used in the context of NS scaling and in this case they are referred to as NS scale levels. Only a subset of the VNFs, VLs and nested NSs whose descriptor is referenced by the NS DF may be involved in an NS scale level of the parent NS.

6.3.9.2 Attributes

The attributes of the NsLevel information element shall follow the indications provided in table 6.3.9.2-1.

Table 6.3.9.2-1: Attributes of the NsLevel information element

Attribute	Qualifier	Cardinality	Content	Description
nsLevelId	M	1	Identifier	Identifier of this NsLevel information element. It uniquely identifies an NS level within the DF.
description	M	1	String	Human readable description of the NS level.
vnfToLevelMapping	M	0..N	VnfToLevelMapping	Specifies the profile of the VNFs involved in this NS level and, for each of them, the required number of instances. See note.
virtualLinkToLevelMapping	M	0..N	VirtualLinkToLevelMapping	Specifies the profile of the VLs involved in this NS level and, for each of them, the needed bandwidth. See note.
nsToLevelMapping	M	0..N	NsToLevelMapping	Specifies the profile of the nested NSs involved in this NS level and, for each of them, the required number of instances. See note.
NOTE: At least one attribute between vnfToLevelMapping, virtualLinkToLevelMapping and nsToLevelMapping shall be present.				

6.3.10 Void

6.3.11 NsProfile information element

6.3.11.1 Description

The NsProfile information element specifies the profile to be used for a nested NS.

6.3.11.2 Attributes

The attributes of the NsProfile information element shall follow the indications provided in table 6.3.11.2-1.

Table 6.3.11.2-1: Attributes of the NsProfile information element

Attribute	Qualifier	Cardinality	Content	Description
nsProfileId	M	1	Identifier	Identifies an NS profile.
nsdId	M	1	Identifier (Reference to Nsd)	References the NSD applicable to NS instantiated according to this profile.
nsdExtInvariantId	M	0..1	Identifier	Identifies an NSD in a version independent manner. If present it shall have the same value as the nsdExtInvariantId in the NSD referenced by the nsdId attribute. It allows for nested NS instances during NS LCM the use of an NSD different from the one referenced by the nsdId attribute, provided they have the same nsdExtInvariantId. See note 4.
nsDfId	M	1	Identifier (Reference to NsDf)	References the applicable NS DF within the scope of the NSD.
nsInstantiationLevelId	M	0..1	Identifier (Reference to NsLevel)	References the NS level within the referenced NS DF to be used in the context of the parent NS instantiation. See note 2.
targetNsScaleLevelInfo	M	0..N	NsScaleInfo	This attribute is applicable for NS target scale level instantiation. For each NS scaling aspect of the deployment flavour applicable to this NS instance, defines the target NS scale level to which the NS instance to be instantiated. See notes 2 and 3.
minNumberOfInstances	M	1	Integer	Minimum number of nested NS instances based on the referenced NSD that is permitted to exist for this NsProfile.
maxNumberOfInstances	M	1	Integer	Maximum number of nested NS instances based on the referenced NSD that is permitted to exist for this NsProfile.
affinityOrAntiAffinityGroupId	M	0..N	Identifier (Reference to AffinityOrAntiAffinityGroup)	Reference(s) the affinity or anti-affinity group(s) the NSs created according to this NsProfile belong to. See note 1.
nsVirtualLinkConnectivity	M	1..N	NsVirtualLinkConnectivity	Defines the connection information of the NS, it contains connection relationship between an NS SAP and an NS virtual Link of the composite NS.
<p>NOTE 1: Each identifier references an affinity or anti-affinity group which expresses affinity or anti-affinity relationships between the NS instance(s) created using this NsProfile and the NS instance(s) created using other NsProfile(s) in the same group.</p> <p>NOTE 2: The target size for NS instantiation may be provided as NS instantiation level of the DF as defined in the NSD, or alternatively as targetNsScaleLevelInfo, but not both. If none of the two attributes (nsInstantiationLevelId or targetNsScaleLevelInfo) are present, the default NS instantiation level as declared in the NSD shall be used.</p> <p>NOTE 3: If targetNsScaleLevelInfo is specified, information provided in targetNsScaleLevelInfo shall be used to calculate the number of instances of the VNFs /nested NSs referred in the NSD.</p> <p>NOTE 4: This attribute should be included to avoid changes in the composite NSD caused by version changes in the nested NSD.</p>				

6.3.12 Dependencies information element

6.3.12.1 Description

The Dependencies information element provides indications on the order in which VNFs associated to different VNF Profiles and/or nested NSs associated to different NS Profiles are to be instantiated.

6.3.12.2 Attributes

The attributes of the Dependencies information element shall follow the indications provided in table 6.3.12.2-1.

Table 6.3.12.2-1: Attributes of the Dependencies information element

Attribute	Qualifier	Cardinality	Content	Description
primaryId	M	1..N	Identifier (Reference to VnfProfile or NsProfile)	References a VnfProfile or NsProfile for describing dependencies between VNF and/or nested NS instances in terms of primary entities. See note.
secondaryId	M	1..N	Identifier (Reference to VnfProfile or NsProfile)	References a VnfProfile or NsProfile for describing dependencies between VNF and/or nested NS instances in terms of secondary entities. See note.
NOTE: NFV Management and Orchestration functions shall instantiate VNFs from the VnfProfile and/or nested NSs from the NsProfile referenced in the primaryId attribute before instantiating VNFs from the VnfProfile and/or nested NSs from the NsProfile referenced in the secondaryId attribute.				

6.3.13 VirtualLinkProtocolData information element

6.3.13.1 Description

The VirtualLinkProtocolData describes the protocol layer and associated protocol data for a NS virtual link.

6.3.13.2 Attributes

The attributes of the VirtualLinkProtocolData information element shall follow the indications provided in table 6.3.13.2-1.

Table 6.3.13.2-1: Attributes of the VirtualLinkProtocolData information element

Attribute	Qualifier	Cardinality	Content	Description
associatedLayerProtocol	M	1	Enum	One of the values of the attribute layerProtocol of the ConnectivityType IE. See clause 6.5.3.2. VALUES: <ul style="list-style-type: none"> • ETHERNET • MPLS • ODU2 • IPV4 • IPV6 • PSEUDO_WIRE • etc.
l2ProtocolData	M	0..1	L2ProtocolData	Specifies the L2 protocol data for this NS virtual link. Shall be present when the associatedLayerProtocol attribute indicates a L2 protocol and shall be absent otherwise.
l3ProtocolData	M	0..1	L3ProtocolData	Specifies the L3 protocol data for this NS virtual link. Shall be present when the associatedLayerProtocol attribute indicates a L3 protocol and shall be absent otherwise.

6.3.14 L2ProtocolData information element

6.3.14.1 Description

The L2ProtocolData information element describes the L2 protocol related data for an NS virtual link.

6.3.14.2 Attributes

The attributes of the L2ProtocolData information element shall follow the indications provided in table 6.3.14.2-1.

Table 6.3.14.2-1: Attributes of the L2ProtocolData information element

Attribute	Qualifier	Cardinality	Content	Description
name	M	0..1	String	Network name associated with this L2 protocol.
networkType	M	0..1	Enum	Specifies the network type for this L2 protocol. VALUES: <ul style="list-style-type: none"> • FLAT • VLAN • VXLAN • GRE See note.
vlanTransparent	M	0..1	Boolean	Specifies whether to support VLAN transparency for this L2 protocol or not.
mtu	M	0..1	Integer	Specifies the maximum transmission unit (MTU) value for this L2 protocol.
segmentationId	M	0..1	String	If present, specifies a specific virtualised network segment, which depends on the network type. For e.g. VLAN ID for VLAN network type and tunnel ID for GRE/VXLAN network types. See note.
NOTE: If this attribute is included in the NSD, the attribute value shall be provided at run-time, unless a default value is provided at design time in the NSD. If a default value is provided at design-time, this value may be overridden at run-time.				

6.3.15 L3ProtocolData information element

6.3.15.1 Description

The L3ProtocolData information element describes the L3 protocol related data for an NS virtual link.

6.3.15.2 Attributes

The attributes of the L3ProtocolData information element shall follow the indications provided in table 6.3.15.2-1.

Table 6.3.15.2-1: Attributes of the L3ProtocolData information element

Attribute	Qualifier	Cardinality	Content	Description
name	M	0..1	String	Network name associated with this L3 protocol.
ipVersion	M	1	Enum	Specifies IP version of this L3 protocol. VALUES: <ul style="list-style-type: none"> • IPV4 • IPV6 See note 1.
cidr	M	1	Not specified	Specifies the CIDR (Classless Inter-Domain Routing) of this L3 protocol. See note 2. The network address and subnet mask in cidr format.
ipAllocationPools	M	0..N	Not specified	Specifies the allocation pools with start and end IP addresses for this L3 protocol. See note 2.
NOTE 1: The value of the ipVersion attribute shall be consistent with the value of the layerProtocol attribute of the ConnectivityType IE (see clause 6.5.3.2).				
NOTE 2: If this attribute is included in the NSD, the attribute value shall be provided at run-time, unless a default value is provided at design time in the NSD. If a default value is provided at design-time, this value may be overridden at run-time.				

6.3.16 VnfScaleInfo information element

6.3.16.1 Description

The VnfScaleInfo information element represents a VNF scale level for a particular scaling aspect.

6.3.16.2 Attributes

The attributes of the VnfScaleInfo information element shall follow the indications provided in table 6.3.16.2-1.

Table 6.3.16.2-1: Attributes of the VnfScaleInfo information element

Attribute	Qualifier	Cardinality	Content	Description
aspectId	M	1	Identifier (Reference to ScalingAspect)	References the scaling aspect of the VNF.
scaleLevel	M	1	Integer	The scale level, greater than or equal to 0.
NOTE: Vertical scaling (scale up, scale down) is not supported in the present document.				

6.4 Information elements related to the VNF Forwarding Graph Descriptor

6.4.1 Introduction

Clauses 6.4.2 to 6.4.5.2 define the information elements related to the VNFFGD.

6.4.2 Vnffgd information element

6.4.2.1 Description

The Vnffgd information element specifies a topology of connectivity of an NS and optionally forwarding rules applicable to the traffic conveyed over this topology.

6.4.2.2 Attributes

The attributes of the Vnffgd information element shall follow the indications provided in table 6.4.2.2-1.

Table 6.4.2.2-1: Attributes of the Vnffgd information element

Attribute	Qualifier	Cardinality	Content	Description
vnffgdId	M	1	Identifier	Identifier of this Vnffgd information element. It uniquely identifies a VNFFGD.
vnfProfileId	M	1..N	Identifier (Reference to VnfProfile)	References the VnfProfile of a constituent VNF. See notes 1 and 2.
pnfProfileId	M	0..N	Identifier (Reference to PnfProfile)	References the PnfProfile of a constituent PNF. See notes 1 and 2.
nestedNsProfileId	M	0..N	Identifier (Reference to NsProfile)	References the NsProfile of a nestedNS. See notes 1 and 2.
virtualLinkProfileId	M	1..N	Identifier (Reference to VirtualLinkProfile)	References the Virtual Link Profile of a constituent VL. See note 3.
nfpPositionElement	M	1..N	NfpPositionElement	NfpPositionElement associated with one of the constituent VNF Profile, PNF Profile or NS Profile of a nested NS.
nfpd	M	0..N	Nfpd	The network forwarding path associated to the VNFFG. See clause 6.4.3.
NOTE 1: The list of constituent VNFs, PNFs, and nested NSs of a VNFFG can be identical to the list of constituent VNFs, PNFs and nested NSs of the parent NSD, or can be a subset of it.				
NOTE 2: The presence of a VnfProfile or PnfProfile identifier in a VNFFGD does not imply that all connection points instantiated from all related CPDs are connected to the VNFFG instantiated using the VNFFGD.				
NOTE 3: The presence of a VL profile identifier in a VNFFGD does not imply that all connection points connected to the VLs instantiated using this profile are also connected to the VNFFG instantiated using the VNFFGD.				

6.4.3 Nfpd information element

6.4.3.1 Description

The Nfpd information element associates traffic flow criteria to a list of descriptors associated to the connection points and service access points to be visited by traffic flows matching these criteria.

6.4.3.2 Attributes

The attributes of the Nfpd information element shall follow the indications provided in table 6.4.3.2-1.

Table 6.4.3.2-1: Attributes of the Nfpd information element

Attribute	Qualifier	Cardinality	Content	Description
nfpdId	M	1	Identifier	Identifies this nfpd information element within a VNFFGD.
nfpRule	M	0..1	Rule	Provides an NFP classification and selection rule. The rule may be expressed as a criteria constructed out of atomic assertions linked by Boolean operators AND, OR and NOT. See note 1.
nfpPositionDesc	M	1..N	NfpPositionDesc	Describes a position in the NFP in terms of one or more CPDs and SAPDs and rules for distributing the traffic among CP and SAP instances created from the CPDs and SAPDs. See note 2.
NOTE 1: Examples of atomic assertions are assertions on packet header fields' values, date and time ranges, etc.				
NOTE 2: When multiple values are provided, the order is significant and specifies the sequence of connection points (or group of connection points) to be traversed by traffic flows.				

6.4.4 Void

6.4.5 NfpPositionDesc information element

6.4.5.1 Description

The NfpPositionDesc information element references one or more CPDs or SAPDs and provides rules on how to route traffic flows among CP or SAP instances instantiated from these descriptors.

6.4.5.2 Attributes

The attributes of the NfpPositionDesc information element shall follow the indications provided in table 6.4.5.2-1.

Table 6.4.5.2-1: Attributes of the NfpPositionDesc information element

Attribute	Qualifier	Cardinality	Content	Description
nfpPositionDescId	M	1	Identifier	Identifier of this NfpPositionDesc element.
nfpPositionElementId	M	1..N	Identifier (Reference to NfpPositionElement)	References one or a pair of CPDs or SAPDs. See note 2.
forwardingBehaviour	M	0..1	Enum	Specifies a rule to apply to forward traffic to CP or SAP instances corresponding to the referenced CP profile(s). The minimum list of rules to be supported shall include: <ul style="list-style-type: none"> • ALL = Traffic flows shall be forwarded simultaneously to all CP or SAP instances created from the referenced CP profile(s) • LB = Traffic flows shall be forwarded to one CP or SAP instance created from the referenced CP profile(s) selected based on a load-balancing algorithm VALUES: <ul style="list-style-type: none"> • ALL • LB • etc. See note 1.
forwardingBehaviourInputParameters	M	0..1	Not specified	Provides input parameters to configure the forwarding behaviour (e.g. identifies a load balancing algorithm).
<p>NOTE 1: When no rules are provided and there are multiple CP or SAP instances corresponding to the referenced CPD(s) and SAPD(s), the VIM and/or the NFVI are expected to apply NFP-independent rules determined by means outside the scope of the present document.</p> <p>NOTE 2: An NFP position corresponds to one or more instances of the same Service Function (SF) in a given Service Function Chain, as defined in IETF RFC 7665 [i.6]. An NfpPositionElement describes the ingress and egress connection points corresponding to an instance of this SF. As illustrated in Annex A, these connection points may - but need not - be attached to the same VNF, PNF or nested NS instance.</p>				

6.4.6 NfpPositionElement information element

6.4.6.1 Description

The NfpPositionElement information element references one or two CPD(s) or SAPD(s) for a given VnfProfile, PnfProfile or NsProfile. The usage of profiles enables differentiating the CPDs or SAPDs specified in the same VNFD/PNFD/NSD that are applicable to different VNF/PNF/NS instances derived from the same VNFD/PNFD/NSD.

6.4.6.2 Attributes

The attributes of the NfpPositionElement information element shall follow the indications provided in table 6.4.6.2-1.

Table 6.4.6.2-1: Attributes of the NfpPositionElement information element

Attribute	Qualifier	Cardinality	Content	Description
nfpPositionElementId	M	1	Identifier	Identifier of this NfpPositionElement information element. It uniquely identifies an NfpPositionElement.
nfpPositionElementDesc	M	1..2	CpdInConstituentElement	Specifies a CPD or SAPD in the context of a profile of an NS constituent element. See note 5.
NOTE 1: Void. NOTE 2: Void. NOTE 3: Void. NOTE 4: Void. NOTE 5: When only one value is provided, the ingress and egress traffic is associated to a single CPD or SAPD. When two values are provided, the ingress CP/SAP is associated to the first value and the egress CP/SAP is associated to the second value.				

6.4.7 ConstituentProfileElements information element - DEPRECATED

6.4.7.1 Description

The ConstituentProfileElements information element references a CPD or a SAPD for a given VnfProfile, PnfProfile or NsProfile. This information element was deprecated in ETSI GS NFV-IFA 014 [i.9], V3.3.1.

6.4.7.2 Attributes

The attributes of the ConstituentProfileElements information element shall follow the indications provided in table 6.4.7.2-1.

Table 6.4.7.2-1: Attributes of the ConstituentProfileElements information element

Attribute	Qualifier	Cardinality	Content	Description
constituentBaseElementId	M	1	Identifier (Reference to VnfProfile or PnfProfile or NsProfile)	References the constituents of the CpProfile.
constituentCpdId	M	1	Identifier (Reference to VnfExtCpd or PnfExtCpd or Sapd)	References the VNF external CPD for a given VnfProfile, or the PNF external CPD for a given PnfProfile, or an NS SAPD for a give NsProfile identified by the constituentBasedElementId.

6.4.8 CpdInConstituentElement information element

6.4.8.1 Description

The CpdInConstituentElement information element enables identifying a CPD or SAPD in the context of an NS constituent.

6.4.8.2 Attributes

The attributes of the CpdInConstituentElement information element shall follow the indications provided in table 6.4.8.2-1.

Table 6.4.8.2-1: Attributes of the CpdInConstituentElement information element

Attribute	Qualifier	Cardinality	Content	Description
constituentBaseElementId	M	1	Identifier (Reference to VnfProfile or PnfProfile or NsProfile)	References the profile of an NS constituent.
constituentCpdId	M	1	Identifier (Reference to VnfExtCpd or PnfExtCpd or Sapd)	References the VNF external CPD for a given VnfProfile, or the PNF external CPD for a given PnfProfile, or an NS SAPD for a given NsProfile identified by the constituentBaseElementId.

6.5 Information elements related to the Network Service Virtual Link Descriptor

6.5.1 Introduction

Clauses 6.5.2 up to 6.5.6.2 define the information elements related to the NS VLD.

6.5.2 NsVirtualLinkDesc information element

6.5.2.1 Description

The NsVirtualLinkDesc information element provides general information enabling the instantiation of virtual links.

6.5.2.2 Attributes

The attributes of the NsVirtualLinkDesc information element shall follow the indications provided in table 6.5.2.2-1.

Table 6.5.2.2-1: Attributes of the NsVirtualLinkDesc information element

Attribute	Qualifier	Cardinality	Content	Description
virtualLinkDescId	M	1	Identifier	Identifier of the NsVirtualLinkDesc information element. It uniquely identifies a VLD.
connectivityType	M	1	ConnectivityType	See clause 6.5.3.
virtualLinkDf	M	1..N	VirtualLinkDf	See clause 6.5.4.
testAccess	M	0..N	String	Specifies test access facilities expected on the VL (e.g. none, passive monitoring, or active (intrusive) loopbacks at endpoints).
description	M	0..1	String	Provides human-readable information on the purpose of the virtual link (e.g. VL for control plane traffic).

6.5.3 ConnectivityType information element

6.5.3.1 Description

The ConnectivityType information element specifies the protocol exposed by a VL and the flow pattern supported by the VL.

6.5.3.2 Attributes

The attributes of the ConnectivityType information element shall follow the indications provided in table 6.5.3.2-1.

Table 6.5.3.2-1: Attributes of the ConnectivityType information element

Attribute	Qualifier	Cardinality	Content	Description
layerProtocol	M	1..N	Enum	Specifies the protocols that the VL uses. VALUES: <ul style="list-style-type: none"> • ETHERNET • MPLS • ODU2 • IPV4 • IPV6 • PSEUDO_WIRE • etc. See notes 1 and 2.
flowPattern	M	0..1	String	Specifies the flow pattern of the connectivity (Line, Tree, Mesh, etc.).
NOTE 1: The top layer protocol of the VL protocol stack shall always be provided. The lower layer protocols may be included when there are specific requirements on these layers.				
NOTE 2: If more than 1 values are present, the first value represents the highest layer protocol data, and the last value represents the lowest layer protocol data.				

6.5.4 VirtualLinkDf information element

6.5.4.1 Description

The VirtualLinkDf information element specifies properties for instantiating a VL according to a specific flavour.

6.5.4.2 Attributes

The attributes of the VirtualLinkDf information element shall follow the indications provided in table 6.5.4.2-1.

Table 6.5.4.2-1: Attributes of the VirtualLinkDf information element

Attribute	Qualifier	Cardinality	Content	Description
flavourId	M	1	Identifier	Identifies this VirtualLinkDf information element within a VLD.
qos	M	0..1	NsQoS	See clause 6.5.6.
serviceAvailabilityLevel	M	0..1	Integer	If present, specifies the service availability level for the VL instance created from this DF. See note.
NOTE: Either the serviceAvailabilityLevel attribute of NS DF or the serviceAvailabilityLevel attribute of the VL DF may be provided, but not both.				

6.5.5 LinkBitrateRequirements information element

6.5.5.1 Description

The LinkBitrateRequirements information element describes the requirements in terms of bitrate for a VL.

6.5.5.2 Attributes

The attributes of the LinkBitrateRequirements information element shall follow the indications provided in table 6.5.5.2-1.

Table 6.5.5.2-1: Attributes of the LinkBitrateRequirements information element

Attribute	Qualifier	Cardinality	Content	Description
root	M	1	Number	Specifies the throughput requirement of the link (e.g. bitrate of E-Line, root bitrate of E-Tree, aggregate capacity of E-LAN).
leaf	M	0..1	Number	Specifies the throughput requirement of leaf connections to the link when applicable to the connectivity type (e.g. for E-Tree and E-LAN branches). See note.
NOTE: The present document does not specify the means to declare different bitrate requirements for leaf connections (e.g. E-LAN leaves).				

6.5.6 NsQoS information element

6.5.6.1 Description

The NsQoS information element specifies quality of service parameters applicable to a NS VL.

6.5.6.2 Attributes

The attributes of the NsQoS information element shall follow the indications provided in table 6.5.6.2-1.

Table 6.5.6.2-1: Attributes of the NsQoS information element

Attribute	Qualifier	Cardinality	Content	Description
latency	M	1	Number	Specifies the maximum latency in ms.
packetDelayVariation	M	1	Number	Specifies the maximum jitter in ms.
packetLossRatio	M	0..1	Number	Specifies the maximum packet loss ratio.
priority	M	0..1	Integer	Specifies the priority level in case of congestion on the underlying physical links.

6.6 Information elements related to the PNFD

6.6.1 Introduction

Clauses 6.6.2 up to 6.6.4.2 define the information elements related to the PNFD.

6.6.2 Pnfd information element

6.6.2.1 Description

The Pnfd information element is a deployment template enabling on-boarding PNFs and referencing them from an NSD. It focuses on connectivity aspects only.

6.6.2.2 Attributes

The attributes of the Pnfd information element shall follow the indications provided in table 6.6.2.2-1.

Table 6.6.2.2-1: Attributes of the Pnfd information element

Attribute	Qualifier	Cardinality	Content	Description
pnfdId	M	1	Identifier	Identifier of this Pnfd information element. It uniquely identifies the PNFD.
functionDescription	M	1	String	Describes the PNF function
provider	M	1	String	Specifies the provider of the PNFD. See note 1.
version	M	1	Version	Specifies the version of the PNFD.
pnfdInvariantId	M	1	Identifier	Identifies a PNFD in a version independent manner. This attribute is invariant across versions of PNFD with no constraint on the changes across versions.
pnfdExtInvariantId	M	0..1	Identifier	Identifies a PNFD in a version independent manner. This attribute is invariant across versions of the PNFD that expose the same external connectivity, i.e. same number of pnfExtCpds and same identifiers. See note 2.
name	M	1	String	Provides the human readable name of the PNFD.
pnfExtCp	M	1..N	PnfExtCpd	Specifies the characteristics of one or more connection points where to connect the PNF to a VL. See clause 6.6.4.
geographicalLocationInfo	M	0..1	Not specified	It provides information about the geographical location (e.g. geographic coordinates or address of the building, etc.) of the PNF. The cardinality 0 is used when the location is unknown.
NOTE 1: The provider of the PNFD might be different from the provider of the PNF.				
NOTE 2: This condition implies that PNFDs with the same pnfExtInvariantId preserve external invariancy. Therefore, fulfilling this condition allows to use a different version of a PNFD in an NS instance without modification of the NSD on which the NS instance is based. The use of a different version of a PNFD is ultimately under the control of the service provider of the NS and it should consider if the NSD fulfils the requirements of the PnfExtCpds (e.g. bitrate, IP version, etc.).				

6.6.3 Cpd information element

6.6.3.1 Description

The Cpd information element is defined in clause 7.1.6.3 of ETSI GS NFV-IFA 011 [2]. This is an abstract class used as parent for the various Cpd classes.

6.6.3.2 Attributes

The attributes of the Cpd information element are defined in clause 7.1.6.3 of ETSI GS NFV-IFA 011 [2].

6.6.4 PnfExtCpd information element

6.6.4.1 Description

A PnfExtCpd is a type of Cpd and describes the characteristics of an external interface, a.k.a. an external CP, where to connect the PNF to a VL. A PnfExtCpd inherits from the Cpd Class (see clause 6.6.3). All attributes of the Cpd are also attributes of the PnfExtCpd.

6.6.4.2 Attributes

The attributes of the PnfExtCpd information element shall follow the indications provided in table 6.6.4.2-1.

Table 6.6.4.2-1: Attributes of the PnfExtCpd information element

Attribute	Qualifier	Cardinality	Content	Description
(inherited attributes)				All attributes inherited from Cpd.

6.7 Information elements related to scaling

6.7.1 Introduction

Clauses 6.7.2 to 6.7.6.2 define the information elements related to scaling.

6.7.2 NsScalingAspect information element

6.7.2.1 Description

The NsScalingAspect information element describes the details of an NS scaling aspect. An NS scaling aspect is an abstraction representing a particular "dimension" or "property" along which a given NS can be scaled. Defining NS levels, in this context also known as NS scale levels, within an NS scaling aspect allows to scale NS instances "by steps", i.e. to increase/decrease their capacity in a discrete manner moving from one NS scale level to another. Scaling by a single step does not imply that exactly one instance of each entity involved in the NS scale level is created or removed.

6.7.2.2 Attributes

The attributes of the NsScalingAspect information element shall follow the indications provided in table 6.7.2.2-1.

Table 6.7.2.2-1: Attributes of the NsScalingAspect information element

Attribute	Qualifier	Cardinality	Content	Description
nsScalingAspectId	M	1	Identifier	Identifier of this NsScalingAspect information element. It Uniquely identifies the NS scaling aspect in an NSD.
name	M	1	String	Provides a human readable name of the NS scaling aspect.
description	M	1	String	Provides a human readable description of the NS scaling aspect.
nsScaleLevel	M	1..N	NsLevel	Describes the details of an NS level. See clause 6.3.9. See note.
NOTE: Only a subset of the VNFs, VFs and nested NSs whose descriptor is referenced by the NS DF may be involved in an NS scale level of the parent NS.				

6.7.3 Void

6.7.4 VnfToLevelMapping information element

6.7.4.1 Description

The VnfToLevelMapping information element specifies the profile to be used for a VNF involved in a given NS level and the required number of instances.

6.7.4.2 Attributes

The attributes of the VnfToLevelMapping information element shall follow the indications provided in table 6.7.4.2-1.

Table 6.7.4.2-1: Attributes of the VnfToLevelMapping information element

Attribute	Qualifier	Cardinality	Content	Description
vnfProfileId	M	1	Identifier (Reference to VnfProfile)	References the profile to be used for a VNF involved in an NS level.
numberOfInstances	M	1	Integer	Specifies the number of VNF instances required for an NS level. See notes 1 to 3.
NOTE 1: It shall be in the range of minNumberOfInstances-maxNumberOfInstances, as specified in the referenced VnfProfile.				
NOTE 2: When the corresponding NS level is used in the context of NS instantiation, the numberOfInstances attribute specifies the number of VNF instances to be deployed.				
NOTE 3: When the corresponding NS level is used in the context of NS scaling, the numberOfInstances attribute does not specify the number of VNF instances to be added/removed when reaching that NS scale level. The actual number of VNF instances to be added/removed can be derived by subtracting the numberOfInstances declared in the source NS scale level from the numberOfInstances declared in the target NS level of the scaling request.				

6.7.5 VirtualLinkToLevelMapping information element

6.7.5.1 Description

The VirtualLinkToLevelMapping information element specifies the profile to be used for a VL involved in a given NS level and bitrate requirements.

6.7.5.2 Attributes

The attributes of the VirtualLinkToLevelMapping information element shall follow the indications provided in table 6.7.5.2-1.

Table 6.7.5.2-1: Attributes of the VirtualLinkToLevelMapping information element

Attribute	Qualifier	Cardinality	Content	Description
virtualLinkProfileId	M	1	Identifier (Reference to VirtualLinkProfile)	References the profile to be used for a VL involved in an NS level.
bitrateRequirements	M	1	LinkBitrateRequirements	Specifies the bit rate requirements for the NS level. See note.
NOTE: It shall be in the range of minBitrateRequirements-maxBitrateRequirements, as specified in the referenced VirtualLinkProfile.				

6.7.6 NsToLevelMapping information element

6.7.6.1 Description

The NsToLevelMapping information element specifies the profile to be used for a nested NS involved in a given NS level and the required number of instances.

6.7.6.2 Attributes

The attributes of the NsToLevelMapping information element shall follow the indications provided in table 6.7.6.2-1.

Table 6.7.6.2-1: Attributes of the NsToLevelMapping information element

Attribute	Qualifier	Cardinality	Content	Description
nsProfileId	M	1	Identifier (Reference to NsProfile)	References the profile to be used for a nested NS involved in the NS level.
numberOfInstances	M	1	Integer	Specifies the number of nested NS instances required for the NS scale level. See notes 1 to 3.
<p>NOTE 1: It shall be in the range of minNumberOfInstances-maxNumberOfInstances, as specified in the referenced NsProfile.</p> <p>NOTE 2: When the corresponding NS level is used in the context of NS instantiation, the numberOfInstances attribute specifies the number of nested NS instances to be deployed.</p> <p>NOTE 3: When the corresponding NS level is used in the context of NS scaling, the numberOfInstances attribute does not specify the number of nested NS instances to be added/removed when reaching that NS scale level. The actual number of nested NS instances to be added/removed can be derived by subtracting the numberOfInstances declared in the source NS scale level from the numberOfInstances declared in the target NS level of the scaling request.</p>				

Annex A (informative): Support of service function chaining

A.1 Introduction

Within an NSD, the NFPD information element is intended to serve as the main input for supporting Service Function Chaining (SFC) as specified in IETF RFC 7665 [i.6] in an NFV environment, by leveraging the NFV-MANO and NFVI capabilities.

NOTE: Scenarios where service chaining is realized in the tenant domain (i.e. classification and forwarding occurs in VNF instances) rather than the NFVI are outside the scope of the present annex, as in such cases service chaining does not rely on the contents of the NSD and is not visible to NFV-MANO.

To take advantage of the service function chaining capabilities supported by NFV-MANO, NS designers are expected to include one or more NFPDs in one or more VNFFGDs within the NSD.

The NSD management interface specified in ETSI GS NFV-IFA 013 [i.2] enables on-boarding a set of NFPDs as part of the NSD. The Update NS operation of the NS lifecycle management interface specified in ETSI GS NFV-IFA 013 [i.2] enables adding or removing NFP instances from an existing NS instance.

A.2 IETF SFC concepts

Table A.2-1 provides an overview of the mapping of SFC concepts as described in IETF RFC 7665 [i.6] and NFV constructs.

NOTE: In some cases, when embedding examples and additional explanations, the IETF definition has been truncated.

Table A.2-1: SFC concepts to NFV constructs mapping

IETF RFC 7665 [i.6] term	IETF RFC 7665 [i.6] (simplified) definition	Equivalent NFV constructs
Network Service	<i>"An offering provided by an operator that is delivered using one or more service functions. This may also be referred to as a "composite service". The term "service" is used to denote a "network service" in the context of this document."</i>	A Network Service as defined in IETF RFC 7665 [i.6] can be deployed as one or more VNF combined to form an NFV NS as defined in ETSI GS NFV 003 [1].
Classification	<i>"Locally instantiated matching of traffic flows against policy for subsequent application of the required set of network service functions. The policy may be customer/network/service specific."</i>	The nfpRule attribute of the Nfpd information element provides the input to the Classification.
Classifier	<i>"An element that performs Classification."</i>	This functionality is provided by the NFVI network domain.
Service Function Chain	<i>"A service function chain defines an ordered set of abstract service functions and ordering constraints that must be applied to packets and/or frames and/or flows selected as a result of classification."</i>	A service function chain is described by an Nfpd information element.

IETF RFC 7665 [i.6] term	IETF RFC 7665 [i.6] (simplified) definition	Equivalent NFV constructs
Service Function (SF)	<i>"A function that is responsible for specific treatment of received packets. A Service Function can act at various layers of a protocol stack (e.g. at the network layer or other OSI layers). As a logical component, a service function can be realized as a virtual element or be embedded in a physical network element. [...] Multiple occurrences of the service function can exist in the same administrative domain."</i>	An SF can be deployed as one or several VNFs or PNFs. In the latter case, the group of network functions can be represented as a nested NS. Multiple SFs can map to one VNF or PNF, as long as an external connection point provides access to this SF within the VNF or PNF. Within an Nfpp information element, an NfppPositionDesc corresponds to one or more instances of the same SF in a given Service Function Chain, as defined in IETF RFC 7665 [i.6]. Within an NfppPositionDesc information element, an NfppPositionElement describes the ingress and egress connection points corresponding to an instance of this SF. These connection points may - but need not - be attached to the same VNF, PNF or nested NS instance.
Service Function Forwarder (SFF)	<i>"A service function forwarder is responsible for forwarding traffic to one or more connected service functions according to information carried in the SFC encapsulation, as well as handling traffic coming back from the SF."</i>	This functionality is provided by the NFVI network domain.
Service Function Path (SFP)	<i>"The service function path is a constrained specification of where packets assigned to a certain service function path must go. While it may be so constrained as to identify the exact locations, it can also be less specific. The SFP provides a level of indirection between the fully abstract notion of service chain as a sequence of abstract service functions to be delivered, and the fully specified notion of exactly which SFF/SFs the packet will visit when it actually traverses the network."</i>	An SFP is derived from an NFP created by the NFVO from an NFPD. See note.
SFC Encapsulation	<i>"The SFC encapsulation provides, at a minimum, SFP identification, and is used by the SFC-aware functions, such as the SFF and SFC-aware SFs. The SFC encapsulation is not used for network packet forwarding. In addition to SFP identification, the SFC encapsulation carries metadata including data-plane context information."</i>	This functionality is provided by the NFVI network domain.
Rendered Service Path (RSP)	<i>"Within an SFP, packets themselves are of course transmitted from and to specific places in the network, visiting a specific sequence of SFFs and SFs. This sequence of actual visits by a packet to specific SFFs and SFs in the network is known as the Rendered Service Path (RSP)."</i>	The RSP for a given packet is determined by the NFVI by applying runtime decisions, in particular those resulting from load balancing.
SFC-Enabled Domain	<i>"A network or region of a network that implements SFC. An SFC-enabled domain is limited to a single network administrative domain."</i>	An infrastructure domain supporting NFP management is an SFC-enabled domain.
SFC Proxy	<i>"Removes and inserts SFC encapsulation on behalf of an SFC-unaware service function. SFC proxies are logical elements."</i>	This functionality is provided by the NFVI network domain.
NOTE: An NFPD is always embedded in a VNFFGD. However, a VNFFGD is not a forwarding path descriptor and has no direct mapping to SFC concepts.		

A.3 Use of the NFP Management interface

The NFVO requests the creation of NFP instances using the Create NFP operation from the NFP management interface specified in ETSI GS NFV-IFA 005 [i.7].

A.4 Mapping

An SF can be deployed as one or several VNFs. Multiple SFs can map to one VNF, as long as an external connection point provides access to this SF within the VNF.

Figure A.4-1 illustrates the case where there is a one-to-one mapping between 3 SFs and 3 VNFs.

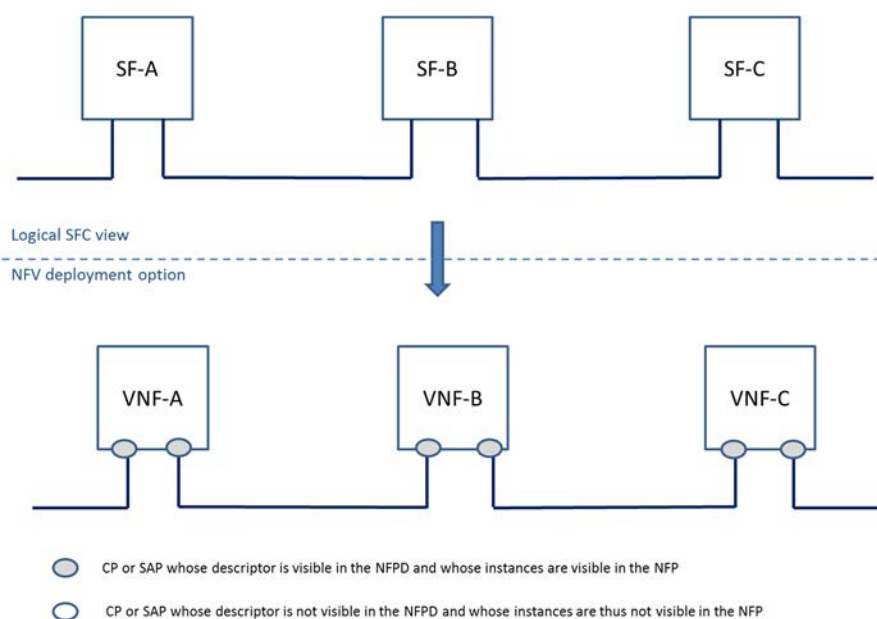

Figure A.4-1: One-to-one mapping

Figure A.4-2 illustrates the case where two SFs are implemented as two VNFCs within the same VNF.

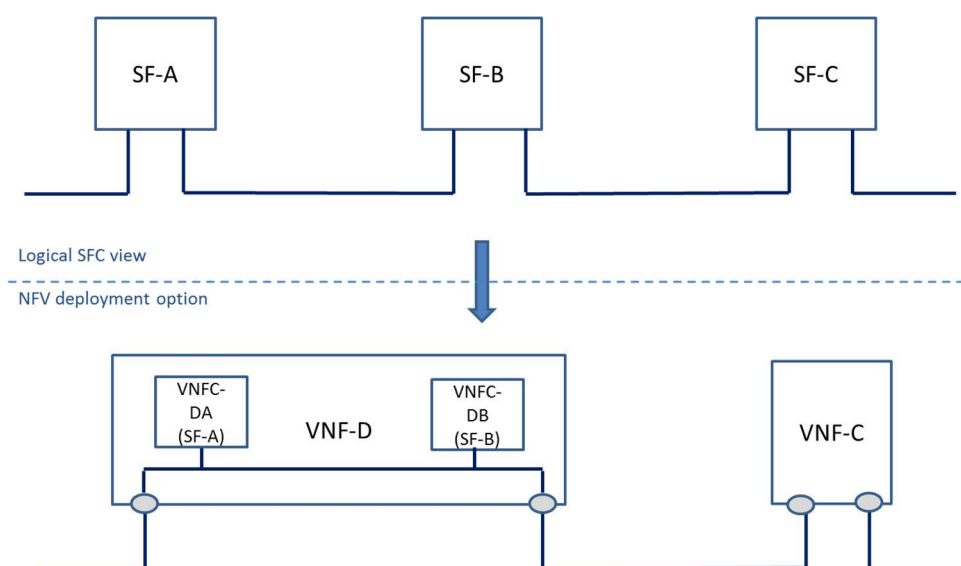

Figure A.4-2: Many-to-one mapping

Figure A.4-3 illustrates the case where one SF is implemented as two VNFs.

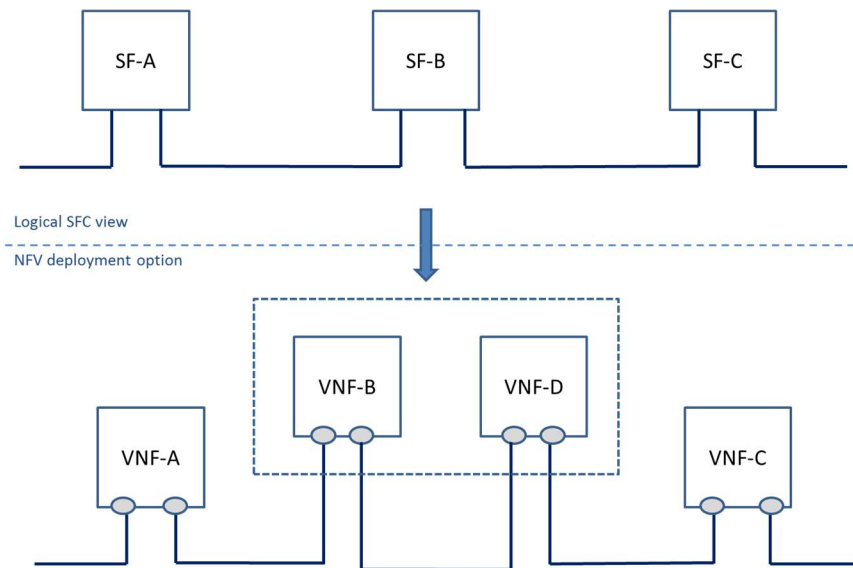

Figure A.4-3: One-to-many mapping

Figure A.4-4 illustrates the case where one SF is implemented as two VNFs grouped as a nested NS. In that case only the SAPs of the nested NS are visible in the NFPD of the parent NS.

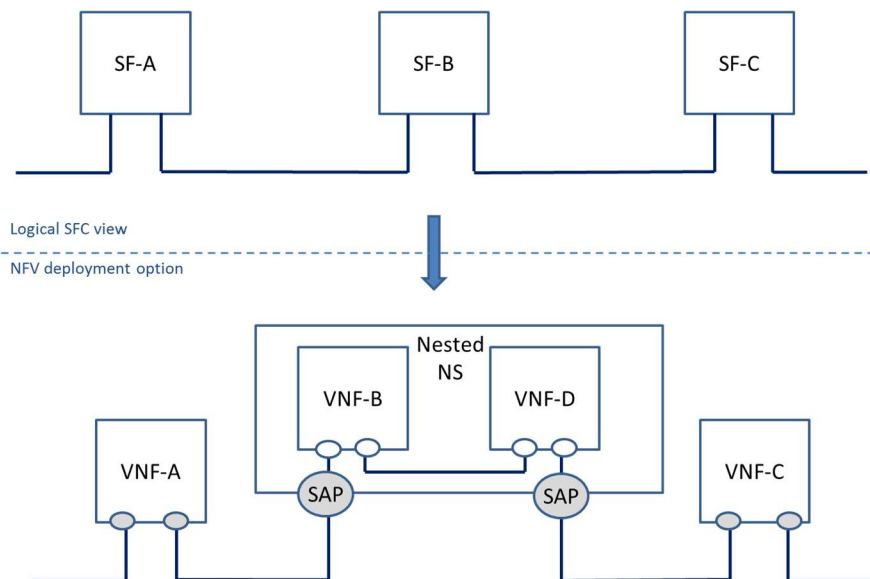

Figure A.4-4: SF as a nested NS mapping

Annex B (informative): Example of L2_NETWORK scope used in AffinityOrAntiAffinityGroup

B.1 Introduction

This annex illustrates the use cases of designing the AffinityOrAntiAffinityGroup in the NSD to express the layer 2 network isolation requirement.

B.2 Use case: AffinityOrAntiAffinityGroup defined in NsVirtualLinkConnectivity

B.2.1 Network topology

For the purposes of describing this use case, figure B.2.1-1 illustrates an example of connectivity of three VNF instances. In this example, VNF_1, VNF_2 and VNF_3 are connected to the same VL instance, which contains two different underlying L2 networks. VNF_1 and VNF_2, each connected to the two different L2 networks, VNF_3 has two VnfExtCp(s), and each connected to the different L2 networks.

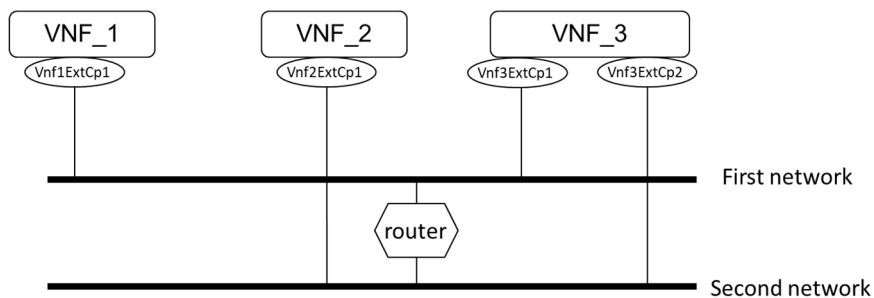

Figure B.2.1-1: VNFs connect to the same VL instance with different L2 network connectivity

B.2.2 NSD representation

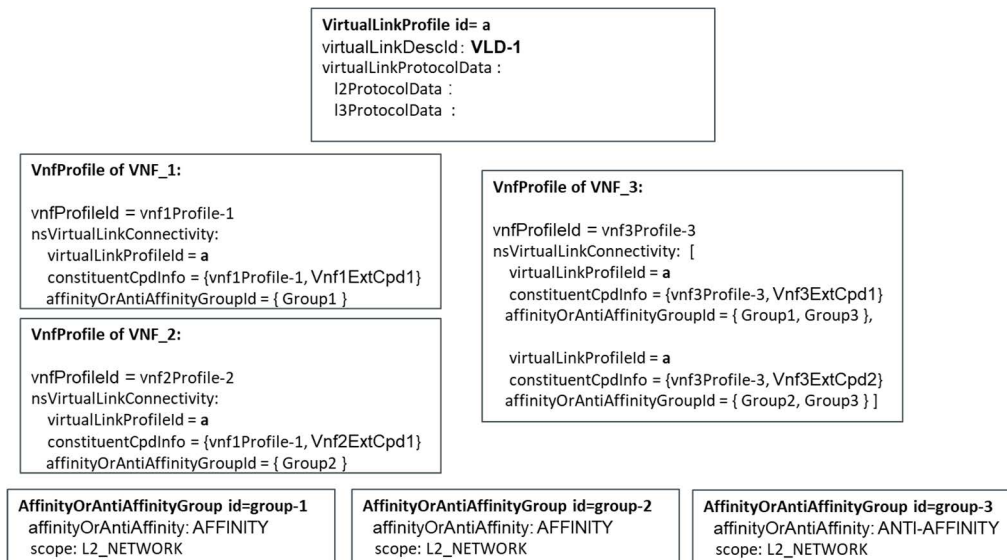

Figure B.2.2-1: NSD example with AffinityOrAntiAffinityGroup defined in NsVirtualLinkConnectivity

Figure B.2.2-1 shows the related descriptors in the NSD. There are 3 VNFs, VNF_1, VNF_2 and VNF_3, all connect to the same virtual link.

- One VirtualLinkProfile with id a.
- VnfProfile of VNF_1 contains nsVirtualLinkConnectivity with VirtualLinkProfile a and Vnf1ExtCpd1, and associates with Group1 as AffinityOrAntiAffinityGroup.
- VnfProfile of VNF_2 contains nsVirtualLinkConnectivity with VirtualLinkProfile a and Vnf2ExtCpd1, and associates with Group2 as AffinityOrAntiAffinityGroup.
- VnfProfile of VNF_3 contains 2 occurrences of nsVirtualLinkConnectivity, one with VirtualLinkProfile a and Vnf3ExtCpd1, and associates with Group1 and Group3 as AffinityOrAntiAffinityGroup; another one with VirtualLinkProfile a and Vnf3ExtCpd2, and associates with Group2 and Group3 as AffinityOrAntiAffinityGroup.
- AffinityOrAntiAffinityGroups Group1 and Group2 are AFFINITY group with L2_NETWORK scope, while Group3 is an ANTI_AFFINITY group with L2_NETWORK scope.

B.2.3 NS instantiation

For the actual NS instantiation, the NFVO creates the NS virtual link based on the VirtualLinkProfile and the AffinityOrAntiAffinityGroup information described in the NSD:

- Group1 indicates to the NFVO the requirement that the connection point of VNF_1 and VNF_3 is expected to connect to a first network. Group2 indicates to the NFVO the requirement that the connection point of VNF_2 and the other connection point of VNF_3 is expected to connect to a second network. And finally, Group3 indicates that the first network and the second network are expected not to share the same layer 2 NFVI resource.
- To fulfil the interconnectivity within the NS VL, the NFVO requests the allocation (through Or-Vi reference point as specified in ETSI GS NFV-IFA 005 [1.7]) of two virtualised network resources and a routing resource used to establish the connection between the two virtualised networks.

Annex C (informative): Change History

Date	Version	Information about changes
27-06-2017	2.1.2	Update with CRs NFVIFA(17)000487, NFVIFA(17)000575
08-12-2017	2.3.2	Update with CRs: NFVIFA(17)000658r10 NFVIFA(17)000761 NFVIFA(17)000818r2 NFVIFA(17)000937r4 NFVIFA(17)000942 NFVIFA(17)000950 NFVIFA(17)000955 NFVIFA(17)000963 NFVIFA(17)000979 NFVIFA(17)001006 NFVIFA(17)001041r1 NFVIFA(17)001099r2 NFVIFA(17)001143
12-04-2018	2.4.2	NFVIFA(18)000304
08-05-2018	2.4.3	NFVIFA(18)000192r1 NFVIFA(18)000193
22-06-2018	2.4.4	Rapporteur action: Bug Tracker 7727, editorial review NFVIFA(18)000373r3 NFVIFA(18)000503 NFVIFA(18)000379r3
12-09-2018	3.1.2	Creation of first draft version for 2018H2 maintenance
25-09-2018	3.1.2	Update wit CRs: NFVIFA(18)000791r2_IFA014_release_3_mirror_deleting_Cpd_and_reference_the_Cpd_i
12-11-2018	3.1.3	Update wit CRs: NFVIFA(18)000885r1 NFVIFA(18)000927r1 NFVIFA(18)000973 NFVIFA(18)000974
10-12-2018	3.1.4	Update wit CRs: NFVIFA(18)0001026 NFVIFA(18)0001051 NFVIFA(18)0001095 Rapporteur action: replace "a NSD" with "an NSD", replace "note 1" with "note" in table 6.2.8.2-1
07-02-2019	3.1.5	Update with CRs: NFVIFA(18)000653r4 NFVIFA(18)0001113r2 (renumber i.6 to i.8; renumber notes in table 5.3-1 for consistency with NFVIFA(18)000653r4) NFVIFA(19)000122 Rapporteur action: harmonize (see note x) to See note x.; replace "a NS" with "an NS".
26-02-2019	3.1.6	Update with CR: NFVIFA(19)000131r3
02-04-2019	3.2.2	Creation of first draft version for 2019H1 maintenance. Update with CR: NFVIFA(19)000263
27-05-2019	3.2.3	Update with CRs: Rapporteur action: correct content column for the names divided into two lines. NFVIFA(19)000387r2_IFA014Ed331__Re3mirror_- _Improving_consistency_in_NFP_data_t NFVIFA(19)000418r1_IFA014Ed331__Additional_corrections_for_CpdInConstituentEle NFVIFA(19)000432r4_IFA014Ed331_Re3mirror_CpPool_in_VNFFG

Date	Version	Information about changes
16-07-2019	3.2.4	Update with CRs: NFVIFA(19)000514r2_IFA014_Rel_3_mirror_NfpPositionDesc_and_NfpPositionElement NFVIFA(19)000549_IFA014ed331_Rel-3_mirror_ONAP_alignment_Class_VirtualLinkD NFVIFA(19)000598r2_IFA014Ed331_Re3mirror_Additional_Parameters_NSD NFVIFA(19)000628_IFA014ed331_Rel3Mirror_6_5_5_LinkBitrateRequirements_IE NFVIFA(19)000630_IFA014ed331_Rel3Mirror_6_3_8_LocalAffinityOrAntiAffinityRul (Rapporteur action: remove word "whether" from description of attribute scope in table 6.3.8.2-1) NFVIFA(19)000706_IFA014ed331v324_editorial_review NFVIFA(19)000526r6_IFA014_MegaCR_FEAT16_SAL
02-10-2019	3.3.2	Creation of first draft version for 2019H2 maintenance. Rapporteur actions: <ul style="list-style-type: none"> Add missing space in table 6.3.11.2-1 in content column for affinityOrAntiAffinityGroupId Removing spare line break in table 6.6.2.2-1 in attribute column for geographicalLocation Info
02-10-2019	3.3.3	Update with CR: NFVIFA(19)000810_IFA014ed341_Improving_nsProfile_attribute_description_in_tab
16-12-2019	3.3.4	Update with CRs: NFVIFA(19)000864r3_IFA014_-_VirtualLinkProtocolData_is_missing_in_VirtualLinkPr NFVIFA(19)000894_IFA014-Remove_Annex_-_Authors_and_contributors NFVIFA(19)000935_IFA014-Various_corrections
25-03-2020	3.3.5	Update with CRs: NFVIFA(19)000996_IFA014_Improve_wording_left_for_protocol_design_stage NFVIFA(20)000177r1_IFA014ed341_fix_Enum_values NFVIFA(20)000201r1_IFA014ed341_fix_Sapd_attribute_associatedCpd
29-04-2020	3.3.6	Update with CRs: NFVIFA(20)000276_IFA014ed341-IFA015_harmonization_corrections NFVIFA(20)000290_IFA014ed341-IFA015_harmonization_corrections_set2 Rapporteur actions: <ul style="list-style-type: none"> Correction in table 6.4.6.2-1 of wrong implementation of NFVIFA(19)000387r2_IFA014Ed331_Re3mirror_-_Improving_consistency_in_NFP_data_t : attribute name nfpPositionElement should be nfpPositionElementId. Harmonization of description of attributes with content "Identifier (Reference to)" in tables 6.2.7.2-1, 6.3.2.2-1, 6.3.3.2-1, 6.3.4.2-1, 6.3.10.2-1, 6.3.11.2-1, 6.7.4.2-1, 6.7.5.2-1, 6.7.6.2-1. Editorial correction in table 6.3.3.2-1: vnfProfile > VnfProfile in description column.
18-06-2020	4.0.1	Release 4 baseline version created from published version v3.4.1
21-09-2020	4.0.2	Update with CRs: NFVIFA(20)000481_IFA014ed411_Dependencies_IE_description_improvement
25-02-2021	4.0.3	Update with CRs: NFVIFA(20)000842r3_ENH02_05_IFA014ed421_Adding_support_of_flexible_NS_insta ntia NFVIFA(21)000039r4_IFA014ed421_rel_4_mirror_clarification_for_I2ProtocolData
19-03-2021	4.0.4	Update with CRs: NFVIFA(21)000150r4_Enh02_01_IFA014_add_new_scope_for_AffinityOrAntiAffinityGro u NFVIFA(21)000180_Enh02_04-IFA014ed421_MegaCR NFVIFA(21)000205r1_IFA014ed421_MegaCR_FEAT17_Cloud-native_VNFs NFVIFA(21)000210_IFA014ed421_6_3_10_Removal_of_NsScaleInfo

History

Document history		
V4.2.1	May 2021	Publication