



GROUP SPECIFICATION

Fifth Generation Fixed Network (F5G); F5G Advanced Technology Requirements and Gap Analyses; Release 4

Disclaimer

The present document has been produced and approved by the Fifth Generation Fixed Network (F5G) ETSI Industry Specification Group (ISG) and represents the views of those members who participated in this ISG.
It does not necessarily represent the views of the entire ETSI membership.

Reference

DGS/F5G-0033

KeywordsF5G, F5G Advanced, fibre, optical, PON,
requirements**ETSI**650 Route des Lucioles
F-06921 Sophia Antipolis Cedex - FRANCE

Tel.: +33 4 92 94 42 00 Fax: +33 4 93 65 47 16

Siret N° 348 623 562 00017 - APE 7112B
Association à but non lucratif enregistrée à la
Sous-Préfecture de Grasse (06) N° w061004871

Important notice

The present document can be downloaded from the
[ETSI Search & Browse Standards](#) application.

The present document may be made available in electronic versions and/or in print. The content of any electronic and/or print versions of the present document shall not be modified without the prior written authorization of ETSI. In case of any existing or perceived difference in contents between such versions and/or in print, the prevailing version of an ETSI deliverable is the one made publicly available in PDF format on [ETSI deliver](#) repository.

Users should be aware that the present document may be revised or have its status changed,
this information is available in the [Milestones listing](#).

If you find errors in the present document, please send your comments to
the relevant service listed under [Committee Support Staff](#).

If you find a security vulnerability in the present document, please report it through our
[Coordinated Vulnerability Disclosure \(CVD\)](#) program.

Notice of disclaimer & limitation of liability

The information provided in the present deliverable is directed solely to professionals who have the appropriate degree of experience to understand and interpret its content in accordance with generally accepted engineering or other professional standard and applicable regulations.

No recommendation as to products and services or vendors is made or should be implied.

No representation or warranty is made that this deliverable is technically accurate or sufficient or conforms to any law and/or governmental rule and/or regulation and further, no representation or warranty is made of merchantability or fitness for any particular purpose or against infringement of intellectual property rights.

In no event shall ETSI be held liable for loss of profits or any other incidental or consequential damages.

Any software contained in this deliverable is provided "AS IS" with no warranties, express or implied, including but not limited to, the warranties of merchantability, fitness for a particular purpose and non-infringement of intellectual property rights and ETSI shall not be held liable in any event for any damages whatsoever (including, without limitation, damages for loss of profits, business interruption, loss of information, or any other pecuniary loss) arising out of or related to the use of or inability to use the software.

Copyright Notification

No part may be reproduced or utilized in any form or by any means, electronic or mechanical, including photocopying and microfilm except as authorized by written permission of ETSI.

The content of the PDF version shall not be modified without the written authorization of ETSI.

The copyright and the foregoing restriction extend to reproduction in all media.

© ETSI 2026.
All rights reserved.

Contents

Intellectual Property Rights	11
Foreword.....	11
Modal verbs terminology.....	11
1 Scope	12
2 References	12
2.1 Normative references	12
2.2 Informative references.....	14
3 Definition of terms, symbols and abbreviations.....	17
3.1 Terms.....	17
3.2 Symbols.....	17
3.3 Abbreviations	17
4 F5G-A Technology requirements and landscape for Release 3 use cases.....	20
4.1 Overview	20
4.1.1 Introduction.....	20
4.1.2 Document structure overview	21
4.2 Premium private line service automation	22
4.2.1 Use Case Briefing	22
4.2.2 Technology Requirements and Gap Analyses	22
4.2.2.1 General.....	22
4.2.2.2 Automatic evaluation of private line SLA before provisioning	22
4.2.2.3 Agile service provisioning	22
4.2.2.4 CPE plug-and-play	22
4.2.2.5 Bandwidth on Demand.....	23
4.2.2.6 Real-time visualization of private line SLAs	23
4.2.3 Current related standard specifications	23
4.2.3.1 ITU-T	23
4.2.3.2 IETF	24
4.3 Stable & reliable Wi-Fi® connection over on-premises networking	24
4.3.1 Use Case Briefing	24
4.3.2 Technology Requirements and Gap Analyses	25
4.3.2.1 General.....	25
4.3.2.2 Service type identification and adaptation	25
4.3.2.3 Wi-Fi® interference recognition and avoidance	25
4.3.2.4 Provide latency sensitive transmission mechanism.....	26
4.3.2.5 Enable seamless connection switching.....	26
4.3.3 Current related standard specifications	27
4.3.3.1 ITU-T	27
4.3.3.2 IEEE.....	28
4.4 Computing collaboration in PON network.....	28
4.4.1 Use Case Briefing	28
4.4.2 Technology Requirements and Gap Analyses	29
4.4.2.1 General.....	29
4.4.2.2 Heterogeneous computing capability	29
4.4.2.3 Identification of service flow & corresponding demand.....	29
4.4.2.4 Dynamic collaboration between the PON network elements and the computing elements	29
4.4.3 Current related standard specifications	30
4.4.3.1 ITU-T	30
4.4.3.2 BBF.....	31
4.5 Intelligent power grid	31
4.5.1 Use Case Briefing	31
4.5.2 Technology Requirements and Gap Analyses	31
4.5.2.1 General.....	31
4.5.2.2 High capacity optical transport network	32
4.5.2.3 Fine grain optical transport network	32

4.5.2.4	End-to-end high-quality connection.....	33
4.5.3	Current related standard specifications	34
4.5.3.1	ITU-T	34
4.5.3.2	IEEE.....	36
4.6	Railway perimeter inspection.....	36
4.6.1	Use Case Briefing	36
4.6.2	Technology Requirements and Gap Analyses	36
4.6.2.1	General	36
4.6.2.2	Fibre sensing performance	36
4.6.3	Current related standard specifications	37
4.6.3.1	ITU-T	37
4.7	Naked-eye 3D display	37
4.7.1	Use Case Briefing	37
4.7.2	Technology Requirements and Gap Analyses	37
4.7.2.1	General.....	37
4.7.2.2	Extremely high throughput	38
4.7.2.3	Latency restricted transmission.....	38
4.7.3	Current related standard specifications	38
4.7.3.1	ITU-T SG15	38
4.8	Unified access and on-premises network	38
4.8.1	Use Case Briefing	38
4.8.2	Technology Requirements and Gap Analyses	39
4.8.2.1	General	39
4.8.2.2	Provide unified control of data transmission.....	39
4.8.2.3	Provide unified management of the whole system.....	39
4.8.3	Current related standard specifications	40
4.8.3.1	ITU-T SG15	40
4.8.3.2	ETSI ISG F5G.....	40
4.9	OTN intelligent fault management.....	41
4.9.1	Use Case Briefing	41
4.9.2	Technology Requirements and Gap Analyses	41
4.9.2.1	General	41
4.9.2.2	OTN alarm aggregation.....	41
4.9.2.3	Troubleshooting	42
4.9.2.4	Fault impact analysis.....	42
4.9.2.5	Report of incident information.....	42
4.9.3	Current related standard specifications	43
4.9.3.1	ITU.....	43
4.9.3.2	IETF.....	43
4.10	Evaluation and assurance of user service experience	43
4.10.1	Use Case Briefing	43
4.10.2	Technology Requirements and Gap Analyses	44
4.10.2.1	General.....	44
4.10.2.2	Evaluation of user's service experience.....	44
4.10.2.3	User experience demarcation and root cause analysis	44
4.10.2.4	User experience rectification and audit.....	45
4.10.3	Current related standard specifications	46
4.10.3.1	BBF.....	46
4.10.3.2	ETSI.....	46
4.11	Cloud Desktop.....	46
4.11.1	Use Case Briefing	46
4.11.2	Technology Requirements and Gap Analyses	46
4.11.2.1	General	46
4.11.2.2	Edge cloud infrastructure	46
4.11.2.3	Enable intelligence in the network.....	47
4.11.2.4	Shallow compression techniques	47
4.12	Dynamically digitalized ODN.....	48
4.12.1	Use Case Briefing	48
4.12.2	Technology Requirements and Gap Analyses	48
4.12.2.1	General.....	48
4.12.2.2	Dynamically visualization of ODN.....	48
4.12.2.3	Proactively diagnostic and remote fault location	49

4.12.2.4	ODN resource management	49
4.12.3	Current related standard specifications	49
4.12.3.1	Current ODN related standards	49
4.13	On-premises Millimetre-Wave (mmWave) WLAN	49
4.13.1	Use Case Briefing	49
4.13.2	Technology Requirements and Gap Analyses	50
4.13.2.1	General	50
4.13.2.2	Provide necessary throughput to support F5G-A applications	50
4.13.2.3	Well controlled Wi-Fi® signals to support interference free connection	50
4.13.2.4	Coordination with sub-6 G Wi-Fi®	51
4.13.3	Current related standard specifications	51
4.13.3.1	ITU-T SG15	51
4.13.3.2	IEEE 802.11	52
4.14	Wavelength-shared WDM Aggregation Network (AGGN)	52
4.14.1	Use Case Briefing	52
4.14.2	Technology Requirements and Gap Analyses	52
4.14.2.1	Network bandwidth	52
4.14.2.2	Multiple-ring network and long-haul transmission distance	53
4.14.2.3	Flexible grooming capability	53
4.14.2.4	Automatic network O&M	54
4.14.3	Current related standard specifications	55
4.14.3.1	ITU-T	55
4.14.3.2	ETSI	55
4.14.3.3	IEEE	55
4.14.3.4	OIF	55
4.15	Robotics as a Service	55
4.15.1	Use Case Briefing	55
4.15.2	Technology Requirements and Gap Analyses	55
4.15.2.1	General	55
4.15.2.2	Latency	55
4.15.2.3	Cable Requirements	56
4.15.2.4	Ease of Installation	57
4.15.2.5	Integration of F5G-A networks with ROS and DDS	57
4.15.3	Current related standard specifications	57
4.15.3.1	Cable Specifications	57
4.15.3.2	Data Distribution Service (DDS)	57
4.16	All-optical base for urban rail transit communication network	58
4.16.1	Use Case Briefing	58
4.16.2	Technology Requirements and Gap Analyses	59
4.16.2.1	General	59
4.16.2.2	All-optical network base communication network for urban rail transit network	60
4.16.3	Current related standard specifications	61
4.16.3.1	ITU-T	61
4.16.3.2	IEEE	61
4.17	Optical Fibre sensing for telecom operators	62
4.17.1	Use Case Briefing	62
4.17.2	Technology Requirements and Gap Analyses	62
4.17.2.1	General	62
4.17.3	Current related standard specifications	63
4.17.3.1	ITU-T	63
4.18	QoD App-Flow service provisioning	64
4.18.1	Use Case Briefing	64
4.18.2	Technology Requirements and Gap Analyses	64
4.18.2.1	General	64
4.18.3	Current related standard specifications	66
4.18.3.1	CAMARA	66
4.18.3.2	ITU-T QoS in PON and G.fin	66
4.18.3.3	ETSI ISG F5G Telemetry	66
5	F5G-A Technology requirements and landscape for Release 4 use cases	66
5.1	Overview	66
5.1.1	Introduction	66

5.1.2	Document structure overview	67
5.2	Smart Hospital	67
5.2.1	Use Case Briefing	67
5.2.2	Technology Requirements and Gap Analyses	67
5.2.2.1	General	67
5.2.2.2	Optical network layer	68
5.2.2.3	Network architecture and security	68
5.2.2.4	Network management system (NMS)	69
5.2.3	Current related standard specifications	69
5.2.3.1	ITU-T (International Telecommunication Union)	69
5.2.3.2	IEC (International Electrotechnical Commission)	69
5.2.3.3	IEEE (Institute of Electrical and Electronics Engineers)	69
5.2.3.4	IETF (Internet Engineering Task Force)	69
5.3	Energy-efficiency by deactivating low-load ports	70
5.3.1	Use Case Briefing	70
5.3.2	Technology Requirements and Gap Analyses	70
5.3.2.1	General	70
5.3.2.2	Energy and Load Monitor	70
5.3.2.3	Traffic Analyser	71
5.3.2.4	Decision Engine	71
5.3.2.5	Execution Engine	71
5.3.2.6	Port Manager	72
5.3.2.7	Path Availability	72
5.3.2.8	Traffic Rerouting	73
5.3.2.9	Device Capabilities	73
5.3.3	Current related standard specifications	73
5.3.3.1	IETF	73
5.3.3.2	OpenConfig	74
5.4	Cloud-based Object Wave Transmissions	74
5.4.1	Use Case Briefing	74
5.4.2	Technology Requirements and Gap Analyses	74
5.4.2.1	General	74
5.4.2.2	Computing and Storage Requirements	74
5.4.2.3	Network Requirements	75
5.4.2.4	Control and Management Requirements	75
5.4.3	Current related standard specifications	76
5.4.3.1	ITU-T SG21	76
5.5	P2MP fgOTN for premium private lines	76
5.5.1	Use Case Briefing	76
5.5.2	Technology Requirements and Gap Analyses	76
5.5.2.1	General	76
5.5.2.2	fgOTN over P2MP network	76
5.5.3	Current related standard specifications	77
5.5.3.1	ITU-T	77
5.6	Smart Sensor Cloud for AI in Industrial Manufacturing	78
5.6.1	Use Case Briefing	78
5.6.2	Technology Requirements and Gap Analyses	78
5.6.2.1	General	78
5.6.2.2	Latency	78
5.6.2.3	Bandwidth	78
5.6.2.4	Security	79
5.6.3	Current related standard specifications	79
5.7	Integrated NAS over FTTR	79
5.7.1	Use Case Briefing	79
5.7.2	Technology Requirements and Gap Analyses	79
5.7.2.1	General	79
5.7.2.2	Reliability of user's data on NAS	80
5.7.2.3	Security	80
5.7.2.4	High performance for the network access	80
5.7.3	Current related standard specifications	81
5.7.3.1	ITU-T	81
5.7.3.2	CCSA	82

5.7.3.3	ETSI	82
5.8	Generating an Energy Map for sustainable F5G-Advanced networks infrastructure	83
5.8.1	Use Case Briefing	83
5.8.2	Technology Requirements and Gap Analyses	83
5.8.2.1	General	83
5.8.2.2	Energy Watcher.....	83
5.8.2.3	Energy Cost Calculator	84
5.8.3	Current related standard specifications	85
5.8.3.1	IETF	85
5.8.3.2	OpenConfig	85
5.8.3.3	ITU-T	86
5.9	Flat wheel detection using Distributed Acoustic Sensing (DAS).....	86
5.9.1	Use Case Briefing	86
5.9.2	Technology Requirements and Gap Analyses	86
5.9.2.1	General	86
5.9.2.2	Detection Latency	86
5.9.2.3	Localization accuracy.....	87
5.9.2.4	Detection sensitivity.....	87
5.9.2.5	Data Throughput	87
5.9.2.6	Availability / uptime	87
5.9.2.7	Environmental robustness	87
5.9.2.8	Networking delay tolerance	87
5.9.2.9	Integration	88
5.10	Integrated RFID over FTTR.....	88
5.10.1	Use Case Briefing	88
5.10.2	Technology Requirements and Gap Analyses	88
5.10.2.1	General	88
5.10.2.2	Low latency channel for exchanging RFID protocol message.....	88
5.10.2.3	High accuracy of frequency and time synchronization for distributed beamforming	89
5.10.2.4	Coordinated control and management for integrated RFID over FTTR	89
5.10.3	Current related standard specifications	90
5.10.3.1	ISO/IEC 18000-63: The Global Benchmark of RFID.....	90
5.10.3.3	ITU-T SG15	90
5.11	AI-Powered Intelligent Flash Disconnection Fault Localization in Optical Network.....	91
5.11.1	Use Case Briefing	91
5.11.2	Technology Requirements and Gap Analyses	91
5.11.2.1	General	91
5.11.2.2	Flash disconnection fault localization performance	91
5.11.3	Current related standard specifications	92
5.11.3.1	ITU-T	92
5.12	3D video enabling via FTTR.....	92
5.12.1	Use Case Briefing	92
5.12.2	Technology Requirements and Gap Analyses	92
5.12.2.1	General	92
5.12.2.2	Enable AI assisted 2D-to-3D real-time video transformation	93
5.12.2.3	Provide accurate synchronization between FTTR devices and 3D glasses	93
5.12.2.4	Provide enough the frame rate for 3D view experience	93
5.12.2.5	Enable management and control of 3D glasses and FTTR system	94
4.12.3	Current related standard specifications	94
4.12.3.1	ITU-T SG15	94
5.13	Optical cable Co-route detection based on DFOS technology combined with AI capability.....	94
5.13.1	Use Case Briefing	94
5.13.2	Technology Requirements and Gap Analyses	95
5.13.2.1	General	95
5.13.2.2	Optical cable Co-route detection performance.....	95
5.13.3	Current related standard specifications	96
5.13.3.1	ITU-T	96
5.14	Generative AI for F5G-A Network Management Tasks	96
5.14.1	Use Case Briefing	96
5.14.2	Technology Requirements and Gap Analyses	96
5.14.2.1	General	96
5.14.2.2	Context Management and Data Availability	96

5.14.2.3	Code Generation and Validation	97
5.14.2.4	Operational Safety and Privacy.....	97
5.14.3	Current related standard specifications	97
5.14.3.1	OpenConfig	97
5.14.3.2	ETSI ISG F5G - Telemetry Framework and Requirements for Access Networks.....	97
5.15	Distributed Intelligence with Privacy-Preserving Features for FTTR.....	98
5.15.1	Use Case Briefing	98
5.15.2	Technology Requirements and Gap Analyses	98
5.15.2.1	General	98
5.15.2.2	Heterogeneous computing capability	98
5.15.2.3	Identification of Service Flow Type and Demand for Dynamic QoS	99
5.15.2.4	Dynamic Telemetry Data Streaming from SFUs and MFU	99
5.15.2.5	Power Consumption Metrics as KPI for Green ICT Enabling	99
5.15.2.6	AI Model Orchestration and Management	100
5.15.2.7	Privacy and GDPR Compliance	100
5.15.2.8	Interoperability and Standardization Across Vendors.....	100
5.15.3	Current related standard specifications	100
5.15.3.1	ITU-T	100
5.15.3.2	ETSI	101
6	Technology Landscape Summary	101
	History	119

List of Figures

Figure 1: Centralized fibre and wireless coordination architecture (Source: Recommendation ITU-T G.9940 [7])	27
Figure 2: Protocol stack of G.fin DLL (Source: Recommendation ITU-T G.9942 [9]).....	28
Figure 3: An example of management scheme of FTTR (Source: Recommendation ITU-T G.9940 [7]).....	31
Figure 4: Overview of the OTN structure	34
Figure 5: Overview of the fgOTN layer network inside OTN	35
Figure 6: The information structure of the fgOTN layer network.....	35
Figure 7: Incident-based fault management (Source: ETSI GR F5G 020 [i.1]).....	41
Figure 8: Overview of the F5G-A Residential broadband QoE evaluation and assurance (Source: ETSI GR F5G 020 [i.1]).....	44
Figure 9: An example of mmWave WLAN network	50
Figure 10: Wavelength-shared AGGN configuration.....	53
Figure 11: Overview of urban rail transit communication system (Source: ETSI GR F5G 020 [i.1]).....	59
Figure 12: ITU-T G.dfos scope	63
Figure 13: Overview of fgOTN over P2MP network.....	76
Figure 14: Data channel encryption of FTTR system in Recommendation ITU-T G.9942 [9].....	81
Figure 15: PON and FTTR collaboration management in ITU-T G.Sup89 [i.62].....	82
Figure 16: Layout of the cable conduit and placement of optical fibres used for telecommunication	86
Figure 17: The scenario of 3D video enabling via FTTR.....	92

List of Tables

Table 1: Maximum transmission latency of RFID corresponding to different BLF	89
Table 2: Summary of Requirements and Gaps	101
Table 3: Suggested actions for identified gaps	113

Intellectual Property Rights

Essential patents

IPRs essential or potentially essential to normative deliverables may have been declared to ETSI. The declarations pertaining to these essential IPRs, if any, are publicly available for **ETSI members and non-members**, and can be found in ETSI SR 000 314: "*Intellectual Property Rights (IPRs); Essential, or potentially Essential, IPRs notified to ETSI in respect of ETSI standards*", which is available from the ETSI Secretariat. Latest updates are available on the [ETSI IPR online database](#).

Pursuant to the ETSI Directives including the ETSI IPR Policy, no investigation regarding the essentiality of IPRs, including IPR searches, has been carried out by ETSI. No guarantee can be given as to the existence of other IPRs not referenced in ETSI SR 000 314 (or the updates on the ETSI Web server) which are, or may be, or may become, essential to the present document.

Trademarks

The present document may include trademarks and/or tradenames which are asserted and/or registered by their owners. ETSI claims no ownership of these except for any which are indicated as being the property of ETSI, and conveys no right to use or reproduce any trademark and/or tradename. Mention of those trademarks in the present document does not constitute an endorsement by ETSI of products, services or organizations associated with those trademarks.

DECT™, **PLUGTESTS™**, **UMTS™** and the ETSI logo are trademarks of ETSI registered for the benefit of its Members. **3GPP™**, **LTE™** and **5G™** logo are trademarks of ETSI registered for the benefit of its Members and of the 3GPP Organizational Partners. **oneM2M™** logo is a trademark of ETSI registered for the benefit of its Members and of the oneM2M Partners. **GSM®** and the GSM logo are trademarks registered and owned by the GSM Association.

Foreword

This Group Specification (GS) has been produced by ETSI Industry Specification Group (ISG) Fifth Generation Fixed Network (F5G).

Modal verbs terminology

In the present document "**shall**", "**shall not**", "**should**", "**should not**", "**may**", "**need not**", "**will**", "**will not**", "**can**" and "**cannot**" are to be interpreted as described in clause 3.2 of the [ETSI Drafting Rules](#) (Verbal forms for the expression of provisions).

"**must**" and "**must not**" are **NOT** allowed in ETSI deliverables except when used in direct citation.

1 Scope

The present document specifies the technology requirements for F5G-A use cases releases 3 and 4, and explores existing technologies from related SDOs. The present document performs gap analyses between the technologies required by the use cases and those that are available. The identification of the relevant SDOs is based on their existing projects.

2 References

2.1 Normative references

References are either specific (identified by date of publication and/or edition number or version number) or non-specific. For specific references, only the cited version applies. For non-specific references, the latest version of the referenced document (including any amendments) applies.

Referenced documents which are not found to be publicly available in the expected location might be found in the [ETSI docbox](#).

NOTE: While any hyperlinks included in this clause were valid at the time of publication, ETSI cannot guarantee their long-term validity.

The following referenced documents are necessary for the application of the present document.

- [1] [Recommendation ITU-T G.709/Y.1331](#): "Interfaces for the optical transport network".
- [2] [Recommendation ITU-T G.709.20](#): "Overview of fine grain OTN".
- [3] [ETSI GS F5G 014](#): "Fifth Generation Fixed Network (F5G); F5G Network Architecture Release 2".
- [4] [IEEE 802.11kTM-2008](#): "IEEE Standard for Information technology -- Local and metropolitan area networks-- Specific requirements-- Part 11: Wireless LAN Medium Access Control (MAC) and Physical Layer (PHY) Specifications Amendment 1: Radio Resource Measurement of Wireless LANs".
- [5] [IEEE 802.11vTM-2011](#): "IEEE Standard for Information technology -- Local and metropolitan area networks-- Specific requirements-- Part 11: Wireless LAN Medium Access Control (MAC) and Physical Layer (PHY) specifications Amendment 8: IEEE 802.11 Wireless Network Management".
- [6] [IEEE 802.11rTM-2008](#): "IEEE Standard for Information technology -- Local and metropolitan area networks-- Specific requirements-- Part 11: Wireless LAN Medium Access Control (MAC) and Physical Layer (PHY) Specifications Amendment 2: Fast Basic Service Set (BSS) Transition".
- [7] [Recommendation ITU-T G.9940 \(12/2023\)](#): "High speed fibre-based in-premises transceivers - system architecture".
- [8] [Recommendation ITU-T G.9941 \(07/2024\)](#): "High speed fibre-based in-premises transceivers - physical layer specification".
- [9] [Recommendation ITU-T G.9942 \(07/2024\)](#): "High speed fibre-based in-premises transceivers - Data link layer".
- [10] [Recommendation ITU-T G.988 \(11/2022\)](#): "ONU management and control interface (OMCI) specification".
- [11] [ETSI GS F5G 013](#): "Fifth Generation Fixed Network (F5G); F5G Technology Landscape Release 2".
- [12] [Recommendation ITU-T G.709.1/Y.1331.1](#): "Flexible OTN common elements", consented in the ITU-T SG15 Plenary Meeting, 20 November - 1 December, 2023.

- [13] [Recommendation ITU-T G.709.3](#): "Flexible OTN B100G long-reach interfaces".
- [14] [Recommendation ITU-T G.709.5](#): "Flexible OTN short-reach interfaces".
- [15] [Recommendation ITU-T G.709.6](#): "Flexible OTN B400G long-reach interfaces".
- [16] [Recommendation ITU-T G.872](#): "Architecture of the optical transport network".
- [17] [IEEE P2893™-2023](#): "IEEE Approved Draft Standard for Flexible Optical Service Unit (OSUFlex) of Optical Transport Network (OTN) in Power Systems".
- [18] [Recommendation ITU-T G.823](#): "The control of jitter and wander within digital networks which are based on the 2048 kbit/s hierarchy".
- [19] [Recommendation ITU-T G.825](#): "The control of jitter and wander within digital networks which are based on the synchronous digital hierarchy (SDH)".
- [20] [Recommendation ITU-T G.874 \(10/2020\)](#): "Management aspects of optical transport network elements".
- [21] [ETSI GS F5G 015 \(V1.2.1\)](#): "Fifth Generation Fixed Network (F5G); F5G Residential Services Quality Evaluation and Classification Release 2".
- [22] [ETSI GS F5G 017 \(V1.1.1\)](#): "Fifth Generation Fixed Network (F5G); F5G Measurement Specification for Residential Services Quality Evaluation".
- [23] [ETSI GS F5G 026 \(V1.1.1\)](#): "Fifth Generation Fixed Network (F5G); Architecture and data models for residential service quality monitoring".
- [24] [ISO/IEC 14496-10:2025](#): "Information technology — Coding of audio-visual objects — Part 10: Advanced video coding".
- [25] [Recommendation ITU-T G.698.2](#): "Amplified multichannel dense wavelength division multiplexing applications with single channel optical interfaces".
- [26] [IEEE 802.3™-2022](#): "IEEE standards for Ethernet".
- [27] [OIF-400ZR-01.0 March 10th 2020](#): "Implementation Agreement 400ZR".
- [28] [Recommendation ITU-T G.672](#): "Characteristics of multi-degree reconfigurable optical add/drop multiplexers".
- [29] [Recommendation ITU-T G.7044/Y.1347](#): "Hitless adjustment of ODUflex (GFP)".
- [30] [Recommendation ITU-T G.698.4 \(05/2025\)](#): "Multichannel bi-directional DWDM applications with port agnostic single-channel optical interfaces".
- [31] [ETSI GS F5G 006](#): "Fifth Generation Fixed Network (F5G); End-to-End Management and Control; Release #1".
- [32] [IEEE 802.3df™-2024](#): "IEEE Standard for Ethernet Amendment 9: Media Access Control Parameters for 800 Gb/s and Physical Layers and Management Parameters for 400 Gb/s and 800 Gb/s Operation".
- [33] [Recommendation ITU-T G.9804.3](#): "50-Gigabit-capable passive optical networks (50G-PON): Physical media dependent (PMD) layer specification".
- [34] [Recommendation ITU-T G.987 series](#): "10-Gigabit-capable passive optical networks (XG-PON)".
- [35] [IETF RFC 8343](#): "A YANG Data Model for Interface Management".
- [36] [IETF RFC 8345](#): "A YANG Data Model for Network Topologies".
- [37] [IETF RFC 8639](#): "Subscription to YANG Notifications".
- [38] [IETF RFC 9232](#): "Network Telemetry Framework".

- [39] [ETSI ES 203 475](#): "Environmental Engineering (EE); Standardization terms and trends in energy efficiency".
- [40] [ETSI GS F5G 024 \(V1.1.1\)](#): "Fifth Generation Fixed Network (F5G); F5G Advanced Network Architecture; Release 3".
- [41] [ANSI/ISA-95.00.01-2025 \(IEC 62264-1\)](#): "Enterprise-Control System Integration - Part 1: Models And Terminology".
- [42] [ISO/SAE 21434:2021](#): "Road vehicles — Cybersecurity engineering," ISO/SAE, Geneva, Switzerland".
- [43] [IEC TS 62443-1-1:2009](#): "Industrial communication networks - Network and system security - Part 1-1: Terminology, concepts and models".
- [44] [Regulation \(EU\) 2016/679](#) of the European Parliament and of the Council of 27 April 2016 on the protection of natural persons with regard to the processing of personal data and on the free movement of such data, and repealing Directive 95/46/EC (General Data Protection Regulation), OJ L 119, pp. 1–88, May 4, 2016.
- [45] [ISO/IEC 18000-63 \(2021\)](#): "Information technology — Radio frequency identification for item management — Part 63: Parameters for air interface communications at 860 MHz to 960 MHz Type C".
- [46] [ETSI EN 302 208 \(V3.3.1\)](#): "Radio Frequency Identification Equipment operating in the band 865 MHz to 868 MHz with power levels up to 2 W and in the band 915 MHz to 921 MHz with power levels up to 4 W; Harmonised Standard for access to radio spectrum.
- [47] [IEC 61753-031-2 \(2014\)](#): "Fibre optic interconnecting devices and passive components - Performance standard - Part 031-2: Non-connectorized single-mode 1 × N and 2 × N non-wavelength-selective branching devices for Category C - Controlled environment".
- [48] [Recommendation ITU-T G.652 \(08/2024\)](#): "Characteristics of a single-mode optical fibre and cable".
- [49] [Recommendation ITU-T G.657 \(08/2024\)](#): "Characteristics of a bending-loss insensitive single-mode optical fibre and cable".
- [50] [Recommendation ITU-T G.697 \(11/2016\)](#): "Optical monitoring for dense wavelength division multiplexing systems".

2.2 Informative references

References are either specific (identified by date of publication and/or edition number or version number) or non-specific. For specific references, only the cited version applies. For non-specific references, the latest version of the referenced document (including any amendments) applies.

NOTE: While any hyperlinks included in this clause were valid at the time of publication, ETSI cannot guarantee their long-term validity.

The following referenced documents may be useful in implementing an ETSI deliverable or add to the reader's understanding, but are not required for conformance to the present document.

- [i.1] ETSI GR F5G 020 (V1.1.1): "Fifth Generation Fixed Network (F5G); F5G Advanced Use Cases; Release 3".
- [i.2] IETF RFC 3945: "Generalized Multi-Protocol Label Switching (GMPLS) Architecture".
- [i.3] IETF RFC 7138: "Traffic Engineering Extensions to OSPF for GMPLS Control of Evolving G.709 Optical Transport Networks".
- [i.4] IETF RFC 7139: "GMPLS Signalling Extensions for Control of Evolving G.709 Optical Transport Networks".
- [i.5] IETF RFC 9376: "Applicability of GMPLS for beyond 100 Gbit/s Optical Transport Network".

- [i.6] IETF draft-ietf-ccamp-otn-topo-yang: "A YANG Data Model for Optical Transport Network Topology".
- [i.7] IETF draft-ietf-ccamp-otn-tunnel-model: "OTN Tunnel YANG Model".
- [i.8] IETF draft-ietf-ccamp-otn-path-computation-yang: "A YANG Data Model for requesting Path Computation in an Optical Transport Network (OTN)".
- [i.9] IETF draft-ietf-ccamp-l1csm-yang: "A YANG Data Model for L1 Connectivity Service Model (L1CSM)".
- [i.10] IETF draft-ietf-ccamp-client-signal-yang: "A YANG Data Model for Transport Network Client Signals".
- [i.11] [Recommendation ITU-T G.9943 \(10/2025\)](#): "High speed fibre-based in-premises transceivers - network management".
- [i.12] [Recommendation ITU-T G.9949 \(10/2025\)](#): "Wireless local area network management control interface (WMCI) for in-premises network".
- [i.13] IEEE 802.11bn™: "IEEE Standard for Information Technology--Telecommunications and Information Exchange between Systems - Local and Metropolitan Area Networks--Specific Requirements - Part 11: Wireless LAN Medium Access Control (MAC) and Physical Layer (PHY) Specifications Amendment: Enhancements for Ultra High Reliability".
- [i.14] BBF TR-069: "CPE WAN Management Protocol (CWMP)".
- [i.15] BBF TR-369: "User Services Platform (USP)".
- [i.16] Recommendation ITU-T G.681: "Distributed fibre optic sensing system for terrestrial optical transmission system".
- [i.17] [Supplement 89 \(10/2025\)](#) to ITU-T G-series Recommendations: "Coordinated management of access and fibre in premises networks".
- [i.18] ETSI GS F5G 025: "Fifth Generation Fixed Network (F5G); F5G-A Architecture of computing collaboration in PON network".
- [i.19] IETF draft-ietf-ccamp-actn-optical-transport-mgmt: "Integrating YANG Configuration and Management into an Abstraction and Control of TE Networks (ACTN) System for Optical Networks".
- [i.20] BBF TR-383: "Common YANG Modules for Access Networks".
- [i.21] BBF TR-385: "ITU-T PON YANG Modules".
- [i.22] BBF WT-411i2: "Definition of interfaces between Cloud CO Functional Modules".
- [i.23] BBF WT-454i2: "YANG Modules for Network Map & Equipment Inventory".
- [i.24] ETSI GR F5G 021 (V1.1.1): "Fifth Generation Fixed Network (F5G); F5G Advanced Generation Definition".
- [i.25] IEEE 802.11ad™: "Telecommunications and Information Exchange between Systems Local and metropolitan area networks--Specific requirements-Part 11: Wireless LAN Medium Access Control (MAC) and Physical Layer (PHY) Specifications Amendment 3: Enhancements for Very High Throughput in the 60 GHz Band".
- [i.26] IEEE 802.11aj™: "Telecommunications and Information Exchange between Systems Local and metropolitan area networks--Specific requirements Part 11: Wireless LAN Medium Access Control (MAC) and Physical Layer (PHY) Specifications Amendment 3: Enhancements for Very High Throughput to Support Chinese Millimetre Wave Frequency Bands (60 GHz and 45 GHz)".

- [i.27] IEEE 802.11ay™: "Telecommunications and Information Exchange between Systems Local and Metropolitan Area Networks--Specific Requirements Part 11: Wireless LAN Medium Access Control (MAC) and Physical Layer (PHY) Specifications Amendment 2: Enhanced Throughput for Operation in License-exempt Bands above 45 GHz".
- [i.28] [Supplement 88 \(10/2025\)](#) to ITU-T G-series Recommendations: "Point to multipoint passive optical access system requirements and transmission technologies above 50 Gbit/s per wavelength".
- [i.29] IEEE 802.11bq™-2024: "IEEE Standard for Information Technology -- Telecommunications and Information Exchange between Systems - Local and Metropolitan Area Networks--Specific Requirements - Part 11: Wireless LAN Medium Access Control (MAC) and Physical Layer (PHY) Specifications Amendment: Enhancements for Integrated mmWave (IMMW) WLAN".
- [i.30] Object Management Group (OMG): "[OMG Data Distribution Service \(DDS\)](#)", Version 1.4, April 2014.
- [i.31] ETSI GS F5G 011 (V1.1.1): "Fifth Generation Fixed Network (F5G); Telemetry Framework and Requirements for Access Networks".
- [i.32] Recommendation ITU-T G.808.4: "Linear protection for fine grain Metro Transport Network (fgMTN) and fine grain Optical Transport Network (fgOTN)".
- [i.33] Recommendation ITU-T G.798: "Characteristics of optical transport network hierarchy equipment functional blocks".
- [i.34] Recommendation ITU-T G.8251: "The control of jitter and wander within the optical transport network (OTN)".
- [i.35] ETSI GR F5G 032 (V1.1.1): "Fifth Generation Fixed Network (F5G); F5G Advanced Use Cases; Release 4".
- [i.36] IETF draft-neumann-green-streaming-yang: "YANG Data Model for Energy Measurements in Streaming Devices".
- [i.37] IETF draft-stephan-green-ucs-and-reqs: "Requirements for Energy Efficiency Management".
- [i.38] IETF draft-cwbgp-green-common-energy-management: "A Common YANG Data Model for Energy Efficiency Network Management".
- [i.39] IETF RFC 9845: "Challenges and Opportunities in Management for Green Networking".
- [i.40] IETF RFC 8660: "Segment Routing with the MPLS Data Plane".
- [i.41] IETF RFC 8663: "MPLS Segment Routing over IP".
- [i.42] IETF RFC 9315: "Intent-Based Networking - Concepts and Definitions".
- [i.43] IETF RFC 8281: "Path Computation Element Communication Protocol (PCEP) Extensions for PCE-Initiated LSP Setup in a Stateful PCE Model".
- [i.44] OpenConfig-telemetry v0.5: "Data model which creates the configuration for the telemetry systems and functions on the device".
- [i.45] Recommendation ITU-T J.1318: "Requirements of E2E Network Platform for Cloud-based Object Wave Transmissions".
- [i.46] ETSI GR F5G 008: "Fifth Generation Fixed Network (F5G); F5G Use Cases Release #2".
- [i.47] Recommendation ITU-T Y.3187: "Architectural framework for machine learning function orchestrator in future networks including IMT-2020"3 Definition of terms, symbols and abbreviations".
- [i.48] ETSI GS F5G 023 (V1.1.1): "Fifth Generation Fixed Network (F5G); F5G Advanced Technology Requirements and Gap Analyses; Release 3".

- [i.49] ETSI GS F5G 016 (V1.1.1): "Fifth Generation Fixed Network (F5G); Data Models of Telemetry for Access Network".
- [i.50] [ITU-T G.Xfin-PHY](#): "High speed fibre-based in-premises transceivers - 10G Physical layer".
- [i.51] [ITU-T G.Xfin-DLL](#): "High speed fibre-based in-premises transceivers - 10G data link layer".
- [i.52] Recommendation ITU-T G.984.x: "Gigabit-capable Passive Optical Networks (G-PON)".
- [i.53] Recommendation ITU-T G.9807.x: "10-Gigabit-capable".
- [i.54] Recommendation ITU-T G.9805: "Coexistence of passive optical network systems".
- [i.55] Recommendation ITU-T G.9804.x: "Higher speed passive optical networks".
- [i.56] IETF RFC 6632: "An Overview of the IETF Network Management Standards".
- [i.57] IETF RFC 8641: "Subscription to YANG Notifications for Datastore Updates".
- [i.58] ETSI EN 303 645: "CYBER; Cyber Security for Consumer Internet of Things: Baseline Requirements".
- [i.59] EN 18031 series: "Common security requirements for radio equipment - Part 1: Internet connected radio equipment" (produced by CENELEC).
- [i.60] ISO/IEC 29167: "Information technology — Automatic identification and data capture techniques — Part 10: Crypto suite AES-128 security services for air interface communications".
- [i.61] [IEEE 802.1X™-2020](#): "IEEE Standard for Local and Metropolitan Area Networks--Port-Based Network Access Control".
- [i.62] [Recommendaiton ITU-T G.Sup89](#): "Coordinated management of access and fibre in premises networks".

3 Definition of terms, symbols and abbreviations

3.1 Terms

Void.

3.2 Symbols

Void.

3.3 Abbreviations

For the purposes of the present document, the following abbreviations apply:

ACTN	Abstraction and Control of Traffic Engineering Networks
AES	Advanced Encryption Standard
AFC	Automatic Fare Collection
AGGN	Aggregation Network
AI	Artificial Intelligence
AP	Access Point
API	Application Programming Interface
ASON	Automatically Switched Optical Network
BBF	BroadBand Forum
BE	Best Effort
BK	Background
BLF	Backscatter Link Frequency

BSS	Basic Service Set
BSSID	Basic Service Set ID
CBR	Constant Bit Rate
CCSA	China Communications Standards Association
CPE	Customer Premise Equipment
CPN	Customer Premise Network
CPU	Central Processing Unit
DAS	Distributed Acoustic Sensing
DBA	Dynamic Bandwidth Allocation
DC	Data Centre
DCI	Data Centre Interconnect
DCPS	Data-Centric Publish-Subscribe
DDS	Data Distribution Service
DFOS	Distributed Fibre Optic Sensing
DLL	Data Link Layer
DR	Disaster Recovery
DWDM	Dense Wavelength Division Multiplexing
E2E	End To End
EMF	Equipment Management Function
EML	Element Management Layer
E-ONU	Edge ONU

NOTE: Starting from Release 4, ETSI ISG F5G adopted the ITU-T SG15 Q3 term SFU.

FCAPS	Fault, Configuration, Accounting, Performance and Security
fgODU	fine grain Optical Data Unit
fgOTN	fine grain Optical Transport Network
FMCI	Fibre Management & Control Interface
FOADM	Fixed Optical Add/Drop Multiplexer
FTTR	Fibre to the Room
FTTx	Fibre To The (x = Room, Home, Machine, Office)
FWHM	Full Width Half Maximum
GE	Gigabit Ethernet
GIS	Geographic Information System
GMP	Generic Mapping Procedure
GMPLS	Generalized Multi-Protocol Label Switching
GPON	Gigabit Passive Optical Network
GPU	Graphics Processing Unit
HDMI	High-Definition Multimedia Interface
HVAC	Heating, Ventilation, and Air Conditioning
ID	Identification
IMMW	Integrate mmWave
IMP	Idle Mapping Procedure
IoT	Internet of Things
IP	Internet Protocol
IPTV	Internet Protocol Television
ISAC	Integrated Sensing and Communication
KQI	Key Quality Indicators
L2	Layer 2
LAN	Local Area Network
LR/ZR	Long Range / Data Rate optic series
M&C	Management and Control
MAC	Medium Access Control
MDR	Missed Detection Rate
MD-ROADM	Multi-Dimensional Reconfigurable Optical Add/Drop Multiplexer
ME	Management Entities
M-FTR	G.fin transceiver in the Main Fibre Unit
MFU	Main FTTR Unit
MGWS	Multiple Gigabit Wireless System
MIMO	Multiple Input Multiple Output
MMW	mmWave
MOS	Mean Opinion Score

MPEG	Moving Pictures Experts Group
MSOTN	Multi-Service OTN
MSTP	Multi-Service Transport Platform
NaaS	Network as a Service
NAS	Network Attached Storage
NE	Network Element
NPU	Network Processing Unit
NTP	Network Time Protocol
O&M	Operation and Maintenance
OADM	Optical Add/Drop Multiplexer
OAM	Operation Administration and Maintenance
ODN	Optical Distribution Network
ODU	Optical Data Unit
ODUK	Optical Data Unit k =0, 1, 2, 3, 4, flex
OFDM	Orthogonal Frequency Division Multiplexing
OIF	Optical Internetworking Forum
OLT	Optical Line Termination
OMCI	Optical Management and Control Interface
ONU	Optical Network Unit
ONU/AP	Optical Network Unit / Access Point
OPEX	Operational expense
OPGW	Optical Ground Wire
OS	Operating System
OSNR	Optical Signal to Noise Ratio
OSPF	Open Short Path First
OSU	Optical Service Unit
OSUFlex	Flexible Optical Service Unit
OTN	Optical Transport Network
OWT	Optical Wavelength Transport
OXC	Optical Cross Connect
P2MP	Point to MultiPoint
P2P	Peer-to-Peer
PCE	Path Computation Element
PCM	Pulse Code Modulation
PCS	Physical Coding Sublayer
PDH	Plesiochronous Digital Hierarchy
PHY	PHYSical (as in physical layer of a protocol)
PIS	Passenger Information System
PKT	Packet
PLOAM	Physical Layer Operation Administration and Maintenance
PMA	Physical Medium Attachment sublayer
PMD	Physical Medium Dependent sublayer
POL	Passive Optical LAN
PON	Passive Optical Network
P-ONU	Primary ONU

NOTE: Starting from Release 4, ETSI ISG F5G has adopted the ITU-T SG15 Q3 term MFU.

QAM	Quadrature Amplitude Modulation
QoD	Quality on Demand
QoE	Quality of Experience
QoS	Quality of Service
RaaS	Robotics as a Service
RF	Radio Frequency
ROADM	Reconfigurable Optical Add/Drop Multiplexer
ROS	Robotics Operating System
RTT	Round Trip Time
RUC	Requirement Use case
SA	Standards Association
SCADA	Supervisory Control and Data Acquisition
SDH	Synchronous Digital Hierarchy
SDN	Software Defined Networking

SDO	Standards Development Organisation
S-FTR	G.fin transceiver in an Sub Fibre Unit
SFU	Sub FTTR Unit
SG	Study Group
SINR	Signal to Interference and Noise Ratio
SLA	Service Level Agreement
SME	Small Medium Enterprise
SNMP	Simple Network Management Protocol
SNR	Signal to Noise Ratio
SOP	State Of Polarization
SR	Segment Routing
SR/DR	Short Range / Data Rate optic series
STA	Station
STM	Synchronous Transport Module
SU	Single User
TDM	Tine Division Multiplexing
TE	Traffic Engineering
TV	TeleVision
UC	Use Case
UHD	Ultra-High Definition
UHF	Ultra-High Frequency
UHV	Ultra-High Voltage
VBR	Variable Bit Rate
VC	Virtual Container
VI	Video
VO	Voice
VoIP	Voice over Internet Protocol
VR	Virtual Reality
WDM	Wavelength Division Multiplexing
WFA	Wi-Fi® Alliance
WLAN	Wireless Local Area Network
WMCI	WLAN Management & Control Interface
WP3	Working party 3 (ITU-T - Study Group 15)
WT	Working Text
XGS	10 G Symmetric
XGSPON	10 Gigabit Symmetric Passive Optical Network
YANG	Yet Another Next Generation data modelling language
ZSM	Zero-touch network and Service Management

4 F5G-A Technology requirements and landscape for Release 3 use cases

4.1 Overview

4.1.1 Introduction

This clause is reliant on the use cases as defined in ETSI GR F5G 020 [i.1] and specifies per use case the technology requirements, describes the gaps in technology to implement those use cases and the current available related standards.

NOTE: Some clauses define requirements, standards, and gaps for several similar use cases together.

The following use cases are included in the present document, refer to ETSI GR F5G 020 [i.1] for a detailed description of the use cases. In the following, only use case titles are given for reference:

- UC#1: Premium private line service automation: clause 4.2.
- UC#2: Stable & reliable Wi-Fi® connection over on-premises networking: clause 4.3.

- UC#3: Computing collaboration in PON network: clause 4.4.
- UC#4: Intelligent power grid: clause 4.5.
- UC#5: Railway perimeter inspection: clause 4.6.
- UC#6: Naked-eye 3D display: clause 4.7.
- UC#7: Unified access and on-premises network: clause 4.8.
- UC#8: OTN intelligent fault management: clause 4.9.
- UC#9: Evaluation and assurance of user service experience: clause 4.10.
- UC#10: Cloud Desktop: clause 4.11.
- UC#11: Dynamically digitalized ODN: clause 4.12.
- UC#12: F5G-A: On-premises Millimetre-Wave (mmWave) WLAN: clause 4.13.
- UC#13: Wavelength-shared WDM aggregation network (AGGN): clause 4.14.
- UC#14: Robotics as a Service: clause 4.15.
- UC#15: All-optical base for urban rail transit communication network: clause 4.16.
- UC#16: Optical Fibre Sensing for telecom operators: clause 4.17.
- UC#17: QoD App-Flow service provisioning: clause 4.18.

The clause 4 is similar to the release 3 description in ETSI GS F5G 023 [i.48], but the gaps are updated in case the gaps has already been solved in the meantime. In clause 5 below, the requirements and gap analyses for the release 4 use cases are described.

4.1.2 Document structure overview

The remainder of clause 4 covers the use cases release 3, itemized in clause 4.1.1. The structure of each use case is:

- Brief use case overview.
- Technology related to the use cases and associated requirements.
- Gaps in standards to meet the requirements.
- Current standards relevant to the use case.

The order of the use cases match that of those defined in ETSI GR F5G 020 [i.1] and the requirements are structured as [RUC#-xx] where UC# is the use case number defined in ETSI GR F5G 020 [i.1] and xx is the sequence number of the requirements. The Gaps have a similar structure [GapUC#-yy] and again UC# is the use case number defined in ETSI GR F5G 020 [i.1] and yy is the sequence number of the gaps. Ideally there should be a one to one correspondence between the requirements and the gaps, however it is possible that a given requirement may have multiple gaps and this will be accommodated in the present document. If the requirements are already satisfied by current standards then the gap is labelled 'None' to indicate there is no gap.

NOTE: There is an offset of one between the use case number and the clause number in the present document due to the inclusion of a clause on the present document overview in clause 4.1.

4.2 Premium private line service automation

4.2.1 Use Case Briefing

OTN / fine grain OTN (fgOTN) based premium private line services are widely used in many scenarios such as government institutions, financial organizations, medical organizations and large enterprises. In F5G-A, the automation capabilities of the premium private line services, such as CPE Plug-and-play, automatic service provisioning and SLA information visualization, need to be improved, to enable the evolution towards a higher-level autonomous optical network. See Use Case # 1 in ETSI GR F5G 020 [i.1] for more details.

4.2.2 Technology Requirements and Gap Analyses

4.2.2.1 General

Private line service automation capabilities are developed based on key features including of private line SLA evaluation before provisioning, E2E automatic configuration of both the customer's CPEs and the operator's OTN NEs for service provisioning, flexible bandwidth adjustment, and SLA information visualization.

4.2.2.2 Automatic evaluation of private line SLA before provisioning

The premium private line service provisioning system needs to be aware of the OTN resource information (including link bandwidth, latency and availability) in real-time, for both the electrical layer and the optical layer resources. Such information is the basic inputs for the service path computation and SLA evaluation.

[R1-1] The OTN electrical and optical layer resource information shall be reported to the premium private line service provisioning system in real-time.

The OTN control plane protocols, including the routing protocols, are defined by IETF. The new extensions to the OTN routing protocols supporting Recommendation ITU-T G.709/Y.1331 [1], including fgOTN, need to be supported in IETF.

[Gap1-1] Real-time resource discovery of fgOTN resources is currently not supported.

4.2.2.3 Agile service provisioning

The premium private line service provisioning system needs to automatically compute the service route, evaluate whether the calculated path can satisfy the SLA, and create the path for the service. If the OTN electrical layer has insufficient resources to support the service, it shall compute and create the new optical layer paths, to form the new electrical layer link resources for the requested service.

[R1-2] Computing and creating of both the OTN electrical and the optical layer paths shall be supported for private line service.

IETF develops the YANG data models for the electrical layer and the optical layer path computation and tunnel creation respectively. But currently there is no data model for computing and creating both the OTN electrical and optical layer paths for private line services.

YANG data models for fgOTN service provisioning have not been discussed yet.

[Gap1-2] Standardized YANG data models for computing and creating both the OTN electrical and optical layer paths for private line services are currently not supported.

4.2.2.4 CPE plug-and-play

The OTN CPEs are deployed on the customer's premises. In the scenario of automatic provisioning of premium private line services, once the CPE is connected to the operator's network through fibres, it should go online automatically, and the premium private line services are automatically configured on the CPE.

[R1-3] The network management and control system should support automatic discovery and automatic configuration of the OTN CPEs.

The CPE discovery and automatic configuration includes control channel creation, resource information discovery, service configuration, and alarm and performance management. Currently there is no related standard describing the procedure for how to discover and manage a CPE.

[Gap1-3] OTN CPE plug-and-play is currently not supported.

4.2.2.5 Bandwidth on Demand

The premium private line service customer may request a temporarily or permanent increase of the service bandwidth for a certain major event or higher bandwidth demand. In the temporary scenario once the event is over, the service bandwidth needs to revert to the original bandwidth. In the case of the permanent increase it will remain unless the customer requests it to revert.

[R1-4] The OTN shall support hitless bandwidth adjustment of an OTN connection.

[R1-5] The OTN shall support instant bandwidth adjustment of an OTN connection.

In the OTN Data Plane, OTN Recommendation ITU-T G.709/Y.1331 [1] supports an ODUflex container with a bandwidth of approximately $N \times 1,25$ Gbps. OTN also supports fgOTN with a bandwidth of approximately $N \times 10,4$ Mbps. Hitless bandwidth adjustment of both ODUflex and fgOTN is supported.

[Gap1-4] None.

In the OTN Control Plane, the YANG data models for the northbound interface of the Optical Transport Controller for fgOTN service modification have not been discussed yet.

[Gap1-5] Standardized YANG data models for bandwidth adjustment of an fgOTN connection is currently not supported.

4.2.2.6 Real-time visualization of private line SLAs

The network operators need to provide the private line network view and related open network APIs to the customers, so that the customers can monitor the private line SLAs (including, latency and availability) from their own perspectives.

The premium private line service provisioning system should support monitoring the SLA information of the private line service, and generating alarms when the SLA cannot be satisfied.

[R1-6] The premium private line service provisioning system shall support SLA information query and alarm report APIs.

Currently there are no standard APIs for the OTN management and control system to report the private line SLA information including service latency, traffic bandwidth, and availability to the customer. The alarm reporting for SLA degrade is also not supported.

[Gap1-6] Standardized APIs and YANG data models for SLA information query and alarm report are currently not supported.

4.2.3 Current related standard specifications

4.2.3.1 ITU-T

ITU-T SG15 Q11 has standardized the OTN series of Recommendations. Which includes:

- Recommendation ITU-T G.709/Y.1331 [1] defines the requirements for the OTN interface signals, including the OTN hierarchy, frame structures, bit rates and formats for mapping client signals.
- Recommendation ITU-T G.709.20 [2] provides an overview of functions provided by the fgOTN layer network.

ITU-T SG15 Q12 and Q14 are working together to define the management and control of the Optical Transport Network, including Automatically Switched Optical Networks (ASONs) and Software Defined Networking (SDN).

Q12 focuses on the Optical Transport Network architecture including the operational network aspects, while Q14 focuses on the management and control of the Optical Transport systems and equipment.

4.2.3.2 IETF

IETF has defined the GMPLS architecture for the control plane for different types of transport networks, and has added protocol extensions to support the control of the OTN:

- IETF RFC 3945 [i.2] which defines the architecture of the GMPLS.
- IETF RFC 7138 [i.3] which specifies the OSPF-TE routing protocol extensions to support GMPLS control of OTN specified in Recommendation ITU-T G.709/Y.1331 [1] as published in 2012.
- IETF RFC 7139 [i.4] which provide extensions to GMPLS signalling to control the full set of OTN features specified in Recommendation ITU-T G.709/Y.1331 [1] as published in 2012, including ODU0, ODU4, ODU2e, and ODUflex.
- IETF RFC 9376 [i.5] which examines the applicability of using existing GMPLS routing and signalling mechanisms to set up ODU connections over ODUCn links as defined in Recommendation ITU-T G.709/Y.1331 [1] published in 2020.

NOTE: The Recommendation ITU-T G.709/Y.1331 [1] published in 2012 and 2020 are older versions of Recommendation ITU-T G.709/Y.1331 [1].

IETF is now developing a set of YANG data models for the TE networks, and the augmentation of these YANG data models for OTN:

- IETF draft-ietf-ccamp-otn-topo-yang [i.6], which defines the YANG data model to describe the topologies of the OTN.
- IETF draft-ietf-ccamp-otn-tunnel-model [i.7], which defines the YANG data model for tunnels in OTN TE networks.
- IETF draft-ietf-ccamp-otn-path-computation-yang [i.8], which defines the YANG data model for requesting path computation in OTN.
- IETF draft-ietf-ccamp-l1csm-yang [i.9], which provides a YANG data model for Layer 1 Connectivity Service Model (L1CSM).
- IETF draft-ietf-ccamp-client-signal-yang [i.10], which provides a YANG data model for transport network client signals.

IETF has still not defined the control protocols and YANG models for the latest version of OTN (Recommendation ITU-T G.709/Y.1331 [1]), especially for the support of fgOTN.

4.3 Stable & reliable Wi-Fi® connection over on-premises networking

4.3.1 Use Case Briefing

The stability and reliability of the Wi-Fi® connection is essential for good end user QoE. Compared to the traditional multiple AP networking, which acts as independent cascaded backhaul links for the Wi-Fi® fronthaul link, a stable and reliable Wi-Fi® connection requires coordination between the different AP (including P-ONU and E-ONU) to avoid potential collisions. This requires dynamic coordination between the fibre link and the Wi-Fi® link for an FTTR on-premises network. A stable and reliable Wi-Fi® connection could provide benefits for the on-premises scenarios, including support for Gigabit/multi-Gigabit coverage, controlled latency boundary, seamless roaming, and stable IoT control. See Use Case # 2 in ETSI GR F5G 020 [i.1] for more details.

4.3.2 Technology Requirements and Gap Analyses

4.3.2.1 General

For the FTTR on-premises fibre network, a stable & reliable Wi-Fi® connection needs a centralized coordination architecture [3], facilitating a series of functions, including QoS identification, data collection, control messaging, module configuration. Based on the dynamic service requirements and Wi-Fi® channel sensing status, the centralized controller should make the correct decision and convey the control messages to each network devices for them to take timely actions.

Although the coordination architecture has been mentioned in different document from a number of SDOs, including ETSI ISG F5G and ITU-T SG15 Q3. There are still a number of gaps that need to be resolved before the practical implementation is achieved.

4.3.2.2 Service type identification and adaptation

The first step in deciding the allocation of network resources is to understand the QoS requirement by identifying the service type. In general, different network services can run in parallel within a single FTTR network. Mechanisms should be supported in the on-premises fibre network to differentiate the QoS flows in terms of network capability, including throughput, latency, packet loss rate, and packet jitter. The controller uses the QoS requirements to derive the dynamic scheduling for the dedicated packet flows under investigation (including the data buffer queue waiting time, the volume of data packets, and the Wi-Fi® air interface channel condition). The identification could be achieved by analysing the data flow behaviour, and recognizing the QoS indicators in the Ethernet frame or high-level protocols.

[R2-1] The fibre-based on-premises network shall support network application identification and the corresponding QoS mechanisms.

The fibre-based on-premises network needs an on-premises centralized controller dynamically supporting the data flow scheduling and configuration of each network device in the FTTR network.

[R2-2] The fibre-based on-premises network shall support an on-premises network centralized controller.

The current system uses Ethernet QoS identifiers to map the different QoS queues in the on-premises network system (such as Best Effort (BE), Background (BK), Video (VI), and Voice (VO) in Wi-Fi®). However, there may be several data stream from different service types using the same indicators. Improving the allocation of the network resources to the dedicated network services is required based on the identified QoS requirements. It is required that the system should identify the QoS requirements for each network service so that the scheduling procedure is specifically targeted to these network service data flows.

[Gap2-1] None.

[Gap2-2] None.

4.3.2.3 Wi-Fi® interference recognition and avoidance

Wi-Fi® interference exists when the neighbouring APs are working in overlapping channels. Especially for high-speed connection, spectrum limitation may lead to fewer number of channels with large bandwidth (160 MHz or 320 MHz). The detection of interference is necessary for the controller to understand the need for AP coordination in specific APs. This will require the controller to request and collect the interference information in real time from the peer APs or to allow the peer APs to regularly report such information.

Furthermore, in order to avoid interference, the Wi-Fi® transmission of each Wi-Fi® AP should be configured by the controller. Accordingly, interference mitigation can be achieved through the time-domain, the frequency-domain or the spatial domain. The fibre-based on-premises network shall support dynamically collecting Wi-Fi® channel information (including channel bandwidth and frequency, corresponding signal strength, channel duty cycle) so as to identify the neighbour's interference and the link quality of the end user device.

[R2-3] The fibre-based on-premises network shall support real time Wi-Fi® channel information collection.

[R2-4] The fibre-based on-premises network shall support continuous real time Wi-Fi® transmission behaviour configuration of each Wi-Fi® AP.

To achieve interference recognition the controller needs to understand the channel information in real time. On-time tuning requires fast decision making by the centralized controller, fast control message delivery and fast AP re-configuration. This process needs on-premises system level coordination from module to module of the network devices.

[Gap2-3] None

[Gap2-4] None

4.3.2.4 Provide latency sensitive transmission mechanism

Wi-Fi® transmission delay is in the range tens of microseconds to a few milliseconds. To support latency sensitive packets (including control messages or data packets) needs a dedicated controller messaging channel to transport the control information. This is the key to guaranteeing on time packet scheduling. In addition, an efficient control messaging procedure is necessary to reduce any redundancy during the control process.

The latency sensitive channel could further be utilized for low latency packet transmission, which is identified and recognized by the system.

[R2-5] The fibre-based on-premises network shall support a low latency control channel with a 64 μ s round trip time between the M-FTR and the S-FTR.

NOTE: The M-FTR is part of the P-ONU and the S-FTR is part of the E-ONU and are defined in Recommendation ITU-T G.9940 [7]. The M-FTR is the optical transceiver of the P-ONU while the S-FTR is the optical transceiver of E-ONU.

[R2-6] The fibre-based on-premises network shall support a control messaging procedure with bounded latency as required by the identified QoS.

G.fin is based on a P2MP infrastructure, in which the dynamic time allocation is applied for both downstream and upstream. To achieve low latency message transmission for the fibre and the wireless coordination, the on-premises fibre-based network should provide a protocol level mechanism to guarantee the transmission and reception of the messages. A dedicated message exchanging procedure needs to be defined over the latency sensitive channel for different technical features, including seamless handover.

[Gap2-5] None.

[Gap2-6] None.

4.3.2.5 Enable seamless connection switching

User mobility causes Wi-Fi® signal variation. To maintain a good quality connection within the fibre-based on-premises network, link selection between the end user device and dedicated AP is important. This requires link switching between network devices. In this case, seamless handover is essential. Completion of connection switching in handover can be achieved by traditional protocols, defined in IEEE 802.11k [4], IEEE 802.11v [5], IEEE 802.11r [6]. The protocol is based on L2+ transmission and is transparent to the fibre link and wireless link. The transmission of the handover packets is affected by scheduling of the fibre link and channel quality of the Wi-Fi® link. Any packet loss due to signal variation by user mobility or Wi-Fi® collision can result in switching delay or even failure.

A stable and reliable Wi-Fi® connection needs to provide a mechanism to achieve seamless switching for end user devices. The complex switching protocol may be simplified or discarded. Ideally, the handover process should be imperceptible to the end user device at the service level.

[R2-7] None.

To develop a full handover procedure, each step of the message transmission should be transmitted as high priority and no collision/retransmission should take place. A robust messaging channel and corresponding data model are forthcoming.

[Gap2-7] None.

4.3.3 Current related standard specifications

4.3.3.1 ITU-T

The majority of FTTR specification development has been focused on P2MP systems. The standardization is being developed in Recommendation ITU-T G.994x series [7] to [9] and [i.11]. Recommendation ITU-T G.9940 [7] specifies the system architecture and requirements. In particular, a centralized fibre and wireless coordination architecture has been defined, as shown in Figure 1. The MFU (same as P-ONU in ETSI ISG F5G) contains controller(s) that dynamically collect the network service QoS and characteristics (data buffer status, traffic priority, latency requirements, etc.), identify the network environment (such as channel status between the MFU and the SFU(s) (same as E-ONU in ETSI ISG F5G), interferences, etc.) and creates a strategy to coordinate the behaviour of the different networks connected to it. Based on the coordinator(s), fast network operation and control, including ordered medium access, global handover, real-time link visibility, etc. can be achieved. The interface between the controller/coordinator and Wi-Fi® APs is expected to be considered in the Wi-Fi® specification.

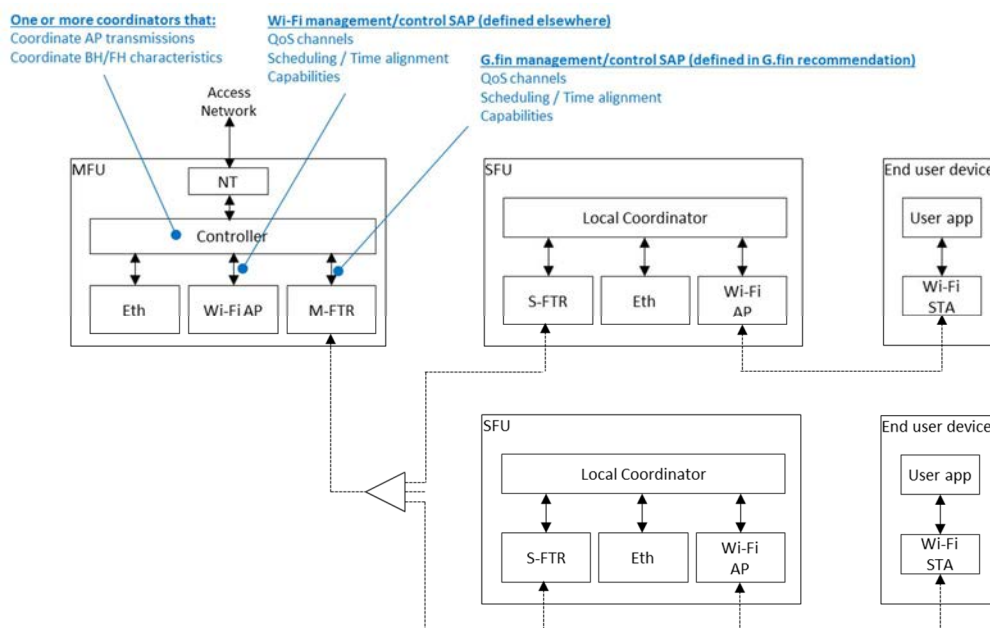

**Figure 1: Centralized fibre and wireless coordination architecture
(Source: Recommendation ITU-T G.9940 [7])**

Recommendation ITU-T G.9941 [8] specifies the Physical layer (PHY) for P2MP G.fin systems. There are two speeds of interest:

- 2,5 Gbps symmetrical (the near-term goal); and
- 10 Gbps symmetrical (the future goal).

In this context, the PHY includes the Physical Medium Dependent (PMD) sublayer, the Physical Medium Attachment (PMA) sublayer, and the Physical Coding Sublayer (PCS). In the PMD, the transmitted power, the receiver sensitivity and overload, the wavelengths of operation, and more are defined. The PMA includes the functions such as forward error correction, scrambling, and control of the physical layer upstream bursting. The PCS includes functions like the transmission frame assembly, bandwidth map creation, the PLOAM channel protocol, and the frame delineation.

Recommendation ITU-T G.9942 [9] specifies the Data Link Layer (DLL) for P2MP G.fin systems. The basic protocol stack of the DLL is shown in Figure 2. A dedicated L1/L2 control channel "WLAN Management & Control Interface" (WMCI [i.12]) is defined to convey the Wi-Fi® control messages.

Recommendation ITU-T G.9949 [i.12] specifies the protocol and corresponding data model, and also specifies low latency channels and seamless roaming exchange protocols.

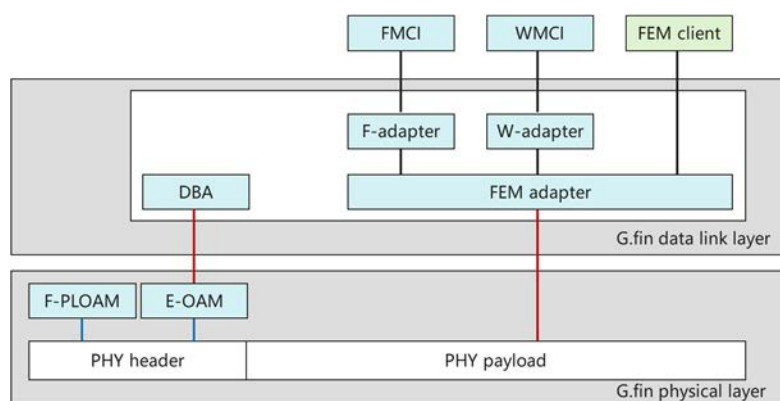

Figure 2: Protocol stack of G.fin DLL
(Source: Recommendation ITU-T G.9942 [9])

4.3.3.2 IEEE

IEEE 802.11bn [i.13] was started in 2023. This amendment of the IEEE 802.11 standard defines modifications to both the physical layer and medium access control layer that enhances the WLAN reliability:

- 1) Increase throughput, as measured at the MAC data service Access Point, at different Signal to Interference and Noise Ratio (SINR) levels (Rate-vs-Range), compared to extremely high throughput MAC/PHY operation.
- 2) Improve the tail of the latency distribution and packet jitter compared to extremely high throughput MAC/PHY operation, with mobility between BSSs.
- 3) Improve efficient use of the medium compared to extremely high throughput MAC/PHY operation.

IEEE 802.11bn [i.13] provides mechanisms for enhanced power savings for both the Access Point (AP) (including mobile AP) and the non-AP stations with improved Peer-to-Peer (P2P) operation compared to extremely high throughput MAC/PHY operation.

IEEE 802.11bn [i.13] applies to carrier frequencies operation between 1 GHz and 7,250 GHz. This amendment shall ensure backward compatibility and coexistence with legacy IEEE 802.11 devices in the 2,4 GHz, 5 GHz and 6 GHz unlicensed bands.

One of the core features under development in IEEE 802.11bn [i.13] is multi-AP coordination, in which a coordination scheme is deployed in the air interface to share the commonly used transmission opportunities. This helps to avoid collision through coordination.

4.4 Computing collaboration in PON network

4.4.1 Use Case Briefing

The computing collaboration of various network element in the E2E Optical access Network (PON) will make better use of the heterogeneous capabilities of dedicated devices to enable improved quality and higher efficiency for delivering network services. For example, to improve the QoE for communication, the network needs to identify the service type, the related QoS requirement, assign network scheduling to the dedicated network element, and coordinate with each by exchanging network status information. For the computing services, the image storage takes place in a Network Attached Storage (NAS) device, image editing takes place in the mobile device and image rendering takes place in the P-ONU. The collaboration procedure may be very diverse, depending on the service demand. Therefore, computing collaboration is necessary to be adapted for the different applications, dynamically organizing the necessary resources. See Use Case # 3 in ETSI GR F5G 020 [i.1] for more details.

4.4.2 Technology Requirements and Gap Analyses

4.4.2.1 General

For computing collaboration in the PON network, there are multiple network elements involved, including a cloud platform (traditionally providing management functions, big data analysis could also be enable there), an OLT (close to the end user and could have large computing resources for edge computing), a P-ONU (the network terminal, to schedule the network resources and take part in distributed computing using spare CPU/GPU capability), and an E-ONU (the access point to control the quality for the last-meter connection and sensing the behaviour of the end user). These network elements will require dedicated computing functionality in the different devices, and efficient communication and coordination between the devices.

4.4.2.2 Heterogeneous computing capability

To facilitate the computing function in the network elements for diverse service and dynamic computing, additional computing capability is needed. Dedicated computing hardware including CPU/GPU/NPU should be integrated at the system level, such as the OLT or the P-ONU. Therefore, independent computing-oriented software or applications can be run without affecting the normal data transmission. Additional computing-oriented hardware or modules need to be supported in the PON network elements (including the OLT, the P-ONU and the E-ONU) to support computing functions and collaboration.

[R3-1] The PON network elements shall support additional computing-oriented hardware or modules.

The traditional optical access network is designed mainly for data transmission. The typical computing module in the PON network is DBA, which calculates the data transmission requirements and grant transmission opportunities in the time domain to schedule upstream transmission for the connected ONUs. It is also similar for the P-ONU in the FTTR network.

[Gap3-1] Additional computing-oriented hardware or modules in the current PON network elements, including the OLT, the P-ONU and the E-ONU are currently not available.

4.4.2.3 Identification of service flow & corresponding demand

The goal for computing collaboration is to satisfy the service flow SLA requirements. This is similar to the requirements in Use Case # 2 clause 5.2 of ETSI GR F5G 020 [i.1]. The PON network shall be capable of identifying the service flows and understand the corresponding requirements. This can be done by the PON network itself or managed by an external entitle such as the cloud platform. The PON shall also identify the corresponding QoS requirements, including throughput, latency, and packet jitter.

[R3-2] The PON network shall support service flow identification and identification of the corresponding QoS requirements.

Traditionally, the data priority is identified by the Ethernet QoS indicators, which do not provide quantitative requirements to inform the network how to achieve dynamic scheduling or collaboration.

[Gap3-2] A dynamic and quantitative QoS indication scheme for practical data flows for the PON network are currently not available.

4.4.2.4 Dynamic collaboration between the PON network elements and the computing elements

Dynamic collaboration takes place between multiple network elements, including the cloud platform, the OLT, the P-ONU and the E-ONU. The interfaces between the different network elements are the key to collecting collaboration data and forwarding the configuration. The algorithm for computing collaboration is based on the status of the collection and sensing.

[R3-3] The cloud platform shall support the enabling or disabling computing collaboration of the OLT, the P-ONU or the E-ONU.

[R3-4] The cloud platform shall be capable of collecting the computing capability information and utilization of the OLT, the P-ONU or the E-ONU computing resources.

[R3-5] The OLT shall support a computing collaboration information and configuration exchange interface with the P-ONU and the E-ONU.

NOTE 1: This interface is protected by a secure mechanism.

[R3-6] The on-premises network P-ONU shall support a computing information and configuration exchange interface with the E-ONU.

NOTE 2: This interface is protected by a secure mechanism.

Information and configuration exchanges are at the core for the coordination between multiple network elements. Protocol design and a data model to support this collaboration is necessary. Extensions to the current protocols or new protocols are needed to be considered according to the computing collaboration requirements.

[Gap3-3] A Collaboration function is not defined in the current E2E system.

[Gap3-4] A Data model for computing collaboration is currently not available in BBF TR-069 [i.14] and BBFTR-369 [i.15].

[Gap3-5] A Data model for computing collaboration is currently not available in OMCI [10].

[Gap3-6] A Data model for computing collaboration is currently not available in FMCI [i.11] or WMCI [i.12] for the on-premises network.

4.4.3 Current related standard specifications

4.4.3.1 ITU-T

ITU-T SG15 defines interfaces for PON and FTTR networks:

- 1) Between the OLT and the P-ONU based on OMCI [10].
- 2) Between the P-ONU and the E-ONU based on FMCI [i.11].

ITU-T SG15 Q2 defined the Optical Management & Control Interface (OMCI) [10] for P-ONU management by the OLT, shown as the I2 interface in Figure 3. This interface is a layer 2 management interface, having higher transmission priority in an independent logic channel.

ITU-T SG15 Q3 defined the Fibre Management & Control Interface (FMCI [i.11]) and WLAN Management & Control Interface (WMCI [i.12]) to exchange management or control information for the fibre link and the Wi-Fi® link.

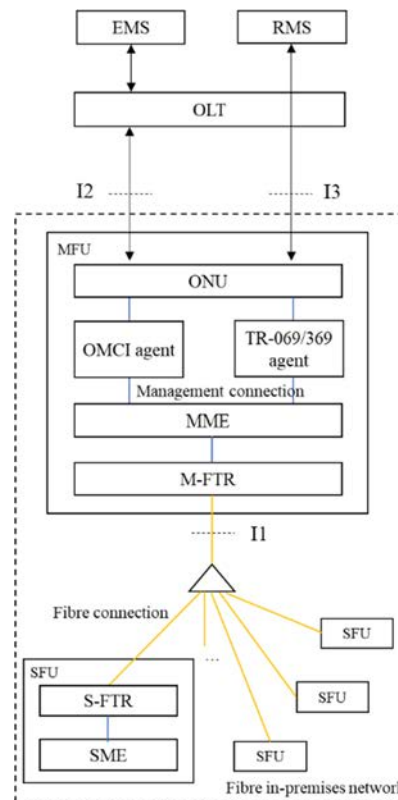

**Figure 3: An example of management scheme of FTTR
(Source: Recommendation ITU-T G.9940 [7])**

Computing collaboration information may be defined based on the current protocol stack. In this case, an additional data model should be considered.

4.4.3.2 BBF

BBF TR-069 [i.14] defined for P-ONU management by a cloud platform. An evolution of BBF TR-069 [i.14] was developed to enable information exchanged between any network element in the form of "controller" and "agent" For details, refer to clause 4.5.3.3 of ETSI GS F5G 013 [11].

4.5 Intelligent power grid

4.5.1 Use Case Briefing

The current power grid communication network uses multiple transmission technologies such as OTN, SDH, PDH and PON to provide a secure and reliable communication infrastructure for the power grid relay protection system, security stability system, and power grid automation system, including dispatching automation, transmission and transformation automation, and distribution automation. It also provides information services for power grid headquarters, the branches and the operation centres. The transition from the current power grid communication network to an intelligent power grid communication network is driven by the need for intensive substations, unmanned substations, distributed new energy grid connectivity, and Ultra High Voltage (UHV) grid deployment. See Use Case # 4 in ETSI GR F5G 020 [11] for more details.

4.5.2 Technology Requirements and Gap Analyses

4.5.2.1 General

The current power communications network needs to be upgraded to the new intelligent power grid communication network so that it can provide an end-to-end high-quality connectivity infrastructure to meet the needs of the intelligent and cloud-based power grid.

For the data centre communication network of the intelligent power grid, an optical transport network with higher capacity up to 800 G is needed for intra-city Data Centre Interconnect (DCI).

For the backbone communication network of the intelligent power grid, needs to support ultra-large State Of Polarization (SOP) and an ultra-long single-span transmission network, 10 Gbps and 100 Gbps or beyond coexisting transmission network, which meets the power grid requirements, including Optical Ground Wire (OPGW) cables, long distance between sites, and smooth flexible bandwidth updatability.

For the substation communication network of the intelligent power grid, requires a new fine grain Time-Division Multiplexing (TDM) technology to replace the legacy and end of life SDH/PDH technology. The fine grain TDM technology can be used in the power distribution access network and the substation campus access network, to provide the multiple services transport capabilities as well as providing the end-to-end high-quality connections across the power grid communication network.

4.5.2.2 High capacity optical transport network

For the data centre communication network of the intelligent power grid, the interconnection bandwidth between Data Centres (DCs) and Disaster Recovery (DR) centres, the interconnection bandwidth between the DC and the headquarters, and the access bandwidth between the DC and the branches are increasing rapidly. A higher capacity optical transport network is needed to provide higher bandwidth and more connections.

[R4-1] The DCI network of the intelligent power grid shall support up to 800 Gbps per wavelength up to 80 km.

In the backbone transport network, there is a need for ultra-large State Of Polarization (SOP) for Optical Ground Wire (OPGW) cables and ultra-long single-span for 500 km long distances between sites. At the same time, the backbone transport network is being updated from 10 Gbps to 100 Gbps or beyond per wavelength, so 10 Gbps and 100 Gbps or beyond coexisting is required in the same fibre.

[R4-2] The backbone transport network of the intelligent power grid shall support ultra-large State Of Polarization (SOP) with at least 8 M rad/s.

[R4-3] The backbone transport network of the intelligent power grid shall support ultra-long single-span of at least 500 km.

[R4-4] The backbone transport network of the intelligent power grid shall support 10 G and 100 G coexisting on the same fibre.

However, for the DCI network of the current power grid, the interconnection bandwidth between data centres is mainly 100 Gbps or 200 Gbps per wavelength, there are a number of 400 Gbps wavelengths. The 800 Gbps interface for DCI/Metro applications is specified in other SDOs, such as ITU-T SG15 and OIF. It can meet the demands of the intelligent power grid communication network.

[Gap4-1] None.

SOP with at least 8 M rad/s and 10 Gbps and 100 Gbps or beyond coexisting on the same fibre technology is currently available. But ultra-long single-span with at least 500 km technology is not mature.

[Gap4-2] None.

[Gap4-3] Ultra-long single-span with at least 500 km technology is currently unavailable.

[Gap4-4] None.

4.5.2.3 Fine grain optical transport network

In the current substation communication network, legacy and end of life SDH as a TDM technology, is still used to carry power grid production services, including relay protection services, security stability services and dispatching automation services, which require hard isolation, deterministic low latency, high reliability, and high security.

As the power grid is evolving to an intelligent power grid, the intensive substations and unmanned substations are driving the bandwidth increase from 2 Mbps to 20 Mbps or even 50 Mbps. The number of connections to the primary substations is increasing from hundreds to thousands for dispatching automation and the new services such as video services and IoT services. The current substation transport network cannot meet the growing demand for the increased bandwidth and larger number of connections. A new fine grain TDM technology is required as an alternative to SDH technology once SDH equipment is obsoleted. This new technology needs to support equivalent properties as SDH including hard isolation, low latency, low latency variation and efficiently support carrying a large number of sub 1 G services. N by 10 Mbps tributary slots for $N \leq 119$ will allow for substations bandwidth growth.

- [R4-5] The substation transport network of the intelligent power grid shall support fine granularity with 10 Mbps tributary slots.
- [R4-6] The substation transport network of the intelligent power grid shall support hard isolation, low latency, low latency variation, Operation, Administration and Maintenance (OAM).
- [R4-7] F5G Advanced network of the intelligent power grid should support migration of legacy SDH networks.

Timing transparency is essential for this new fine grain technology in order to replace the SDH synchronous network in particular for Constant Bit Rate (CBR) services such as E1 and STM-n.

- [R4-8] The substation transport network of the intelligent power grid shall support timing transparent transmission for CBR services.

In addition to CBR traffic, this new fine grain technology needs to be flexible and support hitless bandwidth adjustment capabilities for Variable Bit Rate (VBR) packet services such as IP/Ethernet services.

- [R4-9] The substation transport network of the intelligent power grid shall support agile and hitless bandwidth adjustment capabilities.

OTN is a TDM technology that provides guaranteed bandwidth and latency performance. However, the minimum rate of the current ODUk connection is ODU0 with approximate 1,25 Gbps bitrate, and the minimum granularity of the current ODUk connection is 1,25 Gbps, which cannot efficiently map sub 1 G services or support a large number of fine granularity sub 1 G services. The fine grain OTN technology is specified in ITU-T SG15 WP3. Flexible optical service unit (OSUFlex) of the Optical Transport Network (OTN) in power systems was specified in IEEE P2893 [17] in parallel. With the standardization of fgOTN and OSU, these new technologies can well serve the demands of the intelligent power grid once SDH is obsoleted, and provide fine granularity, low latency, low latency variation, efficiently carrying a large number of sub 1 G services.

- [Gap4-5] None.
- [Gap4-6] None.
- [Gap4-7] None.
- [Gap4-8] None.
- [Gap4-9] None.

4.5.2.4 End-to-end high-quality connection

The access network for the power distribution and the substation campus needs to differentiate service types and provide different QoS, including real-time and non-real-time production control services for dispatching automation, distribution automation, video surveillance services, IoT terminal connection services, and power consumption data services. All the services in different security zones are transmitted on the same physical network. Hard isolation and multi-service transport capabilities are needed. In particular, for the key priority services, the end-to-end high-quality hard isolation connections across the distribution access network and substation transport network should provide guaranteed bandwidth and latency performance.

- [R4-10] The communication network of the intelligent power grid shall support an end-to-end high quality hard isolated connections.

In addition, optical transport network services are the foundation of the emerging intelligent power grid. For the flexible scheduling requirements of the intelligent network, a multi-level flexible scheduling mechanism based on Optical Cross-Connect (OXC), Optical Data Unit (ODU), and fgOTN needs to be constructed to implement intelligent coordinated scheduling at the wavelength, channel, and service levels, and meet the high-quality connections.

[R4-11] The communication network of the intelligent power grid shall support a multi-level flexible scheduling mechanism at the wavelength, ODU as channel, and fgOTN as service levels.

However, in the current power grid communication network, the services need to be demapped from one connection in the power distribution access network or the substation campus access network, and then mapped to another connection in the substation transport network and the backbone transport network. An end-to-end high quality hard isolated connection across the power grid communication network is currently unavailable.

[Gap4-12] None.

[Gap4-13] None.

4.5.3 Current related standard specifications

4.5.3.1 ITU-T

Over the past 30 years, ITU-T has driven the standardization of OTN, with the line rate of OTN increasing from 1,25 Gbps to 400 Gbps and beyond. Currently, OTN technology is evolving to the next generation in two directions. The first direction is beyond 400 G OTN technology, which is standardized by ITU-T [1], [12], [13], [14], and [15] in order to support 800 GE clients mapping and up to 800 Gbps flexible OTN interface. The second direction is fine-grain OTN with 10 Mbps bandwidth granularity, which is standardized by Recommendation ITU-T G.709.20 [2], Recommendation ITU-T G.709/Y.1331 [1] annexes M and O, and Recommendation ITU-T G.872 [16] in order to efficiently support a large number of high-quality sub 1 G services and the migration of legacy SDH networks, increasing the value of OTN to meet the future communication demands. Figure 4 illustrates the overview of the OTN structure from Recommendation ITU-T G.872 [16].

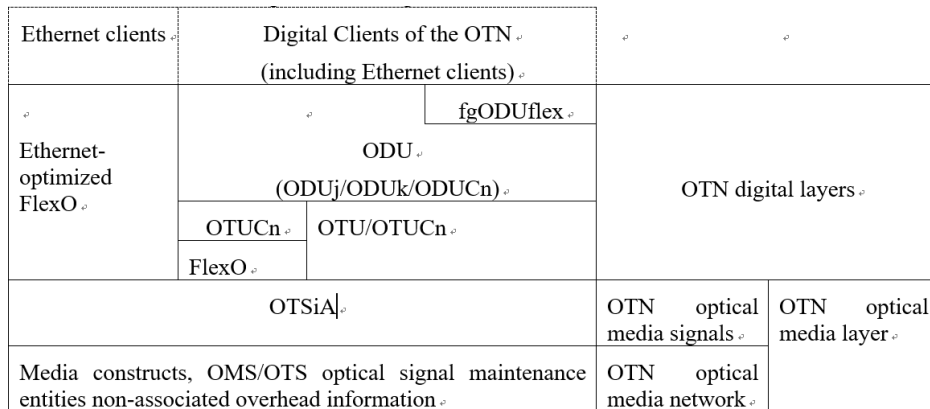

Figure 4: Overview of the OTN structure

SDH and OTN are Time-Division Multiplexing (TDM) technologies that provide guaranteed bandwidth and latency performances. As the next generation TDM technology after SDH, fgOTN is expected to provide fine granularity, high-quality TDM connections for Constant Bite Rate (CBR) services once SDH networks are obsoleted from the transport network, where the multi-layer network structure of OTN+SDH will be simplified to a unified OTN network including fgOTN. In addition, the fgOTN connections need to support Variable Bit Rate (VBR) services such as Ethernet Packet (PKT) services with agile and hitless bandwidth adjustment capabilities. Figure 5 shows the overview of the fgOTN layer network inside OTN. The fgOTN complements the existing OTN with an additional fgOTN layer network that efficiently and reliably carries the sub 1 G services as an optimal alternative to the SDH technology.

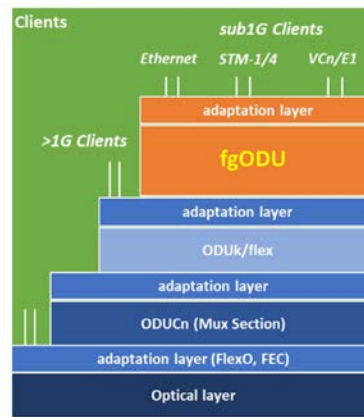

Figure 5: Overview of the fgOTN layer network inside OTN

Figure 6 shows the information structure for fgOTN layer network with the key functions and capabilities as follows:

- The fgOTN supports mapping the client service into fgODU path layer, including Ethernet services ($p \times 10$ M, $p = 1$ to 119) via IMP, CBR services (STM-1, STM-4, VC-n, E1) via GMP.
- The fgOTN supports multiplexing multiple fgODU paths into ODU0/1/2/flex. The bandwidth granularity is 10 Mbps.
- The fgOTN supports fgODU 1+1 protection.
- The fgOTN supports timing transparent transport for CBR services, meeting the jitter and wander requirements defined in Recommendations ITU-T G.823 [18] and G.825 [19].
- The fgOTN supports fgODU hitless bandwidth adjustment function for packet services.

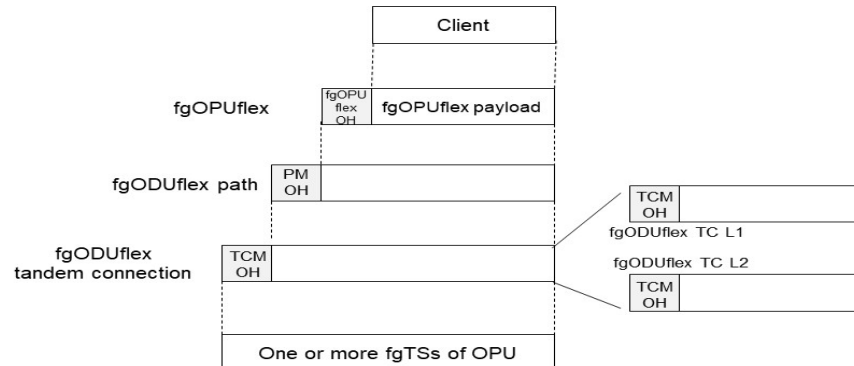

Figure 6: The information structure of the fgOTN layer network

The first set of four core fgOTN recommendations have been consented, including Recommendation ITU-T G.709.20 [2] on fgOTN overview, Recommendation ITU-T G.709/Y.1331 [1], Annex M on fgOTN interface, Annex O on fgOTN hitless bandwidth adjustment, and Recommendation ITU-T G.872 [16], Annex A on fgOTN path layer network architecture, in the ITU-T SG15 Plenary Meeting held during November 20th to December 1st, 2023 in Geneva. The remaining fgOTN recommendations were consented in ITU-T SG15 Plenary Meeting held during July 1st to 12th 2024 in Montreal, including Recommendation ITU-T G.808.4 [i.32] on fgOTN protection, Recommendation ITU-T G.798 [i.33] amendment 1 on fgOTN equipment and Recommendation ITU-T G.8251 [i.34] amendment 1 on fgOTN synchronization.

With the full TDM characteristics, fgOTN is an ideal TDM technology to serve as the next-generation TDM technology replacing SDH, and provide fine granularity, hard isolation, low latency, and low latency variation. The fgOTN technology efficiently carrying a large number of sub 1 G services, supports synchronized connections for CBR services, as well as agile and hitless bandwidth adjustment capabilities for VBR services.

4.5.3.2 IEEE

IEEE P2893 [17] has been approved in 2023. This standard specifies a communication layer, Flexible Optical Service Unit (OSUflex) to provide small service channels in optical transport networks. The main features of the OSUflex communication layer provide a large number of OSUflex connections to directly carry power services into an optical transport network, enabling the flexible bandwidth and hitless bandwidth adjustment for each OSUflex connection, direct mapping of services into OSUflex with the capabilities of high-bandwidth efficiency, low latency, low latency jitter and high-precision clock synchronization for power system applications.

4.6 Railway perimeter inspection

4.6.1 Use Case Briefing

As the main means of transportation and an important infrastructure, the railway system plays an important role in the economic and social development. For railway transportation, safety is the highest priority, but factors including illegal intrusion onto the railway tracks, illegal destruction or crossing the railway fence, rock fall, landslide, and other factors threaten the train's safety. With the growth and expanse of the railway system, continuing to rely upon personnel patrolling the railway perimeter is becoming less efficient and time consuming. New technologies need to be explored to further strengthen the perimeter inspection capability along the railway track.

Vegetation, animals, pedestrians, vehicles, wind, rain, snow, fog and other complex weather and environment conditions pose serious challenges to the reliability, adaptability and stability of the perimeter inspection system. With the rapid development of sensing technologies, the optical fibre sensing technology provides full coverage, all-weather, and all-intelligence technology for the railway perimeter inspection. Vibrating optical fibre is easy to deploy and is cost-effective. The optical fibre sensing technology is suitable for detecting human intrusion along irregular and sheltered long-fence distances. The optical fibre sensing technology is an important technical protection measure for railway perimeters inspection. See Use Case # 5 in ETSI GR F5G 020 [i.1] for more details.

4.6.2 Technology Requirements and Gap Analyses

4.6.2.1 General

The technical capability of the perimeter inspection system along the railway track needs to be an efficient mechanism to prevent human intrusion and physical damage. Up to now, the security of important facilities along the railway tracks, such as communication stations, substations and other facilities mainly relies on manual patrols by railway protection personnel on sites or remote patrols via the existing video surveillance system. Due to the lack of technical prevention mechanisms, capabilities, and the limitation of the perimeter patrol in terms of patrol range, none real-time, and efficiency, human intrusions and foreign object intrusions occur frequently on the perimeter of the railway tracks. This results in a large amount of property loss or damage, especially on the high-speed railway line. High-speed trains need a longer braking distance to respond to an emergency situation. The safety of the high-speed railway line operating environment has been the main challenge of the railway safety operation. The occurrence of the railway perimeter security risk is sudden, hidden and complex. These malicious acts or potential dangers are a serious safety risk to railway transportation. These shortcomings are overcome by deploying an optical fibre sensing railway perimeter inspection system.

4.6.2.2 Fibre sensing performance

Railway perimeter inspection fibre sensing technology needs to support the following functions and capabilities:

The maximum distance between the communication stations is up to 100 km, so the unidirectional coverage range shall be at least 50 km to cover the full range.

[R5-1] Unidirectional coverage range shall be greater than 50 km.

[Gap5-1] Standards which support unidirectional coverage range greater than 50 km are currently unavailable.

The perimeter intrusion event detection system needs to improve the detection rate of the true intrusion events and reduce the number of missed intrusion events as much as possible. The detection rate needs to be greater than 99,9 %.

The detection rate is the detected number of true intrusion events divided by the actual number of true intrusion events:

$$\text{Detection rate} = \frac{\text{Detected number of true intrusion events}}{\text{Actual number of true intrusion events}}$$

[R5-2] The detection rate of true intrusion events shall be greater than 99,9 %.

[Gap5-2] Standards which support the detection rate greater than 99,9 % are currently unavailable.

The perimeter intrusion event system needs to reduce the false intrusion event detection as much as possible, the frequency of such false intrusion events per month period needs to be less than 0,002 events/km/hour on average.

[R5-3] The frequency of false intrusion events shall be less than 0,002 events/km/hour on average.

[Gap5-3] Standards which support the frequency of false intrusion events less than 0,002 events/km/hour on average are currently unavailable.

The position accuracy of the perimeter intrusion event detection system needs to be less than 10 m.

[R5-4] The position accuracy of the true intrusion event detection shall be less than 10 m.

[Gap5-4] Standards which support the position accuracy less than 10 m are currently unavailable.

The perimeter intrusion event detection system needs to support real-time response. Within the monitoring range of the detection sensor, the response time from the start of an intrusion event to the time reported by the monitoring centre needs to be less than 5 s.

[R5-5] Intrusion event identification time shall be less than 5 s.

[Gap5-5] Standards which support intrusion event identification time less than 5 s are currently unavailable.

4.6.3 Current related standard specifications

4.6.3.1 ITU-T

ITU-T SG15 Q6 is defining a standard in Recommendation ITU-T G.681 [i.16] (distributed fibre optic sensing) to specify the fibre sensing system for monitoring fibre cable.

4.7 Naked-eye 3D display

4.7.1 Use Case Briefing

Naked-eye 3D display provides 3D visual sensing from the human eye to the brain without the need for external objects on the human body, such as 3D glasses, helmet, etc. It can be applied in a wide range of application, for sport broadcasting, variety show, live news, education & training, gaming, etc. A high end naked-eye 3D display provides high resolution video streaming and multiple viewpoints with sensing functionality for eyeball tracking, voice interaction or gesture recognition. See Use Case # 6 in ETSI GR F5G 020 [i.1] for more details.

4.7.2 Technology Requirements and Gap Analyses

4.7.2.1 General

Due to the high-resolution video streaming in 3D and the multiple viewpoints to support visual imaging for multiple customers simultaneously, the high end naked-eye 3D display requiring extremely high throughput [i.1]. For example, a typical 4K display over H.265 compression with 36 viewpoints requires 1,14 Gbps while an 8K display over H.265 compression with 84 viewpoints requires 10,68 Gbps (see Table 2 of ETSI GR F5G 020 [i.1]). Moreover, the imaging content should adapt to the human's position or commands for interaction activities (like gaming). This requires latency restrictive transmission for small control or information feedback package.

4.7.2.2 Extremely high throughput

The naked-eye 3D display is initially deployed for business application for advertisement. This requiring high throughput in the downstream direction. On another hand, for live applications, the uplink collection of 3D data is necessary while the content is processed remotely in the cloud and then sent for display as downlink. Therefore, bilateral high throughput is needed. In the future, it will evolve to residential applications over mobile phone, laptop, tablets or TV. The F5G-A E2E network shall support 10 Gbps for the end user. In particular, the optical access network and the on-premises network shall enable 10 Gbps throughput.

[R6-1] The F5G-A access network shall provide symmetric 10 Gbps data rate for each subscriber.

[R6-2] The FTTR on-premises network shall provide symmetric 10 Gbps data rate.

It is necessary to evolve the traditional F5G-A network to have support for naked-eye 3D display for excellent user experience. XGSPON and 2,5 G FTTR may not be sufficient in this case. ITU-T SG15 Q2 has completed the 50 GPON standardization while 10 G FTTR is still in its infancy.

[Gap6-1] None.

[Gap6-2] None.

4.7.2.3 Latency restricted transmission

The latency requirements come from the interaction activities from dedicated use case, like gaming, 2D to 3D switching. Since the processing is located in the cloud and the naked-eye 3D display is exposing the content to the user, which is very similar to the Cloud VR use case (in which Cloud VR phase 3 and phase 4 requirements in Table 1 of ETSI GS F5G 013 [11], requires 8 ms to 10 ms E2E RTT), for this real-time interactive application.

[R6-3] The E2E F5G-A network shall support < 10 ms RTT.

To have an aggregated RTT through the E2E F5G-A network, the different network segments shall coordinate with each other to satisfy the quality demand of latency.

[Gap6-3] The unified E2E latency control is not specified yet. E2E coordination mechanism is still currently not available.

4.7.3 Current related standard specifications

4.7.3.1 ITU-T SG15

The G.Xfin specification are currently under development in the ITU-T Work Items [G.Xfin-PHY](#) [i.50] and [G.Xfin-DLL](#) [i.51].

4.8 Unified access and on-premises network

4.8.1 Use Case Briefing

A cooperative DBA mechanism in data transmission between the F5G-A access network and the on-premises network achieves control of network QoS. Through a wider view of the service type, the buffering status, the network resource, etc., dynamic optimization can be achieved in terms of different network performance demands (i.e. throughput, latency, and packet jitter). Additionally, a coordinated management scheme provides accurate diagnostic of network issues, fast service provisioning, optimization of the network configuration, asset monitoring, etc. In the F5G-A access networks, it is important to provide optimized resources allocation, asset monitoring, energy saving, etc. See Use Case # 7 in ETSI GR F5G 020 [i.1] for more details.

4.8.2 Technology Requirements and Gap Analyses

4.8.2.1 General

A unified F5G-A access network and on-premises network enhances the network performance and reduces the network management complexity of the control and management plane, respectively (OMCI between OLT and P-ONU, WMCI [i.12]/FMCI [i.11] between P-ONU and E-ONU). There is no requirement to change the physical topology, instead make a logical cooperation of the packet scheduling and management methodologies. A wider packet scheduling view can reduce the E2E transmission latency & packet jitter, optimize the data buffer, and enable network slicing. This is beneficial for the QoE of the end users. Utilizing the computing power of the device in central office (OLT) to provide a more accurate data transmission strategy. A coordinated management provides a global map of the device status enabling improved utilization of the network resources (time/spatial/spectrum) as well as perform asset monitoring.

4.8.2.2 Provide unified control of data transmission

Global control by the OLT to coordinate the F5G-A access network segment and the on-premises network segment will enable unified control. This requires an accurate and timely control signalling and deterministic scheduling. A protocol with a bounded latency is a necessity for message exchange. A L1 or L2 lower layer protocol like OMCI [10] or enhanced OMCI might be necessary. Control device (OLT, P-ONU, and E-ONU) data models should be defined.

- [R7-1] The OLT shall be capable of requesting and receiving transmission status (including data buffer, communication environment) from any device in the F5G-A access network and the on-premises network, including the P-ONU and the E-ONU.

The OLT shall be capable of configuring the transmission behaviour of any device including the optical transmission parameters in the optical F5G-A access network and the on-premises network, or the air interface of the LAN (WLAN).

- [R7-2] The OLT shall be capable of configuring the transmission behaviour of any device in the F5G-A access network and the on-premises network.
- [R7-3] The P-ONUs shall be capable of providing local control for the E-ONUs and the corresponding end user devices through a centralized control mechanism.

One way to achieve unified control of the data transmission in both the F5G-A access network segment and the on-premises network segment, is to enable the OLT with direct control of each E-ONU by using OMCI extensions. Alternatively the P-ONU acts as an OMCI proxy or the use of upper layer protocols from the OLT to control the E-ONUs while the on-premises fibre network uses WMCI [i.12] and FMCI [i.11] between P-ONU and E-ONU for management and control.

- [Gap7-1] The OLT direct collection of the E-ONU's transmission status is currently not available.
- [Gap7-2] The OLT support for the direct configuration of each E-ONU is currently not available.
- [Gap7-3] None.

4.8.2.3 Provide unified management of the whole system

The management of the F5G-A access devices and the on-premises devices can be achieved through different methodologies. The ONU is managed and configured through OMCI based on the PON connection. The ONU or P-ONU could also be managed through IP based protocol like BBF TR-069 [i.14] or BBF TR-369 [i.15]. Proprietary solutions are also used to manage the E-ONU through the P-ONU. The coexistence of multiple protocols adds complexity to achieving global optimization in terms of management.

The F5G-A optical access network and the on-premises network shall support an extension of the OMCI management interface to enable global management of any device in the F5G-A access network and the on-premises network.

- [R7-4] The F5G-A optical access network and the on-premises network shall support an extension of the OMCI management interface.
- [R7-5] The unified management system shall support the management coordination between OLT and P-ONUs.

- [R7-6] The unified management system shall support a single management protocol for both the F5G-A access network devices and the on-premises network devices.
- [R7-7] The unified management shall support the collection of device information from the different network elements once they are connected by optical fibre.

The unified management shall provide visualization of the logical link for the different service flows, to enable a clean mapping between service flows and scheduling strategy.

- [R7-8] The unified management shall provide visualization of the logical links for the different service flows.

One way to achieve unified management of both the F5G-A access network segment and the on-premises network segment, is to enable the OLT with direct management of each E-ONU by using an extended OMCI. Alternatively, the P-ONU acts as an OMCI proxy of the OLT to manage the E-ONUs. In this case, additional Management Entities (MEs) need to be defined in the P-ONU.

- [Gap7-4] The extended OMCI management interface to enable global management of any device in the F5G-A access network and the on-premises network is currently not supported by the OLT.
- [Gap7-5] The unified management system between the OLT, the P-ONUs and E-ONUs is currently not supported.
- [Gap7-6] The protocol for device information collection based on a single protocol is currently not available.

The current OLT can only directly collect device information from P-ONUs through OMCI, the direct collection of device information for both the P-ONU and E-ONUs is not supported.

- [Gap7-7] The direct collection of device information for both the P-ONU and E-ONUs is currently not supported.
- [Gap7-8] The management system providing visualization of the logical link for the different service flows via the OLT OMCI is currently not supported.

4.8.3 Current related standard specifications

4.8.3.1 ITU-T SG15

In order to study control and management for a unified access and on-premises network, a joint project ITU-T draft G.Sup.CMAFP [i.17] was initiated in the 2023 ITU-T SG15 December plenary. This new project intends to study use cases, requirements, network architectures, and technical solutions together with protocols for a coordinated management system that covers both the access and the on-premises fibre networks. Capabilities for fibre on-premises control and management are expected to be provided, with enhancement to the current solutions. This project acts as a guideline to realize a better integrated PON and on-premises management system.

Future standard activity may result from this supplement document for access (PON recommendations, such OMCI) or on-premises (FTTR recommendations, like management specification of G.fin or WMCI [i.12]).

4.8.3.2 ETSI ISG F5G

To have QoE on-demand networks, accurate determination for dynamically allocating or assigning network resource is important. The work item on computing collaboration in ETSI GS F5G 025 [i.18].

ETSI GS F5G 025 [i.18] will specify the architecture framework for computing collaboration in the PON network. It will also specify the requirements of computing collaboration in the PON network, the key computing functions and the capabilities of each component in the PON network.

4.9 OTN intelligent fault management

4.9.1 Use Case Briefing

Fault management is one of the most important operation tasks for the network operators. Traditional OTN networks use an alarm-based fault management approach. A single network fault may result in a large number of alarms, which produces a large number of complex manual operations. The root cause analysis of the fault condition is required before the true fault can be determined and repaired.

In F5G-A, the incident-based intelligent fault management approach is used, to automatically analyse the alarm information, determine the actual network fault and generate the necessary recovery procedure. See Use Case # 8 in ETSI GR F5G 020 [i.1] for more details.

4.9.2 Technology Requirements and Gap Analyses

4.9.2.1 General

In the OTN intelligent fault management scenario, when receiving alarms from the OTN Network Elements (NEs), the OTN intelligent fault management system will determine the root alarm from among the multiple correlated alarms, and perform fault diagnosis to identify the root cause which generated the root alarm and the multiple correlated alarms. Such root alarm and the correlated alarms triggered by the same root cause are aggregated as an incident. See Figure 7, which is from ETSI GR F5G 020 [i.1].

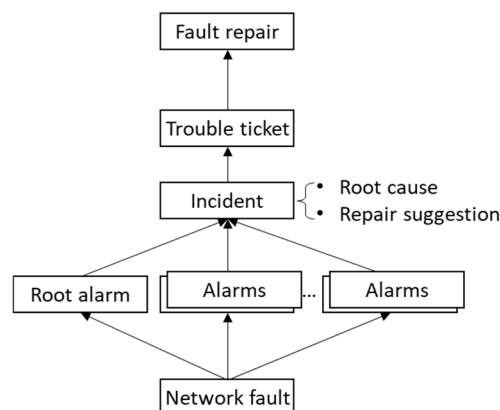

Figure 7: Incident-based fault management
(Source: ETSI GR F5G 020 [i.1])

Furthermore, the OTN intelligent fault management system analyses the impact on the OTN by the identified incident, and provides fault repair recommendations to the network administrator.

The OTN intelligent fault management system reports the identified incident information to the network administrator.

4.9.2.2 OTN alarm aggregation

When a failure occurs in the OTN, the OTN intelligent fault management system shall receive alarms from each of the NEs that are affected by the fault.

The OTN intelligent fault management system shall support the identification of an incident from a set of correlated alarms. The OTN fault management system will perform the alarm aggregation to identify the root alarm that triggered the other correlated alarms.

[R8-1] The OTN intelligent fault management system shall support collecting alarm information from the OTN NEs.

[R8-2] The OTN intelligent fault management system shall support root alarm identification from the received alarms.

Recommendation ITU-T G.874 [20] defines the management aspects of NEs in the OTN, including the OTN fault management which allows the NEs in OTN to report fault information to the Element Management Layer (EML) Operations System (OS).

Currently there is no related standards describing the identification of the root alarm when receiving a set of correlated OTN alarms.

[Gap8-1] None.

[Gap8-2] Root alarm identification from the aggregated alarm reporting is currently not supported.

4.9.2.3 Troubleshooting

Based on the root alarm information, the OTN intelligent fault management system shall perform fault diagnosis to identify the root cause which led to the occurrence of a set of correlated alarms.

The OTN intelligent fault management system should provide fault repair recommendations, which can be used to guide the network administrators to handle the network faults.

[R8-3] The OTN intelligent fault management system shall support OTN root cause analysis based on a set of correlated alarms.

[R8-4] The OTN intelligent fault management system should support providing fault repair recommendations.

The OTN root cause analysis and fault repair recommendations are currently not specified in OTN related standards.

[Gap8-3] OTN root cause analysis is currently not supported.

[Gap8-4] The provisioning of OTN fault repair recommendations is currently not supported.

4.9.2.4 Fault impact analysis

Once the root cause is identified, the OTN intelligent fault management system shall analyse its impact on the OTN, including the OTN link resources and the OTN connection services which are affected by the faults.

When multiple faults occur in parallel, the OTN intelligent fault management system should provide the fault handling priorities based on the severity of the impact on the network. This is used to guide the network administrators about the best sequence for handling multiple faults.

[R8-5] The OTN intelligent fault management system shall support fault impact analysis.

[R8-6] The OTN intelligent fault management system should support providing fault handling priorities.

The OTN fault impact analysis and fault handling priorities are not specified in the current OTN related standards.

[Gap8-5] OTN fault impact analysis is currently not supported.

[Gap8-6] The provisioning of OTN fault handling priorities is currently not supported.

4.9.2.5 Report of incident information

The OTN intelligent fault management system shall report the identified incident information to the network administrator. Typical such incident information will be sent to the operator's trouble ticket dispatching system.

[R8-7] The OTN intelligent fault management system shall support reporting the identified incident information.

The reported incident information shall support at least the following elements:

- Root cause.
- Alarm correlation information.
- Fault location.

- Fault occurrence time.
- The impact of the fault.
- The fault severity.
- Handling priority.
- Repair recommendations.

[R8-8] The reported incident information shall support at least the elements listed above.

IETF started discussing the YANG model for OTN configuration and management, covering the Fault, Configuration, Accounting, Performance and Security (FCAPS). The detail fault management models are to be further discussed and defined.

[Gap8-7] The information report of an identified incident is currently not supported.

[Gap8-8] The YANG models for the information report of an identified incident are currently not supported.

4.9.3 Current related standard specifications

4.9.3.1 ITU

Recommendation ITU-T G.874 [20] addresses the management aspects of the OTN NEs, and describes the management network organizational model for communication between an EML OS and the optical Equipment Management Function (EMF) within the NEs in OTN. Fault management is one of the important parts in this recommendation.

4.9.3.2 IETF

IETF defines the Abstraction and Control of Traffic Engineering (TE) Networks (ACTN) architecture and the related YANG models for OTN control. IETF draft-ietf-ccamp-actn-optical-transport-mgmt [i.19], which is under development, proposes to integrate the YANG model for OTN configuration and management into the ACTN system, covering the management of Fault, Configuration, Accounting, Performance and Security (FCAPS). The detail fault management models are for further discussion.

4.10 Evaluation and assurance of user service experience

4.10.1 Use Case Briefing

Residential and in general CPN broadband users have become increasingly sensitive to the application service experience. Potentially, the network operators may not be aware of the deterioration in the user's service experience, unless the user makes a complaint. Usually the service experience deterioration is manually resolved on-site, which takes time to fix the problem and increases OPEX.

In F5G-A, proactive evaluation and assurance of the user's experience, and fast identification and rectification of the service experience problems, is critical and needs to be taken into consideration. With the improvements in network automation capabilities, in some cases it is possible that the network operators can remotely fix the problems affecting the user's service quality, or can even optimize the network before the user experience deteriorates. This will greatly shorten the average diagnosis and rectification time of service quality problems, reducing the on-site service rate, saving OPEX, and improving user satisfaction. See Use Case # 9 in ETSI GR F5G 020 [i.1] for more details.

4.10.2 Technology Requirements and Gap Analyses

4.10.2.1 General

To support the evaluation and assurance of user service experience, an F5G-A Access Network QoE analysis system is introduced in the Access Network, see Figure 8. The key capabilities of the F5G-A Access Network QoE analysis system include real-time evaluation of user's service experience, precise demarcation and root cause analysis of poor-QoE problems when applicable, and automatic rectification and regular audits of potential poor-QoE problems.



Figure 8: Overview of the F5G-A Residential broadband QoE evaluation and assurance (Source: ETSI GR F5G 020 [i.1])

4.10.2.2 Evaluation of user's service experience

To objectively evaluate a user's service experience, a user experience evaluation model shall be established, which is based on the network KQIs that the users are aware of.

[R9-1] The user experience evaluation model shall be defined.

To evaluate whether a specific user suffers from poor-QoE problems, the F5G-A Access Network QoE analysis system shall obtain the KQIs of the typical F5G-A residential services, and form the normalized and quantified service experience indicator based on the user experience evaluation model.

The typical F5G-A residential services include telephony, web browsing, data upload and download, IPTV, on-line gaming, on-line education/telework, and cloud VR.

The F5G-A Access Network QoE analysis system shall also obtain the F5G-A Access Network KQIs/KPIs, and analyse the network KQIs/KPIs on both the time dimension and the network segment dimension.

[R9-2] The F5G-A Access Network QoE analysis system shall collect the F5G-A Access Network service and network KQIs.

ETSI GS F5G 015 [21] specifies the service quality evaluation of the typical F5G-A residential services. It uses the concept of Mean Opinion Score (MOS) values, to score the service KQIs on a per-KQI, and per-service level. In this way, the user experience evaluation model is established.

[Gap9-1] None.

ETSI GS F5G 017 [22] specifies the measurement methodologies to evaluate the quality of residential network services and network characteristics/functionalities based on the service and network KQIs defined in ETSI GS F5G 015 [21].

ETSI GS F5G 026 [23] defines the system architecture for residential service quality monitoring (including the service KQIs and the network KQIs) based on ETSI GS F5G 017 [22]. The corresponding technical requirements, interfaces and data models for the service KQI monitoring are also specified.

[Gap9-2] The protocol specification for the interface to obtain the F5G-A Access Network service and the network KQIs is currently not supported.

4.10.2.3 User experience demarcation and root cause analysis

The F5G-A Access Network QoE analysis system shall analyse the network KQIs/KPIs on both the time dimension and the network segment dimension, and perform the root cause analysis of the poor-QoE problems, to determine the exact location and the key factors that affect the users' service experience.

For the network segment, the network equipment and the exact location of the poor-QoE problems may be:

- The transport network or a content service network fault.
- The PON equipment or a component fault, including card, optical module, port, ONU, FTTR P-ONU or E-ONU problems.
- The ODN feeder fibre and the distribution fibre problems.
- The CPN network problems, including the Wi-Fi® air interface interference or connection problems, an Ethernet cable problem, or an ONU/AP configuration exception.

Based on the previous analysis, the F5G-A Access Network QoE analysis system shall provide a list of users who are considered to have, or potentially will have service experience problems.

[R9-3] A portal to the F5G-A Access Network QoE analysis system should be provided to report the location and the key factors affecting the user's service experience.

[R9-4] A portal to the F5G-A Access Network QoE analysis system should be provided to report the users who are considered to have, or potentially will have service experience problems.

Currently, there is no standard interface for the F5G-A Access Network QoE analysis system to report the fault location information and the list of users who are considered to have, or potentially will have service experience problems to the management and control system.

[Gap9-3] The F5G-A Access Network QoE analysis system interface that provides the location and the key factors that affect the user's service experience to the management and control system is currently not supported.

[Gap9-4] The F5G-A Access Network QoE analysis system interface that provides the list of users who are considered to have, or will potentially have service experience problems to the management and control system is currently not supported.

4.10.2.4 User experience rectification and audit

If the F5G-A Access Network QoE analysis system determines that there are software problems causing service experience problems, it shall automatically reconfigure the network element(s) to resolve the software problems.

NOTE: A software problem refers to a software issue on a network element that maybe resolved by a software update or network element reconfiguration, without the need for hardware change. An example could be incorrect configuration of the Wi-Fi® antenna, causing transmit power to be too low.

[R9-5] The F5G-A Access Network QoE analysis system shall support automatic reconfiguration of the Access Network element(s) to resolve software problems that cause service experience problems.

If the F5G-A Access Network QoE analysis system determines that service experience problems need to be resolved by manual on-site service, it shall support dispatching the trouble tickets to the network operator.

[R9-6] The F5G-A Access Network QoE analysis system shall support dispatching the user service experience problem trouble tickets.

The F5G-A Access Network QoE analysis system shall re-evaluate the user's experience after user issue rectification, to see if the problems have been resolved. The technical requirements of the re-evaluation are the same as that of the user's service experience evaluation.

Currently, there are no standards describing how an F5G-A Access Network is reconfigured to resolve software problems that cause service experience problems, or how the user's service experience problems trouble tickets are dispatched.

[Gap9-5] The automatic reconfiguration of the F5G-A Access Network to resolve software problems that cause service experience problems is currently not supported.

[Gap9-6] The trouble ticket or maintenance ticket dispatching, when a user's QoE problem or potential problem are detected by the F5G-A Access Network QoE analysis system, is currently not supported.

4.10.3 Current related standard specifications

4.10.3.1 BBF

BBF defines the Access Network YANG models, including BBF TR-383 [i.20] and BBF TR-385 [i.21], and other standards related to other type of Access Network systems. BBF is also working on the northbound interface of the Access SDN Management and Control (M&C), for Access Network build and service fulfilment. See BBF WT-411i2 [i.22] and BBF WT-454i2 [i.23].

4.10.3.2 ETSI

ETSI ISG F5G specified the service quality evaluation of the typical F5G-A residential services in ETSI GS F5G 015 [21], and specified the measurement methodologies to evaluate the quality of residential services in ETSI GS F5G 017 [22]. ETSI ISG F5G also specified the system architecture for residential service quality monitoring in ETSI GS F5G 026 [23]. The root cause analysis of the residential service experience problems and the user experience rectification still need further study.

4.11 Cloud Desktop

4.11.1 Use Case Briefing

Cloud desktop is a desktop virtualization platform allowing users to access Windows like desktops or applications that are running in a different physical location. This E2E system includes multiple functional blocks, such as server in the data centre, data processing algorithm for rendering, encoding, framing, etc. and the network for data transmission. The cloud desktop service provides efficient sharing of hardware in the cloud and quick service provisioning. This enables flexible arrangement of hardware/software resources for any innovative applications. See Use Case # 10 in ETSI GR F5G 020 [i.1] for more details.

4.11.2 Technology Requirements and Gap Analyses

4.11.2.1 General

The cloud desktop service forwards real-time video streaming since the local device is simplified, containing no data buffer and processing units. The dynamic interaction with the desktop by end user requires low latency in the network. To fulfil the cloud desktop requirements, an edge cloud infrastructure needs to be introduced to reduce the transmission latency by reducing the physical distance between the cloud server and the end device, helping to off-load computing needs. In addition, network intelligence such as service identification or network slicing is essential to guarantee cloud services. To further reduce the processing delay, the encoding/decoding complexity should be simplified, therefore, shallow compression and low-delay codec solutions (exchange throughput for computing and latency) need to be considered.

4.11.2.2 Edge cloud infrastructure

The F5G-A network enables distributed computing functions. To support lower transmission latency, an edge cloud infrastructure should be adopted to reduce the physical distance between the server and the end user.

[R10-1] The Edge cloud infrastructure shall be deployed close to the end user to support low latency data transmission in a F5G-A network.

[R10-2] The Edge cloud should support coordination with the remote cloud to enable the best service QoS for the end user.

The transmission speed of light in optical fibre is approximately 200 000 km per second. So, 2 000 km transmission distance needs 10 ms transmission time. In IP network, the switching time and additional processing in multiple network nodes will add significant time delay to the cloud desktop service. The F5G-A one-hop OTN shall enable transmission delay close to the optical limit. The edge cloud infrastructure solution is based on and should leverage the mature cloud technologies and OTN.

Having several cloud infrastructures providing cloud application services necessitates the need for computing coordination. The computing coordination between F5G-A network elements is necessary.

[Gap10-1] None.

[Gap10-2] The computing coordination mechanism between different F5G-A network elements is not currently available.

4.11.2.3 Enable intelligence in the network

The end user QoE using cloud desktop is affected by the network performance. The end user generally interacts continuously with the cloud desktop, lasting for a period of time for work, entertainment, or other web activities. This requires a network with stable performance. Therefore, the cloud desktop service should be recognized and allocated a high service priority in terms of network communication. This can be achieved by analysing the data streaming characteristics by using AI or can be directly configured by the cloud desktop provider.

[R10-3] The F5G-A network shall support cloud desktop service identification and support the assignment of service priority.

The F5G-A network shall support slicing technology (including intelligent packet offloading/processing/forwarding based on the service priority, the slicing in F5G-A optical network and the Wi-Fi® network) to guarantee network QoS for cloud desktop service delivery.

[R10-4] The F5G-A network shall support slicing technology and guaranteeing network QoS for cloud desktop service delivery.

The AI model of service recognition is not available and is determined by the implementation and the network infrastructure. It is typically based on system vendor internal functionality and difficult for standardization. The training of an AI model is based on machine learning algorithms and available network data profiles. For the network slicing capability, ETSI GS F5G 013 [11] has pointed out the gap for different network segments.

[Gap10-3] The F5G-A network adaptation mechanism to the variation of network demand due to the cloud desktop service is currently not available.

The E2E slicing technologies are defined in clause 5.4.1 of ETSI GS F5G 014 [3] for OTN, PON and Wi-Fi® slicing.

[Gap10-4] None.

4.11.2.4 Shallow compression techniques

Cloud desktop is a strongly interactive network service. Deterministic low latency is a key network characteristic for guaranteeing the user QoE in the continuous interactive activities like clicking the mouse, open files, download/upload, and other cloud desktop interactive activities. To further reduce transmission latency, shallow compression techniques should also be considered. Simplified encoding and decoding processes increase the network capacity demand but decrease the processing time of the data. Moreover, parallel processing of the cloud desktop services using network slicing technology provides additional benefits for data processing.

[R10-5] Shallow compression techniques with low compression ratio shall be supported by Cloud desktop technology.

[R10-6] Independent encoding and decoding processes for shallow compression of each frame shall be supported by Cloud desktop technology.

[R10-7] The F5G-A system shall support parallel compression for cloud desktop service slices.

MPEG [24] is a widely used compression technology enabling the I-frame to convey the main content, with B/P-frame conveying the delta to previous frames. This creates a large compression ratio (typically 1:300) with the drawback of triggering correlation between consecutive frames, introducing processing latency. This methodology also produces I-frame throughput bursts, creating throughput demand variation in the time domain. Therefore, to achieve lower processing latency, it is better to enable independent and efficient pipeline encoding and decoding procedures for each frame.

[Gap10-5] Shallow compression techniques with a low compression ratio is currently not available.

[Gap10-6] Independent encoding & decoding for each data frame is currently not available.

[Gap10-7] Parallel compression for cloud desktop service slices is currently not available.

4.12 Dynamically digitalized ODN

4.12.1 Use Case Briefing

The Optical Distribution Network (ODN) is the core infrastructure of FTTx access networks, where x is R, H, M, O [i.24]. With the large-scale deployment, the secure operation and fast fault locating of the ODN infrastructure have become one of the top concerns for service providers and end users. The ODN resource management is the main challenge and the unavoidable issue for service providers. In case of natural disaster like earthquake, or unexpected ODN damage caused by animals in the outdoor environment, a fast or dynamic methodology to show the physical fibre topology is important.

With a dynamically digitalized ODN, it is possible to proactively and periodically inspect the ODN. The dynamic information of the ODN could be collected. This information could include new physical parameters as input for an AI algorithm to perform fault prediction, fault detection and fault recovery. See Use Case # 11 in ETSI GR F5G 020 [i.1] for more details.

4.12.2 Technology Requirements and Gap Analyses

4.12.2.1 General

Dynamically digitalized ODN requires quantitative and dynamic visualization of the ODN, providing new capability to accurately parameterize the ODN, and regularly monitoring the ODN status. The ODN diagnostics and fault recover are very beneficial to network operators. The system shall provide functions including real-time and quantitative visualization of the resource status, facilitating precise capacity expansion, providing the digital twin with the practical ODN information, prudently and remotely locate faults, reducing service interruption duration and proactive inspection of optical path quality to ensure zero potential risks.

4.12.2.2 Dynamically visualization of ODN

Digitalized visualization of the different optical ODN components, includes fibre connectors, passive fibre splitters, path loss, are basic functions. Both the logical connection and physical locations of the ODN shall be displayed.

[R11-1] The digitalized ODN system shall support dynamic visualization of the ODN topology between the OLT and the ONU or P-ONU.

[R11-2] The digitalized ODN system shall support GIS-based location identification and visualization of the ODN.

[R11-3] The digitalized ODN system shall support the dynamic visualization of insertion loss for the different ODN segments.

The current ODN system only provides static ODN visualization. Any changes to the ODN cannot be dynamically monitored. The accurate physical location is not easily identified.

[Gap11-1] The dynamic visualization of the ODN topology is currently not available.

[Gap11-2] The physical location of the ODN is currently not available.

[Gap11-3] The dynamic collection of the ODN insertion loss is currently not available.

4.12.2.3 Proactively diagnostic and remote fault location

Dynamic collection of the ODN status provides the opportunity to determine an ODN failure if any. Therefore, proactive diagnostics and remote fault location can be achieved by analysing the potential connection problems. The proactive optical path diagnostics need to support optical attenuation fault location of the connection, optimize weak optical signals, and rectify the risk to the optical connection (including abnormal optical attenuation in advance and identify frequent fault points).

[R11-4] The digitalized ODN system shall support proactive optical path diagnostics.

[R11-5] The digitalized ODN system shall support remote fault locating within 15 minutes.

Manual inspection of ODN faults is time-consuming and inefficient in finding faults. The customer needs a stable and reliable network connection.

[Gap11-4] Proactive diagnostic and recovery of ODN faults are currently not available.

[Gap11-5] Dynamic remote fault location determination is currently not available.

4.12.2.4 ODN resource management

ODN resource visualization helps to better understand the fault types. The ODN resource management includes visualization of level 1 optical splitter status (branching to another optical splitter), direct connection to the ONUs/P-ONUs, suspended optical fibre that are not being used, fibre connection status for various ONUs/ P-ONUs, the connection between splitter ports, or the splitter port and the ONU or P-ONU. The ODN resource management status collection includes fibre connection status, splitter connection status, and ONU or P-ONU connection status.

[R11-6] The digitalized ODN system shall support ODN resource status collection.

Considering the large-scale deployment of FTTx-ODNs around the world where x is R, H, M, O [i.24], the dynamically digitalized ODN aims to improve ODN deployment and management efficiency.

[Gap11-6] ODN resource management is currently not available.

4.12.3 Current related standard specifications

4.12.3.1 Current ODN related standards

For current related standard specification references see ETSI F5G GS 013 [11], clause 4.12.3.

4.13 On-premises Millimetre-Wave (mmWave) WLAN

4.13.1 Use Case Briefing

Millimetre wave Wi-Fi® suffers from significant signal absorption loss by obstacles, including door, wall, and other enclosures that cause signal absorption, which generates on premise Wi-Fi® signal isolated regions. In this case, FTTR enabling full fibre coverage is the best backhauling network for mmWave Wi-Fi®, capable of supporting high throughput, bounded latency and low packet jitter for each AP per room. For an example of practical usage see Figure 9, sub-6 GHz Wi-Fi® enables link connections for corner region while mmWave Wi-Fi® provides collision-free connections for devices requiring high quality connections. See Use Case # 12 in ETSI GR F5G 020 [i.1] for more details.

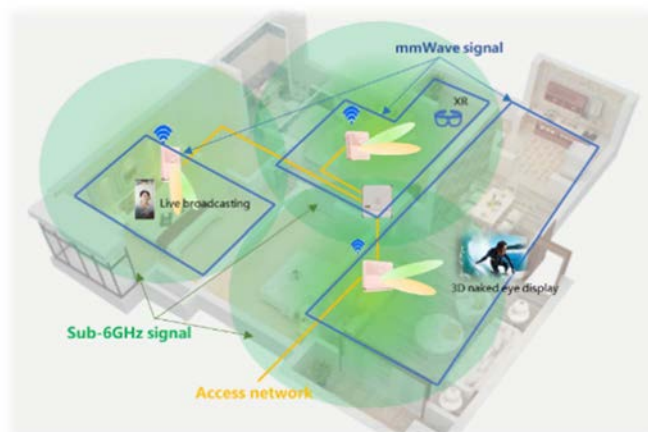

Figure 9: An example of mmWave WLAN network

4.13.2 Technology Requirements and Gap Analyses

4.13.2.1 General

The on-premises mmWave WLAN over FTTR shall support the typical F5G-A network services, enabling 10 Gbps on-premises connections to everywhere. On-premises mmWave WLAN over FTTR provides extremely high-quality connections without any packet collisions compared to the traditional Wi-Fi® technology. To coexist with the widely deployed Wi-Fi®, coordination is necessary enabling link switching, which is required for handover, and to improve signal quality issues.

FTTR technologies are specified in ITU-T SG15 Q3 while mmWave Wi-Fi® is mainly developed by IEEE 802.11.

4.13.2.2 Provide necessary throughput to support F5G-A applications

The typical F5G-A network services to be supported includes extended reality, metaverse, digital twins and industrial optical networks, ETSI GR F5G 021 [i.24]. 10 Gbps FTTR and Wi-Fi® 7 are the primary technologies for F5G-A, enabling 10 Gbps on-premises to everywhere through fibre connections. The new mmWave Wi-Fi® specification is currently under study in IEEE 802.11bq [i.29] MMW SG (mmWave Study Group). Therefore, it is also expected that the mmWave Wi-Fi® for each AP is capable of supporting at least 10 Gbps throughput.

[R12-1] The mmWave Wi-Fi® shall support 10 Gbps throughput on the air interface in the unlicensed V-band and Q-band.

The previous mmWave Wi-Fi® technologies, including IEEE 802.11ad [i.25], IEEE 802.11aj [i.26] and IEEE 802.11ay [i.27], support larger than 10 Gbps data rate. These standards are not aligned with the sub-6 G Wi-Fi®. Therefore, deployment is challenging due to the complexity. On the other hand, based on the multi-link operation feature in Wi-Fi® 7, it is possible to simultaneously have multiple link connections at different frequency. This triggered the IEEE community to re-think leveraging the current sub-6 GHz technology for mmWave Wi-Fi®. Currently, the detailed specifications are under study.

[Gap12-1] The sub-6 GHz alignments with mmWave Wi-Fi® technology is currently not available.

4.13.2.3 Well controlled Wi-Fi® signals to support interference free connection

To enable a quality-assured link, the Wi-Fi® air interface between AP and STA shall be well coordinated. For example, IEEE 802.11ad [i.25] supports time division multiplexing to perform scheduling so as to avoid collision. In addition, the Wi-Fi® transmission power shall be well controlled although signal loss in walls is high for mmWave technology. To achieve wider coverage and high SNR, beamforming technology is widely used in mmWave Wi-Fi® in order to have high antenna gain in both the transmission and reception. The control and feedback of the power in mmWave is important. A balance or compromise needs to be considered between mitigating interference and maintaining a good quality link within a single room.

- [R12-2] The mmWave Wi-Fi® shall support a coordinated transmission mechanism to avoid packet collision in the air interface (i.e. within a single BSSID).
- [R12-3] The mmWave Wi-Fi® over the FTTR system shall be capable of sensing the signal distribution of each AP and control the transmission power to mitigate interference between rooms.

To achieve an interference free air interface, it is required that the whole on premises network system shall be capable of collecting the signal distribution status and perform adjustments accordingly.

The coordinated transmission mechanism is supported by IEEE 802.11ad [i.25], IEEE 802.11aj [i.26] and IEEE 802.11ay [i.27]. For the new 6 GHz Wi-Fi® aligned system, the new specification is under study.

- [Gap12-2] The coordinated transmission mechanism supporting the new 6 GHz aligned system specification, is currently unavailable.

The data model for Wi-Fi® devices are defined in Wi-Fi® Alliance (WFA) Data Element specification while the exchange of such information between different AP is managed by FMCI [i.11] or WMCI [i.12] for FTTR system, which is still under development.

- [Gap12-3] The data model for Wi-Fi® devices is currently unavailable.

4.13.2.4 Coordination with sub-6 G Wi-Fi®

Widely deployed sub-6 G Wi-Fi® operates on unlicensed band including 2,4 GHz, 5 GHz, and 6 GHz, providing ubiquitous connectivity. Although using mmWave Wi-Fi® could create isolated region over FTTR. With mmWave Wi-Fi® some issues may occur while users cross the boundaries between regions, including moving from one room to the other, blockage of furniture or other object. These scenarios may cause signal strength variation if the line-of-sight link is blocked or may cause link switching between different APs in the handover procedure. This will require that the mmWave Wi-Fi® shall coordinate with the sub-6 GHz Wi-Fi® in coexistence scenarios.

- [R12-4] The mmWave Wi-Fi® over FTTR system shall provide a coordination scheme with sub-6 GHz Wi-Fi® to maintain the quality of connection during link switching within a single AP and link switching between different APs.

The sub-6 GHz Wi-Fi® should be capable of assisting the mmWave Wi-Fi® with beamforming, beam tracking and link adaptation in order the maintain the link quality.

- [R12-5] The sub-6 GHz Wi-Fi® should support the mmWave Wi-Fi® by assisting with beamforming, beam tracking and link adaptation.

The sub-6 GHz Wi-Fi® should be capable of transmitting the necessary link control information for mmWave Wi-Fi® to reduce any potential latency of the network services.

- [R12-6] The sub-6 GHz Wi-Fi® should support mmWave Wi-Fi® link control information transport.

With the assistance of sub-6 GHz Wi-Fi®, the mmWave Wi-Fi® link will become more robust providing high quality links for dedicated region over the FTTR solution. However, many of the coordinating technologies between sub-6 GHz and mmWave Wi-Fi® are new topics and are under study.

- [Gap12-4] The coordination mechanism between sub-6 GHz and mmWave Wi-Fi® for link switching is currently not available.

- [Gap12-5] The assistance mechanism of sub-6 GHz Wi-Fi® for mmWave Wi-Fi® for beamforming, beam tracking and link adaptation is currently not available.

- [Gap12-6] The separated control and data plane for mmWave Wi-Fi® through sub-6 GHz Wi-Fi® is currently not available.

4.13.3 Current related standard specifications

4.13.3.1 ITU-T SG15

The specifications for the FTTR system are defined in ITU-T SG15 Q3. For the FTTR standardization progress, refer to clause 4.3.3.1 in the present document.

4.13.3.2 IEEE 802.11

The radio frequency spectrum is limited and regulated by ITU-R for global harmonization. In particular, the usage of low frequency bands could be different between countries. To explore higher frequency bands and have more channel bandwidth, V-band (around 60 GHz) and Q-band (around 45 GHz) are released for unlicensed usage globally depending on the regional policy. Based on that, the IEEE 802.11ad [i.25], which is an amendment to the IEEE 802.11 standards, providing a Multiple Gigabit Wireless System (MGWS) in the 60 GHz frequency band. Beamforming and larger channel bandwidth are available, enabling the data transmission rate of up to 7 Gbps. This will support various new applications like uncompressed UHD video transmission (as a replacement of HDMI), cloud VR, etc. over the wireless network. The IEEE 802.11ad [i.25] standard defines six different 2 160 MHz channels in the frequency range from 57 GHz to 71 GHz.

To further boost the maximum data rate, the amendment of IEEE 802.11ad [i.25], IEEE 802.11ay [i.27] introduces channel bonding technology to make use of the full bandwidth resources, such as 4 channel integration to 8,64 GHz bandwidth. Multiple Input Multiple Output (MIMO) is also specified with up to maximum of 4 data streams. The link-rate per stream can reach up to 44 Gbps, with four streams reaching up to 176 Gbps. Higher order QAM modulation (256 QAM) is also considered based on the evolution of RF technology in mmWave.

China issued 42 GHz to 48 GHz frequency band (Q-band) for WLAN usage. To adapt this frequency band, IEEE developed a regional amendment of 802.11 standards, IEEE 802.11aj [i.26]. This standard mainly implements MIMO with a maximum channel bandwidth of 1,08 GHz within the band and 4 data streams to support a data rate of up to 15 Gbps.

To leverage the sub-6 GHz technology, IEEE 802.11bq [i.29] recently initiates a study group, "Integrated mmWave" (IMMW), to discuss re-using the sub-6 GHz baseband for MMW based on multi-link operation technology. The scope of this study group is to support non-standalone operation in the unlicensed bands between 42 GHz and 71 GHz using Single-User (SU) OFDM based transmissions. The project also supports at least one of the 2,4 GHz to 7,25 GHz (sub-7 GHz) unlicensed bands. The coexistence mechanisms with legacy IEEE 802.11 devices operating in the unlicensed bands between 42 GHz and 71 GHz is expected to be provided. The study group is still on-going in the IEEE 802.11bq [i.29]. Further technical group may be created according to the convergence of the scope.

4.14 Wavelength-shared WDM Aggregation Network (AGGN)

4.14.1 Use Case Briefing

With the acceleration of optical CPN broadband speed and digital economy requirements, Aggregation Networks (AGGNs) are being developed with low cost and complexity, high flexibility and automation. The current connections between aggregation nodes and multi-service access nodes are typically in rings or chains with grey optics, optical fibre direct connections or Fixed Optical Add/Drop Multiplexer (FOADM). All these approaches suffer from low wavelength resource utilization, poor network flexibility, high cost and complex network O&M. It is recommended that the ring connections between the aggregation nodes and multi-service access nodes deploy Reconfigurable Optical Add-Drop Multiplexer (ROADM) supporting wavelength-sharing between the different rings, which satisfies the requirements of the future AGGN. See Use Case # 13 in ETSI GR F5G 020 [i.1] for more details.

4.14.2 Technology Requirements and Gap Analyses

4.14.2.1 Network bandwidth

End-to-end wavelength-shared WDM AGGNs introduce huge bandwidth demand due to the increasing requirement from different business scenarios (to Customer (to C) / to Home (to H) / to Business (to B)). To meet the increased capacity requirements, there are two potential approaches the first is to increase the bandwidth per channel, the second is to increase wavelength resource utilization, enabling wavelength sharing between different rings.

The combination of these two approaches imposes the following bandwidth requirements:

- [R13-1] The wavelength-shared WDM AGGN shall support the smooth evolution to higher data rate beyond 200 G per channel.
- [R13-2] The wavelength-shared WDM AGGN shall support efficient utilization of wavelength resources.

Physical layers and management parameters for 100 Gbps and 400 Gbps operation over DWDM systems are defined by IEEE 802.3 [26]. 800 Gbps interfaces are standardized in Recommendation ITU-T G.709.6 [15] and IEEE 802.3 [26]. However, the wavelength-sharing feature for improving wavelength resource utilization in AGGNs is missing.

[Gap13-1] None.

[Gap13-2] Standard for wavelength sharing between different rings in wavelength-shared WDM AGGN is currently not defined.

4.14.2.2 Multiple-ring network and long-haul transmission distance

Typically, AGGN connects aggregation nodes and multiple multi-service access nodes in a multiple-ring structure, where each ring connects multiple multi-service access nodes. For this scenario each aggregation node connects to between four to eight rings, and one ring connects to between four and eight multiple multi-service access nodes, as can be seen in Figure 10. A transmission distance up to 320 km is then required based on this connection scenario without optical-electronic-optical conversions.

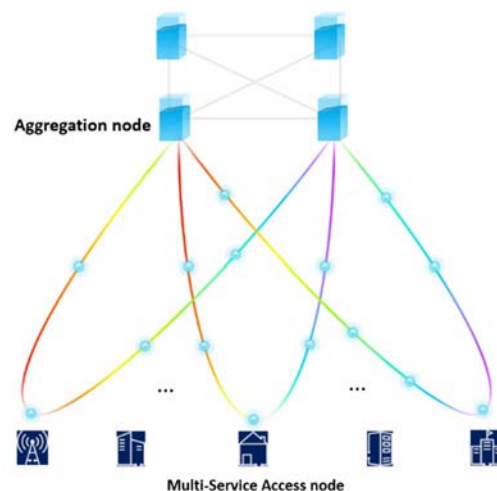

Figure 10: Wavelength-shared AGGN configuration

[R13-3] The wavelength-shared WDM AGGN shall support a multiple-ring multi-service access network structure with the reuse of wavelengths per AGGN node.

[R13-4] The wavelength-shared WDM AGGN shall support an all optical transparent connection up to 320 km.

The DWDM metro applications including optical amplifiers have been standardized in Recommendation ITU-T G.698.2 [25], where "black links" include two or more OADMs connected in a ring. However, the characteristics of this multiple-ring multi-service access network structure are missing.

[Gap13-3] The multiple-ring multi-service access network structure standard is currently not supported.

[Gap13-4] None.

4.14.2.3 Flexible grooming capability

The key features for the various types of business scenarios (to Customer (to C) / to Home (to H) / to Business (to B), and cloud computing) in the AGGN include different bandwidth granularity requirements (2 Mbps to 100 Gbps), and a large number of services (tens of thousands of services on each local network). Therefore, the AGGN requires high flexibility depending on the different scenarios.

The ROADM technique supports optical-layer flexible spectrum spacing, flexible wavelength allocation, wavelength switching and grooming. ROADMs reduce the number of boards, space, and power consumption of AGGN equipment by replacing multiple FOADM for different rings per aggregation node.

While fine grain OTN (fgOTN) is compatible with the existing OTN architecture, it is oriented to a wide range of service bandwidth granularities, thus achieving aggregation and flexible grooming of 2 Mbps to 100 Gbps bandwidth granularity in the electrical layer.

- [R13-5] The wavelength-shared WDM AGGN should support optical-layer wavelength grooming.
- [R13-6] The wavelength-shared WDM AGGN should support dynamic allocation of bandwidth granularity.

The classification and the characteristics of Multi-Dimensional Reconfigurable Optical Add/Drop Multiplexers (MD-ROADMs) has been standardized in Recommendation ITU-T G.672 [28]. However, Recommendation ITU-T G.672 [28] cannot meet the wavelength-shared WDM AGGN requirements in terms of functionality, integration, and power consumption. A standard is needed to define a new functional model for integrated ROADM technique in wavelength-shared WDM AGGNs.

Currently OTN standard Recommendation ITU-T G.709/Y.1331 [1] defined the ODUflex container which enables OTN connections with flexible rate, furthermore Recommendation ITU-T G.7044/Y.1347 [29] defined hitless adjustment of ODUflex. Recommendation ITU-T G.709/Y.1331 [1], Annexes M and N also defined fgOTN technology as a flexible fine grain OTN container which enables OTN connections with flexible rate of N by 10 Mbps together with the hitless adjustment of fgOTN. CCSA has also defined OSU technology as a flexible optical service unit container which enables OTN connections with flexible rate from 2,6 M to 10 G, together with the hitless adjustment of OSU. IETF RFC 7139 [i.4] defined the signalling protocol for dynamical creation, deletion and adjustment of ODUflex connections.

- [Gap13-5] Standard for function model of integrated ROADM with higher integration, smaller size, lower power, is currently not defined.
- [Gap13-6] None.

4.14.2.4 Automatic network O&M

The large number of nodes and diverse service requirements of the AGGN necessitates simplified deployment and network O&M. The optical-layer digital label technique introduced in Use Case #13 [i.1] enables highly intelligent and automatic operations for initial deployment and the subsequent network O&M, which greatly reduces the Operating Expenses (OpEx).

Deployment: hardware installation requires only one site visit and the network management system automatically completes the Network Element (NE) ID and IP address configuration. Wavelength resources are automatically allocated and services are automatically commissioned, eliminating the manual site visit.

O&M: real-time monitoring and detection of single channel power, Optical Signal-to-Noise Ratio (OSNR), dispersion, polarization state, non-linear effect, and link margin are supported. This then enables real-time monitoring of services, fast remote fault demarcation, and automatic optimization after the link attenuation changes.

- [R13-7] The wavelength-shared WDM AGGN shall support real-time monitoring of single channels and transmission links.
- [R13-8] The wavelength-shared WDM AGGN shall support automatic allocation of wavelength resources and network optimization.

Recommendation ITU-T G.698.4 [30] has standardized remote performance monitoring techniques using a message channel for DWDM systems up to 10 Gbps and 20 km. This does not satisfy the requirements of wavelength-shared WDM AGGNs. Autonomous management and control functionalities have been specified in ETSI GS F5G 006 [31], which serves as a reference to standardize the O&M requirements for this use case.

- [Gap13-7] A performance monitoring standard for wavelength-shared WDM AGGN is currently not defined.
- [Gap13-8] An automatic network O&M standard for wavelength-shared WDM AGGN is currently not defined.

4.14.3 Current related standard specifications

4.14.3.1 ITU-T

ITU-T has standardized OTN interfaces from 100 Gbps to 800 Gbps, including multi-vendor client-side interfaces (2 km ~ 40 km grey optics), multi-vendor line-side interfaces (80 km for DCI and 450 km for metro), and single vendor line-side interfaces (1 500 km for long haul) [1], [12], [13], [14], [15]. Optical interface specifications up to 100 Gbps in DWDM applications have also been defined intended for metro applications with optical amplifiers in Recommendation ITU-T G.698.2 [25].

4.14.3.2 ETSI

The F5G Aggregation network topology and the interfaces have been defined in ETSI GS F5G 014 [3]. The aggregation network fabric, for both IP/Ethernet fabric and OTN fabric are introduced.

4.14.3.3 IEEE

IEEE has standardized Ethernet interfaces up to 400 GE in different application scenarios, such as SR/DR/FR/LR. ZR applications named "operation over DWDM systems" including 100 GE and 400 GE have also been specified in IEEE 802.3 [26]. An active work item on 800 GE and 1,6 Tbps Ethernet interfaces under 40 km is under discussion.

4.14.3.4 OIF

OIF is mainly focused on 80 km 400 G [27] and 10 km/80 km 800 G interfaces for DCI (LR/ZR), together with the management interface specifications.

4.15 Robotics as a Service

4.15.1 Use Case Briefing

This F5G-A use case aims to overcome the 'cloud barrier' in robotics, where low-level manufacturing tasks are performed at the edge and high-level functions are handled in the cloud. Current systems like the Robotic Operating System (ROS) supports multiprocessing but is hampered by latency issues between different compute units, particularly in motion control, affecting real-time responsiveness. F5G-A networks can significantly reduce this latency, allowing more efficient real-time control directly from the cloud, even across large manufacturing areas. This technology enables the development of Robotics as a Service (RaaS) market, where software solutions for real-time process control can be offered as a service. For instance, in a welding application, AI-driven camera systems could monitor and adjust heat distribution. The key objectives for using F5G-A are to enable high-bandwidth, low-latency transfer of sensor data to the cloud for real-time analysis, decision-making, and to facilitate low-latency control of robots from the cloud, enhancing their coordination and performance in various application scenarios. See Use Case # 14 in ETSI GR F5G 020 [i.1] for more details.

4.15.2 Technology Requirements and Gap Analyses

4.15.2.1 General

The goal of this clause is to provide a clear understanding of what is needed in terms of technological advancements to meet the high demands of modern robotic systems, including the need for low latency in control and communication, as well as the durability and flexibility of physical components like cables.

4.15.2.2 Latency

Latency is a critical factor in the performance of robotic systems, which directly impacts robotic systems efficiency and safety. Safety is largely meant in terms of human safety, and robots need to stop quick enough to not injure somebody. The need to minimize latency in robotic control and safety mechanisms is paramount to ensuring precise and reliable operation. For milling applications, there is the need to follow an accurate predefined toolpath and compensation for process-induced disturbances, which is driving the need for a latency no greater than 1 ms.

Service: Acceptable Milling latency < 1 ms.

Ideal Milling latency = 0,25 ms.

[R14-1] The F5G-A network used in robotic system shall support latency of less than 1 ms for the acceptable milling application.

[R14-2] The F5G-A network used in robotic system shall support latency of 0,25 ms for the ideal milling application.

To allow for the immediate detection of humans and the execution of emergency stop commands a maximum latency of 5 ms needs to be supported.

[R14-3] The F5G-A network used in robotic system shall guarantee a maximum latency of 5 ms for an acceptable safety application.

[R14-4] The F5G-A network used in robotic system shall have a latency of 0,5 ms for the ideal safety application.

The discrepancy between ideal and achievable latencies presents a gap in current technology's ability to meet optimal performance standards. The ideal latency for milling applications is 0,25 ms however 1 ms is what is achievable.

[Gap14-1] None.

[Gap14-2] The latency for the ideal milling application is currently not achievable.

For safety application the ideal latency is 0,5 ms for the execution of emergency commands, however 5 ms is what is achievable.

[Gap14-3] None.

[Gap14-4] The ideal latency for safety application is 0,5 ms is currently not achievable.

4.15.2.3 Cable Requirements

The functionality of Robotics as a Service (RaaS) is not only dependent on the robotic system but also on the quality and performance of the cables, which are cables containing fibres that are used. These cables need to withstand the physical demands of movement alongside the robot, which includes extensive bending and twisting during the movement of the robot. To maintain integrity and functionality during operations the cable bend shall be 10 times the outer diameter of the cable.

[R14-5] Cables utilized in RaaS shall be capable of withstanding a minimum of $\pm 90^\circ$ twist per meter for acceptable cable twisting.

[R14-6] The cable bend shall be 10 times the outer diameter of the cable for acceptable cable bending.

[R14-7] Cables utilized in RaaS shall be capable of withstanding a minimum of $\pm 180^\circ$ twist per meter for ideal twisting.

[R14-8] The cable bend shall be 12,5 times the outer diameter of the cable for ideal bending.

The ideal performance of cables goes beyond the minimum requirements, which would ensure longer life and greater reliability.

[Gap14-5] None.

[Gap14-6] None.

[Gap14-7] The ideal cable requirements of $\pm 180^\circ$ twist per meter which is currently not supported.

[Gap14-8] The ideal bend is 12,5 times the outer diameters not currently supported.

4.15.2.4 Ease of Installation

The success of Robotics as a Service (RaaS) also hinges on the seamless integration of network communication technologies, including the adoption of F5G Advanced networks. For RaaS systems to be truly accessible and efficient, the installation process for these advanced network technologies is straightforward, for robotics experts, who may not have prior knowledge of networking nor for F5G-A specifics. This requirement aims to minimize the barrier to entry for adopting advanced networking capabilities in robotic systems, ensuring that expertise in robotics is sufficient to leverage the benefits of F5G-A.

- [R14-9] The F5G-A network communication system shall be designed to allow a robotics expert to complete the installation and configuration without prior knowledge of F5G-A technology.

Despite the need for simplicity in installation, there exists a discrepancy between the current installation complexity and the ideal scenario where F5G-A can be deployed by robotics professionals effortlessly.

- [Gap14-9] Simplified installation and configuration of enterprise network communication for RaaS applications effectively is currently not supported and still need for specialized knowledge or training in F5G-A technology.

Overcoming this gap requires simplifying the installation process, enhanced documentation, or providing intuitive installation tools that guide users through the process without the necessity for deep technical knowledge of F5G-A.

4.15.2.5 Integration of F5G-A networks with ROS and DDS

The Robotics Operating System (<https://www.ros.org/>) is used for a variety of robot control and management tasks. It uses a particular communication sub-system called Data Distribution Service (DDS) [i.30]. The use of DDS is not mandatory, but a large number of implementations are using it. The DDS specification [i.30] describes a data-centric publish-subscribe model for distributed application communication and integration. ROS can use other communication middleware than DDS.

- [R14-10] The F5G-A network communication system should support the Data Distribution Service (DDS), when the Robotics Operating System (ROS) is using the DDS communication service.

The DDS is supporting a variety of QoS Policies (see section 2.2.3 in [i.30] for a set of supported policies). Some of them need the underlying F5G-A network's QoS support.

- [Gap14-10] The mapping of the DDS over the F5G-A network architecture is currently not standardized.

4.15.3 Current related standard specifications

4.15.3.1 Cable Specifications

The current cable standards for robotics, particularly those pertaining to Robotics as a Service (RaaS), are driven by industry benchmarks set by leading manufacturers such as Igus®. These standards ensure that cables are robust enough to handle the dynamic requirements of robotic movement, accounting for both flexibility and durability.

Igus® is a cable manufacturing company and is recognized for setting a high standard in the field of robotic cables. Their specifications are designed to ensure that cables can endure the stresses of continuous movement, including bending and twisting, which are common in robotic applications. These specifications are often used as a benchmark for durability and flexibility in robotic cable design.

4.15.3.2 Data Distribution Service (DDS)

As described by [i.30], "The DDS specification describes a Data-Centric Publish-Subscribe (DCPS) model for distributed application communication and integration". This specification defines both the Application Interfaces (APIs) and the Communication Semantics (behaviour and quality of service) that enable the efficient delivery of information from information producers to matching consumers. The purpose of the DDS specification can be summarized as enabling "the Efficient and Robust Delivery of the Right Information to the Right Place at the Right Time".

The mapping of DDS constructs to underlying network technologies of any sort is not specified, but certain QoS Policy objects require the support of the underlying network technology:

- Section 2.2.3.8 in [i.30] LATENCY_BUDGET: indicates to the middleware the "urgency" of the data-communication.
- Section 2.2.3.11 in [i.30] LIVELINESS: the service to ensure that particular entities on the network are still "alive".
- Section 2.2.3.14 in [i.30] RELIABILITY: allows for reliable communication.
- Section 2.2.3.15 in [i.30] TRANSPORT_PRIORITY: to allow the application to take advantage of transports that are capable of sending messages with different priorities.

4.16 All-optical base for urban rail transit communication network

4.16.1 Use Case Briefing

As the important infrastructure and popular city transport, the urban rail transit system plays an important role in the urban economic and social development. The urban rail transit system includes an urban rail transit communication system, a signalling system, an Automatic Fare Collection (AFC) system, and a monitoring system. The urban rail transit communication system supports the railway operation and management system, and is an essential integrated system to ensure safe, fast and efficient train operation. The urban rail transit communication system includes three subsystems, a dedicated communication subsystem, a police communication subsystem, and a civil communication subsystem. This use case focuses on the dedicated communication subsystem. The dedicated communication subsystem primarily includes: the wireline transmission system, the wireless transmission system, the order wire telephone system, a dedicated telephone system, a video surveillance system, a Passenger Information System (PIS), a broadcast system, a clock synchronization system with support for Network Time Protocol (NTP) providing the unified standard time information, and other subsystems.

The rapid digitalization of the urban rail transit system, requires a dedicated communications subsystem to support the emerging all-digital services, interactive intelligent services, and ultimate user experience. The operation of the urban rail transit system needs to optimize and utilize more digital technology, which results in the requirement to have better and higher performant networks. This means the dedicated communications subsystem requires much more bandwidth, higher reliability, and improved Quality of Service.

With the development of optical communication technologies, the urban rail transit communication system for urban rail transit has evolved over several generations, including PCM/PDH (up to 155 Mbps), SDH (2,5 Gbps and 10 Gbps), and Multi-Service Transport Platform (MSTP with up to 40 Gbps). Currently the dedicated communication subsystem is based on Multi-Service OTN (MSOTN) with 100 Gbps, which supports the intelligent and cloud-based urban rail transit systems. See Use Case # 15 in ETSI GR F5G 020 [i.1] for more details.

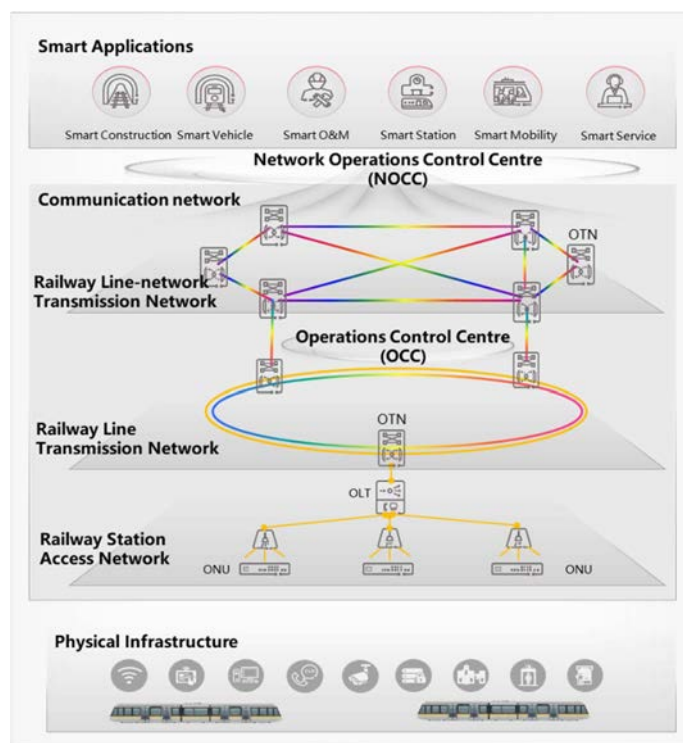

**Figure 11: Overview of urban rail transit communication system
(Source: ETSI GR F5G 020 [i.1])**

4.16.2 Technology Requirements and Gap Analyses

4.16.2.1 General

The urban rail transit network is evolving and is being driven by service cloudification, service intelligence and OAM agility:

- 1) Service cloudification:
 - The urban rail transit cloud includes cloud computing applications and artificial intelligence in the urban rail transit industry is moving the data storage and the data processing to the cloud. As a result, the dedicated communication subsystem between the urban rail transit system and the cloud needs higher bandwidth, higher reliability, and lower latency connectivity than the legacy communication network.
- 2) Service intelligence:
 - The current smart services are multi-dimensional and multi-level intelligent systems including smart applications, such as passenger services, railway power system, railway infrastructure, railway operation security, railway network management, and train schedules. The different intelligent systems and applications require a diversified access approach, differentiated transport network, with secure traffic flow isolation, and high reliability.
- 3) OAM agility:
 - With the rapid development of the urban rail transit network, the operation and management mode are changing from single-railway line independent operation to multi-railway line comprehensive operation. The layout of the urban rail transit network in the metropolitan area needs a unified network for operation and management. This will create an effective inter-connection between the urban rail transit in central cities and neighbouring cities (towns). To further ensure efficient, secure, fast, and smooth operation and management, it is necessary to build a single network to bridge the information silos of each railway line system.

- The urban rail transit network is evolving to an all-optical network base communication network requiring high security, low latency, flexible scalability, and simplified OAM. With an intelligent network management and control platform that integrates management, control, analysis, and AI, the all-optical network base communication network for the urban rail transit network will be more agile, intelligent, and secure.

Key capabilities for an all-optical network base communication network for the urban rail transit network are as following:

- **Security and reliability:** The different intelligent systems and applications require a diversified access approach, differentiated transport network, which is used to carry different types of services with high secure traffic flow isolation, and high reliability.
- **Flexible scalability:** Cloudification of the urban rail transit network mean cloud computing applications and artificial intelligence is moving the data storage and the data processing to the cloud. This requires greater bandwidth than currently deployed. So, network equipment with up to 800 Gbps bandwidth per wavelength will be required to support this cloudification evolution.
- **Simplified deployment:** The railway station's all-optical access network with additional services and increased number of connected stations results in larger volume of traffic. The capacity in the station needs to be expanded from the current XGS-PON to 50 G PON reusing the current fibre infrastructure.
- **Deterministic and low latency:** the move to the cloud will necessitate low and deterministic latency for the new smart applications. Services connect to the cloud utilizing a wavelength-level one hop mechanism, eliminating the need for electrical-layer forwarding on intermediate nodes and reduces latency.

4.16.2.2 All-optical network base communication network for urban rail transit network

Based on the discussion above the all-optical network base communication network for the urban rail transit network needs to support the following functions and capabilities:

The railway line-network transmission network using 200 G/400 G OTN and ROADM/OXC technologies with flexible wavelength grooming, needs to support the smooth evolution to 400 G/800 G or above to support cloudification.

- [R15-1] The railway line-network transmission network for the urban rail transit network shall support the smooth evolution to 800 Gbps per wavelength.

The railway line-network transmission network for the urban rail transit network interconnection bandwidth is mainly 100 Gbps or 200 Gbps per wavelength, with a limited number of 400 Gbps. 800 Gbps interfaces for DCI/Metro applications supporting the networking and transmission of high-rate clients (e.g. 100 GE, 200 GE, 400 GE, 800 GE) is specified in other SDOs, such as ITU-T SG15, IEEE and OIF. These specifications can meet the demands of the railway line-network transmission network evolution. In this case standardization is ahead of the needs of the railway line-network transmission network.

- [Gap15-1] None.

Grey light is widely deployed for the railway line transmission network. For this network to evolve it needs to support a modular configuration of grey light and coloured light to satisfy the reuse of the current grey light resources and the on-demand expansion based on coloured light with one-hop wavelength connection per station.

- [R15-2] The railway line transmission network for the urban rail transit network shall support a modular configuration of both grey light and coloured light.

The current technology can support coexistence of grey light and coloured light and there is no need for standardization.

- NOTE: Grey light indicates an optical interface with a single wavelength. Coloured light indicates an optical interface with the option of multiple standard wavelengths, which can be optically multiplexed into one fibre.

- [Gap15-2] None.

The railway station access network currently supports PON technology (XGS-PON). The all-optical railway station access network with additional services and increased number of connected stations results in greater number of traffic flows. The capacity in the railway station needs to increase from the current XGS-PON to 50 G PON without deploying new fibre.

- [R15-3] The railway station access network for the urban rail transit network shall support up to 50 Gbps and co-existence with multiple PON generations.

GPON or 10 G PON is mainly deployed in the railway station access network for the urban rail transit network. 50 G PON has been specified in ITU-T SG15 Q2 [33]. It meets the smooth evolution demands as it supports the coexistence with earlier PON generations.

- [Gap15-3] None.

Hard isolation should be used to provide a highly secure, reliable, and scalable transport network for smart services and cloud services, which need to be isolated from each other, which typically come with a TDM based technology. Minimizing bandwidth wastage is important so efficient allocation of service flow bandwidth to transport technology is essential.

- [R15-4] The F5G Advanced network of the urban rail transit network shall support hard isolation.
- [R15-5] The F5G Advanced network of the urban rail transit network shall support efficient bandwidth utilization.
- [R15-6] The F5G Advanced network of the urban rail transit network shall support low latency, low latency variation, efficient Operation, Administration and Maintenance (OAM).

Fine grain OTN (fgOTN) technology has been specified in ITU-T SG15. With the standardization of fgOTN, this technology can migrate the urban rail transit network from SDH/MSTP to fgOTN. The fgOTN provides fine granular bandwidth, low latency, low latency variation, and efficient transport of a large number of high-quality sub 1 G services.

- [Gap15-4] None.
- [Gap15-5] None.
- [Gap15-6] None.

Because services and processing of the urban rail transit system has moved from a local individual railway stations to a cloud-based processing system, the reliability of the network connection is more important for the efficient management and control to support the urban rail transit system.

- [R15-7] The F5G Advanced network of the urban rail transit network shall support 99,9999 % reliability.

OTN and fgOTN satisfies the reliability requirement.

- [Gap15-7] None.

4.16.3 Current related standard specifications

4.16.3.1 ITU-T

In the past 30 years, ITU-T has driven the standardization of OTN, with the line rate of OTN increasing from 1,25 Gbps to 400 Gbps and beyond. Currently, OTN technology is evolving to the next generation in two directions. The first direction is beyond 400 G OTN technology to support 800 GE clients mapping and up to 800 Gbps flexible OTN interface. The second direction is fine-grain OTN with 10 Mbps bandwidth granularity to efficiently support a large number of high-quality sub1 G services and the migration of legacy SDH/MSTP networks, increasing the value of OTN to meet the future communication demands.

Recommendations ITU-T G.709.x [12] to [15] B400G OTN/FlexO has been approved by ITU-T SG15 on 08 March 2024.

4.16.3.2 IEEE

IEEE P802.3df [32] 400 Gbps and 800 Gbps Ethernet has been completed with the approval of IEEE 802.3df [32] by the IEEE-SA Standards Boards on 16 February 2024.

4.17 Optical Fibre sensing for telecom operators

4.17.1 Use Case Briefing

Optical fibre communication is essential to modern society, fibre cables are deployed worldwide to carry communication signal, even in some remote places which are uninhabited. Therefore, the telecom operators need to perform measurement to monitor their fibre cable plant, ideally in real time, to prevent the fibre cables from being damaged or to quickly locate the damaged fibre cables if damage has occurred. Manual patrols are used which is very inefficient and none real-time, especially in remote uninhabited locations, e.g. in large and unmanned desert areas. Therefore, fibre sensing techniques are necessary. See Use Case # 16 in ETSI GR F5G 020 [i.1] for more details.

Fibre sensing has several advantages:

- High positioning precision.
- Easy deployment.
- Easy maintenance.
- High reliability.
- Very secure.

In the F5G-A Use Case # 16 in ETSI GR F5G 020 [i.1] on optical fibre sensing for telecom operators, there are scenarios for real-time fibre plant monitoring by means of fibre sensing and the requirement needs are outlined.

4.17.2 Technology Requirements and Gap Analyses

4.17.2.1 General

Fibre sensing for telecom operators needs to support the following functions and performance:

- | | |
|-----------|--|
| [R16-1] | The vibration waveform detection distance shall be greater than 80 km per fibre sensing node device. |
| [Gap16-1] | Standards enabling vibration waveform detection distance greater than 80 km are currently not available. |

It is important to minimize the false negative and false positive rate. The rate should not exceed 1 % in order to achieve an effective signal collection rate of 99 %.

- | | |
|-----------|--|
| [R16-2] | False negative and false positive rate shall not exceed 1 %. |
| [Gap16-2] | Standards which support $\leq 1\%$ false negative and false positive rate are currently not available. |
| [R16-3] | The vibration waveform detection accuracy shall be at least 95 %. |
| [Gap16-3] | Standards supporting vibration waveform detection with an accuracy of at least 95 % are currently not available. |
| [R16-4] | The detected event location accuracy shall be ≤ 10 m. |
| [Gap16-4] | Standards supporting event location accuracy of ≤ 10 m are currently not available. |

The sensing system shall be capable of quickly learning from the local measured samples in order to improve the accuracy and efficiency of fibre fault detection in the future.

- | | |
|-----------|--|
| [R16-5] | The fibre sensing system shall support fast learning of fibre fault detection and self-improving. |
| [Gap16-5] | Standards for fibre sensing system which support fast learning and self-improving are currently not available. |

The need for the fibre sensing system to support real time monitoring is important.

[R16-6] The fibre sensing system shall support continuous real time monitoring.

[Gap16-6] Standards which support a real-time monitoring capability are currently not available.

The network management system shall manage the fibre sensing system and Geographic Information System (GIS) shall be an integral part of the management system.

[R16-7] The Telecom operator network management system in cooperation with GIS shall be capable to link the detected events to geographic locations.

GIS system is widely used in similar system.

[Gap16-7] None

To manage the fibre sensing system cost and achieve easy deployment, it is important that the fibre sensing system reuses the communication system hardware or at a minimum uses the same components as the communication system. Standards which define the optical interface, the electronic interface and the management & control interface shall be developed.

[R16-8] The fibre sensing system definition of the optical interface, the electronic interface and the management & control interface should be standardized.

[Gap16-8] Standards which define the fibre sensing system architecture, the optical interface, the electronic interface and the management & control, and enabling communication hardware reuse or supply chain reuse, are currently not available.

4.17.3 Current related standard specifications

4.17.3.1 ITU-T

In the ITU-T SG15 plenary meeting in November 2023, a standard project in Recommendation ITU-T G.681 [i.16] was created in Q6 to define the optical layer interface requirements for the Distributed Fibre Optic Sensing system (DFOS). DFOS will define the optical detected distance, crosstalk with the communication system, and sensitivity. The Recommendation ITU-T G.681 [i.16] scope is illustrated in Figure 12.

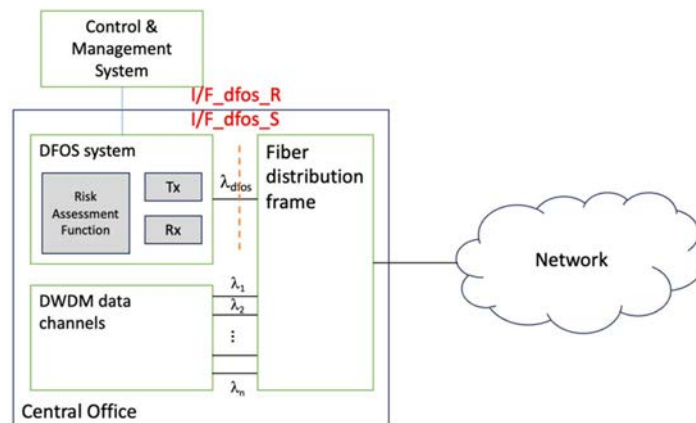

Figure 12: ITU-T G.dfos scope

In ITU-T SG15 Q2, the project G.vhsp (Very High Speed PON) [i.28], which focuses on technologies for beyond 50 G PON), includes the study of fibre sensing based on the PON ODN, which is aiming to perform fibre sensing over short reach (normally within 20 km).

4.18 QoD App-Flow service provisioning

4.18.1 Use Case Briefing

As the residential broadband market develops, there are more and more real-time residential broadband services which improve the home entertainment experience, in addition to IPTV and VoIP, including home health services, work from home, education, security services, and utility services. For the SME scenarios, the advanced broadband services include cloud desktop, VR teleconferencing, security services, surveillance and a larger number of devices among others.

In today's Access Network, the real-time services as mentioned above are transported together with non-real-time Internet services through FTTR, ONU, and OLT. Therefore, those real-time services cannot be guaranteed and the QoE of those real-time services does not satisfy the expectation.

One solution is to abstract the network by service APIs. These service APIs will help the network operators to provide the Network as a Service (NaaS) capabilities with differentiated SLAs, enabling a new business models for network operators.

The Quality on Demand (QoD) API is a key service API, which allows an application to request an improved connection (e.g. guaranteed bandwidth and latency) for a given application flow (App-Flow) from the application client to the F5G-A network server. The QoD API applies in both the Access Network and the Customer Premises Network (CPN), to enable application flow level control for fixed network broadband services. See Use Case # 17 in ETSI GR F5G 020 [i.1] for more details.

4.18.2 Technology Requirements and Gap Analyses

4.18.2.1 General

The F5G-A network shall support a Quality on Demand Application Programming Interface (QoD API) for the application to request a particular QoS for an Application Flow (App-Flow) on-demand. The request can come from the application user, the application provider, or the application itself.

[R17-1] The F5G-A network shall support Quality on Demand APIs.

[Gap17-1] QoD API standards for fixed networks is currently unavailable.

The management and operation support system shall be capable of provisioning service packages, which are a set of communication services bundled together with different QoS requirements and different QoE needs. The individual provisioning of QoS for each App-flow and the total set of communication services is required.

[R17-2] The F5G-A network shall support the provisioning of different App-Flow services with different QoS requirements.

[Gap17-2] A standard for the provisioning of App-Flow services with different QoS requirements is currently unavailable.

Since QoD APIs provide guaranteed SLAs, SLA management needs to be supported including the provisioning of the SLA, the monitoring of the SLA, and the termination of the SLA.

[R17-3] The F5G-A network shall support SLA management.

SLA management does exist for enterprise services but not for residential and SME services. Typically, SLA management is focused on larger granularity services, not on per user or per application flow granularity bases.

[Gap17-3] SLA management for fine granular application flows is currently unavailable.

For the fine granular management of application flows, the Customer Premises network and the Access Network need to support QoS management mechanisms on a per application flow granularity in the data plane. Also, the data plane needs to continuously react in real-time to maintain the QoS for the application flows.

[R17-4] The F5G-A network shall support application flow granularity QoS management mechanisms in both the CPN and the Access Network.

Coarse granular QoS management is usually supported, but there is no standard for fine granular application flow QoS management mechanisms with very low reaction time.

[Gap17-4] The standard for fine granular application flow QoS management mechanisms with very low reaction time is currently unavailable.

[R17-5] The F5G-A network shall support a real-time QoS control subsystem in both the CPN and in the Access Network.

Non-real time QoS control is usually performed in the network management system.

[Gap17-5] The real-time QoS control and adaptation to application changes is not currently available.

Application flows need to be detected (automatically or through an API interaction between applications and the network) and then mapped to QoS guaranteed connections in the data plane.

[R17-6] The F5G-A network shall support the identification of fine granular application flows through the QoS API.

[R17-7] The F5G-A network shall support the identification of application flows automatically.

[R17-8] The F5G-A network shall support the mapping of fine granular application flows to the underlying QoS guaranteed connections.

For the identification of application flows through an API interaction, similar standards in CAMARA exist, however they are adapted to the needs of mobile applications.

[Gap17-6] For the identification of fine granular application flows through the QoS API through API interaction, is currently not available.

[Gap17-7] The standard for the automatic identification of application flows, is currently not available.

[Gap17-8] The mapping of fine granular application flows to the QoS guaranteed connections is currently not available.

Telemetry is needed to be scaled up to monitor the large number of application flows in the data plane, therefore scaled up mechanisms for telemetry are needed.

[R17-9] The F5G-A network shall support telemetry for a very large number of application flows.

[Gap17-9] Standards for telemetry on a large scale are currently not available.

The interaction between the Access Network and the CPN in terms of compute functionality achieves optimized network performance.

[R17-10] The F5G-A network shall support ONUs with computing-enhanced ONU/FTTR functionality.

[Gap17-10] Standards for support of ONUs with compute functionality are currently not available.

The F5G-A compute functionality located in the CPN and the Access Network can be used for various tasks. Specifically, optimizing the overall network performance needs cooperation between the compute tasks running in the CPN (close to the end user devices) and compute task running at the Access Node (additional compute power and information about all connected CPNs). Depending on the task the cooperation between distributed compute tasks is needed for the most optimal outcome.

[R17-11] The F5G-A network shall support cooperation of compute functionality located in the access and the customer premises network equipment.

[Gap17-11] Standards for cooperation of compute located on different Access Network and CPN equipment is currently not available.

4.18.3 Current related standard specifications

4.18.3.1 CAMARA

The CAMARA project (The Linux® Foundation Projects - <https://camaraproject.org/>) by the telco global API alliance and an open source project within the Linux® Foundation are defining a set of APIs with a focus on mobile networks and services. Whether the same or similar APIs are suitable for F5G-A networks will need to be determined.

NOTE: Linux® is the registered trademark of Linus Torvalds in the U.S. and other countries.

4.18.3.2 ITU-T QoS in PON and G.fin

ITU-T Q2 and Q3 define the Passive Optical Access Network (PON) [34] and Fibre on Premises Networks (G.fin) [7], both technologies have some coarse granular mechanisms for QoS management, usually per class of service granularity.

4.18.3.3 ETSI ISG F5G Telemetry

ETSI ISG F5G has defined the access network telemetry data models. The mechanisms and performance as defined in ETSI GS F5F 011 [i.31] are flexible and different telemetry tasks can be performed on-demand. However, due to limitations in the data plane elements, the number of flows which telemetry can be applied to is limited.

5 F5G-A Technology requirements and landscape for Release 4 use cases

5.1 Overview

5.1.1 Introduction

This clause is reliant on the use cases as defined in ETSI GR F5G 032 [i.35] and specifies per use case the technology requirements, describes the gaps in technology to implement those use cases and the current available related standards.

NOTE: Some clauses define requirements, standards, and gaps for several similar use cases together.

The following use cases are included in the present document, refer to ETSI GR F5G 032 [i.35] for a detailed description of the use cases.

The following use cases refer to use cases of F5G-A release 4, for the requirements and gap analyses of F5G-A release 3 use cases see clause 4 of the present document. In the following list, only use case titles are given for reference:

- UC#18: Smart Hospital
- UC#19: Energy-efficiency by deactivating low-load ports
- UC#20: Cloud-based Object Wave Transmissions
- UC#21: P2MP fgOTN for premium private lines
- UC#22: Smart Sensor Cloud for AI in Industrial Manufacturing
- UC#23: Integrated NAS over FTTR
- UC#24: Generating an Energy Map for sustainable F5G-Advanced networks
- UC#25: Flat wheel detection using Distributed Acoustic Sensing (DAS)
- UC#26: Integrated RFID over FTTR

- UC#27: AI-Powered Intelligent Flash Disconnection Fault
- UC#28: 3D video enabling via FTTR
- UC#29: Optical cable Co-route detection based on DFOS technology combined with AI capability
- UC#30: Generative AI for F5G-A Network Management Tasks
- UC#31: Distributed Intelligence with Privacy-Preserving Features for FTTR

5.1.2 Document structure overview

The remainder of clause 5 covers the use cases of F5G-A release 4 itemized in clause 5.1.1. The structure of each use case is:

- Brief use case overview.
- Technology related to the use cases and associated requirements.
- Gaps in standards to meet the requirements.
- Current standards relevant to the use case.

The order of the use cases matches that of those defined in ETSI GR F5G 032 [i.35] and the requirements are structured as [RUC#-xx] where UC# is the use case number defined in ETSI GR F5G 032 [i.35] and xx is the sequence number of the requirements. The gaps have a similar structure [GapUC#-yy] and again UC# is the use case number defined in ETSI GR F5G 032 [i.35] and yy is the sequence number of the gaps. Ideally there should be a one to one correspondence between the requirements and the gaps, however it is possible that a given requirement may have multiple gaps and this will be accommodated in the present document. If the requirements are already satisfied by current standards then the gap is labelled 'None' to indicate there is no gap.

NOTE: There is an offset of one between the use case number and the clause number in the present document due to the inclusion of a clause on the present document overview in clause 5.1.

5.2 Smart Hospital

5.2.1 Use Case Briefing

Smart hospitals leveraging F5G-A technology utilize passive optical networks for robust, scalable, and secure connectivity among medical systems, devices, and patient data platforms. This network architecture enables real-time access and interoperability for healthcare applications, powered by AI, IoT, and AR/VR, while maintaining strict cybersecurity and privacy standards. High-capacity optical links support diverse medical devices and demanding services, simplifying deployment and enhancing efficiency, automation, and patient experience in modern healthcare environments.

While this approach takes inspiration from the Fibre-To-The-Room (FTTR) paradigm, the key difference is its broader scope. Instead of serving only a single home, the proposed deployment can extend across multiple buildings, each with distinct requirements and installation options. In this scenario, several PONs are used to segment network traffic and support diverse protection schemes, ensuring higher reliability. By contrast, FTTR typically relies on a single residential gateway per home, with no redundancy, and uses in-house cabling (often with invisible fibres) to connect different rooms.

5.2.2 Technology Requirements and Gap Analyses

5.2.2.1 General

In smart hospitals, Passive Optical Networks (PON) shall meet current standards to ensure reliable, secure, and efficient operation. Key aspects include scalable optical line terminals, standardized fibres and splitters, and fast fault recovery with strong encryption. Network segmentation and loop detection are vital for security and service continuity. Some features, like 50G-PON compatibility and cloud-based management, remain under development.

5.2.2.2 Optical network layer

In smart hospitals, the PON at the optical network layer should follow the most recent and widely accepted standards. This helps ensure that all equipment and components perform reliably and meet the high demands of the healthcare environment.

- [R18-1] OLT should be scalable to support multiple current widely deployed standards like GPON (Recommendation ITU-T G.984.x [i.52]), XGS-PON (Recommendation ITU-T G.9807.x [i.53]), 50G-PON (Recommendation ITU-T G.9804.3 [33]), and coexistence with legacy systems (Recommendation ITU-T G.9805 [i.54]).
- [Gap18-1] Interoperability guidance for 50G-PON deployments is still under active development.
- [R18-2] Optical splitters shall meet IEC 61753-031-2 [47] insertion loss limits. As actual splitter insertion losses can vary by manufacturer and environmental conditions; achieving consistent loss is key to meet the power budget requirements when designing the network.
- [Gap18-2] None.
- [R18-3] Fibre shall comply with Recommendation ITU-T G.657.A1 [49] for indoor and Recommendation ITU-T G.652.D [48] for outdoor with defined attenuation.
- [Gap18-3] None.

5.2.2.3 Network architecture and security

In smart hospitals, PON systems shall focus heavily on reliability and security because of the sensitive nature of their use. These networks support critical applications and handle confidential patient data, so it is essential to ensure continuous service and strong protection to maintain privacy and support important healthcare operations.

- [R18-4] Deployments should support dual homing protection type B/C with switchover less than 1 s.
- [Gap18-4] None.
- [R18-5] OLT and ONU shall support at least AES-128 encryption since the use case envisions to handle private data from patients.
- [Gap18-5] GPON currently only supports encryption for downstream but not for upstream. Therefore, the use of this technology should be carefully analysed. For example, it could be restricted to waiting rooms without security requirements. In case security is needed in a GPON deployment, then the user application would need to provide E2E encryption.

When a ring-shaped network is detected, the involved ONU port shall be automatically disabled to prevent broadcast storms and service degradation. Once the loop condition is resolved, the disabled ONU port shall be automatically re-enabled.

- [R18-6] The PON network should support automatic ring network detection.
- [Gap18-6] Automatic ring network detection and disabling/re-enabling ONU ports to prevent broadcast storms is not currently supported explicitly in current ITU-T PON standards, and these procedures are typically implemented as vendor-specific (optional) features to improve network resilience.

The network shall be able to provide logical separation of intranet, extranet, and intelligent device networks (virtual networks) to prevent interference and enhance security. This entails the support of minimum four virtual network, with a recommendation for eight virtual networks, allowing scalability in service separation.

- [R18-7] The network shall be able to provide logical separation of at least 4 virtual networks.
- [Gap18-7] None.

5.2.2.4 Network management system (NMS)

A Network Management System (NMS) shall provide interfaces for related resource management systems and service support systems based on requirements. The NMS shall support all management functions of the Network Element layer and the network layer. Management functions include security management, topology management, alarm management, fault diagnosis, performance management, log management, and software management of network elements.

The NMS should support a management platform including a GUI and a REST API for the NBI. In the context of PONs, having a centralized web/cloud-based management system with RESTful APIs is increasingly considered best practice, but this aspect is not fully standardized across all PON systems. In fact, this remains largely vendor-defined, with the corresponding eventual lack of interoperability.

[R18-8] The NMS should support a GUI and a RESTful API for the north bound interface.

[Gap18-8] The support of management with common REST API schema or interfaces is currently not supported by PON management standards.

5.2.3 Current related standard specifications

5.2.3.1 ITU-T (International Telecommunication Union)

- Recommendation ITU_T G.984.x [i.52] (GPON): Defines the technical framework for gigabit-capable passive optical networks, including line rates, encryption (AES-128), optical budgets, and redundancy.
- Recommendation ITU_T G.9807.x [i.53] (XGS-PON): Specifies symmetric 10 Gbit/s PON transmission and coexistence with GPON, addressing demands for higher bandwidth and secure, flexible network slicing.
- Recommendation ITU_T G.9804.x [i.55] (50G-PON): Establishes 50 Gbit/s PON standards with scalable rates and splitting ratios, enabling future-proof high-capacity networks that meet anticipated healthcare data traffic growth and redundancy needs. ITU-T G.9804.1 Amendment 3 (2025) show 1+1 (type C) protection schemes with switchover times that can vary from few tens of milliseconds up to about 1 s, trading off ultra-fast recovery for higher availability and more comprehensive redundancy at the ONU level.
- Recommendation ITU_T G.994x [7], [8], [9], [i.11] and [i.12] "high speed fibre-based in-premises transceiver": Specifies the different requirements and recommendation for the equipment needed in a FTTR network.

5.2.3.2 IEC (International Electrotechnical Commission)

- IEC 61753-031-2 [47]: Provides performance requirements and test methods for optical splitters and passive components, ensuring the physical layer components in PON systems meet insertion loss, polarization dependence, and reliability criteria critical for hospital-grade optical network quality.

5.2.3.3 IEEE (Institute of Electrical and Electronics Engineers)

- IEEE 802.1X [i.61]: Defines port-based network access control protocols critical for authenticating hospital users and devices in POL networks, supporting security requirements around device authentication and access management.
- Ethernet Physical Layer Standards (e.g. IEEE 802.3): Set specifications for high-speed Ethernet physical interfaces used by ONUs and switches, ensuring interoperable and reliable data transport interfaces.

5.2.3.4 IETF (Internet Engineering Task Force)

- IETF RFC 6632 [i.56]: Provides guidelines and standards for network management protocols, including SNMP extensions and secure management, underpinning the operational requirements for centralized network monitoring, fault management, and secure NMS operations.

5.3 Energy-efficiency by deactivating low-load ports

5.3.1 Use Case Briefing

In F5G-Advanced networks, energy consumption is a critical concern for the telecommunication industry. As the end-user requirements and the number of connected devices continue to rise, the resulting increase in traffic load places greater burden on the fixed broadband network. The network experiences fluctuating traffic patterns, including peak hours and valley hours, due to various factors such as application types, user behaviour and environmental conditions. Therefore, during the valley hours there are often ports with low load. By identifying these underutilized ports, rerouting traffic to other paths and activating the low-power mode, can minimize the overall energy consumption with minimal or acceptable impact on the network performance. See Use Case # 19 in ETSI GR F5G 032 [i.35] for more details.

5.3.2 Technology Requirements and Gap Analyses

5.3.2.1 General

Achieving energy efficiency in F5G-A networks by rerouting the traffic from underutilized port and activating low-power mode requires the following functional chain:

- A granular and model-driven telemetry to collect all required network traffic and energy metrics from different sources and from all relevant domains.
- A real-time and historical traffic analysis to identify underutilized ports.
- An intent-driven and context-aware decision making to determine when to reroute traffic and initiate port transition.
- To execute traffic rerouting and port status change as a single coordinated operation to maintain service continuously.

Although existing standards and architectural address many of these requirements, several gaps remain to be resolved before an energy efficiency management system can be fully implemented in F5G-A infrastructure.

5.3.2.2 Energy and Load Monitor

The energy and load monitor should provide continuous model-driven telemetry of both energy and load traffic utilization. The requirement below establishes the essential monitoring capabilities that underpin the subsequent automation functions.

- [R19-1] The Energy and Load Monitor shall collect port energy consumption and traffic load every second as mentioned in IETF RFC 9232 [38].

This implies that the devices should expose energy metrics and link utilization metrics via model-driven streaming telemetry to provide up-to-date insights.

- [R19-2] The Energy and Load Monitor shall correlate measured energy with traffic statistics to compute energy-efficiency indicators as defined in ETSI ES 203 475 [39].

EXAMPLE: The energy metrics may be Watts, the link utilization metrics may be bytes, the streaming telemetry may be gNMI, and the energy-efficiency indicator may be joules/bit.

There is currently no widely adopted standard data model to report real-time energy usage per port or device.

- [Gap19-1] No standard YANG model that provides energy-consumption metrics.

These composite energy efficiency indicators are not defined in existing standards.

- [Gap19-2] No standard YANG model that provides enough information to calculate energy-efficiency metrics exist.

5.3.2.3 Traffic Analyser

The Traffic Analyser module should ingest live streams and historical data, should apply threshold policy logic or AI/ML prediction and recommends ports whose low utilization is expected to persist.

[R19-3] The Traffic Analyser module shall analyse incoming telemetry in real-time to identify ports with persistently low utilization.

This implies the Traffic Analyser module should process streaming data and detect when a port utilization falls below the defined threshold for a substantial amount of time. This analysis should be granular (per-port or per-flow) to precisely capture underutilized ports.

[R19-4] The Traffic Analyser module shall predict the future load on each port.

This means AI/ML models should forecast whether a current low load will persist, or the demand will increase soon. The proactive energy optimization techniques should be applied by identifying the low-traffic pattern (valley hours).

[Gap19-3] None.

There is no standardized API or YANG model for the analyser to notify the controller that "port X is a low-utilization candidate for power saving." The decision feedback from analytics to control lacks a common language, hindering automation.

[Gap19-4] No standard way of communicating analyser decision to controller.

5.3.2.4 Decision Engine

The Decision Engine converts policy-driven automation operator's intent (e.g. select path with minimum energy consumption) into deterministic actions.

[R19-5] The Decision Engine shall support intent or policy-driven logic to decide if and when to activate or deactivate low-power port mode.

This requires the Decision Engine to correctly interpret the high-level policies and rules so that its decision aligns with the operator's intent.

[R19-6] The Decision Engine shall support the interpretation of redundancy and operator constraints.

Decisions should consider network topology and policy, ensuring that any port reserved as backup is not get selected. This implies consulting topology and inventory data storage to eliminate port that are not eligible, i.e. standby ports shall always remain active.

[R19-7] The Decision Engine shall get guard timing from intent to avoid rapid fluctuations.

This should place the port in a specific state for certain period to keep the network stable and to prevent port flapping. This should include the cost of transition from one state to another.

The guard timing may be defined based on the network polices and business logic.

[Gap19-5] No intent-specific standards to translate operator request into energy-saving actions.

There are intent conceptual standards, but they are generic and doesn't fulfil the requirements of energy-efficient objectives.

[Gap19-6] None.

[Gap19-7] None.

5.3.2.5 Execution Engine

The Execution Engine should orchestrate traffic rerouting, activating low-power mode as a single atomic transaction.

[R19-8] The Execution Engine shall reroute the traffic to available alternative path with no impact on active flows.

[R19-9] The Execution Engine shall be capable of transiting the port into (and out of) low-power mode.

[Gap19-8] None.

Currently, not all hardware equipment supports low-port port mode that places the port in low-power mode and keeps the link signalling active. Most of the current implementation is vendor specific.

[Gap19-9] No standard YANG model attribute to indicate port power saving status.

Currently, there is no standard configuration or state leaf in YANG model to indicate if the port is eligible for power saving, or it is reserved for redundancy. However, there is an effort to define energy management policies, but it is not stable yet.

5.3.2.6 Port Manager

The Port Manager applies configuration changes on individual devices and confirms the successful execution of transactions.

[R19-10] The Port Manager shall support access via RESTCONF or NETCONF using standard model with rollback on error.

This implies that the Port Manager should communicate all port changes to the Decision Engine.

[Gap19-10] None.

The OpenConfig models may be used as standard model.

5.3.2.7 Path Availability

The Path Availability function should maintain multi-layer topology with energy consumption information to compute cross-domain alternative paths before activating low-power port mode.

[R19-11] The path availability shall maintain comprehensive topology and resource data to evaluate alternative paths.

The path availability should have a topology model of the network (nodes, links, link utilization, energy consumption) and Traffic Engineering database that includes link attributes like capacity and energy utilization.

[R19-12] The path availability shall compute alternative paths between the endpoints.

This implies the path availability should run path computation algorithms and validates any high-level policy requirements. It should prioritize the path with minimum energy consumption.

[R19-13] The path availability should support multi-domain coordination.

The implies the path availability should incorporate Path Computation Element (PCE) from all relevant domains (including Packet, OTN, DWDM) to verify end-to-end path availability.

[Gap19-11] No standard metric for energy in routing protocols.

Currently, there is no standard way of incorporating energy cost as a factor in traffic engineering or routing.

[Gap19-12] No energy-aware protocol extension.

There is no standard way to incorporating energy information in paths to make them energy aware.

[Gap19-13] No unified multi-domain path availability interface focused on energy-efficiency.

While there are frameworks for multi-domain computations (including IETF ACTN and ONF TAPI) but they are not adopted to energy optimization yet. This means that orchestrating an end-to-end path setup that accounts for energy considerations across domains currently requires custom integration.

5.3.2.8 Traffic Rerouting

Once the alternative path is validated, the Traffic Rerouting module should migrate all the traffic seamlessly. It should also reverse the process when the port restores to active state.

[R19-14] The Traffic Rerouting module shall identify all active flows on the selected port and dynamically reroute traffic onto the pre-computed alternative path without breaching SLAs.

This implies implementing make-before-break techniques: to move traffic to new path before removing the old one. The rerouting should be transparent to the end users.

EXAMPLE: The techniques to reroute traffic may be Segment Routing (SR).

[R19-15] The Traffic Rerouting module shall support restoring traffic back to original path once the port returns to an active state.

[Gap19-14] None.

[Gap19-15] None.

5.3.2.9 Device Capabilities

The underlying hardware should support low-power port mode and should be configurable via standard protocols and models. It should support fast recovery to restore ports into active states.

[R19-16] The low power port mode shall keep the link signalling alive.

[Gap19-16] No standard model available to define low-power port mode.

5.3.3 Current related standard specifications

5.3.3.1 IETF

- IETF RFC 9232 [38] provides an architecture for streaming telemetry in networks. It encompasses subscription-based data collection (e.g. IETF RFC 8641 [i.57] YANG-Push) to facilitate real-time monitoring as published in 2022.
- IETF RFC 8343 [35] standard model for basic interface statistics and configuration as published in 2018.
- IETF RFC 8660 [i.40] enables controllers to specify explicit paths for flows by encoding path information in the packet labels as 2019.
- IETF RFC 8663 [i.41] allows segment routing instructions to be carried over an IP encapsulation as published 2019.
- IETF RFC 9315 [i.42] defines the intent concepts as published in 2022.
- IETF RFC 8639 [37] defines a YANG data model as published in 2019.
- IETF RFC 8345 [36] defines an abstract (generic, or base) YANG data model for network/service topologies and inventories as published in 2019.
- IETF RFC 8281 [i.43] provides mechanisms for Path Computation Elements (PCEs) to perform path computations in response to Path Computation Client (PCC) requests as published in 2017.
- ETSI ES 203 475 [39] specifies terminology, principles and concepts for Energy efficiency and energy management.

IETF is now developing a set of YANG data models to integrate energy efficiency metrics:

- IETF draft-neumann-green-streaming-yang [i.36] which defines a YANG model to represent device energy measurements. It supports instantaneous power readings and correlated metrics for energy efficiency.

- IETF draft-stephan-green-ucs-and-reqs [i.37] which defines collecting and updating requirements for the management of energy-efficient networks and defining use cases for managing energy-efficient networks.
- IETF draft-ietf-ccamp-otn-tunnel-model [i.7] which describes the YANG data model for tunnels in OTN TE networks.
- IETF draft-cwbgp-green-common-energy-management [i.38] which defines a common YANG module that is meant to be reused by various energy efficiency-related modules such as energy saving network models, energy saving network inventory model and energy saving device models.
- IETF RFC 9845 [i.39] defines a set of opportunities, along with associated research challenges, for networking technology in general and management technology in particular to become "greener".

5.3.3.2 OpenConfig

- OpenConfig-telemetry v0.5 [i.44] defines data model which creates the configuration for the telemetry systems and functions on the device.

5.4 Cloud-based Object Wave Transmissions

5.4.1 Use Case Briefing

The use case is described in more detail in clause 6.3 (F5G-A Use case #20) in [i.35].

Looking beyond Cloud VR (see Use Cases in F5G Use Cases Release 2 [i.46]), it is expected that intuitive and safe stereoscopic experiences through holographic communication will get available. The communication and rendering of 3D models is dependent on many aspects including the capabilities of the end user devices to display the content stereoscopically. See [i.35] for a more detailed description. This use case can be seen as an evolution of Cloud VR oriented use cases due to rendering not necessarily possible to do on the end user device due to battery or performance constrains. Holographic communication is expected to realize remote communication equivalent to real 3D spaces.

5.4.2 Technology Requirements and Gap Analyses

5.4.2.1 General

Object Wave Transmission (OWT) has two aspects to consider. First the communication network needs for transporting holographic content displayed at one point stereoscopically. Second, the storage and processing power needed for rendering 3D content to the devices of choice. In general, the requirements are dependent on the size, resolution and quality of the end user device and the content available.

5.4.2.2 Computing and Storage Requirements

The Cloud-based Object Wave Transmission is rendering the 3D content on compute functionality located on F5G-A equipment somewhere in the F5G-A network architecture [40]. Therefore, requirement with regards to the required compute and storage capability are listed below.

A particular frame shall be rendered in the order of 30 millisecond for 30 frames per second real-time streaming to the end user device. For higher frame rates the rendering time per frame is lower. The study in Recommendation ITU-T J.1318 [i.45] assumes a 3D model complexity of 10k polygons and 30 frames per second. This results in the following requirement, which are based on theoretical calculations not including any optimizations in the implementations or the use of highly optimized algorithms and heuristics.

- [R20-1] For 4K streaming of the content, the compute functionality shall be capable of larger than 16 Peta-FLOPS (Floating-point Operations Per Second) per processing stream.

Since the requirement is dependent on the compute functionalities capacity, there is no standardization gap.

- [Gap20-1] None.

The storage need depends on the implementation. The theoretical calculation of the storage capacity is made based on several assumption from Recommendation ITU-T J.1318 [i.45].

[R20-2] For 4K streaming of the content, the storage capability shall be larger than 400 Megabytes.

Since the storage is a network equipment implementation and resource availability perspective there is no standardization gap.

[Gap20-2] None.

5.4.2.3 Network Requirements

The bandwidth for cloud-based object wave transmission is required to be larger than that for 4K video, to achieve hologram playback with the same experiential quality as 4K video on a Head-Mounted Display (HDM). OWT end user equipment is assumed to play back higher resolution video (hologram) data than traditional TVs. In Cloud VR [11], cloud virtual reality (VR) services are classified into weak interaction and strong interaction, based on interaction characteristics. The network capabilities are always required from an end user device to the location of the network equipment running the OWT rendering functionality.

The suggested per-user bandwidth requirements of cloud-based object wave transmission are based on theoretical calculations and can be optimized depending on the implementation and the specification of the hologram coding.

[R20-3] For 4K streaming of the content, the bandwidth requirement per stream shall be larger than 3Gbit/s.

Though the F5G-A network architecture [40] can provide that bandwidth requirement for a small number of user and streams, for large scale operation more high-speed networking technologies are required from the end user device to the network element/computer element, where the compute functionality is located. With the introduction of optimized coding the bandwidth can be reduced, but it might have an impact on latency.

[Gap20-3] For large scale deployment, higher bandwidth network technologies are requirement, specifically in the CPN and AN segment.

In cloud-based object wave transmission, network latency and jitter requirements are application dependent. If the application only receives object wave data as a one-direction data stream and plays back holographic videos, the network latency requirements are the same as for general video streaming services. The network jitter can be compensated through buffering before playout. If the application delivers holographic videos in different interaction modes and in different user experience modes, as in Cloud VR [11], the network latency and network jitter requirements are the same as those for Cloud VR.

[R20-4] The network latency requirement shall be the same as in the Cloud VR latency requirements of Table 1 of clause 4.2 in ETSI GS F5G 013 [11].

The latency requirements are already fulfilled by the F5G-A network architecture [40].

[Gap20-4] None.

5.4.2.4 Control and Management Requirements

The location of the compute and storage functionality can be chosen depending on the availability of the required compute resources and network between the end user device and the object wave transmission rendering. Therefore, the allocation of a rendering task to a compute element needs to be chosen by the control and management functionality taking all constrains and the current usage into account.

[R20-5] The control and management of F5G-A shall support the function to dynamically allocate rendering tasks to compute elements in the network.

Since those converged compute and networking tasks are not traditionally performed independently, the control and management function need to be converged, and the appropriate management and control data models need to be developed.

[Gap20-5] Converged control and management of networking and compute protocols and data models are not standardized.

5.4.3 Current related standard specifications

5.4.3.1 ITU-T SG21

The ITU-T SG21 is in the process of defining the coding and system level requirements for this use case. See [i.45] for further information. The network level approach is using different technologies compared to F5G Advanced Network Architecture. Details of the new media system are for further study in ITU-T SG21.

5.5 P2MP fgOTN for premium private lines

5.5.1 Use Case Briefing

In the F5G Advanced era, with existing SDH phasing out and government and enterprise digital transformation happening, a massive amount of low-rate premium private lines are needed. This has motivated the development of a series of fine grain Optical Transport Network (fgOTN) recommendations by ITU-T and the F5G-A architecture with Point-to-Point (P2P) fgOTN connections by ETSI ISG F5G, inheriting Time Division Multiplexing (TDM) mechanism of SDH and OTN, providing hard pipe, guaranteed bandwidth and guaranteed performance.

However, P2P fgOTN faces some challenges in case of areas with high density services with insufficient P2P fibre connections, due to high cost of new fibres deployment, and lengthy service provisioning times. This use case describes a new scenario of leveraging existing point-to-multipoint (P2MP) fibre deployment (which is heavily used for residential services) to enable fgOTN over P2MP networks for transporting premium private lines. See Use Case # 21 in ETSI GR F5G 032 [i.35] for more details.

5.5.2 Technology Requirements and Gap Analyses

5.5.2.1 General

Currently, the operators are widely using OTN for transporting new premium private lines and migrating premium private lines in the existing SDH network to OTN. As illustrated in Figure 13, for the case of high-density area with a massive amount of low-rate premium private lines and with insufficient P2P fibre connections, the operators want to leverage existing P2MP fibre deployment to save the feeder fibres in the user/enterprise-to-access portion, where the fgOTN connection is carried over P2MP fibre network. The P2P fgOTN connection is still carried over the access-to-core portion. Consequently, the end-to-end fgOTN connection is carried over mixed P2MP fibre and P2P fibre. The fibre resources can be significantly saved, investment costs reduced, and migration efficiency improved, while the fgOTN connection quality is inherited.

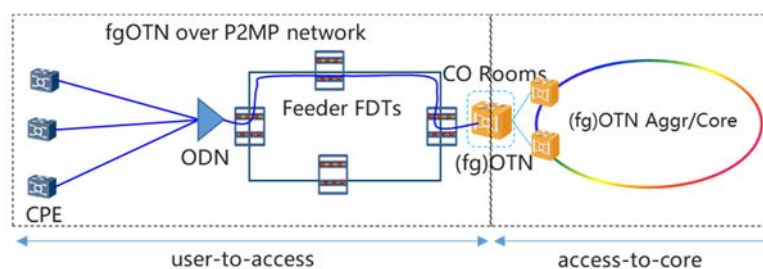

Figure 13: Overview of fgOTN over P2MP network

5.5.2.2 fgOTN over P2MP network

fgOTN over P2MP network for transporting the premium private lines needs to support the following functions and capabilities.

The premium private lines need to be carried over end-to-end fgOTN connections. fgOTN over P2MP fibre network is used in the user-to-access portion, and fgOTN over P2P fibre network is used in the access-to-core portion, so end-to-end fgOTN connection shall be supported over P2MP fibre network and P2P fibre network.

[R21-1] End-to-end fgOTN connection shall be supported over P2MP fibre network and P2P fibre network.

[Gap21-1] Standards which support end-to-end fgOTN connection over P2MP fibre network and P2P fibre network are currently unavailable.

The end-to-end network management and control system is used to manage private line services provisioning. Management system users need set up an end-to-end connection. In this way, private line services are provisioned and managed in a unified manner, simplifying the service provisioning process. The service provisioning and visualization include features such as SLA, fault, warning, and alarm capabilities.

[R21-2] For fgOTN over P2P and P2MP fibre network, end-to-end service provisioning and visualization shall be supported based on the unified network management and control.

[Gap21-2] Standards which support End-to-end fgOTN service provisioning and visualization are currently unavailable.

A single fgOTN node in Central Office (CO) room needs to support the aggregation of traffic from multiple CPE nodes. The split ratio of 1:8 to 1:16 of each P2MP network shall be supported based on the density and the bandwidth requirement of the services to be carried. The existing PON standard is capable of supporting the split ratio of 1:8 to 1:16. For the implementation of fgOTN over P2MP fibre networks, several PON components can be leveraged.

[R21-3] The split ratio of 1:8 to 1:16 of each P2MP network shall be supported.

[Gap21-3] None.

The services include various Ethernet (packet) services and Constant Bit Rate (CBR) services, which are eventually encapsulated into the fgOTN container carried over the P2MP network. Hitless bandwidth adjustment in the case of an fgOTN carrying an ETH service and CBR timing transparent transport in the case of an fgOTN carrying CBR service needs to be supported.

[R21-4] Hitless bandwidth adjustment in the case of an fgOTN (over P2P and P2MP) carrying an ETH service shall be supported.

[R21-5] In the case of an fgOTN (over P2P and P2MP), CBR timing transparent transport carrying CBR service shall be supported.

[Gap21-4] Standards which support hitless bandwidth adjustment for ETH service are currently unavailable.

[Gap21-5] Standards which support hitless bandwidth adjustment for timing transparent transport for CBR service are currently unavailable.

A real-time control service is required for dispatching and distribution automation services in power grid, such as relay protection, all of which demand millisecond-level latency and few tens of microseconds latency variation. So deterministic latency and low latency variation needs to be supported.

[R21-6] Millisecond-level latency and few tens of microseconds latency variation for P2MP network shall be supported.

[Gap21-6] Standards which support millisecond-level latency and few tens of microseconds latency variation for P2MP network are currently unavailable.

5.5.3 Current related standard specifications

5.5.3.1 ITU-T

ITU-T SG15 has developed a series of fine grain OTN recommendations and a series of PON recommendations which are widely deployed over the world. ITU-T SG15 also has developed a supplement to study application requirements and potential solution of fgODUflex over point-to-multipoint networks named G.Suppl.85:

- Recommendation ITU-T G.709.20 [2] (2023), Overview of fine grain OTN (fgOTN).
- Recommendation ITU-T G.9807.1 [i.53] (2023), 10-Gigabit-capable symmetric passive optical network (XGS-PON).
- Supplement ITU-T G Suppl.85(2025), fgODUflex over point-to-multipoint networks.

5.6 Smart Sensor Cloud for AI in Industrial Manufacturing

5.6.1 Use Case Briefing

The F5G-A use case for Smart Sensor Cloud aims to address inefficiencies in edge computing by leveraging centralized cloud-based AI processing. Traditional industrial systems rely on localized computation, which is costly and challenging to scale. With F5G-A's high bandwidth and low latency capability all sensor data - including high-resolution video, environmental metrics, and machine status - can be streamed directly to a cloud environment. This enables real-time AI processing and decision-making, optimizing manufacturing operations, reducing infrastructure complexity, and improving scalability.

By centralizing AI workloads, industries benefit from better resource utilization, simplified maintenance, and improved real-time responsiveness in applications like predictive maintenance, defect detection, and operational optimization. The Smart Sensor Cloud eliminates the need for edge AI devices, allowing industrial facilities to unify data processing across multiple sites efficiently. See Use Case # 22 in ETSI GR F5G 032 [i.35] for more details.

5.6.2 Technology Requirements and Gap Analyses

5.6.2.1 General

The Smart Sensor Cloud requires robust networking and AI processing capabilities to support real-time data transmission, processing, and decision-making. The shift from edge computing to a centralized AI model introduces new demands on network speed, latency, and security.

5.6.2.2 Latency

Latency is a critical factor in the performance of industrial automation systems, affecting real-time data analysis and machine response times. The latency requirements derive from the latency requirements defined in the ANSI/ISA-95.00.01 [41]. For Production Process Level and SCADA applications the system shall guarantee latency of less than 1 ms.

- [R22-1] The F5G-A network for process level applications shall guarantee a latency of less than 1 ms.
- [R22-2] For motion control applications the latency shall be less than 0,5 ms.
- [Gap22-1] None.
- [Gap22-2] Motion control latency of lower than 0,5 ms not currently available in standards.

5.6.2.3 Bandwidth

The effectiveness of the Smart Sensor Cloud relies on high-bandwidth, low-latency fibre-optic networks.

- [R22-3] The network backbone connecting a manufacturing site shall support data rates between 10 Gbit/s and 1 Tbit/s, depending on factory requirements and size.
- [R22-4] The network shall ensure redundancy through multiple fibre pathways and failover mechanisms to prevent downtime.
- [R22-5] The last-mile connection to sensors shall support at least 1 Gbit/s to handle high-resolution sensor data and real-time streaming.
- [Gap22-3] None.
- [Gap22-4] None.
- [Gap22-5] None.

5.6.2.4 Security

Data security is essential for Smart Sensor Cloud operations, given the sensitive nature of industrial data.

- [R22-6] The system shall comply with industry-specific security standards and regulations, including ISO/SAE 21434 [42] (Automotive Cybersecurity), IEC 62443-1-1 [43] (Industrial Network Security), and Regulation (EU) 2016/679 [44] (General Data Protection Regulation (GDPR)) for data privacy.
- [R22-7] The system shall implement secure authentication and access control mechanisms to prevent unauthorized access to industrial data.
- [R22-8] The system shall provide auditability and traceability of all data transactions to ensure compliance with industry norms and forensic analysis capabilities.
- [R22-9] The system shall incorporate real-time anomaly detection and intrusion prevention mechanisms tailored for AI-driven industrial automation.

Despite advancements in cybersecurity, gaps remain in seamless security integration across cloud-based AI industrial automation.

- [Gap22-6] End to end security across optical access and optical core network technology is not standardized on the optical and electrical layer, however it can be done with security standards on higher layers.
- [Gap22-7] None.
- [Gap22-8] Auditability and traceability on the F5G-A network is not standardized.
- [Gap22-9] Anomaly detection and intrusion prevention standards are not available.

5.6.3 Current related standard specifications

The extreme low latency is currently not achievable with standards solutions. The bandwidth requirements can be fulfilled with the current optical networking standards like 50G-PON and B1T OTN.

5.7 Integrated NAS over FTTR

5.7.1 Use Case Briefing

The integrated NAS (Network Attached Storage) over FTTR leverages the resources and management of the fibre network, creating a distributed storage network with enhanced reliability and performance. This integration offers several significant advantages. The FTTR network identifies and prioritizes NAS traffic, enabling multi-gigabit throughput and sub-millisecond latency for scenarios like large file transfers and real-time 4K/8K video editing. It can also reduce the number of standalone devices, simplify cabling, and save energy by reducing optical-electrical conversions. Acts as a home edge computing node for local AI processing (e.g. photo classification, video analysis), the integrated NAS over FTTR reduces cloud dependence and enhance privacy of user data. For service providers, it enables new business models like high-value "FTTR + NAS" packages and Storage-as-a-Service (STaaS) with cloud synchronization. See Use Case # 23 in ETSI GR F5G 032 [i.35] for more details.

5.7.2 Technology Requirements and Gap Analyses

5.7.2.1 General

There are multiple network elements involved, including a cloud platform at the service provider's network, a FTTR system in the user's premises and storage units inside the FTTR devices. For successful implementation of integrated NAS over FTTR, all these elements shall be able to work co-ordinately. As there could be important data in the NAS, the safety and security of the system shall be provided to prevent data loss. A smart O&M system allows service providers to remotely manage and monitor NAS performance.

5.7.2.2 Reliability of user's data on NAS

For home storage products, the reliability that users are concerned about mainly involve two dimensions: Durability (whether data is lost) and Availability (whether the data is accessible). For example, during a certain period, although the data on the storage remains intact, users may temporarily be unable to access the data due to server or network failures. Therefore, reliability is required both on the device layer and on the network layer. To ensure reliable operation, the non-permanent faults shall be repaired automatically once the system detects such faults. Besides, the controller shall support monitoring of critical components. In case of abnormal events, it shall initiate protective measures to prevent physical damage to the components, accompanied by alarm notifications. Memory and system reliability shall be ensured through power-on self-tests and other methods to guarantee normal storage operation. Since the risk of hardware failure always exists, the network data protection over the FTTR system is required. It can prevent data loss due to hard drive failures, disasters, or human errors.

- [R23-1] NAS over FTTR shall support data durability through network data protection technology, specifically cloud data backup technology of transmitting local data to cloud storage space via the network, enabling offsite backup and recovery of data.
- [Gap23-1] The detailed network data protection for the NAS over FTTR system is not available.

5.7.2.3 Security

To ensure the overall security of the integrated NAS over FTTR, the system should provide security capabilities in five aspects: hardware security, system security, network security, data security, and application security.

- [R23-2] The FTTR system shall provide encrypted transmission capabilities to support both remote access to the NAS through the home storage APP (mobile phone application) and the security of data transmission over networks and between the MFU and SFUs.
- [R23-3] The FTTR devices (specifically the MFU) should have firewall functionality, including remote external network firewalls and internal business firewalls.
- [R23-4] The integrated NAS over FTTR devices should have mutual identity authentication capabilities to prevent impersonation of MFU and SFUs.

Applications that support family storage should have the capability to access family storage data with secure authentication and authorization. Applications supporting family storage should avoid hardcoding sensitive data and should have the ability to prevent reverse engineering to defend against information leakage.

- [R23-5] APP level security shall be supported.
- [Gap23-2] Although the secure transmission mechanism is supported by the PON and FTTR standards, the encryption and authentication are often disabled. Therefore, encryption and authentication mechanism specified for NAS application are often not available.
- [Gap23-3] None.
- [Gap23-4] None.
- [Gap23-5] There is no specific security requirement or standard on APP level for user's home storage.

5.7.2.4 High performance for the network access

To ensure that users can quickly upload and download large files, such as high-definition photos and videos, when accessing the home storage system within the household, high bandwidth is required for the FTTR network. Users should feel no delay during operations, thereby enhancing real-time interactive experiences, such as online photo or video editing, low latency transmission channel is required.

- [R23-6] Without affecting network services, FTTR should provide bandwidth greater than 1 000 Mbps.
- [R23-7] FTTR should offer a data transmission channel with latency of less than 15 ms.
- [R23-8] FTTR should be capable of providing data access through a peer-to-peer channel with a bandwidth greater than 100Mbps for remote access to improve work efficiency and data availability.

- [Gap23-6] High bandwidth access should be provided for the NAS access by the FTTR network. Currently, the bandwidth of the fibre network is enough, while the bandwidth of the Wi-Fi® network is not guaranteed.
- [Gap23-7] Low latency for the data transmission channel is not defined in any FTTR related standard.
- [Gap23-8] An APP-flow based E2E network slicing function is a good approach to support remote access of integrated NAS over FTTR. There is no APP-flow level network slicing in current standards.

5.7.3 Current related standard specifications

5.7.3.1 ITU-T

ITU-T SG15 has been actively developing standards for FTTR technology. Key technical developments include:

- Recommendation ITU-T G.9941 [8]: This standard defines the physical layer specifications for FTTR, including parameters for 2.5G physical layer.
- Recommendation ITU-T G.9942 [9]: This standard specifies the data link layer technical schemes for FTTR.

With these two standards, 2.5G bandwidth can be provided by the fibre-based home network.

In Recommendation ITU-T G.9942 [9], system authentication, data integrity, and privacy protection are considered. The authentication mechanism is used as a network admission control function and Registration-ID or Password based authentication is specified as mandatory in data link layer. Besides, Advanced Encryption Standard (AES) and SM4 is specified as the data channel encryption algorithm. However, only downstream encryption with CTR mode is defined as shown in Figure 14.

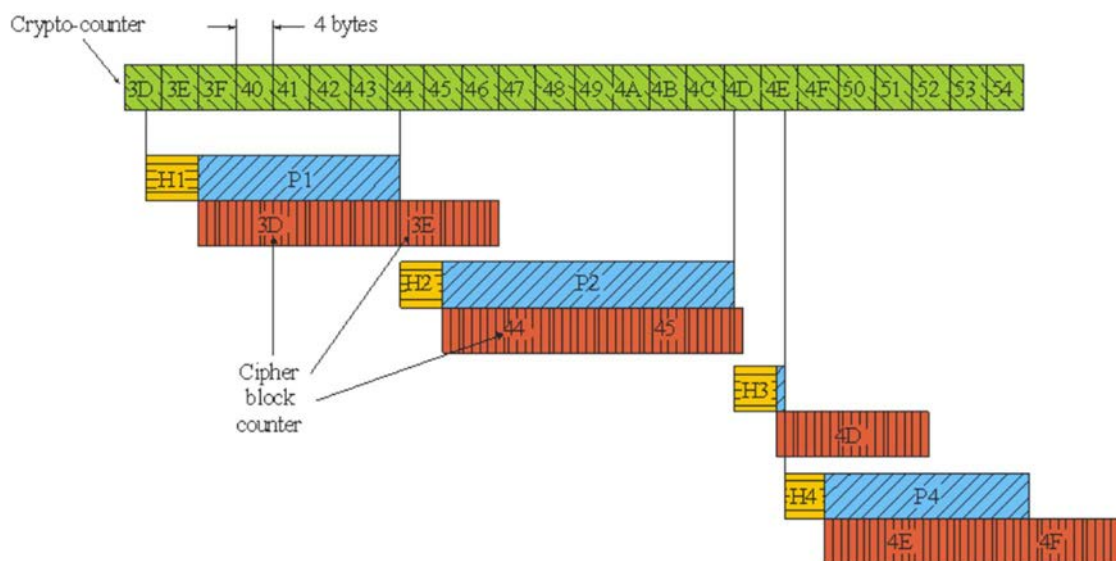

Figure 14: Data channel encryption of FTTR system in Recommendation ITU-T G.9942 [9]

ITU-T G.Sup89 [i.62]: A new work item, G.Sup89 ("Cooperative Management of Access and Fibre Premises networks"), was established. This project aims to research key technologies for PON and FTTR collaboration. This is intended to support end-to-end slicing in broadband access networks.

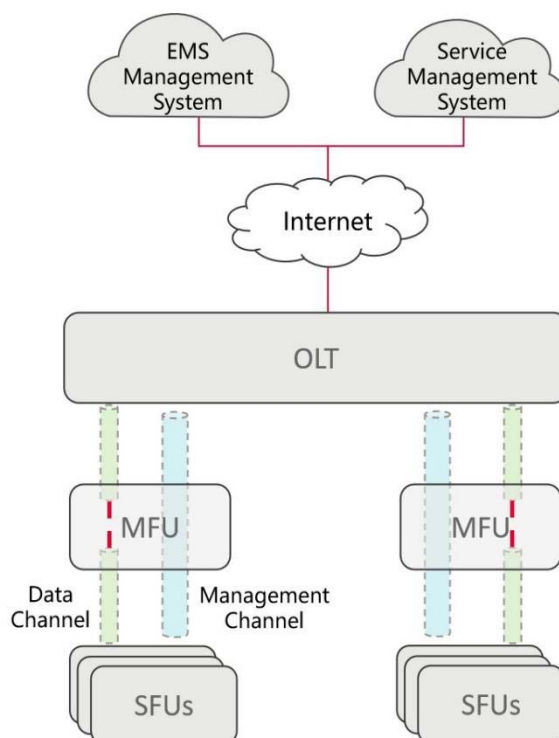

Figure 15: PON and FTTR collaboration management in ITU-T G.Sup89 [i.62]

5.7.3.2 CCSA

The CCSA has been developing series of standards for FTTR technology, recognizing its importance in extending gigabit broadband connectivity from FTTH to FTTR for home or small enterprise. This work often runs in parallel with ITU-T. Besides, there are also two FTTR equipment requirement standards (one for residential users and one for SME users). In these FTTR equipment standards, integrated NAS over FTTR is specified as an optional feature and there are no detailed requirements for this feature.

5.7.3.3 ETSI

ETSI TC Cyber has developed standards to address cybersecurity and privacy for consumer Internet of Things (IoT) devices, including home gateways. The most relevant standards are ETSI EN 303 645 [i.58] and EN 18031 series [i.59]:

- ETSI EN 303 645 [i.58] is a baseline security standard for consumer IoT devices, including home gateways, smart cameras, wearables, and smart home systems. For secure data storage and transmission specified in ETSI EN 303 645 [i.58], user data shall be encrypted (e.g. using AES-256), and secure communication protocols (e.g. TLS 1.3) are required.
- EN 18031 series [i.59] is a harmonized standard series under the EU Radio Equipment Directive (RED). There are some requirements:
 - Resilience mechanisms: Devices should withstand DDoS attacks and self-recover after security incidents.
 - Enhanced privacy: Stricter access controls and data anonymization for privacy-sensitive devices.
 - Hardware security: Secure boot and hardware-based key storage for critical devices.

ETSI plans to update ETSI EN 303 645 [i.58] to include IoT security (e.g. data isolation for voice assistants) and edge computing node protection. EN 18031 [i.59] will also align with the EU Cyber Resilience Act (CRA).

5.8 Generating an Energy Map for sustainable F5G-Advanced networks infrastructure

5.8.1 Use Case Briefing

In F5G-Advanced networks, high energy consumption is a critical concern, requiring network operators to adopt advance energy-efficient strategies. By creating an energy map overlaid on a network infrastructure, it can provide a detailed information about total energy utilization, including both consumption and generation. The energy map should consider energy consumption by network systems, computing systems as well as environmental control systems. Additionally, it considers energy generation from both local renewable sources and external energy sources. Furthermore, it can measure the temperature of the network and computing facilities. This approach enables network operators to reduce dependencies on non-renewable sources, lowers operational costs, improve sustainability and optimizes energy efficiency. See Use Case # 24 in ETSI GR F5G 032 [i.35] for more details.

5.8.2 Technology Requirements and Gap Analyses

5.8.2.1 General

To build a topology-overlaid energy-map for F5G-A networks to achieve energy efficiency requires the following functional chain.

The system should support granular and model-driven telemetry to collect all required energy metrics from different sources and from all relevant domains. The system should support correlation of energy utilization data with price and energy source. The system should support time-series data storage with high-availability and performance along with fast access. The system should provide recommendations to improve network energy efficiency.

Although existing standards and architectures address many of these requirements, several gaps remain to be resolved before an energy efficiency management system can be fully implemented in the F5G-A infrastructure.

5.8.2.2 Energy Watcher

The Energy Watcher component should gather real-time telemetry and energy consumption across the F5G-Advanced network infrastructures. It should monitor network elements and environment control systems such as heating, ventilation, and air conditioning (HVAC) units. It should also track energy sources from local sources compared to external sources. This continues monitoring provides the fundamental data needed to create an energy efficiency map.

[R24-1] The Energy Watcher shall provide a continuous stream of network traffic, energy utilization and environmental metrics from all relevant sources and domains in real-time.

This requires network devices and sensors to expose monitoring information via model-driven telemetry. The Energy Watcher should ensure to collect monitoring data with minimal latency and overhead.

[R24-2] The Energy Watcher shall extract telemetry from heterogenous sources such as network equipment, sensors, and HVAC systems and energy supply systems.

This implies Energy Watcher should have capabilities to properly interface with network devices, HVAC systems and local and external power sources to collect energy usage data.

[R24-3] The Energy Watcher shall corelate monitored energy consumption data with the corresponding network elements and locations.

This means Energy Watcher should know the energy consumed is coming from local or external source.

[Gap24-1] No standard YANG data model to report energy consumption of network devices.

While there are standards to expose device operational data. The IETF has active drafts building YANG models for energy efficiency monitoring, but they are not standardized yet. Most of current implementation is vendor specific.

[Gap24-2] No standard model-driven approach that provides energy data from HVAC and energy supply systems.

[Gap24-3] No standard YANG model that defines energy efficiency metrics.

There are initial drafts that defines energy saving and power management metrics, but they are not standardized yet.

5.8.2.3 Energy Cost Calculator

The Energy Cost Calculator should provide analysis and translate raw measurement from Energy Watcher into cost metrics. This means incorporating energy consumption data with factors such as energy sources, time of use and pricing to compute operational cost of energy usage.

[R24-4] The Energy Cost Calculator shall compute energy cost by combining both network energy consumption with energy source and pricing.

This means energy cost calculation should consider how much energy is drawn from what source (internal or external) and should incorporate time-varying energy pricing.

[R24-5] The Energy Cost Calculator shall provide optimized insights and forecast future consumption and costs by leveraging AI/ML models.

This means the Energy Cost Calculator should identify hidden patterns, detect anomalies and utilize historical monitoring data to predict future energy usage.

[Gap24-4] No standardized energy efficiency metrics to streamline to cost calculation logic.

The energy cost calculation logic is defined in a custom manner mostly driven by the business rules but standardizing the energy efficiency metrics can help streamline this process.

[Gap24-5] No standard interface is defined integrate AI/ML predication/recommendation to controller.

This means if the AI/ML model determines that certain ports should be placed in low-power mode, currently there is no standard message to convey this decision to controller.

5.8.2.4 Storage Database

The Storage Database should provide reliable and persistent storage for all telemetry and computed energy metrics. This database should be designed for high availability and performance, as it should ingest continuous telemetry stream and provide historical data.

[R24-6] The Storage Database shall provide high-throughput telemetry storage without loss or significant delay.

This implies that the database should provide high write throughput with scalability. The data should ingest data stream in real-time with minimal buffering.

[R24-7] The Storage Database shall provide high data retention and easy and fast data access.

The database should retain historical energy data and calculated metrics for a long time along with efficient querying and retrieval capabilities. The database should support secure time-based and aggregation-based querying.

Currently available database supports all popular data encodings to perform operations on stored data along with high availability and redundancy.

EXAMPLE: The data encoding scheme may be JavaScript Object Notation (JSON).

[Gap24-6] None.

[Gap24-7] None.

5.8.2.5 Energy Map Generator

The Energy Map Generator should provide visual representation of energy data overlays on the F5G-A network topology, producing maps that highlights energy hotspots and green energy share. With AI/ML integration, the Energy Map Generator should recommend network reconfiguration to improve energy efficiency and help in decision-making.

- [R24-8] The Energy Map Generator shall be able to correlate energy efficiency metrics with network topology and inventory information to generate meaningful overlays.

This means map generator should have knowledge of network structure and real-time and historical energy monitoring data to map energy metrics to network elements.

- [R24-9] The Energy Map Generator shall generate energy hotspots based on historical energy monitoring data.

This means map generator should retrieve all relevant data to produce energy map accordingly. The map should help diagnose past issues and observe how past optimizations are working.

- [R24-10] The Energy Map Generator shall provide recommendations for network reconfiguration to improve energy efficiency.

This means the map generator should provide decision making support to the controller to help reduce energy inefficiencies.

- [Gap24-8] No standard model or schema for creating an energy map that combines network topology and energy metrics.

There should a ready-made energy overlay maps but currently all maps are vendor specific and build on generic energy data.

- [Gap24-9] None.

- [Gap24-10] No standard interface to feed energy decision back to controller.

There are APIs that may be leveraged to communicate decisions, but no explicit energy-based commands are available.

5.8.3 Current related standard specifications

5.8.3.1 IETF

- IETF RFC 9232 [38] describes architectural framework for network telemetry, facilitating efficient and automated network management as published in 2022.
- IETF RFC 8343 [35] standard model for basic interface statistics and configuration as published in 2018.
- IETF RFC 8639 [37] provide YANG model to subscribe to network element, as published in 2019.
- IETF RFC 8345 [36] defines an abstract (generic, or base) YANG data model for network/service topologies and inventories as published in 2019.

IETF is now developing a set of YANG data models to integrate energy efficiency metrics:

- IETF draft-cwbgp-green-common-energy-management [i.38], which specifics YANG models that combines network topology, power management and network inventory models.
- IETF draft-neumann-green-streaming-yang [i.36], which defines a YANG model to represent device energy measurements. It supports instantaneous power readings and correlated metrics for energy efficiency.
- IETF draft-stephan-green-ucs-and-reqs [i.37], which defines collecting and updating requirements for the management of energy-efficient networks and defining use cases for managing energy-efficient networks.
- IETF RFC 9845 [i.39], defines a set of opportunities, along with associated research challenges, for networking technology in general and management technology in particular to become "greener".

5.8.3.2 OpenConfig

- OpenConfig-platform v0.31.0. [i.44] defines data model which creates the configuration for the telemetry systems and functions on the device.

5.8.3.3 ITU-T

- Y.3187 [i.47] defines how ML functions can be orchestrated in networks, which could facilitate integrating external AI/ML with network controllers.

5.9 Flat wheel detection using Distributed Acoustic Sensing (DAS)

5.9.1 Use Case Briefing

The objective of this use case is to utilize optical fibre cables, ideally already deployed, along railway corridors (primarily for telecommunication purposes, see Figure 16) as distributed vibration sensors for detecting wheel flats and related rolling-stock defects. Leveraging in-place telecommunication fibre for flat wheel detection presents a highly cost-effective and scalable monitoring solution.

The sensing principle is based on Distributed Acoustic Sensing (DAS), where acoustic vibrations caused by wheel–rail impacts are captured along the fibre, analysed, and classified to identify abnormal wheel conditions.

This approach eliminates the cost and complexity associated with installing dedicated sensing fibres while providing continuous, large-scale monitoring coverage.

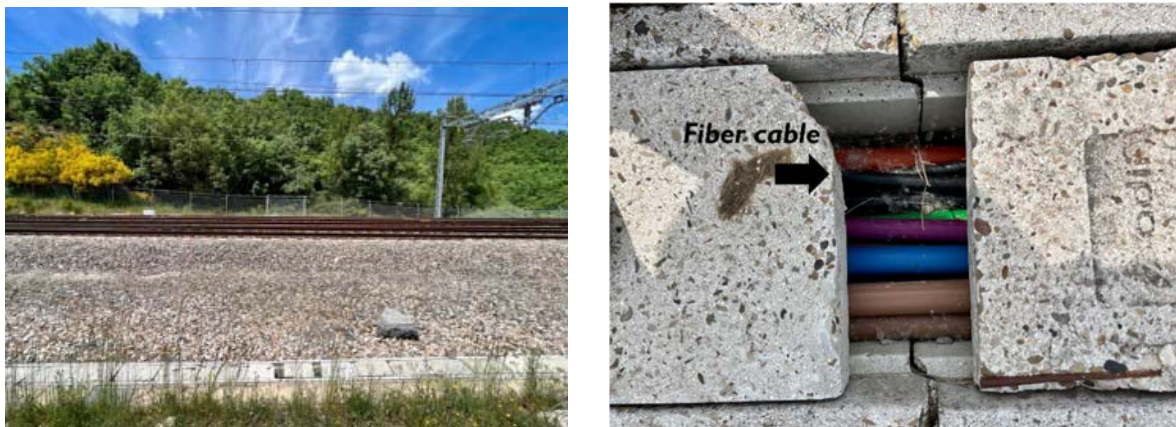

Figure 16: Layout of the cable conduit and placement of optical fibres used for telecommunication

5.9.2 Technology Requirements and Gap Analyses

5.9.2.1 General

Widespread adoption and certification are impeded by non-technical gaps. The absence of standardized performance metrics, calibration methods, mechanical coupling guidelines, and data interfaces creates uncertainty and limits interoperability. Therefore, while the technology is mature enough for operational pilots, closing these identified standardization gaps is the critical to enable reliable, vendor-neutral, and safety-certified deployments.

5.9.2.2 Detection Latency

- [R25-1] The system shall identify and report a wheel flat event within ≤ 10 seconds from the train passage to enable near-real-time alerting.
- [Gap25-1] Deploy analytical signal-processing methods to detect periodic vibration peaks caused by flat wheels, and leverage AI/ML models to classify and rule out of other causes. No deep learning and machine learning databank to improve detection accuracy over time does exist and is not standardized.

5.9.2.3 Localization accuracy

- [R25-2] The position of a defect shall be detected with an accuracy of ± 10 m along the fibre span.
- [Gap25-2] Mapping between fibre length and track GPS coordinates is typically maintained in a Geographic Information System (GIS) file. This mapping can be refined through tapping tests and by leveraging GPS data from regular train operations, which are transmitted to the server to automatically correct positioning errors.

5.9.2.4 Detection sensitivity

Higher train speeds produce stronger wheel–rail impact forces and sharper transient signatures, improving detection Signal-to-Noise Ratio (SNR). Therefore, detection performance increases with train speed. The flat-wheel detection threshold depends on both defect size and train speed. For typical fibre coupling, a minimum wheel-flat depth of 0,3 - 0,5 mm at ≥ 60 km/h yields a detectable vibration above noise.

- [R25-3] The system shall detect wheel flat with impact energy equivalent to a $\geq 0,3$ mm flat depth at train speeds above 60 km/h.
- [Gap25-3] A standard procedure to ensure that vendor-specific technologies achieve the required detection sensitivity, along with standardized methods for verifying impact detection thresholds does not exist.

5.9.2.5 Data Throughput

- [R25-4] The DAS interrogator shall process and stream data at a ≥ 1 kHz sampling rate per channel, ensuring sufficient temporal resolution to capture wheel–rail impact signals.
- [Gap25-4] Reduce network or edge-compute bottlenecks that limit real-time processing and data transmission, along with challenges in scaling storage and analysis.

5.9.2.6 Availability / uptime

- [R25-5] The monitoring system shall maintain $\geq 99,5$ % operational availability during railway service hours.
- [Gap25-5] Deployments shall use a computing server infrastructure with redundant components and high-availability architecture. Maintenance windows shall be scheduled during non-operational hours (e.g. nights) to minimize disruption to continuous data acquisition and ensure uninterrupted system integrity.

5.9.2.7 Environmental robustness

- [R25-6] Fibre and interrogation equipment shall operate within -20 °C to $+60$ °C, with no degradation in sensing performance.
- [Gap25-6] To verify whether additional protective measures (e.g. climate-controlled housing) are required to maintain consistent sensitivity under extreme conditions.

NOTE: Assessing potential environmental factors such as humidity, vibration, UV exposure, and mechanical stress that may affect long-term performance are for further study.

5.9.2.8 Networking delay tolerance

- [R25-7] End-to-end data transmission (from the DAS unit to analytics platform) shall exhibit ≤ 200 ms latency, ensuring timely defect reporting.
- [Gap25-7] Assess network delays, edge-compute buffering, and overall infrastructure to ensure the ≤ 200 ms end-to-end latency requirement is met under peak load.

5.9.2.9 Integration

- [R25-8] The system shall integrate with existing asset management or alarm systems via standardized APIs.
- [Gap25-8] A gap exists in the standardization of alerts and their formats. Railway operators could initially use their own formats and gradually work toward a common standard through a rail operator consortium.

Burying the fibre at a depth of 15–30 cm is recommended. A depth of 15 cm provides mechanical protection while maintaining effective vibration coupling to ground-borne rail signals and is easy to implement. Depths between 15 cm and 30 cm generally provide acceptable performance. Standard single-mode fibres (Recommendation ITU-T G.652.D [48]) are adequate. However, mechanical coupling and installation configuration (clamped vs. loose) critically affect performance. No special fibre type is needed.

- [R25-9] Fibre should be buried in the range of 15 to 30 cm below the ground for acceptable performance.
- [Gap25-9] None

5.10 Integrated RFID over FTTR

5.10.1 Use Case Briefing

Passive Internet of Things (IoT) plays an important role in industrial evolution and digital transformation. Passive Ultra-High Frequency (UHF) RFID technology is one of the widely deployed solutions for asset management, logistics and warehousing. The integrated RFID over FTTR is capable to achieve people awareness and recognize objects/environment status by identifying passive RFID tags attached to them. Compared to the traditional RFID technology based on handheld or checkpoint readers, FTTR-based RFID technology brings breakthroughs of coverage limitation and supports coordinated management and control of RFID readers. See Use Case # 26 in ETSI GR F5G 032 [i.35] for more details.

5.10.2 Technology Requirements and Gap Analyses

5.10.2.1 General

The technology requirements of integrated RFID over FTTR mainly contains three major aspects: First, the UHF RFID adopts serial communication mechanism of "listen-before-talk" which is sensitive to the latency of FTTR network. Second, the coordination of multiple RFID readers requires accurate time and frequency synchronization via the FTTR network, therefore, implementing distributed beamforming of RF wave and location of RFID tags. Finally, the FTTR network shall provide coordinated control and management of this distributed RFID system.

5.10.2.2 Low latency channel for exchanging RFID protocol message

Due to the passive characteristics of RFID tags, the RFID protocol imposes strict communication latency requirements. When the FTTR network carries RFID protocol messages, the latency of RFID messages between two FTTR network devices (MFU/SFUs) shall obey the timing requirements specified by the RFID protocol. For example, in the case of the RFID protocol implementation integrated in the MFU, different SFUs are responsible for receiving and emitting RF signals. The latency of message from the receiving SFU to the MFU, and finally to the sending SFU is introduced to the RFID communication process.

The ISO/IEC 18000-63 [45] protocol defines the Backscatter Link Frequency (BLF) to represent the tag modulation rate. In particular, the time from the tag response to the reader transmission is defined as T_2 , including both transmission time and processing time between or within the RFID devices, and the time over the FTTR system. In fact, T_2 is dominated by the latency between different SFUs. The maximum T_2 is reversely proportional to the BLF (Maximum transmission latency = $\frac{20}{BLF}$, refer to Table 6-16 in [45]), and several commonly used values are shown in Table 1. The current FTTR network is unable to satisfy the requirement to support BLF over 320kbps and above. The transmission latency of the FTTR network determines whether the inventory process for a single tag can be successful, while higher BLF means higher inventory throughput. Therefore, low and stable transmission latency is necessary and beneficial for the RFID over FTTR network.

Table 1: Maximum transmission latency of RFID corresponding to different BLF

BLF (kbps)	Maximum transmission latency (μ s)
40	500
80	250
160	125
320	62,5
640	31,25

[R26-1] The FTTR network shall support low transmission latency below the maximum transmission latency as shown in Table 1 for exchanging RFID protocol messages at different BLFs.

[Gap26-1] The current FTTR network can support 64 micro seconds (μ s) [7] transmission latency for 160 kbps BLF but cannot satisfies the requirement of higher BLF.

5.10.2.3 High accuracy of frequency and time synchronization for distributed beamforming

In the integrated RFID over FTTR network, multiple SFUs transmit RF signals simultaneously. When delicate phase and frequency relationships of multiple RF signals are met, distributed beamforming based on coherent effects can improve the link budget for larger coverage and gain diversity reception. Since the sending timing of RFID signals can be controlled by the FTTR system, the coherent state of such signals can be achieved. This feature requires highly accurate frequency and time synchronization between MFU/SFUs.

For the superimposed waveform by beamforming, insufficient time synchronization causes worse modulation depth and widen Full Width Half Maximum (FWHM), resulting in higher transmission errors probability. According to ISO/IEC 18000-63 [45], the minimum modulation depth of the RF waveform is 0.8 and the FWHM cannot exceed 0,525 Tari (i.e. Tari is the standardized reference time interval in RFID coding). Therefore, the FTTR network shall provide accurate time synchronization of sub-microseconds to ensure superimposed waveform satisfying the RF envelope requirements in ISO/IEC 18000-63 [45].

In addition, the frequency synchronization is the foundation of coherence between RF waveforms generated from different SFUs. In the RFID over FTTR system, the FTTR frequency synchronization determines the coherence of RFID signals. For inventory capability, the coherent time of RF signals should be larger than the time of query, which is the longest message in the inventory process. The typical time for this is below 10 ms. Therefore, the frequency jitter should be less than $1/10 \text{ ms} = 100 \text{ Hz}$, which means that the frequency jitter should be less than 100 Hz if the coherence time needs to be 10 ms. This value leads to 0,1 ppm frequency synchronization based on RFID operating frequency of 900 MHz.

According to the PON standard [33], the above time and frequency synchronization is achievable in xPON systems but there is no definite standard in FTTR network.

[R26-2] The FTTR network shall provide sub-microsecond time synchronization in case of supporting beamforming.

[R26-3] The FTTR network shall provide less than 0.1ppm frequency synchronization in case of supporting beamforming.

[Gap26-2] The ability of sub-microsecond time synchronization is not supported in FTTR network.

[Gap26-3] The ability of frequency synchronization is not supported in FTTR network.

5.10.2.4 Coordinated control and management for integrated RFID over FTTR

To achieve a centralized view of the entire system, the FTTR network shall implement coordinated control and management mechanisms for the distributed RFID system. This mechanism enables dynamic switching between RFID receiving and emitting roles by the MFU according to the environmental characteristics. For example, the emitting SFU need to be closer to the RFID tags since the passive tag's sensitivity is limited. Besides, the MFU shall also monitor and configure the operating status of each RFID reader, such as the utilization of RF channel, modulation rates, and other physical and MAC layer parameters, to optimize the operating performance of RFID system.

[R26-4] The integrated RFID over FTTR system shall support coordinated control and management of FTTR and RFID.

- [R26-5] The coordinated control and management of FTTR and RFID shall monitor the operating status of RFID readers and configure the corresponding technical parameters to optimize RFID functionality.
- [Gap26-4] The coordinated control and management of FTTR and RFID currently not available.
- [Gap26-5] The monitoring and configuring of RFID readers over FTTR is currently not available.

5.10.3 Current related standard specifications

5.10.3.1 ISO/IEC 18000-63: The Global Benchmark of RFID

ISO/IEC 18000-63 [45], as a crucial component of the ISO/IEC 18000 series standards, focuses on defining the air interface communication protocol for Ultra-High Frequency (UHF) Radio Frequency Identification (RFID), applicable to passive tag systems within the 860 MHz to 960MHz frequency band. This standard specifies the operational mechanism of passive backscatter technology: the interrogator (reader) activates tags by transmitting a Continuous Wave (CW) radio frequency signal, while tags respond by modulating their antenna reflection coefficient to backscatter information signals, enabling data interaction. The system adopts an Interrogator-Talks-First (ITF) mode, meaning tags respond only after receiving explicit instructions from the interrogator, preventing unnecessary signal interference.

In the physical layer design, the standard defines the forward link to use Pulse-Interval Encoding (PIE), while the reverse link supports multiple modulation schemes, ensuring efficient data transmission and noise resistance. The standard defines in detail the RF envelope requirements both of the reader to tag and tag to reader, such as modulation depth, RF envelope ripple, rise time, fall time, pulse width, etc. The standard also defines the link rate of both cases, raising the strict timing requirements. The logical operations section covers command sets and protocol procedures, including tag initialization by the interrogator, data read/write processes, and state management. To address collision issues in multi-tag environments, the standard integrates a random slotted collision-arbitration algorithm, which reduces response collisions through dynamic time slot allocation, enhancing identification efficiency and throughput. Additionally, ISO/IEC 18000-63 [45] provides optional security extensions supporting the ISO/IEC 29167 [i.60] cryptographic suite for implementing data encryption, integrity verification, and key management, thereby strengthening communication security.

This standard maintains high compatibility with the EPC global UHF Class 1 Generation 2 specification and is widely applied in global supply chain management, logistics, and retail sectors, ensuring cross-vendor device interoperability. Its evolution includes the consolidation of Type C protocols in the 2013 edition and updates in the 2021 edition, with the latter reinforcing industrial innovation requirements while keeping the core framework stable.

5.10.3.2 ETSI EN 302 208 (European RFID Standard)

Europe enforces stricter transmit power limits (max 2W ERP) and mandates Listen Before Talk (LBT) to prevent channel collisions (ETSI EN 302 208 [46]). Operating in 865–868 MHz, it employs Dynamic Frequency Selection (DFS) to avoid interference with military bands. This design prioritizes spectral coexistence in dense industrial environments.

5.10.3.3 ITU-T SG15

The specifications for the FTTR system are defined in ITU-T SG15 Q3. For the FTTR standardization progress, refer to clause 4.3.3.1 in the present document.

5.11 AI-Powered Intelligent Flash Disconnection Fault Localization in Optical Network

5.11.1 Use Case Briefing

Fibre flash disconnection faults represent a critical challenge in optical network operations, severely impacting service continuity, operational costs, and overall network reliability. Such faults lead to service interruptions or performance degradation, especially in latency-sensitive applications like video conferencing and financial transactions, resulting in increased customer complaints and SLA violations. Additionally, frequent disconnections accelerate hardware aging and trigger redundant protection mechanisms, raising operational and maintenance (O&M) expenses. Traditional fault localization methods, primarily reliant on manual inspections and Optical Time Domain Reflectometer (OTDR) testing, suffer from inefficiencies - often requiring 1-2 hours for diagnosis - and exhibit high false detection rates, particularly for hidden or transient faults.

Common causes of flash disconnections include abnormal optical power jitter, transient cable interruptions, fibre deterioration, sporadic equipment failures, and on-site operations etc. Existing approaches struggle to accurately identify and locate these issues, forcing operators to expend up to 30 % of O&M resources on manual fault rectification. To address these limitations, this use case introduces an AI-powered solution designed to enable rapid, accurate, and automated localization of flash disconnection faults, thereby enhancing operational efficiency and network reliability. See Use Case # 27 in ETSI GR F5G 032 [i.35] for more details.

5.11.2 Technology Requirements and Gap Analyses

5.11.2.1 General

Traditional flash disconnection localization relies on manual experience and physical tools (e.g. OTDR, optical power meters), suffering from low efficiency, high mis-judgment rates (due to event blind zones and meter-level errors), and inability to predict faults or analyse root causes. Subjective manual judgments also lead to misinterpretations, such as mistaking power instability for fibre cuts, wasting redundancy resources.

The AI-powered solution deploys Fast OTDR and AI capabilities at network nodes (e.g. OTM, OLA, ROADM) for millisecond-level monitoring and scanning. Integrated with OSC and CNN-based algorithms, it automatically identifies fault patterns (e.g. board failures, connector loosening, fibre bends) by analysing optical power curves. Fault details are visualized on the NMS for rapid diagnosis. This approach enables proactive prediction, root-cause analysis, and minute-level self-healing, transforming optical network O&M from passive response to intelligent proactive protection.

5.11.2.2 Flash disconnection fault localization performance

AI-powered flash disconnection fault localization technology shall support the following functions and capabilities:

- [R27-1] The detection range should be at least over 140 km to accommodate all span distance scenarios in operators.
- [Gap27-1] Currently, the industry's capabilities can only achieve a range of approximately 80~120km.
- [R27-2] The localization accuracy shall be within ± 20 meters.
- [Gap27-2] At present, such a localization accuracy of ± 20 m is generally achievable in the industry.
- [R27-3] The near-end event blind zone should be less than 100 meters.
- [Gap27-3] Currently, the near-end event blind zone in the industry can only achieve a level of 500 meters.

The near-end blind zone refers to the initial distance range where an OTDR cannot detect faults immediately after the test starts, due to receiver saturation caused by the strong initial pulse. This physical limitation results in undetectable events (e.g. connectors or micro-bends) within this zone. A smaller near-end blind zone indicates better system performance.

- [R27-4] The flash disconnection fault localization shall support a detection time lower than 200 ms.

- [Gap27-4] Regarding detection time, some in the industry can achieve minute-level, but most still operate at the hour level.
- [R27-5] The flash disconnection fault localization shall support accurately identifying flash disconnection faults of fibre bending, fibre cutting, and fibre connector loosening.
- [Gap27-5] Currently, the industry only supports fibre cutting detection.

5.11.3 Current related standard specifications

5.11.3.1 ITU-T

The Recommendation ITU-T G.697 [50], published in 2016, primarily addresses optical monitoring for DWDM systems. While the main body of the standard does not provide a detailed description of OTDR in the general technical context of optical monitoring, OTDR serves as a key technology and is one of the important means to achieve the optical monitoring functions outlined in Recommendation ITU-T G.697 [50].

Currently, ITU-T SG15 is defining a standard in Recommendation ITU-T G.681 [i.16] to standardize the architecture and various terms of fibre optic sensing systems.

5.12 3D video enabling via FTTR

5.12.1 Use Case Briefing

As shown in Figure 17, in this use case, FTTR devices (i.e. MFU or SFU), with embedded video processing capability, encode/decode cloud or locally stored 3D content into alternating high-frame-rate formats (e.g. ≥ 120 Hz) for left-and-right-eye views. This transforms a 3D stream into a series of 2D stream. Such 2D video signals are transmitted to high-refresh-rate displays. Moreover, the 3D glasses synchronized with the 2D stream framing provides a real-time left and right eye switch. Therefore, the 3D views can be obtained by the end user. In addition, the 3D video content could be generated via 2D-to-3D transforming process using AI algorithms. See Use Case # 28 in ETSI GR F5G 032 [i.35] for more details.

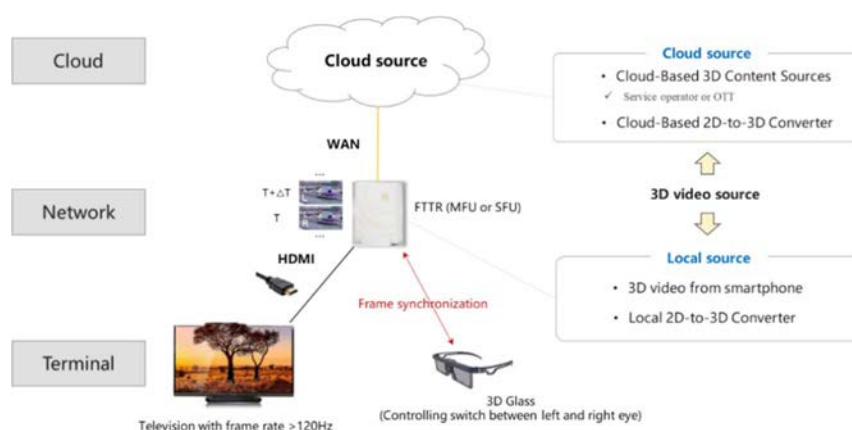

Figure 17: The scenario of 3D video enabling via FTTR

5.12.2 Technology Requirements and Gap Analyses

5.12.2.1 General

Basically, 3D video enabling via FTTR needs on-premises devices collaboration, including 2D-to-3D video real time transforming within FTTR devices, 3D video framing transforming for a traditional 2D display, and the synchronization between FTTR device and display. Moreover, the FTTR network shall provide enough bandwidth to support video streaming, enable stable latency jitter to maintain stable synchronization and provide the management functionality for the whole system.

5.12.2.2 Enable AI assisted 2D-to-3D real-time video transformation

To provide AI assisted functions, the FTTR devices (MFU or SFU) shall include additional computing power such as CPU, NPU, GPU, etc. to support 2D to 3D video transformation. The demand of computing power depends on the video quality (such as resolution, frame rate, etc.). For non-real-time 3D video displaying, the video could be pre-processed and stored in the FTTR devices.

- [R28-1] In the case of local video transformation, the FTTR device shall support computing power to process AI assisted 2D-to-3D video transformation.
- [R28-2] In the case of video transformation in the edge, the connected OLT shall support computing power to process AI assisted 2D-to-3D video transformation.

The current optical access network and on-premises network mainly provides connectivity. With the evolution of AI application, network nodes, including OLT, ONU, RG, etc. needs to implement additional computing module to support running AI training and inferencing. The exact computing power for deployment is scenario oriented and needs to be studied in the near future.

- [Gap28-1] The current FTTR device does not support computing power for AI applications.
- [Gap28-2] The current OLT device does not support computing power for AI applications.

5.12.2.3 Provide accurate synchronization between FTTR devices and 3D glasses

The cooperation between video signals forwarded over FTTR device and the 3D glasses switching is the key to generate a 3D view for end users. Any time delay creates video blurring and degradation, significantly impacting the quality of experience of end users. In general, the reasons of the time delay are caused by many factors, including FTTR device processing capability, network transmission latency, video processing delay, etc. Time delay adjustment methodology needs to be supported for the end user.

- [R28-3] The FTTR devices shall provide accurate synchronization technologies to the 3D glasses.

NOTE: The accuracy requirement of the synchronization depends on the frame rate of the 3D video.

- [R28-4] Left-and-right eye real-time switching shall be supported in the 3D glasses.
- [R28-5] The FTTR devices shall provide time delay adjustment for synchronization alignment.

To achieve the synchronization, an additional module within FTTR device beyond communication is needed. It is recommended to use a wireless methodology in order to facilitate ease of utilization for 3D glasses.

- [Gap28-3] The synchronization between FTTR devices and 3D glass is currently unavailable.
- [Gap28-4] The 3D glasses with left-and-right eye real-time switching is currently unavailable.
- [Gap28-5] The adjustment of the time delay for the synchronization between 3D glass and display is currently unavailable.

5.12.2.4 Provide enough the frame rate for 3D view experience

A 60 Hz frame rate for 3D view provides a fluent viewing perception for humans. This leads to at least 120 Hz 2D video streaming (left and right eye) over the FTTR network. In case of supporting multiple views, additional streams need to be supported. Therefore, the FTTR network is necessary to provide up to 10 Gigabits.

- [R28-6] The FTTR system shall support 10 Gbps throughput.

The current deployed FTTR system could enable symmetric 2.5G data rate (via ITU-T G.709 recommendations). The 10G system standards (i.e. ITU-T G.709 recommendations) are under development in ITU-T. More than 10Gigabit FTTR system needs to be studied in the future.

- [Gap28-6] None.

5.12.2.5 Enable management and control of 3D glasses and FTTR system

Since the cooperation among multiple devices is complex, the system shall provide management and control methods to monitor and configure the whole system. This may include the collection of working status and control for the 3D glasses, and whole system fault detection and warning alarm via the FTTR devices.

- [R28-7] The FTTR system shall provide means to manage and control 3D glasses, including collection of working status, configuration and control.
- [R28-8] The FTTR system shall provide means to monitor the quality of 3D views, detect any faults and forward potential warning to the management platform.

This use case brings additional requirement over management and control since new devices and technology are introduced in this use case. Additional device model and interfaces needs to be developed.

- [Gap28-7] The FTTR system currently does not support the management and control of 3D glasses. The corresponding management and control interface as well as the communication methodology between FTTR devices and 3D glasses is unavailable.
- [Gap28-8] The data model and management entity according to this use case is currently unavailable.

4.12.3 Current related standard specifications

4.12.3.1 ITU-T SG15

The G.Xfin specification are currently under development in the ITU-T Work Items [G.Xfin-PHY](#) [i.50] and [G.Xfin-DLL](#) [i.51].

5.13 Optical cable Co-route detection based on DFOS technology combined with AI capability

5.13.1 Use Case Briefing

Fibre co-routing refers to the scenario in optical networks where different fibre segments are physically located within the same cable or share the same physical pathway (e.g. conduits or trenches). This situation significantly increases operational risks. The primary impact manifests when a single cable with different fibres carrying multiple logical links or primary/backup paths is interrupted due to unexpected events such as construction damage or natural disasters - all fibres within the same cable fail simultaneously. This causes both working and protection paths, designed to ensure service reliability, to be disrupted together, resulting in complete service outage and negating the purpose of high-availability designs.

Furthermore, since data concerning passive optical fibre resources often relies on manual database entries and maintenance, the continuous expansion of optical cable networks leads to frequent delays in updating resource information. This results in inconsistencies between the physical infrastructure and logical network representations in the database. Traditionally, identifying co-routing conditions depends heavily on manual analysis - a process that is not only inefficient but also prone to inaccuracies due to outdated resource data.

However, advanced technologies integrating Distributed Fibre Optic Sensing (DFOS) and Artificial Intelligence (AI) now enable effective management of these co-routing risks. By continuously monitoring parameters such as vibration, strain, and temperature in co-routed fibres, potential failures can be predicted proactively, reducing the probability of large-scale outages. Coupled with GIS-based visual route mapping, operators can optimize fibre layout planning, avoid high-risk co-location in disaster-prone areas, improve resource utilization, and ultimately balance infrastructure efficiency with network resilience. See Use Case # 29 in ETSI GR F5G 032 [i.35] for more details.

5.13.2 Technology Requirements and Gap Analyses

5.13.2.1 General

The current technology primarily relies on manual inspections and static database management, which are inefficient and lack reliability. Manual inspections can only detect 5-6 kilometres of fibre optic cable per day, making it difficult to cover complex environments and prone to errors due to subjective factors. Although traditional OTDR technology can locate faults, it is a post-event detection method and cannot achieve real-time monitoring and risk warning. The static resource database updates are lagging, failing to dynamically reflect changes in network topology, leading to mismatches between physical routes and logical data. These methods lack the ability to continuously monitor environmental parameters, making it impossible to detect risks along the same route in advance, ultimately resulting in high maintenance costs and significantly increased risks of service interruptions.

5.13.2.2 Optical cable Co-route detection performance

AI-driven DFOS technology for Optical cable Co-route detection shall support the following functions and capabilities:

- [R29-1] The detection range should be at least over 140 km to accommodate all span distance scenarios in operators.
- [Gap29-1] Currently, the industry's capabilities can only achieve a range of approximately 80~120km.
- [R29-2] The minimum fibre co-routing length that shall be detectable is less than 100 meters.
- [Gap29-2] Standards which support the minimum fibre co-routing length less than 100 meters are currently unavailable.

In the optical network of carriers, the minimum distance of fibre routing is approximately 100 meters, which serves as the baseline requirement for identifying the fibre routing status.

- [R29-3] The detection accuracy should be at least over 99,9 %, with a minimal proportion of suspected fibre co-routing cases requiring manual verification and confirmation.
- [Gap29-3] Currently, the industry's average detection accuracy is approximately 95 %.
- [R29-4] The Missed Detection Rate (MDR) shall be reduced to zero, meaning no fault events should go unreported.
- [Gap29-4] Currently, the industry's average Missed Detection Rate (MDR) remains around 1 %, indicating that a small portion of fault events still cannot be fully warned in advance.

The MDR refers to the probability that the system fails to detect and trigger an alarm for a true abnormal event. For example, in a DFOS system, an actual intrusion might go undetected, leading to security risks.

Mathematical Expression:

$$MDR = \frac{N_{missed}}{N_{ture}} \times 100 \%$$

Here, N_{missed} is the number of missed detection events, and N_{ture} is the total number of true abnormal events.

- [R29-5] Fibre co-routing status shall be identified online, eliminating the need for manual physical tapping along optical fibre lines for detection.
- [Gap29-5] Currently, an external tapping source is required to determine the co-routing status.
- [R29-6] The routing status of a fibre pair (≥ 80 km at least) shall be determined within 1 hour, while simultaneously achieving automatic GIS-based route visualization and reconstruction.
- [Gap29-6] Currently, the fibre routing status is determined by manual tapping along the optical fibre lines, with a detection rate of only 5-6 km per day, resulting in extremely low efficiency and no GIS automatic reconstruction.
- [R29-7] The optical cable co-route detection shall support co-fibre transmission of service signals and detection signals, enabling integrated sensing and communication (ISAC).

[Gap29-7] Currently, dedicated idle fibres are required for detection purposes.

5.13.3 Current related standard specifications

5.13.3.1 ITU-T

Currently, ITU-T SG15 is defining a standard in Recommendation ITU-T G.681 [i.16] to standardize the architecture and various terms of fibre optic sensing systems.

5.14 Generative AI for F5G-A Network Management Tasks

5.14.1 Use Case Briefing

This use case introduces an on-premise, multi-agent generative-AI co-pilot that turns operator intent into standards-aligned configurations across F5G-A networks. It classifies intent, generates vendor-neutral API client code, validates it against known models, verifies changes in a digital-twin sandbox, and interprets device telemetry in real time reducing OPEX and accelerating delivery while preserving privacy and interoperability. See Use Case # 30 in ETSI GR F5G 032 [i.35] for more details.

5.14.2 Technology Requirements and Gap Analyses

5.14.2.1 General

The integration of generative AI into F5G Advanced network management can reduce operational complexity and enable automation across multi-vendor optical networks. Unlike traditional intent-based approaches, which rely on predefined ontologies, generative AI systems shall dynamically translate operator requests into machine-readable configurations while operating under constraints of limited training data, strict privacy requirements, and the need for standardized, vendor-neutral outputs. To achieve this, several technical requirements shall be satisfied. These requirements are framed around three main domains:

- i) context management and data availability for AI models;
- ii) standardized code generation and validation; and
- iii) operational safety and privacy in deployment.

Each domain faces specific technology and standardization gaps that currently hinder practical implementation of generative AI in F5G-A optical networks.

5.14.2.2 Context Management and Data Availability

Generative AI models cannot ingest all possible device models and configuration examples at once due to token limitations, and operators face restricted access to vendor data. Effective solutions therefore require mechanisms to retrieve and provide only the most relevant context to the model on demand. So also, proprietary vendor specific configuration data is needed to perform the right AI decisions, therefore particular mechanisms are needed to provide some information in a confidentiality preserving way to the generative AI system.

- [R30-1] The generative AI system shall support selective retrieval and dynamic context management, enabling only the most relevant data models, templates, or configuration examples to be provided to the Large Language Model (LLM).
- [R30-2] The generative AI system shall support the use of vendor-specific configuration data, without violating confidentiality.
- [Gap30-1] No standardized framework exists for integrating generative AI with network model repositories (YANG, OpenConfig, vendor extensions) in a scalable way.
- [Gap30-2] Mechanisms for federated or privacy-preserving access to vendor data are not currently defined, making realistic, multi-vendor AI training and operation difficult.

5.14.2.3 Code Generation and Validation

Once context is supplied, the generative AI shall generate outputs that align with standardized management interfaces. Without strict validation, there is a risk of syntax errors, vendor lock-in, or unsafe deployments.

- [R30-3] The generative AI system shall generate vendor-neutral configurations aligned with standard data models and management protocols.
- EXAMPLE: Standard data models like YANG, OpenConfig, and Management protocols like NETCONF and RESTCONF.
- [R30-4] The system shall perform automated validation of generated code against schema rules and provide a safe environment for pre-deployment verification.
- [Gap30-3] No standardized closed-loop pipeline exists to connect AI output with schema validators and pre-deployment testing; current approaches remain ad-hoc.
- [Gap30-4] Some AI solutions continue to generate proprietary configuration outputs without standardized validation, preventing interoperability in multi-vendor networks.

5.14.2.4 Operational Safety and Privacy

Telecom networks are highly sensitive environments where misconfigurations may cause service disruption. Generative AI shall be deployed in ways that guarantee compliance, traceability, and operator oversight.

- [R30-5] The generative AI system shall be deployable on-premise within operator infrastructure, ensuring compliance with NDA and data privacy obligations.
- [R30-6] The system shall provide a sandbox or digital twin environment where AI-generated configurations can be tested safely before deployment to live devices.
- [Gap30-5] No standard deployment guidelines exist for LLMs in telco-grade environments, including compute, redundancy, and OSS/NMS integration.
- [Gap30-6] While digital twin frameworks for networks exist, they are not designed to interface with generative AI agents or provide a standardized API for validation of AI-generated configurations.

5.14.3 Current related standard specifications

5.14.3.1 OpenConfig

Vendor-neutral YANG models for common network elements and services for streaming telemetry and configurations. Relevance: Primary target for code generation ([R30-3]) and schema-based validation ([R30-4]).

5.14.3.2 ETSI ISG F5G - Telemetry Framework and Requirements for Access Networks

Defines the components of a telemetry platform, including data collection, control functions, storage, and access interfaces. Relevance: Establishes how telemetry should be collected and managed in F5G-A networks. This provides the reference architecture for integrating generative AI agents into the telemetry pipeline, ensuring safe, standardized access to network state ([R30-1], [R30-6]).

5.15 Distributed Intelligence with Privacy-Preserving Features for FTTR

5.15.1 Use Case Briefing

The Fibre-To-The-Room (FTTR) solution marks the next evolution in delivering ultra-high-speed connectivity for residential and enterprise settings by extending optical fibre links directly into each individual room. Conventional centralized network architectures face difficulties in fulfilling the rising requirements for adaptive Quality of Service (QoS), energy efficiency, and real-time network intelligence. Incorporating Distributed Intelligence (DI) into FTTR deployments aims to overcome these issues and constraints by embedding computing capabilities across multiple network elements, thus decentralizing network intelligence throughout the optical access domain. This use case highlights a DI-enabled FTTR framework that distributes intelligent functions among the Sub FTTR Units (SFU), Main FTTR Unit (MFU), Optical Line Terminal (OLT) and the Edge Cloud, while optimizing power consumption and QoS at the subscriber end, ensuring improved service quality, privacy protection, reduced and adaptable power consumption, and greater customer satisfaction. See Use Case # 31 in ETSI GR F5G 032 [i.35] for more details.

5.15.2 Technology Requirements and Gap Analyses

5.15.2.1 General

The FTTR network architectures rely on multiple network elements, including an Optical Line Terminal (OLT) with access to the Edge Cloud at the Operator premises, a Main FTTR Unit (MFU) and Sub FTTR Units (SFUs) within the client premises. To enable next-generation, intelligent services - high-bandwidth applications, real-time analytics, and energy-aware operations - FTTR components need to evolve beyond basic connectivity to incorporate advanced computing, telemetry, and privacy mechanisms. The following sections present some of the most critical technology requirements to enable distributed intelligence, with the associated gaps that shall be bridged in future standards and developments. An important technology which facilitates the DI for FTTR is computing collaboration, presented in more detail in the Use Case #3 on Computing Collaboration in PON network in ETSI GR F5G 020 [i.1].

5.15.2.2 Heterogeneous computing capability

To facilitate the distributed intelligence function in the network elements for diverse service and dynamic computing, additional computing capability is required. Dedicated computing hardware including CPU/GPU/NPU shall be integrated at the system level, such as the OLT, the MFU and the SFU. As such, independent computing-oriented software or applications can be run without affecting the normal data transmission service. Additional computing-oriented hardware or modules need to be supported in the FTTR network elements to offer computing functions and collaboration.

- [R31-1] FTTR networks shall support heterogeneous computing across OLT, MFU, and SFU modules to host distributed intelligence functions and AI workloads.
- [R31-2] Onboard computing hardware shall be integrated in the FTTR network elements, since it is essential for real-time decision making at the network edge.
- [R31-3] These processing components shall ensure low-latency processing of telemetry data and support advanced analytics applications including service recognition, anomaly detection and dynamic bandwidth optimization.
- [Gap31-1] Current FTTR hardware is optimized primarily for packet forwarding and basic control-plane tasks, lacking the computational capabilities required for AI-driven operations.
- [Gap31-2] Most MFU and SFU devices contain only minimal processors for management and graphical interfaces (GUIs), lacking any internal hardware required for processing of AI workloads.
- [Gap31-3] Standards defining clear performance baselines/benchmarks and hardware extensibility requirements are missing, which are essential to ensure future network elements can integrate heterogeneous computing resources.

5.15.2.3 Identification of Service Flow Type and Demand for Dynamic QoS

The FTTR network elements shall be capable of identifying the service flow types and understand their corresponding requirements. This can be done by the FTTR network elements themselves or managed by an external computing entity such as the Edge cloud platform on the operator side. The FTTR shall also identify the corresponding QoS requirements, including throughput, latency, and packet jitter.

- [R31-4] The network shall automatically classify service flows and map them to their corresponding Quality of Service (QoS) requirements.
- [R31-5] Real-time identification shall enable dynamic bandwidth allocation and prioritization, ensuring consistent user experience across diverse applications.
- [Gap31-4] Present FTTR solutions treat traffic largely as undifferentiated IP flows, relying on static QoS profiles, limiting the responsiveness to sudden changes in service demand or application mix.
- [Gap31-5] There is currently no standardized method for per-flow service classification or feedback between SFU/MFU and OLT to adjust QoS parameters dynamically.

5.15.2.4 Dynamic Telemetry Data Streaming from SFUs and MFU

Optical FTTR networks require enhanced telemetry and data streaming capabilities across SFU, MFU, and OLT devices to enable distributed intelligence, predictive maintenance, and AI-driven analytics. However, current in-home devices (i.e. MFU and SFU) lack standardized telemetry support and secure streaming protocols, creating a gap that shall be addressed by defining data models, APIs, and lightweight encryption mechanisms for privacy and sensitive data.

- [R31-6] SFU and MFU devices shall generate and stream fine-grained telemetry data - mirroring the OLT capabilities - to enable data-driven operations and analytics at the end-user location.
- [R31-7] Telemetry data shall be accessible via secure APIs for integration with AI algorithms and pipelines, to facilitate predictive maintenance and real-time traffic and service analytics, which are critical capabilities for distributed intelligence, where decisions are made at multiple network layers.
- [R31-8] Telemetry data models and high-frequency, low-latency telemetry streaming protocols, exposing traffic counters, optical power levels, QoE metrics, shall be defined for SFU and MFU nodes, for them to stream anonymously these metrics to OLT and Edge Cloud for AI training and inference.
- [Gap31-6] Currently, SFU and MFU hardware typically expose only a GUI-based interface aimed at end users, with no native telemetry streaming, or basic SNMP or CLI capabilities.
- [Gap31-7] Operators and potential AI applications currently lack direct access to granular performance data from in-home ONUs.
- [Gap31-8] Current standards do not define telemetry data models, streaming protocols, and security mechanisms for the SFU and MFU nodes, such as gNMI or telemetry streaming with lightweight encryption for end-user privacy preservation.

5.15.2.5 Power Consumption Metrics as KPI for Green ICT Enabling

With ONUs accounting for almost 90% of the total PON power consumption, FTTR networks will increasingly require real-time power consumption metrics from SFU and MFU units to enable green ICT practices such as dynamic power control, energy optimization, and automated reporting. Yet current hardware lacks built-in energy metering and standardized reporting, creating a gap to be filled through standardized requirements for integrated sensors and unified data formats to enable industry-wide adoption of energy-aware solutions.

- [R31-9] To support sustainable network operations, SFU and MFU units shall provide accurate, real-time metrics on their power consumption, to allow green ICT policies for dynamic power control and optimization, as well as automated energy reporting.

- [Gap31-9] Current FTTR hardware does not include sensors or interfaces to report live power consumption (typically, solely the operation voltage (V)), making it challenging to track energy efficiency or implement adaptive power-management strategies at the device level.

5.15.2.6 AI Model Orchestration and Management

FTTR systems shall support standardized mechanisms for deploying, updating, and retiring ML models across Edge Cloud, OLT, MFU, and SFU nodes, including version control and rollback. Today's network management systems lack such capabilities, with no defined APIs linking network controllers to MLOps pipelines, highlighting the need for new standards to enable distributed AI lifecycle management.

- [R31-10] Mechanisms to deploy, update, and retire ML models shall be supported and standardized across Edge Cloud, OLT, MFU, and SFU nodes with version control and rollback.
- [Gap31-10] Current network management systems are not designed for ML model distribution or federated learning, with no standard APIs between network controllers and MLOps pipelines being currently defined or existing.

5.15.2.7 Privacy and GDPR Compliance

FTTR deployments in Europe shall ensure that telemetry and service-related data from SFU and MFU units comply with GDPR, requiring privacy-preserving mechanisms such as anonymization, local processing, and strict access controls. However, current systems lack standardized methods for anonymization and data restriction, making new specifications essential to embed privacy-by-design principles and GDPR compliance into future FTTR solutions.

- [R31-11] All telemetry and service-related data collected from SFU and MFU units within European deployments shall comply with the General Data Protection Regulation (GDPR), such that sensitive end-user information shall be anonymized or kept entirely local to prevent disclosure to the network operator.
- [R31-12] FTTR telemetry streaming standards shall mandate privacy-preserving data collection and define strict access control policies.
- [Gap31-11] Currently, there is no uniform standard for anonymization or for restricting the export of sensitive data from FTTR customer premises.
- [Gap31-12] With the lacking FTTR telemetry streaming standards, there are also no related specifications concerning privacy-by-design principles for telemetry data, including encryption, local processing of personally identifiable information, and user consent mechanisms to meet GDPR requirements.

5.15.2.8 Interoperability and Standardization Across Vendors

Future FTTR systems shall also ensure multi-vendor interoperability for AI-related telemetry data, control API interfaces, and model execution environments to support open, scalable deployments. Current FTTR specifications lack standardized YANG models or container runtimes, leading to proprietary solutions that risk vendor lock-in and limit ecosystem growth.

- [R31-13] Multi-vendor interoperability for AI telemetry formats, control APIs, and model execution environments shall be designed and standardized.
- [Gap31-13] Current FTTR specifications do not define AI-related YANG models or container runtimes.

5.15.3 Current related standard specifications

5.15.3.1 ITU-T

ITU-T SG15 defines interfaces for PON and FTTR networks:

- 1) Between the OLT and the MFU based on OMCI [10].
- 2) Between the MFU and the SFU based on FMCI [i.11].

ITU-T SG15 Q2 defined the Optical Management & Control Interface (OMCI) [10] for MFU management by the OLT. This interface is a layer 2 management interface, having higher transmission priority in an independent logic channel.

ITU-T SG15 Q3 defined the Fibre Management & Control Interface (FMCI [i.11]) and WLAN Management & Control Interface (WMCI [i.12]) to exchange management or control information for the fibre link and the Wi-Fi® link.

5.15.3.2 ETSI

Some of the technology requirements and gap analyses presented for this use case of distributed intelligence for FTTR are also related to the technology requirements and gap analyses of use-case on Computing collaboration in PON network presented in ETSI GS F5G 023 [i.48].

Some of the main requirements towards the FTTR deployments in home area networks, apartment buildings, dense residential areas, and small-medium enterprises (SME) are presented and listed in the ETSI GR F5G 008 [i.46], with the corresponding gap analyses conducted in ETSI GS F5G 013 [11], where similarly to the distributed intelligence for FTTR use-case, power saving and management capabilities are discussed.

Relatable and applicable telemetry data models, protocols and APIs for telemetry data streaming in the distributed FTTR units are presented and analysed in detail in ETSI GS F5G 016 [i.49], with the F5G telemetry framework and requirements showcased and discussed in ETSI GS F5G 011 [i.31].

Applicable Key Quality Indicators (KQI) with their corresponding data models, interfaces and protocols for network and service monitoring in FTTR are thoroughly presented and analysed in ETSI GS F5G 026 [23].

6 Technology Landscape Summary

Table 2 is a collection of requirements and gaps addressed in clause 4 and 5 of the present document, and organized per use cases.

In case there is no gap for a certain requirement, the gap is "None". In case multiple requirements are mapped to one gap, the following numbered gap is marked as "Same as [GapUC#-yy]", where UC# represents the use case number and yy represents the gap number within that use case. The same is true for requirement numbering [RUC#-xx] where UC# represents the use case number and xx represents the requirement number within that use case.

Table 2: Summary of Requirements and Gaps

Technology requirements	Gaps
UC#1: Premium private line service automation	
[R1-1]: The OTN electrical and optical layer resource information shall be reported to the premium private line service provisioning system in real-time.	[Gap1-1]: Real-time resource discovery of fgOTN resources is currently not supported.
[R1-2]: Computing and creating of both the OTN electrical and the optical layer paths shall be supported for private line service.	[Gap1-2]: Standardized YANG data models for computing and creating both the OTN electrical and optical layer paths for private line service are currently not supported.
[R1-3]: The network management and control system should support automatic discovery and automatic configuration of the OTN CPEs.	[Gap1-3]: OTN CPE plug-and-play is currently not supported.
[R1-4]: The OTN shall support hitless bandwidth adjustment of an OTN connection.	[Gap1-4]: None.
[R1-5]: The OTN shall support instant bandwidth adjustment of an OTN connection.	[Gap1-5]: Standardized YANG data models for bandwidth adjustment of an fgOTN connection is currently not supported.
[R1-6]: The premium private line service provisioning system shall support SLA information query and alarm report APIs.	[Gap1-6]: Standardized APIs and YANG data models for SLA information query and alarm report are currently not supported.
UC#2: Stable & reliable Wi-Fi® connection over on-premises networking	
[R2-1]: The fibre-based on-premises network shall support network application identification and the corresponding QoS mechanisms.	[Gap2-1]: None.
[R2-2]: The fibre-based on-premises network shall support an on-premises network centralized controller.	[Gap2-2]: None.
[R2-3]: The fibre-based on-premises network shall support real time Wi-Fi® channel information collection.	[Gap2-3]: None.

[R2-4]: The fibre-based on-premises network shall support continuous real time Wi-Fi® transmission behaviour configuration of each Wi-Fi® AP.	[Gap2-4]: None.
[R2-5]: The fibre-based on-premises network shall support a low latency control channel with a 64 µs round trip time between the M-FTR and the S-FTR.	[Gap2-5]: None.
[R2-6]: The fibre-based on-premises network shall support a control messaging procedure with bounded latency as required by the identified QoS.	[Gap2-6]: None.
[R2-7]: The fibre-based on-premises network shall provide a reliable handover message transmission channel with deterministic latency.	[Gap2-7]: None.
UC#3: Computing collaboration in PON network	
[R3-1]: The PON network elements shall support additional computing-oriented hardware or modules.	[Gap3-1]: Additional computing-oriented hardware or modules in the current PON network elements, including the OLT, the P-ONU and the E-ONU are currently not available.
[R3-2]: The PON network shall support service flow identification and identification of the corresponding QoS requirements.	[Gap3-2]: A dynamic and quantitative QoS indication scheme for practical data flows for the PON network are currently not available.
[R3-3]: The cloud platform shall support the enabling or disabling computing collaboration of the OLT, the P-ONU or the E-ONU.	[Gap3-3]: A Collaboration function is not defined in the current E2E system.
[R3-4]: The cloud platform shall be capable of collecting the computing capability information and utilization of the OLT, the P-ONU or the E-ONU computing resources.	[Gap3-4]: A Data model for computing collaboration is currently not available in BBF TR-069 [i.14] and BBF TR-369 [i.15].
[R3-5]: The OLT shall support a computing collaboration information and configuration exchange interface with the P-ONU and the E-ONU.	[Gap3-5]: A Data model for computing collaboration is currently not available in OMCI [10].
[R3-6]: The on-premises network P-ONU shall support a computing information and configuration exchange interface with the E-ONU.	[Gap3-6]: A Data model for computing collaboration is currently not available in FMCI [i.11] or WMCI [i.12] for the on-premises network.
UC#4: Intelligent power grid	
[R4-1]: The DCI network of the intelligent power grid shall support up to 800 Gbps per wavelength up to 80 km.	[Gap4-1]: None.
[R4-2]: The backbone transport network of the intelligent power grid shall support ultra-large State Of Polarization (SOP) with at least 8 M rad/s.	[Gap4-2]: None.
[R4-3]: The backbone transport network of the intelligent power grid shall support ultra-long single-span of at least 500 km.	[Gap4-3]: Ultra-long single-span with at least 500 km distance technology is currently unavailable Ultra-long single-span with at least 500 km technology is currently unavailable.
[R4-4]: The backbone transport network of the intelligent power grid shall support ultra-long single-span of at least 500 km.	[Gap4-4]: None.
[R4-5]: The substation transport network of the intelligent power grid shall support fine granularity with 10 Mbps tributary slots.	[Gap4-5]: None.
[R4-6]: The substation transport network of the intelligent power grid shall support hard isolation, low latency, low latency variation, Operation, Administration and Maintenance (OAM).	[Gap4-6]: None.
[R4-7]: F5G Advanced network of the intelligent power grid should support migration of legacy SDH network.	[Gap4-7]: None.
[R4-8]: The substation transport network of the intelligent power grid shall support timing transparent transmission for CBR services.	[Gap4-8]: None.
[R4-9]: The substation transport network of the intelligent power grid shall support agile and hitless bandwidth adjustment capabilities.	[Gap4-9]: None.
[R4-10]: The communication network of the intelligent power grid shall support an end-to-end high quality hard isolated connection.	[Gap4-10]: None.
[R4-11]: The communication network of the intelligent power grid shall support a multi-level flexible scheduling mechanism at the wavelength, ODU as channel, and fgOTN as service levels.	[Gap4-11]: None.

UC#5: Railway perimeter inspection	
[R5-1]: Unidirectional coverage range shall be greater than 50 km.	[Gap5-1]: Standards which support unidirectional coverage range greater than 50 km are currently unavailable.
[R5-2]: The detection rate of true intrusion events shall be greater than 99,9 %.	[Gap5-2]: Standards which support the detection rate greater than 99,9 % are currently unavailable.
[R5-3]: The frequency of false intrusion events shall be less than 0,002 events/km/hour on average.	[Gap5-3]: Standards which support the frequency of false intrusion events less than 0,002 events/km/hour on average are currently unavailable.
[R5-4]: The position accuracy of the true intrusion event detection shall be less than 10 m.	[Gap5-4]: Standards which support the position accuracy less than 10 m are currently unavailable.
[R5-5]: Intrusion event identification time shall be less than 5 s.	[Gap5-5]: Standards which support intrusion event identification time less than 5 s are currently unavailable.
UC#6: Naked-eye 3D display	
[R6-1]: The F5G-A access network shall provide symmetric 10 Gbps data rate for each subscriber.	[Gap6-1]: None.
[R6-2]: The FTTR on-premises network shall provide symmetric 10 Gbps data rate.	[Gap6-2]: None.
[R6-3]: The E2E F5G-A network shall support < 10 ms RTT.	[Gap6-3]: The unified E2E latency control is not specified yet. E2E coordination mechanism is still currently not available.
UC#7: Unified access and on-premises network	
[R7-1]: The OLT shall be capable of requesting and receiving transmission status (including data buffer, communication environment) from any device in the F5G-A access network and on-premises network, including the P-ONU and the E-ONU	[Gap7-1]: The OLT direct collection of the E-ONU's transmission status is currently not available.
[R7-2]: The OLT shall be capable of configuring the transmission behaviour of any device in the F5G-A access network and the on-premises network.	[Gap7-2]: The OLT support for the direct configuration of each E-ONU is currently not available.
[R7-3]: The P-ONUs shall be capable of providing local control for the E-ONUs and the corresponding end user devices through a centralized control mechanism.	[Gap7-3]: None.
[R7-4]: The F5G-A optical access network and the on-premises network shall support an extension of the OMCI management interface.	[Gap7-4]: The extended OMCI management interface to enable global management of any device in the F5G-A access network and the on-premises network is currently not supported by the OLT.
[R7-5]: The unified management system shall support the management coordination between OLT and P-ONUs.	[Gap7-5]: The unified management system between the OLT, the P-ONUs and E-ONUs is currently not supported.
[R7-6]: The unified management system shall support a single management protocol for both the F5G-A access network devices and the on-premises network devices.	[Gap7-6]: The protocol for device information collection based on a single protocol is currently not available.
[R7-7]: The unified management shall support the collection of device information from the different network elements once they are connected by optical fibre.	[Gap7-7]: The direct collection of device information for both the P-ONU and E-ONUs is currently not supported.
[R7-8]: The unified management shall provide visualization of the logical links for the different service flows.	[Gap7-8]: The management system providing visualization of the logical link for the different service flows via the OLT OMCI is currently not supported.
UC#8: OTN intelligent fault management	
[R8-1]: The intelligent OTN fault management system shall support collecting alarm information from the OTN NEs.	[Gap8-1]: None.
[R8-2]: The intelligent OTN fault management system shall support root alarm identification from the received alarms.	[Gap8-2]: Root alarm identification from the aggregated alarm reporting is currently not supported.
[R8-3]: The intelligent OTN fault management system shall support OTN root cause analysis based on a set of correlated alarms.	[Gap8-3]: OTN root cause analysis is currently not supported.
[R8-4]: The intelligent OTN fault management system should support providing fault repair recommendations.	[Gap8-4]: The provisioning of OTN fault repair recommendations is currently not supported.
[R8-5]: The intelligent OTN fault management system shall support fault impact analysis.	[Gap8-5]: OTN fault impact analysis is currently not supported.
[R8-6]: The intelligent OTN fault management system should support providing fault handling priorities.	[Gap8-6]: The provisioning of OTN fault handling priorities is currently not supported.
[R8-7]: The intelligent OTN fault management system shall support reporting the identified incident information.	[Gap8-7]: The information report of an identified incident is currently not supported.
[R8-8]: The reported incident information shall support at least the elements listed in clause 4.9.2.5.	[Gap8-8]: The YANG models for the information report of an identified incident are currently not supported.

UC#9: Evaluation and assurance of user service experience	
[R9-1]: The user experience evaluation model shall be defined.	[Gap9-1]: None.
[R9-2]: The F5G-A Access Network QoE analysis system shall collect the F5G-A Access Network service and network KQIs.	[Gap9-2]: The interface to obtain the F5G-A Access Network service and the network KQIs is currently not supported.
[R9-3]: A portal to the F5G-A Access Network QoE analysis system should be provided to report the location and the key factors affecting the users' service experience.	[Gap9-3]: The F5G-A Access Network QoE analysis system interface that provides the location and the key factors that affect the user's service experience to the management and control system is currently not supported.
[R9-4]: A portal to the F5G-A Access Network QoE analysis system should be provided to report the users who are considered to have, or potentially will have service experience problems.	[Gap9-4]: The F5G-A Access Network QoE analysis system interface that provides the list of users who are considered to have, or will potentially have service experience problems to the management and control system is currently not supported.
[R9-5]: The F5G-A Access Network QoE analysis system shall support automatic reconfiguration of the Access Network element(s) to resolve software problems that cause service experience problems.	[Gap9-5]: The automatic reconfiguration of the F5G-A Access Network to resolve software problems that cause service experience problems is currently not supported.
[R9-6]: The F5G-A Access Network QoE analysis system shall support dispatching the user service experience problem trouble tickets.	[Gap9-6]: The trouble ticket or maintenance ticket dispatching, when a user's QoE problem or potential problem are detected by the F5G-A Access Network QoE analysis system, is currently not supported.
UC#10: Cloud Desktop	
[R10-1]: The Edge cloud infrastructure shall be deployed close to the end user to support low latency of data transmission in a F5G-A network.	[Gap10-1]: None.
[R10-2]: The Edge cloud should support coordination with remote cloud to enable the best service QoS for the end user.	[Gap10-2]: The computing coordination mechanism between different F5G-A network elements is not currently available.
[R10-3]: The F5G-A network shall support cloud desktop service identification and support the assignment of service priority.	[Gap10-3]: The F5G-A network adaptation mechanism to the variation of network demand due to the cloud desktop service is currently not available.
[R10-4]: The F5G-A network shall support slicing technology and guaranteeing network QoS for cloud desktop service delivery.	[Gap10-4]: None.
[R10-5]: Shallow compression technique with low compression ratio shall be supported by Cloud desktop technology.	[Gap10-5]: Shallow compression techniques with a low compression ratio is currently not available.
[R10-6]: Independent encoding and decoding process in shallow compressing for each frame shall be supported by Cloud desktop technology.	[Gap10-6]: Independent encoding & decoding for each data frame is currently not available.
[R10-7]: The F5G-A system shall support parallel compression for cloud desktop service slices.	[Gap10-7]: Parallel compression for cloud desktop service slices is currently not available.
UC#11: Dynamically digitalized ODN	
[R11-1]: The digitalized ODN system shall support dynamic visualization of the ODN topology between the OLT and the ONU or P-ONU.	[Gap11-1]: The dynamic visualization of the ODN topology is currently not available.
[R11-2]: The digitalized ODN system shall support GIS-based location identification and visualization of the ODN.	[Gap11-2]: The physical location of the ODN is currently not available.
[R11-3]: The digitalized ODN system shall support the dynamic visualization of insertion loss for the different ODN segments.	[Gap11-3]: The dynamic collection of the ODN insertion loss is currently not available.
[R11-4]: The digitalized ODN system shall support proactive optical path diagnostics.	[Gap11-4]: Proactive diagnostic and recovery of ODN faults are currently not available.
[R11-5]: The digitalized ODN system shall support remote fault locating within 15 minutes.	[Gap11-5]: Dynamic remote fault location determination is currently not available.
[R11-6]: The digitalized ODN system shall support ODN resource status collection.	[Gap11-6]: ODN resource management is currently not available.
UC#12: On-premises Millimetre-Wave (mmWave) WLAN	
[R12-1]: The mmWave Wi-Fi® shall support 10 Gbps throughput on the air interface in the unlicensed V-band and Q-band.	[Gap12-1]: The sub-6 GHz alignments with mmWave Wi-Fi® technology is currently not available.
[R12-2]: The mmWave Wi-Fi® shall support a coordinated transmission mechanism to avoid packet collision in the air interface (i.e. within a single BSSID).	[Gap12-2]: The coordinated transmission mechanism supporting the new 6 GHz aligned system specification, is currently unavailable.

[R12-3]: The mmWave Wi-Fi® over the FTTR system shall be capable of sensing the signal distribution of each AP and control the transmission power to mitigate interference between rooms.	[Gap12-3]: The data model for Wi-Fi® devices is currently unavailable.
[R12-4]: The mmWave Wi-Fi® over FTTR system shall provide a coordination scheme with sub-6 GHz Wi-Fi® to maintain the quality of connection during link switching within a single AP and link switching between different APs.	[Gap12-4]: The coordination mechanism between sub-6 GHz and mmWave Wi-Fi® for link switching is currently not available.
[R12-5]: The sub-6 GHz Wi-Fi® should support the mmWave Wi-Fi® by assisting with beamforming, beam tracking and link adaptation.	[Gap12-5]: The assistance mechanism of sub-6 GHz Wi-Fi® for mmWave Wi-Fi® for beamforming, beam tracking and link adaptation is currently not available.
[R12-6]: The sub-6 GHz Wi-Fi® should support mmWave Wi-Fi® link control information transport.	[Gap12-6]: The separated control and data plane for mmWave Wi-Fi® through sub-6 GHz Wi-Fi® is currently not available.
UC#13: Wavelength-shared WDM aggregation network (AGGN)	
[R13-1]: The wavelength-shared WDM AGGN shall support the smooth evolution to higher data rate beyond 200 G per channel.	[Gap13-1]: None.
[R13-2]: The wavelength-shared WDM AGGN shall support efficient utilization of wavelength resources.	[Gap13-2]: Standard for wavelength sharing between different rings in wavelength-shared WDM AGGN is currently not defined.
[R13-3]: The wavelength-shared WDM AGGN shall support a multiple-ring multi-service access network structure with the reuse of wavelengths per AGGN node.	[Gap13-3]: The multiple-ring multi-service access network structure standard is currently not supported.
[R13-4]: The wavelength-shared WDM AGGN shall support an all optical transparent connection up to 320 km.	[Gap13-4]: None.
[R13-5]: The wavelength-shared WDM AGGN should support optical-layer wavelength grooming.	[Gap13-5]: Standard for function model of integrated ROADM with higher integration, smaller size, lower power, is currently not defined.
[R13-6]: The wavelength-shared WDM AGGN should support dynamic allocation of bandwidth granularity.	[Gap13-6]: None.
[R13-7]: The wavelength-shared WDM AGGN shall support real-time monitoring of single channel and transmission link.	[Gap13-7]: A performance monitoring standard for wavelength-shared WDM AGGN is currently not defined.
[R13-8]: The wavelength-shared WDM AGGN shall support automatic allocation of wavelength resources and network optimization.	[Gap13-8]: An automatic network O&M standard for wavelength-shared WDM AGGN is currently not defined.
UC#14: Robotics as a Service	
[R14-1]: The F5G-A network used in robotic system shall support latency of less than 1 ms for the acceptable milling application.	[Gap14-1]: None.
[R14-2]: The F5G-A network used in robotic system shall support latency of 0,25 ms for the ideal milling application.	[Gap14-2]: The latency for the ideal milling application is not currently achievable.
[R14-3]: The F5G-A network used in robotic system shall guarantee a maximum latency of 5 ms for an acceptable safety application.	[Gap14-3]: None.
[R14-4]: The F5G-A network used in robotic system shall have a latency of 0,5 ms for the ideal safety application.	[Gap14-4]: The ideal latency for safety application is 0,5 ms not currently achievable.
[R14-5]: Cables utilized in RaaS shall be capable of withstanding a minimum of $\pm 90^\circ$ twist per meter for acceptable cable twisting.	[Gap14-5]: None.
[R14-6]: The cable bend shall be 10 times the outer diameter of the cable for acceptable cable bending.	[Gap14-6]: None.
[R14-7]: Cables utilized in RaaS shall be capable of withstanding a minimum of $\pm 180^\circ$ twist per meter for ideal twisting.	[Gap14-7]: The ideal cable requirements of $\pm 180^\circ$ twist per meter which is not currently supported.
[R14-8]: The cable bend shall be 12,5 times the outer diameter of the cable for ideal bending.	[Gap14-8]: The ideal bend is 12,5 times the outer diameters not currently supported.
[R14-9]: The F5G-A network communication system shall be designed to allow a robotics expert to complete the installation and configuration without prior knowledge of F5G-A technology.	[Gap14-9]: Simplified installation and configuration of enterprise network communication for RaaS applications effectively is currently not supported and still need for specialized knowledge or training in F5G-A technology.
[R14-10]: The F5G-A network communication system should support the Data Distribution Service (DDS), when the Robotics Operating System (ROS) is using the DDS communication service.	[Gap14-10]: The mapping of the DDS over the F5G-A network architecture is currently not standardized.

UC#15: All-optical base for urban rail transit communication network	
[R15-1]: The railway line-network transmission network for the urban rail transit network shall support the smooth evolution to 800 Gbps per wavelength.	[Gap15-1]: None.
[R15-2]: The railway line transmission network for the urban rail transit network shall support a modular configuration of both grey light and coloured light.	[Gap15-2]: None.
[R15-3]: The railway station access network for the urban rail transit network shall support up to 50 Gbps and co-existence with multiple PON generations.	[Gap15-3]: None.
[R15-4]: The F5G Advanced network of the urban rail transit network shall support hard isolation.	[Gap15-4]: None.
[R15-5]: The F5G Advanced network of the urban rail transit network shall support efficient bandwidth utilization.	[Gap15-5]: None.
[R15-6]: The F5G Advanced network of the urban rail transit network shall support low latency, low latency variation, Operation, Administration and Maintenance (OAM).	[Gap15-6]: None.
[R15-7]: The F5G Advanced network of the urban rail transit network shall support 99,9999 % reliability.	[Gap15-7]: None.
UC#16: Optical Fibre Sensing for telecom operators	
[R16-1]: The vibration waveform detection distance shall be greater than 80 km per fibre sensing node device.	[Gap16-1]: Standards enabling vibration waveform detection distance greater than 80 km are currently not available.
[R16-2]: False negative and false positive rate shall not exceed 1 %.	[Gap16-2]: Standards which support ≤ 1 % false negative and false positive rate are not currently available.
[R16-3]: The vibration waveform detection accuracy shall be at least 95 %.	[Gap16-3]: Standards supporting vibration waveform identification with an accuracy of at least 95 % are currently not available.
[R16-4]: The detected event location accuracy shall be ≤ 10 m.	[Gap16-4]: Standards supporting event location accuracy of ≤ 10 m are currently not available.
[R16-5]: The fibre sensing system shall support fast learning of fibre fault detection and self-improving.	[Gap16-5]: Standards for fibre sensing system which supporting fast learning and self-improving are currently not available.
[R16-6]: The fibre sensing system shall support continuous real time monitoring.	[Gap16-6]: Standards which support a real-time monitoring capability are currently not available.
[R16-7]: The Telecom operator network management system in cooperation with GIS shall be capable to link the detected events to geographic locations.	[Gap16-7]: None.
[R16-8]: The fibre sensing system definition of the optical interface, the electronic interface and the management & control interface should be standardized.	[Gap16-8]: Standards which define the fibre sensing system architecture, the optical interface, the electronic interface and the management & control, and enabling communication hardware reuse or supply chain reuse, are currently not available.
UC#17: QoD App-Flow service provisioning	
[R17-1]: The F5G-A network shall support Quality on Demand APIs.	[Gap17-1]: QoD API standards for fixed networks is currently unavailable.
[R17-2]: The F5G-A network shall support the provisioning of different App-Flow services with different QoS requirements.	[Gap17-2]: A standard for the provisioning of App-Flow services with different QoS requirements is currently unavailable.
[R17-3]: The F5G-A network shall support SLA management.	[Gap17-3]: SLA management for fine granular application flows is currently unavailable.
[R17-4]: The F5G-A network shall support application flow granularity QoS management mechanisms in both the CPN and the Access Network.	[Gap17-4]: The standard for fine granular application flow QoS management mechanisms with very low reaction time is currently unavailable.
[R17-5]: The F5G-A network shall support a real-time QoS control subsystem in the CPN and in both the Access Network.	[Gap17-5]: The real-time QoS control and adaptation to application changes is not currently available.
[R17-6]: The F5G-A network shall support the identification of fine granular application flows through the QoD API.	[Gap17-6]: For the identification of application flows through an API interaction, is currently not available.
[R17-7]: The F5G-A network shall support the identification of application flows automatically.	[Gap17-7]: The standard for the automatic identification of application flows, is currently not available.
[R17-8]: The F5G-A network shall support the mapping of fine granular application flows to the underlying QoS guaranteed connections.	[Gap17-8]: The mapping of fine granular application flows to the QoS guaranteed connections is currently not available.
[R17-9]: The F5G-A network shall support telemetry for a very large number of application flows.	[Gap17-9]: Standards for telemetry on a large scale is currently not available.

[R17-10]: The F5G-A network shall support ONUs with computing-enhanced ONU/FTTR functionality.	[Gap17-10]: Standards for support of ONUs with compute functionality is currently not available.
[R17-11]: The F5G-A network shall support cooperation of compute functionality located in the access and the customer premises network equipment.	[Gap17-11]: Standards for cooperation of compute located on different Access Network and CPN equipment is currently not available.
UC#18: Smart Hospital	
[R18-1]: OLT should be scalable to support multiple current widely deployed standards like GPON (Recommendation ITU-T G.984.x [i.52]), XGS-PON (Recommendation ITU-T G.9807.x [i.53]), 50G-PON (Recommendation ITU-T G.9804.3 [33]), and coexistence with legacy systems (Recommendation ITU-T G.9805 [i.54]).	[Gap18-1]: Interoperability guidance for 50G-PON deployments are still under active development.
[R18-2]: Optical splitters shall meet IEC 61753-031-2 [47] insertion loss limits. As actual splitter insertion losses can vary by manufacturer and environmental conditions; achieving consistent loss is key to meet the power budget requirements when designing the network.	[Gap18-2]: None.
[R18-3]: Fibre should comply with G.657.A1 [49] for indoor and G.652.D [48] for outdoor with defined attenuation.	[Gap18-3]: None.
[R18-4]: Deployments should support dual homing protection type B/C with switchover less than 1 s.	[Gap18-4]: None.
[R18-5]: OLT and ONU should support at least AES-128 encryption. As the use case envisions to handle private data from patients, it would be desirable to support this feature.	[Gap18-5]: None.
[R18-6]: The PON network should support automatic ring network detection.	[Gap18-6]: Automatic ring network detection and disabling/re-enabling ONU ports to prevent broadcast storms is not currently supported explicitly in current ITU-T PON standards, and these procedures are typically implemented as vendor-specific (optional) features to improve network resilience.
[R18-7]: The network shall be able to provide logical separation of at least 4 virtual networks.	[Gap18-7]: None.
[R18-8]: The NMS should support a GUI and a RESTful API for the north bound interface.	[Gap18-8]: The support of management with common REST API schema or interfaces is currently not supported by PON management standards.
UC#19: Energy-efficiency by deactivating low-load ports	
[R19-1]: The Energy and Load Monitor shall collect port energy consumption and traffic load every second as mentioned in IETF RFC 9232 [38].	[Gap19-1]: No standard YANG model that provides energy-consumption metrics.
[R19-2]: The Energy and Load Monitor shall correlate measured energy with traffic statistics to compute energy-efficiency indicators as defined in ETSI ES 203 475 [39].	[Gap19-2]: No standard YANG model that provides enough information to calculate energy-efficiency metrics exist.
[R19-3]: The Traffic Analyser module shall analyse incoming telemetry in real-time to identify ports with persistently low utilization.	[Gap19-3]: None.
[R19-4]: The Traffic Analyser module shall predict the future load on each port.	[Gap19-4]: No standard way of communicating analyser decision to controller.
[R19-5]: The Decision Engine shall support intent or policy-driven logic to decide if and when to activate or deactivate low-power port mode.	[Gap19-5]: No intent-specific standards to translate operator request into energy-saving actions.
[R19-6]: The Decision Engine shall be aware of redundancy and constraints.	[Gap19-6]: None.
[R19-7]: The Decision Engine shall get guard timing from intent to avoid rapid fluctuations.	[Gap19-7]: None.
[R19-8]: The Execution Engine shall reroute the traffic to available alternative path with no impact on active flows.	[Gap19-8]: None.
[R19-9]: The Execution Engine shall be capable of transitioning the port into (and out of) low-power mode.	[Gap19-9]: No standard YANG model attribute to indicate port power saving status.
[R19-10]: The Port Manager shall support access via RESTCONF or NETCONF using standard model with rollback on error.	[Gap19-10]: None.
[R19-11]: The path availability shall maintain comprehensive topology and resource data to evaluate alternative paths.	[Gap19-11]: No standard metric for energy in routing protocols.

[R19-12]: The path availability shall compute alternative paths between the endpoints.	[Gap19-12]: No energy-aware protocol extension.
[R19-13]: The path availability should support multi-domain coordination.	[Gap19-13]: No unified multi-domain path availability interface focused on energy-efficiency.
[R19-14]: The Traffic Rerouting module shall identify all active flows on the selected port and dynamically reroute traffic onto the pre-computed alternative path without breaching SLAs.	[Gap19-14]: None.
[R19-15]: The Traffic Rerouting module shall support restoring traffic back to original path once the port returns to an active state.	[Gap19-15]: None.
[R19-16]: The low power port mode shall keep the link signalling alive.	[Gap19-16]: No standard model available to define low-power port mode.
UC#20: Cloud-based Object Wave Transmissions	
[R20-1]: For 4K streaming of the content, the compute functionality shall be capable of larger than 16 Peta-FLOPS (Floating-point Operations Per Second) per processing stream.	[Gap20-1]: None.
[R20-2]: For 4K streaming of the content, the storage capability shall be larger than 400 Megabytes.	[Gap20-2]: None.
[R20-3]: For 4K streaming of the content, the bandwidth requirement per stream shall be larger than 3Gbit/s.	[Gap20-3]: For large scale deployment, higher bandwidth network technologies are requirement, specifically in the CPN and AN segment.
[R20-4]: The network latency requirement shall be the same as in the Cloud VR latency requirements of Table 1 of clause 4.2 in ETSI GS F5G 013 [11].	[Gap20-4]: None.
[R20-5]: The control and management of F5G-A shall support the function to dynamically allocate rendering tasks to compute elements in the network.	[Gap20-5]: Converged control and management of networking and compute protocols and data models are not standardized.
UC#21: P2MP fgOTN for premium private lines	
[R21-1]: End-to-end fgOTN connection shall be supported over P2MP fibre network and P2P fibre network.	[Gap21-1]: Standards which support end-to-end fgOTN connection over P2MP fibre network and P2P fibre network are currently unavailable.
[R21-2]: For fgOTN over P2P and P2MP fibre network, end-to-end service provisioning and visualization shall be supported based on the unified network management and control.	[Gap21-2]: Standards which support End-to-end fgOTN service provisioning and visualization are currently unavailable.
[R21-3]: The split ratio of 1:8 to 1:16 of each P2MP network shall be supported.	[Gap21-3]: None.
[R21-4]: Hitless bandwidth adjustment in the case of an fgOTN (over P2P and P2MP) carrying an ETH service and CBR timing transparent transport in the case of an fgOTN carrying CBR service shall be supported.	[Gap21-4]: Standards which support hitless bandwidth adjustment for ETH service and timing transparent transport for CBR service are currently unavailable.
[R21-5]: In the case of an fgOTN (over P2P and P2MP), CBR timing transparent transport carrying CBR service shall be supported.	[Gap21-5]: Standards which support hitless bandwidth adjustment for timing transparent transport for CBR service are currently unavailable.
[R21-6]: Millisecond-level latency and few tens of microseconds latency variation for P2MP network shall be supported.	[Gap21-6]: Standards which support millisecond-level latency and few tens of microseconds latency variation for P2MP network are currently unavailable.
UC#22: Smart Sensor Cloud for AI in Industrial Manufacturing	
[R22-1]: The F5G-A network for process level applications system shall guarantee a latency of less than 1 ms.	[Gap22-1]: None.
[R22-2]: For motion control applications, the latency shall be less than 0,5 ms.	[Gap22-2]: Motion control latency of lower than 0,5 ms not currently available in standards.
[R22-3]: 10 Gbit/s - 1 Tbit/s network backbone.	[Gap22-3]: None.
[R22-4]: Redundant fibre network infrastructure.	[Gap22-4]: None.
[R22-5]: Last-mile connection ≥ 1 Gbit/s.	[Gap22-5]: None.
[R22-6]: The system shall comply with industry-specific security standards and regulations, including but not limited to ISO/SAE 21434 [42] (Automotive Cybersecurity), IEC 62443-1-1 [43] (Industrial Network Security), and GDPR (General Data Protection Regulation) for data privacy.	[Gap22-6]: End to end security across optical access and optical core network technology is not standardized on the optical and electrical layer, however it can be done with security standards on higher layers.
[R22-7]: The system shall implement secure authentication and access control mechanisms to prevent unauthorized access to industrial data.	[Gap22-7]: None.

[R22-8]: The system shall provide auditability and traceability of all data transactions to ensure compliance with industry norms and forensic analysis capabilities.	[Gap22-8]: Auditability and traceability on the F5G-A network is not standardized.
[R22-9]: The system shall incorporate real-time anomaly detection and intrusion prevention mechanisms tailored for AI-driven industrial automation.	[Gap22-9]: Anomaly detection and intrusion prevention standards are not available.
UC#23: Integrated NAS over FTTR	
[R23-1]: It shall support enhancing data durability through network data protection technology, specifically cloud data backup technology of transmitting local data to cloud storage space via the network, enabling offsite backup and recovery of data.	[Gap23-1]: The detailed network data protection for the NAS over FTTR system is not available.
[R23-2]: The FTTR network system shall provide encryption transmission capabilities to support both remote access to NAS through the home storage APP and the security of data transmission over networks and between the MFU and SFUs.	[Gap23-2]: Although the secure transmission mechanism is supported by the PON and FTTR system, the encryption and authentication are always disabled. Therefore, encryption and authentication mechanism specified for NAS application are always not available.
[R23-3]: The device should have firewall functionality, including remote external network firewalls and internal business firewalls.	[Gap23-3]: None.
[R23-4]: The integrated NAS over FTTR devices should have mutual identity authentication capabilities to prevent impersonation of MFU and SFU.	[Gap23-4]: None.
[R23-5]: APP level security is required.	[Gap23-5]: There is no specific security requirement or standard on APP level for user's home storage.
[R23-6]: Without affecting network services, FTTR should provide bandwidth greater than 1 000 Mbps.	[Gap23-6]: High bandwidth access should be provided for the NAS access by the FTTR network. Currently, the bandwidth of the fibre network is enough, while the bandwidth of the Wi-Fi® network is not guaranteed.
[R23-7]: FTTR should offer a data transmission channel with latency of less than 15 ms.	[Gap23-7]: Low latency for the data transmission channel is not defined in any FTTR related standard.
[R23-8]: FTTR should be capable of providing data access through a peer-to-peer channel with a bandwidth greater than 100 Mbps for remote access to improve work efficiency and data availability.	[Gap23-8]: An APP-flow based E2E network slicing function is a good approach to support remote access of integrated NAS over FTTR. There is no APP-flow level network slicing in current standards.
UC#24: Generating an Energy Map for sustainable F5G-Advanced networks	
[R24-1]: The Energy Watcher shall provide continuous stream of network traffic, energy utilization and environmental metrics from all relevant sources and domains in real-time.	[Gap24-1]: No standard YANG data model to report energy consumption of network devices.
[R24-2]: The Energy Watcher shall extract telemetry from heterogenous sources such as network equipment, sensors, and HVAC systems and energy supply systems.	[Gap24-2]: No standard model-driven approach that provides energy data from HVAC and energy supply systems.
[R24-3]: The Energy Watcher shall correlate energy consumption readings with the corresponding network elements and locations.	[Gap24-3]: No standard YANG model that defines energy efficiency metrics.
[R24-4]: The Energy Cost Calculator shall compute energy cost by combining both network energy consumption with energy source and pricing.	[Gap24-4]: No standardized energy efficiency metrics to streamline to cost calculation logic.
[R24-5]: The Energy Cost Calculator shall provide optimized insights and forecast future consumption and costs by leveraging AI/ML models.	[Gap24-5]: No standard interface is defined integrate AI/ML prediction/recommendation to controller.
[R24-6]: The Storage Database shall provide high-throughput telemetry storage without loss or significant delay.	[Gap24-6]: None.
[R24-7]: The Storage Database shall provide high data retention and easy and fast data access.	[Gap24-7]: None.
[R24-8]: The Energy Map Generator shall be able to correlate energy efficiency metrics with network topology and inventory information to generate meaningful overlays.	[Gap24-8]: No standard model or schema for creating an energy map that combines network topology and energy metrics.
[R24-9]: The Energy Map Generator shall generate energy hotspots based on historical energy monitoring data.	[Gap24-9]: None.
[R24-10]: The Energy Map Generator shall provide recommendations for network reconfiguration to improve energy efficiency.	[Gap24-10]: No standard interface to feed energy decision back to controller.

UC#25: Flat wheel detection using Distributed Acoustic Sensing (DAS)	
[R25-1]: The system shall identify and report a wheel flat event within ≤ 10 seconds from the train passage to enable near-real-time alerting.	[Gap25-1]: Deploy analytical signal-processing methods to detect periodic vibration peaks caused by flat wheels, and leverage AI/ML models to classify and rule out of other causes. No deep learning and machine learning databank to improve detection accuracy over time does exist and is not standardized.
[R25-2]: The position of a defect shall be detected with an accuracy of ± 10 m along the fibre span.	[Gap25-2]: Mapping between fibre length and track GPS coordinates is typically maintained in a Geographic Information System (GIS) file. This mapping can be refined through tapping tests and by leveraging GPS data from regular train operations, which are transmitted to the server to automatically correct positioning errors.
[R25-3]: The system shall detect wheel flat with impact energy equivalent to a $\geq 0,3$ mm flat depth at train speeds above 60 km/h.	[Gap25-3]: A standard procedure to ensure that vendor-specific technologies achieve the required detection sensitivity, along with standardized methods for verifying impact detection thresholds does not exist.
[R25-4]: The DAS interrogator shall process and stream data at a ≥ 1 kHz sampling rate per channel, ensuring sufficient temporal resolution to capture wheel-rail impact signals.	[Gap25-4]: Reduce network or edge-compute bottlenecks that limit real-time processing and data transmission, along with challenges in scaling storage and analysis.
[R25-5]: The monitoring system shall maintain $\geq 99,5$ % operational availability during railway service hours.	[Gap25-5]: Deployment shall use server-level infrastructure with redundant components and high-availability architecture. Maintenance windows shall be scheduled during non-operational hours (e.g. nights) to minimize disruption to continuous data acquisition and ensure uninterrupted system integrity.
[R25-6]: Fibre and interrogation equipment shall operate within -20 °C to $+60$ °C, with no degradation in sensing performance.	[Gap25-6]: To verify whether additional protective measures (e.g. climate-controlled housing) are required to maintain consistent sensitivity under extreme conditions.
[R25-7]: End-to-end data transmission (from DAS unit to analytics platform) shall exhibit ≤ 200 ms latency, ensuring timely defect reporting.	[Gap25-7]: Assess network delays, edge-compute buffering, and overall infrastructure to ensure the ≤ 200 ms end-to-end latency requirement is met under peak load.
[R25-8]: The system shall integrate with existing asset management or alarm systems via standardized APIs.	[Gap25-8]: A gap exists in the standardization of alerts and their formats. Railway operators could initially use their own formats and gradually work toward a common standard through a rail operator consortium.
[R25-9]: Fibre should be buried in the range of 15 to 30 cm below the ground for acceptable performance.	[Gap25-9]: None
UC#26: Integrated RFID over FTTR	
[R26-1]: The FTTR network shall support low transmission latency below the maximum transmission latency as shown in Table 1 for exchanging RFID protocol messages at different BLF.	[Gap26-1]: The current FTTR network can support 64 micro seconds (μ s) [7] transmission latency for 160 kbps BLF but cannot satisfies the requirement of higher BLF.
[R26-2]: The FTTR network shall provide sub-microsecond time synchronization in case of supporting beamforming.	[Gap26-2]: The ability of sub-microsecond time synchronization is not supported in FTTR network.
[R26-3]: The FTTR network shall provide less than 0,1 ppm frequency synchronization in case of supporting beamforming.	[Gap26-3]: The ability of frequency synchronization is not supported in FTTR network.
[R26-4]: The integrated RFID over FTTR system shall support coordinated control and management of FTTR and RFID.	[Gap26-4]: The coordinated control and management of FTTR and RFID currently not available.
[R26-5]: The coordinated control and management of FTTR and RFID shall monitor the operating status of RFID readers and configure the corresponding technical parameters to optimize RFID functionality.	[Gap26-5]: The monitoring and configuring of RFID readers over FTTR is currently not available.
UC#27: AI-Powered Intelligent Flash Disconnection Fault	
[R27-1]: The detection range should be at least over 140 km to accommodate all span distance scenarios in operators.	[Gap27-1]: Currently, the industry's capabilities can only achieve a range of approximately 80 ~ 120 km.
[R27-2]: The localization accuracy shall be within ± 20 m.	[Gap27-2]: At present, such a localization accuracy of ± 20 m is generally achievable in the industry.
[R27-3]: The near-end event blind zone should be less than 100 meters.	[Gap27-3]: Currently, the near-end event blind zone in the industry can only achieve a level of 500 m.
[R27-4]: The flash disconnection fault localization shall support a detection time lower than 200 ms.	[Gap27-4]: Regarding detection time, some in the industry can achieve minute-level, but most still operate at the hour level.

[R27-5]: The flash disconnection fault localization shall support accurately identifying flash disconnection faults of fibre bending, fibre cutting, and fibre connector loosening.	[Gap27-5]: Currently, the industry only supports fibre cutting detection.
UC#28: 3D video enabling via FTTR	
[R28-1]: In the case of local video transformation, the FTTR device shall support computing power to process AI assisted 2D-to-3D video transformation.	[Gap28-1]: The current FTTR device does not support computing power for AI applications.
[R28-2]: In the case of video transformation in the edge, the connected OLT shall support computing power to process AI assisted 2D-to-3D video transformation.	[Gap28-2]: The current OLT device does not support computing power for AI applications.
[R28-3]: The FTTR devices shall provide accurate synchronization technologies to the 3D glasses.	[Gap28-31]: The synchronization between FTTR devices and 3D glass is currently unavailable.
[R28-4]: Left-and-right eye real-time switching shall be supported in the 3D glasses.	[Gap28-42]: The 3D glass with left-and-right eye real-time switching is currently unavailable.
[R28-5]: The FTTR devices shall provide time delay adjustment for synchronization alignment.	[Gap28-53]: The adjustment of the time delay for the synchronization between 3D glass and display is currently unavailable.
[R28-6]: The FTTR system shall support 10 Gbps throughput.	[Gap28-64]: None.
[R28-7]: The FTTR system shall provide means to manage and control 3D glasses, including collection of working status, configuration and control.	[Gap28-75]: The FTTR system currently does not support the management and control of 3D glasses. The corresponding management and control interface as well as the communication methodology between FTTR devices and 3D glasses is unavailable.
[R28-8]: The FTTR system shall provide means to monitor the quality of 3D views, detect any faults and forward potential warning to the management platform.	[Gap28-86]: The data model and management entity according to this use case is currently unavailable.
UC#29: Optical cable Co-route detection based on DFOS technology combined with AI capability	
[R29-1]: The detection range should be at least over 140 km to accommodate all span distance scenarios in operators.	[Gap29-1]: Currently, the industry's capabilities can only achieve a range of approximately 80 ~ 120 km.
[R29-2]: The minimum fibre co-routing length that shall be detectable is less than 100 m.	[Gap29-2]: Standards which support the minimum fibre co-routing length less than 100 m are currently unavailable.
[R29-3]: The detection accuracy should be at least over 99.9 %, with a minimal proportion of suspected fibre co-routing cases requiring manual verification and confirmation.	[Gap29-3]: Currently, the industry's average detection accuracy is approximately 95 %.
[R29-4]: The Missed Detection Rate (MDR) shall be reduced to zero, meaning no fault events should go unreported.	[Gap29-4]: Currently, the industry's average Missed Detection Rate (MDR) remains around 1 %, indicating that a small portion of fault events still cannot be fully warned in advance.
[R29-5]: Fibre co-routing status shall be identified online, eliminating the need for manual physical tapping along optical fibre lines for detection.	[Gap29-5]: Currently, an external tapping source is required to determine the co-routing status.
[R29-6]: The routing status of a fibre pair (≥ 80 km at least) shall be determined within 1 hour, while simultaneously achieving automatic GIS-based route visualization and reconstruction.	[Gap29-6]: Currently, the fibre routing status is determined by manual tapping along the optical fibre lines, with a detection rate of only 5 - 6 km per day, resulting in extremely low efficiency and no GIS automatic reconstruction.
[R29-7]: The optical cable co-route detection shall support co-fibre transmission of service signals and detection signals, enabling Integrated Sensing And Communication (ISAC).	[Gap29-7]: Currently, dedicated idle fibres are required for detection purposes.
UC#30: Generative AI for F5G-A Network Management Tasks	
[R30-1]: The generative AI system shall support selective retrieval and dynamic context management, enabling only the most relevant data models, templates, or configuration examples to be provided to the Large Language Model (LLM).	[Gap30-1]: No standardized framework exists for integrating generative AI with network model repositories (YANG, OpenConfig, vendor extensions) in a scalable way.
[R30-2]: The system shall support secure use of vendor-specific configuration data, ensuring proprietary information can be included in context without violating confidentiality.	[Gap30-2]: Mechanisms for federated or privacy-preserving access to vendor data are not currently defined, making realistic, multi-vendor AI training and operation difficult.
[R30-3]: The generative AI system shall generate vendor-neutral configurations aligned with standard data models and management protocols.	[Gap30-3]: No standardized closed-loop pipeline exists to connect AI output with schema validators and pre-deployment testing; current approaches remain ad-hoc.

[R30-4]: The system shall perform automated validation of generated code against schema rules and provide a safe environment for pre-deployment verification.	[Gap30-4]: Some AI solutions continue to generate proprietary configuration outputs without standardized validation, preventing interoperability in multi-vendor networks.
[R30-5]: The generative AI system shall be deployable on-premise within operator infrastructure, ensuring compliance with NDA and data privacy obligations.	[Gap30-5]: No standard deployment guidelines exist for LLMs in telco-grade environments, including compute, redundancy, and OSS/NMS integration.
[R30-6]: The system shall provide a sandbox or digital twin environment where AI-generated configurations can be tested safely before deployment to live devices.	[Gap30-6]: While digital twin frameworks for networks exist, they are not designed to interface with generative AI agents or provide a standardized API for validation of AI-generated configurations.
UC#31: Distributed Intelligence with Privacy-Preserving Features for FTTR	
[R31-1]: FTTR networks shall support heterogeneous computing across OLT, MFU, and SFU modules to host distributed intelligence functions and AI workloads.	[Gap31-1]: Current FTTR hardware is optimized primarily for packet forwarding and basic control-plane tasks, lacking the computational capabilities required for AI-driven operations.
[R31-2]: Onboard computing hardware shall be integrated in the FTTR network elements, since it is essential for real-time decision making at the network edge.	[Gap31-2]: Most MFU and SFU devices contain only minimal processors for management and Graphical User Interfaces (GUIs), lacking any internal hardware required for processing of AI workloads.
[R31-3]: These processing components shall ensure low-latency processing of telemetry data and support advanced analytics applications including service recognition, anomaly detection and dynamic bandwidth optimization.	[Gap31-3]: Standards defining clear performance baselines/benchmarks and hardware extensibility requirements are missing, which are essential to ensure future network elements can integrate heterogeneous computing resources.
[R31-4]: The network shall automatically classify service flows and map them to their corresponding Quality of Service (QoS) requirements.	[Gap31-4]: Present FTTR solutions treat traffic largely as undifferentiated IP flows, relying on static QoS profiles, limiting the responsiveness to sudden changes in service demand or application mix.
[R31-5]: Real-time identification shall enable dynamic bandwidth allocation and prioritization, ensuring consistent user experience across diverse applications.	[Gap31-5]: There is currently no standardized method for per-flow service classification or feedback between SFU/MFU and OLT to adjust QoS parameters dynamically.
[R31-6]: SFU and MFU devices shall generate and stream fine-grained telemetry data - mirroring the OLT capabilities - to enable data-driven operations and analytics at the end-user location.	[Gap31-6]: Currently, SFU and MFU hardware typically expose only a GUI-based interface aimed at end users, with no native telemetry streaming, or basic SNMP or CLI capabilities.
[R31-7]: Telemetry data shall be accessible via secure APIs for integration with AI algorithms and pipelines, to facilitate predictive maintenance and real-time traffic and service analytics, which are critical capabilities for distributed intelligence, where decisions are made at multiple network layers.	[Gap31-7]: Operators and potential AI applications currently lack direct access to granular performance data from in-home ONUs.
[R31-8]: Telemetry data models and high-frequency, low-latency telemetry streaming protocols, exposing traffic counters, optical power levels, QoE metrics, shall be defined for SFU and MFU nodes, for them to stream anonymously these metrics to OLT and Edge Cloud for AI training and inference.	[Gap31-8]: Current standards do not define telemetry data models, streaming protocols, and security mechanisms for the SFU and MFU nodes, such as gNMI or telemetry streaming with lightweight encryption for end-user privacy preservation.
[R31-9]: To support sustainable network operations, SFU and MFU units shall provide accurate, real-time metrics on their power consumption, to allow green ICT policies for dynamic power control and optimization, as well as automated energy reporting.	[Gap31-9]: Current FTTR hardware does not include sensors or interfaces to report live power consumption (typically, solely the operation Voltage (V)), making it challenging to track energy efficiency or implement adaptive power-management strategies at the device level.
[R31-10]: Mechanisms to deploy, update, and retire ML models shall be supported and standardized across Edge Cloud, OLT, MFU, and SFU nodes with version control and rollback.	[Gap31-10]: Current network management systems are not designed for ML model distribution or federated learning, with no standard APIs between network controllers and MLOps pipelines being currently defined or existing.
[R31-11]: All telemetry and service-related data collected from SFU and MFU units within European deployments shall comply with the General Data Protection Regulation (GDPR), such that sensitive end-user information shall be anonymized or kept entirely local to prevent disclosure to the network operator.	[Gap31-11]: Currently, there is no uniform standard for anonymization or for restricting the export of sensitive data from FTTR customer premises.
[R31-12]: FTTR telemetry streaming standards shall mandate privacy-preserving data collection and define strict access control policies.	[Gap31-12]: With the lacking FTTR telemetry streaming standards, there are also no related specifications concerning privacy-by-design principles for telemetry data, including encryption, local processing of personally identifiable information, and user consent mechanisms to meet GDPR requirements.

[R31-13]: Multi-vendor interoperability for AI telemetry formats, control APIs, and model execution environments shall be designed and standardized.	[Gap31-13]: Current FTTR specifications do not define AI-related YANG models or container runtimes.
--	---

Table 3 is a list of suggested actions to gaps found in the present document, which might be addressed by ETSI ISG F5G. ETSI ISG F5G may address them in the F5G- A architecture or in new work items under ETSI directives. A number of actions might be left for other SDO/organizations to solve, but are not further detailed in Table 3.

Table 3: Suggested actions for identified gaps

SDO/Group	Suggested actions	Relevant gaps
ETSI ISG F5G	Define an E2E PON compute Collaboration function.	[Gap3-3]
	Standardize an F5G-A unified E2E latency control mechanism.	[Gap6-3]
	Define a protocol for the interface for collecting F5G-A Access Network service and network KQIs.	[Gap9-2]
	Define a portal in the Access Network QoE analysis system for user experience issues.	[Gap9-3], [Gap9-4]
	Define an F5G-A Access Network automatic reconfiguration mechanism.	[Gap9-5]
	Define a users' service experience problem trouble tickets despatching system in the F5G-A Access Network QoE analysis system.	[Gap9-6]
	Define a computing coordination mechanism between different F5G-A network elements.	[Gap10-2]
	Define an adaptation mechanism to manage the variation of network demand due to the cloud desktop service.	[Gap10-3]
	Define a standard for sub 1 ms latency for robotic system using the F5G-A network.	[Gap14-2]
	Define a standard for sub 0,5 ms latency for safety cases for robotic system using the F5G-A network.	[Gap14-4]
	Define a standard for ideal cable requirements of $\pm 180^\circ$ twist per meter.	[Gap14-7]
	Define a standard for ideal cable bend for 12,5 times the outer diameters.	[Gap14-8]
	Define a simplified installation and configuration mechanism for enterprise network communication for RaaS applications effectively.	[Gap14-9]
	Define a mapping for DDS over the F5G-A network architecture.	[Gap14-10]
	Define a QoD standard for F5G-A networks.	[Gap17-1]
	Define a standard for the provisioning of App-Flow services with different QoS requirements.	[Gap17-2]
	Define a standard for SLA management of fine granular application flows.	[Gap17-3]
	Define a standard for fine granular application flow QoS management mechanisms with very low reaction time.	[Gap17-4]
	Define a standard for real-time QoS control subsystem in the CPN and in the Access Network.	[Gap17-5]
	Define a standard for the identification of fine granular application flows through the QoD API in the F5G-A network.	[Gap17-6]
	Define a standard for automatic identification of application flows in the F5G-A network.	[Gap17-7]
	Define a standard for the mapping of fine granular application flows QoD requests to underlying QoS guaranteed connections.	[Gap17-8]
	Define a telemetry collection standard for a very large number of application flows.	[Gap17-9]
	Define a standard for cooperation of compute located on different F5G-A Access Network and CPN equipment.	[Gap17-11]
	Define tests for 50G-PON coexistence with GPON and XGS-PON.	[Gap18-1]
	Specify best current practices when using legacy GPON in an environment with high security demands.	[Gap18-5]
	Define a standard for automatic ring network detection.	[Gap18-6]
	Define a standard north-bound interface (REST API) of the PON management system to be integrated into the enterprise management systems.	[Gap18-8]
	Define a standard YANG model for energy-consumption metrics.	[Gap19-1], [Gap24-1]
	Define a standard YANG model for energy-efficiency metrics.	[Gap19-2], [Gap24-3]
	Define a standards interface between the energy analyses and controller component in energy management systems.	[Gap19-4]
	Define an intent-based interface for operators request energy-saving actions.	[Gap19-5]

SDO/Group	Suggested actions	Relevant gaps
	Define a standard YANG model for port power saving status.	[Gap19-9]
	Define a standard metric for energy related parameters in routing protocols.	[Gap19-11]
	Define standard protocol extensions to be energy-aware.	[Gap19-12]
	Define a standard for multi-domain path availability interface focused on energy-efficiency.	[Gap19-13]
	Define a standard management model for low-power port mode.	[Gap19-16]
	Define a standard for networking and compute converged management and control protocols and data models.	[Gap20-5]
	Define a standard for End-to-end fgOTN service provisioning over P2MP fibre networks.	[Gap21-2]
	Define a standard for F5G-A network auditability and traceability.	[Gap22-8]
	Define a standard for F5G-A network anomaly detection and intrusion prevention.	[Gap22-9]
	Define a standard for NAS data protection.	[Gap23-1]
	Define a standard for FTTR APP-flow level network slicing.	[Gap23-8]
	Define a standard YANG model for heating, ventilation, and air conditioning (HVAC) units and energy supply systems.	[Gap24-2]
	Define a standard energy efficiency metrics useful for energy cost calculations.	[Gap24-4]
	Define a standard interface for integrating AI/ML prediction algorithms into a network energy controller.	[Gap24-5]
	Define a standard data model for an energy map.	[Gap24-8]
	Define a standard interface between an energy decision maker and a network controller.	[Gap24-10]
	Define a standard for fibre sensing database for improving detection accuracy.	[Gap25-1]
	Define a standard interface to support the addition of location data to fibre sensor management system.	[Gap25-2]
	Define standards for the environmental robustness of the sensing system.	[Gap25-6]
	Define standards for coordinated control and management of FTTR and RFID.	[Gap26-4]
	Define standards for monitoring and configuring RFID readers over FTTR.	[Gap26-5]
	Define a standard for FTTR computing power to be used by AI applications.	[Gap28-1], [Gap31-1], [Gap31-2]
	Define a standard for an OLT computing power to be used by AI applications.	[Gap28-2]
	Define a standard for the synchronization between FTTR devices and 3D glasses including time delay synchronization.	[Gap28-3], [Gap28-5]
	Define a standard for managing 3D glasses including management and control interfaces and data models.	[Gap28-7], [Gap28-8]
	Define a standard framework for integrating generative AI with network model repositories.	[Gap30-1]
	Define a standard for privacy preserving access to vendor data of the network devices.	[Gap30-2]
	Define a standard for closed-loop pipelines connecting AI algorithm output with schema validation and deployment testing components.	[Gap30-3]
	Describe LLM deployment guidelines in telco environments.	[Gap30-5]
	Define a standards interface between digital twin data of the network and the generative AI agents.	[Gap30-6]
	Define a standard for computing performance benchmarks for compute functionality on network elements.	[Gap31-3]
	Define a standard for FTTR per-flow service QoS including per-flow service classification.	[Gap31-4], [Gap31-5]
	Define a standard for FTTR telemetry streaming including protocol and data model.	[Gap31-6]
	Define a standard for a data model with fine-granular performance data.	[Gap31-7]
	Define a standard interface between the FTTR system and OLTs for streaming telemetry data with lightweight encryption for end-user privacy preservation.	[Gap31-8]
	Define a standard FTTR management framework for the integration of AI/ML components and a standard interface between a network controller and AI pipelines.	[Gap31-10]
	Define a standard for anonymizing sensitive data from customer premises networks.	[Gap31-11]

SDO/Group	Suggested actions	Relevant gaps
	Define a standard for a telemetry with privacy by design principles including the telemetry data, encryption, and local processing of personalized data and conforming to regional privacy requirement.	[Gap31-12]
	Define a standard for AI-related YANG models for FTTR network element access.	[Gap31-13]
ETSI TC ATTM	ETSI ISG F5G suggests that ETSI TC ATTM should define a dynamic visualization mechanism of the ODN topology between the OLT and the ONU.	[Gap11-1]
	ETSI ISG F5G suggests that ETSI TC ATTM should define the use of GIS-based location identification for the ODN.	[Gap11-2]
	ETSI ISG F5G suggests that ETSI TC ATTM should define a mechanism for dynamic collection of the ODN insertion loss.	[Gap11-3]
	ETSI ISG F5G suggests that ETSI TC ATTM should define an ODN proactive optical path diagnostics mechanism.	[Gap11-4]
	ETSI ISG F5G suggests that ETSI TC ATTM should define an ODN remote fault locating mechanism.	[Gap11-5]
	ETSI ISG F5G suggests that ETSI TC ATTM should define an ODN resource management system.	[Gap11-6]
ETSI ISG ZSM	ETSI ISG F5G suggests that ETSI ISG ZSM should define a standard for the provisioning of App-Flow services with different QoS requirements.	[Gap17-2]
	ETSI ISG F5G suggests that ETSI ISG ZSM should define a standard for SLA management of fine granular application flows.	[Gap17-3]
	ETSI ISG F5G suggests that ETSI ISG ZSM should define a standard for fine granular application flow QoS management mechanisms with very low reaction time.	[Gap17-4]
ITU-T SG15/Q2	ETSI ISG F5G suggests that ITU-T SG15/Q2 should define additional computing hardware or modules for PON network equipment.	[Gap3-1]
	ETSI ISG F5G suggests that ITU-T SG15/Q2 should define a dynamic and quantitative QoS indication scheme for data flows for the PON network.	[Gap3-2]
	ETSI ISG F5G suggests that ITU-T SG15/Q2 should define an OMCI computing collaboration data model.	[Gap3-5]
	ETSI ISG F5G suggests that ITU-T SG15/Q2 should define a standard enabling the OLT the direct collection of E-ONU transmission status.	[Gap7-1]
	ETSI ISG F5G suggests that ITU-T SG15/Q2 define a standard enabling the OLT to directly configure the E-ONUs.	[Gap7-2]
	ETSI ISG F5G suggests that ITU-T SG15/Q2 should define a standard to extent OMCI to manage the on-premises network.	[Gap7-4]
	ETSI ISG F5G suggests that ITU-T SG15/Q2 should define a standard for a unified management system between the OLT, the P-ONUs and E-ONUs.	[Gap7-5]
	ETSI ISG F5G suggests that ITU-T SG15/Q2 should define a standard for a single protocol for device information collection.	[Gap7-6]
	ETSI ISG F5G suggests that ITU-T SG15/Q2 should define a standard for a unified management system to directly collect device information for both the P-ONU and E-ONUs.	[Gap7-7]
	ETSI ISG F5G suggests that ITU-T SG15/Q2 should define a standard for a unified management system enabling visualization of the logical link for different service flow.	[Gap7-8]
	ETSI ISG F5G suggests that ITU-T SG15/Q2 should define an ONU standard with computing-enhanced functionality.	[Gap17-10]
	ETSI ISG F5G suggests that ITU-T SG15/Q2 should define a standard for higher-bandwidth networks in the CPN and AN for large scale deployments of OWT.	[Gap20-3]
	ETSI ISG F5G suggests that ITU-T SG15/Q2 should define a standard for extreme low latency (lower than 0,5 ms) networking for motion control applications.	[Gap22-2]
ITU-T SG15/Q3	ETSI ISG F5G suggests that ITU-T SG15/Q3 should define the on-premises real time Wi-Fi® channel information collection.	[Gap2-3]
	ETSI ISG F5G suggests that ITU-T SG15/Q3 should define the on-premises messaging mechanism and data model for Wi-Fi® transmission coordination over the fibre link.	[Gap2-4], [Gap2-5], [Gap2-6], [Gap2-7]
	ETSI ISG F5G suggests that ITU-T SG15/Q3 should define additional computing hardware or modules for PON on-premises network equipment.	[Gap3-1]
	ETSI ISG F5G suggests that ITU-T SG15/Q3 should define a FMCI computing collaboration data model in.	[Gap3-6]

SDO/Group	Suggested actions	Relevant gaps
	ETSI ISG F5G suggests that ITU-T SG15/Q3 should define a standard enabling the OLT the direct collection of E-ONU transmission status.	[Gap7-1]
	ETSI ISG F5G suggests that ITU-T SG15/Q3 should define a standard enabling the OLT to directly configure the E-ONUs.	[Gap7-2]
	ETSI ISG F5G suggests that ITU-T SG15/Q2 should define a standard for a unified management system between the OLT, the P-ONUs and E-ONUs.	[Gap7-5]
	ETSI ISG F5G suggests that ITU-T SG15/Q3 should define a standard for a single protocol for device information collection.	[Gap7-6]
	ETSI ISG F5G suggests that ITU-T SG15/Q3 should define a standard for a unified management system to directly collect device information for both the P-ONU and E-ONUs.	[Gap7-7]
	ETSI ISG F5G suggests that ITU-T SG15/Q3 should define a standard for low-latency FTTR.	[Gap23-7], [Gap26 1]
	ETSI ISG F5G suggests that ITU-T SG15/Q3 should define a standard for sub-microsecond time synchronization in FTTR networks.	[Gap26-2]
	ETSI ISG F5G suggests that ITU-T SG15/Q3 should define a standard for frequency synchronization in FTTR networks.	[Gap26-3]
ITU-T SG15/Q6	ETSI ISG F5G suggests that ITU-T SG15/Q6 should define the appropriate technology for Ultra-long single-span of 500 km.	[Gap4-3]
	ETSI ISG F5G suggests that ITU-T SG15/Q6 should define fibre standards for railway track intrusion sensing.	[Gap5-1], [Gap5-2], [Gap5-3], [Gap5-4], [Gap5-5]
	ETSI ISG F5G suggests that ITU-T SG15/Q6 should define a standard for wavelength sharing between different rings in wavelength-shared WDM.	[Gap13-2]
	ETSI ISG F5G suggests that ITU-T SG15/Q6 should define multiple-ring multi-service access network structure with the reuse of wavelengths per node.	[Gap13-3]
	ETSI ISG F5G suggests that ITU-T SG15/Q6 should define a standard for a function model of an integrated ROADM with higher integration, smaller size, and lower power.	[Gap13-5]
	ETSI ISG F5G suggests that ITU-T SG15/Q6 should define a mechanism for real-time monitoring of individual channels and transmission links.	[Gap13-7]
	ETSI ISG F5G suggests that ITU-T SG15/Q6 should define a mechanism for automatic allocation of wavelength resources and network optimization.	[Gap13-8]
	ETSI ISG F5G suggests that ITU-T SG15/Q6 should define a standard to enabling vibration waveform detection distance greater than 80 km.	[Gap16-1]
	ETSI ISG F5G suggests that ITU-T SG15/Q6 should define a standard for $\leq 1\%$ false negative and false positive detection rate.	[Gap16-2]
	ETSI ISG F5G suggests that ITU-T SG15/Q6 should define a standard for vibration waveform detection accuracy of $< 95\%$.	[Gap16-3]
	ETSI ISG F5G suggests that ITU-T SG15/Q6 should define a standard for event location accuracy ≤ 10 m.	[Gap16-4]
	ETSI ISG F5G suggests that ITU-T SG15/Q6 should define a standard for a self-adaptive sensing system.	[Gap16-5]
	ETSI ISG F5G suggests that ITU-T SG15/Q6 should define a standard with real-time sensing monitoring capability.	[Gap16-6]
	ETSI ISG F5G suggests that ITU-T SG15/Q6 should define a standard which define the fibre sensing system architecture, the optical interface, the electronic interface and the management & control, and enabling communication hardware reuse or supply chain reuse.	[Gap16-8]
	ETSI ISG F5G suggests that ITU-T SG15/Q6 should define a standard for detection of disconnections in a fibre span larger than 140 km.	[Gap27-1]
	ETSI ISG F5G suggests that ITU-T SG15/Q6 should define a standard for detection of disconnections with a location accuracy of ± 20 m.	[Gap27-2]
	ETSI ISG F5G suggests that ITU-T SG15/Q6 should define a standard for detection of disconnections mechanism with near-end event blind zone less than 100 m.	[Gap27-3]
	ETSI ISG F5G suggests that ITU-T SG15/Q6 should define a standard for detection of disconnections with a detection time lower than 200 ms.	[Gap27-4]
	ETSI ISG F5G suggests that ITU-T SG15/Q6 should define a standard for accurate identification of disconnections due to fibre bending, fibre cuts, or fibre connector loosening.	[Gap27-5]
	ETSI ISG F5G suggests that ITU-T SG15/Q6 should define a standard for cable co-route detection with fibre spans larger than 140 km.	[Gap29-1]
	ETSI ISG F5G suggests that ITU-T SG15/Q6 should define a standard for cable co-route detection of co-routing length less than 100 m.	[Gap29-2]

SDO/Group	Suggested actions	Relevant gaps
	ETSI ISG F5G suggests that ITU-T SG15/Q6 should define a standard for cable co-route detection with a detection accuracy of 99,9 % or better.	[Gap29-3]
	ETSI ISG F5G suggests that ITU-T SG15/Q6 should define a standard for cable co-route detection with zero missed detections.	[Gap29-4]
	ETSI ISG F5G suggests that ITU-T SG15/Q6 should define a standard for cable co-route detection without external or manual tapping.	[Gap29-5]
	ETSI ISG F5G suggests that ITU-T SG15/Q6 should define a standard for cable co-route detection supporting automated GIS-based route visualization, an >80km detection span within lower than 1 hour.	[Gap29-6]
	ETSI ISG F5G suggests that ITU-T SG15/Q6 should define a standard for cable co-route detection without idle fibre for detection purposes.	[Gap29-7]
ITU-T SG15/Q7	ETSI ISG F5G suggests that ITU-T SG15/Q7 should define a dynamic visualization mechanism of the ODN topology between the OLT and the ONU.	[Gap11-1]
	ETSI ISG F5G suggests that ITU-T SG15/Q7 should define the use of GIS-based location identification for the ODN.	[Gap11-2]
	ETSI ISG F5G suggests that ITU-T SG15/Q7 should define a mechanism for dynamic collection of the ODN insertion loss.	[Gap11-3]
	ETSI ISG F5G suggests that ITU-T SG15/Q7 should define an ODN proactive optical path diagnostics mechanism.	[Gap11-4]
	ETSI ISG F5G suggests that ITU-T SG15/Q7 should define an ODN remote fault locating mechanism.	[Gap11-5]
	ETSI ISG F5G suggests that ITU-T SG15/Q7 should define an ODN resource management system.	[Gap11-6]
ITU-T SG15/Q11	ETSI ISG F5G suggests that ITU-T SG15/Q11 should define a standard supporting end-to-end fgOTN connections over P2MP fibre networks.	[Gap21-1]
	ETSI ISG F5G suggests that ITU-T SG15/Q11 should define a standard supporting hitless bandwidth adjustment for ETH service and timing transparent transport for CBR service.	[Gap21-4]
	ETSI ISG F5G suggests that ITU-T SG15/Q11 should define a standard supporting millisecond-level latency and few tens of microseconds latency variation for P2MP network.	[Gap21-5]
ITU-T SG15/Q14	ETSI ISG F5G suggests that ITU-T SG15/Q14 should define a standard for root alarm identification to report aggregated alarms.	[Gap8-2]
	ETSI ISG F5G suggests that ITU-T SG15/Q14 should enhance the OTN fault management system to support OTN root cause analysis of correlated alarms.	[Gap8-3]
	ETSI ISG F5G suggests that ITU-T SG15/Q14 should enhance the OTN fault management system to support OTN fault repair recommendations.	[Gap8-4]
	ETSI ISG F5G suggests that ITU-T SG15/Q14 should enhance the OTN fault management system to support fault impact analysis.	[Gap8-5]
	ETSI ISG F5G suggests that ITU-T SG15/Q14 should enhance the OTN fault management system to provide fault handling priorities.	[Gap8-6]
	ETSI ISG F5G suggests that ITU-T SG15/Q14 should enhance the OTN fault management system to support incident information reporting.	[Gap8-7]
ITU-T SG16	ETSI ISG F5G suggests that ITU-T SG16 should define shallow compression techniques with low compression ratio for Cloud desktop services.	[Gap10-5]
	ETSI ISG F5G suggests that ITU-T SG16 should define independent encoding and decoding processes for shallow compression of each frame.	[Gap10-6]
	ETSI ISG F5G suggests that ITU-T SG16 should define parallel compression for cloud desktop service slices.	[Gap10-7]
IEC TC86	ETSI ISG F5G suggests that IEC TC86 define a standard for ideal cable requirements of $\pm 180^\circ$ twist per meter.	[Gap14-7]
	ETSI ISG F5G suggests that IEC TC86 should define a standard for ideal cable bend for 12,5 times the outer diameters.	[Gap14-8]
IEEE 802.11	ETSI ISG F5G suggests that IEEE 802.11 should define a sub-6 GHz alignment with mmWave Wi-Fi®.	[Gap12-1]
	ETSI ISG F5G suggests that IEEE 802.11 should define a coordinated transmission mechanism supporting the new 6 GHz aligned system specification.	[Gap12-2]
	ETSI ISG F5G suggests that IEEE 802.11 should define a data model for Wi-Fi® devices.	[Gap12-3]

SDO/Group	Suggested actions	Relevant gaps
	ETSI ISG F5G suggests that IEEE 802.11 should define a coordination mechanism between sub-6 GHz and mmWave Wi-Fi® for link switching.	[Gap12-4]
	ETSI ISG F5G suggests that IEEE 802.11 should define a sub-6 GHz Wi-Fi® assistance mechanism for mmWave Wi-Fi® beamforming, beam tracking and link adaptation.	[Gap12-5]
	ETSI ISG F5G suggests that IEEE 802.11 should define an independent control and data plane for mmWave Wi-Fi® via sub-6 GHz Wi-Fi®.	[Gap12-6]
IETF	ETSI ISG F5G suggests that IETF should define the real-time resource discovery of fgOTN resources.	[Gap1-1]
	ETSI ISG F5G suggests that IETF should define the YANG model for fgOTN for provisioning, alarm handling, and hitless Bandwidth resizing.	[Gap1-2], [Gap1-5], [Gap1-6]
	ETSI ISG F5G suggests that IETF should define an automatic discovery and automatic configuration of the OTN CPEs allowing for CPE plug and play.	[Gap1-3]
	ETSI ISG F5G suggests that IETF should define the YANG models for the information identified reporting of an identified incident.	[Gap8-8]
	ETSI ISG F5G suggests that IETF define a standard YANG model for port power saving status.	[Gap19-9]
BBF	ETSI ISG F5G suggests that BBF should add a computing collaboration data model to BBF TR-069 [i.14] and BBF TR-369 [i.15].	[Gap3-4]
	ETSI ISG F5G suggests that BBF define a standard YANG model for energy-consumption metrics.	[Gap19-1], [Gap24-1]
	ETSI ISG F5G suggests that BBF define a standard YANG model for energy-efficiency metrics.	[Gap19-2], [Gap24-3]
	ETSI ISG F5G suggests that BBF define a standard YANG model for port power saving status.	[Gap19-9]
Rail operator standards consortium	ETSI ISG F5G suggests that a rail operator standards consortium defines a standard for alerts of flat wheels detected and the interface into the railway alarm systems.	[Gap25-8]
	No action needed.	Gaps with None

History

Version	Date	Status
V1.1.1	April 2026	Publication