



ETSI
TECHNICAL
REPORT

ETR 273-7

February 1998

Source: ERM

Reference: DTR/ERM-RP01-018-7

ICS: 33.020

Key words: Analogue, data, measurement uncertainty, mobile, radio, testing

**Electromagnetic compatibility
and Radio spectrum Matters (ERM);
Improvement of radiated methods of
measurement (using test sites) and
evaluation of the corresponding
measurement uncertainties;
Part 7: Artificial human beings**

ETSI

European Telecommunications Standards Institute

ETSI Secretariat

Postal address: F-06921 Sophia-Antipolis CEDEX - FRANCE

Office address: 650 Route des Lucioles - Sophia Antipolis - Valbonne - FRANCE

X.400: c=fr, a=atlas, p=etsi, s=secretariat - **Internet:** secretariat@etsi.fr

Tel.: +33 4 92 94 42 00 - Fax: +33 4 93 65 47 16

Copyright Notification: No part may be reproduced except as authorized by written permission. The copyright and the foregoing restriction extend to reproduction in all media.

© European Telecommunications Standards Institute 1998. All rights reserved.

Contents

Foreword	5
1 Scope	7
2 References	7
3 Definitions, symbols and abbreviations	8
3.1 Definitions	8
3.2 Symbols	12
3.3 Abbreviations	14
4 Introduction	15
4.1 Artificial human beings	15
4.1.1 Saltwater column	15
4.1.2 Salty man	16
4.1.3 "Salty-lite"	16
4.1.4 Other salties	16
4.2 Simulation of the human form	17
4.3 Test conditions	17
5 Uncertainty contributions specific to Salty man/Salty-lite	19
5.1 Comparison between average humans and Salties	19
5.2 Uncertainties associated with the use of Salty man and Salty-lite	20
5.3 Measurement considerations for Salty man and Salty-lite	21
5.3.1 Frequency ranges	21
5.3.2 Uncertainties of use	21
5.3.3 Conclusion	22
6 Verification procedure for the Salty man and Salty-lite	22
6.1 Definition	22
6.2 Overview of the verification procedure	23
6.2.1 Apparatus required	24
6.2.2 Site preparation	24
6.2.3 Measurement configuration	24
6.2.4 What to record	24
6.3 Verification procedure	24
6.4 Processing the results of the verification procedure	25
6.4.1 Report format	25
6.5 Calculation of measurement uncertainty	25
6.5.1 Introduction	25
6.5.2 Discussion of uncertainty contributions	25
6.5.3 Uncertainty contribution, actual measurement	26
7 Test methods	26
7.1 Introduction	26
7.1.1 Site preparation	27
7.1.2 Preparation of the EUT	27
7.1.3 Standard antennas	28
7.1.4 Mutual coupling and mismatch loss correction factors	28
7.1.5 Power supplies to the EUT	29
7.1.6 Restrictions	29
7.2 Transmitter tests	29
7.2.1 Frequency error	29
7.2.2 Effective radiated power	29

7.2.3	Spurious emissions	29
7.2.4	Adjacent channel power	29
7.3	Receiver tests	29
7.3.1	Sensitivity tests in an anechoic chamber (30 to 1 000 MHz).....	30
7.3.1.1	Apparatus required.....	30
7.3.1.2	Method of measurement.....	31
7.3.1.3	Procedure for completing the results sheets	37
7.3.1.4	Log book entries	38
7.3.1.5	Statement of results	40
7.3.2	Measurement uncertainty for Receiver Sensitivity (anechoic chamber)	41
7.3.2.1	Uncertainty contributions: Stage 1: Determination of transform factor	41
7.3.2.2	Uncertainty contributions: Stage 2: EUT measurement	42
7.3.2.3	Expanded uncertainty of the receiver sensitivity measurement.....	44
7.3.3	Sensitivity tests in an anechoic chamber with ground plane (30 MHz to 1 000 MHz)	44
7.3.3.1	Apparatus required.....	44
7.3.3.2	Method of measurement.....	45
7.3.3.3	Procedure for completion of the results sheets	50
7.3.3.4	Log book entries	51
7.3.3.5	Statement of results	53
7.3.4	Measurement uncertainty for Receiver Sensitivity	54
7.3.4.1	Uncertainty contributions: Stage 1: Determination of transform factor	54
7.3.4.2	Uncertainty contributions: Stage 2: EUT measurement	56
7.3.4.3	Expanded uncertainty of the receiver sensitivity measurement.....	57
7.3.5	Sensitivity tests (open area test site) (30 to 1 000 MHz)	57
7.3.5.1	Apparatus required.....	57
7.3.5.2	Method of measurement.....	58
7.3.5.3	Procedure for completion of the results sheets	63
7.3.5.4	Log book entries	64
7.3.5.5	Statement of results	66
7.3.6	Measurement uncertainty for Receiver Sensitivity	67
7.3.6.1	Uncertainty contributions: Stage 1: Determination of transform factor	67
7.3.6.2	Uncertainty contributions: Stage 2: EUT measurement	68
7.3.6.3	Expanded uncertainty of the receiver sensitivity measurement.....	70
7.3.7	Co-channel rejection.....	70
7.3.8	Adjacent channel selectivity	70
7.3.9	Intermodulation immunity	70
7.3.10	Blocking immunity or desensitization	70
7.3.11	Spurious response rejection.....	70
Annex A (informative):	Bibliography	71
History.....		73

Foreword

This ETSI Technical Report (ETR) has been produced by the Electromagnetic compatibility and Radio spectrum Matters (ERM) Technical Committee of the European Telecommunications Standards Institute (ETSI).

ETRs are informative documents resulting from ETSI studies which are not appropriate for European Telecommunication Standard (ETS) or Interim European Telecommunication Standard (I-ETS) status. An ETR may be used to publish material which is either of an informative nature, relating to the use or the application of ETSs or I-ETSs, or which is immature and not yet suitable for formal adoption as an ETS or an I-ETS.

The present document is part 7 of a multi-part Technical Report (ETR) covering Electromagnetic compatibility and Radio spectrum Matters (ERM); Improvement of radiated methods of measurement (using test sites) and evaluation of the corresponding measurement uncertainties, as identified below:

- Part 1-1: "Uncertainties in the measurement of mobile radio equipment characteristics; Sub-part 1: Introduction";
- Part 1-2: "Uncertainties in the measurement of mobile radio equipment characteristics; Sub-part 2: Examples and annexes";
- Part 2: "Anechoic chamber";
- Part 3: "Anechoic chamber with a ground plane";
- Part 4: "Open area test site";
- Part 5: "Striplines";
- Part 6: "Test fixtures";
- Part 7: "Artificial human beings".**

Blank page

1 Scope

This ETR covers the methods of radiated measurements on mobile radio equipment using Salty columns/artificial human beings and applies to the assessment of the associated measurement uncertainties.

This ETR also provides the methods for evaluation and calculation of the measurement uncertainties for each of the measured parameters and the required corrections for measurement conditions and results.

2 References

Within this ETR the following references apply:

- [1] ANSI C63.5-(1988): "Electromagnetic Compatibility-Radiated Emission Measurements in Electromagnetic Interference (EMI) Control - Calibration of Antennas".
- [2] CCITT Recommendation O.41: "Psophometer for use on telephone-type circuits".
- [3] CCITT Recommendation O.153: "Basic parameters for the measurement of error performance at bit rates below the primary rate".
- [4] "*Chambers Science and Technology dictionary*", 1988. Published by Chambers Cambridge.
- [5] "*Computer simulation and measurements of electromagnetic fields close to phantom Humans*", Electricity and magnetism in biology and medicine by Martin Blank, Ed 1993 San Francisco Press.
- [6] ETR 273-1-1: "Electromagnetic compatibility and Radio spectrum Matters (ERM); Improvement of radiated methods of measurement (using test sites) and evaluation of the corresponding measurement uncertainties; Part 1: Uncertainties in the measurement of mobile radio equipment characteristics; Sub-part 1: Introduction".
- [7] ETR 273-1-2: "Electromagnetic compatibility and Radio spectrum Matters (ERM); Improvement of radiated methods of measurement (using test sites) and evaluation of the corresponding measurement uncertainties; Part 1: Uncertainties in the measurement of mobile radio equipment characteristics; Sub-part 2: Examples and annexes".
- [8] IEC 489-6: "Methods of measurement for radio equipment used in the mobile services. Part 6: Selective-calling and data equipment".
- [9] "*Use of Simulated Human Bodies in pager receiver sensitivity measurements*", K.Siwak and W.Elliott III. Southcom /92 conference, Orlando 1992. pp 189/92.
- [10] "*Radiowave propagation and antennas for personal communications*", K. Siwak, Artech House Publications.

3 Definitions, symbols and abbreviations

3.1 Definitions

For the purposes of this ETR, the following definitions apply:

Audio Frequency (AF) load: Normally a resistor of sufficient power rating to accept the maximum audio output power from the EUT. The value of the resistor is normally that stated by the manufacturer and is normally the impedance of the audio transducer at 1 000 Hz.

NOTE 1: In some cases it may be necessary to place an isolating transformer between the output terminals of the receiver under test and the load.

A-M1: A test modulation consisting of a 1 000 Hz tone at a level which produces a deviation of 12 % of the channel separation.

A-M2: A test modulation consisting of a 1 250 Hz tone at a level which produces a deviation of 12 % of the channel separation.

A-M3: A test modulation consisting of a 400 Hz tone at a level which produces a deviation of 12 % of the channel separation. This signal is used as an unwanted signal for analogue and digital measurements.

AF termination: Any connection other than the audio frequency load which may be required for the purpose of testing the receiver. (i.e. in a case where it is required that the bit stream be measured, the connection may be made, via a suitable interface, to the discriminator of the receiver under test).

NOTE 2: The termination device is normally agreed between the manufacturer and the testing authority and details included in the test report. If special equipment is required then it is normally provided by the manufacturer.

antenna: That part of a transmitting or receiving system that is designed to radiate or to receive electromagnetic waves.

antenna factor: Quantity relating the strength of the field in which the antenna is immersed to the output voltage across the load connected to the antenna. When properly applied to the meter reading of the measuring instrument, yields the electric field strength in V/m or the magnetic field strength in A/m.

antenna gain: The ratio of the maximum radiation intensity from an (assumed lossless) antenna to the radiation intensity that would be obtained if the same power were radiated isotropically by a similarly lossless antenna.

bit error ratio: The ratio of the number of bits in error to the total number of bits.

combining network: A multipole network allowing the addition of two or more test signals produced by different sources for connection to a receiver input.

NOTE 3: Sources of test signals are normally connected in such a way that the impedance presented to the receiver is 50 Ω . The combining networks are designed so that effects of any intermodulation products and noise produced in the signal generators are negligible.

correction factor: The numerical factor by which the uncorrected result of a measurement is multiplied to compensate for an assumed systematic error.

confidence level: The probability of the accumulated error of a measurement being within the stated range of uncertainty of measurement.

directivity: The ratio of the maximum radiation intensity in a given direction from the antenna to the radiation intensity averaged over all directions (i.e. directivity = antenna gain + losses).

DM-0: A test modulation consisting of a signal representing an infinite series of "0" bits.

DM-1: A test modulation consisting of a signal representing an infinite series of "1" bits.

DM-2: A test modulation consisting of a signal representing a pseudorandom bit sequence of at least 511 bits in accordance with CCITT Recommendation O.153 [3].

DM-3: A test signal agreed between the testing authority and the manufacturer in the cases where it is not possible to measure a bit stream or if selective messages are used and are generated or decoded within an equipment.

NOTE 4: The agreed test signal may be formatted and may contain error detection and correction. Details of the test signal are to be supplied in the test report.

duplex filter: A device fitted internally or externally to a transmitter/receiver combination to allow simultaneous transmission and reception with a single antenna connection.

error of measurement (absolute): The result of a measurement minus the true value of the measurand.

error (relative): The ratio of an error to the true value.

estimated standard deviation: From a sample of n results of a measurement the estimated standard deviation is given by the formula:

$$\sigma = \sqrt{\frac{\sum_{i=1}^n (x_i - \bar{x})^2}{n-1}}$$

x_i being the i^{th} result of measurement ($i = 1, 2, 3, \dots, n$) and \bar{x} the arithmetic mean of the n results considered.

A practical form of this formula is:

$$\sigma = \sqrt{\frac{Y - \frac{X^2}{n}}{n-1}}$$

Where X is the sum of the measured values and Y is the sum of the squares of the measured values.

extreme test conditions: Conditions defined in terms of temperature and supply voltage. Tests are normally made with the extremes of temperature and voltage applied simultaneously. The upper and lower temperature limits are specified in the relevant testing standard. The test report states the actual temperatures measured.

error (of a measuring instrument): The indication of a measuring instrument minus the (conventional) true value.

free field: A field (wave or potential) which has a constant ratio between the electric and magnetic field intensities.

free Space: A region free of obstructions and characterized by the constitutive parameters of a vacuum.

impedance: A measure of the complex resistive and reactive attributes of a component in an alternating current circuit.

impedance (wave): The complex factor relating the transverse component of the electric field to the transverse component of the magnetic field at every point in any specified plane, for a given mode.

influence quantity: A quantity which is not the subject of the measurement but which influences the value of the quantity to be measured or the indications of the measuring instrument.

intermittent operation: Operation where manufacturer states the maximum time that the equipment is intended to transmit and the necessary standby period before repeating a transmit period.

isotropic radiator: A hypothetical, lossless antenna having equal radiation intensity in all directions.

limited Frequency Range: The limited frequency range is a specified smaller frequency range within the full frequency range over which the measurement is made.

NOTE 5: The details of the calculation of the limited frequency range are normally given in the relevant testing standard.

maximum permissible frequency deviation: The maximum value of frequency deviation stated for the relevant channel separation in the relevant testing standard.

measuring system: A complete set of measuring instruments and other equipment assembled to carry out a specified measurement task.

measurement repeatability: The closeness of the agreement between the results of successive measurements of the same measurand carried out subject to all the following conditions:

- the same method of measurement;
- the same observer;
- the same measuring instrument;
- the same location;
- the same conditions of use;
- repetition over a short period of time.

measurement reproducibility: The closeness of agreement between the results of measurements of the same measurand, where the individual measurements are carried out changing conditions such as:

- method of measurement;
- observer;
- measuring instrument;
- location;
- conditions of use;
- time.

measurand: A quantity subjected to measurement.

noise gradient of EUT: A function characterizing the relationship between the RF input signal level and the performance of the EUT, e.g., the SINAD of the AF output signal.

nominal frequency: One of the channel frequencies on which the equipment is designed to operate.

nominal mains voltage: The declared voltage or any of the declared voltages for which the equipment was designed.

normal test conditions: The conditions defined in terms of temperature, humidity and supply voltage stated in the relevant testing standard.

normal deviation: The frequency deviation for analogue signals which is equal to 12 % of the channel separation.

psophometric weighting network: As described in CCITT Recommendation O.41 [2].

polarization: For an electromagnetic wave, the figure traced as a function of time by the extremity of the electric vector at a fixed point in space.

quantity (measurable): An attribute of a phenomenon or a body which may be distinguished qualitatively and determined quantitatively.

rated audio output power: The maximum audio output power under normal test conditions, and at standard test modulations, as declared by the manufacturer.

rated radio frequency output power: The maximum carrier power under normal test conditions, as declared by the manufacturer.

shielded enclosure: A structure that protects its interior from the effects of an exterior electric or magnetic field, or conversely, protects the surrounding environment from the effect of an interior electric or magnetic field.

SINAD sensitivity: The minimum standard modulated carrier-signal input required to produce a specified SINAD ratio at the receiver output.

stochastic (random) variable: A variable whose value is not exactly known, but is characterized by a distribution or probability function, or a mean value and a standard deviation (e.g. a measurand and the related measurement uncertainty).

test load: The test load is a 50 Ω substantially non-reactive, non-radiating power attenuator which is capable of safely dissipating the power from the transmitter.

test modulation: The test modulating signal is a baseband signal which modulates a carrier and is dependent upon the type of EUT and also the measurement to be performed.

trigger device: A circuit or mechanism to trigger the oscilloscope timebase at the required instant. It may control the transmit function or inversely receive an appropriate command from the transmitter.

uncertainty (random): A component of the uncertainty of measurement which, in the course of a number of measurements of the same measurand, varies in an unpredictable way.

uncertainty (systematic): A component of the uncertainty of measurement which, in the course of a number of measurements of the same measurand remains constant or varies in a predictable way.

uncertainty (limits of uncertainty of a measuring instrument): The extreme values of uncertainty permitted by specifications, regulations etc. for a given measuring instrument.

NOTE 6: This term is also known as "tolerance".

uncertainty (standard): The representation of each individual uncertainty component that contributes to the overall measurement uncertainty by an estimated standard deviation is termed the standard uncertainty.

uncertainty (combined standard): The combined standard uncertainty of a measurement is calculated by combining the standard uncertainties for each of the individual contributions identified.

NOTE 7: This combination is carried out by applying the Root Sum of Squares (RSS) method under the assumption that all contributions are stochastic i.e. independent of each other.

uncertainty (expanded): The combined standard uncertainty is multiplied by a constant to give the expanded uncertainty limits.

upper specified AF limit: The maximum audio frequency of the audio pass-band. It is dependent on the channel separation.

wanted signal level: For conducted measurements Pa level of +6 dB μ V emf referred to the receiver input under normal test conditions. Under *extreme test conditions* the value is +12 dB μ V emf.

NOTE 8: For analogue measurements the wanted signal level has been chosen to be equal to the limit value of the measured usable sensitivity. For bit stream and message measurements the wanted signal has been chosen to be +3 dB above the limit value of measured usable sensitivity.

3.2 Symbols

For the purposes of this ETR, the following symbols apply:

β	$2\pi/\lambda$ (radians/m)
γ	incidence angle with ground plane ($^{\circ}$)
λ	wavelength (m)
ϕ_H	phase angle of reflection coefficient ($^{\circ}$)
η	120π Ohms - the intrinsic impedance of free space (Ω)
μ	permeability (H/m)
AF_R	antenna factor of the receive antenna (dB/m)
AF_T	antenna factor of the transmit antenna (dB/m)
AF_{TOT}	mutual coupling correction factor (dB)
c	calculated on the basis of given and measured data
C_{cross}	cross correlation coefficient
d	derived from a measuring equipment specification
$D(\theta, \phi)$	directivity of the source
d	distance between dipoles (m)
δ	skin depth (m)
d_1	an antenna or EUT aperture size (m)
d_2	an antenna or EUT aperture size (m)
d_{dir}	path length of the direct signal (m)
d_{refl}	path length of the reflected signal (m)
E	electric field intensity (V/m)
E_{DH}^{max}	calculated maximum electric field strength in the receiving antenna height scan from a half wavelength dipole with 1 pW of radiated power (for horizontal polarisation) (μ V/m)
E_{DV}^{max}	calculated maximum electric field strength in the receiving antenna height scan from a half wavelength dipole with 1 pW of radiated power (for vertical polarization) (μ V/m)
e_{ff}	antenna efficiency factor
ϕ	angle ($^{\circ}$)
Δf	bandwidth (Hz)
f	frequency (Hz)
$G(\theta, \phi)$	gain of the source (which is the source directivity multiplied by the antenna efficiency factor)
H	magnetic field intensity (A/m)
I_0	the (assumed constant) current (A)
I_m	the maximum current amplitude
k	$2\pi/\lambda$
k	a factor from Student's t distribution
k	Boltzmann's constant ($1,38 \times 10^{-23}$ Joules/ $^{\circ}$ Kelvin)
K	relative dielectric constant
l	the length of the infinitesimal dipole (m)
L	the overall length of the dipole (m)
l	the point on the dipole being considered (m)
m	measured
λ	wavelength (m)
p	power level value
$Pe^{(n)}$	probability of error n
$Pp^{(n)}$	probability of position n

P_r	antenna noise power (W)
P_{rec}	power received (W)
P_t	power transmitted (W)
θ	angle (°)
ρ	reflection coefficient
r	the distance to the field point (m)
ρ_g	reflection coefficient of the generator part of a connection
ρ_l	reflection coefficient of the load part of the connection
R_s	equivalent surface resistance (Ω)
σ	conductivity (S/m)
σ	standard deviation
r	indicates rectangular distribution
SNR_{b^*}	Signal to noise ratio at a specific BER
SNR_b	Signal to noise ratio per bit
T_A	antenna temperature (° Kelvin)
u	indicates U-distribution
U	the expanded uncertainty corresponding to a confidence level of x %: $U = k \times u_c$
u_c	the combined standard uncertainty
u_i	general type A standard uncertainty
u_{i01}	random uncertainty
u_j	general type B uncertainty
u_{j01}	reflectivity of absorbing material: EUT to the test antenna
u_{j02}	reflectivity of absorbing material: substitution or measuring antenna to the test antenna
u_{j03}	reflectivity of absorbing material: transmitting antenna to the receiving antenna
u_{j04}	mutual coupling: EUT to its images in the absorbing material
u_{j05}	mutual coupling: de-tuning effect of the absorbing material on the EUT
u_{j06}	mutual coupling: substitution, measuring or test antenna to its image in the absorbing material
u_{j07}	mutual coupling: transmitting or receiving antenna to its image in the absorbing material
u_{j08}	mutual coupling: amplitude effect of the test antenna on the EUT
u_{j09}	mutual coupling: de-tuning effect of the test antenna on the EUT
u_{j10}	mutual coupling: transmitting antenna to the receiving antenna
u_{j11}	mutual coupling: substitution or measuring antenna to the test antenna
u_{j12}	mutual coupling: interpolation of mutual coupling and mismatch loss correction factors
u_{j13}	mutual coupling: EUT to its image in the ground plane
u_{j14}	mutual coupling: substitution, measuring or test antenna to its image in the ground plane
u_{j15}	mutual coupling: transmitting or receiving antenna to its image in the ground plane
u_{j16}	range length
u_{j17}	correction: off boresight angle in the elevation plane
u_{j18}	correction: measurement distance
u_{j19}	cable factor
u_{j20}	position of the phase centre: within the EUT volume
u_{j21}	positioning of the phase centre: within the EUT over the axis of rotation of the turntable
u_{j22}	position of the phase centre: measuring, substitution, receiving, transmitting or test antenna
u_{j23}	position of the phase centre: LPDA
u_{j24}	Stripline: mutual coupling of the EUT to its images in the plates
u_{j25}	Stripline: mutual coupling of the 3-axis probe to its image in the plates
u_{j26}	Stripline: characteristic impedance
u_{j27}	Stripline: non-planar nature of the field distribution
u_{j28}	Stripline: field strength measurement as determined by the 3-axis probe
u_{j29}	Stripline: transform factor

u_{j30}	Stripline: interpolation of values for the transform factor
u_{j31}	Stripline: antenna factor of the monopole
u_{j32}	Stripline: correction factor for the size of the EUT
u_{j33}	Stripline: influence of site effects
u_{j34}	ambient effect
u_{j35}	mismatch: direct attenuation measurement
u_{j36}	mismatch: transmitting part
u_{j37}	mismatch: receiving part
u_{j38}	signal generator: absolute output level
u_{j39}	signal generator: output level stability
u_{j40}	insertion loss: attenuator
u_{j41}	insertion loss: cable
u_{j42}	insertion loss: adapter
u_{j43}	insertion loss: antenna balun
u_{j44}	antenna: antenna factor of the transmitting, receiving or measuring antenna
u_{j45}	antenna: gain of the test or substitution antenna
u_{j46}	antenna: tuning
u_{j47}	receiving device: absolute level
u_{j48}	receiving device: linearity
u_{j49}	receiving device: power measuring receiver
u_{j50}	EUT: influence of the ambient temperature on the ERP of the carrier
u_{j51}	EUT: influence of the ambient temperature on the spurious emission level
u_{j52}	EUT: degradation measurement
u_{j53}	EUT: influence of setting the power supply on the ERP of the carrier
u_{j54}	EUT: influence of setting the power supply on the spurious emission level
u_{j55}	EUT: mutual coupling to the power leads
u_{j56}	frequency counter: absolute reading
u_{j57}	frequency counter: estimating the average reading
u_{j58}	Salty man/Salty-lite: human simulation
u_{j59}	Salty man/Salty-lite: field enhancement and de-tuning of the EUT
u_{j60}	Test Fixture: effect on the EUT
u_{j61}	Test Fixture: climatic facility effect on the EUT
V_{direct}	received voltage for cables connected via an adapter (dB μ V/m)
V_{site}	received voltage for cables connected to the antennas (dB μ V/m)
W_0	radiated power density (W/m ²)

3.3 Abbreviations

For the purposes of this ETR, the following abbreviations apply:

AF	Audio Frequency
BER	Bit Error Ratio
CD	Citizen's Band
DM-0	A test modulation consisting of a signal representing an infinite series of "0" bits
DM-1	A test modulation consisting of a signal representing an infinite series of "1" bits
DM-2	A test modulation consisting of a signal representing a pseudorandom bit sequence of at least 511 bits in accordance with CCITT Recommendation O.153 [3].
D-M3	A test signal should be agreed between the testing authority and the manufacturer in the cases where it is not possible to measure a bit stream or if selective messages are used and are generated or decoded within an equipment

NOTE: The agreed test signal may be formatted and may contain error detection and correction. Details of the test signal are to be supplied in the test report.

emf	Electromotive force
EUT	Equipment Under Test
FSK	Frequency Shift Keying

GMSK	Gaussian Minimum Shift Keying
GSM	Global System for Mobile telecommunication (Pan European digital telecommunication system)
IF	Intermediate frequency
LPDA	Log Periodic Dipole Antenna
m	measured
NaCl	Sodium chloride
NSA	Normalized Site Attenuation
r	indicates rectangular distribution
RF	Radio Frequency
rms	root mean square
RSS	Root-Sum-of-the-Squares
TEM	Transverse Electro-Magnetic
u	indicates U-distribution
VSWR	Voltage Standing Wave Ratio

4 Introduction

4.1 Artificial human beings

There are several forms of artificial human beings currently used in radiated testing. The three most commonly used types are the saltwater column, the "Salty man" and "Salty-lite". The saltwater column has historically been used not only for testing body-worn devices e.g. paging receivers, but also for tests on maritime and other mobile equipment. It was the first in existence and is mainly used in measurements on body-worn equipment operating below 50 MHz. At higher frequencies, many tests are currently performed using two types of Salty man (basically saltwater filled plastic cylinders of the height of an average adult) and artificial human bodies, in which some attempt has been made to incorporate human details, e.g. distinct arms, legs and torso.

4.1.1 Saltwater column

A saltwater column comprises a plastic cylinder of side wall thickness 0,005 m, overall height 1,5 m and of inside diameter typically 0,01 m filled with a saline solution whose concentration of salt (NaCl) is 9,0 grams per litre of distilled water (see figure 1). The saltwater column has been used with the EUT either fixed to the side of the column (to simulate belt worn or breast pocket worn devices) or mounted on a hinged metal mounting bracket on the top metal cap. This latter enables an EUT to be oriented at various angles during measurements.

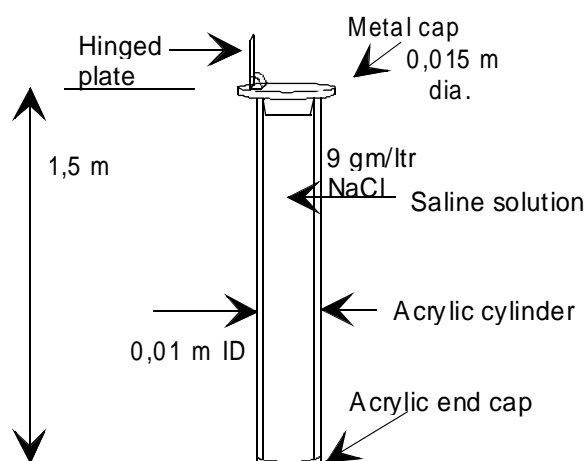

Figure 1: Typical saltwater column

No theoretical or experimental data concerning the saltwater column has been found and due to its obvious dissimilarity with the human body, and the lack of data supporting its usage, it is recommended that the saltwater column should not be used for body-worn equipment tests. The following discussions are therefore limited to the merits of Salty man and "Salty-lite" and the recommended frequency limitations of their use on free-field test site.

4.1.2 Salty man

A "Salty man", illustrated in figure 2a, comprises a cast acrylic cylinder of 0,305 m outside diameter with acrylic caps at both ends. It is 1,7 m in length with side wall thickness of 4,8 mm and the whole is filled with a saline solution whose concentration is 1,49 grams of salt per litre of distilled water. Figure 2a illustrates the original design of a Salty man as detailed in IEC 489-6 [8] Appendix H.

4.1.3 "Salty-lite"

"Salty-lite" is shown in figure 2b and is a much lighter version of the Salty man (approximately 61,5 kg against 125 kg) which therefore makes it easier to handle and transport.

Salty-lite comprises two concentric cast acrylic cylinders, the outer one having an outside diameter of 0,305 m whilst the inner cylinder has an outside diameter of 0,225 m. The outer cylinder is 1,32 m in length whilst the inner one measures 1,52 m. The difference in length is used to form an air-filled head. Only the space between the two cylinders is filled with saline solution which, in early versions, had a similar concentration of salt as the Salty man (1,49 grams of salt per litre of distilled water). However, "Use of Simulated Human Bodies in pager receiver sensitivity measurements" [9] revealed several resonances are evident at this concentration, and experimental and theoretical work [1] showed that these resonances could be damped out by using a concentration of 4 grams of salt per litre of distilled water. This is the currently recommended concentration and all discussion of Salty-lite's electrical performance given in clauses 4 and 5 assume this more concentrated salt solution.

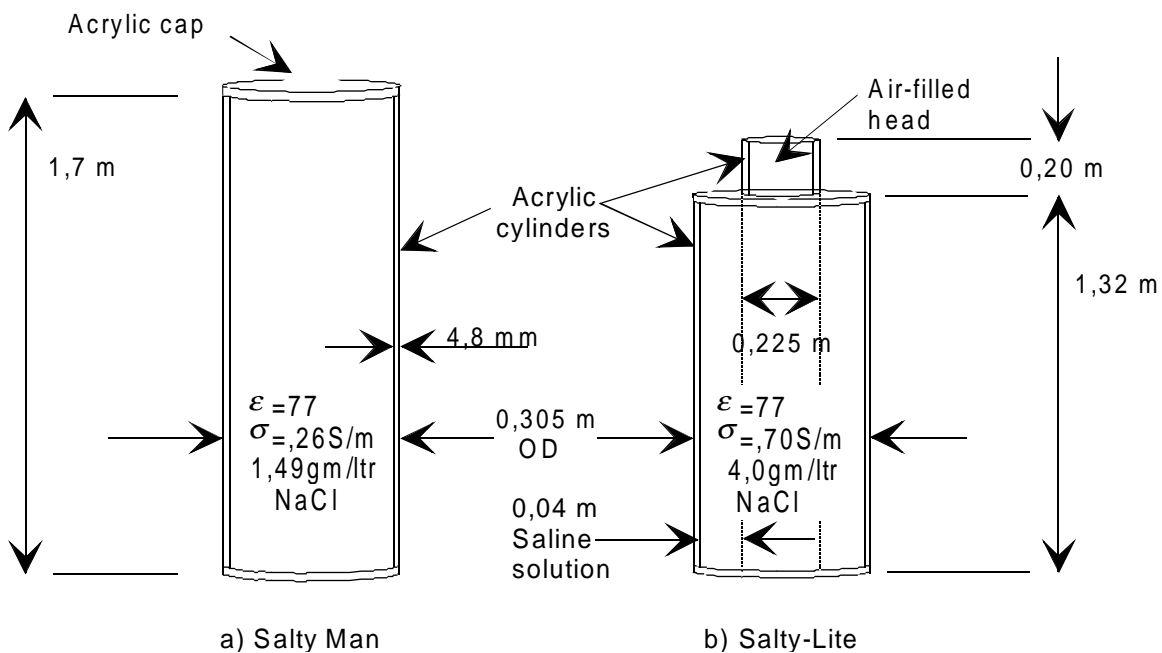

Figure 2: The two types of Salty man.

4.1.4 Other salties

Various other artificial human forms are currently under development and refinement - a typical form of artificial being is shown in figure 3. This type comprises hollow plastic tubes which can be filled with a saline solution or gel and can also be disassembled. Various specific attachments are available for these forms, including artificial heads and arms in different configurations.

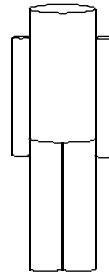

Figure 3: Artificial human being made from hollow plastic pipes

4.2 Simulation of the human form

The degree to which any of the human forms, particularly the Salty man and Salty-lite, simulate the human body, has been the subject of extensive testing. In terms of the electrical behaviour of the human body, an upright human behaves in an electrically similar way to a lossy wire antenna for frequencies above 150 MHz.

The upright human also possesses resonances to vertically polarized fields in the region of 40 to 80 MHz, the precise frequency depending on the type of ground they are standing on. This so-called "whole body" resonance to vertically polarized fields is reasonably well simulated by Salty man, although at its greatest difference, Salty man enhances typical human gain-averaged performance by 3 dB [10].

NOTE: The term "whole body" derives from the frequency of the effect which corresponds to the fundamental resonant length of the overall body.

This maximum difference tends to occur around the peak of the whole-body resonance i.e. at about 60 MHz over average earth ground.

The frequency of the whole body resonance peak changes significantly with the type of ground. Where a metallic ground plane is used, imaging results in halving (approximately) of the free-space resonance frequency to around 40 MHz, whilst for free space it is around 70 MHz.

For frequencies below about 250 MHz, vertically polarized incident fields are enhanced more than horizontally polarized fields largely due to the whole body resonance. Above about 300 MHz, the enhancement is greater for horizontal polarization than for vertical polarization. As a result of this magnetic field enhancement/electric field reduction, the performance of equipment designed for body wearing can vary significantly between free-space and body-mounted conditions.

In terms of theoretical analysis, the human body can be accurately modelled as infinitely long cylinders filled with saline water for all frequencies for horizontal polarization and all frequencies above the resonance for vertical polarization. This was the origin of the idea behind saltwater filled columns for simulation of the human body.

4.3 Test conditions

The provision of realistic test conditions for Salty man/Salty-lite is extremely difficult. In everyday use of a body-worn equipment, a human being will operate the equipment over a variety of ground types, none of which influences performance in the same way as those provided during testing in either an anechoic chamber or on a perfectly reflecting ground plane site. Specifically, the distribution of the illuminating fields over the length of the Salty man/Salty-lite (when used in receiver tests) varies fundamentally with ground type. Whereas the ideal anechoic chamber provides a slowly varying amplitude distribution (consistent with the vertical plane radiation pattern of the transmitting antenna) and a phase distribution entirely dependent on the path length geometry (see figure 4), an open area test site/anechoic chamber with a ground plane can, in contrast, provide a wildly varying field distribution. By virtue of the phase of the reflected signal on this ground plane type of site, horizontally and vertically polarized signals are affected differently. Figure 5 shows the distribution of amplitude and phase for a vertically polarized electric field over the length of Salty man/Salty-lite for a typical testing range length of 3 m over a ground plane. The height of the test antenna has been optimized for a chest worn equipment, assumed to be mounted 1,5 m above the base of the Salty man.

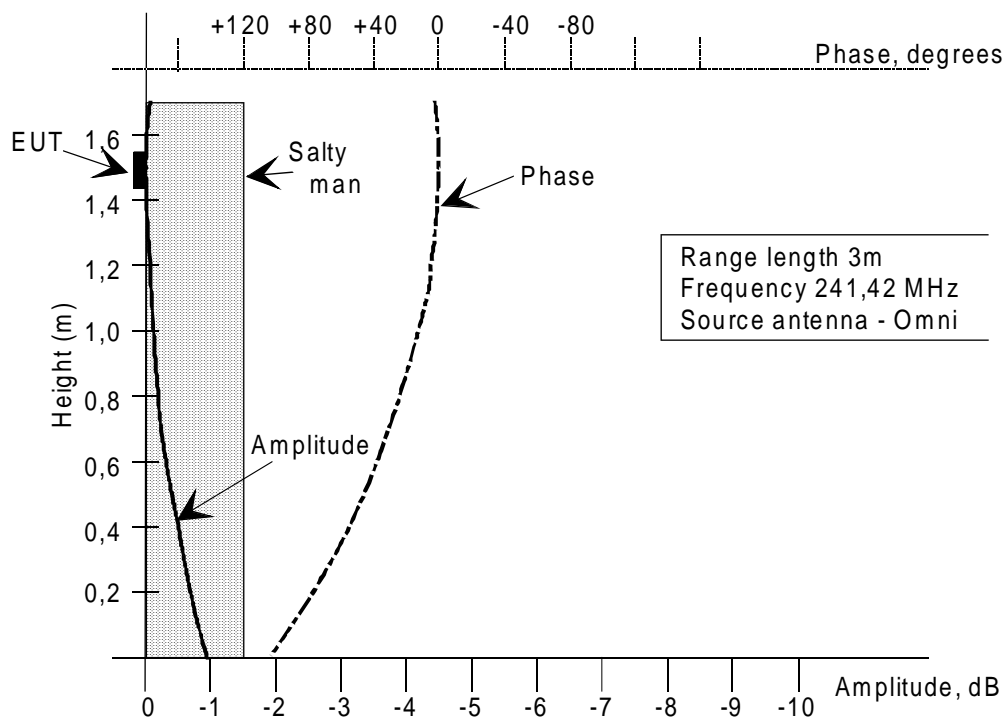

Figure 4: Amplitude and phase distribution along the Salty man over an absorptive ground

The figure shows that a deep null in the amplitude of the illuminating electric field occurs at a height of approximately 0,7 m above the base of the Salty man. Additionally, the phase of the illuminating field over the length of the Salty man is far from uniform. One has to ask whether the results from tests carried out on the type of facility are truly representative of the real-life performance. On the plus side, it can be seen from figure 5 that in the near vicinity of the EUT the amplitude and phase of the electric field is reasonably constant but this may not be sufficient for test purposes.

The parameters for determining figure 5 have been selected as a typical example; a test antenna height of 1,5 m giving a field maximum at chest height (also 1,5 m) at a range length of 3 m. For the example frequency of 241,42 MHz, there is no other test antenna height (assuming 1 m to 4 m available height variation) which will produce a peak at chest height. Therefore only one null appears on the Salty man/Salty-lite. However, as the frequency increases more nulls appear.

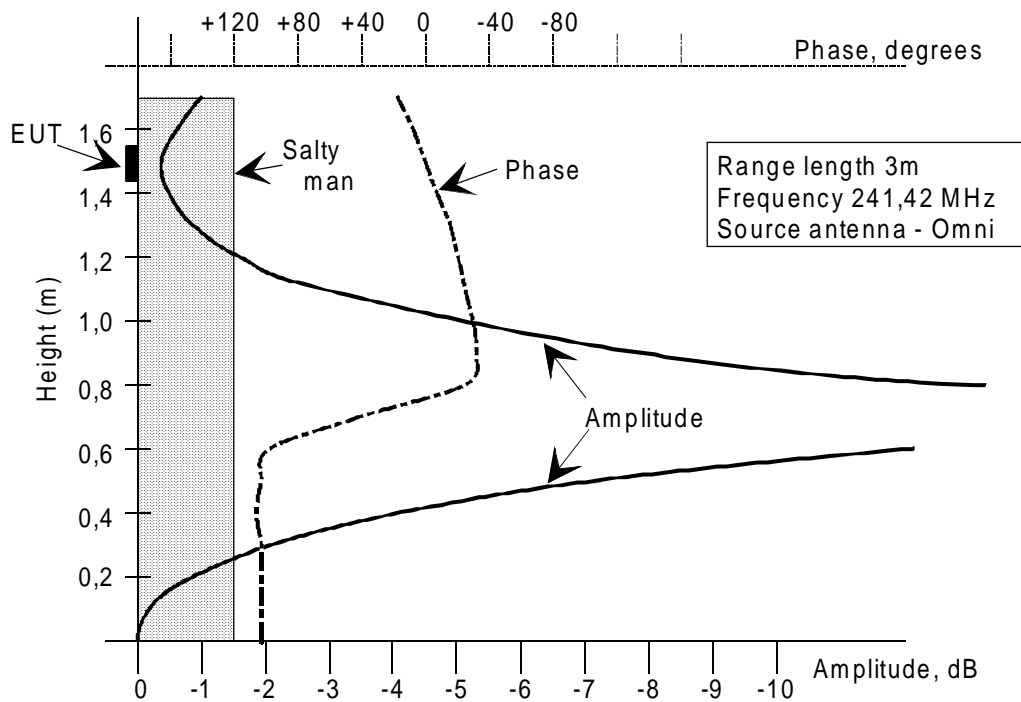

Figure 5: Amplitude and phase distribution along the Salty man over a reflective ground

For example, above 254,2 MHz there will be at least two peaks to choose from for the maximum signal (and hence two nulls in the illumination over Salty man/Salty-lite), above 381,4 MHz at least three peaks (and three nulls), etc., up to above 889,9 MHz where there will be at least seven peaks to choose from with their seven associated nulls. Since mutual coupling and extraneous reflections can play a significant role in determining the magnitude of these peaks it cannot be ruled out that, in the worst case, all of these theoretically possible peaks and nulls will be present during testing. The value of a test result taken in this worst case of multiple nulling over the Salty man/Salty-lite is difficult to assess.

Conversely, if one imposed the conditions that:

- no null should appear in the illumination across Salty man/Salty-lite and;
- the maximum amplitude variation should not exceed, say, 5 dB (taken for illustration only).

Then a 3 m range could only be used for frequencies below about 38,5 MHz and a 10 m range length below about 74,1 MHz.

Contrast this testing environment generated on a ground-reflecting range, to that provided by an ideal anechoic chamber offering the same range length (shown in figure 4). Here, the illuminating electric field is reasonably constant in both amplitude and phase along the entire length of the Salty man the variations being dependent on the radiation pattern of the test antenna in the vertical plane and the overall geometry for amplitude and phase respectively.

5 Uncertainty contributions specific to Salty man/Salty-lite

5.1 Comparison between average humans and Salties

Comparative measurements between humans and the two types of Salty man over average ground [1], have revealed that above 86 MHz, the two simulated forms are fairly accurate representations, their magnetic field strengths being within 1,7 dB of the measured human average. No figures are available for the hollow pipe version (shown in figure 3).

Measured data for the sensitivities of belt-worn pagers when worn by human beings, taken from numerous sources are in general agreement with each other. For example, at about 153 MHz, the spread of sensitivities is typically ± 2 dB in the direction the pager faces, ± 3 dB in the opposite direction with a level difference of around 8,5 dB. Within 1 dB to 2 dB, all sources agree with these figures.

The degree to which pager sensitivity measured on the Salty man at this frequency matches these figures is somewhat more variable. Some sources, "Use of Simulated Human Bodies in pager receiver sensitivity measurements" [9], suggest an excellent fit to within 2 dB or 3 dB of the average human performance, whilst others show variations of up to 6,4 dB. Salty-lite is shown, "Use of Simulated Human Bodies in pager receiver sensitivity measurements" [9], to be at considerable variance with the human average for all angles in the rear-facing 90° sector, with differences of up to 12 dB.

At 465,970 MHz, the spread of belt-worn pager sensitivities, when worn by human beings, is more exaggerated however, with ± 6 dB variations in front and back coverage, with the relative front to back level being about 15 dB. Again, however, there is considerable difference in the results from the different sources for the performance when mounted on the Salty man. All show considerable variations from the human average figures, and typically, the variations are ± 8 dB with maximum values up to 16 dB. However, in one of the reference sources, the amplitude distribution from the source antenna was found to possess a null at the pager height (1,4 m). The variability at 929 MHz is similar to that at 465,970 MHz.

Neither of these simulated human beings can be used in isolation for testing - they can only be used in conjunction with a true test site e.g. anechoic chambers (both with and without a ground plane) and open area test sites. Use in a stripline is not recommended due mainly to the size limitations imposed on any test item i.e. the maximum dimension of the item should be less than a sixth of a wavelength. Use in an imperfect ground plane environment, for example where earth ground is used, has been shown to be possible [10] but consideration of such a type of test site is beyond the scope of this ETR.

5.2 Uncertainties associated with the use of Salty man and Salty-lite

The degree to which the artificial human forms can accurately simulate a human being is a major source of concern in any pager sensitivity measurement. The overriding aspect is to what extent measured performance, principally sensitivity for pagers, is distorted by the differences between either of the salties and the human body. In [10], it is stated that the gain-averaged field sensitivities measured using Salty man and Salty-lite are within 2 dB of the average of people in a standard pose, whereas the variation produced by an anthropometrically diverse group of adults was within $\pm 0,8$ dB at VHF and $\pm 0,6$ dB at UHF. As such, the ability of the artificial forms to simulate humans would appear quite good.

Further uncertainties in measurements come from uneven distribution of salt in the saline solution. The salt needs to be well mixed with the distilled water and not in such a state as might allow the salt crystals to settle either on the side walls of the cylinders or at the bottom. Any salt settling out will affect both the conductivity and the permittivity of the solution, resulting in measurement uncertainties. This is a known problem where saline gel has been used - in one case, the gel having turned almost to pure water within the time span of 12 months.

Any inaccuracy in the spacing of a pager away from a Salty is known to produce measurement errors since the magnetic field strength is strongly dependant on the spacing. It is consequently an essential part of any pager tested on a Salty that no gap be allowed between the pager and the acrylic column.

The accuracy of determining pager sensitivity thresholds during testing is dependent on many factors, amongst which are the type of modulation used, error correction (if used) and the step change used to vary the signal amplitudes during testing. These are further sources of measurement uncertainty.

Temperature variations of the saline solution can also result in changes to the conductivity and permittivity. These effects tend to reveal themselves as changes to the depth of the rear facing null in the radiation patterns of the test items. However, it is apparent [10], that the gain-averaging used in average sensitivity measurements tends to make the final results largely independent of the null depth change (e.g. whilst an ambient temperature change of 35 °C produced a null depth change of 4,1 dB, the gain-averaged sensitivity which resulted only showed a 0,1 dB change). It is none the less recommended that records of the temperature of the salt water be made immediately before testing.

On top of all these factors will be the uncertainties of the test site on which the measurements are taken.

5.3 Measurement considerations for Salty man and Salty-lite

Salty man and Salty-lite show differences in their electrical behaviour as far as the frequency range of interest (above 30 MHz) is concerned.

Ground conditions seriously affect the electrical characteristics for both types of Salty. Placed on a perfectly conducting surface, an image is created in the ground, nominally doubling the effective length of the Salty and, as a result, halving the free space whole body resonance frequency. Placed on a perfectly absorbing surface, no such increase in effective length occurs and the free-space resonance frequency is maintained. Using average earth ground will give a resonance frequency somewhere between these two extremes.

5.3.1 Frequency ranges

As far as tests using Salty man and Salty-lite are concerned, This ETR only deals with free-field test site offering either a perfectly reflecting ground plane (i.e. anechoic chambers with ground planes or open area test sites) or a completely absorptive environment (i.e. fully anechoic chambers). As a result, the published data [10], which is mainly on performance above average ground, has to be extrapolated in some cases to gauge likely performance over the two extremes of surfaces considered here.

The whole-body resonance of Salty-lite [10] is higher (around 90 MHz above average ground) than for Salty man as a result of its reduced height (1,52 m against 1,7 m). Both Salty man and Salty-lite produce "body enhancement" characteristics although below 100 MHz, when placed on average earth ground, that produced by Salty-lite falls off, with frequency, far quicker than for a real human. Assuming the rate of fall-off below the whole-body resonance frequency is approximately constant irrespective of the type of ground surface (as in the case of Salty man), and estimating the rise in resonance frequency (relative to average ground) when placed in an anechoic chamber, the lowest frequency for which Salty-lite can be used in such a chamber should be taken as 100 MHz. On a ground reflection site (i.e. open area test sites or anechoic chamber with a ground plane) this lowest frequency of use should be taken as 70 MHz.

Salty man is more fully documented [10] but is somewhat more complex. Over average ground, Salty man can be regarded as a reasonable simulation of an average human (i.e. within 2 dB maximum variation) for all frequencies from 30 MHz to 50 MHz and from 85 MHz to 1 000 MHz and, with somewhat less agreement, from 50 MHz to 85 MHz (i.e. within 3 dB).

Of the two types of Salty, Salty man is the more accurate simulation, particularly in replicating the whole-body resonance to vertically polarized fields. Generally, for an adult human, this occurs in the 40 MHz to 80 MHz range (depending on ground conditions) and is well approximated by Salty man's 40 MHz to 70 MHz resonance. The simulation by Salty-lite is poor by comparison - the raising of the frequency range of the whole-body resonance (to approximately 60 MHz to 100 MHz) being a direct effect of its shortened height compared to Salty man.

5.3.2 Uncertainties of use

Arguably, on the basis of accuracy to within 3 dB, one could reduce the lowest usable frequency for Salty-lite and therefore offer an alternative to Salty man for these lower frequencies. However, whereas Salty man enhances further the human body effect, Salty-lite reduces the effect - there being a potential difference of up to 6 dB between results taken from the two. The recommendation is therefore for only Salty man to be used as the simulated human in the 30 MHz to 100 MHz band for anechoic chambers and 30 MHz to 70 MHz for anechoic chambers with ground planes and open area test sites. In this way the spread of results from test houses in these bands should be greatly reduced.

At around 150 MHz above average ground, the performance of Salty man and Salty-lite appear to be virtually identical although for frequencies above 150 MHz, the fit of Salty-lite's performance to that of an average adult human [10] seems marginally better than Salty man. Salty-lite is therefore recommended for use above 150 MHz.

5.3.3 Conclusion

Reviewing the relative performances of the two types of Salty, it is possible to derive a final usage recommendation as follows. Salty man is chosen as the reference artificial human being in the band 30 - 150 MHz, whilst Salty-lite is taken as the reference in the band 150 MHz to 1 000 MHz. Optionally, Salty man can be used in the higher band, but under the penalty of increased measurement uncertainty. Equally, Salty-lite could be used in the bands 70 MHz to 150 MHz on a ground reflection site and 100 MHz to 150 MHz in an anechoic chamber, but again increased measurement uncertainty will result.

Table 1 shows the recommended usage of Salty man and Salty-lite for body-worn equipment.

Table 1: Recommended frequency bands of usage for Salty man and Salty-lite

Type of test facility	Recommended and optional frequency bands of usage	
anechoic chamber	Recommended	
	30 MHz to 150 MHz	150 MHz to 1 000 MHz
	Salty man	Salty-lite
	Optional	
	100 MHz to 150 MHz	150 MHz to 1 000 MHz
	Salty-Lite	Salty man
Open area test site or an anechoic chamber with a ground plane	Recommended	
	30 MHz to 150 MHz	150 MHz to 1 000 MHz
	Salty man	Salty-lite
	Optional	
	70 MHz to 150 MHz	150 MHz to 1 000 MHz
	Salty-lite	Salty man

6 Verification procedure for the Salty man and Salty-lite

In the following verification procedure the measured parameter is the conductivity of the saline solution. The electrical behaviour of the Salty man/Salty-lite is fundamentally dependant on the salinity of the solution within the column. Too little salinity in Salty-lite, for example, results in additional resonances and too much salinity is unrepresentative of the human form. Any change in salinity is not easily detected by the measurement of dielectric constant of the solution as only small changes in dielectric constant result from wide variation in salinity and temperature. Conversely, the conductivity of a salt solution exhibits strong variation with salinity and temperature. As a result, measurement of the conductivity can more easily reveal faults or irregularities. Therefore in the following conductivity of the saline solution is measured.

6.1 Definition

Conductivity is defined in [4] as "the ratio of the current density in a conductor to the electric field causing the current to flow. It is the conductance between opposite faces of a cube of the material of one metre edge". It is the reciprocal of resistivity and the units are $\Omega^{-1}m^{-1}$.

6.2 Overview of the verification procedure

For verification purposes, the range of tests which can be performed on any of the artificial human forms is very limited. The tests are restricted to mechanical and visual inspections of the overall assembly and measurement of the conductivity of the saline solution. Optionally, the latter test can be avoided if a fresh saline solution is made up at frequent intervals.

The conductivity of a saline solution can be calculated from [10]:

$$\sigma = \sigma_n [(1 - 0,01962(25-T)) + (8,08 \times 10^{-5}(25-T)^2) + (N \times 10^{-5}(T-25) \times A)]$$

Where:

σ is the conductivity (Siemens/m);

T is the temperature (°C);

$A = 3,02 + 3,922 \times (25-T) + N \times (1,721 - (0,6584 \times (25-T)))$;

$N = 0,01707 \times S + 1,205 \times 10^{-5} \times S^2 + 4,058 \times 10^{-9} \times S^3$;

S is the salinity of the solution (grams of salt/litre of water);

σ_n is the conductivity at 25°C given by:

$$\sigma_n = 10,394 \times N - 2,3776 \times N^2 + 0,68258 \times N^3 - 0,13538 \times N^4 + 0,010086 \times N^5 \text{ (Siemens/m).}$$

Calculated values of the variation of conductivity against temperature for the 3 concentrations of saline solution (1,49 gm/litre, 4 gm/litre and 9 gm/litre) are given in table 2. The same information is shown in graphical form in figure 6.

Table 2: The conductivity of saline water against temperature and concentration of salt

Temp (°C)	Salt concentration			Temp (°C)	Salt concentration		
	1,49 gm/l	4,0 gm/l	9,0 gm/l		1,49 gm/l	4,0 gm/l	9,0 gm/l
-10	0,108	0,286	0,629	16	0,218	0,581	1,288
-8	0,116	0,307	0,674	18	0,228	0,607	1,345
-6	0,123	0,327	0,72	20	0,238	0,633	1,403
-4	0,131	0,348	0,767	22	0,248	0,66	1,462
-2	0,139	0,369	0,815	24	0,258	0,687	1,522
0	0,147	0,391	0,864	26	0,268	0,715	1,583
2	0,155	0,413	0,913	28	0,279	0,743	1,645
4	0,164	0,436	0,964	30	0,289	0,77	1,708
6	0,173	0,46	1,016	32	0,3	0,8	1,772
8	0,181	0,483	1,068	34	0,311	0,829	1,836
10	0,190	0,507	1,122	36	0,322	0,859	1,902
12	0,2	0,531	1,176	38	0,334	0,889	1,968
14	0,209	0,556	1,232	40	0,345	0,919	2,036

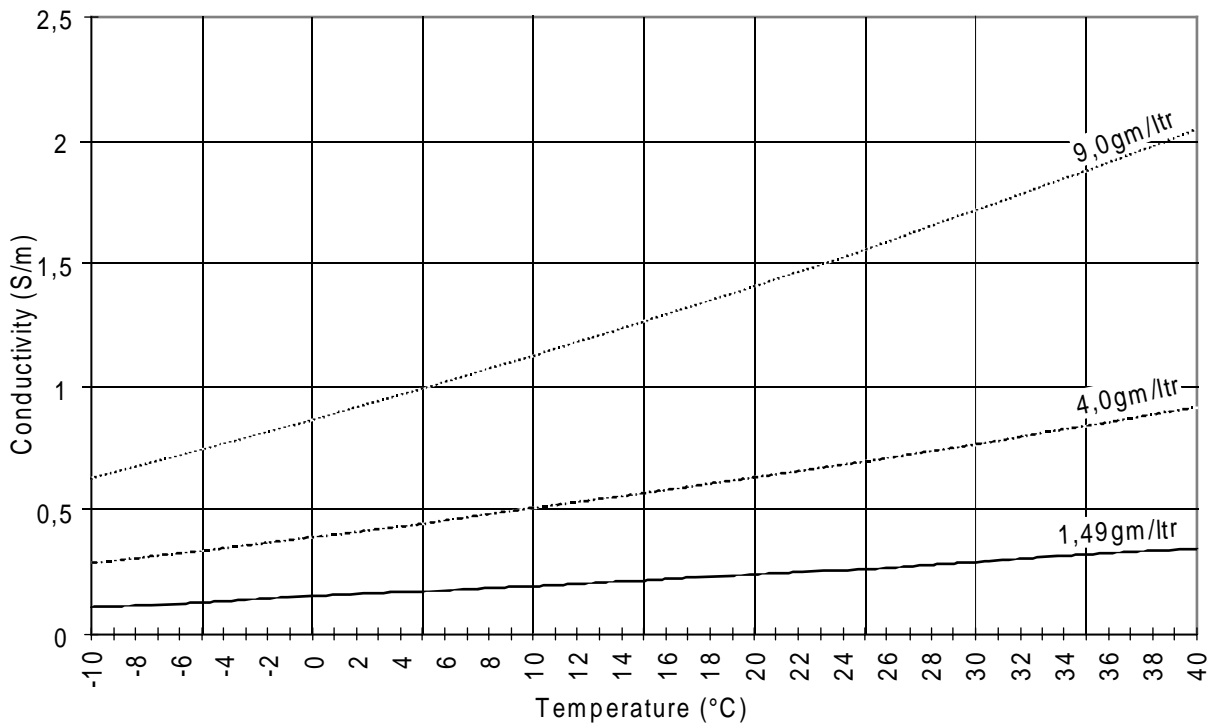

Figure 6: Variation of conductivity of various concentrations of saline solutions with temperature

6.2.1 Apparatus required

DC conductivity meter.

6.2.2 Site preparation

No special preparation of the site is required.

6.2.3 Measurement configuration

The Salty man/Salty-lite should be placed upright and filled with a saline solution with the specified concentration of grams of salt per litre of water. The solution should be thoroughly stirred to ensure the salt completely dissolves and the saline solution is uniformly distributed.

6.2.4 What to record

The ambient temperature at which the verification is carried out should be recorded, along with the humidity.

The conductivity of the saline solution should be recorded at a number of heights within the column.

Details of the conductivity meter (i.e. manufacturer, model type number and serial number) should also be recorded.

6.3 Verification procedure

- 1) The artificial human form should be stood on a flat surface with sufficient space around it that a full 360° inspection can be carried out.
- 2) A visual inspection of all the surfaces should be carried out, looking for surface abrasions, cracks, sources of leakage, etc. If the saline solution does not completely fill the cylinder, the level should be topped up with the appropriate concentration of salt water. Any crystalline surface deposits observed during the inspection might indicate cracking in the plastic cylinder. In serious cases this might dictate complete replacement of the cylinder. Should the cause be spillage, then these crystalline deposits, along with any other type of deposit should be removed.

NOTE 1: Steps 3, 4 and 5 may be omitted if the saline solution has been mixed within the seven days prior to verification testing.

- 3) The top lid of the artificial human forms should be removed to reveal the saline solution.
- 4) The dc conductivity meter should be immersed into the saline solution to measure the conductivity at a point just below the surface level. The value of conductivity should be recorded in the results sheet (table 3).

NOTE 2: If the measured conductivity differs by more than 10 % from the figure calculated/tabulated/shown in subclause 6.2 for the ambient temperature, the saline solution should be thoroughly stirred and step 4 repeated. If the conductivity remains in error by more than 10 %, a new salt water solution should be prepared and used to refill the artificial human.

- 5) Measurements of the conductivity should be made at the middle and bottom of the cylinder, so that the full depth is covered. All measured values should be recorded in the results sheet (table 3).

NOTE 3: If the variation in measured conductivity's is greater than 10 %, the saline solution should be thoroughly stirred and steps 4 and 5 repeated.

6.4 Processing the results of the verification procedure

The results of the conductivity measurements do not need any special processing.

6.4.1 Report format

The conductivity measurements should be tabulated on the results sheet, a typical example of which is given in table 3.

Table 3: Results sheet for the verification procedure for Salty man and Salty-lite

Salty man/Salty-lite verification procedure results sheet			PAGE 1 of 1
Date:.....		Temperature:	Humidity:
Position of Conductivity probe	Measured Conductivity	Theoretical Conductivity	Difference %
Top			
Middle			
Bottom			
Conductivity meter:		Manufacturer:	
Model Type number:		Serial number:	

6.5 Calculation of measurement uncertainty

6.5.1 Introduction

The basis of the above verification procedure is that a measurement of the conductivity of the saline solution filling the Salty man/Salty-lite is adequate, by itself, for determining the serviceability of the device as an accurate simulation of the human body. Therefore, the only uncertainty components involved in this procedure are those related to the measurement of the ambient temperature and the conductivity of the solution.

6.5.2 Discussion of uncertainty contributions

The only sources of uncertainty in this procedure are those associated with the uncertainty of measuring the ambient temperature and the conductivity of the saline solution.

Given that the acceptable discrepancies between measured and calculated conductivity values in this procedure are quite broad ($\pm 10\%$), it is concluded that, provided the temperature measuring device and the conductivity meter possess valid calibration certificates, the magnitudes of their associated uncertainties are insignificant in this verification procedure.

6.5.3 Uncertainty contribution, actual measurement

Not relevant.

7 Test methods

7.1 Introduction

Whichever type of test facility is used for the tests involving the salty device i.e. anechoic chamber, anechoic chamber with a ground plane or open area test site, the range length should be adequate to allow for testing in the far-field of the EUT i.e. the measurement distance should be equal to or exceed:

$$\frac{2(d_1 + d_2)^2}{\lambda}$$

where:

- d_1 is the largest dimension of the EUT/dipole after substitution (m);
- d_2 is the largest dimension of the test antenna (m);
- λ is the test frequency wavelength (m).

It should be noted that in the field measurement part for receiver tests, where both test and measuring antennas are half wavelength dipoles, this minimum range length for far-field testing would be:

$$2\lambda$$

It should be stated in the test report when either of these conditions is not met so that the additional measurement uncertainty can be incorporated into the results.

For a fully anechoic chamber, no part of the volume of the EUT should, at any angle of rotation, fall outside the "quiet zone" of the chamber at the nominal frequency of test. Where this condition cannot be met, the measurement should not be carried out.

NOTE: The "quiet zone" is a volume within the chamber in which a specified performance has either been proven by test, or is guaranteed by the designer/manufacture. The specified performance is usually the reflectivity of the absorbing panels or a directly related parameter (e.g. signal uniformity in amplitude and phase). It should be noted however that the defining levels of the quiet zone tend to vary.

For anechoic test sites of any description, the restriction that no part of any antenna or EUT should come within 1 m of any part of the absorbing panels should be applied at all times throughout all procedures (this is to avoid "electrical loading"). For the EUT this condition needs to be satisfied for all angles of rotation. Further, measurements should not be carried out if the reflectivity of the absorbing material within the chamber is worse than -5 dB at the frequency of test. For ground reflection test sites i.e. anechoic chambers with ground planes or open area test sites, a full height scanning capability, i.e. 1 m to 4 m should be available. Where any of these conditions cannot be met, the measurement should not be carried out.

7.1.1 Site preparation

The cables for both ends of the test site should be routed horizontally away from the testing area (along the line joining the test antenna support/mast at one end to the centre of the turntable at the other) for a minimum of 2 m unless, as in the case of anechoic chambers (both with and without ground planes) the back wall is reached. They should then be allowed to drop vertically towards the floor and out through the screen (or ground plane) to the test equipment. These cables should be dressed with ferrite beads, spaced 0,15 m apart for their entire lengths above the screen (or ground plane). The cables, their routing and dressing should be identical to the verification set-up.

NOTE: Where a cable drum is incorporated with the antenna mast, the routing requirement and ferrite beading of the cables may be impossible to comply with. In such cases increased measurement uncertainty results.

Calibration data for items of test equipment used should be available and valid. For the test and substitution or measuring antennas, this data should include antenna factor (or gain relative to an isotropic radiator) against frequency. Also the VSWR of the substitution or measuring antenna should be known.

The calibration data on all cables and attenuators used should include insertion loss and VSWR throughout the entire frequency range of the tests. All VSWR and insertion loss figures should be recorded in the log book results sheet for the specific test.

Where correction factors or tables are required, these should be immediately available.

For all items of test equipment, the maximum errors they exhibit should be known along with the distribution of the error, e.g.:

- cable loss: $\pm 0,5$ dB with a rectangular distribution;
- measuring receiver: 1,0 dB (standard deviation) signal level accuracy with a Gaussian error distribution.

At the start of each day, system checks should be made on the test equipment used in the test facility. The following checking procedures, as a minimum requirement, should be carried out.

- 1) All items of test equipment requiring electrical supplies should be connected to their power sources, switched on and allowed adequate time to stabilize, as recommended by the manufacturers. Where a stabilization period is not given by the manufacturer, 30 minutes should be allowed. After this time period those items of test equipment which possess the facility should have their self test/self calibration procedures performed.
- 2) A signal generator should be connected to the existing cabling at the turntable end. The other end of this cable should be connected via a calibrated coaxial cable/10 dB attenuator/adaptor/10 dB attenuator/calibrated coaxial cable combination to existing cabling at the other end of the test site. This existing cable should be connected to a receiving device. Where the use of a cable is impractical due to the arrangements at the test site, bicones or other suitable antennas could be connected at both ends as appropriate. The signal generator should be scanned across the appropriate frequency range and the response of the receiving device noted. It should be compared with previous tests carried out under similar conditions. Any anomalies should be investigated.

7.1.2 Preparation of the EUT

The manufacturer should supply information about the EUT covering the operating frequency, polarization, supply voltage(s) and the reference face. Additional information, specific to the type of EUT should include, where relevant, carrier power, channel spacing, whether different operating modes are available (e.g. high and low power modes) and if operation is continuous or is subject to a maximum test duty cycle (e.g. one minute on, four minutes off).

Where necessary, a mounting bracket of minimal size should be available for mounting the EUT on the Salty man/Salty-lite. This bracket should be made from low conductivity, low relative dielectric constant (i.e. less than 1,5) material(s) such as expanded polystyrene, balsa wood, etc.

The presence of the cables supplying power can affect the measured performance of the EUT. For this reason, attempts should be made to make them "transparent" as far as the testing is concerned. This can be achieved by routing them by the shortest possible paths down to, and out from, the floor screen (or ground plane). Additionally, where possible, leads should be twisted together and loaded with ferrite beads at 0,15 m spacing.

7.1.3 Standard antennas

In the frequency band 30 MHz to 1 000 MHz, except where stipulated, both test and substitution or measuring antennas should be tuned half-wavelength dipoles (constructed as detailed in ANSI C63.5 [1]) aligned for the same polarization.

NOTE: Due to size constraints a shortened dipole is used over part of this frequency band. For uniformity of procedures across open area test sites and both types of anechoic chamber, a shortened dipole is used from 30 MHz up to 80 MHz. At all these frequencies the 80 MHz arm length (0,889 m) is used, attached to the 20 to 65 MHz balun for all test frequencies from 30 MHz to 65 MHz inclusive and to the 65 MHz to 180 MHz balun for 65 MHz to 80 MHz. Tuned half wavelength dipoles, attached to their matching baluns are used for all frequencies in the band 80 MHz to 1000 MHz inclusive. Table 4 details dipole arm lengths (as measured from the centre of the balun block) and balun type against frequency. Where the test frequency does not correspond to a set frequency in the table, the arm length to be used should be determined by linear interpolation between the closest set values.

Table 4: Dipole arm length and balun type against frequency

Frequency (MHz)	Dipole arm length (m)	Balun type	Frequency (MHz)	Dipole arm length (m)	Balun type	
30	0,889	20 MHz to 65 MHz	160	0,440	65 MHz to 180 MHz	
35	0,889		180	0,391		
40	0,889		200	0,352	180 MHz to 400 MHz	
45	0,889		250	0,283		
50	0,889		300	0,235		
60	0,889		65 MHz to 180 MHz	400	0,175	400 MHz to 1 000 MHz
70	0,889			500	0,143	
80	0,889	600		0,117		
90	0,791	700		0,102		
100	0,714	800		0,089		
120	0,593	900		0,079		
140	0,508	1 000		0,076		

7.1.4 Mutual coupling and mismatch loss correction factors

Correction factors are included where relevant, to allow for mutual coupling and mismatch loss for the 30 MHz to 180 MHz band, based on using the recommended ANSI C63.5 [1] dipoles. These have been calculated by computer modelling of their baluns, sectional arms and the testing arrangements (i.e. range length and optimized height above the ground plane). The factors are only valid for this particular type of dipole. However, if this type is unavailable, an alternative could be used. This alternative should be a tuned half wavelength dipole at the particular test frequency. Since correction factors have not been calculated for any type other than the ANSI C63.5 [1] dipoles this will result in a greater expanded uncertainty for the measurement unless the test house/manufacturer has performed equivalent modelling on the dipoles used.

7.1.5 Power supplies to the EUT

All tests should be performed using power supplies wherever possible, including tests on EUTs designed for battery-only use. In all cases, power leads should be connected to the EUTs supply terminals (and monitored with a digital voltmeter) but the battery should remain present, electrically isolated from the rest of the EUT, possibly by putting tape over its contacts. All leads involved should be taken down to the floor of the facility by the shortest possible routes, twisting pairs together and loading with ferrite beads at 0,15 m spacing.

7.1.6 Restrictions

For both types of anechoic facility, no part of any antenna or EUT should come within 1 m of any part of the absorbing panels at any time during testing.

Similarly, for both types of ground reflection range, no part of any antenna should come within 0,25 m of the ground plane.

7.2 Transmitter tests

7.2.1 Frequency error

This test is not usually performed on a Salty man/Salty-lite and is therefore not considered here.

7.2.2 Effective radiated power

This test is not usually performed on a Salty man/Salty-lite and is therefore not considered here.

7.2.3 Spurious emissions

This test is not usually performed on a Salty man/Salty-lite and is therefore not considered here.

7.2.4 Adjacent channel power

This test is not usually performed on a Salty man/Salty-lite and is therefore not considered here.

7.3 Receiver tests

The tests carried out on receivers can be divided into two categories, namely sensitivity and immunity. However, only sensitivity tests are considered here.

The test methods for measuring the maximum or average usable sensitivity of a receiver is in two parts. In the first part, a transform factor for the test site (i.e. the relationship in decibels between the output power level (in dBm) from the signal generator to the resulting electric field strength (in dB μ V/m) at the point of test) is determined. In the second part, the sensitivity of the EUT is measured by finding the lowest output level from the signal generator which produces the required response at each of eight angles in the horizontal plane.

The receiver output depends on the type of information the receiver has been designed to demodulate. There are principally three different types of information: analogue speech, bit stream and messages.

Definition

For analogue speech:

- The **maximum usable sensitivity** expressed as field strength is the minimum of eight field strength (in dB μ V/m) measurements (at 45° increments in the horizontal plane) at the nominal frequency of the receiver and with specified test modulation, which produces a SINAD ratio of 20 dB measured at the receiver input through a telephone psophometric weighting network. The starting horizontal angle is the reference orientation as stated by the manufacturer.

- The **average usable sensitivity** expressed as field strength is the average of eight field strength (in dB μ V/m) measurements (at 45° increments in the horizontal plane) at the nominal frequency of the receiver and with specified test modulation, which produces a SINAD ratio of 20 dB measured at the receiver input through a telephone psophometric weighting network. The starting horizontal angle is the reference orientation as stated by the manufacturer.

For bit stream:

- The **maximum usable sensitivity** expressed as field strength is the minimum of eight field strength (in dB μ V/m) measurements (at 45° increments in the horizontal plane) at the nominal frequency of the receiver and with specified test modulation, which produces, after demodulation, a data signal with a bit error ratio of 10^{-2} measured at the receiver input. The starting horizontal angle is the reference orientation as stated by the manufacturer.
- The **average usable sensitivity** expressed as field strength is the average of eight field strength (in dB μ V/m) measurements (at 45° increments in the horizontal plane) at the nominal frequency of the receiver and with specified test modulation, which produces, after demodulation, a data signal with a bit error ratio of 10^{-2} measured at the receiver input. The starting horizontal angle is the reference orientation as stated by the manufacturer.

For messages:

- The **maximum usable sensitivity** expressed as field strength is the minimum of eight field strength (in dB μ V/m) measurements (at 45° increments in the horizontal plane) at the nominal frequency of the receiver, and with specified test modulation, which produces, after demodulation, a message acceptance ratio of 80 % measured at the receiver input. The starting horizontal angle is the reference orientation as stated by the manufacturer.
- The **average usable sensitivity** expressed as field strength is the average of eight field strength (in dB μ V/m) measurements (at 45° increments in the horizontal plane) at the nominal frequency of the receiver and with specified test modulation, which produces, after demodulation, a message acceptance ratio of 80 % measured at the receiver input. The starting horizontal angle is the reference orientation as stated by the manufacturer.

7.3.1 Sensitivity tests in an anechoic chamber (30 to 1 000 MHz)

7.3.1.1 Apparatus required

- Digital voltmeter.
- Ferrite beads.
- 10 dB attenuators.
- Power supply.
- Connecting cables.
- Anechoic chamber.
- Salty man or Salty-lite.
- Test antenna (half wavelength dipole as detailed in ANSI C63.5 [1] recommended).
- Measuring antenna (half wavelength dipole as detailed in ANSI C63.5 [1] recommended).
- RF Signal generator.
- Receiving device (measuring receiver or spectrum analyser).

Additional requirements for analogue speech:

- AF source.
- SINAD meter (incorporating telephone psophometric weighting network).
- Acoustic coupler (alternatively: audio load).

Additional requirements for bit stream:

- Bit stream generator.
- Bit error measuring test set.

Additional requirements for messages:

- acoustic coupler.
- message generator.
- Response measuring test set.

The types and serial numbers of all items of test equipment should be recorded on page 1 of the log book results sheet (see table 6).

NOTE: The half wavelength dipole antennas, incorporating matching/transforming baluns, for the procedure are available in the following bands: 20 MHz to 65 MHz, 65 MHz to 180 MHz, 180 MHz to 400 MHz, 400 MHz to 1 000 MHz. Constructional details are contained in ANSI C63.5 [1]. In the recommended antenna scheme for this band, a shortened dipole is used at all frequencies from 30 MHz to 80 MHz inclusive.

7.3.1.2 Method of measurement

- 1) The EUT should be mounted on the Salty man/Salty-lite at the height stated in the relevant standard. It should be mounted in an orientation which matches that of its normal usage as declared by the manufacturer.

Determination of the transform factor for the test site

- 2) For this part of the test, it is necessary to position the measuring antenna within the chamber such that its phase centre is at the same point that the phase centre of the EUT (mounted on the Salty man/Salty-lite) will occupy in the second part of the test. The precise point should always be, where possible, on the axis of rotation of the turntable but at a height either on the central axis of the chamber or at a convenient height within the quiet zone. The vertical offset of the phase centre from the central axis (if any) should be either measured remotely or determined by sitting the complete assembly of Salty man/Salty-lite plus EUT on the turntable. The vertical offset from the central axis should be recorded on page 2 of the log book results sheet (table 6).

NOTE 1: If the position of the phase centre within the EUT is unknown, but its antenna is a single rod which is visible and vertical in normal usage, the axis of its antenna should be aligned with the axis of rotation of the turntable. The base of the antenna should be used for determining the height. If the phase centre is not known and there is no visible antenna, the volume centre of the EUT should be aligned with the axis of rotation of the turntable instead.

NOTE 2: The bulk of the Salty man/Salty-lite may offer little flexibility in positioning within the chamber and some offset of the phase centre of the EUT from the axis of rotation might be unavoidable (see figure 7). Where an offset is unavoidable, its value should be entered on page 2 of the log book results sheet (table 6). If the overall positioning of the phase centre cannot be achieved without the dipole either falling outside the quiet zone of the chamber or approaching closer than 1 m to the absorbing panels at any angle of rotation, the test should not be carried out.

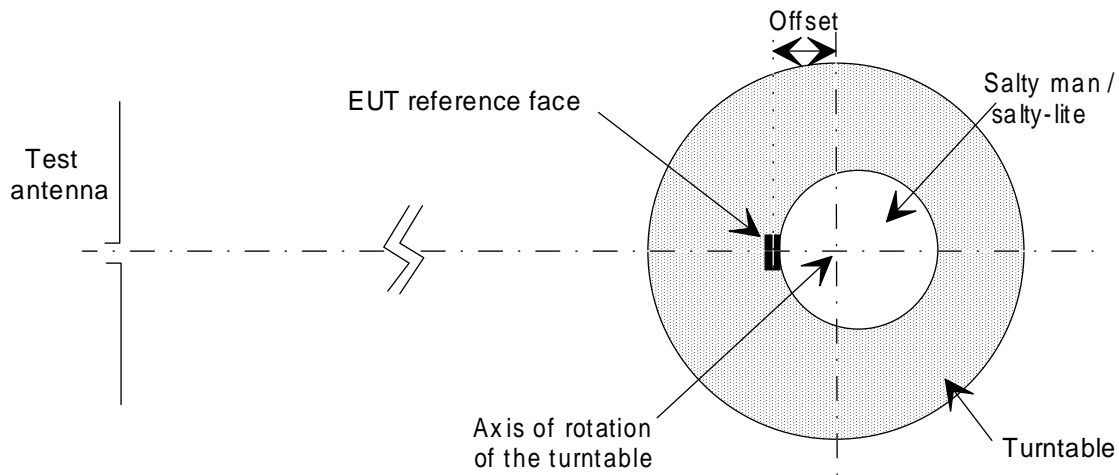

Figure 7: Illustration of offset from the axis of rotation

- 3) The measuring antenna (in the recommended scheme: a tuned ANSI C63.5 [1] half wavelength dipole for frequencies of 80 MHz and above, a shortened dipole for frequencies from 30 MHz to 80 MHz) should be adjusted to correspond to the nominal frequency of the EUT and positioned with its phase centre at the point identified in Step 2. It should be oriented for vertical polarization.

NOTE 3: For all frequencies below 80 MHz, a shortened dipole (as defined in subclause 7.1.3) should be used. The dipole arm length is defined from the centre of the balun block to the tip of the arm. From a fully extended state, each telescopic element, in turn, should be "pushed in" from the tip until the required length is obtained. The outermost section needs to fully compress before any of the others, and so on. Table 4 gives the dipole arm lengths and choice of balun for set frequencies. Where the test frequency does not correspond to a set frequency in the table, the arm length to be used should be determined by linear interpolation between the closest set values.

- 4) The measuring antenna should be connected via a 10 dB attenuator and the calibrated, ferrited coaxial cable associated with that end of the chamber, to the receiving device.
- 5) The test antenna (identical to the measuring antenna) should be tuned to the nominal frequency of the EUT and mounted with the height of its phase centre at the same vertical offset from the central axis of the chamber (if any) as the measuring antenna, so that the measurement axis is parallel to the central axis of the chamber. The test antenna should be oriented to the same polarization as the measuring antenna.

NOTE 4: The measurement axis is the straight line joining the phase centres of the transmitting and receiving devices.

- 6) The test antenna should be connected via a 10 dB attenuator and the calibrated, ferrited coaxial cable associated with that end of the chamber to the signal generator whose output should be unmodulated, (see figure 8). The signal generator should be tuned to the nominal frequency of the EUT.

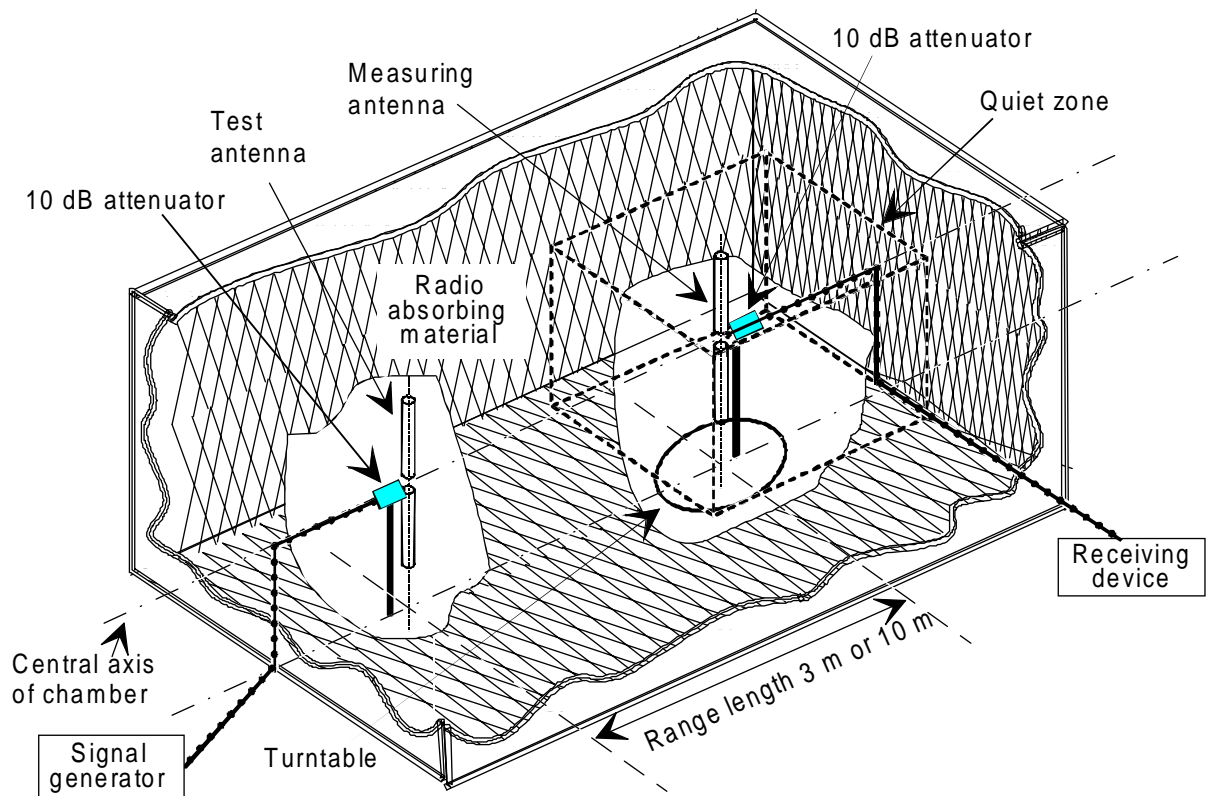

Figure 8: Equipment layout for the derivation of the transform factor during Sensitivity tests in an anechoic chamber

- 7) The output level of the signal generator should be adjusted until a received signal level at least 20 dB above the noise floor is observed on the receiving device.
- 8) The received signal level ($\text{dB}\mu\text{V}$) appearing on the receiving device along with the output level from the signal generator (dBm) should be recorded on page 2 of the log book results sheet (table 6). The transform factor for the chamber (i.e. the factor relating the output power level from the signal generator (dBm) to the resulting field strength ($\text{dB}\mu\text{V}/\text{m}$) at the point of measurement) should then be calculated according to the following formula:

$$\begin{aligned}
 \text{transform factor (dB)} &= \text{received signal level (dB}\mu\text{V)} \\
 &+ \text{measuring antenna cable loss} \\
 &+ \text{measuring antenna attenuator loss} \\
 &+ \text{measuring antenna balun loss} \\
 &+ \text{mutual coupling and mismatch loss correction factor (if applicable)} \\
 &+ \text{antenna factor of the measuring antenna} \\
 &- \text{signal generator output level (dBm)}
 \end{aligned}$$

NOTE 5: Guidance for deriving/calculating/finding the unknown values in the above formula for transform factor are given in table 5. These values should be entered on page 2 of the log book results sheet (table 6).

The resulting value for the transform factor should be entered on page 2 of the log book results sheet (table 6).

Table 5: Guidance for deriving transform factor

Values in the formula for transform factor	
Measuring antenna cable loss	Obtained directly from the calibration data
Measuring antenna attenuator loss	Obtained from calibration data
Measuring antenna balun loss	If not known from calibration data, the value should be taken as 0,30 dB
Mutual coupling and mismatch loss correction factor between the test antenna and the measuring antenna	For ANSI dipoles (30 to 180 MHz) values can be obtained from ETR 273-1-2 [7]. For frequencies > 180 MHz, this value is 0,00 dB. For non-ANSI dipoles this value is 0,00 dB
Antenna factor of the measuring antenna	For ANSI dipoles: Antenna factor = $20 \log_{10}(f) - 31,4$ dB dB/m (where f is the frequency in MHz) For other types the value can be obtained from calibration data

Sensitivity measurement on the EUT

- 9) The measuring antenna should be replaced on the turntable by the complete assembly of Salty man/Salty-lite plus EUT. The EUT should be positioned on the turntable such that its phase centre is in the same place as formerly occupied by the phase centre of the measuring antenna.
- 10) The normal to the reference face of the EUT should point directly towards the test antenna. This is the 0° reference angle for this test. This orientation and mounting configuration should be recorded on page 1 of the log book results sheet (see table 6).

For analogue speech:

- 11a) The EUT should be connected to the modulation detector (a SINAD meter incorporating a telephone psophometric weighting network) through an AF load or by an acoustic coupler which is made from low relative dielectric constant (i.e. less than 1,5) material(s) for EUTs not fitted with a direct connection, (see figure 9).
- 11b) The signal generator output should be modulated with test modulation A-M1 (produced by the AF source) and its output level should be adjusted until a psophometrically weighted SINAD ratio of 20 dB is obtained from the EUT. The corresponding signal generator output power level (dBm) should be recorded on page 2 of the log book results sheet (table 6).
- 11c) The Salty man/Salty-lite and EUT complete assembly should be successively rotated through 45° in the horizontal plane to new testing angles of 45°, 90°, 135°, 180°, 225°, 270°, 315° (thereby covering the entire 360° in eight measurements). At each angle, Step 11b should be repeated.
- 11d) The eight values of signal generator output power level resulting from Steps 11b and 11c should be converted into field strength values by firstly adding the transform factor to produce the field strength in dBμV/m and then secondly converting dBμV/m to μV/m i.e.:
 - 1) field strength (dBμV/m) = signal generator level (dBm) + transform factor (dB);
 - 2) field strength (μV/m) = $10^{(\text{field strength}(\text{dB}\mu\text{V}/\text{m})/20)}$.

The resulting values in μV/m should be recorded on page 2 of the log book results sheet (table 6).

- 11e) The procedure should now resume with Step 12.

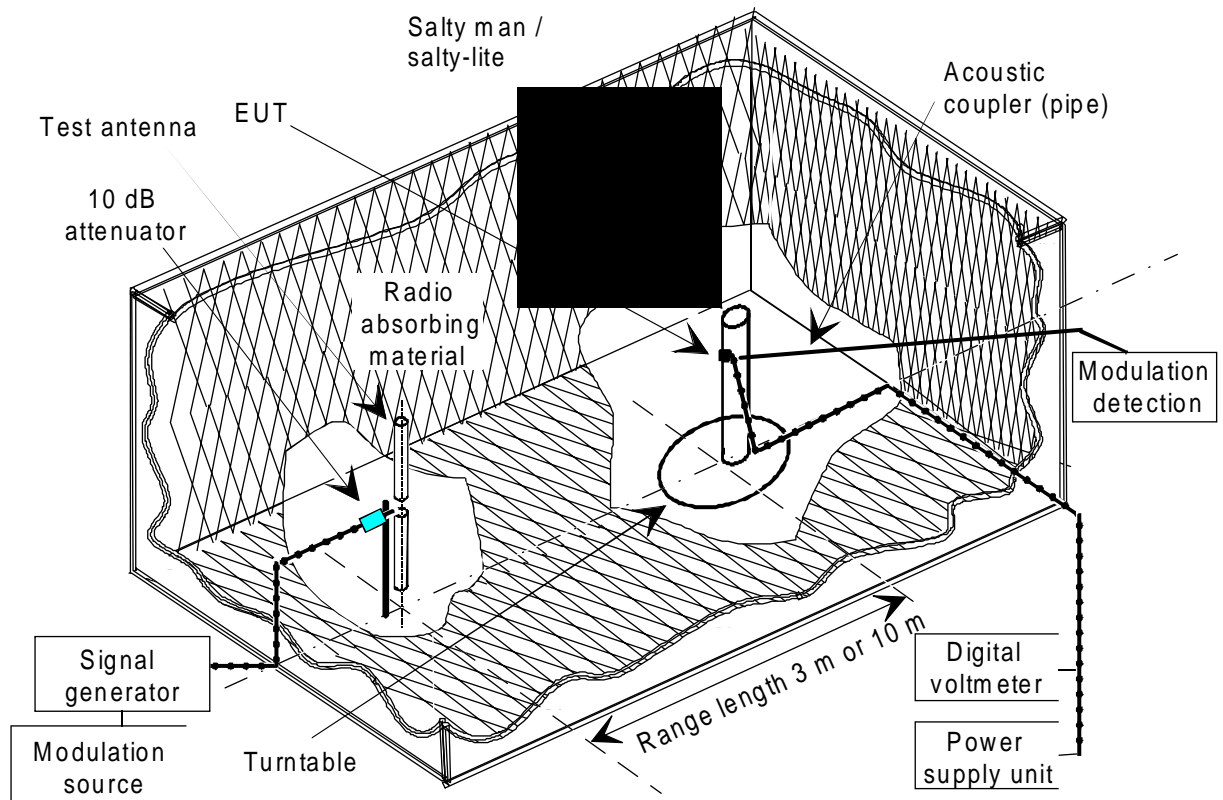

Figure 9: Anechoic chamber set-up for Sensitivity tests on the EUT

For bit stream:

- 11a) The EUT should be connected to the modulation detector (a bit error) measuring test set, which should also receive a direct input from the bit stream generator) by a direct connection, (see figure 9).
- 11b) The signal generator output should be modulated by the test modulation D-M2 (produced by the bit stream generator) and its output level should be adjusted until a bit error ratio of 10^{-2} is obtained from the EUT. The corresponding signal generator output power level (dBm) should be recorded on page 2 of the log book results sheet (table 6).
- 11c) The Salty man/Salty-lite and EUT complete assembly should be successively rotated through 45° in the horizontal plane to new testing angles of 45° , 90° , 135° , 180° , 225° , 270° , 315° (thereby covering the entire 360° in eight measurements). At each angle, Step 11b should be repeated.
- 11d) The eight values of signal generator output power level resulting from Steps 11b and 11c should be converted into field strength values by firstly adding the transform factor to produce the field strength in $\text{dB}\mu\text{V}/\text{m}$ and then secondly converting $\text{dB}\mu\text{V}/\text{m}$ to $\mu\text{V}/\text{m}$ i.e.:
 - 1) field strength ($\text{dB}\mu\text{V}/\text{m}$) = signal generator level (dBm) + transform factor (dB);
 - 2) field strength ($\mu\text{V}/\text{m}$) = $10^{(\text{field strength}(\text{dB}\mu\text{V}/\text{m})/20)}$.

The resulting values in $\mu\text{V}/\text{m}$ should be recorded on page 2 of the log book results sheet (see table 6).

- 11e) The procedure should now resume with Step 12.

For messages:

- 11a) The EUT should be connected to the modulation detector (a response measuring test set) via an acoustic coupler (pipe) which is made from low relative dielectric constant (i.e. less than 1,5) material(s) (see figure 9).

- 11b) The signal generator output should be modulated with test modulation DM-3 (produced by the message generator) and its output level should be adjusted until a message acceptance ratio of less than 10 % is obtained from the EUT.
- 11c) The test message should be transmitted repeatedly from the test antenna, whilst observing for each message whether a successful response is obtained. The output level of the signal generator should be increased by 2 dB for each occasion that a successful response is **not** obtained.
- 11d) Step 11c should be repeated until three consecutive successful responses are observed at the same output level from the signal generator. The output level from the signal generator should be recorded on page 2 of the log book results sheet (table 6).
- 11e) The output signal level from the signal generator should be reduced by 1 dB. The new signal level should be recorded on page 2 of the log book results sheet (table 6) and the response of the EUT observed.
- 11f) If a successful response is NOT obtained, the output signal level should be increased by 1 dB and the new level recorded in the results sheet. If a successful response **is** obtained, the input level should not be changed until three consecutive successful responses have been observed. In this case, the output signal level from the signal generator should be reduced by 1 dB and the new level recorded in the results sheet. No signal levels should be recorded unless preceded by a change of level.
- 11g) Step 11f should be repeated until a total of 10 recorded values for the signal generator output level have been entered on page 2 of the log book results sheet (table 6).
- 11h) The Salty man/Salty-lite and EUT complete assembly should be successively rotated through 45° in the horizontal plane to new testing angles of 45°, 90°, 135°, 180°, 225°, 270°, 315° (thereby covering the entire 360° in eight measurements). At each angle Steps 11b to 11g should be repeated.
- 11i) For each angle, the 10 recorded values of the signal generator output level (dBm) should be converted to field strength (μV/m) by firstly adding the transform factor to produce the field strength in dBμV/m and then secondly converting dBμV/m to μV/m i.e.:
- 1) field strength (dBμV/m) = signal generator level (dBm) + transform factor (dB);
 - 2) field strength (μV/m) = $10^{(\text{field strength (dB}\mu\text{V/m)}/20)}$.

The resulting values in μV/m should be entered on page 2 of the log book results sheet (table 6).

- 11j) For each angle, the 10 new recorded values of field strength in μV/m should be averaged according to the following formula:

$$\text{average field strength } (\mu\text{V/m}) = \sqrt{\left(\frac{10}{\sum_{i=1}^{10} \frac{1}{\text{field strength } (\mu\text{V/m})_i^2}} \right)}$$

The resulting eight average values should also be entered on page 2 of the log book results sheet (table 6).

- 11k) The procedure should continue with Step 12.
- 12) For the maximum sensitivity test only, the lowest of the eight values of field strength ($\mu\text{V}/\text{m}$) calculated during the multiple-stage Step 11 represents the minimum field strength to which the EUT responds. This lowest value of field strength ($\mu\text{V}/\text{m}$) should be entered on page 2 of the log book results sheet (table 6) as the maximum sensitivity.
- 13) For the average sensitivity test only, the average of the eight values of field strength ($\mu\text{V}/\text{m}$) calculated during the multiple-stage Step 11 represents the average field strength to which the EUT responds. This average value of field strength in $\mu\text{V}/\text{m}$ should now be calculated by the following:

$$\text{average field strength } (\mu\text{V}/\text{m}) = \sqrt{\left(\frac{8}{\sum_{i=1}^8 \text{field strength } (\mu\text{V}/\text{m})_i^2} \right)}$$

This value of average field strength ($\mu\text{V}/\text{m}$) should be entered on page 2 of the log book results sheet (table 6) as the average sensitivity.

- 14) Steps 2 to 13 should be repeated with both the test and measuring antennas oriented for horizontal polarization.

7.3.1.3 Procedure for completing the results sheets

All the necessary processing of the measured results is carried out during the course of the test procedure. The only calculation that remains to be performed before the overall results sheet (table 7) can be completed is the determination of the expanded uncertainty of the measurement. This should be carried out in accordance with subclause 7.3.2 and the resulting value entered in the overall results sheet (table 7).

7.3.1.4 Log book entries

Table 6: Log book results sheet

RECEIVER SENSITIVITY		Date:		PAGE 1 of 2	
Temperature:.....°C		Humidity:.....%		Frequency:.....MHz	
Manufacturer of EUT:.....		Type No:.....		Serial No:.....	
Range length :.....					
Salty : Type:.....		Serial No:.....			
Test equipment item	Type No.	Serial No.	VSWR	Insertion loss	Antenna factor
Test antenna				N/A	
Test antenna attenuator					N/A
Test antenna cable					N/A
Measuring antenna				N/A	
Measuring antenna attenuator					N/A
Measuring antenna cable					N/A
Ferrite beads			N/A	N/A	N/A
Receiving device				N/A	N/A
Signal generator				N/A	N/A
Digital voltmeter			N/A	N/A	N/A
Power supply			N/A	N/A	N/A
AF source (if applicable)			N/A	N/A	N/A
SINAD meter (if applicable)			N/A	N/A	N/A
AF load (if applicable)			N/A	N/A	N/A
Bit stream generator (if applicable)			N/A	N/A	N/A
Bit error measuring test set (if applicable)			N/A	N/A	N/A
Acoustic coupler (if applicable)			N/A	N/A	N/A
Message generator (if applicable)			N/A	N/A	N/A
Response measuring test set (if applicable)			N/A	N/A	N/A
Mounting configuration of EUT					

(continued)

Table 6 (continued): Log book results sheet

RECEIVER SENSITIVITY (analogue speech)									Date:									PAGE 2 of 2		
Vertical Polarization									Horizontal Polarization											
Vertical offset from the central axis			m			Vertical offset from the central axis			m											
Offset from axis of rotation			m			Offset from axis of rotation			m											
Received signal level			dB μ V			Received signal level			dB μ V											
Output level from signal generator			dBm			Output level from signal generator			dBm											
Transform factor			dB			Transform factor			dB											
Signal generator level (dBm) against angle for 20 dB SINAD									Signal generator level (dBm) against angle for 20 dB SINAD											
	0°	45°	90°	135°	180°	225°	270°	325°		0°	45°	90°	135°	180°	225°	270°	325°			
level									level											
Conversion to μ V/m									Conversion to μ V/m											
	0°	45°	90°	135°	180°	225°	270°	325°		0°	45°	90°	135°	180°	225°	270°	325°			
level									level											
MAXIMUM Sensitivity			μ V/m			MAXIMUM Sensitivity			μ V/m											
AVERAGE Sensitivity			μ V/m			AVERAGE Sensitivity			μ V/m											
Values in the formula for transform factor																				
Measuring antenna cable loss						Measuring antenna cable loss														
Measuring antenna attenuator loss						Measuring antenna attenuator loss														
Measuring antenna balun loss						Measuring antenna balun loss														
Mutual coupling and mismatch loss (30 - 180 MHz)						Mutual coupling and mismatch loss (30 - 180 MHz)														
Antenna factor of the measuring antenna						Antenna factor of the measuring antenna														

RECEIVER SENSITIVITY (bit stream)									Date:									PAGE 2 of 2		
Vertical Polarization									Horizontal Polarization											
Vertical offset from the central axis			m			Vertical offset from the central axis			m											
Offset from axis of rotation			m			Offset from axis of rotation			m											
Received signal level			dB μ V			Received signal level			dB μ V											
Output level from signal generator			dBm			Output level from signal generator			dBm											
Transform factor			dB			Transform factor			dB											
Signal generator level (dBm) against angle for 10 ⁻² BER									Signal generator level (dBm) against angle for 10 ⁻² BER											
	0°	45°	90°	135°	180°	225°	270°	325°		0°	45°	90°	135°	180°	225°	270°	325°			
level									level											
Conversion to μ V/m									Conversion to μ V/m											
	0°	45°	90°	135°	180°	225°	270°	325°		0°	45°	90°	135°	180°	225°	270°	325°			
level									level											
MAXIMUM Sensitivity			μ V/m			MAXIMUM Sensitivity			μ V/m											
AVERAGE Sensitivity			μ V/m			AVERAGE Sensitivity			μ V/m											
Values in the formula for transform factor																				
Measuring antenna cable loss						Measuring antenna cable loss														
Measuring antenna attenuator loss						Measuring antenna attenuator loss														
Measuring antenna balun loss						Measuring antenna balun loss														
Mutual coupling and mismatch loss (30 - 180 MHz)						Mutual coupling and mismatch loss (30 - 180 MHz)														
Antenna factor of the measuring antenna						Antenna factor of the measuring antenna														

(continued)

Table 6 (concluded): Log book results sheet

RECEIVER SENSITIVITY (messages)									Date:									PAGE 2 of 2								
Vertical Polarization									Horizontal Polarization																	
Vertical offset from the central axis				m					Vertical offset from the central axis				m													
Offset from axis of rotation				m					Offset from axis of rotation				m													
Received signal level				dBμV					Received signal level				dBμV													
Output level from signal generator				dBm					Output level from signal generator				dBm													
Transform factor				dB					Transform factor				dB													
Signal generator level (dBm) against angle									Signal generator level (dBm) against angle																	
level	0°	45°	90°	135°	180°	225°	270°	325°	level	0°	45°	90°	135°	180°	225°	270°	325°									
1									1																	
2									2																	
3									3																	
4									4																	
5									5																	
6									6																	
7									7																	
8									8																	
9									9																	
10									10																	
Conversion to μV/m									Conversion to μV/m																	
level	0°	45°	90°	135°	180°	225°	270°	325°	level	0°	45°	90°	135°	180°	225°	270°	325°									
1									1																	
2									2																	
3									3																	
4									4																	
5									5																	
6									6																	
7									7																	
8									8																	
9									9																	
10									10																	
Ave.									Ave.																	
MAXIMUM Sensitivity				μV/m					MAXIMUM Sensitivity				μV/m													
AVERAGE Sensitivity				μV/m					AVERAGE Sensitivity				μV/m													
Values in the formula for transform factor																										
Measuring antenna cable loss									Measuring antenna cable loss																	
Measuring antenna attenuator loss									Measuring antenna attenuator loss																	
Measuring antenna balun loss									Measuring antenna balun loss																	
Mutual coupling and mismatch loss (30 - 180 MHz)									Mutual coupling and mismatch loss (30 - 180 MHz)																	
Antenna factor of the measuring antenna									Antenna factor of the measuring antenna																	

7.3.1.5 Statement of results

The results should be presented in tabular form as shown in table 7.

Table 7: Overall results sheet

RECEIVER SENSITIVITY				Date:				PAGE 1 of 1			
Vertical Polarization				Horizontal Polarization							
MAXIMUM Usable Sensitivity		μV/m		MAXIMUM Usable Sensitivity		μV/m					
AVERAGE Usable Sensitivity		μV/m		AVERAGE Usable Sensitivity		μV/m					
Expanded uncertainty (95 %)		dB		Expanded uncertainty (95 %)		dB					

7.3.2 Measurement uncertainty for Receiver Sensitivity (anechoic chamber)

A fully worked example illustrating the methodology to be used can be found in clause 4 of ETR 273-1-2 [7].

7.3.2.1 Uncertainty contributions: Stage 1: Determination of transform factor

The first stage (determining the transform factor) involves placing a measuring antenna as shown in figure 10 and determining the relationship between the signal generator output power level and the resulting field strength (the shaded areas in figure 10 represent components common to both stages of the test).

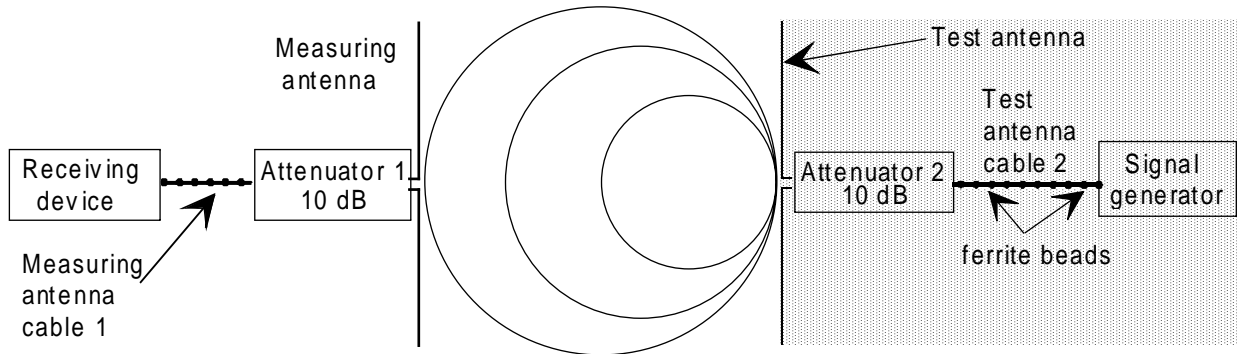

Figure 10: Stage 1: Transform factor

All the uncertainty components which contribute to this stage of the test are listed in table 8. ETR 273-1-2 [7] should be consulted for the sources and/or magnitudes of the uncertainty contributions.

Table 8: Contributions for the transform factor

uj or i	Description of uncertainty contributions	dB
u_{j36}	<i>mismatch: transmitting part</i>	0,00
u_{j37}	<i>mismatch: receiving part</i>	
u_{j38}	<i>signal generator: absolute output level</i>	
u_{j39}	<i>signal generator: output level stability</i>	
u_{j19}	<i>cable factor: measuring antenna cable</i>	
u_{j19}	<i>cable factor: test antenna cable</i>	0,00
u_{j41}	<i>insertion loss: measuring antenna cable</i>	
u_{j41}	<i>insertion loss: test antenna cable</i>	0,00
u_{j40}	<i>insertion loss: measuring antenna attenuator</i>	
u_{j40}	<i>insertion loss: test antenna attenuator</i>	0,00
u_{j47}	<i>receiving device: absolute level</i>	
u_{j16}	<i>range length</i>	0,00
u_{j02}	<i>reflectivity of absorber material: measuring antenna to the test antenna</i>	0,00
u_{j44}	<i>antenna: antenna factor of the measuring antenna</i>	
u_{j45}	<i>antenna: gain of the test antenna</i>	0,00
u_{j46}	<i>antenna: tuning of the measuring antenna</i>	
u_{j46}	<i>antenna: tuning of the test antenna</i>	0,00
u_{j22}	<i>position of the phase centre: measuring antenna</i>	
u_{j06}	<i>mutual coupling: measuring antenna to its images in the absorbing material</i>	
u_{j06}	<i>mutual coupling: test antenna to its images in the absorbing material</i>	0,00
u_{j11}	<i>mutual coupling: measuring antenna to the test antenna</i>	0,00
u_{j12}	<i>mutual coupling: interpolation of mutual coupling and mismatch loss correction factors</i>	0,00
u_{i01}	<i>random uncertainty</i>	

The standard uncertainties from table 8 should be combined by RSS in accordance with clause 5 of ETR 273-1-1 [6]. This gives the combined standard uncertainty (u_c contributions from the Transform Factor) for the transform factor in dB.

7.3.2.2 Uncertainty contributions: Stage 2: EUT measurement

The second stage (the EUT measurement) is to determine the minimum signal generator output level which produces the required response from the EUT as shown in figure 11 (the shaded areas represent components common to both stages of the test).

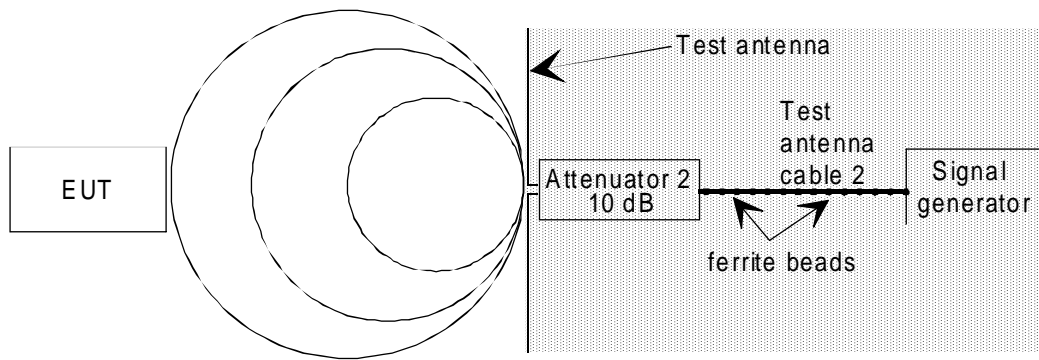

Figure 11: Stage 2: EUT measurement

All the uncertainty components which contribute to this stage of the test are listed in table 9. ETR 273-1-2 [7] should be consulted for the sources and/or magnitudes of the uncertainty contributions.

Table 9: Contributions from the EUT measurement

u _j or i	Description of uncertainty contributions	dB
<i>u_{j36}</i>	<i>mismatch: transmitting part</i>	0,00
<i>u_{j37}</i>	<i>mismatch: receiving part</i>	
<i>u_{j38}</i>	<i>signal generator: absolute output level</i>	
<i>u_{j39}</i>	<i>signal generator: output level stability</i>	
<i>u_{j19}</i>	<i>cable factor: measuring antenna cable</i>	
<i>u_{j19}</i>	<i>cable factor: test antenna cable</i>	0,00
<i>u_{j41}</i>	<i>insertion loss: measuring antenna cable</i>	
<i>u_{j41}</i>	<i>insertion loss: test antenna cable</i>	0,00
<i>u_{j40}</i>	<i>insertion loss: measuring antenna attenuator</i>	
<i>u_{j40}</i>	<i>insertion loss: test antenna attenuator</i>	0,00
<i>u_{j47}</i>	<i>receiving device: absolute level</i>	
<i>u_{j16}</i>	<i>range length</i>	0,00
<i>u_{j02}</i>	<i>reflectivity of absorber material: measuring antenna to the test antenna</i>	0,00
<i>u_{j44}</i>	<i>antenna: antenna factor of the measuring antenna</i>	
<i>u_{j45}</i>	<i>antenna: gain of the test antenna</i>	0,00
<i>u_{j46}</i>	<i>antenna: tuning of the measuring antenna</i>	
<i>u_{j46}</i>	<i>antenna: tuning of the test antenna</i>	0,00
<i>u_{j22}</i>	<i>position of the phase centre: measuring antenna</i>	
<i>u_{j06}</i>	<i>mutual coupling: measuring antenna to its images in the absorbing material</i>	
<i>u_{j06}</i>	<i>mutual coupling: test antenna to its images in the absorbing material</i>	0,00
<i>u_{j11}</i>	<i>mutual coupling: measuring antenna to the test antenna</i>	0,00
<i>u_{j12}</i>	<i>mutual coupling: interpolation of mutual coupling and mismatch loss correction factors</i>	0,00
<i>u_{j58}</i>	<i>Salty man/salty-lite: human simulation</i>	
<i>u_{j59}</i>	<i>Salty man/salty-lite: field enhancement and de-tuning of the EUT</i>	
<i>u_{i01}</i>	<i>random uncertainty</i>	

The standard uncertainties from table 9 should be combined by RSS in accordance with clause 5 of ETR 273-1-1 [6]. This gives the combined standard uncertainty (u_c contribution from the EUT measurement) for the EUT measurement in dB.

7.3.2.3 Expanded uncertainty of the receiver sensitivity measurement

The combined uncertainty of the sensitivity measurement is the combination of the components outlined in subclauses 7.3.2.1 and 7.3.2.2. The components to be combined are u_c contribution from the Transform Factor and u_c contribution from the EUT measurement

$$u_c = \sqrt{u_{c \text{ contribution from the Transform Factor}}^2 + u_{c \text{ contribution from the EUT measurement}}^2} = _,_ \text{ dB}$$

The expanded uncertainty is $\pm 1,96 * u_c = \pm _,_ \text{ dB}$ at a 95 % confidence level.

7.3.3 Sensitivity tests in an anechoic chamber with ground plane (30 MHz to 1 000 MHz)

7.3.3.1 Apparatus required

- digital voltmeter;
- ferrite beads;
- 10 dB attenuators;
- power supply;
- connecting cables;
- anechoic chamber with a ground plane;
- Salty man or Salty-lite;
- test antenna (half wavelength dipole as detailed in ANSI C63.5 [1] recommended);
- measuring antenna (half wavelength dipole as detailed in ANSI C63.5 [1] recommended);
- RF Signal generator;
- receiving device (measuring receiver or spectrum analyser).

Additional requirements for analogue speech:

- AF source;
- SINAD meter (incorporating telephone psophometric weighting network);
- acoustic coupler (alternatively: audio load).

Additional requirements for bit stream:

- bit stream generator;
- bit error measuring test set.

Additional requirements for messages:

- acoustic coupler;
- message generator;
- response measuring test set.

The types and serial numbers of all items of test equipment should be recorded on page 1 of the log book results sheet (table 11).

NOTE: The half wavelength dipole antennas, incorporating matching/transforming baluns, for the procedure are available in the following bands: 20 MHz to 65 MHz, 65 MHz to 180 MHz, 180 MHz to 400 MHz, 400 MHz to 1 000 MHz. Constructional details are contained in ANSI C63.5 [1]. In the recommended antenna scheme for this band, a shortened dipole is used at all frequencies from 30 MHz to 80 MHz.

7.3.3.2 Method of measurement

- 1) The EUT should be mounted on the Salty man/Salty-lite at the height stated in the relevant Standard. It should be mounted in an orientation which matches that of its normal usage as declared by the manufacturer.

Determination of the transform factor for the test site

- 2) For this part of the test, it is necessary to position the measuring antenna such that its phase centre is at the same point that the phase centre of the EUT (mounted on the Salty man/Salty-lite) will occupy in the second part of the test. The precise point should always be, where possible, on the axis of rotation of the turntable but at a height above its mounting surface that should either be measured remotely or determined by sitting the complete assembly of Salty man/Salty-lite plus EUT on the turntable. The height above the turntable should be recorded on page 2 of the log book results sheet (table 11).

NOTE 1: If the position of the phase centre within the EUT is unknown, but its antenna is a single rod which is visible and vertical in normal usage, the axis of its antenna should be aligned with the axis of rotation of the turntable. The base of the antenna should be used for determining the height. If the phase centre is not known and there is no visible antenna, the volume centre of the EUT should be aligned with the axis of rotation of the turntable instead.

NOTE 2: The bulk of the Salty man/Salty-lite may offer little flexibility in positioning within the chamber and some offset of the phase centre of the EUT from the axis of rotation might be unavoidable (see figure 7). Where an offset is unavoidable, its value should be entered on page 2 of the log book results sheet (table 6). If the overall positioning of the phase centre cannot be achieved without the dipole either falling outside the quiet zone of the chamber or approaching closer than 1 m to the absorbing panels at any angle of rotation, the test should not be carried out.

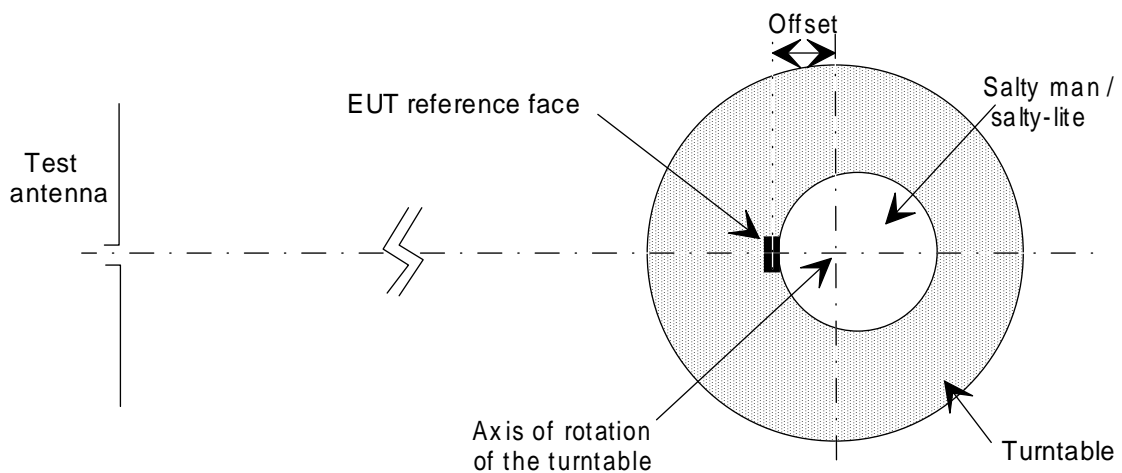

Figure 12: Illustration of offset from the axis of rotation

- 3) The measuring antenna (in the recommended scheme: a tuned ANSI C63.5 [1] half wavelength dipole for frequencies of 80 MHz and above, a shortened dipole for frequencies from 30 MHz to 80 MHz) should be adjusted to correspond to the nominal frequency of the EUT and positioned with its phase centre at the point identified in Step 2. It should be oriented for vertical polarization.

NOTE 3: For all frequencies below 80 MHz, a shortened dipole (as defined in subclause 7.1.3) should be used. The dipole arm length is defined from the centre of the balun block to the tip of the arm. From a fully extended state, each telescopic element, in turn, should be "pushed in" from the tip until the required length is obtained. The outermost section needs to fully compress before any of the others, and so on. Table 4 gives the dipole arm lengths and choice of balun for set frequencies. Where the test frequency does not correspond to a set frequency in the table, the arm length to be used should be determined by linear interpolation between the closest set values.

- 4) The measuring antenna should be connected via a 10 dB attenuator and the calibrated, ferrited coaxial cable associated with that end of the test site, to the receiving device.
- 5) The test antenna (identical to the measuring antenna) should be mounted on the antenna mast, tuned to the nominal frequency of the EUT and oriented for vertical polarization.
- 6) The test antenna should be connected via a 10 dB attenuator and the calibrated, ferrited coaxial cable associated with that end of the test site, to the signal generator whose output is unmodulated, (see figure 13. The signal generator should be tuned to the nominal frequency of the EUT.

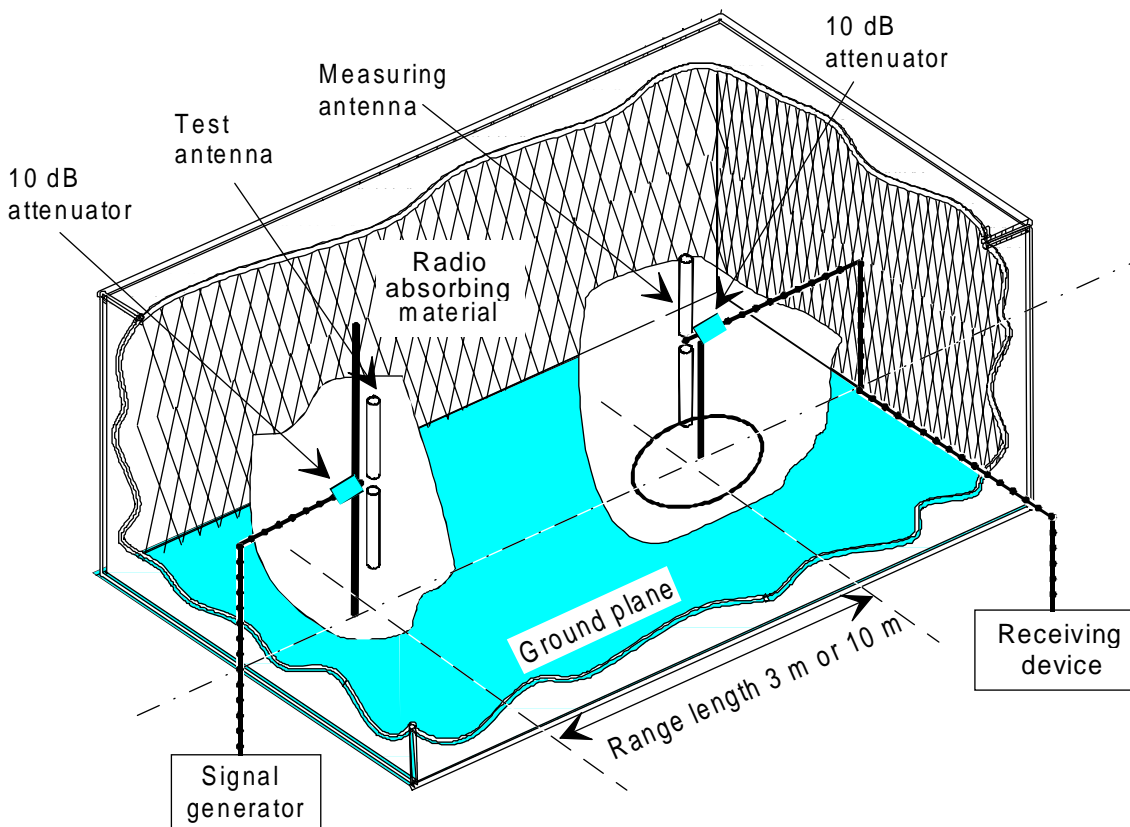

Figure 13: Equipment layout for the derivation of the transform factor during receiver sensitivity tests in an anechoic chamber with a ground plane

- 7) The output level of the signal generator should be adjusted until a received signal level at least 20 dB above the noise floor is observed on the receiving device.
- 8) The test antenna should be raised and lowered through the specified range of heights whilst monitoring the received signal level on the receiving device. The test antenna should be positioned at the height corresponding to the maximum received signal. This height should be recorded on page 2 of the log book results sheet (table 11).

NOTE 4: The true maximum may lie beyond the top of the mast, in which case the maximum receivable level should be at the top of the height range.

- 9) The measuring antenna should be rotated in the horizontal plane until the maximum level is detected on the receiving device.

NOTE 5: This is to correct for possible misalignment of a directional beam i.e. dipoles used in horizontally polarized tests. This step can be omitted when dipoles are used in vertically polarized tests.

- 10) The maximum received signal level (dB μ V) appearing on the receiving device along with the output level from the signal generator (dBm) should be recorded on page 2 of the log book results sheet (table 11). The transform factor for the chamber (i.e. a factor relating the output power level from the signal generator (dBm) to the resulting field strength (dB μ V/m) at the point of measurement) should be calculated according to the following formula:

$$\begin{aligned}
 \text{transform factor (dB)} &= \text{received signal level (dB}\mu\text{V)} \\
 &+ \text{measuring antenna cable loss} \\
 &+ \text{measuring antenna attenuator loss} \\
 &+ \text{measuring antenna balun loss} \\
 &+ \text{mutual coupling and mismatch loss correction factor (if applicable)} \\
 &+ \text{antenna factor of the measuring antenna} \\
 &- \text{signal generator output level (dBm)}
 \end{aligned}$$

NOTE 6: Guidance for deriving/calculating/finding the unknown values in the above formula for transform factor are given in table 10. These values should be entered on page 2 of the log book results sheet (table 11).

The resulting value for the transform factor should be entered on page 2 of the log book results sheet (table 11).

Table 10: Guidance for deriving transform factor

Values in the formula for transform factor	
Measuring antenna cable loss	Obtained directly from the calibration data
Measuring antenna attenuator loss	Obtained from calibration data
Measuring antenna balun loss	If not known from calibration data, the value should be taken as 0,30 dB
Mutual coupling and mismatch loss correction factor between the test antenna and the measuring antenna	For ANSI dipoles (30 to 180 MHz) values can be obtained from ETR 273-1-2 [7]. For frequencies > 180 MHz, this value is 0,00 dB. For non-ANSI dipoles this value is 0,00 dB
Antenna factor of the measuring antenna	For ANSI dipoles: Antenna factor = $20 \log_{10} (f) - 31,4$ dB dB/m (where f is the frequency in MHz) For other types the value can be obtained from calibration data

Sensitivity measurement on the EUT

- 11) The measuring antenna should be replaced on the turntable by the complete assembly of Salty man/Salty-lite plus EUT. The EUT should be positioned such that its phase centre is in the same place as formerly occupied by the phase centre of the measuring antenna.
- 12) The normal to the reference face of the EUT should point directly towards the test antenna. This is the 0° reference angle for this test. This orientation and mounting configuration should be recorded on page 1 of the log book results sheet (table 11).

For analogue speech:

- 13a) The EUT should be connected to the modulation detector (a SINAD meter incorporating a telephone psophometric weighting network) through an AF load or by an acoustic coupler which is made from low dielectric constant (i.e. less than 1,5) material(s) for EUTs not fitted with a direct connection (see figure 14).
- 13b) The signal generator output should be modulated with test modulation AM-1 (produced by the AF source) and its output level should be adjusted until a psophometrically weighted SINAD ratio of 20 dB is obtained from the EUT. The corresponding signal generator output power level should be recorded on page 2 of the log book results sheet (table 11).
- 13c) The Salty man/Salty-lite plus EUT complete assembly should be successively rotated through 45° in the horizontal plane to new testing angles of 45°, 90°, 135°, 180°, 225°, 270°, 315° (thereby covering the entire 360° in 8 measurements). At each angle Step 13b should be repeated.
- 13d) The eight values of signal generator output power level resulting from Steps 13b and 13c should be converted into field strength values by firstly adding the transform factor to produce the field strength in dBµV/m and then secondly converting dBµV/m to µV/m i.e.:
 - 1) field strength (dBµV/m) = signal generator level (dBm) + transform factor (dB);
 - 2) field strength (µV/m) = $10^{(\text{field strength (dBµV/m)}/20)}$.

The resulting values in µV/m should be also entered on page 2 of the log book results sheet (table 11).

- 13e) The procedure should now resume with Step 14.

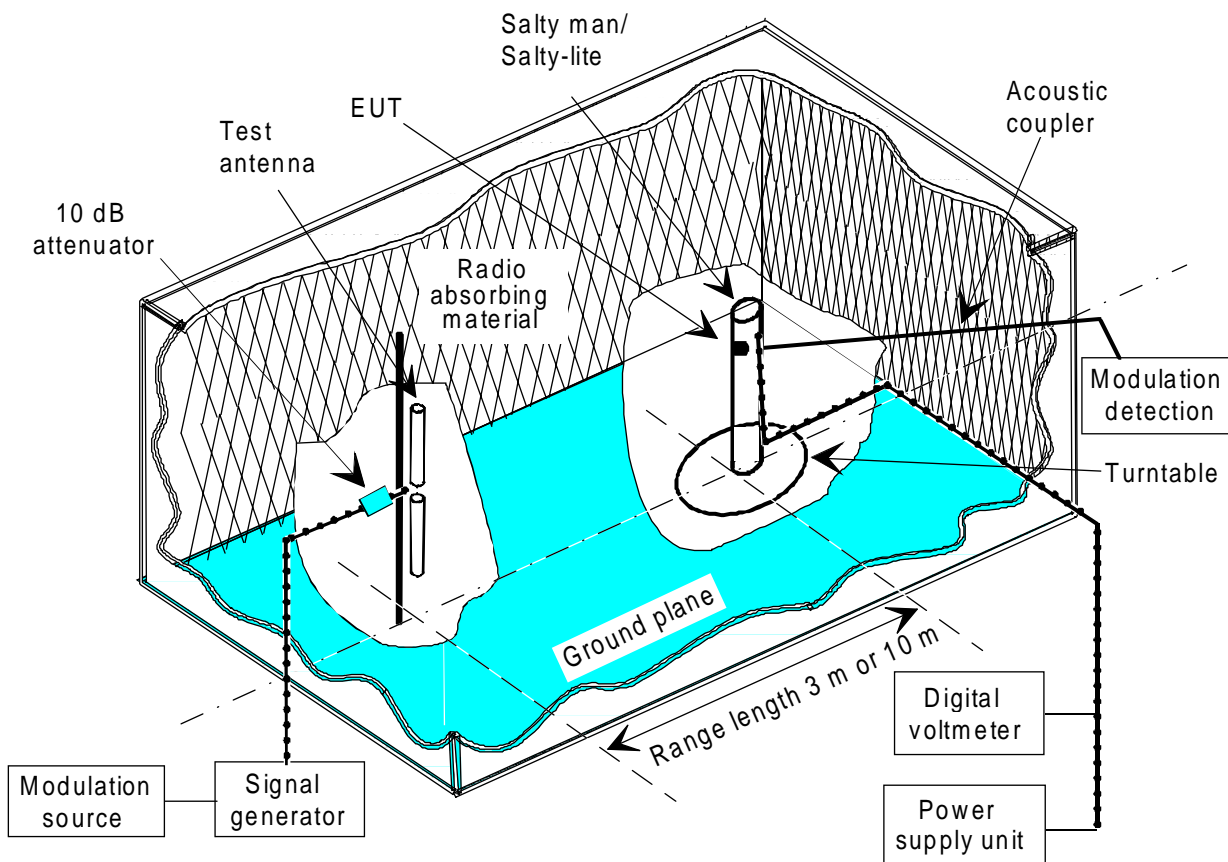

Figure 14: Anechoic chamber with a ground plane set-up for sensitivity tests on the EUT

For bit stream:

- 13a) The EUT should be connected to the modulation detector (a bit error measuring test set, which should also receive a direct input from the bit stream generator) by a direct connection, (see figure 14).
- 13b) The signal generator output should be modulated with test modulation DM-2 (produced by the bit stream generator) and its output level should be adjusted until a bit error ratio of 10^{-2} is obtained from the EUT. The corresponding signal generator output power level (dBm) should be recorded on page 2 of the log book results sheet (table 11).
- 13c) The Salty man/Salty-lite and EUT complete assembly should be successively rotated through 45° in the horizontal plane to new testing angles of 45° , 90° , 135° , 180° , 225° , 270° , 315° (thereby covering the entire 360° in 8 measurements). At each angle Step 13b should be repeated.
- 13d) The eight values of signal generator output power level resulting from Steps 13b and 13c should be converted into field strength values by firstly adding the transform factor to produce the field strength in dB μ V/m and then secondly converting dB μ V/m to μ V/m i.e.:
- 1) field strength (dB μ V/m) = signal generator level (dBm) + transform factor (dB);
 - 2) field strength (μ V/m) = $10^{(\text{field strength (dB}\mu\text{V/m)}/20)}$.
- The resulting values in μ V/m should be also entered on page 2 of the log book results sheet (table 11).
- 13e) The procedure should now resume with Step 14.

For messages:

- 13a) The EUT should be connected to the modulation detector (a response measuring test set) via an acoustic coupler (pipe) which is made from low relative dielectric constant (i.e. less than 1,5) material(s) (see figure 14).
- 13b) The signal generator output should be modulated with test modulation DM-3 (produced by the message generator) and its output level should be adjusted until a message acceptance ratio of less than 10 % is obtained from the EUT.
- 13c) The test message should be transmitted repeatedly from the test antenna, whilst observing for each message whether a successful response is obtained. The output level of the signal generator should be increased by 2 dB for each occasion that a successful response is **not** obtained.
- 13d) Step 13c should be repeated until three consecutive successful responses are observed at the same output level from the signal generator. The output level from the signal generator should be recorded on page 2 of the log book results sheet (table 11).
- 13e) The output signal level from the signal generator should be reduced by 1 dB. The new signal level should be recorded on page 2 of the log book results sheet (table 11) and the response of the EUT observed.
- 13f) If a successful response is **not** obtained, the output signal level should be increased by 1 dB and the new level recorded in the results sheet. If a successful response **is** obtained, the input level should not be changed until three consecutive successful responses have been observed. In this case, the output signal level from the signal generator should be reduced by 1 dB and the new level recorded in the results sheet. No signal levels should be recorded unless preceded by a change of level.
- 13g) Step 13f should be repeated until a total of 10 recorded values for the signal generator output level have been entered on page 2 of the log book results sheet (table 11).

- 13h) The Salty man/Salty-lite and EUT complete assembly should be successively rotated through 45° in the horizontal plane to new testing angles of 45°, 90°, 135°, 180°, 225°, 270°, 315° (thereby covering the entire 360° in eight measurements). At each angle Steps 13b to 13g should be repeated.
- 13i) For each angle, the 10 recorded values of the signal generator output level (dBm) should be converted to field strength (μV/m) by firstly adding the transform factor to produce the field strength in dBμV/m and then secondly converting dBμV/m to μV/m i.e.:
- 1) field strength (dBμV/m) = signal generator level (dBm) + transform factor (dB);
 - 2) field strength (μV/m) = 10^{(field strength(dBμV/m)/20)}.

The resulting values in μV/m should be also entered on page 2 of the log book results sheet (table 11).

- 13j) For each angle, the 10 new recorded values of field strength in μV/m should be averaged according to the following formula:

$$\text{average field strength } (\mu\text{V/m}) = \sqrt{\left(\frac{10}{\sum_{i=1}^{i=10} \frac{1}{\text{field strength } (\mu\text{V/m})_i^2}} \right)}$$

The resulting eight average values should also be entered on page 2 of the log book results sheet (table 11).

- 13k) The procedure should continue with Step 14.
- 14) For the maximum sensitivity test only, the lowest of the eight values of field strength (dBμV/m) calculated during the multiple-stage Step 13 represents the minimum field strength to which the EUT responds. This lowest value of field strength (μV/m) should be entered on page 2 of the log book results sheet (table 11) as the maximum sensitivity.
- 15) For the average sensitivity test only, the average of the eight values of field strength (dBμV/m) calculated during the multiple-stage Step 13 represents the average field strength to which the EUT responds. This average value of field strength in μV/m should now be calculated by the following:

$$\text{Average field strength } (\mu\text{V/m}) = \sqrt{\left(\frac{8}{\sum_{i=1}^{i=8} \frac{1}{\text{field strength } (\mu\text{V/m})_i^2}} \right)}$$

This average value of field strength (μV/m) should be entered on page 2 of the log book results sheet (table 11) as the average sensitivity.

- 16) Steps 2 to 15 should be repeated with both the test and measuring antennas oriented for horizontal polarization.

7.3.3.3 Procedure for completion of the results sheets

All the necessary processing of the measured results is carried out during the course of the test procedure. The only calculation that remains to be performed before the overall results sheet (table 12) can be completed is the determination of the expanded uncertainty of the measurement. This should be performed as given in subclause 7.3.4 and the resulting value entered in the overall results sheet (table 12).

7.3.3.4 Log book entries

Table 11: Log book results sheet

RECEIVER SENSITIVITY		Date:		PAGE 1 of 2	
Temperature:.....°C		Humidity:.....%		Frequency:.....MHz	
Manufacturer of EUT:.....		Type No:.....		Serial No:.....	
Range length :.....					
Salty : Type:.....			Serial No:.....		
Test equipment item	Type No.	Serial No.	VSWR	Insertion loss	Antenna factor
Test antenna				N/A	
Test antenna attenuator					N/A
Test antenna cable					N/A
Measuring antenna				N/A	
Measuring antenna attenuator					N/A
Measuring antenna cable					N/A
Ferrite beads			N/A	N/A	N/A
Receiving device				N/A	N/A
Signal generator				N/A	N/A
Digital voltmeter			N/A	N/A	N/A
Power supply			N/A	N/A	N/A
Audio frequency source (if applicable)			N/A	N/A	N/A
SINAD meter (if applicable)			N/A	N/A	N/A
Audio frequency load (if applicable)			N/A	N/A	N/A
Bit stream generator (if applicable)			N/A	N/A	N/A
Bit error measuring test set (if applicable)			N/A	N/A	N/A
Acoustic coupler (if applicable)			N/A	N/A	N/A
Message generator (if applicable)			N/A	N/A	N/A
Response measuring test set (if applicable)			N/A	N/A	N/A
Mounting configuration of EUT					

(continued)

Table 11 (continued): Log book results sheet

RECEIVER SENSITIVITY (analogue speech)									Date:	PAGE 2 of 2								
Vertical polarization									Horizontal polarization									
Height of the test antenna			m			Height of the test antenna			m									
Offset from the axis of rotation			m			Offset from the axis of rotation			m									
Received signal level			dB μ V			Received signal level			dB μ V									
Output level from signal generator			dBm			Output level from signal generator			dBm									
Transform factor			dB			Transform factor			dB									
Signal generator level (dBm) against angle for 20 dB SINAD									Signal generator level (dBm) against angle for 20 dB SINAD									
	0°	45°	90°	135°	180°	225°	270°	325°		0°	45°	90°	135°	180°	225°	270°	325°	
level									level									
Conversion to μ V/m									Conversion to μ V/m									
	0°	45°	90°	135°	180°	225°	270°	325°		0°	45°	90°	135°	180°	225°	270°	325°	
level									level									
MAXIMUM Sensitivity			μ V/m			MAXIMUM Sensitivity			μ V/m									
AVERAGE Sensitivity			μ V/m			AVERAGE Sensitivity			μ V/m									
Values in the formula for transform factor																		
Measuring antenna cable loss						Measuring antenna cable loss												
Measuring antenna attenuator loss						Measuring antenna attenuator loss												
Measuring antenna balun loss						Measuring antenna balun loss												
Mutual coupling and mismatch loss (30 - 180 MHz)						Mutual coupling and mismatch loss (30 - 180 MHz)												
Antenna factor of the measuring antenna						Antenna factor of the measuring antenna												

RECEIVER SENSITIVITY (bit stream)									Date:	PAGE 2 of 2								
Vertical polarization									Horizontal polarization									
Height of the test antenna			m			Height of the test antenna			m									
Offset from the axis of rotation			m			Offset from the axis of rotation			m									
Received signal level			dB μ V			Received signal level			dB μ V									
Output level from signal generator			dBm			Output level from signal generator			dBm									
Transform factor			dB			Transform factor			dB									
Signal generator level (dBm) against angle for 10 ⁻² BER									Signal generator level (dBm) against angle for 10 ⁻² BER									
	0°	45°	90°	135°	180°	225°	270°	325°		0°	45°	90°	135°	180°	225°	270°	325°	
level									level									
Conversion to μ V/m									Conversion to μ V/m									
	0°	45°	90°	135°	180°	225°	270°	325°		0°	45°	90°	135°	180°	225°	270°	325°	
level									level									
MAXIMUM Sensitivity			μ V/m			MAXIMUM Sensitivity			μ V/m									
AVERAGE Sensitivity			μ V/m			AVERAGE Sensitivity			μ V/m									
Values in the formula for transform factor																		
Measuring antenna cable loss						Measuring antenna cable loss												
Measuring antenna attenuator loss						Measuring antenna attenuator loss												
Measuring antenna balun loss						Measuring antenna balun loss												
Mutual coupling and mismatch loss (30 - 180 MHz)						Mutual coupling and mismatch loss (30 - 180 MHz)												
Antenna factor of the measuring antenna						Antenna factor of the measuring antenna												

(continued)

Table 11 (concluded): Log book results sheet

RECEIVER SENSITIVITY (messages)										Date:		PAGE 2 of 2					
Vertical polarization					Horizontal polarization												
Height of the test antenna					m					Height of the test antenna		m					
Offset from the axis of rotation					m					Offset from the axis of rotation		m					
Received signal level					dB μ V					Received signal level		dB μ V					
Output level from signal generator					dBm					Output level from signal generator		dBm					
Transform factor					dB					Transform factor		dB					
Signal generator level (dBm) against angle					Signal generator level (dBm) against angle												
level	0°	45°	90°	135°	180°	225°	270°	325°	level	0°	45°	90°	135°	180°	225°	270°	325°
1									1								
2									2								
3									3								
4									4								
5									5								
6									6								
7									7								
8									8								
9									9								
10									10								
Conversion to μ V/m					Conversion to μ V/m												
level	0°	45°	90°	135°	180°	225°	270°	325°	level	0°	45°	90°	135°	180°	225°	270°	325°
1									1								
2									2								
3									3								
4									4								
5									5								
6									6								
7									7								
8									8								
9									9								
10									10								
Ave.									Ave.								
MAXIMUM Sensitivity					μ V/m					MAXIMUM Sensitivity		μ V/m					
AVERAGE Sensitivity					μ V/m					AVERAGE Sensitivity		μ V/m					
Values in the formula for transform factor																	
Measuring antenna cable loss										Measuring antenna cable loss							
Measuring antenna attenuator loss										Measuring antenna attenuator loss							
Measuring antenna balun loss										Measuring antenna balun loss							
Mutual coupling and mismatch loss (30 - 180 MHz)										Mutual coupling and mismatch loss (30 - 180 MHz)							
Antenna factor of the measuring antenna										Antenna factor of the measuring antenna							

7.3.3.5 Statement of results

The results should be presented in tabular form as shown in table 12

Table 12: Overall results sheet

RECEIVER SENSITIVITY				Date:		PAGE 1 of 1			
Vertical Polarization				Horizontal Polarization					
MAXIMUM Usable Sensitivity				μ V/m		MAXIMUM Usable Sensitivity		μ V/m	
AVERAGE Usable Sensitivity				μ V/m		AVERAGE Usable Sensitivity		μ V/m	
Expanded uncertainty (95 %)				dB		Expanded uncertainty (95 %)		dB	

7.3.4 Measurement uncertainty for Receiver Sensitivity

A fully worked example illustrating the methodology to be used can be found in clause 4 of ETR 273-1-2 [7].

7.3.4.1 Uncertainty contributions: Stage 1: Determination of transform factor

The first stage (determining the transform factor) involves placing a measuring antenna as shown in figure 15 and determining the relationship between the signal generator output power level and the resulting field strength (the shaded areas in figure 15 represent components common to both stages of the test).

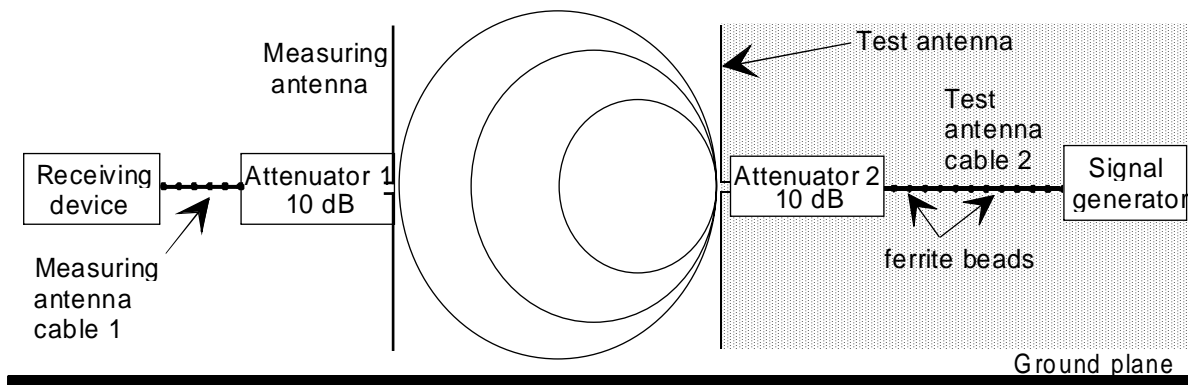

Figure 15: Stage 1: transform factor

All the uncertainty components which contribute to this stage of the test are listed in table 13. ETR 273-1-2 [7] should be consulted for the sources and/or magnitudes of the uncertainty contributions.

Table 13: Contributions for the transform factor

u_j or i	Description of uncertainty contributions	dB
<i>u_{j36}</i>	<i>mismatch: transmitting part</i>	
<i>u_{j37}</i>	<i>mismatch: receiving part</i>	
<i>u_{j38}</i>	<i>signal generator: absolute output level</i>	0,00
<i>u_{j39}</i>	<i>signal generator: output level stability</i>	
<i>u_{j19}</i>	<i>cable factor: measuring antenna cable</i>	
<i>u_{j19}</i>	<i>cable factor: test antenna cable</i>	
<i>u_{j41}</i>	<i>insertion loss: measuring antenna cable</i>	
<i>u_{j41}</i>	<i>insertion loss: test antenna cable</i>	0,00
<i>u_{j40}</i>	<i>insertion loss: measuring antenna attenuator</i>	
<i>u_{j40}</i>	<i>insertion loss: test antenna attenuator</i>	0,00
<i>u_{j47}</i>	<i>receiving device: absolute level</i>	
<i>u_{j16}</i>	<i>range length</i>	
<i>u_{j02}</i>	<i>reflectivity of absorbing material: measuring antenna to the test antenna</i>	
<i>u_{j44}</i>	<i>antenna: antenna factor of the measuring antenna</i>	
<i>u_{j45}</i>	<i>antenna: gain of the test antenna</i>	
<i>u_{j46}</i>	<i>antenna: tuning of the measuring antenna</i>	
<i>u_{j46}</i>	<i>antenna: tuning of the test antenna</i>	0,00
<i>u_{j22}</i>	<i>position of the phase centre: measuring antenna</i>	
<i>u_{j06}</i>	<i>mutual coupling: measuring antenna to its images in the absorbing material</i>	
<i>u_{j06}</i>	<i>mutual coupling: test antenna to its images in the absorbing material</i>	
<i>u_{j14}</i>	<i>mutual coupling: measuring antenna to its images in the ground plane</i>	
<i>u_{j14}</i>	<i>mutual coupling: test antenna to its images in the ground plane</i>	
<i>u_{j11}</i>	<i>mutual coupling: measuring antenna to the test antenna</i>	
<i>u_{j12}</i>	<i>mutual coupling: interpolation of mutual coupling and mismatch loss correction factors</i>	
<i>u_{i01}</i>	<i>random uncertainty</i>	

The standard uncertainties from table 13 should be combined by RSS in accordance with clause 5 of ETR 273-1-1 [6]. This gives the combined standard uncertainty (*u_c contributions from the Transform Factor*) for the transform factor in dB.

7.3.4.2 Uncertainty contributions: Stage 2: EUT measurement

The second stage (the EUT measurement) is to determine the minimum signal generator output level which produces the required response from the EUT as shown in figure 16 (the shaded areas represent components common to both stages of the test).

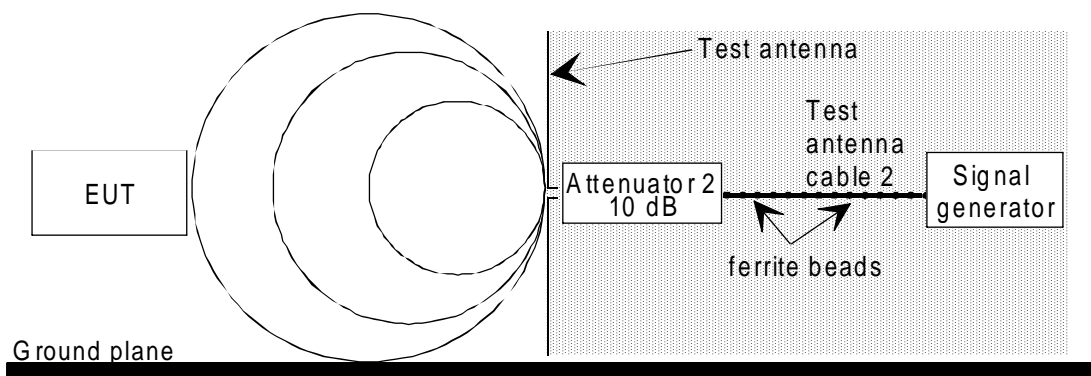

Figure 16: Stage 2: EUT measurement

All the uncertainty components which contribute to this stage of the test are listed in table 14. ETR 273-1-2 [7] should be consulted for the sources and/or magnitudes of the uncertainty contributions.

Table 14: Contributions from the EUT measurement

uj or i	Description of uncertainty contributions	dB
u_{j36}	mismatch: transmitting part	
u_{j38}	signal generator: absolute output level	0,00
u_{j39}	signal generator: output level stability	
u_{j19}	cable factor: test antenna cable	
u_{j41}	insertion loss: test antenna cable	0,00
u_{j40}	insertion loss: test antenna attenuator	0,00
u_{j20}	position of the phase centre: within the EUT volume	
u_{j21}	positioning of the phase centre: within the EUT over the axis of rotation of the turntable	
u_{j52}	EUT: modulation detection	
u_{j16}	range length	
u_{j01}	reflectivity of absorbing material: EUT to the test antenna	
u_{j45}	antenna: gain of the test antenna	0,00
u_{j46}	antenna: tuning of the test antenna	0,00
u_{j55}	EUT: mutual coupling to the power leads	
u_{j08}	mutual coupling: amplitude effect of the test antenna on the EUT	
u_{j04}	mutual coupling: amplitude effect of the absorbing material on the EUT	
u_{j13}	mutual coupling: EUT to its image in the ground plane	
u_{j06}	mutual coupling: test antenna to its images in the absorbing material	
u_{j14}	mutual coupling: test antenna to its image in the ground plane	
u_{j58}	Salty man/salty-lite: human simulation	
u_{j59}	Salty man/salty-lite: field enhancement and de-tuning of the EUT	
u_{i01}	random uncertainty	

The standard uncertainties from table 14 should be combined by RSS in accordance with clause 5 of ETR 273-1-1 [6]. This gives the combined standard uncertainty (u_c contribution from the EUT measurement) for the EUT measurement in dB.

7.3.4.3 Expanded uncertainty of the receiver sensitivity measurement

The combined uncertainty of the sensitivity measurement is the combination of the components outlined in subclauses 7.3.4.1 and 7.3.4.2. The components to be combined are u_c contribution from the Transform Factor and u_c contribution from the EUT measurement

$$u_c = \sqrt{u_{c \text{ contribution from the Transform Factor}}^2 + u_{c \text{ contribution from the EUT measurement}}^2} = _,_ \text{ dB}$$

The expanded uncertainty is $\pm 1,96 * u_c = \pm _,_ \text{ dB}$ at a 95 % confidence level.

7.3.5 Sensitivity tests (open area test site) (30 to 1 000 MHz)

7.3.5.1 Apparatus required

- digital voltmeter;
- ferrite beads;
- 10 dB attenuators;
- power supply;
- connecting cables;
- open area test site;
- salty man or salty-lite;
- test antenna (half wavelength dipole as detailed in ANSI C63.5 [1] recommended);
- measuring antenna (half wavelength dipole as detailed in ANSI C63.5 [1] recommended);
- RF Signal generator;
- receiving device (measuring receiver or spectrum analyser).

Additional requirements for analogue speech:

- AF source;
- SINAD meter (incorporating telephone psophometric weighting network);
- acoustic coupler (alternatively: audio load).

Additional requirements for bit stream:

- bit stream generator;
- bit error measuring test set.

Additional requirements for messages:

- acoustic coupler;
- message generator;
- response measuring test set.

The types and serial numbers of all items of test equipment should be recorded on page 1 of the log book results sheet (table 16).

NOTE: The half wavelength dipole antennas, incorporating matching/transforming baluns, for the procedure are available in the following bands: 20 MHz to 65 MHz, 65 MHz to 180 MHz, 180 MHz to 400 MHz, 400 MHz to 1 000 MHz. Constructional details are contained in ANSI C63.5 [1]. In the recommended antenna scheme for this band, a shortened dipole is used at all frequencies from 30 MHz to 80 MHz.

7.3.5.2 Method of measurement

- 1) The EUT should be mounted on the Salty man/Salty-lite at the height stated in the relevant Standard. It should be mounted in an orientation which matches that of its normal usage as declared by the manufacturer.

Determination of the transform factor for the test site

- 2) For this part of the test, it is necessary to position the measuring antenna such that its phase centre is at the same point that the phase centre of the EUT (mounted on the Salty man/Salty-lite) will occupy in the second part of the test. The precise point should always be, where possible, on the axis of rotation of the turntable but at a height above its mounting surface that should either be measured remotely or determined by sitting the complete assembly of Salty man/Salty-lite plus EUT on the turntable. The height above the turntable should be recorded on page 2 of the log book results sheet (table 16).

NOTE 1: If the position of the phase centre within the EUT is unknown, but its antenna is a single rod which is visible and vertical in normal usage, the axis of its antenna should be used for alignment with the axis of rotation of the turntable. The base of the antenna should be used for determining the height. If the phase centre is unknown and there is no visible antenna, the volume centre of the EUT should be used instead.

NOTE 2: The bulk of the Salty man/Salty-lite may offer little flexibility in positioning on the test site and some offset of the phase centre of the EUT from the axis of rotation might be unavoidable (see figure 17). Where an offset is unavoidable, its value should be entered on page 2 of the log book results sheet (table 16). If the overall positioning of the phase centre cannot be achieved without the dipole approaching closer than 0,25 m to the ground plane, the test should not be carried out.

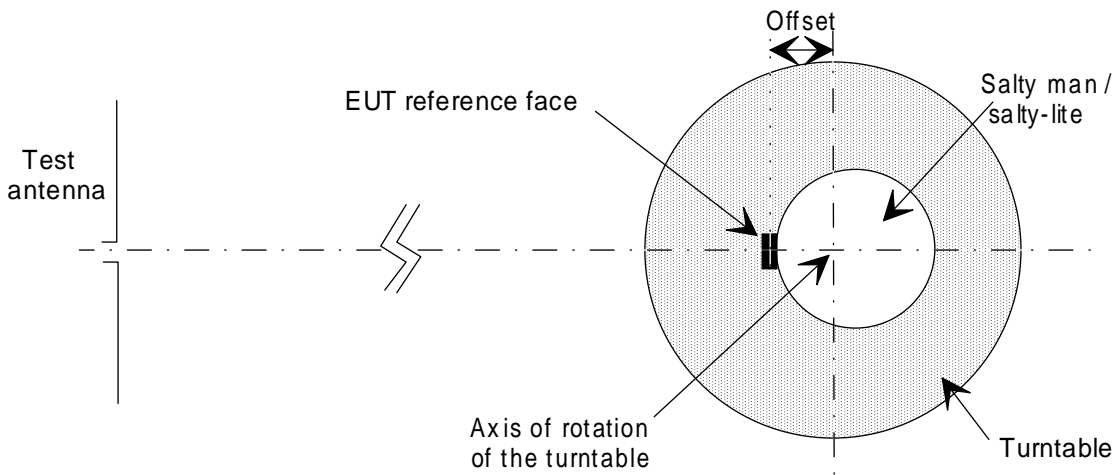

Figure 17: Illustration of offset from the axis of rotation

- 3) The measuring antenna (in the recommended scheme: a tuned ANSI C63.5 [1] half wavelength dipole for frequencies of 80 MHz and above, a shortened dipole for frequencies from 30 MHz to 80 MHz) should be adjusted to correspond to the nominal frequency of the EUT and positioned with its phase centre at the point identified in Step 2. It should be oriented for vertical polarization.

NOTE 3: For all frequencies below 80 MHz, a shortened dipole (as defined in subclause 7.1.3) should be used. The dipole arm length is defined from the centre of the balun block to the tip of the arm. From a fully extended state, each telescopic element, in turn, should be "pushed in" from the tip until the required length is obtained. The outermost section needs to fully compress before any of the others, and so on. Table 4 gives the dipole arm lengths and choice of balun for set frequencies. Where the test frequency does not correspond to a set frequency in the table, the arm length to be used should be determined by linear interpolation between the closest set values.

- 4) The measuring antenna should be connected via a 10 dB attenuator and the calibrated, ferrited coaxial cable associated with that end of the test site, to the receiving device.
- 5) The test antenna (identical to the measuring antenna) should be mounted on the antenna mast, tuned to the nominal frequency of the EUT and oriented for vertical polarization.
- 6) The test antenna should be connected via a 10 dB attenuator and the calibrated, ferrited coaxial cable associated with that end of the test site, to the signal generator whose output is unmodulated, (see figure 18. The signal generator should be tuned to the nominal frequency of the EUT.

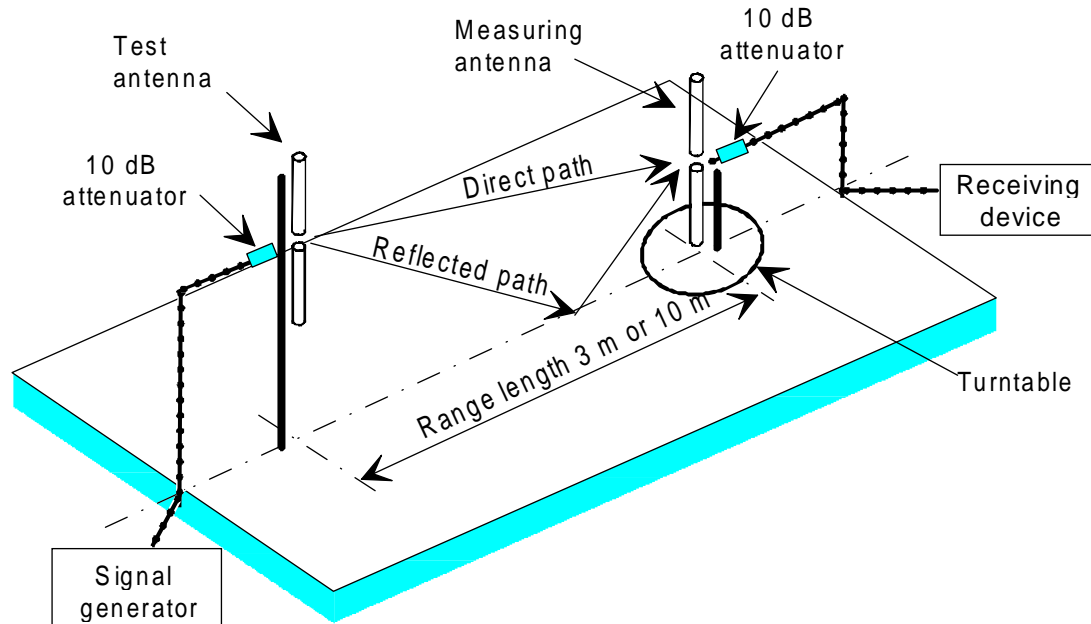

Figure 18: Equipment layout for the derivation of the transform factor during Sensitivity tests on an open area test site

- 7) The output level of the signal generator should be adjusted until a received signal level at least 20 dB above the noise floor is observed on the receiving device.
- 8) The test antenna should be raised and lowered through the specified range of heights whilst monitoring the received signal level on the receiving device. The test antenna should be positioned at the height corresponding to the maximum received signal. This height should be recorded on page 2 of the log book results sheet (table 16).

NOTE 4: The true maximum may lie beyond the top of the mast, in which case the maximum receivable level should be at the top of the height range.

- 9) The measuring antenna should be rotated in the horizontal plane until the maximum level is detected on the receiving device.

NOTE 5: This is to correct for possible misalignment of a directional beam i.e. dipoles used in horizontally polarized tests. This step can be omitted when dipoles are used in vertically polarized tests.

- 10) The maximum received signal level (dB μ V) appearing on the receiving device along with the output level from the signal generator (dBm) should be recorded on page 2 of the log book results sheet (table 16). The transform factor for the test site (i.e. a factor relating the output power level from the signal generator (dBm) to the resulting field strength (dB μ V/m) at the point of measurement) should be calculated according to the following formula:

$$\begin{aligned}
 \text{transform factor (dB)} &= \text{received signal level (dB}\mu\text{V)} \\
 &+ \text{measuring antenna cable loss} \\
 &+ \text{measuring antenna attenuator loss} \\
 &+ \text{measuring antenna balun loss} \\
 &+ \text{mutual coupling and mismatch loss correction factor (if applicable)} \\
 &+ \text{antenna factor of the measuring antenna} \\
 &- \text{signal generator output level (dBm)}
 \end{aligned}$$

NOTE 6: Guidance for deriving/calculating/finding the unknown values in the above formula for transform factor are given in table 15. These values should be entered on page 2 of the log book results sheet (table 16).

The resulting value for the transform factor should be entered on page 2 of the log book results sheet (table 16).

Table 15: Guidance for deriving transform factor

Values in the formula for transform factor	
Measuring antenna cable loss	Obtained directly from the calibration data
Measuring antenna attenuator loss	Obtained from calibration data
Measuring antenna balun loss	If not known from calibration data, the value should be taken as 0,30 dB
Mutual coupling and mismatch loss correction factor between the test antenna and the measuring antenna	For ANSI dipoles (30 to 180 MHz) values can be obtained from ETR 273-1-2 [7]. For frequencies > 180 MHz, this value is 0,00 dB. For non-ANSI dipoles this value is 0,00 dB
Antenna factor of the measuring antenna	For ANSI dipoles: Antenna factor = $20 \log_{10}(f) - 31,4$ dB dB/m (where f is the frequency in MHz) For other types the value can be obtained from calibration data

Sensitivity measurement on the EUT

- 11) The measuring antenna should be replaced on the turntable by the complete assembly of Salty man/Salty-lite plus EUT. The EUT should be positioned such that its phase centre is in the same place as formerly occupied by the phase centre of the measuring antenna.
- 12) The normal to the reference face of the EUT should point directly towards the test antenna. This is the 0° reference angle for this test. This orientation and mounting configuration should be recorded on page 1 of the log book results sheet (table 16).

For analogue speech:

- 13a) The EUT should be connected to the modulation detector (a SINAD meter incorporating a telephone psophometric weighting network) through an AF load or by an acoustic coupler which is made from low dielectric constant (i.e. less than 1,5) material(s) for EUTs not fitted with a direct connection (see figure 19).
- 13b) The signal generator output should be modulated with test modulation AM-1 (produced by the AF source) and its output level should be adjusted until a psophometrically weighted SINAD ratio of 20 dB is obtained from the EUT. The corresponding signal generator output power level should be recorded on page 2 of the log book results sheet (table 16).

13c) The Salty man/Salty-lite plus EUT complete assembly should be successively rotated through 45° in the horizontal plane to new testing angles of 45°, 90°, 135°, 180°, 225°, 270°, 315° (thereby covering the entire 360° in eight measurements). At each angle Step 13b should be repeated.

13d) The eight values of signal generator output power level resulting from Steps 13b and 13c should be converted into field strength values by firstly adding the transform factor to produce the field strength in dBμV/m and then secondly converting dBμV/m to μV/m i.e.:

- 1) field strength (dBμV/m) = signal generator level (dBm) + transform factor (dB);
- 2) field strength (μV/m) = $10^{(\text{field strength (dB}\mu\text{V/m)}/20)}$.

The resulting values in μV/m should be also entered on page 2 of the log book results sheet (table 16).

13e) The procedure should now resume with Step 14.

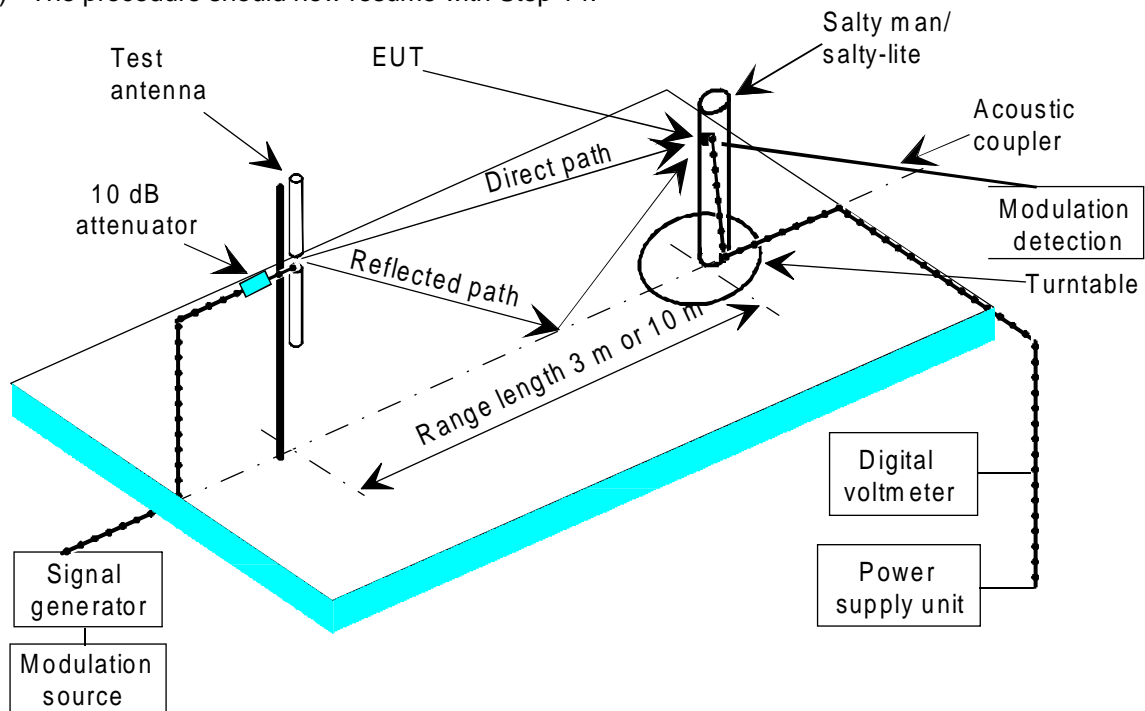

Figure 19: Open area test site set-up for sensitivity tests on the EUT

For bit stream:

13a) The EUT should be connected to the modulation detector (a bit error measuring test set, which should also receive a direct input from the bit stream generator) by a direct connection (see figure 19).

13b) The signal generator output should be modulated with test modulation DM-2 (produced by the bit stream generator) and its output level should be adjusted until a bit error ratio of 10^{-2} is obtained from the EUT. The corresponding signal generator output power level should be recorded on page 2 of the log book results sheet (table 16).

13c) The Salty man/Salty-lite and EUT complete assembly should be successively rotated through 45° in the horizontal plane to new testing angles of 45°, 90°, 135°, 180°, 225°, 270°, 315° (thereby covering the entire 360° in eight measurements). At each angle Step 13b should be repeated.

13d) The eight values of signal generator output power level resulting from Steps 13b and 13c should be converted into field strength values by firstly adding the transform factor to produce the field strength in dB μ V/m and then secondly converting dB μ V/m to μ V/m i.e.:

- 1) field strength (dB μ V/m) = signal generator level (dBm) + transform factor (dB);
- 2) field strength (μ V/m) = $10^{(\text{field strength (dB}\mu\text{V/m)}/20)}$.

The resulting values in μ V/m should be also entered on page 2 of the log book results sheet (table 16).

13e) The procedure should now resume with Step 14.

For messages

13a) The EUT should be connected to the modulation detector (a response measuring test set) via an acoustic coupler (pipe) which is made from low dielectric constant (i.e. less than 1,5) material(s) (see figure 19).

13b) The signal generator output should be modulated with test modulation DM-3 (produced by the message generator) and its output level should be adjusted until a message acceptance ratio of less than 10 % is obtained from the EUT.

13c) The test message should be transmitted repeatedly from the test antenna, whilst observing for each message whether a successful response is obtained. The output level of the signal generator should be increased by 2 dB for each occasion that a successful response is **not** obtained.

13d) Step 13c should be repeated until three consecutive successful responses are observed at the same output level from the signal generator. The output level from the signal generator should be recorded on page 2 of the log book results sheet (table 16).

13e) The output signal level from the signal generator should be reduced by 1 dB. The new signal level should be recorded on page 2 of the log book results sheet (table 16) and the response of the EUT observed.

13f) If a successful response is **not** obtained, the output signal level should be increased by 1 dB and the new level recorded in the results sheet. If a successful response **is** obtained, the input level should not be changed until three consecutive successful responses have been observed. In this case, the output signal level from the signal generator should be reduced by 1 dB and the new level recorded in the results sheet. No signal levels should be recorded unless preceded by a change of level.

13g) Step 13f should be repeated until a total of 10 recorded values for the signal generator output level have been entered on page 2 of the log book results sheet (table 16).

13h) The Salty man/Salty-lite and EUT complete assembly should be successively rotated through 45° in the horizontal plane to new testing angles of 45°, 90°, 135°, 180°, 225°, 270°, 315° (thereby covering the entire 360° in eight measurements). At each angle Steps 13b to 13g should be repeated.

13i) For each angle, the 10 recorded values of the signal generator output level (dBm) should be converted to field strength (μ V/m) by firstly adding the transform factor to produce the field strength in dB μ V/m and then secondly converting dB μ V/m to μ V/m i.e.:

- 1) field strength (dB μ V/m) = signal generator level (dBm) + transform factor (dB);
- 2) field strength (μ V/m) = $10^{(\text{field strength (dB}\mu\text{V/m)}/20)}$.

The resulting values in μ V/m should be also entered on page 2 of the log book results sheet (table 16).

- 13j) For each angle, the 10 new recorded values of field strength in $\mu\text{V}/\text{m}$ should be averaged according to the following formula:

$$\text{average field strength } (\mu\text{V}/\text{m}) = \sqrt{\left(\frac{10}{\sum_{i=1}^{10} \frac{1}{\text{field strength } (\mu\text{V}/\text{m})_i^2}} \right)}$$

The resulting eight average values should also be entered on page 2 of the log book results sheet (table 16).

- 13k) The procedure should continue with Step 14.
- 14) For the maximum sensitivity test only, the lowest of the eight values of field strength ($\text{dB}\mu\text{V}/\text{m}$) calculated during the multiple-stage Step 13 represents the minimum field strength to which the EUT responds. This lowest value of field strength ($\mu\text{V}/\text{m}$) should be entered on page 2 of the log book results sheet (table 16) as the maximum sensitivity.
- 15) For the average sensitivity test only, the average of the eight values of field strength ($\text{dB}\mu\text{V}/\text{m}$) calculated during the multiple-stage Step 13 represents the average field strength to which the EUT responds. This average value of field strength in $\mu\text{V}/\text{m}$ should now be calculated by the following:

$$\text{average field strength } (\mu\text{V}/\text{m}) = \sqrt{\left(\frac{8}{\sum_{i=1}^8 \frac{1}{\text{field strength } (\mu\text{V}/\text{m})_i^2}} \right)}$$

This average value of field strength ($\mu\text{V}/\text{m}$) should be entered on page 2 of the log book results sheet (table 16) as the average sensitivity.

- 16) Steps 2 to 15 should be repeated with both the test and measuring antennas oriented for horizontal polarization.

7.3.5.3 Procedure for completion of the results sheets

All the necessary processing of the measured results is carried out during the course of the test procedure. The only calculation that remains to be performed before the overall results sheet (table 17) can be completed is the determination of the expanded uncertainty of the measurement. This should be carried out in accordance with subclause 7.3.6 and the resulting value entered in the overall results sheet (table 17).

7.3.5.4 Log book entries

Table 16: Log book results sheet

RECEIVER SENSITIVITY		Date:		PAGE 1 of 2	
Temperature:..... °C		Humidity:.....%		Frequency:.....MHz	
Manufacturer of EUT:.....		Type No:.....		Serial No:.....	
Range length :.....					
Salty : Type:.....		Serial No:.....			
Test equipment item	Type No.	Serial No.	VSWR	Insertion loss	Antenna factor
Test antenna				N/A	
Test antenna attenuator					N/A
Test antenna cable					N/A
Measuring antenna				N/A	
Measuring antenna attenuator					N/A
Measuring antenna cable					N/A
Ferrite beads			N/A	N/A	N/A
Receiving device				N/A	N/A
Signal generator				N/A	N/A
Digital voltmeter			N/A	N/A	N/A
Power supply			N/A	N/A	N/A
Audio frequency source (if applicable)			N/A	N/A	N/A
SINAD meter (if applicable)			N/A	N/A	N/A
Audio frequency load (if applicable)			N/A	N/A	N/A
Bit stream generator (if applicable)			N/A	N/A	N/A
Bit error measuring test set (if applicable)			N/A	N/A	N/A
Acoustic coupler (if applicable)			N/A	N/A	N/A
Message generator (if applicable)			N/A	N/A	N/A
Response measuring test set (if applicable)			N/A	N/A	N/A
Mounting configuration of EUT					

(continued)

Table 16 (continued): Log book results sheet

RECEIVER SENSITIVITY (analogue speech)										Date:		PAGE 2 of 2														
Vertical polarization					Horizontal polarization																					
Height of the test antenna					m					Height of the test antenna		m														
Offset from the axis of rotation					m					Offset from the axis of rotation		m														
Received signal level					dB μ V					Received signal level		dB μ V														
Output level from signal generator					dBm					Output level from signal generator		dBm														
Transform factor					dB					Transform factor		dB														
Signal generator level (dBm) against angle for 20 dB SINAD										Signal generator level (dBm) against angle for 20 dB SINAD																
	0°	45°	90°	135°	180°	225°	270°	325°			0°	45°	90°	135°	180°	225°	270°	325°								
level									level										level							
Conversion to μ V/m										Conversion to μ V/m																
	0°	45°	90°	135°	180°	225°	270°	325°			0°	45°	90°	135°	180°	225°	270°	325°								
level									level										level							
MAXIMUM Sensitivity					μ V/m					MAXIMUM Sensitivity					μ V/m											
AVERAGE Sensitivity					μ V/m					AVERAGE Sensitivity					μ V/m											
Values in the formula for transform factor																										
Measuring antenna cable loss										Measuring antenna cable loss																
Measuring antenna attenuator loss										Measuring antenna attenuator loss																
Measuring antenna balun loss										Measuring antenna balun loss																
Mutual coupling and mismatch loss (30 - 180 MHz)										Mutual coupling and mismatch loss (30 - 180 MHz)																
Antenna factor of the measuring antenna										Antenna factor of the measuring antenna																

RECEIVER SENSITIVITY (bit stream)										Date:		PAGE 2 of 2														
Vertical polarization					Horizontal polarization																					
Height of the test antenna					m					Height of the test antenna		m														
Offset from the axis of rotation					m					Offset from the axis of rotation		m														
Received signal level					dB μ V					Received signal level		dB μ V														
Output level from signal generator					dBm					Output level from signal generator		dBm														
Transform factor					dB					Transform factor		dB														
Signal generator level (dBm) against angle for 10 ⁻² BER										Signal generator level (dBm) against angle for 10 ⁻² BER																
	0°	45°	90°	135°	180°	225°	270°	325°			0°	45°	90°	135°	180°	225°	270°	325°								
level									level										level							
Conversion to μ V/m										Conversion to μ V/m																
	0°	45°	90°	135°	180°	225°	270°	325°			0°	45°	90°	135°	180°	225°	270°	325°								
level									level										level							
MAXIMUM Sensitivity					μ V/m					MAXIMUM Sensitivity					μ V/m											
AVERAGE Sensitivity					μ V/m					AVERAGE Sensitivity					μ V/m											
Values in the formula for transform factor																										
Measuring antenna cable loss										Measuring antenna cable loss																
Measuring antenna attenuator loss										Measuring antenna attenuator loss																
Measuring antenna balun loss										Measuring antenna balun loss																
Mutual coupling and mismatch loss (30 - 180 MHz)										Mutual coupling and mismatch loss (30 - 180 MHz)																
Antenna factor of the measuring antenna										Antenna factor of the measuring antenna																

(continued)

Table 16 (concluded): Log book results sheet

RECEIVER SENSITIVITY (messages)									Date:									PAGE 2 of 2								
Vertical polarization									Horizontal polarization																	
Height of the test antenna				m					Height of the test antenna				m													
Offset from the axis of rotation				m					Offset from the axis of rotation				m													
Received signal level				dB μ V					Received signal level				dB μ V													
Output level from signal generator				dBm					Output level from signal generator				dBm													
Transform factor				dB					Transform factor				dB													
Signal generator level (dBm) against angle									Signal generator level (dBm) against angle																	
level	0°	45°	90°	135°	180°	225°	270°	325°	level	0°	45°	90°	135°	180°	225°	270°	325°									
1									1																	
2									2																	
3									3																	
4									4																	
5									5																	
6									6																	
7									7																	
8									8																	
9									9																	
10									10																	
Conversion to μ V/m									Conversion to μ V/m																	
level	0°	45°	90°	135°	180°	225°	270°	325°	level	0°	45°	90°	135°	180°	225°	270°	325°									
1									1																	
2									2																	
3									3																	
4									4																	
5									5																	
6									6																	
7									7																	
8									8																	
9									9																	
10									10																	
Ave.									Ave.																	
MAXIMUM Sensitivity				μ V/m					MAXIMUM Sensitivity				μ V/m													
AVERAGE Sensitivity				μ V/m					AVERAGE Sensitivity				μ V/m													
Values in the formula for transform factor																										
Measuring antenna cable loss									Measuring antenna cable loss																	
Measuring antenna attenuator loss									Measuring antenna attenuator loss																	
Measuring antenna balun loss									Measuring antenna balun loss																	
Mutual coupling and mismatch loss (30 - 180 MHz)									Mutual coupling and mismatch loss (30 - 180 MHz)																	
Antenna factor of the measuring antenna									Antenna factor of the measuring antenna																	

7.3.5.5 Statement of results

The results should be presented in tabular form as shown in table 17.

Table 17: Overall results sheet

RECEIVER SENSITIVITY				Date:				PAGE 1 of 1			
Vertical polarization				Horizontal polarization							
MAXIMUM Usable Sensitivity		μ V/m		MAXIMUM Usable Sensitivity		μ V/m					
AVERAGE Usable Sensitivity		μ V/m		AVERAGE Usable Sensitivity		μ V/m					
Expanded uncertainty (95 %)		dB		Expanded uncertainty (95 %)		dB					

7.3.6 Measurement uncertainty for Receiver Sensitivity

A fully worked example illustrating the methodology to be used can be found in clause 4 of ETR 273-1-2 [7]

7.3.6.1 Uncertainty contributions: Stage 1: Determination of transform factor

The first stage (determining the transform factor) involves placing a measuring antenna as shown in figure 15 and determining the relationship between the signal generator output power level and the resulting field strength (the shaded areas in figure 15 represent components common to both stages of the test).

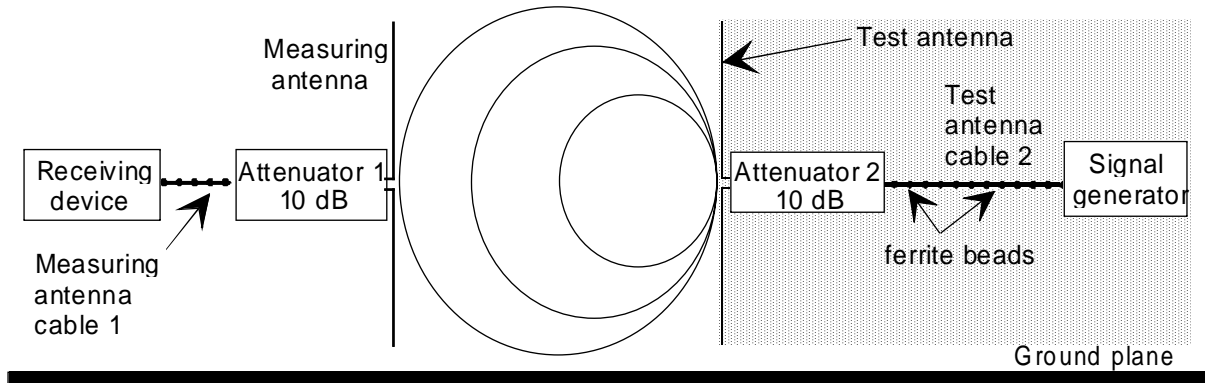

Figure 20: Stage 1: Transform factor

All the uncertainty components which contribute to this stage of the test are listed in table 13. ETR 273-1-1 [6] should be consulted for the sources and/or magnitudes of the uncertainty contributions.

Table 18: Contributions for the transform factor

uj or i	Description of uncertainty contributions	dB
u_{j36}	<i>mismatch: transmitting part</i>	
u_{j37}	<i>mismatch: receiving part</i>	
u_{j38}	<i>signal generator: absolute output level</i>	0,00
u_{j39}	<i>signal generator: output level stability</i>	
u_{j19}	<i>cable factor: measuring antenna cable</i>	
u_{j19}	<i>cable factor: test antenna cable</i>	
u_{j41}	<i>insertion loss: measuring antenna cable</i>	
u_{j41}	<i>insertion loss: test antenna cable</i>	0,00
u_{j40}	<i>insertion loss: measuring antenna attenuator</i>	
u_{j40}	<i>insertion loss: test antenna attenuator</i>	0,00
u_{j47}	<i>receiving device: absolute level</i>	
u_{j16}	<i>range length</i>	
u_{j44}	<i>antenna: antenna factor of the measuring antenna</i>	
u_{j45}	<i>antenna: gain of the test antenna</i>	
u_{j46}	<i>antenna: tuning of the measuring antenna</i>	
u_{j46}	<i>antenna: tuning of the test antenna</i>	0,00
u_{j22}	<i>position of the phase centre: measuring antenna</i>	
u_{j14}	<i>mutual coupling: measuring antenna to its images in the ground plane</i>	
u_{j14}	<i>mutual coupling: test antenna to its images in the ground plane</i>	
u_{j11}	<i>mutual coupling: measuring antenna to the test antenna</i>	
u_{j12}	<i>mutual coupling: interpolation of mutual coupling and mismatch loss correction factors</i>	
u_{i01}	<i>random uncertainty</i>	

The standard uncertainties from table 18 should be combined by RSS in accordance with ETR 273-1-1 [6]. This gives the combined standard uncertainty (u_c contributions from the Transform Factor) for the transform factor in dB.

7.3.6.2 Uncertainty contributions: Stage 2: EUT measurement

The second stage (the EUT measurement) is to determine the minimum signal generator output level which produces the required response from the EUT as shown in figure 21 (the shaded areas represent components common to both stages of the test).

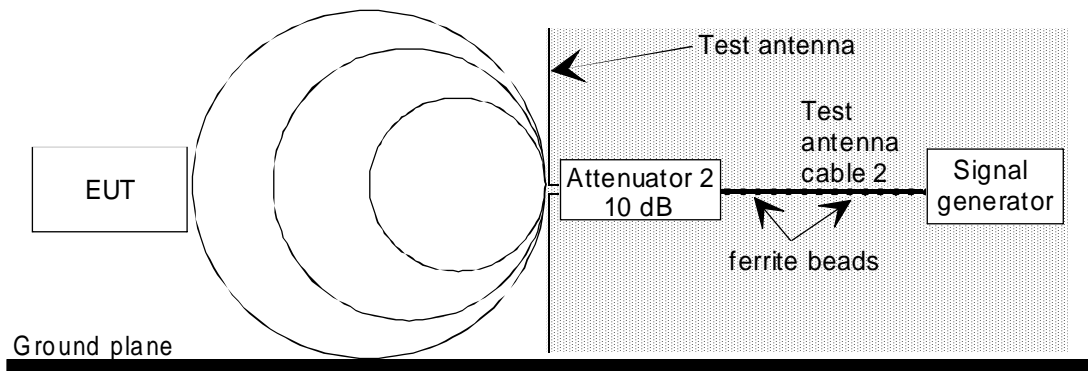

Figure 21: Stage 2: EUT measurement

All the uncertainty components which contribute to this stage of the test are listed in table 19. ETR 273-1-2 [7] should be consulted for the sources and/or magnitudes of the uncertainty contributions.

Table 19: Uncertainty contributions from the EUT measurement

uj or i	Description of uncertainty contributions	dB
u_{j36}	<i>mismatch: transmitting part</i>	
u_{j38}	<i>signal generator: absolute output level</i>	0,00
u_{j39}	<i>signal generator: output level stability</i>	
u_{j19}	<i>cable factor: test antenna cable</i>	
u_{j41}	<i>insertion loss: test antenna cable</i>	0,00
u_{j40}	<i>insertion loss: test antenna attenuator</i>	0,00
u_{j20}	<i>position of the phase centre: within the EUT volume</i>	
u_{j21}	<i>positioning of the phase centre: within the EUT over of the axis of rotation of the turntable</i>	
u_{j52}	<i>EUT: modulation detection</i>	
u_{j16}	<i>range length</i>	
u_{j45}	<i>antenna: gain of the test antenna</i>	0,00
u_{j46}	<i>antenna: tuning of the test antenna</i>	0,00
u_{j55}	<i>EUT: mutual coupling to the power leads</i>	
u_{j08}	<i>mutual coupling: amplitude effect of the test antenna on the EUT</i>	
u_{j13}	<i>mutual coupling: EUT to its image in the ground plane</i>	
u_{j14}	<i>mutual coupling: test antenna to its image in the ground plane</i>	
u_{j58}	<i>Salty man/salty-lite: human simulation</i>	
u_{j59}	<i>Salty man/salty-lite: field enhancement and de-tuning of the EUT</i>	
u_{i01}	<i>random uncertainty</i>	

The standard uncertainties from table 19 should be combined by RSS in accordance with ETR 273-1-1 [6]. This gives the combined standard uncertainty (u_c contribution from the EUT measurement) for the EUT measurement in dB.

7.3.6.3 Expanded uncertainty of the receiver sensitivity measurement

The combined uncertainty of the sensitivity measurement is the combination of the components outlined in subclauses 7.3.6.1 and 7.3.6.2. The components to be combined are u_c contribution from the Transform Factor and u_c contribution from the EUT measurement.

$$u_c = \sqrt{u_c^2 \text{ contribution from the Transform Factor} + u_c^2 \text{ contribution from the EUT measurement}} = _, _ \text{ dB}$$

The expanded uncertainty is $\pm 1,96 * u_c = \pm _, _ \text{ dB}$ at a 95 % confidence level.

7.3.7 Co-channel rejection

This test is not usually performed on a Salty man/Salty-lite and is therefore not considered here.

7.3.8 Adjacent channel selectivity

This test is not usually performed on a Salty man/Salty-lite and is therefore not considered here.

7.3.9 Intermodulation immunity

This test is not usually performed on a Salty man/Salty-lite and is therefore not considered here.

7.3.10 Blocking immunity or desensitization

This test is not usually performed on a Salty man/Salty-lite and is therefore not considered here.

7.3.11 Spurious response rejection

This test is not usually performed on a Salty man/Salty-lite and is therefore not considered here.

Annex A (informative): Bibliography

- "Advanced National certificate mathematics", PEDOE, Hodder and Stoughton Volumes I and II.
- "Antenna engineering handbook", R. C. Johnson, H. Jasik.
- "Antennas and radio wave propagation", R. E. Collin, McGraw Hill.
- "Antennas", John D. Kraus, Second edition, McGraw Hill.
- "Antenna theory", C. Balanis, J. E. Wiley 1982.
- "Chambers Science and Technology dictionary", 1988. Published by Chambers Cambridge.
- "A designers guide to shielding", Hewlett Packard: RF and microwave measurement symposium and exhibition.
- "Analysis of trials on Artificial Human Body", I. L. Gallan and P. R. Brown Interference technology international consultants ltd. Contract ref MC/078.
- "Calculation of site attenuation from antenna factors" A. A. Smith Jr, RF German and J B Pate. IEEE transactions EMC. Vol. EMC 24 pp 301-316 Aug 1982.
- "Computer simulation and measurements of electromagnetic fields close to phantom Humans", Electricity and magnetism in biology and medicine by Martin Blank, Ed 1993 San Francisco Press.
- "Control of errors on open area test sites", A. A. Smith Jnr. EMC technology October 1982 page 50-58.
- "Digital Communications", John G. Proakis, McGraw-Hill International Editions, second edition
- ETR 027: "Methods of measurement for private mobile radio equipment"
- ETR 028: "Uncertainties in the measurement of mobile radio equipment characteristics".
- "The expression of uncertainty in electrical measurement", B3003, November 1987 National Measurement Accreditation Service (NAMAS).
- "Fundamentals of RF and Microwave Power Measurements", Hewlett Packard: Application note 64-1 August 1977.
- "The gain resistance product of the half-wave dipole", W. Scott Bennet Proceedings of IEEE vol. 72 No. 2 Dec 1984 pp 1824-1826.
- "Getting better results from an open area test site", Joseph DeMarinus.
- "Guide to the evaluation and expression of the uncertainties associated with the results of electrical measurements", Ministry of Defence: 00-26/Issue 2: September 1988.
- "Guide to the Expression of Uncertainty in Measurement" (International Organization for standardization, Geneva, Switzerland, 1995).
- "Measurement uncertainty generally", Statens Tekniske Provenaevn, The Danish Accreditation Committee (STP). June 1988 (Danish).
- "The new IEEE standard dictionary of electrical and electronic terms". Fifth edition, IEEE Piscataway, NJ USA 1993.

- "*Specifications for equipment's for use in the Land Mobile Service*" CEPT Recommendation T/R 24-01.
- "*Techniques for measuring narrowband and broadband EMI signals using spectrum analysers*", Hewlett Packard RF and microwave measurement symposium and exhibition.
- "*Uncertainties of Measurement for NATLAS electrical testing laboratories. NAMAS policy and general notes*", National Testing Laboratory Accreditation Scheme (NATLAS), NIS20 July 1986 (English).
- "*Use of Simulated Human Bodies in pager receiver sensitivity measurements*", K.Siwiaak and W.Elliott III. Southcom /92 conference, Orlando 1992. pp 189/92.
- "*Usikkerhed pa maleresultater*" (Per Bennich, Institute for Product Development : "Uncertainty of measured results"). October 1988. (Danish).
- "*Standard site method for determining antenna factors*", A. A. Smith Jr. IEEE transactions EMC. Vol EMC 24 pp 316-322 Aug 1982.
- 50(161) IEC 1990.
- "*Radiowave propagation and antennas for personal communications*" K. Siwiaak, Artech House Publications.
- "*The telecommunications factbook and illustrated dictionary*", Kahn, Delmar publications Inc. New York 1992.
- "*Vocabulary of metrology*", British standard Institution (BSI) : PD 6461: Part 2: September 1980.
- "*Wave transmission*", F. R. Conner, Arnold 1978.

History

Document history	
February 1998	First Edition