



ETSI
TECHNICAL
REPORT

ETR 080

July 1993

Source: ETSI TC-TM

Reference: DTR/TM-03002

ICS: 33.020

Key words: ISDN, transmission

**Transmission and Multiplexing (TM);
Integrated Services Digital Network (ISDN) basic rate access;
Digital transmission system on metallic local lines**

ETSI

European Telecommunications Standards Institute

ETSI Secretariat

Postal address: F-06921 Sophia Antipolis CEDEX - FRANCE

Office address: 650 Route des Lucioles - Sophia Antipolis - Valbonne - FRANCE

X.400: c=fr, a=atlas, p=etsi, s=secretariat - **Internet:** secretariat@etsi.fr

Tel.: +33 92 94 42 00 - Fax: +33 93 65 47 16

Copyright Notification: No part may be reproduced except as authorized by written permission. The copyright and the foregoing restriction extend to reproduction in all media.

© European Telecommunications Standards Institute 1993. All rights reserved.

Contents

Foreword	9
1 Scope	11
1.1 Objectives	12
1.2 References	12
1.3 Symbols and abbreviations	13
2 Functions	15
2.1 B-channel	15
2.2 D-channel	15
2.3 Bit timing	15
2.4 Octet timing	15
2.5 Frame alignment	15
2.6 Activation from LT or NT1	15
2.7 Deactivation	16
2.8 Power feeding	16
2.9 Operations and maintenance	16
3 Transmission medium	16
3.1 Description	16
3.2 Minimum ISDN requirements	17
3.3 DLL physical characteristics	17
3.4 DLL characteristics	18
3.4.1 Principal Characteristics	18
3.4.2 Crosstalk	19
3.4.3 Unbalance about earth	19
3.4.4 Impulse noise	19
3.4.5 Micro interruptions	19
4 System performance	19
4.1 Performance requirements	19
4.2 Performance measurements	20
4.2.1 DLL physical models	21
4.2.2 Intrasystem crosstalk	23
4.2.3 Impulse noise modelling	23
4.2.3.1 Types of impulsive noise	23
4.2.3.2 Measurement arrangement	24
4.2.4 Performance tests	25
4.3 Unbalance about earth	26
4.3.1 Longitudinal conversion loss	26
4.3.2 Longitudinal output voltage	27
5 Transmission method	28
6 Activation/deactivation	28
6.1 General	28
6.2 Physical representation of signals	28
7 Operation and maintenance	28
7.1 Operation and maintenance functions	28
7.2 C _L channel	29
7.2.1 C _L channel definition	29
7.2.2 C _L channel requirements	29
7.3 Metallic loop testing	29
8 Power feeding	29

8.1	General.....	29
8.2	Power feeding functions.....	29
8.2.1	Power feeding of the REG.....	29
8.2.2	Power feeding of the NT1.....	29
8.2.3	Power feeding of the user network interface.....	29
8.3	DLL resistance.....	30
8.4	Wetting current.....	30
8.5	LT aspects.....	30
8.5.1	Safety.....	30
8.5.2	Feeding voltage from the LT.....	30
8.6	Power requirements of NT1 and regenerator.....	30
8.6.1	Power requirements of NT1.....	30
8.6.2	Power requirement of regenerator.....	31
8.6.3	Feeding voltage to the NT1.....	31
8.6.4	Voltage drop across the REG.....	31
8.7	Current transient limitation.....	31
8.8	DC and low frequency AC termination of NT1 and REG.....	31
9	Environmental conditions.....	31
9.1	Climatic conditions.....	31
9.2	Safety.....	31
9.3	Overvoltage protection.....	32
9.4	EMC.....	32
Annex A:	Definition of a system using 2B1Q line code.....	33
A.1	Line code.....	33
A.2	Line baud rate.....	33
A.2.1	NT1 clock tolerance.....	33
A.2.2	LT clock tolerance.....	33
A.2.3	REG clock tolerance.....	33
A.3	Frame structure.....	33
A.3.1	Frame length.....	33
A.3.2	Bit allocation in direction LT to NT1.....	33
A.3.3	Bit allocation in direction NT1 to LT.....	33
A.4	Frame word.....	35
A.4.1	Frame word in direction LT to NT1.....	35
A.4.2	Frame word in direction NT1 to LT.....	35
A.5	Frame alignment procedure.....	35
A.6	Multiframe.....	35
A.6.1	Multiframe word in direction NT1 to LT.....	35
A.6.2	Multiframe word in direction LT to NT1.....	35
A.7	Frame offset between LT to NT1 and NT1 to LT frames.....	35
A.8	C _L channel.....	35
A.8.1	Bit rate.....	35
A.8.2	Structure.....	35
A.8.3	Protocol and procedures.....	36
A.8.3.1	Error monitoring function.....	37
A.8.3.1.1	Cyclic redundancy check.....	37
A.8.3.1.2	CRC algorithms.....	37
A.8.3.1.3	Bits covered by the CRC.....	39
A.8.3.2	Other C _L channel functions.....	39
A.8.3.2.1	Far end block error bit, mandatory.....	39
A.8.3.2.2	The ACT bit, mandatory.....	39
A.8.3.2.3	The DEA bit, mandatory.....	39
A.8.3.2.4	NT1 power status bits.....	39

	A.8.3.2.5	NT1 Test Mode (NTM) indicator bit	39
	A.8.3.2.6	Cold-Start-Only (CSO) bit	39
	A.8.3.2.7	DLL-Only-Activation (UOA) bit	39
	A.8.3.2.8	S/T-Interface-Activity-Indicator (SAI) bit	39
	A.8.3.2.9	Alarm Indicator Bit (AIB)	40
	A.8.3.2.10	Network Indicator Bit (NIB) for network use	40
	A.8.3.2.11	Reserved bits	40
	A.8.3.3	Embedded Operations Channel (EOC) functions	40
	A.8.3.3.1	EOC frame	40
	A.8.3.3.2	Mode of operation	41
	A.8.3.3.3	Addressing	41
	A.8.3.3.4	Definition of required EOC functions	42
	A.8.3.3.5	Codes for required EOC functions	42
A.9	Scrambling		43
A.10	Start-up and control		45
	A.10.1	Signals used for start-up and control	46
	A.10.1.1	Signals during start-up	46
	A.10.1.2	Line rate during start-up	47
	A.10.1.3	Start-up sequence	47
	A.10.1.4	Wake-up	47
	A.10.1.5	Progress indicators	48
	A.10.1.5.1	Start-up	48
	A.10.1.5.2	Deactivation	48
	A.10.2	Timers	48
	A.10.3	Description of the start-up procedure	49
	A.10.3.1	Start-up from customer equipment	49
	A.10.3.2	Start-up from the network	49
	A.10.3.3	Sequence charts	49
	A.10.3.4	Transparency	52
	A.10.4	State transition table for the NT1	52
	A.10.5	State transition table for the LT	52
	A.10.6	Activation times	60
A.11	Jitter		61
	A.11.1	NT1 input signal jitter tolerance	61
	A.11.2	NT1 output jitter limitations	62
	A.11.3	LT input signal jitter tolerance	62
	A.11.4	LT output jitter and synchronisation	62
	A.11.5	REG jitter tolerance and output jitter limitations	62
	A.11.6	Test conditions for jitter measurements	62
A.12	Transmitter output characteristics of NT1, REG and LT		63
	A.12.1	Pulse amplitude	63
	A.12.2	Pulse shape	63
	A.12.3	Signal power	63
	A.12.4	Power spectral density	64
	A.12.5	Transmitter linearity	64
	A.12.5.1	Requirements	64
	A.12.5.2	Linearity test method	64
A.13	Transmitter/receiver termination		66
	A.13.1	Impedance	66
	A.13.2	Return loss	66
	A.13.3	Unbalance about earth	67
	A.13.3.1	Longitudinal conversion loss	67
Appendix I (to Annex A):	Extension functions of the system using 2B1Q line code		68
I-1	Introduction		68
I-2	NT1 Power status bits		68

I-3	NTM bit	68
I-4	CSO bit	68
I-5	UOA bit	69
I-6	SAI bit	69
I-7	AIB	69
	Appendix II (to Annex A): Discussion of EOC addressing	78
II-1	Addresses 1 through 6 (intermediate elements).....	78
II-2	Action of intermediate elements	78
II-3	Action of NT	78
II-4	Summary	79
	Annex B: Definition of a system using MMS 43 line code.....	80
B.1	Line code	80
B.2	Symbol rate.....	80
B.2.1	Clock symbol requirements.....	80
B.2.1.1	NT1 free running clock accuracy	80
B.2.1.2	LT clock tolerance	80
B.3	Frame structure	81
B.3.1	Frame length	81
B.3.2	Symbol allocation LT to NT1	81
B.3.3	Symbol allocation NT1 to LT	81
B.4	Frame word.....	81
B.4.1	Frame word in direction LT to NT1.....	81
B.4.2	Frame word in direction NT1 to LT.....	81
B.5	Frame alignment procedure	81
B.6	Multiframe	81
B.7	Frame offset at NT1.....	82
B.8	C _L channel	82
B.8.1	Bit rate	82
B.8.2	Structure.....	82
B.8.3	Protocols and procedures	82
B.9	Scrambling.....	83
B.10	Activation/deactivation	83
B.10.1	Signals used for activation	84
B.10.2	Definition of internal timers.....	85
B.10.3	Description of the activation procedure.....	85
B.10.4	NT1 state transition table	87
B.10.5	LT state transition table.....	88
B.10.6	Activation times	89
B.11	Jitter	90
B.11.1	Limits of maximum tolerable input jitter.....	90
B.11.2	Output jitter of NT1 in absence of input jitter.....	90

B.11.3	Timing extraction jitter.....	90
B.11.4	Test conditions for jitter measurements.....	90
B.12	Transmitter output characteristics.....	91
B.12.1	Pulse amplitude.....	91
B.12.2	Pulse shape.....	91
B.12.3	Signal power.....	91
B.12.4	Power spectrum.....	92
B.12.5	Transmitter signal nonlinearity.....	92
B.13	Transmitter/receiver termination.....	92
B.13.1	Impedance.....	92
B.13.2	Return loss.....	92
B.13.3	Longitudinal conversion loss.....	93
Appendix III: Extension functions and requirements for a line system with MMS43 line code.....		93
Annex C: Detailed test cable characteristics.....		94
C.1	Parameters for test cables.....	94
C.1.1	Parameters of 0,4 mm PE cable.....	94
C.1.2	Parameters of 0,5 mm PE cable.....	95
C.1.3	Parameters of 0,6 mm PE cable.....	96
C.1.4	Parameters of 0,8 mm PE cable.....	97
C.1.5	Parameters of 0,32 mm PVC cable.....	98
C.1.6	Parameters of 0,4 mm PVC cable.....	99
C.1.7	Parameters of 0,63 mm PVC cable.....	100
C.2	Impedance plot of test loops.....	101
C.2.1	Impedance plot at 10 kHz.....	101
C.2.2	Impedance plot at 20 kHz.....	102
C.2.3	Impedance plot at 40 kHz.....	103
C.3	Frequency response of test loops.....	104
C.3.1	Frequency response of loop 2.....	104
C.3.2	Frequency response of loop 3.....	104
C.3.3	Frequency response of loop 4.....	105
C.3.4	Frequency response of loop 5.....	105
C.3.5	Frequency response of loop 6.....	106
C.3.6	Frequency response of loop 7.....	106
C.3.7	Frequency response of loop 8.....	107
History.....		108

Blank page

Foreword

ETSI Technical Reports (ETRs) are informative documents resulting from ETSI studies which are not appropriate for European Telecommunication Standard (ETS) or Interim European Telecommunication Standard (I-ETS) status. An ETR may be used to publish material which is either of an informative nature, relating to the use or application of ETSS or I-ETSS, or which is immature and not yet suitable for formal adoption as an ETS or I-ETS.

Blank page

1 Scope

This ETSI Technical Report (ETR) covers the characteristics and parameters of a digital transmission system at the network side of the NT1 to form part of the access digital section for the Integrated Services Digital Network (ISDN) basic rate access using echo cancellation method.

It is based on CCITT Recommendation G.961 [1].

The system will support:

- full duplex; and
- bit sequence independent,

transmission of two B-channels and one D-channel as defined in CCITT Recommendation I.412 [2] and the supplementary functions of the access digital section defined in ETR 001 [3], which is based on CCITT Recommendation I.603 [4], for operation and maintenance.

The terminology used in this ETR is very specific and not contained in the relevant terminology Recommendations. Therefore, Annex B to CCITT Recommendation G.960 [5] provides a number of terms and definitions used in this ETR.

Figure 1 shows the boundaries of the digital transmission system in relation to the access digital section.

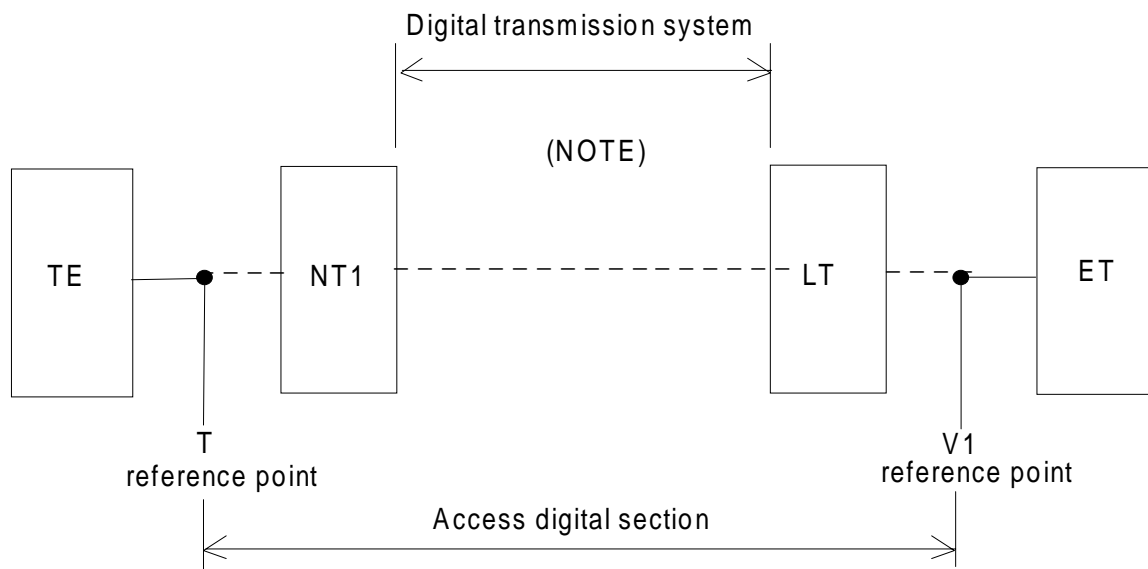

NOTE: In this ETR, digital transmission system refers to a line system using metallic local lines. The use of one intermediate regenerator (REG) may be required.

Figure 1: Access digital section and transmission system boundaries

The concept of the access digital section is used in order to allow a functional and procedural description and a definition of the network requirements.

NOTE: The reference points T and V₁ are not identical and therefore the access digital section is not symmetric.

The concept of a digital transmission system is used in order to describe the characteristics of an implementation, using a specific medium, in support of the access digital section.

1.1 Objectives

Considering that the access digital section between the local exchange and the customer is one key element of the successful introduction of ISDN into the network, the following requirements for the specification have been taken into account:

- to operate on existing 2-wire unloaded lines, open wires being excluded;
- the objective is to achieve 100% cable fill for ISDN basic access without pair selection, cable rearrangements or removal of Bridged Taps (BTs);
- the objective to be able to extend ISDN basic access provided services to the majority of customers without the use of regenerators. In the remaining few cases, special arrangements may be required;
- coexistence in the same cable unit with most of the existing services like telephony and voice band data transmission;
- various national regulations concerning Electro-Magnetic Compatibility (EMC) should be taken into account;
- power feeding from the network under normal or restricted modes via the basic access shall be provided;
- the capability to support maintenance functions shall be provided;

1.2 References

The following references are used within this ETR:

- [1] CCITT Recommendation G.961 (1988): "Digital transmission system on metallic local lines for ISDN basic rate access".
- [2] CCITT Recommendation I.412 (1988): "ISDN user-network interfaces - Interface structures and access capabilities".
- [3] ETR 001 (1990): "ISDN Customer access maintenance".
- [4] CCITT Recommendation I.603 (1988): "Application of maintenance principles to ISDN basic accesses".
- [5] CCITT Recommendation G.960 (1988): "Digital section for ISDN basic rate access".
- [6] CCITT Recommendation G.821 (1988): "Error performance of an international digital connection forming part of an integrated services digital network".
- [7] CCITT Recommendation O.121 (1984): "Measuring arrangement to access the degree of unbalance about earth".
- [8] prETS 300 297 (1992): "Integrated Services Digital Network (ISDN); Access digital section for ISDN basic rate".
- [9] ETS 300 012 (1991): "ISDN Basic user-network interface. Layer 1 specification and test principles".
- [10] CCITT Recommendation K.12: "Characteristics of gas discharge tubes for the protection of telecommunications installations".
- [11] CCITT Recommendation K.20: "Resistibility of telecommunication switching equipment to overvoltages and overcurrents".
- [12] CCITT Recommendation K.21: "Resistibility of subscribers' terminals to overvoltages and overcurrents".

- [13] ETS 300 047 (1992): "Integrated Services Digital Network (ISDN); Basic access - safety and protection, Part 4: Interface Ib - safety, Part 5: Interface Ib - protection".
- [14] prEN 50096 (1992): "Integrated Services Digital Network (ISDN); Equipment with ISDN user-network interface at basic and primary-rate, EMC requirements".
- [15] ETS 300 019: "Equipment Engineering (EE); Environmental conditions and tests for telecommunications equipments".
- [16] ETR 012: "Terminal Equipment (TE): Safety categories and protection levels at various interfaces for telecommunication equipment in customer premises".
- [17] EN 41 003 (1991): "Particular safety requirements for equipment to be connected to telecommunication networks".
- [18] EN 609 50 (1988): "Safety of information technology equipment including electrical business equipment".
- [19] CCITT Recommendation K.17 (1988): "Tests on power-fed repeaters using solid state devices in order to check the arrangement for protection from external interference".
- [20] CCITT Recommendation G.823 (1988): "The control of jitter and wander within digital networks which are based on the 2048 kbit/s hierarchy".

1.3 Symbols and abbreviations

For the purposes of this ETR, the following symbols and abbreviations apply:

REG	Regenerator
BT	Bridged Tap
EMC	Electro-Magnetic Compatibility
DTS	Digital Transmission System
ET	Exchange Termination
DLL	Digital Local Line
ISDN	Integrated Services Digital Network
MDF	Main Distribution Frame
CCP	Cross Connection Point
SDP	Subscriber Distribution Point
NEXT	Near End Crosstalk
PSL	Power Sum Loss
LCL	Longitudinal Conversion Loss
rms	root mean squared
BER	Bit Error Rate
ECH	Echo Cancellation Hybrid

EC	Echo Cancellor
NT	Network Termination
LT	Line Termination
DC	Direct Current
AC	Alternating Current
TNV	Telecommunication Network Voltage
2B1Q	2 Binary, 1 Quaternary
ppm	parts per million
FW	Frame Word
IFW	Inverted Frame Word
CRC	Cyclic Redundancy Check
FEBE	Far End Block Error
NTM	NT1 Test Mode
CSO	Cold-Start-Only
UOA	DLL-Only-Activation
SAI	S/T-interface-Activity Indicator
AIB	Alarm Indicator Bit
NIB	Network Indicator Bit
EOC	Embedded Operations Channel
TE	Terminal Equipment
UI	Unit Interval
A/D	Analogue to Digital
DSL	Digital Subscriber Line
MMS	Modified Monitoring State
FE	Failure Element
UNI	User Network Interface

2 Functions

Figure 2 shows the functions of the digital transmission system on metallic local lines.

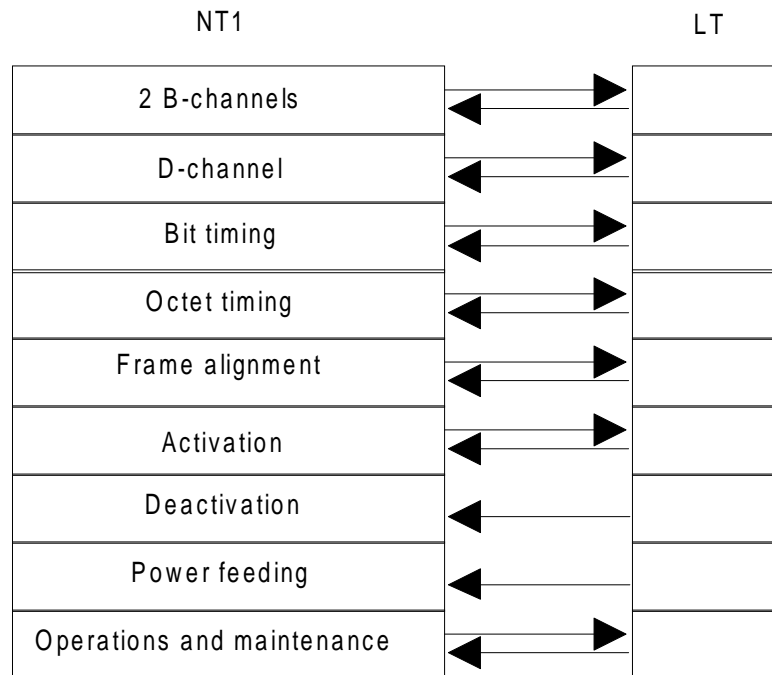

NOTE: The optional use of one regenerator shall be foreseen.

Figure 2: Functions of the digital transmission system

2.1 B-channel

This function provides, for each direction of transmission, two independent 64 kbit/s channels for use as B-channels (as defined in CCITT Recommendation I.412 [2]).

2.2 D-channel

This function provides, for each direction of transmission, one D-channel at a bit rate of 16 kbit/s, (as defined in CCITT Recommendation I.412 [2]).

2.3 Bit timing

This function provides bit (signal element) timing to enable the receiving equipment to recover information from the aggregate bit stream. Bit timing for the direction NT1 to LT shall be derived from the clock received by the NT1 from the LT.

2.4 Octet timing

This function provides 8 kHz octet timing for the B-channels. It shall be derived from the frame alignment.

2.5 Frame alignment

This function enables the NT1 and the LT to recover the time division multiplexed channels.

2.6 Activation from LT or NT1

This function restores the Digital Transmission System (DTS) between the LT and NT1 to its normal operational status. Procedures required to implement this function are described in Clause 6.

Activation from the LT could apply to the DTS only or to the DTS plus the customer equipment. In case the customer equipment is not connected, the DTS can still be activated (see NOTE in subclause 2.9).

2.7 Deactivation

This function is specified in order to permit the NT1 and the regenerator (if it exists) to be placed in a low power consumption mode or to reduce intrasystem crosstalk to other systems. The procedures and exchange of information are described in Clause 6. This deactivation should be initiated only by the exchange (ET).

2.8 Power feeding

This function provides for remote power feeding of one regenerator (if required), NT1 and restricted mode power feeding at the T reference point.

NOTE: The general power feeding strategy, given in Clause 8, may not be applicable for extremely long local lines. In such cases, specific power feeding methods (e.g. use of batteries in the NT1 or local power feeding of the NT1) may be applied. The specific methods are outside the scope of this ETR.

2.9 Operations and maintenance

This function provides the recommended actions and information described in ETR 001 [3].

The following categories of functions have been identified:

- maintenance command (e.g. loopback control in the regenerator or the NT1);
- maintenance information (e.g. line errors);
- indication of fault conditions;
- information regarding power feeding in NT1.

NOTE: The functions required for operations and maintenance of the NT1 and one regenerator (if required) and for some activation/deactivation procedures are combined in one transport capability to be transmitted along with the 2B+D channels. This transport capability is named the C_L channel.

3 Transmission medium

3.1 Description

The transmission medium over which the digital transmission system is expected to operate, is the local line distribution network.

A local line distribution network employs cables of pairs to provide services to customers.

In a local line distribution network, customers are connected to the local exchange via local lines.

A metallic local line is expected to be able to simultaneously carry bidirectional digital transmission providing ISDN basic rate access between LT and NT1.

To simplify the provision of ISDN basic access, a digital transmission system must be capable of satisfactory operation over the majority of metallic local lines without requirement of any special conditioning. Maximum penetration of metallic local lines is obtained by keeping ISDN requirements at a minimum.

In the following, the term Digital Local Line (DLL) is used to describe a metallic local line that meets minimum ISDN requirements.

3.2 Minimum ISDN requirements

- a) No loading coils.
- b) No open wires.
- c) When bridged taps (BTs) are present, the following rules apply:
 - maximum number of BTs: 2
 - maximum BT length: 500 m

NOTE: A BT is an unterminated twisted pair section bridged across the line.

3.3 DLL physical characteristics

In addition, to satisfying the minimum ISDN requirements, a DLL is constructed of one or more cable sections that are spliced or interconnected together.

The distribution or main cable is structured as follows:

- cascade of cable sections of different diameters and lengths;
- one or more BTs may exist at various points in feeder and distribution cables.

A general description is shown in figure 3 and typical examples of cable characteristics are given in table 1.

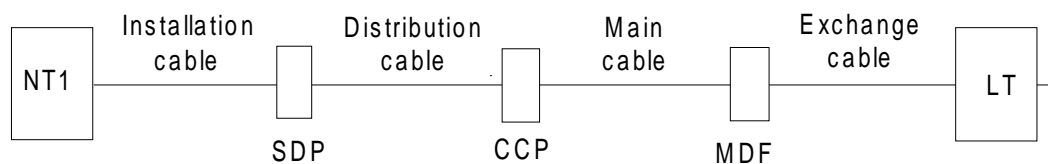

Points of interconnection:

- MDF: Main Distribution Frame
- CCP: Cross Connection Point (or splice)
- SDP: Subscriber Distribution Point

Figure 3: DLL physical model

Table 1: Cable characteristics

	exchange cable	main cable	distribution cable	installation cable
Wire diameter (mm)	0,5; 0,6 0,32; 0,4	0,3-1,4	0,3-1,4	0,4; 0,5; 0,6; 0,8; 0,9; 0,63
Structure	SQ or TP; L or B	SQ or TP;	L or B	SQ or TP or UP
Maximum number of pairs	1 200	2 400 (0,4 mm) 4 800 (0,3 mm)	600 (0,4 mm)	2 (aerial) 600 (in house)
Installation		underground in ducts	underground or aerial	aerial (drop) in ducts (in house)
Capacitance (nF/km at 800 Hz)	55 ... 120	25 ... 60	25 ... 60	35 ... 120
Wire insulation	PVC FRPE	paper; pulp paper; PE; cell. PE		PE, PVC
TP: Twisted Pairs PE: Polyethylene SQ: Star quads PVC: Polyvinylchloride UP: Untwisted pairs Pulp: Pulp of paper L: Layer Cell. PE: Cellular Foam Polyethylene B: Bundles (units) FRPE: Fire resistant PE				

3.4 DLL characteristics

The transmitted signal will suffer impairment due to crosstalk, impulsive noise and the non-linear variation with frequency of DLL characteristics.

3.4.1 Principal Characteristics

The principal electrical characteristics are:

- insertion loss (X), limited to 36 dB at 40 kHz for the system described in Annex A and to 32 dB at 40 kHz for the system described in Annex B;
- group delay, limited to 80 µs at 40 kHz;
- characteristic impedance, comprising real and negative imaginary parts, both of which vary non-linearly with frequency.

NOTE: The main reason for the difference of the value X for the two line systems are the following:

- the system defined in Annex B has a lower output power (peak voltage at output port), which provides lower signal to noise ratio against the adjusted noise level provided at the input port during performance tests.

3.4.2 Crosstalk

Crosstalk noise, in general, is due to finite coupling loss between pairs sharing the same cable, especially those pairs that are physically adjacent. Finite coupling loss between pairs causes a vestige of the signal flowing on one DLL (disturber DLL) to be coupled into an adjacent DLL (disturbed DLL). This vestige is known as crosstalk noise.

Near-End Crosstalk (NEXT) is assumed to be the dominant type of crosstalk.

Intrasystem NEXT or self NEXT results when all pairs interfering with each other in a cable carrying the same digital transmission system.

Intersystem NEXT results when pairs carrying different digital transmission systems interfere with each other. Definition of intersystem NEXT is not part of this ETR.

Intrasystem NEXT noise coupled into a disturbed DLL from a number of DLL disturbers is represented as being due to an equivalent single disturber DLL with a coupling loss versus frequency characteristic known as Power Sum Loss (PSL). Its value is 50 dB at 40 kHz and decreases by 15 dB/decade with frequency.

3.4.3 Unbalance about earth

The DLL will have finite balance about earth. Unbalance about earth is described in terms of Longitudinal Conversion Loss (LCL). Worst case value is 45,5 dB at 40 kHz decreasing with 5 dB/decade with frequency.

3.4.4 Impulse noise

The DLL will have impulse noise resulting from other systems sharing the same cables as well as from other sources. The design-requirement is an impulsive noise corresponding to figure 4.

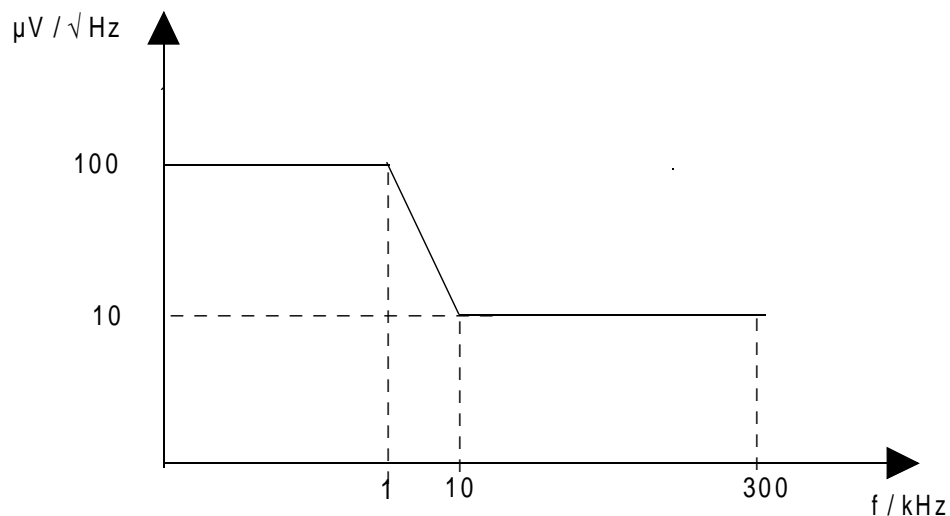

Figure 4: Impulse noise

3.4.5 Micro interruptions

The objective is that the digital transmission system should not deactivate or reset on occurrence of most micro-interruptions. The definition of a micro-interruption (line interruption) is for further study.

4 System performance

4.1 Performance requirements

Performance limits for the access digital section are specified in CCITT Recommendation G.821 [6]. The DTS performance must be such that these performance limits are met. For the purpose of conformance,

a DTS is required to meet the specific laboratory performance tests that are defined in the following subclauses.

The defined performance tests cover several aspects:

- the performance of the system, when activated, with several test loops and noise injected;
- to allow reduced test time where appropriate;
- the ability of the system to activate successfully even with a noise injected, which may result in a degraded performance when activated.

For the latter item the activation time may be greater than the limits defined in ETS 300 297 [8], for those tests where the expected error performance may be below 10^{-7} , but activated status shall be reached in all tests.

4.2 Performance measurements

Laboratory performance measurement of a particular digital transmission system requires the following preparations:

- a) definition of a number of DLL models to represent physical and electrical characteristics encountered in local line distribution networks;
- b) simulation of the electrical environment caused by impulsive noise and finite crosstalk coupling loss to other pairs in the same cable;
- c) specification of laboratory performance tests to verify that the performance limits referred to in subclause 4.1 will be met.

4.2.1 DLL physical models

Some representative models of DLLs (test loops) for evaluating the performance of transceivers for transmission systems are defined in figure 5.

NT(Customer)side

LT(Exchange)side

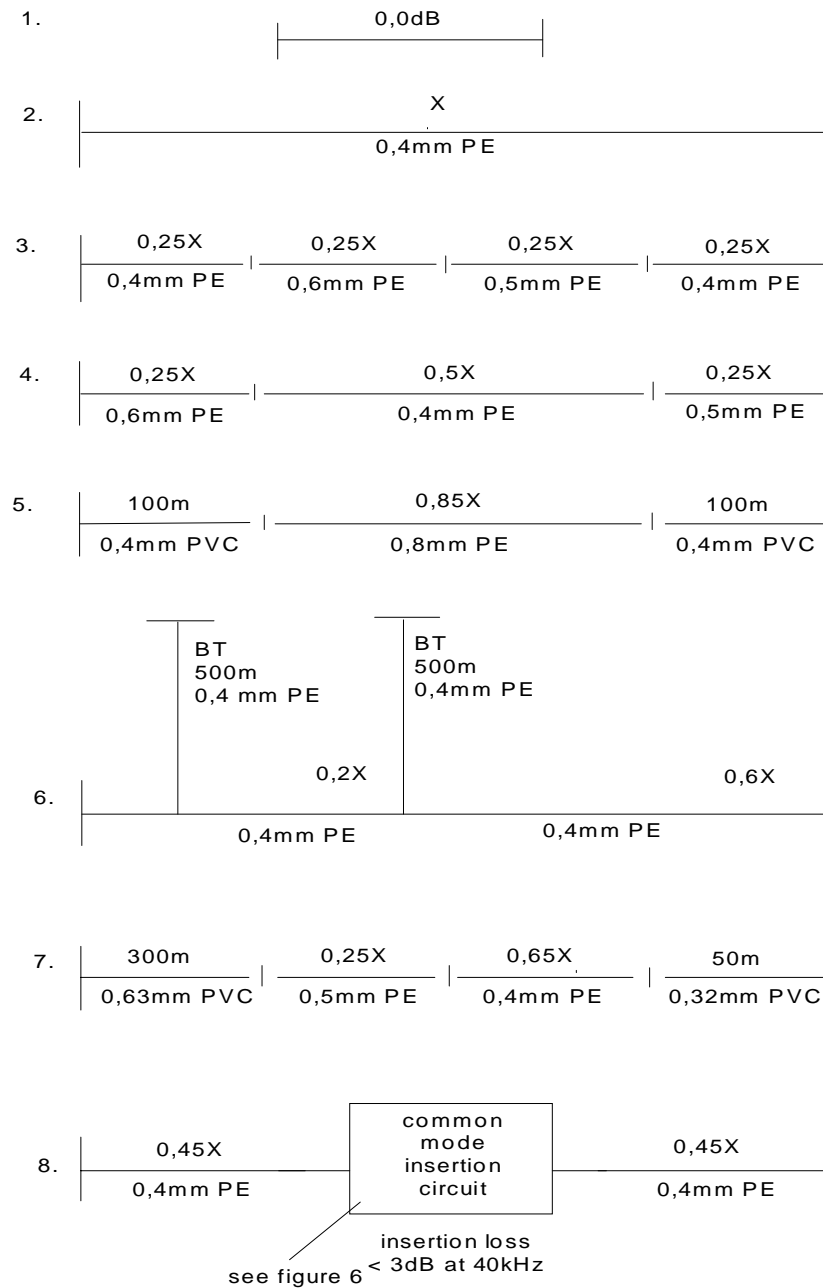

NOTE 1: The value of X (insertion loss) is 36 dB at 40 kHz for the system described in Annex A and 32 dB at 40 kHz for the system described in Annex B.

NOTE 2: Due to mismatches and BTs, the total DLL attenuation differs from the sum of the attenuation of the parts.

NOTE 3: Attenuation of separate sections is measured with 135 Ω termination.

Figure 5: DLL physical models for laboratory testing

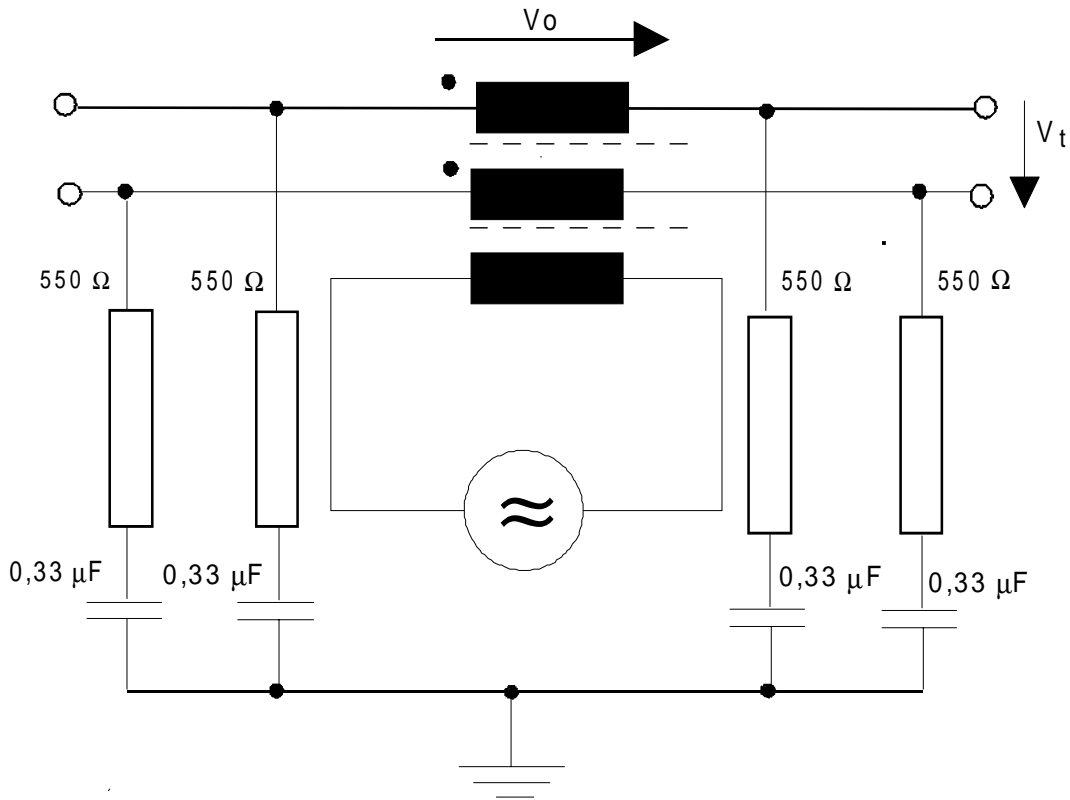

NOTE 1: The minimum return loss of the terminated circuit has to be equal to the minimum return loss of the system.

NOTE 2: The minimum longitudinal conversion loss V_o/V_t has to be 80 dB at 50 Hz decreasing with 20 dB/decade up to 1 kHz. By this, the transversal voltage is negligible against shaped noise.

Figure 6: Common mode insertion circuit for DLL No. 8

The basic parameters of the types of cable used in the test loops are given in table 2.

More detailed test cable characteristics are given in Annex C.

The test loops and artificial cable parameters include worst case examples as well as those more typical of a local network. They are chosen to provide the wide range of different echoes and distortions which may occur in European networks.

Table 2: Cable parameters at low frequencies (1 kHz and below)

Artificial cable type	C'(between wires)	R' (loop resistance) L'
0,32 mm PVC	120 nF/km	420 Ω/km 650μH/km
0,40 mm PVC	120 nF/km	270 Ω/km 650μH/km
0,40 mm PE	45 nF/km	270 Ω/km 680μH/km
0,50 mm PE	25 nF/km	172 Ω/km 680μH/km
0,60 mm PE	56 nF/km	120 Ω/km 700μH/km
0,63 mm PVC	120 nF/km	110 Ω/km 635μH/km
0,80 mm PE	38 nF/km	68 Ω/km 700μH/km

For abbreviations see table 1.

4.2.2 Intrasytem crosstalk

Crosstalk is dominated by impulsive noise.

4.2.3 Impulse noise modelling

4.2.3.1 Types of impulsive noise

Two classes of impulsive noise signals are used for testing:

- a) shaped noise.

The impulsive noise in local network lines as relevant for the digital transmission system, with power feeding provided over this line, can be best represented by flat white noise from 10 kHz to 300 kHz with a level of 10 $\mu\text{V}/\sqrt{\text{Hz}}$. The signal amplitude increases below 10 kHz with 20 dB per decade down to 1 kHz.

This shaped noise will be created by:

- 8192 defined amplitude-values, stored in a memory;
- read out with a clock rate of 1 320 720 Hz, resulting to a noise signal composed of 4 096 sinusoidal signals of $n \times 160$ Hz.

Spectral density:

Spectrum line n	Frequency range	Amplitude
1 - 6	0 - 1 kHz	U
7 - 62	1 - 10 kHz	Decrease with 20 dB/dec
63 - 1875	10 - 300 kHz	U/10
1876 - 4096	> 300 kHz	Zero

Phase relation for crestfactor 5:

$$\phi_n = (\Pi \times \text{INT} \frac{n^3 - n^2}{1,5 \times 4096}) \text{MOD} (2\Pi)$$

- b) a particular waveform, as represented in figure 7.

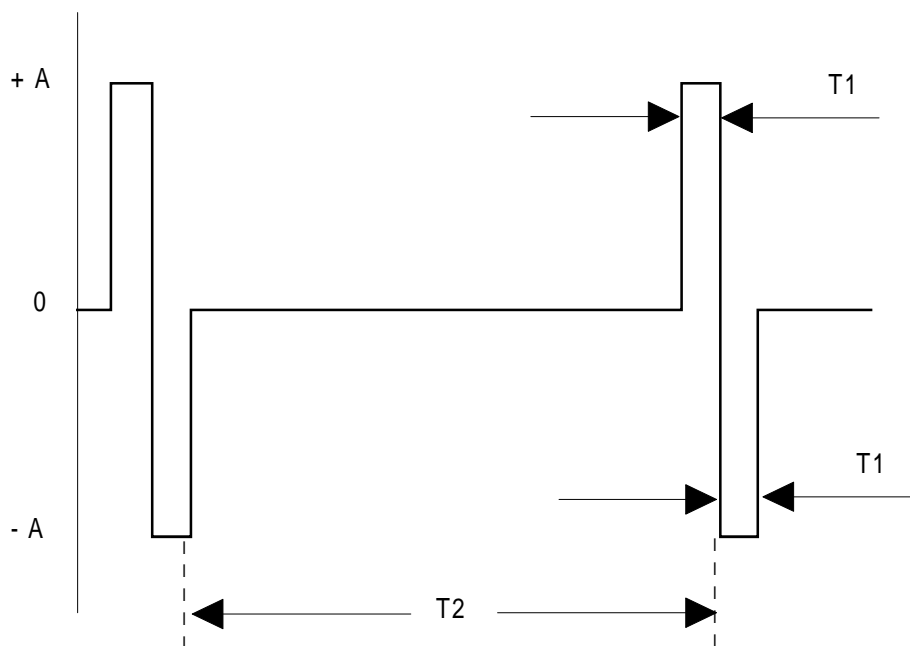

- A = peak level, set to 100 mV
- T1 = pulse width, set to 50 μ s
- T2 = period \gg T1, set to 500 ms

Figure 7: Waveform to simulate impulse noise

4.2.3.2 Measurement arrangement

Figure 8 shows the arrangement for testing with both impulse noise signals.

The coupling impedance shall be 4 kW \pm 10 % in the frequency range of 1 kHz to 300 kHz.

The signal is calibrated towards 67,5 W.

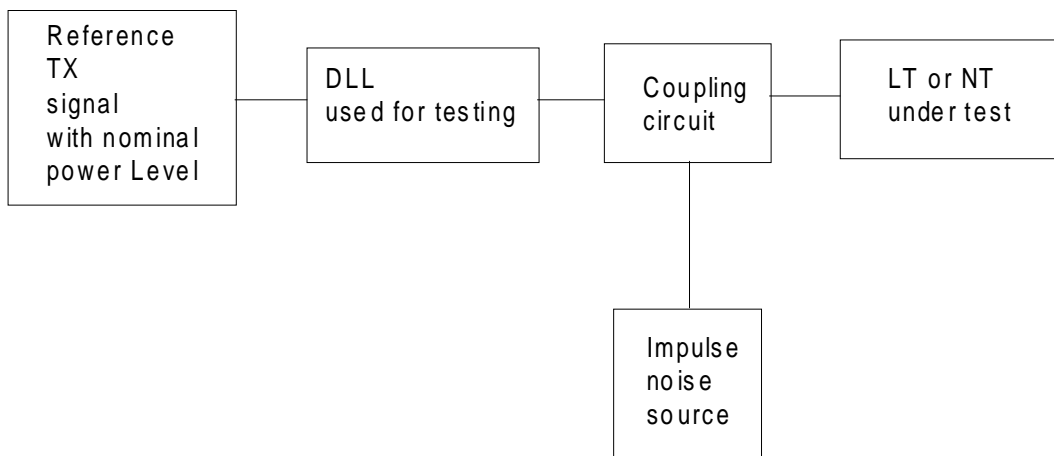

Figure 8: Impulse noise simulation and testing

4.2.4 Performance tests

All tests shall start from the deactivated status of the system.

TEST 1:

Test sequence

NOTE: The noise value is referenced to $10 \mu\text{V}/\sqrt{\text{Hz}}$ (= 0 dB) in the frequency range between 10 kHz and 300 kHz.

Test Loop	Noise	BER
a 2	+ 2,5 dB	$< 10^{-4}$
b 3	+ 2,5 dB	$< 10^{-4}$
c 3 reversed	+ 2,5 dB	$< 10^{-4}$
d 4	+ 2,5 dB	$< 10^{-4}$
e 4 reversed	+ 2,5 dB	$< 10^{-4}$
f 6	+ 2,5 dB	$< 10^{-4}$
g 6 reversed	+ 2,5 dB	$< 10^{-4}$
h 7	+ 2,5 dB	$< 10^{-4}$
i 7 reversed	+ 2,5 dB	$< 10^{-4}$
k loop of tests a...i with largest Bit Error Rate (BER)* with value X reduced by 10 dB	+ 10,5 dB	$< 10^{-4}$
l loop 1	+ 10,5 dB	$< 10^{-4}$
m 2 loops of tests a...kv with the largest BER*)	values of test a to k with the largest BER*) reduced by 2,5 dB and with jitter added as defined for the relevant system in Annex A or B	$< 10^{-7}$
n loop 5	0 dB	$< 10^{-7}$
o loop of tests m or n with the largest BER *) with value X increased by 4 dB	no noise	$< 10^{-8}$
p step loop 2 in steps of 200 m in the range from 200 m up to maximum loop length Measuring time for BER $< 10^{-7}$: 60 min Measuring time for BER $< 10^{-4}$: 30 s Measuring time for BER $< 10^{-8}$: 180 min, (another 180 min if failed)) If no errors are detected loop 3 shall be used for this test.	+ 2,5 dB	$< 10^{-4}$

Tests a...i (loop 2...7) are performed to find out the most critical loop for each implementation in a short time.

Test k and l are performed to test improvement of noise with reduced DLL-loss.

Test m and n is performed to test the most critical situation for BER $< 10^{-7}$ with nominal noise.

Test o is performed to test intrinsic noise of the implementation.

Test p is performed to test the ability of handling different loop-length.

TEST 2:

Test 2 shall use loop 2 and inserting the pulse signal given in figure 7 (representing noise peaks with high amplitudes) with the characteristics $T1 = 50 \mu s$, $T2 = 500 ms$, $A = 100 mV$, measurement time period $>10s$, $BER < 10^{-3}$.

TEST 3:

Test 3 shall test the common mode rejection capability of an implementation. Test loop 8 shall be used with a common mode triangle signal of 50 Hz with a voltage of 15 V rms for the first harmonic (25,5 Vp). The 21st harmonic (1 050 Hz) shall be 53 to 56 dB below the level of the first harmonic and the BER of the system shall be $<10^{-7}$.

4.3 Unbalance about earth

4.3.1 Longitudinal conversion loss

The longitudinal conversion loss (LCL, referring to CCITT Recommendation O.121 [7]) is given by:

$$LCL = 20 \log \frac{e_i}{e_m} \text{ dB}$$

where e_i is the applied longitudinal voltage referenced to the building ground; e_m is the resultant metallic voltage appearing across a 135 Ω resp 150 Ω termination, depending on the system as given in Annex A or Annex B.

The balance shall be as described in figure A.15 or figure B.7.

Figure 9 defines a measurement method for longitudinal conversion loss. For direct use of this test configuration, measurement should be performed with the NT1 powered up but inactive (no transmitted signal, i.e. driving 0 volts).

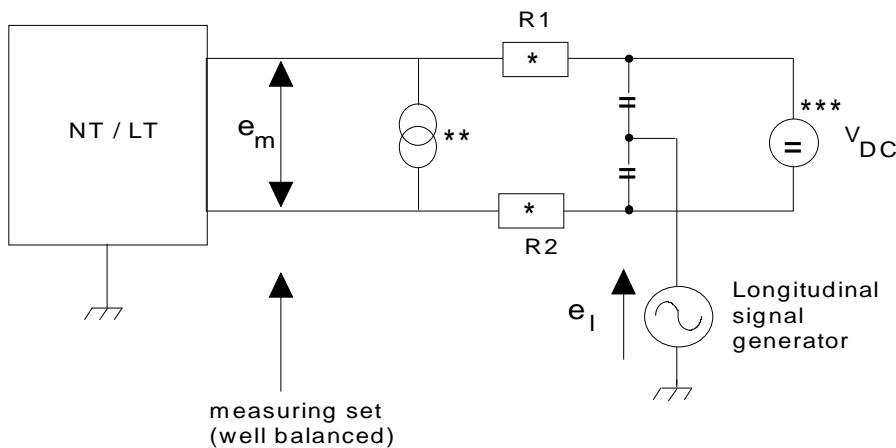

- * These resistors have to be matched: $R1 = R2 = RT/2$; $R1:R2 = 1 \pm 0,1 \%$.
- ** For LT-test only.

NOTE: During REG-Test each wire at the side which is not under test has to be connected to ground by a terminating impedance having the value of $RT/2$ in series with a capacitance of 0,33 μF .

RT: The nominal driving point impedance at the interface towards the NT1, REG and LT.

Values for RT for the relevant system are given in Annex A or Annex B. The characteristics of the power sink and source are dependant on the power feeding implementation.

Figure 9: Measurement method for longitudinal conversion loss

4.3.2 Longitudinal output voltage

The longitudinal component of the output signal shall have an rms voltage, in any 4 kHz equivalent bandwidth averaged in any 1 second period, < -50 dBV (provisional) over the frequency range 100 Hz to 150 kHz. Compliance with this limitation is required with a longitudinal termination having an impedance of 100 Ω in series with 0,15 μF nominal.

NOTE: For frequencies above 150 kHz the relevant EMC requirements will have to be taken into consideration (see subclause 9.4).

Figure 10 defines a measurement method for longitudinal output voltage. For direct use of this test configuration, the NT1 should be able to generate a signal in the absence of a signal from the LT and vice versa. The ground reference for these measurements shall be the building ground.

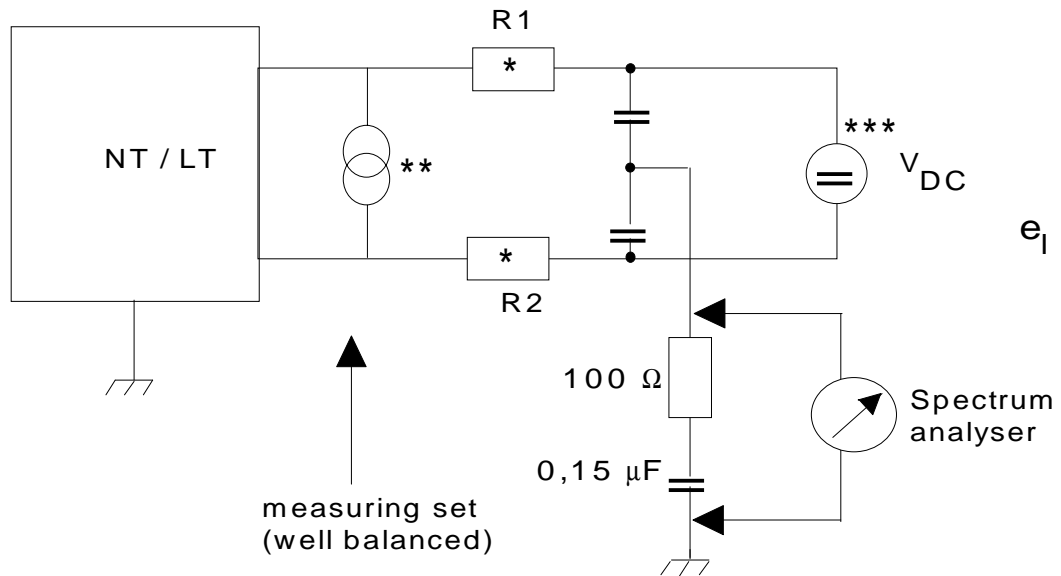

* These resistors have to be matched: $R1 = R2 = RT/2$; $R1:R2 = 1 \pm 0,1\%$

** For LT-test only.

*** For NT-test only.

NOTE: During REG-Test each wire at the side which is not under test has to be connected to ground by a terminating impedance having the value of $RT/2$ in series with a capacitance of 0,33 μF.

RT: The nominal driving point impedance at the interface towards the NT1, REG and LT.

Values for RT for the relevant system are given in Annex A or Annex B. The characteristics of the power sink and source are dependant on the power feeding implementation.

Figure 10: Measurement method for longitudinal output voltage

5 Transmission method

The transmission system provides for duplex transmission on 2-wire metallic local lines. Duplex transmission shall be achieved through the use of Echo Cancellation Hybrid (ECH). With the ECH method, illustrated in figure 11, the Echo Canceller (EC) produces a replica of the echo of the transmitted signal that is subtracted from the total received signal. The echo is the result of imperfect balance of the hybrid and impedance discontinuities in the line.

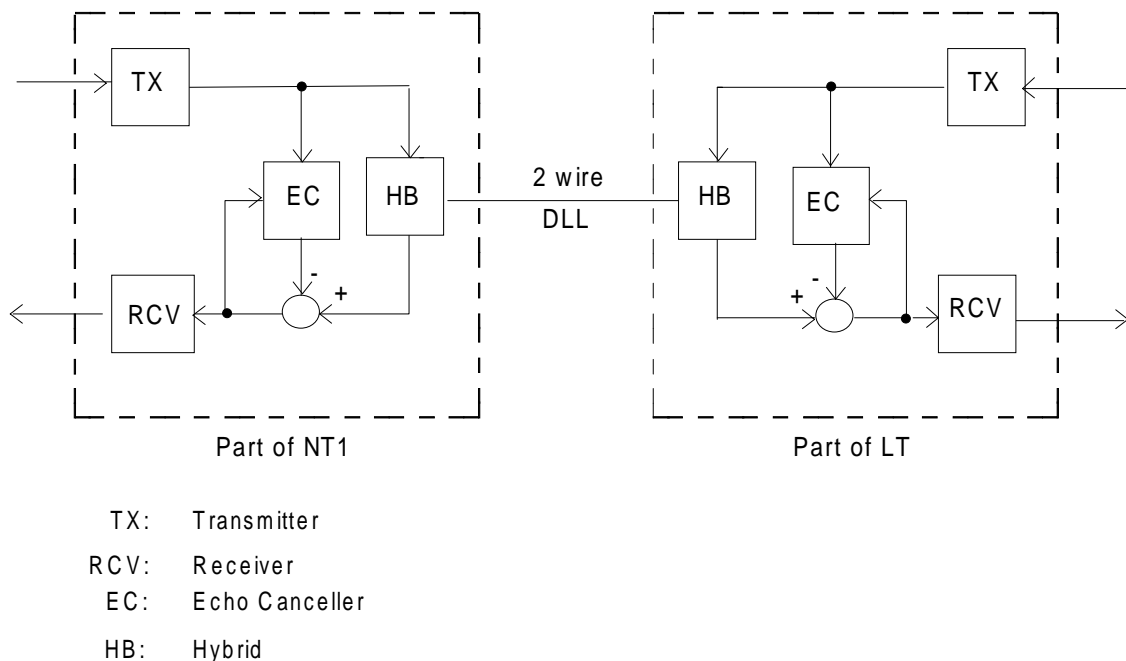

Figure 11: ECH method functional diagram

6 Activation/deactivation

6.1 General

The functional capabilities of the activation/deactivation procedure are specified in ETS 300 297 [8] and the transmission system has to meet the requirements specified therein. In particular, it has to make provision to convey the signals defined in ETS 300 297 [8], which are required for the support of the procedures.

6.2 Physical representation of signals

The signals used on the digital transmission system are system dependent and can be found in Annexes A and B.

7 Operation and maintenance

7.1 Operation and maintenance functions

The functions are defined in ETS 300 297 [8].

7.2 **C_L channel**

7.2.1 **C_L channel definition**

This channel is conveyed by the digital transmission system in both directions between LT and NT1 via a possible regenerator. It is used to transfer information concerning operation, maintenance and activation/deactivation of the digital transmission system and of the access digital section.

Even though some of these functions have an optional status, the C_L channel shall have the capability to convey the necessary information to perform the function.

7.2.2 **C_L channel requirements**

The functions to be supported by the C_L channel are given in Annex A and Annex B.

7.3 **Metallic loop testing**

The requirements for NT1 and REG regarding metallic loop testing are described in subclause 8.8.

8 **Power feeding**

8.1 **General**

This Clause deals with power feeding of the NT1, one regenerator (if required) and the provision of power to the User Network Interface (UNI) according to ETS 300 297 [8] under normal and restricted conditions.

When activation/deactivation procedures are applied, power down modes at the NT1, regenerator (if required) and the LT are defined.

8.2 **Power feeding functions**

For power feeding three functions can be distinguished:

- power feeding of the REG;
- power feeding of the NT1;
- power feeding of the user network interface.

8.2.1 **Power feeding of the REG**

Remote power feeding of the REG from the network is preferred.

8.2.2 **Power feeding of the NT1**

Remote powering of the NT1 from the network is preferred under all conditions.

NOTE: The general power feeding strategy may not be applicable for extremely long local lines. In those cases specific power feeding methods (e.g. use of batteries in the NT1 or local power feeding of the NT1) may be applied. Those specific methods are outside the scope of this ETR.

8.2.3 **Power feeding of the user network interface**

Power feeding of the UNI is described in ETS 300 012 [9].

According to ETS 300 012 [9], power feeding of restricted mode power to the UNI from the network during restricted mode conditions has to be considered.

The provision of restricted mode power is not related to the state of the NT1 (e.g. activated or deactivated).

8.3 DLL resistance

This parameter is a particular subject of the individual local network and, therefore, out of the scope of this ETR. Its maximum value depends on the LT output voltage, the power consumption of the NT1 and regenerator (if required) and the power feeding arrangement of the user network interface.

8.4 Wetting current

The feeding current to the NT1 and regenerator (if required) results in a Direct Current (DC) through the DLL. This feeding current is enough to fulfill the wetting current requirements.

8.5 LT aspects

8.5.1 Safety

For safety requirements, EN 41003 [17] shall be applied.

8.5.2 Feeding voltage from the LT

No unique remote power feeding voltage to be provided by the LT can be defined because of the following reasons:

- different national safety requirements;
- different DLL planning rules;
- the optional use of regenerators.

A number of feeding voltage ranges is defined for different applications.

The minimum and maximum voltages from those ranges at the output of the LT are as follows:

Range	Minimum (V)	Maximum (V) ¹
1	51	69
2	66	70
3	91	99
4	90	110
5	105	115

The dynamic power feeding requirements for each voltage range are for further study.

8.6 Power requirements of NT1 and regenerator

8.6.1 Power requirements of NT1

- a) Active state without powering of user- network interface or when normal mode power is supplied to the network: ≤ 500 mW.
- b) Active state including restricted mode powering of the user-network interface as defined in ETS 300 012 [9]: ≤ 1100 mW. This value includes a possible overload or short circuit condition at the user-network interface.
- c) Deactivated state without powering of the UNI or when normal power is supplied: ≤ 120 mW.

NOTE 1: For a period until the end of 1994, NTs which can not meet these requirements may consume ≤ 650 mW for state a) and $\leq 1\ 300$ mW for state b), subject to the provision of that power by the LT.

NOTE 2: In case of a NT1 with optional maintenance functions, the power consumption could be increased.

8.6.2 Power requirement of regenerator

- a) Active state: $\leq 1\ 000$ mW.
- b) Deactivated state: ≤ 180 mW.

NOTE: For case a), the target value of 750 mW should be reached in the long term.

8.6.3 Feeding voltage to the NT1

The minimum voltage at which the NT1 should work is 28 V.

Considering that the minimum voltage at the NT1 is depending on the remote powering voltage as well as the power consumption of the NT1 and REG, this voltage could be increased accordingly.

8.6.4 Voltage drop across the REG

The voltage drop between the LT-side and the NT-side of the REG shall be less than 2V under all normal operation conditions.

8.7 Current transient limitation

The rate of change of current drawn by the NT1 or regenerator from the network shall not exceed 1 mA/ μ s.

This is applicable only when initial powering of the NT1 has been completed.

8.8 DC and low frequency AC termination of NT1 and REG

Within 1 second after removing the remote power, the NT1 shall enter a high impedance state. This state shall be maintained as long as the voltage on the line stays below 18 V (DC + Alternating Current (AC) peak). In this state the leakage current shall be less than 10 μ A and the capacitance shall be greater than 1 μ F.

The requirements for the REG are for further study.

9 Environmental conditions

9.1 Climatic conditions

Climatograms applicable to the operation of NT1 and LT equipment in weather protected and non-weather protected locations can be found in ETS 300 019 [15]. The choice of classes is under national responsibility.

9.2 Safety

Isolation is required in the NT1 (see also ETR 012 [16]):

- at least basic insulation (see NOTE) between line and interface at T reference point according to EN 41003 [17] and EN 60950 [18];
- mains and interface at T reference point according to ETS 300 047-4 [13];
- mains and line according to EN 41003 [17] based on the safety class allocated as Telecommunication Network Voltage (TNV) circuit; this includes isolation between line and any earth connection.

NOTE: If under single fault condition the feeding voltage on the line and the feeding voltage on the user-network interface can sum to a value greater than 120 V DC then double insulation may be required.

9.3 Overvoltage protection

For LT: Conform to CCITT Recommendation K.12 [10] and K.20 [11].

For NT1: Conform to CCITT Recommendation K.21 [12] and ETS 300 047-5 [13].

Fro REG: Conform to CCITT Recommendation K.17 [19].

9.4 EMC

For LT: National regulations are to be applied until the ETS, which is under development on EMC requirements for network equipment is available.

For NT1: prEN 50096 [14] shall be used for the interface at T reference point and may also be taken as the basis for the line side.

Annex A: Definition of a system using 2B1Q line code

A.1 Line code

The line code shall be 2 Binary, 1 Quaternary (2B1Q). This is a 4-level code and is used without redundancy.

The bit stream entering the NT1 from the interface at reference point T (or entering the LT from the ET) shall be grouped into pairs of bits for conversion to quaternary symbols that are called **quats**. Figure A.1 shows the relationship of the bits in the B and D channels to quats. The B-channel and D-channel bits are scrambled before coding. M_1 through M_6 bits of the C_L channel are also paired, coded and scrambled in the same way.

Each successive pair of scrambled bits in the binary data stream is converted to a quaternary symbol to be output from the transmitters, as specified below:

First Bit (Sign)	Second Bit (Magnitude)	Quaternary Symbol (Quat)
1	0	+3
1	1	+1
0	1	-1
0	0	-3

At the receiver, each quaternary symbol is converted to a pair of bits by reversing the table above, descrambled, and formed into a bit stream representing B and D channels and a CL channel containing M bits for maintenance and other purposes. The bits in the B and D channels are properly placed by reversing the relationship in figure A.1.

A.2 Line baud rate

The line symbol rate is 80 kband.

A.2.1 NT1 clock tolerance

The tolerance of the free running NT1 clock is ± 100 ppm.

A.2.2 LT clock tolerance

The tolerance of the clock provided at the LT is ± 5 ppm.

A.2.3 REG clock tolerance

The tolerance of the free running REG clock is ± 100 ppm.

A.3 Frame structure

A frame shall be 120 quaternary symbols transmitted within a nominally 1,5 ms interval. Each frame contains a frame word, 2B+D data and C_L channel bits shown in figure A.2.

A.3.1 Frame length

The number of 2B+D slots in a frame is 12. Each slot contains 18 bits.

A.3.2 Bit allocation in direction LT to NT1

The bit allocation of the frames are shown in figures A.1 and A.2.

A.3.3 Bit allocation in direction NT1 to LT

The bit allocation of the frames are shown in figures A.1 and A.2.

Data	Time ---->								
	B ₁				B ₂				D
Bit pairs	b ₁₁ b ₁₂	b ₁₃ b ₁₄	b ₁₅ b ₁₆	b ₁₇ b ₁₈	b ₂₁ b ₂₂	b ₂₃ b ₂₄	b ₂₅ b ₂₆	b ₂₇ b ₂₈	d ₁ d ₂
Quat # (relative)	q ₁	q ₂	q ₃	q ₄	q ₅	q ₆	q ₇	q ₈	q ₉
# Bits	8				8				2
# Quats	4				4				1

Where: b₁₁ = first bit of B₁ octet as received at reference point T;
 b₁₈ = last bit of B₁ octet as received at reference point T;
 b₂₁ = first bit of B₂ octet as received at reference point T;
 b₂₈ = last bit of B₂ octet as received at reference point T;
 d₁d₂ = consecutive D-channel bits
 (d₁ is first bit of pair as received at reference point T);
 q_i = ith quat relative to start of given 18-bit 2B+D data field.

NOTE: There are 12 2B+D 18-bit fields per 1,5 ms basic frame.

Figure A.1: 2B1Q encoding of 2B+D bit fields

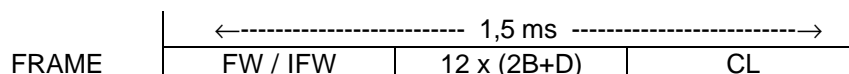

Function	Frame word	2B+D	Overhead
# Quats	9	108	3
Quat Positions	1-9	10-117	118-120
# Bits	18	216	6
Bit Positions	1-18	19-234	235-240

NOTE: Frames in the NT1 to network direction are offset from frames in the network to NT1 direction by 60 ± 2 quats.

Symbols and abbreviations:

- quat = quaternary symbol = 1 baud.
- 3, -1, +1, +3 = symbol names.
- 2B+D = Customer data channels B₁, B₂ and D.
- FW = Frame Word (9 symbol code).
- = +3 +3 -3 -3 -3 +3 -3 +3 +3
- IFW = Inverted (or complementary) Frame Word.
- = -3 -3 +3 +3 +3 -3 +3 -3 -3
- CL = M-channel bits, M₁-M₆.

Figure A.2: Frame structure of 2B1Q transmission system

A.4 Frame word

The Frame Word (FW) is used to allocate bit positions to the B, D, and C_L channels. It may also be used for baud synchronization.

A.4.1 Frame word in direction LT to NT1

The code for the FW in all frames except the first in a multiframe shall be:

$$FW = +3 +3 -3 -3 -3 +3 -3 +3 +3$$

The code for the FW of the first frame of a multiframe shall be an Inverted Frame Word (IFW):

$$IFW = -3 -3 +3 +3 +3 -3 +3 -3 -3$$

A.4.2 Frame word in direction NT1 to LT

See subclause A.4.1.

A.5 Frame alignment procedure

Unique frame alignment procedure is not specified. However, the time limits specified in Clause A.10 shall be met.

A.6 Multiframe

To enable the allocation of the C_L channel bits over more than one frame, a multiframe is used. The start of the multiframe is determined by the IFW. The number of frames in a multiframe is 8.

A.6.1 Multiframe word in direction NT1 to LT

See subclause A.4.1.

A.6.2 Multiframe word in direction LT to NT1

See subclause A.4.1.

A.7 Frame offset between LT to NT1 and NT1 to LT frames

The NT1 shall synchronize transmitted frames with received frames (LT to NT1 direction). Transmitted frames shall be offset with respect to received frames by 60 ± 2 quaternary symbols (i.e. approximately 0,75 ms).

A.8 C_L channel

The C_L channel consists of the last three symbols (6 bits) in each basic frame of the multiframe.

A.8.1 Bit rate

The bit rate for the C_L channel is 4 kbit/s.

A.8.2 Structure

48 bits of a multiframe are used for the CL channel and are referred to as M bits.

24 bits per multiframe (2 kbit/s) are allocated to an embedded operations channel (EOC) which supports operations communications needs between the network and the NT1.

12 bits per multiframe (1 kbit/s) are allocated to a Cyclic Redundancy Check (CRC) function.

12 bits per multiframe (1 kbit/s) are allocated to other functions and spare bits as shown in figure A.3.

A.8.3 Protocol and procedures

The C_L channel functions (M bits) specified below are based on the bit allocation for the multiframe defined in figure A.3.

		FRAMING	2B+D	CL (overhead) bits $M_1 - M_6$					
Quat positions		1-9	10-117	118s	118m	119s	119m	120s	120m
Bit positions		1-18	19-234	235	236	237	238	239	240
Multi frame #	Basic frame #	Frame word	2B+D	M_1	M_2	M_3	M_4	M_5	M_6
LT to NT1									
A	1	IFW	2B+D	EOC _{a1}	EOC _{a2}	EOC _{a3}	ACT	1	1
	2	FW	2B+D	EOC _{dm}	EOC _{i1}	EOC _{i2}	DEA	1	FEBE
	3	FW	2B+D	EOC _{i3}	EOC _{i4}	EOC _{i5}	1	CRC ₁	CRC ₂
	4	FW	2B+D	EOC _{i6}	EOC _{i7}	EOC _{i8}	1	CRC ₃	CRC ₄
	5	FW	2B+D	EOC _{a1}	EOC _{a2}	EOC _{a3}	1	CRC ₅	CRC ₆
	6	FW	2B+D	EOC _{dm}	EOC _{i1}	EOC _{i2}	1	CRC ₇	CRC ₈
	7	FW	2B+D	EOC _{i3}	EOC _{i4}	EOC _{i5}	UOA	CRC ₉	CRC ₁₀
	8	FW	2B+D	EOC _{i6}	EOC _{i7}	EOC _{i8}	AIB	CRC ₁₁	CRC ₁₂
NT1 to LT									
1	1	IFW	2B+D	EOC _{a2}	EOC _{a2}	EOC _{a3}	ACT	1	1
	2	FW	2B+D	EOC _{dm}	EOC _{i1}	EOC _{i2}	PS ₁	1	FEBE
	3	FW	2B+D	EOC _{i3}	EOC _{i4}	EOC _{i5}	PS ₂	CRC ₁	CRC ₂
	4	FW	2B+D	EOC _{i6}	EOC _{i7}	EOC _{i8}	NTM	CRC ₃	CRC ₄
	5	FW	2B+D	EOC _{a1}	EOC _{a2}	EOC _{a3}	CSO	CRC ₅	CRC ₆
	6	FW	2B+D	EOC _{dm}	EOC _{i1}	EOC _{i2}	1	CRC ₇	CRC ₈
	7	FW	2B+D	EOC _{i3}	EOC _{i4}	EOC _{i5}	SAI	CRC ₉	CRC ₁₀
	8	FW	2B+D	EOC _{i6}	EOC _{i7}	EOC _{i8}	1*	CRC ₁₁	CRC ₁₂
2,3, ...									

NOTE: 8 x 1,5 ms basic frames --> 12 ms multiframe.
 NT1 to network multiframe delay offset from network to NT1 multiframe by 60 ± 2 quats (approximately 0,75 ms).
 All bits other than the FW are scrambled.

Figure A.3: 2B1Q multiframe technique and overhead bit assignments

Symbols and abbreviations to figure A.3:	
ACT =	activation bit (set to ONE during activation).
AIB =	alarm indication bit (ZERO indicates interruption).
CRC =	Cyclic Redundancy Check: covers 2B+D & M4: 1 = most significant bit; 2 = next most significant bit, etc.
CSO =	Cold-start-only bit (ONE indicates cold-start-only).
DEA =	deactivation bit (set to ZERO to announce deactivation).
EOC =	embedded operations channel: a = address bit; dm = data/message indicator; i = information (data/message).
FEBE =	far end block error bit (ZERO for errored multiframe).
NMT =	NT1 in test mode bit (ZERO indicates test mode).
PS ₁ , PS ₂ =	power status bits (ZERO indicates power problems).
quat =	pair of bits forming quaternary symbol: s = sign bit (first) in quat; m = magnitude bit (second) in quat.
SAI =	S-activation indicator bit (optional, set=1 for S/T activity).
UOA =	DLL-only-bit (optional, set=1 to activate S/T).
"1" =	reserve bit for future definition; set=ONE
"1*" =	network indicator bit; reserved for network use, set=ONE.
2B+D =	user data, bits 19-234 in basic frame.
M =	CL channel, bits 235-240 in basic frame.
FW/IFW =	frame word/inverted frame word, bits 1-18 in frame.

A.8.3.1 Error monitoring function

A.8.3.1.1 Cyclic redundancy check

The CRC bits are the M₅ and M₆ bits in frames 3 through 8 of the multiframe. The CRC is an error detection code that shall be generated from the appropriate bits in the multiframe and inserted into the bit stream by the transmitter. At the receiver, a CRC calculated from the same bits shall be compared with the CRC value received in the bit stream. If the two CRCs differ, there has been at least one error in the covered bits in the multiframe.

A.8.3.1.2 CRC algorithms

The CRC code shall be computed using the polynomial:

$$P(x) = x^{12} \oplus x^{11} \oplus x^3 \oplus x^2 \oplus x \oplus 1$$

where

$$\oplus = \text{modulo 2 summation.}$$

One method of generating the CRC code for a given multiframe is illustrated in figure A.4. At the beginning of a multiframe all register cells are cleared. The multiframe bits to be covered by the CRC are then clocked into the generator from the left. During bits which are not covered by the CRC (FW, IFW, M₁, M₂, M₃, M₅, M₆) the state of the CRC generator is frozen and no change in state of any of the stages takes place. After the last multiframe bit to be covered by the CRC is clocked into REGISTER CELL 1, the 12 register cells contain the CRC code of the next multiframe. Between this point and the beginning of the next multiframe, the register cell contents are stored for transmission in the CRC field of the next multiframe. Notice that multiframe bit CRC1 resides in REGISTER CELL 12, CRC2 in REGISTER CELL 11, etc.

NOTE: The ONEs and ZEROs from the interface at the T reference point, and corresponding bits from the network (across the V₁ reference point), must be treated as ONEs and ZEROs, respectively, for the computation of the CRC.

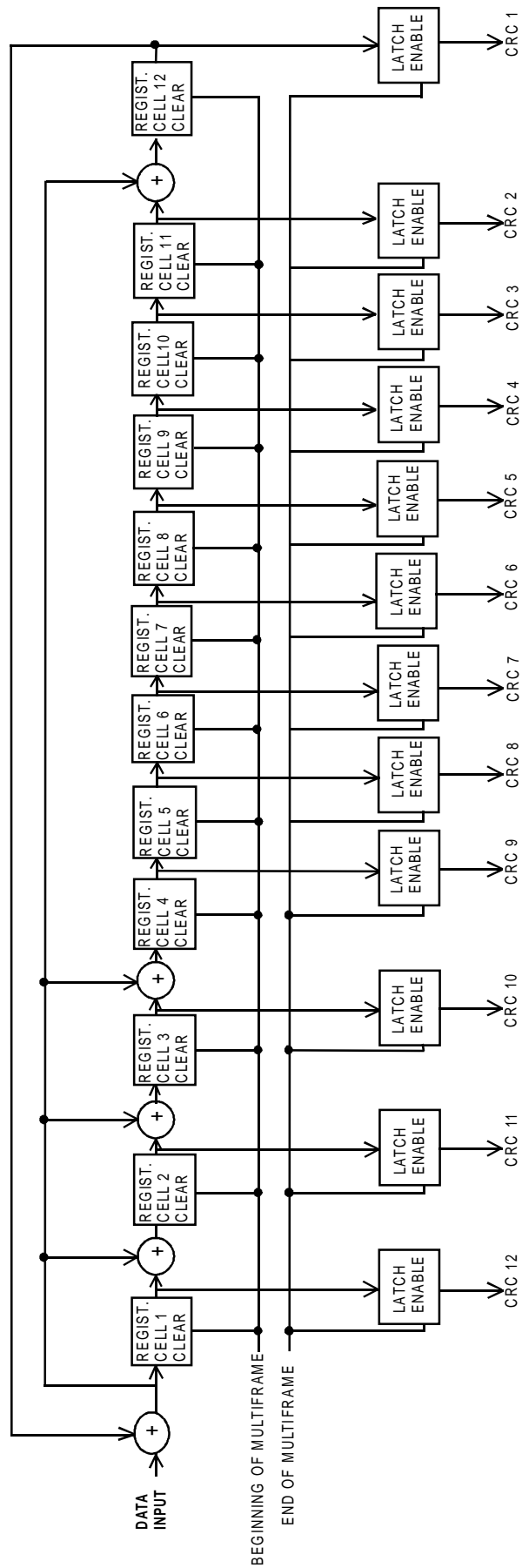

Figure A.4: CRC-12 generator

A.8.3.1.3 Bits covered by the CRC

The CRC bits shall be calculated from the bits in the D-channel, both B-channels, and the M_4 bits.

A.8.3.2 Other C_L channel functions

A number of transceiver operations and maintenance functions are handled by M_4 , M_5 , and M_6 bits in the multiframe. These bits are defined in subclauses A.8.3.2.1 to A.8.3.2. To reflect a change in status, a new value for M_4 bits shall be repeated in at least three consecutively transmitted multiframe.

A.8.3.2.1 Far end block error bit, mandatory

The Far End Block Error (FEBE) bits shall be the M_6 bits in the second basic frame of the multiframe transmitted by either transceiver. The FEBE bit shall be set to ONE if there are no CRC errors in the multiframe and ZERO if the multiframe contains a CRC error. The FEBE bit shall be placed in the next available outgoing multiframe and transmitted back to the originator. The FEBE bits may be monitored to determine the performance of the far end receiver.

A.8.3.2.2 The ACT bit, mandatory

The ACT bit is the M_4 bit in the first frame of multiframe transmitted by either transceiver. The ACT bit is used as a part of the start-up sequence to communicate readiness for layer 2 communication progress (see subclause A.10.1.5.2). If a loopback 2B+D is requested, the ACT Bit is set to ONE as a part of the loopback start-up sequence to communicate readiness to loopback data.

A.8.3.2.3 The DEA bit, mandatory

The DEA bit is the M_4 bit in the second frame of multiframe transmitted from the LT (see Clause A.3 and figure A.3). The DEA bit is used by the LT to communicate to the NT1 its intention to deactivate (see subclause A.10.1.5.2).

A.8.3.2.4 NT1 power status bits

The M_4 bits in the second and third basic frames of multiframe transmitted by the NT1 (see figure A.3) are reserved for NT1 power status indication; their use is optional. When not used, these bits shall be set to ONE in SN3. See Appendix I.

A.8.3.2.5 NT1 Test Mode (NTM) indicator bit

The M_4 bit in the fourth basic frame of multiframe transmitted by the NT1 to the network (see figure A.3) is reserved for NT1 test mode indication. This function is not used, the bit shall be set to ONE in SN3. See Appendix I.

A.8.3.2.6 Cold-Start-Only (CSO) bit

The M_4 bit in the fifth frame of the multiframe transmitted by an NT1 is reserved for cold-start-only indication. This function is not used, this bit shall be set to ZERO in SN3. See Appendix I.

A.8.3.2.7 DLL-Only-Activation (UOA) bit

The M_4 bit in the seventh basic frame of the multiframe transmitted by an LT is reserved for DLL-only-activation; its use is optional. If this function is not used, this bit shall be set to ONE in SL2 and SL3. See Appendix I.

A.8.3.2.8 S/T-Interface-Activity-Indicator (SAI) bit

The M_4 bit in the seventh basic frame of the multiframe transmitted by an NT1 is reserved for S/T-interface-activity-indication; its use is optional. If this function is not used, this bit shall be set to ONE in SN3. See Appendix I.

A.8.3.2.9 Alarm Indicator Bit (AIB)

The M_4 bit in the eighth basic frame of the multiframes transmitted by the network towards the NT1 is reserved for the AIB. This function is not used, the AIB bit shall be set to ONE in SN3. See Appendix I.

A.8.3.2.10 Network Indicator Bit (NIB) for network use

The NIB bit shall be the M_4 bit in the eighth basic frame of multiframes transmitted by the NT1 toward the network. This function is not used, the NT1 shall always set this bit to ONE in SN3.

A.8.3.2.11 Reserved bits

All bits in M_4 , M_5 , and M_6 not otherwise assigned are reserved for future standardisation. Reserved bits shall be set to ONE before scrambling.

A.8.3.3 Embedded Operations Channel (EOC) functions

Twenty-four bits per multiframe (2 kbit/s) are allocated to an EOC which supports operations communications needs between the network and the NT1.

A.8.3.3.1 EOC frame

The EOC frame shall be composed of 12 bits synchronized to the multiframe (see table A.1).

Table A.1: The EOC frame layout

Bits	3	1	8
Function provided	Address field	Data/message indicator	Info field

The three-bit address field may be used to address up to 7 locations. Only the specification of addresses of messages for the NT1 are within the scope of this ETR. The additional addresses are for intermediate network elements where the system is used to extend access involving REG's and, e.g., carrier systems.

The detailed coding for the address of REGs or other intermediate elements can be found in Appendix II.

The data/message indicator bit shall be set to ONE to indicate that the information field contains an operations message; it shall be set to ZERO to indicate that the information field contains numerical data. Up to 256 messages may be encoded in the information field.

Exactly two EOC frames shall be transmitted per multiframe consisting of all M_1 , M_2 , and M_3 bits (see figure A.3).

A.8.3.3.2 Mode of operation

The EOC protocol operates in a repetitive command/response mode. Three identical properly-addressed consecutive messages shall be received before an action is initiated. Only one message, under the control of the network, shall be outstanding (not yet acknowledged) on a complete basic access EOC at any one time.

The network shall continuously send an appropriately addressed message. In order to cause the desired action in the addressed element, the network shall continue to send the message until it receives three identical consecutive EOC frames from the addressed device that agree with the transmitted EOC frame. When the network is trying to activate an EOC function, autonomous messages from the NT1 will interfere with confirmation of receipt of a valid EOC message. The sending by the NT1 and receipt by the network of three identical consecutive properly addressed "Unable to Comply" messages constitutes notification to the network that the NT1 does not support the requested function, at which time the network may abandon its attempt.

The addressed element shall initiate action when, and only when, three identical, consecutive, and properly addressed EOC frames, that contain a message recognised by the addressed element, have been received. The NT1 shall respond to all received messages. The response should be an echo of the received EOC frame towards the network with two exceptions described below. Any reply or echoed EOC frame shall be transmitted in the next available returning EOC frame, which allows a processing delay of approximately 2,25 ms.

If the NT1 does not recognise the message (data/message bit set to ONE) in a properly addressed EOC frame, rather than echo, on the third and all subsequent receipts of that same correctly addressed EOC frame it shall return the "Unable to Comply" message in the next available EOC frame.

If the NT1 receives EOC frames with addresses other than its own address (000), or the broadcast address (111), it shall, in the next available EOC frame, return an EOC frame toward the network containing the "Hold State" message and its own address (the NT1 address, 000).

If a NT1, not implementing EOC data transfer functions, receives a data byte (data/message bit set to ZERO) in a properly addressed EOC frame, rather than echo on the third and subsequent receipts of that same correctly addressed EOC frame it shall return the "Unable to Comply" message in the next available EOC frame.

The protocol specification has made no provision for autonomous messages from the NT1.

All actions to be initiated at the NT1 shall be latching, permitting multiple EOC-initiated actions to be in effect simultaneously. A separate message shall be transmitted by the network to unlatch.

A.8.3.3.3 Addressing

An NT1 shall recognise either of two addresses, an NT1 and a broadcast address. These addresses are as follows:

Node	Address
NT1	000
Broadcast (all nodes)	111

A NT1 shall use the address 000 in sending the "Unable to Comply" message.

A REG or other intermediate elements shall use the address bit field values 1 to 6, see subclause A.8.3.3.1.

A.8.3.3.4 Definition of required EOC functions

- 1) Operate 2B+D Loopback: This function directs the NT1 or REG to loopback the user-data (2B+D) bit stream toward the network. This loopback is transparent (see ETS 300 297 [8]).
- 2) Operate B1-channel (or B2-channel) Loopback: This function directs the NT1 or REG to loopback an individual B channel toward the network. The individual B-channel loopback can provide per-channel maintenance capabilities without totally disrupting service to the customer. This loopback is transparent (see ETS 300 297 [8]). The implementation and operation of the individual B-channel loopbacks is optional.
- 3) Return to Normal: The purpose of this message is to release all outstanding EOC-controlled operations and to reset the EOC processor to its initial state.
- 4) Unable to Comply Acknowledgement: This will be the confirmation that the NT1 or REG has validated the receipt of an EOC message, but that the EOC message is not in the menu of the NT1.
- 5) Request Corrupt CRC: This message requests the sending of corrupt CRCs toward the network, until canceled with Return to Normal.
- 6) Notify of Corrupted CRC: This message notifies the NT1 and/or REG that intentionally corrupted CRCs will be sent from the network until cancellation is indicated by Return to Normal.
- 7) Hold State: This message is sent by the network to maintain the NT1 EOC processor and any active EOC controlled operations in their present state. This message may also be sent by the NT1 toward the network to indicate that the NT1 has received an EOC frame with an improper address.

A.8.3.3.5 Codes for required EOC functions

Table A.2 shows the codes for each of the EOC functions defined in subclause A.8.3.3.4 above.

Table A.2 Messages required for command/response EOC mode

Origin (o) & Destination (d) & Transfer (t)				
MESSAGE	Message code	Network	NT1	REG
Operate 2B+D Loopback	0101 0000	o	d	t/d
Operate B1-channel Loopback *	0101 0001	o	d	t/d
Operate B2-channel Loopback *	0101 0010	o	d	t/d
Request Corrupted CRC	0101 0011	o	d	t/d
Notify of Corrupted CRC	0101 0100	o	d	t/d
Return to Normal	1111 1111	o	d	t/d
Hold State	0000 0000	d/o	o/d	o/d/t
Unable to Comply Acknowledgement	1010 1010	d	o	t/o

* The use of B1 and B2 channel loopbacks is optional. However, the loopback codes are reserved for these functions.

64 EOC messages have been reserved for non-standard applications in the following 4 blocks of 16 codes each (x is ONE or ZERO): 0100 xxxx, 0011 xxxx, 0010 xxxx, 0001 xxxx. Another 64 EOC message codes have been reserved for internal network use in the following 4 blocks of 16 codes each (x is ONE or ZERO): 0110 xxxx, 0111 xxxx, 1000 xxxx, 1001 xxxx. All remaining codes not defined in table A.2 and not reserved for non-standard applications or for internal network use are reserved for future standardisation. Therefore, 120 codes associated with the NT1 (000), and REG or other intermediate elements (001 to 110), and broadcast (111) addresses, are available for future definition; i.e. 256 total codes minus 8 defined codes from the table minus 64 codes for non-standard applications minus 64 codes for internal network use.

NOTE: The reservation of codes for non-standard applications does not in any way endorse their use. Any use of such messages shall not interfere with the EOC protocol. An NT1/REG and an LT that support messages for non-standard applications may not function properly together.

A.9 Scrambling

The data stream in each direction of transmission shall be scrambled with a 23rd-order polynomial (see figure A.5) prior to the insertion of FW.

In the LT-NT1 direction the polynomial shall be:

$$1 \oplus x^{-5} \oplus x^{-23} \text{ where } \oplus = \text{ modulo 2 summation.}$$

In the NT1-LT direction the polynomial shall be:

$$1 \oplus x^{-18} \oplus x^{-23} \text{ where } \oplus = \text{ modulo 2 summation.}$$

The binary data stream shall be recovered in the receiver by applying the same polynomial to the scrambled data as was used in the transmitter.

NOTE: Binary ONEs and ZEROs entering the NT1 transceiver from the interface at reference point T or entering the LT side transceiver from the network must appear as ONEs and ZEROs respectively, at the input of the scrambler. Also, during transmission/reception of the frame word or inverted frame word, the state of the scrambler must remain unchanged. (Caution: It is common for the input bits to be all ONEs, e.g. during idle periods or during start-up. For the ONEs to become scrambled, the initial state of the scrambling shift register must not be all ONEs).

NT1 transmit scrambler (NT1 to LT):

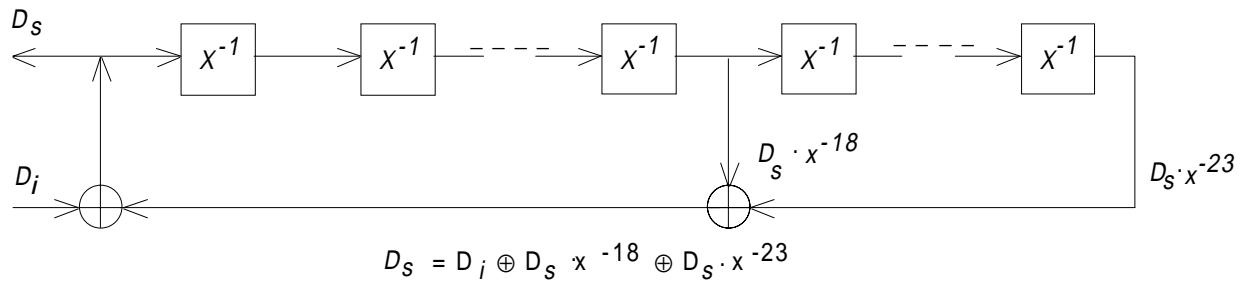

LT transmit scrambler (LT to NT1):

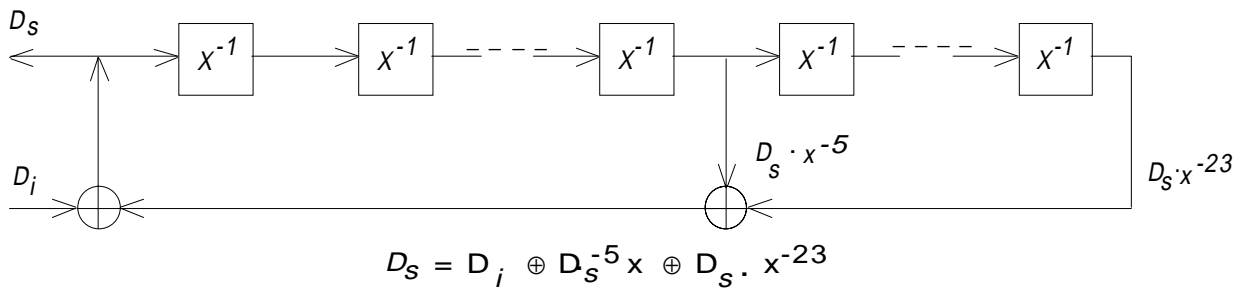

LT receive descrambler (NT1 to LT):

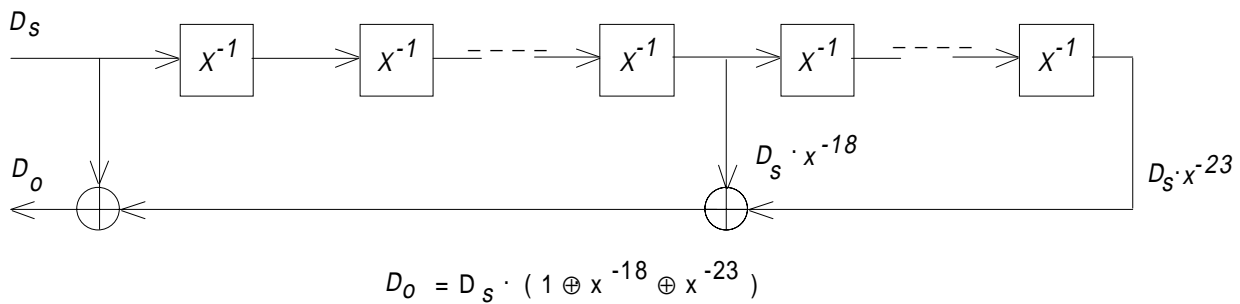

NT1 receive descrambler (LT to NT1):

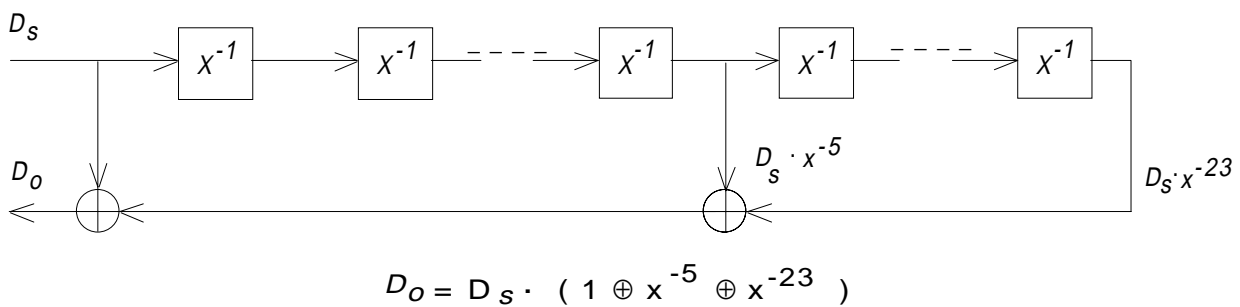

Figure A.5: Scrambler and descrambler

A.10 Start-up and control

This Clause gives requirements for the start-up and turn-off processes, including examples of activation/deactivation requests, indicators of activation and deactivation and indicators of errors. The transmission system is capable of loopbacks. These are illustrated in tables A.3 and A.4. A specification of a procedure enabling the transmission system to be activated without activating the interface at reference point T is given in the Appendix I on extension functions.

The following definitions are for the purpose of clarifying requirements which follow:

- 1) **Total Activation:** The word activation is used here to describe a process that includes the start-up process as given in (2) below and activation as given in ETS 300 012 [9].
- 2) **Start-Up:** A process characterised by a sequence of signals produced by the LT and by the NT1. Start-up results in establishment of the master-slave mode, i.e. synchronization of the receivers and the training of equalisers and echo cancelers to the point that two-way transmission requirements are met.
- 3) **Warm-Start:** The start-up process that applies to transceivers meeting the optional warm-start activation-time requirements after they have once been synchronized and have subsequently responded to a deactivation request. Warm start applies only if there have been no changes in line characteristics and equipment. Transceivers that meet warm-start requirements are called warm-start transceivers.
- 4) **Cold-Start:** The start-up process that applies to transceivers that either do not meet optional warm-start activation-time requirements, or have not been continuously in a deactive state that resulted from a deactivation request to the NT1. Cold-start also applies if there have been changes in line characteristics or equipment or both. A cold-start shall always start from the RESET state.
- 5) **Cold-Start-Only:** NT1 transceivers that do not meet optional warm-start activation-time requirements (see subclause A.10.6) are called cold-start-only transceivers. The use of cold-start-only transceivers is outside the scope of this ETR.
- 6) **Full Operational Status:** Full operational status of a transceiver means that it has:
 - a) acquired bit timing (for NT1), bit timing phase (for LT), and frame synchronization from the incoming signal from the other transceiver;
 - b) recognized the incoming multiframe marker; and
 - c) fully converged both echo canceller and equalizer coefficients.
- 7) **Deactivation:** The word deactivation is used here to describe a process that includes the turn-off process as given in 8) below and deactivation of the S/T interface as given in ETS 300 012 [9].
- 8) **Turn-off:** The process by which a pair of fully operational transceivers transition to the RESET state.
- 9) **RESET:** The RESET state consists of two sub-states: the RECEIVE RESET and the FULL RESET states. In other Clauses, the term RESET is used to refer to the FULL RESET state.

RESET has no implications about the state of convergence of the equalizer or echo canceler coefficients of the transceiver.

For specific transceiver implementations, RESET states (or sub-states) may mean different and possibly multiple internal states.

- 10) **FULL RESET:** The FULL RESET state is one in which a transceiver has detected the loss of signal from the far-end and is not transmitting (sending signal to the DLL).

The FULL RESET state shall also be entered following power up.

While in FULL RESET, NT1s may initiate transmission only if responding to a new power off/on cycle or to a new request for service from the customer Terminal Equipment (TE). Under all other conditions, where the transceivers have been turned-off (see subclause A.10.1.5.2), the NT1s shall remain quiet, i.e. they shall not start transmitting any signal until they have received the TL signal (start-up tone) from the network.

- 11) **RECEIVE RESET:** The RECEIVE RESET state is a transient state in which NT1 has detected the loss of signal from the far-end and is not transmitting (sending signal to the DLL). In addition, the transceiver is not permitted to initiate the start-up sequence (send wake-up tone) but shall be capable of responding to the start-up sequence (detecting wake-up tone). Unless it responds to a wake-up tone, an NT1 must remain in this state for at least 40 ms, after detecting the loss of received signal, as specified in subclauses A.10.1.5.2 and A.10.2, after which time, the transceiver shall enter the FULL RESET state.
- 12) **Power Down Mode:** Power down is required to permit the digital transmission system to be placed in a low power consumption mode when no calls are in progress. The NT1 consumes less power but is capable of detecting TL from the network side and/or INFO1 from the user side.
- 13) **Transparency:** The word transparency is used to mean that the B₁-channel, B₂-channel, and D-channel (2B+D) bits received by the transceiver on the interface are passed to the TE at the NT and to the network at the LT. Likewise, when a transceiver is transparent, 2B+D bits sent to the transceiver at the LT from within the network, or at the NT from the TE, are transmitted on the interface. Conversely, when a transceiver is not transparent, 2B+D bits received on the interface are not passed along to the TE at the NT or to the network at the LT. Likewise, when a transceiver is not transparent, 2B+D bits from within the network at the LT or from the TE at the NT are not transmitted on the interface. Transparency applies separately to each transceiver. Conditions for transparency are discussed in subclause A.10.3.4.

A.10.1 Signals used for start-up and control

A.10.1.1 Signals during start-up

Figure A.6 defines the signals produced by the transceivers during start-up. These signals apply during both types of start-up; i.e. cold-start and warm-start. During start-up, all signals at the interface shall consist of sequences of symbols of the shape defined in subclause A.13.2.

With the exception of the wake-up tones (TN and TL), the scrambler shall be used in the normal way in formulating the signals. For example, figure A.7 shows ONEs for B and D channel bits and the overhead bits in the signal SN1. These ONEs are scrambled before coding, producing random pulses in these positions at the interface.

Except where noted otherwise in figure A.7, all the pulse sequences are framed and multiframed in accordance with the normal frame structure shown in figures A.1, A.2 and A.3 and all pulses represent scrambled bits except those in the frame word. The signals TN and TL are 10 kHz tones generated by repeating the following unscrambled and unframed symbol pattern:

... +3 +3 +3 +3 -3 -3 -3 -3 ...

A.10.1.2 Line rate during start-up

During start-up, the network shall produce symbols at the nominal line rate within the tolerance specified in subclause A.2.1.2.

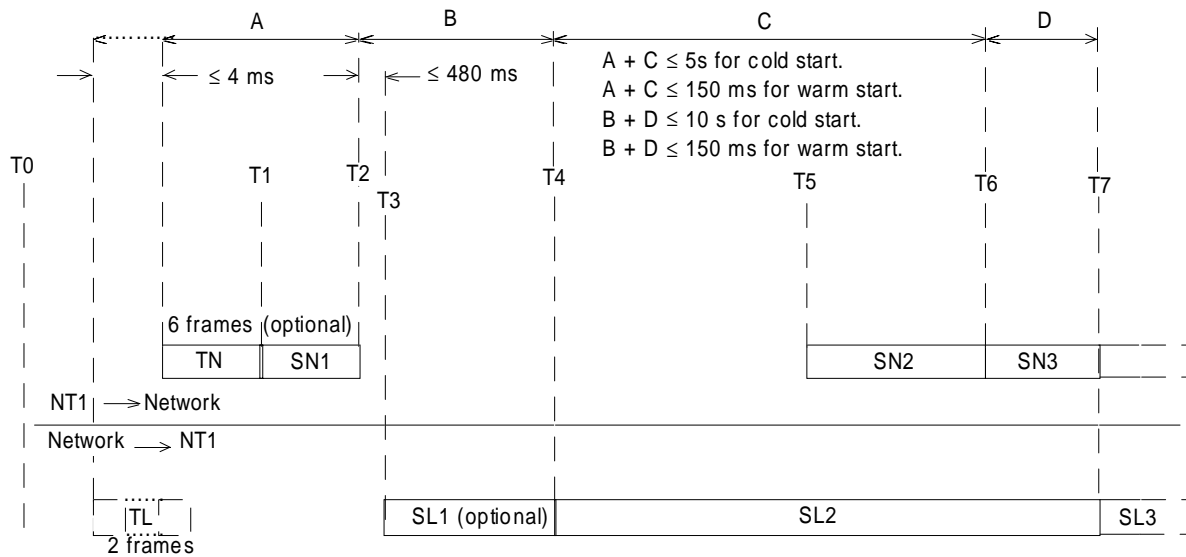

Time: Description of event or state:

- T0 RESET state.
- T1 Network and NT1 are awake.
- T2 NT1 discontinues transmission, indicating that the NT1 is ready to receive signal.
- T3 Network responds to termination of signal and begins transmitting signal towards to NT1.
- T4 Network begins transmitting SL2 towards the NT1, indicating that the network is ready to
- T5 NT1 begins transmitting SN2 towards the network, indicating that NT1 has acquired FW
- T6 NT1 has acquired multiframe marker and is fully operational.
- T7 Network has acquired multiframe marker and is fully operational.

Figure A.6: State sequence for transceiver start-up

A.10.1.3 Start-up sequence

Figure A.6 shows the sequence of signals at the interface that are generated by the transceivers. The transition points in the sequence are also defined in figure A.7. For further information on the events at the interface at reference point T, see ETS 300 012 [9].

A.10.1.4 Wake-up

When transceivers are in the RESET state or are deactivated, as a result of responding to a deactivation request, either transceiver may initiate start-up by sending a tone as defined in figure A.7.

A.10.1.5 Progress indicators

A.10.1.5.1 Start-up

In the NT1 to LT direction, the ACT bit remains set to ZERO until the customer equipment indicates progress in getting ready to transmit. The corresponding action at the T reference point in the customer equipment is receipt of the signal INFO3. To communicate this progress indication, ACT from the NT1 is set to ONE. Assuming INFO3 occurs before T6 and T7, this progress indication shall not affect overhead symbols at the interface until T6, when the NT1 overhead bits are allowed to be normal, and may not be detected by the LT until T7.

After event T7 (see figure A.6) and after ACT = ONE is received from the NT1, the LT sets the ACT bit to ONE to communicate readiness for layer 2 communication (see subclause A.8.3.2.2).

A.10.1.5.2 Deactivation

All transceivers shall cease transmission following loss of received signal. There are different turn-off procedures for transceivers that have achieved full operational status than for transceivers that have not (see subclause A.10.2).

The network may take advantage of the capabilities of warm-start NT1s by announcing turn-off. In announcing turn-off, the network shall change DEA from ONE to ZERO in at least three consecutive multiframes before ceasing transmission. It shall cease transmission before sending the DEA bit in the multiframe following the multiframe in which DEA = ZERO is sent for the last time.

During multiframes with DEA = ZERO, the NT1 has time to prepare for turn-off.

After the warm-start NT1 has prepared itself for turn-off, it shall upon detection of loss of signal from the network, cease transmission, and enter the RECEIVE RESET state within 40 ms of the occurrence of the transition to no signal at its interface. As specified in subclause A.10.2, unless it responds to a TL signal from the network, it shall not initiate the transmission of wake-up tone for a period of at least 40 ms after it ceases transmission, and then it shall enter the FULL RESET state.

The network side transceiver, after announcing turn-off and ceasing transmission, shall enter the FULL RESET state upon detection of loss of received signal from the NT1.

Although NT1s are not permitted to initiate turn-off, the LT shall respond to loss of signal as stated above.

A.10.2 Timers

Timers shall be used to determine entry into the RESET states. Upon the occurrence of any of the following conditions:

- 1) failure to complete start-up within 15 s (warm or cold start);
- 2) loss of received signal for more than 480 ms; or
- 3) loss of synchronization for more than 480 ms.

A transceiver shall cease transmission and, as specified in subclause A.10.2, enter the RECEIVE RESET state and remain for at least 40 ms, (unless it responds to a wake-up tone) after which it shall enter the FULL RESET state. The manner of entering the RECEIVE RESET state is different for the different conditions listed above.

For conditions 1) or 3), it shall cease transmission and then, upon the subsequent detection of the loss of received signal, the transceiver shall enter the RECEIVE RESET state. Its response time to a loss of signal (after conditions 1) or 3) have been satisfied) shall be such that it shall enter the RECEIVE RESET state and be capable of responding to the initiation of wake-up tone by the far-end transceiver within 40 ms after the far end transceiver ceases transmission.

For condition 2), the transceiver shall immediately enter the RECEIVE RESET state.

For conditions 2) and 3), these requirements apply to transceivers after multiframe synchronisation is achieved (see T6 and T7 in figure A.6).

In addition, an NT1 shall enter the FULL RESET state if signal is not received within 480 ms after it ceases the transmission of TN, or SN1 if it is sent (see T2 to T3 in figures A.6 and A.7).

A.10.3 Description of the start-up procedure

A.10.3.1 Start-up from customer equipment

While the NT1 and LT remain in the deactive state as a result of receiving and responding to a deactivation request, or while they are in RESET, a request for activation from the customer equipment shall result in the TN signal (tone) being sent from the NT1 toward the LT. The LT, on receiving TN shall remain silent until detection of cessation of signal from the NT1. The rest of the sequence then follows as indicated in figures A.6 and A.7. If the LT happens to try to activate at the same time it may send a TL tone during the TN tone without harm.

For cold-start-only NT1s, start-up shall be attempted upon NT1 power-up. After an unsuccessful start-up attempt, the NT1 DLL transceiver may enter FULL RESET.

While in the RESET state, NT1s may initiate transmission only if responding to a new power off/on cycle or a new service request. Under all other conditions where the system has been deactivated, the NT1s shall remain quiet, i.e. they shall not start transmitting any signal until the NT1 has received the TL signal from the LT.

A.10.3.2 Start-up from the network

While the NT1 and LT remain in the deactive state as a result of receiving and responding to a deactivation request, or while they are in RESET, a request for activation from the LT shall result in the TL signal being sent from the LT toward the NT1. The NT1, on receiving TL shall respond with TN within 4 ms from the beginning of TL. The rest of the sequence then follows as indicated in figures A.6 and A.7.

A.10.3.3 Sequence charts

Examples of sequence charts for start-up by both terminal and ET equipment are given in figures A.8 and A.9.

Signal	Frame Word (FW)	Multi-frame (IFW)	2B+D	M	Start	Stop	Time (Frames)
TN	$\pm 3 \ddagger$	$\pm 3 \ddagger$	$\pm 3 \ddagger$	$\pm 3 \ddagger$	†	†	6
SN1	Present	Absent	1	1	T1	T2	-
SN2	Present	Absent	1	1	T5	T6	-
SN3	Present	Present	Normal ⁺	Normal	T6	*	-
TL	$\pm 3 \ddagger$	$\pm 3 \ddagger$	$\pm 3 \ddagger$	$\pm 3 \ddagger$	†	†	2
SL1	Present	Absent	1	1	T3	T4	-
SL2	Present	Present	0	Normal	T4	T7	-
SL3	Present	Present	Normal ⁺	Normal	T7	*	-

Symbols and abbreviations:

- \ddagger Tones have alternating pattern of four +3 symbols followed by four -3 symbols and no FW.
- † See figure A.6 and subclause A.10.1.3 for start and/or stop time of this signal.
- TN, TL Tones produced by NT1 or LT, respectively (see subclause A.10.1.1).
- SNx, SLx Pulse patterns produced by NT1 or LT, respectively.
- Tx Notation refers to transition instants defined in figure A.6.
- Absent Under multiframe, this notation means only that FW is transmitted instead of IFW.
- Normal Normal means that the M bits are transmitted onto the 2-wire line as required during normal operation; e.g. valid CRC bits, EOC bits and indicator bits are transmitted.
- Normal⁺ Except to perform a loopback, 2B+D bits shall remain in the previous state (SN2 or SL2) until both ACT bits indicate full transparency of the B and D channels (i.e. the 2B+D bits of SN3 and SL3 shall remain set to ONE and ZERO, respectively, until transparency is achieved at both ends of the DLL).
- * Signals SN3 and SL3 continue indefinitely (or until turn-off).

Figure A.7: Definitions of signals during start-up

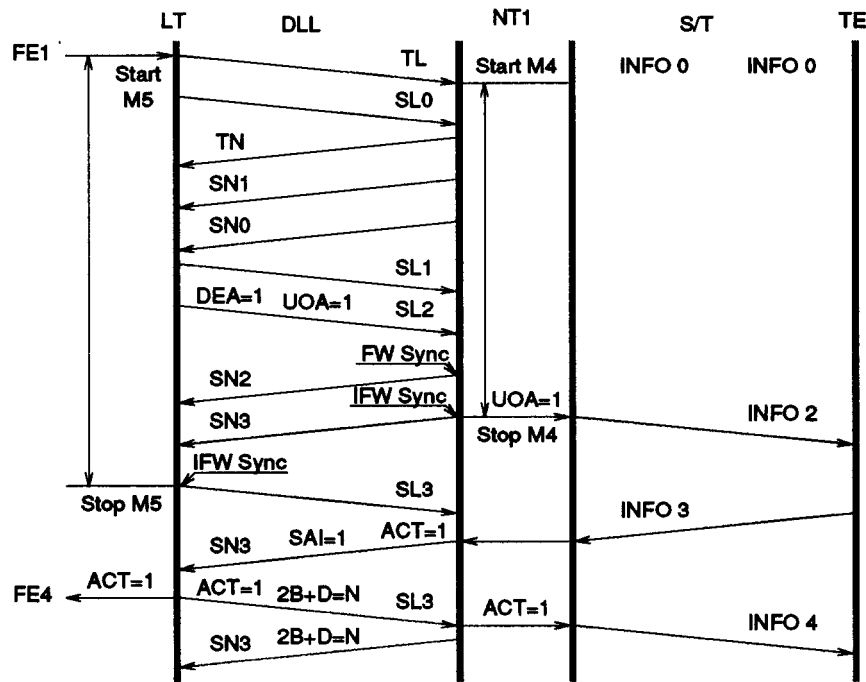

NOTE 1: Receipt of INFO3 and SL3 at the NT1 can theoretically occur in either order.
 NOTE 2: For symbols and abbreviations see table A.5.
 NOTE 3: The reading of the UOA bit is necessary only when the option "DLL-only turn-on" is implemented.

Figure A.8: Total activation initiated by the exchange

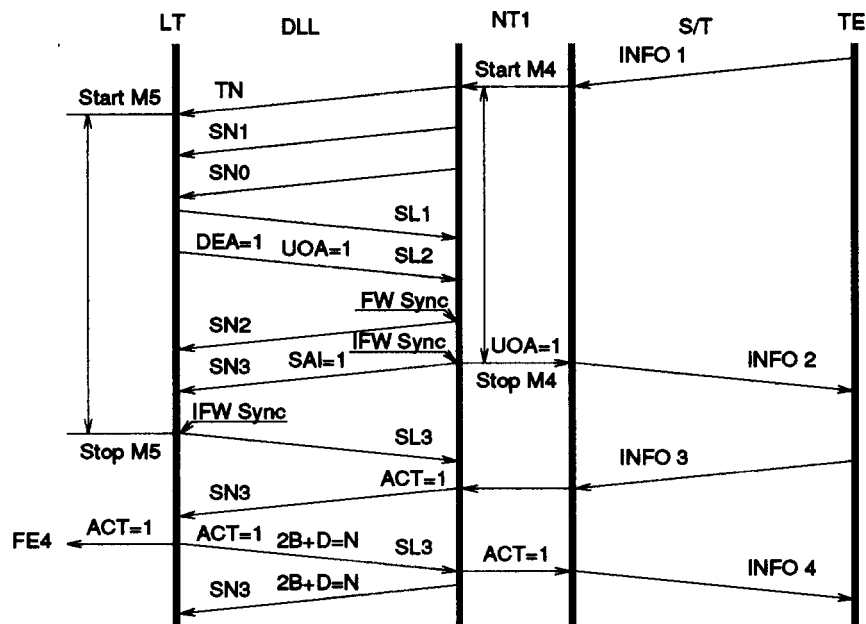

NOTE 1: Receipt of INFO3 and SL3 at the NT1 can theoretically occur in either order.
 NOTE 2: For symbols and abbreviations see table A.5.
 NOTE 3: The reading of the UOA bit is necessary only when the option "DLL-only turn-on" is implemented.

Figure A.9: Total activation initiated by terminal equipment

A.10.3.4 Transparency

Transparency of the transmission in both directions by the NT1 shall be provided after the NT1 achieves full operational status (T6), and both ACT = ONE from the LT and DEA = ONE. Full operational status of the NT1 means that the NT1 has:

- 1) acquired bit timing and frame synchronization from the incoming signal from the LT;
- 2) recognized the multiframe marker from the LT; and
- 3) fully converged both its echo canceller and equalizer coefficients.

Transparency of the transmission in both directions at the LT shall be provided when the LT:

- 1) achieves full operational status (T7);
- 2) detects the presence of the multiframe marker from the NT1; and
- 3) receives ACT = ONE from the NT1.

Full operational status at the LT means that the LT has:

- 1) acquired bit timing phase of the incoming signal from the NT1 and frame synchronization;
- 2) recognized the multiframe marker from the NT1; and
- 3) fully converged both its echo canceller and equalizer coefficients.

At the LT, transparency of the B-channels and D-channel shall occur at any time during either the first LT transmitted super frame with ACT = ZERO or during the last LT transmitted super frame with ACT = ZERO. Transparency occurs at the transition from all ZEROS to "Normal" in the B-channels and D-channel in SL3. For example, referring to figure A.1, suppose super frame A is the last transmit super frame with ACT = ZERO, super frame B is the first transmit super frame with ACT = ONE, and super frames C and D continue with ACT = ONE. The transition to transparency may occur not later than the first bit of super frame C. This means that all B-channel and D-channel bits in super frames C and D shall be transmitted transparently, provided that conditions for transparency have been maintained.

At the LT, transparency of the B-channels and D-channels in the LT to network direction, may occur at a different time than transparency in the LT to NT1 direction. However, in both directions the LT shall become transparent during the two transmit super frames A and B described in the example. The NT may not yet have achieved transparency during this interval.

After both the LT and the NT1 achieve transparency in both directions, the ACT bits shall continue to reflect the state of readiness of the LT and the terminal equipment for layer 2 communication. The ACT bit in the LT to NT1 direction shall reflect the status of the LT side of the interface. The ACT bit in the NT1 to LT direction shall reflect the status of the NT1 side of the interface. Whenever either end, for any reason, loses its readiness to communicate at layer 2 (e.g. the terminal is unplugged), that end shall set its transmitted ACT bit to ZERO. A change of status of this bit shall be repeated in at least three consecutive transmitted multiframes.

A.10.4 State transition table for the NT1

Table A.3 provides an example of a state transition table for the NT1 as a function of INFOs, SIGs, and timers.

A.10.5 State transition table for the LT

Table A.4 provides an example of a state transition table for the LT as a function of FEs, SIGs, and timers.

Table A.3: State transition table for the NT1 as a function of INFOS SIGs and timers - with loopback 2 : an example

Event ↓ v	State name	Power off	Full reset	Alerting	EC Training (optional)	EC converged	FW sync	IFW sync	Pending active	Active	Pending deactivation	Tear down	Receive reset	Loopback 2 initiated	Loopback 2 pending	Loopback 2 operated
	State code (fig. A.6 event)	NT0	NT1 (T0)	NT2	NT3 (T1)	NT4 (T2)	NT5 (T5)	NT6 (T6)	NT7	NT8	NT9	NT10	NT12	NT6A	NT7A	NT8A
	Signal --> LT	SN0	SN0	TN	SN1	SN0	SN2	SN3 ACT=0	SN3 ACT=1	SN3 ACT=1	SN3 (NOTE 8)	SN0	SN0	SN3 ACT=0	SN3 ACT=1	SN3 ACT=1
Signal --> TE (NOTE 2)	INFO 0	INFO 0	INFO 0	INFO 0	INFO 0	INFO 0	INFO 0	INFO 2	INFO 2	INFO 4		INFO 0	INFO 0	INFO 2 (NOTE 17)	INFO 2 (NOTE 17)	INFO 4 (NOTE 17)
Power ON	ST.M4 NT2	-	-	-	-	-	-	-	-	-	-	-	-	-	-	-
Loss of power	-	NT0	NT0	NT0	NT0	NT0	NT0	NT0	NT0	NT0	NT0	NT0	NT0	NT0	NT0	NT0
Received new INFO 1 (NOTE 2)	/	ST.M4 NT2 (NOTE 12)	-	-	-	-	-	-	/	/	-	-	-	/	/	/
Receive INFO 3 (SL2 or SL3) (ACT=0, DEA=1) (NOTE 2)	/	/	/	/	/	/	/	NT7	-	-	-	-	-	NT7A (NOTE 17)	-	-
INFO 0 (LOS/LFA at T) (SL2 or SL3) (NOTE 2)	/	-	-	-	-	-	-	-	NT6	NT6	-	-	-	-	NT6A (NOTE 17)	NT6A (NOTE 17)
End of tone TN (9 ms)	/	/	NT3 or NT4	/	/	/	/	/	/	/	/	/	/	/	/	/
Received tone TL	/	ST.M4 NT2	-	/	/	/	/	/	/	/	/	/	ST.M4 STP.M6 NT2	/	/	/
Echo canceller converged	/	-	-	NT4	-	-	-	-	-	-	-	-	-	-	-	-
FW sync and detect SL2	/	/	/	/	NT5	-	-	-	-	-	-	-	/	-	-	-
IFW sync (SL2)	/	/	/	/	/	STP.M4 NT6	-	-	-	-	-	-	/	-	-	-

(continued)

Table A.3 (concluded): State transition table for the NT1 as a function of INFOs SIGs and timers - with loopback 2 : an example

Event ↓ √	State name	Power off	Full reset	Alerting	EC Training (optional)	EC converged	FW sync	IFW sync	Pending active	Active	Pending deactivation	Tear down	Receive reset	Loopback 2 initiated	Loopback 2 pending	Loopback 2 operated
	State code (fig. A.6 event)	NT0	NT1 (T0)	NT2	NT3 (T1)	NT4 (T2)	NT5 (T5)	NT6 (T6)	NT7	NT8	NT9	NT10	NT12	NT6A	NT7A	NT8A
	Signal --> LT	SN0	SN0	TN	SN1	SN0	SN2	SN3 ACT=0	SN3 ACT=1	SN3 ACT=1	SN3 (NOTE 8)	SN0	SN0	SN3 ACT=0	SN3 ACT=1	SN3 ACT=1
Signal --> TE (NOTE 2)	INFO 0	INFO 0	INFO 0	INFO 0	INFO 0	INFO 0	INFO 0	INFO 2	INFO 2	INFO 4		INFO 0	INFO 0	INFO 2 (NOTE 17)	INFO 2 (NOTE 17)	INFO 4 (NOTE 17)
Received DEA=0 (SL2 or SL3) (NOTE 6)	/	/	/	/	/	/	/	NT9	NT9	NT9	-	-	/	NT9	NT9	NT9
Received (SL2 or SL3) ACT=0 and DEA=1	/	/	/	/	/	/	/	-	-	NT7	NT6,NT6A NT7,NT7A (NOTE 13)	-	/	-	-	NT7A
Received (SL3) ACT=1and DEA=1	/	/	/	/	/	/	/	-	NT8	-	NT8, NT8A (NOTE 13)	-	/	-	NT8A	-
Loss of synchronisation (> 480 ms)	/	/	/	/	/	/	/	NT10	NT10	NT10	NT10	-	-	NT10	NT10	NT10
Loss or absence of signal (> 480 ms) (NOTE 14)	/	/	/	/	/	STP.M4 NT1	-	ST.M6 NT12	ST.M6 NT12	ST.M6 NT12	/	/	-	ST.M6 NT12	ST.M6 NT12	ST.M6 NT12
Expiry of timer M4 (15 seconds)	/	/	/	/	NT10	NT10	NT10	/	/	/	/	/	-	/	/	/
Loss of signal < 40 ms	/	/	/	/	/	-	-	-	-	-	ST.M6 NT12	ST.M6 NT12	/	-	-	-
Expiry of timer M6 (40 ms)	/	/	/	/	/	/	/	/	/	/	/	/	NT1	/	/	/
Received EOC (SL3) "Loopback 2" request (NOTE 18)	/	/	/	/	/	/	/	NT6A	NT6A	NT6A	/	/	/	-	-	-
Received EOC "Return to Normal" Request	/	/	/	/	/	/	/	-	-	-	-	-	/	NT6 (NOTE 19)	NT6 (NOTE 19)	NT6 (NOTE 19)

NOTE: For symbols, abbreviations and NOTEs, see table A.5.

Table A.4: State transition table for the LT as a function of FEs SIGs and timers - with loopback 2 : an example

Event ↓ V	State name	Power off	Full reset	Alerting	Awake	EC Training (optional)	EC converged	FW sync	IFW sync	Active	Deactivation alerting	Tear down	Pending deactivation	Receive reset	Loopback 2 requested	Loopback 2 operated
	State code (fig. A.6 event)	LT0	LT1 (T0)	LT2	LT3 (T1)	LT4 (T3)	LT5 (T4)	LT6	LT7 (T7)	LT8	LT9	LT10	LT11	LT12	LT7A	LT8A
	Signal --> NT	SL0	SL0	TL	SL0	SL1	SL2 DEA=1 ACT=0	SL2 DEA=1 ACT=0	SL3 DEA=1 ACT=0	SL3 DEA=1 ACT=1	SL3 DEA=0 ACT=0	SL0	SL0	SL0	SL3 DEA=1 ACT=0 (NOTE 17)	SL3 DEA=1 ACT=1 (NOTE 17)
Power ON	LT1	-	-	-	-	-	-	-	-	-	-	-	-	-	-	-
Loss of power (NOTE 1)	-	LT0 FE7	LT0 FE7	LT0 FE7	LT0 FE7	LT0 FE7	LT0 FE7	LT0 FE7	LT0 FE7	LT0 FE7	LT0 FE7	LT0 FE7	LT0 FE7	LT0 FE7	LT0 FE7	LT0 FE7
Activation request (FE1) or "Loopback 2 Request" (FE8) (NOTE 1)	-	ST.M5 LT2 FE2	-	-	-	-	-	-	-	-	-	-	-	-	-	-
Deactivation request (FE5) (NOTES 1 and 9)	-	-	-	-	-	-	-	LT9	LT9	-	-	-	-	LT9	LT9	
End of tone TL (3 ms) Continue FE1 or FE8 (NOTE 1)	/	/	LT3	/	/	/	/	/	/	/	/	/	/	/	/	/
Received tone TN Continue FE1 or FE8 (NOTE 1)	/	ST.M5 LT3 FE2	-	-	/	/	/	/	/	/	/	/	/	ST.M5 STP.M7 LT3 FE2	/	/
Loss of signal energy (TN or SN1) Continue FE1 or FE8 (NOTE 1)	/	/	-	LT4 or LT5	-	/	/	/	/	/	/	/	/	/	/	/
Echo canceller converged Continue FE1 or FE8 (NOTE 1)	/	-	-	-	LT5	-	-	-	-	-	-	-	-	-	-	-
FW sync (SN2 or SN3) Continue FE1 or FE8 (NOTE 1)	/	/	/	/	/	LT6	-	-	-	-	-	-	-	/	-	-
(continued)																

Table A.4 (concluded): State transition table for the LT as a function of FEs SIGs and timers - with loopback 2 : an example

Event ↓ V	State name	Power off	Full reset	Alerting	Awake	EC Training (optional)	EC converged	FW sync	IFW sync	Active	Deactivation alerting	Tear down	Pending deactivation	Receive reset	Loopback 2 requested	Loopback 2 operated
	State code (fig. A.6 event) Signal --> NT	LT0	LT1 (T0)	LT2	LT3 (T1)	LT4 (T3)	LT5 (T4)	LT6	LT7 (T7)	LT8	LT9	LT10	LT11	LT12	LT7A	LT8A
		SL0	SL0	TL	SL0	SL1	SL2 DEA=1 ACT=0	SL2 DEA=1 ACT=0	SL3 DEA=1 ACT=0	SL3 DEA=1 ACT=0	SL3 DEA=1 ACT=1	SL3 DEA=0 ACT=0	SL0	SL0	SL0	SL3 DEA=1 ACT=0 (NOTE 17)
	IFW sync (SN3) Continue FE1 or FE8 (NOTE 1)	/	/	/	/	/	/	STP.M5 LT7 FE3	-	-	-	-	-	/	-	-
	Received ACT=0 (SN3) (NOTE 1)	/	/	/	/	/	/	/	-	LT7 FE12	-	-	-	/	-	LT7A FE12
	Received ACT=1 (SL3) (FE1) (NOTE 1)	/	/	/	/	/	/	/	LT8 FE4	-	-	-	-	/	LT8A FE4	-
	Loss of synchronisation (> 480 ms) (NOTE 1)	/	/	/	/	/	/	/	LT10 FE7	LT10 FE7	LT10 FE7	-	-	-	LT10 FE7	LT10 FE7
	Loss or absence of signal (> 480 ms) (NOTE 1)	/	/	/	LT1	/	-	-	ST.M7 LT12 FE7	ST.M7 LT12 FE7	ST.M7 LT12 FE7	-	-	-	ST.M7 LT12 FE7	ST.M7 LT12 FE7
	End of last super frame with DEA=0 (FE5) (NOTE 10)	/	/	/	/	/	/	/	/	/	LT11	/	/	/	-	/
	Expiry of timer M5 (15 seconds) (NOTE 1)	/	/	/	LT10 FE7	LT10 FE7	LT10 FE7	LT10 FE7	/	/	/	/	/	/	/	/
	Absence of signal < 40 ms (NOTE 1)	/	-	/	/	/	-	-	-	-	-	ST.M7 LT12	LT1 FE6	-	-	-
	Expiry of timer M7 (40 ms) (NOTE 1)	/	/	/	/	/	/	/	/	/	/	/	/	LT1 FE6	/	/
	Loopback 2 Request (FE8) (NOTES 1 and 18)	/	/	/	/	/	/	/	LT7A	LT7A	-	-	-	-	-	-
	Return to Normal Request	/	/	/	/	/	/	/	-	-	-	-	-	-	(NOTE 19) LT7 FE12	(NOTE 19) LT7 FE12

NOTE: For symbols, abbreviations and NOTES, see table A.5.

Table A.5: Symbols, abbreviations and NOTES for tables A.3 and A.4

Symbols and abbreviations:		
"-"	=	No change, no action.
"/"	=	Impossible or prohibited situation under normal circumstances.
"FE1"	=	Activate Access Request (AR) (NOTE 1).
"FE2"	=	Access Activation Initiated (NOTE 1).
"FE3"	=	Line Transceivers Activated (NOTE 1).
"FE4"	=	Access Activated or Loopback Operated (AI) (NOTE 1).
"FE5"	=	Deactivate Access Request (NOTE 1).
"FE6"	=	Access or Loopback Deactivated (DI) (NOTE 1).
"FE7"	=	LOS/LFA in Line Transceivers - (including Loss of Power at NT1) (NOTE 1).
"FE8"	=	Activate Loopback 2 (NOTE 1).
"FE9"	=	Activate Loopback 1 (at LT towards network) (NOTE 1).
"FE10"	=	Activate Loopback 1a (at Regenerator towards network) (NOTE 1).
"FE11"	=	Partial Activation Request (UOA) (see subclause A.8.3.2.7) (NOTE 1).
"FE12"	=	Report LOS/LFA at T reference point (see subclause A.8.3.2.8).
"FE13"	=	Deactivate the interface at T reference point whilst keeping the Access Digital Section activated (NOTE 1).
"NTn"	=	Go to state "NTn".
"LTn"	=	Go to state "LTn".
"ST.Mn"	=	Start timer Mn.
"STP.Mn"	=	Stop timer Mn.
"SLn,SNn"	=	Signals defined in figures A.6 and A.7 (SL0, SN0 = no signal).
"Tn"	=	Events defined in figures A.6 and A.7.
NOTES:		
NOTE 1:	The function elements are also defined in ETS 300 297 [8], subclause 8.4.3.	
NOTE 2:	INFO signals at the T reference point are defined in ETS 300 012 [9], subclause A.6.2.2.	
NOTE 3:	Deleted.	
NOTE 4:	Deleted.	
NOTE 5:	Deleted.	
NOTE 6:	Cold-start-only NTs may ignore this event.	
NOTE 7:	Deleted.	
NOTE 8:	The signals output in this state remain unchanged from signals output during the preceding state (for example, ACT=0 if state NT6 preceded, or ACT=1 if states NT7 or NT8 preceded). The INFOs also remain unchanged.	
(continued)		

Table A.5 (continued) Symbols, abbreviations and NOTES for tables A.3 and A.4

- NOTE 9: This event is only the first step of a sequence leading to deactivation. After transmitting DEA=0 for a short interval (see NOTE 10), the LT sends SL0 to deactivate the NT.
- NOTE 10: This event occurs as a result of FE5 (see NOTE 9) after entering state LT9 and transmitting at least three super frames with DEA=0 (see subclause A.10.1.5).
- NOTE 11: Deleted.
- NOTE 12: When INFO 1 remains continuous after the NT fails to bring up the network side and returns to state NT1, the NT does not go again into state NT2 unless a new transition from INFO 0 to INFO 1 is received (see Clause A.10 (10) and ETS 300 012).
- NOTE 13: The transceiver should return to the state from which it entered state NT9, unless the UOA or ACT bit(s) have changed.
- NOTE 14: The transitions resulting from this event, to either full reset (NT1) or receive reset (NT12), are controlled by the requirements in subclause A.10.2.
- NOTE 15: The network is permitted to choose "No action" rather than sending FE1 and transferring to state LT7. For example, when the access link is undergoing maintenance, "No action" is an appropriate response.
- NOTE 16: Deleted.
- NOTE 17: When activation is for the purpose of performing a loopback (typical means of performing loopbacks for warm-start transceivers), FE8 initiates the activation at the LT and causes the LT to send the EOC loopback command, when the LT enters state LT7. The NT has achieved synchronisation (NT6), and is sending INFO 2. If enough time elapses before confirmation of the EOC loopback command, the NT may enter state NT7 and send ACT=1 towards the LT as the TE responds with INFO 3. Furthermore, if the LT responds with ACT=1, the NT would enter NT8. It is preferable that the NT not enter NT8 in the process of responding to a loopback request (FE8). The network side should control the ACT bit sent by the LT so that it will not be sent in response to receipt of ACT=1 from the NT when the EOC loopback 2 command is being sent, or is about to be sent. This will keep the NT from entering NT8. Once the command is completed (including confirmation of correct receipt as described in subclause A.8.3.3.2), the LT should respond to ACT1 from the NT in the usual way.

(continued)

Table A.5 (continued) Symbols, abbreviations and NOTES for tables A.3 and A.4

NOTE 17 (continued):

However, when cold-start-only LTs and NTs are used, the NT may be in NT8 prior to the decision to operate loopback 2. The NT will operate the loopback if the EOC command is received during state NT8. It is not necessary to turn off the transceivers (enter RESET) prior to issuing a loopback 2 command; for cold-start-only transceivers it would be normal to allow the transceivers to remain active. But, as with warm-start transceivers, it is preferable to force ACT=0 towards the NT prior to issuing the loopback command and to release the LT to respond to ACT=1 from the NT only when the EOC command has been completed and confirmed.

When the loopback 2 command is received in states NT6, NT7 or NT8, the NT makes a transition to state NT6A. When entering NT6A from NT7 or NT8, the NT reverts to sending ACT=0 towards the LT. Furthermore, when the loopback 2 command is received in state NT8, the NT reverts to sending INFO 2 towards the TE. Also, during states NT6A, NT7A and NT8A, all INFO signals from the TE are blocked (prevented from reaching the T receiver in the NT).

In state NT6A, the event "Receive INFO 3" is taken to mean that the T receiver in the NT is synchronised (or re-synchronised) with the T transmitter in the NT. At this point, the NT enters state NT7A and sends ACT=1 towards the LT. When the LT responds with ACT=1, the NT enters state NT8A and sends INFO 4 frames towards the TE containing D-channel and B-channel bits received from the LT and with the D-echo-channel bits set to ZERO (0). On entering NT7A, and in NT8A, the NT also replaces the ONEs (1s) data in the D-channel and B-channel towards the LT (normal+ in SN3) with data contained in the INFO signal towards the TE. Transparency of the NT in the NT to LT direction to data contained in the INFO signal towards the TE is coordinated with sending ACT=1 following rules given in Clause A.10 (13) and subclause A.10.3.4. The B-channel and D-channel data from the LT towards the NT will initially be ZEROs (0s) (normal+ in SL3) until the LT becomes transparent. When the B-channel and D-channel data in the INFO signal from the NT towards the TE is used by the NT in its signal towards the LT, it will not contain the data sent by the LT until state NT8A is entered. This occurs from when the INFO signal is INFO 2 until the NT enters state NT8A. In state NT8A, both the LT and NT are transparent, the data sent from the LT is looped back towards the NT, and the loopback is also transparent, meaning that the data sent from the LT is also contained in INFO 4 towards the TE.

In states NT7A and NT8A, the event "INFO 0 (LOS/LFA at T)" is taken to mean absence of synchronisation or signal at the T receiver of the NT (the signal is either INFO 2 or INFO 4 from its own transmitter). In this case, the NT enters state NT6A (INFO 2 towards the TE and ACT=0 towards the LT). The D-channel and B-channel bits are not looped back in this case; the signal becomes all 1s in the D-channel and B-channel (normal+ in SL3).

(continued)

Table A.5 (concluded): Symbols, abbreviations and NOTES for tables A.3 and A.4

NOTE 18: The EOC request is not sent before T7 (when the LT has achieved IFW sync). The NT has already sent SN3 before the LT can reach T7. Therefore, the LT is in state LT7 or higher and the NT is in state NT6 or higher before EOC commands are sent. (Theoretically, normal overhead bits, including EOC commands, may be sent in SL2 during state LT5, but the LT cannot receive the echoes required in the EOC protocol, described in subclause A.8.3.3.2, until T7).

NOTE 19: When the loopback has been released, the LT transitions from LT8A to LT7 where, as shown in table 2, a number of additional transitions are available. For warm-start transceivers, the "Return-to-Normal" request is usually the result of a deactivation request (FE5), and in that case, the LT transitions to state LT9 and sends DEA=0. After sending DEA=0 for at least three super frames, the LT transitions to LT11 in which SL0 is sent to the NT, FE6 is sent to the ET, and the access is deactivated. In this example, the NT is initially synchronised in state NT6, where it responds to receipt of DEA=0 by entering state NT9. Even when the presence of INFO 3 from the TE causes transition to NT7, before receipt of DEA=0, the end result is the same. Because the LT is in state LT9, it does not respond with ACT=1 if the NT sends ACT=1 (NT in state NT7), and the NT does not enter NT8. The NT then deactivates on recognition of loss of signal (SL0) from the LT.

When EOC "Return to Normal" is sent without a deactivation request (FE5), (a process typically used for cold-start-only transceivers and not considered an option in these requirements) the transceivers remain synchronised in LT7 and NT6, respectively. Transparency depends on readiness for layer 2 communication at both ends and the consequent setting of ACT bits in both directions. For example, if the TE layer is already sending INFO 3 or responds with INFO 3, the NT then makes a transition to NT7. The LT will move from LT8A to LT7 (as shown) and then to LT8, where it sends ACT=1 when ACT=1 is received. After that, the NT moves to NT8 on receipt of ACT=1.

A.10.6 Activation times

The LT and the NT1 shall complete the start-up process, including synchronisation and training of equalizers to the point of meeting performance criteria within the following lengths of time:

- the digital transmission system shall start up within 300 ms without REG and 600 ms with REG on warm-starts and within 15 s on cold-starts (with and without REG);
- without REG the 15 s cold-start time requirement is apportioned such that the NT1 is allowed 5 s and the LT is allowed 10 s;
- with REG the apportionment for NT1, REG and LT is for further study;
- for warm-starts the 300 ms start-up time requirement is apportioned equally between the NT1 and the LT, 150 ms each.

See figure A.6 for details.

NOTE 1: The 300 ms requirement applies to laboratory tests only. No 300 ms timer is involved in actual in-service DLLs (see definitions in Clause A.10 for warm and cold-starts).

As indicated in figure A.6, the start time requirements cover the time span from wake-up tone to T7, and do not include time for activation of customer terminal equipment. All activation times apply only to the DLL, and do not apply to the entire customer access link where carrier systems may be involved.

NOTE 2: See subclause 8.5 in ETS 300 297 [8].

A.11 Jitter

Jitter tolerances are intended to ensure that the limits of ETS 300 012 [9] are supported by the jitter limits of the transmission system on local lines. The jitter limits given in this Clause must be satisfied regardless of the length of the local line and the inclusion of one regenerator, provided that they are covered by the transmission media characteristics (see Clause 3). The limits shall be met regardless of the bit patterns in the B, D and C_L channels.

Jitter is specified in terms of Unit Intervals (UI) of the nominal 80 kbaud signal (12,5 μs).

A.11.1 NT1 input signal jitter tolerance

The NT1 shall meet the performance objectives with wander/jitter at the maximum magnitude indicated in figure A.10, for single jitter frequencies in the range of 0,1 Hz to 20 kHz on the LT output signal with the received signal baud rate in the range of 80 kbaud ± 5 ppm. The NT1 shall also meet the performance objectives with wander per day on the LT output of up to 1,44 UI peak-to-peak where the maximum rate of change of phase is 0,06 UI/hour.

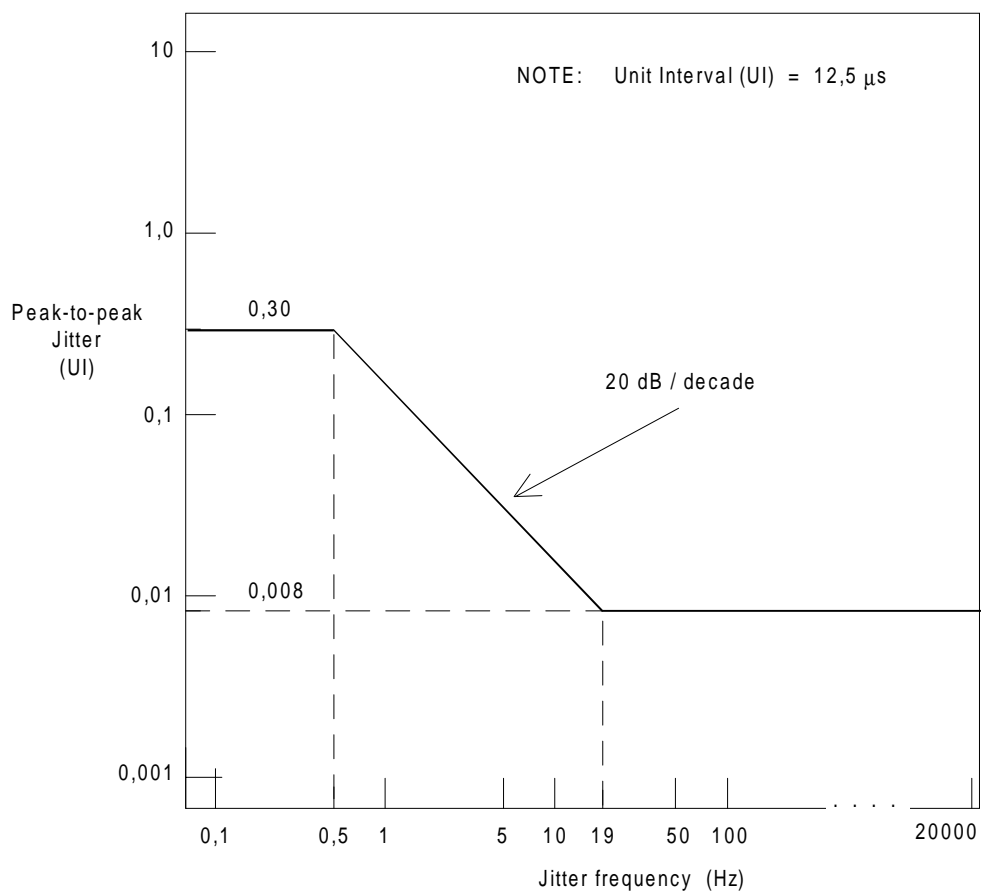

Figure A.10: Permissible sinusoidal NT1 input signal jitter

A.11.2 NT1 output jitter limitations

With the wander/jitter as specified in subclause A.11.1, superimposed on the NT1 input signal, the jitter on the transmitted signal of the NT1 towards the LT shall conform to the following, with the received signal baud rate in the range of 80 kbaud \pm 5 ppm as described in subclause A.2.1.2:

- 1) the jitter shall be equal to or less than 0,04 UI peak-to-peak and less than 0,01 UI rms when measured with a high-pass filter having a 6 dB per octave roll-off below 80 Hz;
- 2) the jitter in the phase of the output signal (the signal transmitted towards the LT) relative to the phase of the input signal (from the LT) shall not exceed 0,05 UI peak-to-peak and 0,015 UI rms when measured with a band-pass filter having a 6 dB per octave roll-off above 40 Hz and below 1,0 Hz (note that the 1,0 Hz cut-off assures that the average difference in the phase of the input and output signals is subtracted). This requirement applies with superimposed jitter in the phase of the input signal as specified in subclause A.11.1 for single frequencies up to 19 Hz;
- 3) the maximum (peak) departure of the phase of the output signal from its nominal difference (long term average) from the phase of the input signal (from the LT) shall not exceed 0,1 UI. This requirement applies during normal operation including following a "warm-start".

NOTE: This means that, if deactivated and subsequently activated in conformance with the "warm-start" requirements, the long term average difference in phase of the output signal from the phase of the input signal will be essentially unchanged.

A.11.3 LT input signal jitter tolerance

The LT shall operate satisfactorily with input signal jitter equal to the worst case NT1 output signal jitter allowed by the limits set in subclause A.11.2.

A.11.4 LT output jitter and synchronisation

The output signals from the LT shall not exceed the NT1 input signal jitter tolerance limits stated in subclause A.11.1. This requirements shall be met while maintaining data synchronisation with the network.

A.11.5 REG jitter tolerance and output jitter limitations.

For further study.

A.11.6 Test conditions for jitter measurements

Due to bidirectional transmission on the 2-wire line and due to severe intersymbol interference, no well-defined signal transitions are available at the NT1 2-wire point.

Two possible solutions are proposed:

- 1) a test point in the NT1 is provided to measure jitter with an undisturbed signal;
- 2) a standard LT transceiver including an artificial transmission line is defined as a test instrument.

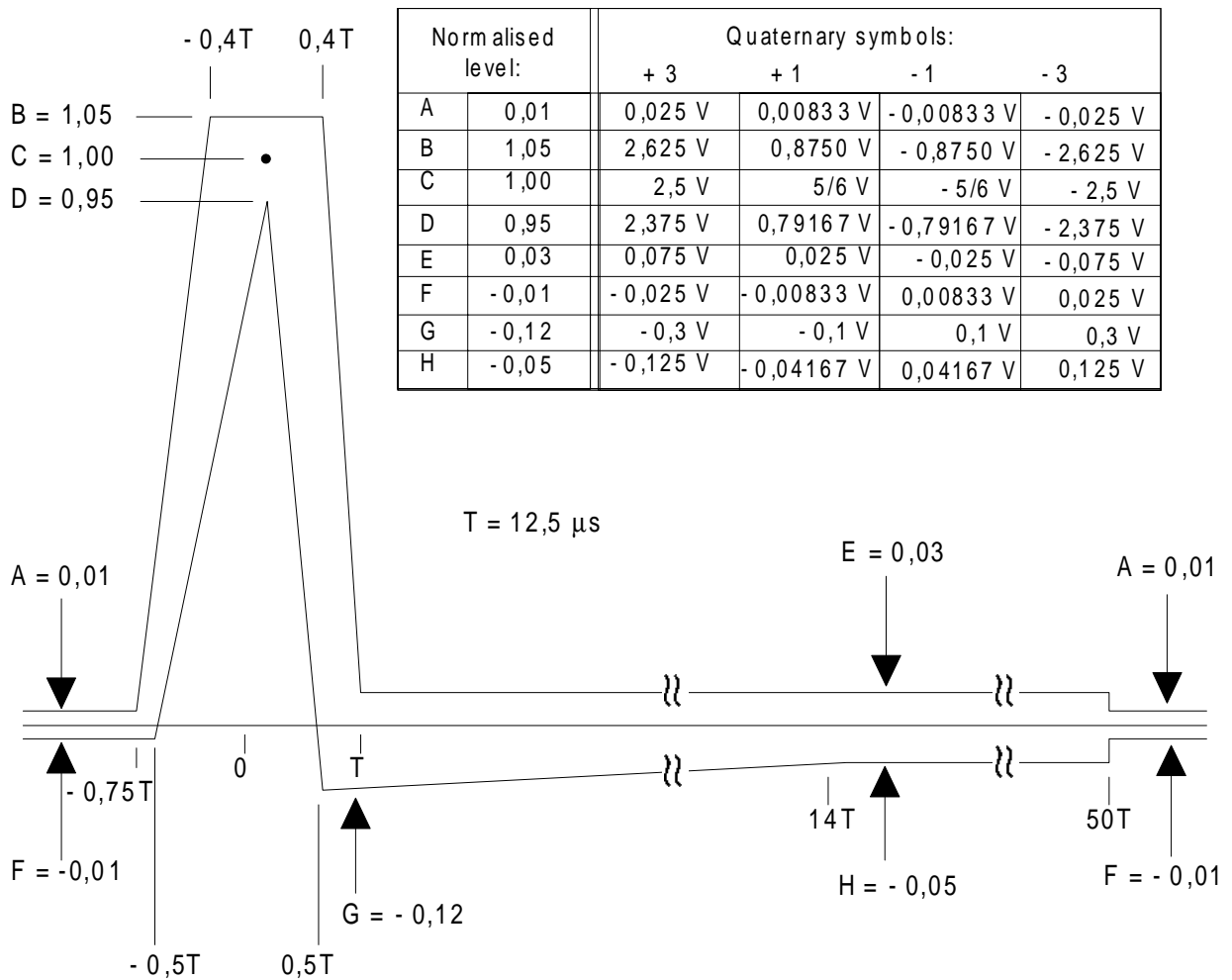

NOTE: Compliance of transmitted pulses within boundaries of the pulse mask is not sufficient to assure compliance with the power spectral density requirement and the absolute power requirement. Compliance with the requirements in subclauses A.12.3 and A.12.4 is also required.

Figure A.11: Normalised output pulse from NT1 or LT

A.12 Transmitter output characteristics of NT1, REG and LT

The following specifications apply with a load impedance of 135 Ω resistive over a frequency band of 100 Hz to 160 kHz.

A.12.1 Pulse amplitude

The nominal peak of the largest pulse shall be 2,5 (see figure A.11).

A.12.2 Pulse shape

The transmitted pulse shall have the shape specified in figure A.11. The pulse mask for the four quaternary symbols shall be obtained by multiplying the normalised pulse mask shown in figure A.11 by 2,5 V, 5/6 V, -5/6 V or -2,5 V. When the signal consists of a framed sequence of symbols with a synchronisation word and equiprobable symbols in all other positions, the nominal average power is 13,5 dBm.

A.12.3 Signal power

The average power of a signal consisting of a framed sequence of symbols with a FW and equiprobable symbols at all other positions should be between 13,0 dBm and 14,0 dBm over the frequency band from 100 Hz to 80 kHz.

A.12.4 Power spectral density

The upper bound of the power spectral density of the transmitted signal shall be as shown in figure A.12. Measurements to verify compliance with this requirement are to use a noise power bandwidth of 1,0 kHz.

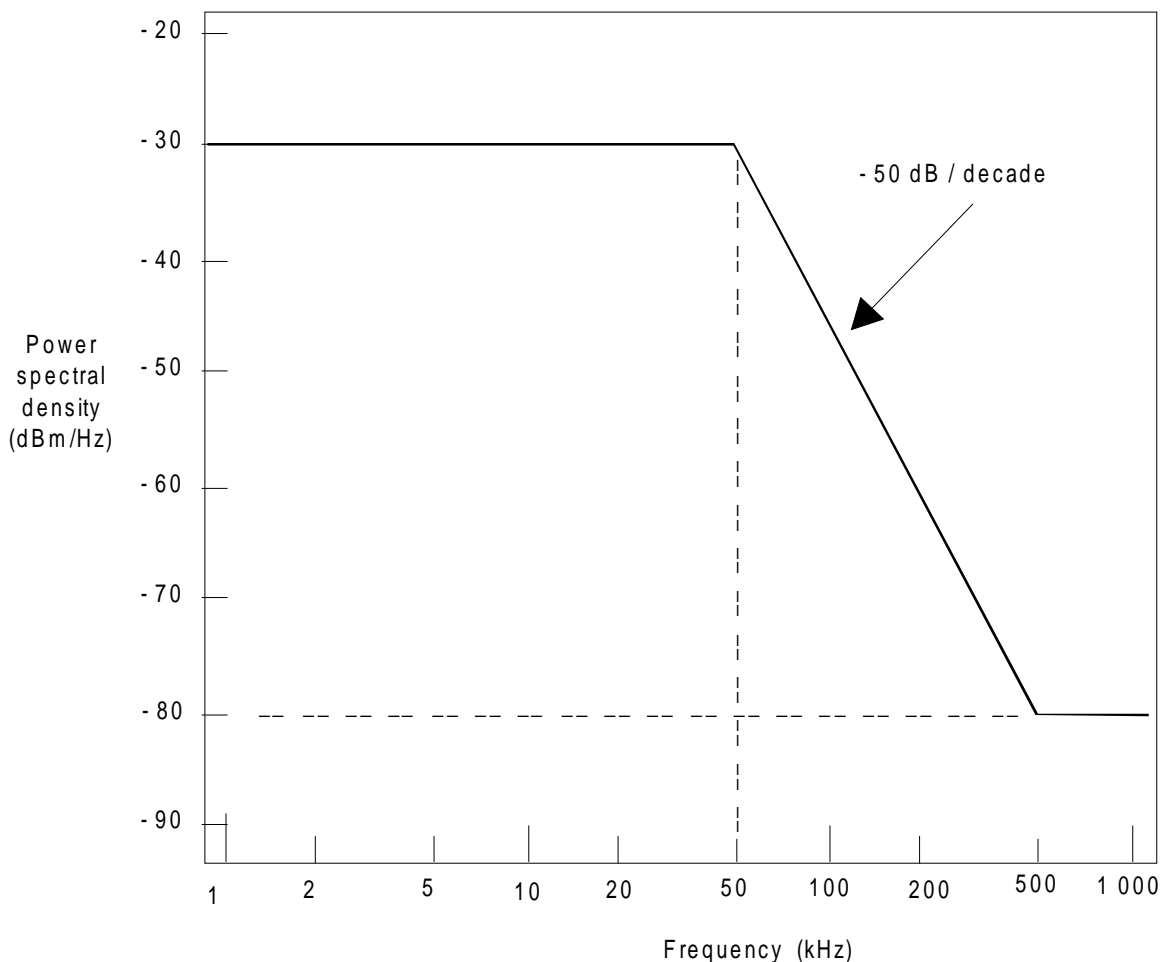

Figure A.12: Upper bound of power spectral density from NT1 and LT

A.12.5 Transmitter linearity

A.12.5.1 Requirements

This is a measure of the deviations from ideal pulse heights and the individual pulse non-linearity. The transmitted and received signals shall have sufficient linearity so that the residual rms non-linearity is at least 36 dB below the rms signal at the interface.

A.12.5.2 Linearity test method

With the transceiver (LT or NT1) terminated in a 135 Ω resistance through zero-length loop, and driven by an arbitrary binary sequence, the voltage appearing across the resistance is filtered (anti-alias), sampled and converted to digital form (V_{out}) with a precision of not less than 12 bits (see figure A.13). These samples are compared with the output of an adjustable, linear filter, the input of which is the scrambled, framed, and linearly encoded transmitter input. The signals at the subtractor may both be in digital form, or they may both be in analog form.

The linear digital filter input ("quaternary input data" in figure A.13) can be considered a linearity standard. It may be produced from the transmitter output by an errorless receiver (with no descrambler), or from the scrambled transmitter input data if it is available. If the samples input to the adjustable filter are available in digital form, no additional Analog to Digital (A/D) converter is required. Whether analog or digital, these samples are required to be in the ratio 3:1:-1:-3, to an accuracy of at least 12 bits.

The sampling rate of the samplers and filters may be higher than the symbol rate, and generally will be several times the symbol rate for good accuracy. Alternatively, the sample rate may be at the symbol rate, but the rms values are obtained by averaging over all sample phases relative to the transmitter signal.

Because the anti-alias filter, sampler, and A/D converter operating on the transmitter output may introduce a loss or gain, proper calibration requires determining $\langle V_{out}^2 \rangle$ at the filter output, as shown in figure A.13, rather than the mean-squared value of the transmitter output itself.

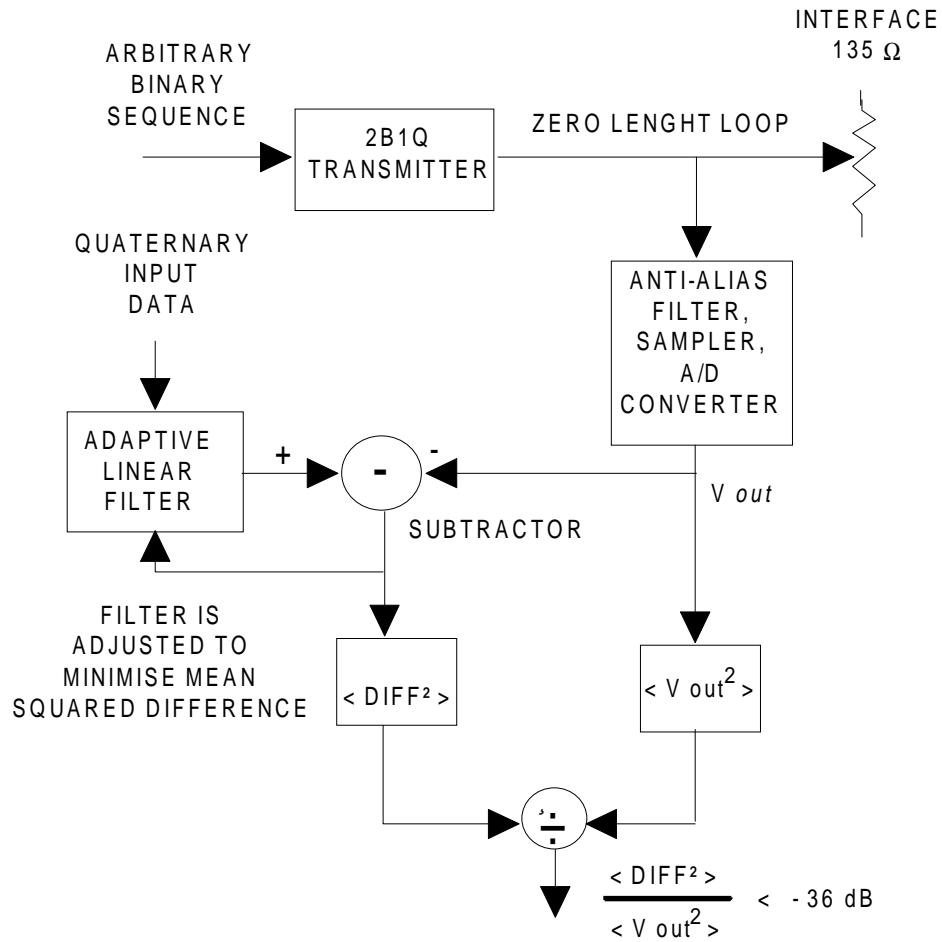

Figure A.13: Measurement of transmitter linearity

A.13 Transmitter/receiver termination

A.13.1 Impedance

The nominal driving point impedance at the interface toward the NT1, REG and LT shall be 135 Ω .

A.13.2 Return loss

The return loss with respect to 135 Ω , over a frequency band from 1 kHz to 200 kHz, shall be as shown in figure A.14.

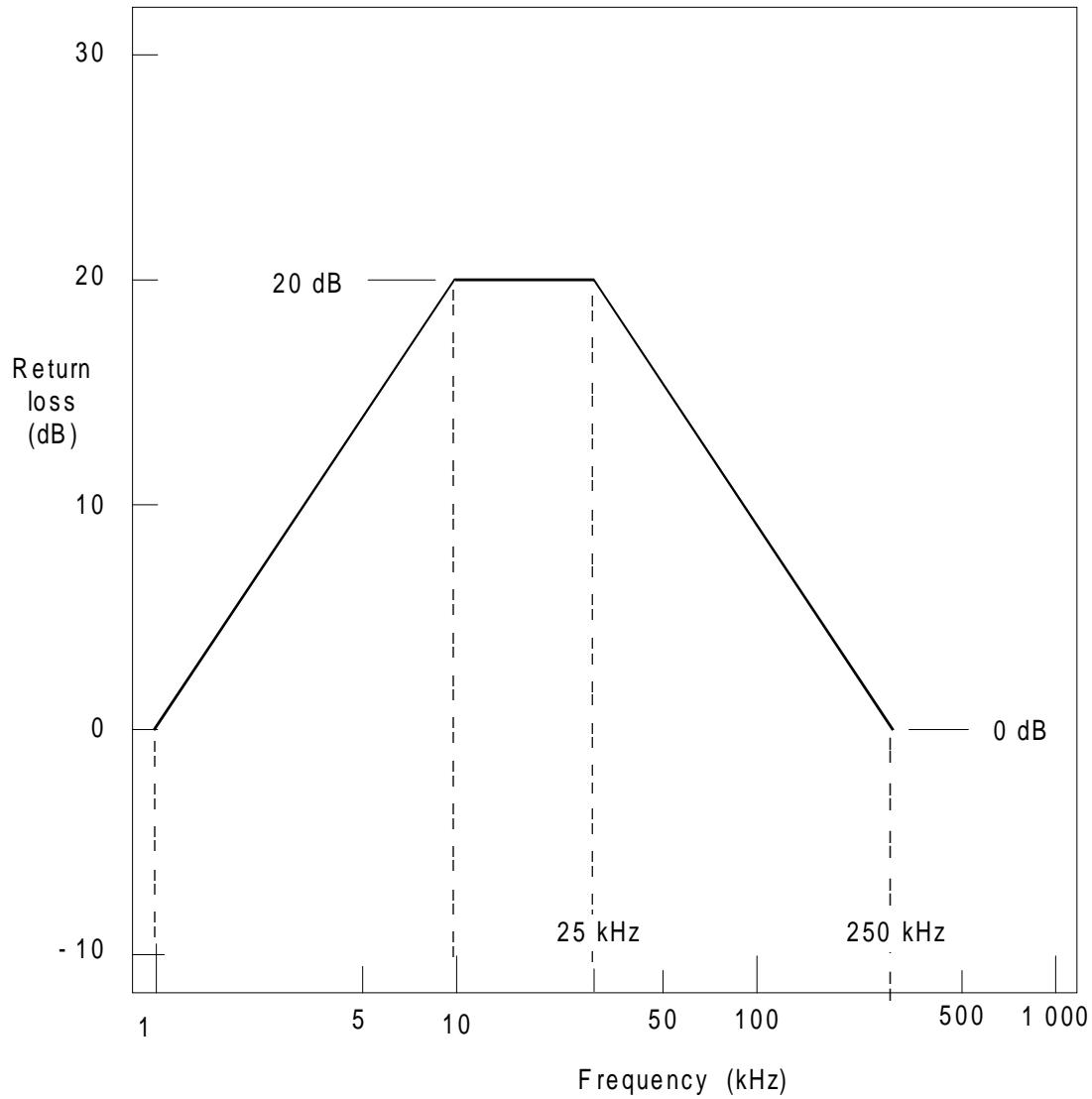

Figure A.14: Minimum return loss

A.13.3 Unbalance about earth

A.13.3.1 Longitudinal conversion loss

The Longitudinal Conversion Loss (LCL) is defined in subclause 4.3 and figure 9.

Figure A.15 gives the requirements for LCL.

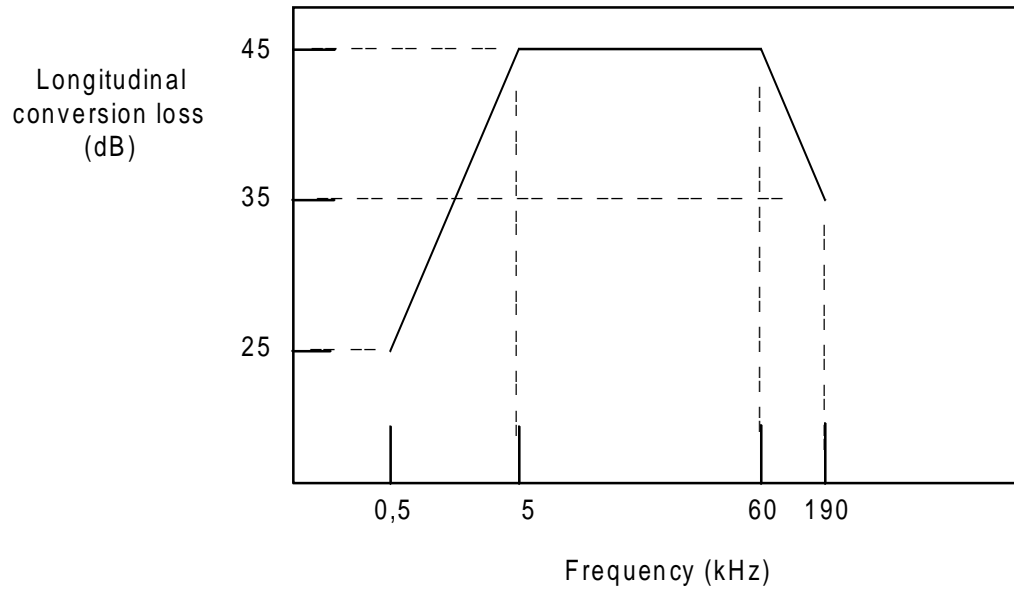

Figure A.15: Minimum longitudinal conversion loss requirement

Appendix I (to Annex A): Extension functions of the system using 2B1Q line code

I-1 Introduction

The optional use of the functions as described in this Appendix is for information. The functions are defined in the ETR.

I-2 NT1 Power status bits

The power status bits shall be the M_4 bits in the second and third basic frames of multiframes transmitted by the NT1 (see figure A.3). The use of this function is optional. When used, the power status bits shall be used as defined in table I-1 (see subclause A.8.3.2.4). If these bits are not used they shall be set to ONE in SN3.

Table I-1: Power status bit assignments and messages

NT1 status	PS ₁ PS ₂ binary values	Definition
All Power Normal	11	Primary and back-up battery (if provided) power supplies are both normal. Normal power at T reference point, if provided.
Secondary Power Out	10	Primary power is normal, but the back-up battery (if provided) is marginal, unavailable, or has failed. Normal power at T reference point, if provided.
Primary Power Out	01	Primary power is marginal or has failed. Back-up battery (if provided) is normal. Voltage at T reference point (if provided) is less than 34 V or reversed.
Dying Gasp	00	Both primary power and back-up battery (if provided) are marginal or have failed. Voltage at T reference point (if provided) is less than 34 V or reversed. The NT1 may shortly cease normal operation.
<p>NOTE: The coding scheme defined in this table allows several alternatives of implementation of power status provision in the NT1. Additionally, the application and the definition of the specific parameters may depend on the national network operator's maintenance strategy. The specific application and definition of parameters is, therefore, to be provided by the network operator on the basis of the general coding rule provided.</p>		

I-3 NTM bit

The NT1 test mode indicator bit shall be the M_4 bit in the fourth basic frame of multiframes transmitted by the NT1 to the network (see figure A.3). The use of this function is optional. The NT1 is considered to be in a test mode when the D-channel or either one of the B-channels are involved in a customer locally-initiated maintenance action. While in test mode, the NT1 may be unavailable for service or the NT1 may be unable to perform actions requested by EOC messages. If the function is used, the bit shall be a ONE to indicate normal operation and a ZERO to indicate test mode. If the function is not used, the bit shall be set to ONE in SN3 (see subclause A.8.3.2.5).

I-4 CSO bit

The Cold-Start-Only (CSO) bit is the M_4 bit in the fifth frame of the multiframe transmitted by a NT1. The use of this function is optional. It may be used to indicate the start-up capabilities of the NT1 transceiver. If the NT1 has a cold-start-only transceiver, as defined in Clause A.10 (5), this bit is set to ONE. Otherwise, this bit shall be set to ZERO in SN3 (see subclause A.8.3.2.6).

I-5 UOA bit

The DLL-Only-Activation (UOA) bit shall be the M_4 bit in the seventh basic frame of the multiframes transmitted by a LT. The use of this function is optional. It shall be used to request the NT1 to activate or deactivate the interface at the T reference point (if present). If the interface at the T reference point is to be activated, this bit may be set to ONE. Otherwise, this bit may be set to ZERO. If the function is not used, the bit shall be set to ONE in SL2 and SL3 (see subclause A.8.3.2.7). Tables I.2 and I.3 are state transition tables showing the use of the UOA bit in activation of the DLL without activating the interface at the T reference point. Figures I.3 through I.7 illustrate these examples further.

I-6 SAI bit

The S/T-interface-Activity-Indicator (SAI) bit shall be the M_4 bit in the seventh basic frame of the multiframes transmitted by a NT1. The use of this function is optional. It may be used to indicate to the network when there is activity at the interface at the T reference point. If there is activity (INFO 1 or INFO 3) at the interface at the T reference point, this bit may be set to ONE. Otherwise it may be set to ZERO. If this function is not used, the bit shall be set to ONE in SN3 (see subclause A.8.3.2.8). This bit may be used in conjunction with DLL-only-activation; see Clause I-5.

I-7 AIB

The Alarm Indicator Bit (AIB) shall be the M_4 bit in the eighth basic frame of the multiframes transmitted by the network toward the NT1. The use of this function is optional. When the transmission path for D-channel, B_1 -channel, and B_2 -channel has been established all the way to the local exchange, a ONE may be forwarded to the NT1. Failure or interruption of an intermediate transmission system which transports the D-channel, B_1 -channel, and B_2 -channel shall result in forwarding ZERO to the NT1. Such failures may include loss of signal, loss of frame synchronisation/carrier link or basic access DLL), and transmission terminal failure. Intermediate transmission interruptions may include loopbacks at intermediate points or absence of provisioning of an intermediate transmission system. If this function is not used, the bit shall be set to ONE in SN3 (see subclause A.8.3.2.9).

Table I.2: Activation/deactivation: NT finite state matrix (DSL-only turn-on option) : an example

Event V	State name	Power off	Full reset	Alerting	EC Training (optional)	EC converged	FW sync	IFW sync	IFW sync CALL	Pending active	Active	UOA	S/T deactivation	UOA & TE CALL	Pending deactivation	Tear down	Receive reset
	State code (figure A.6 event)	NT0	NT1 (T0)	NT2	NT3 (T1)	NT4 (T2)	NT5 (T5)	NT6(a) (T6)	NT6 (T6)	NT7	NT8	NT8(a)	NT8(b)	NT8(c)	NT9	NT10	NT12
	Signal --> LT	SN0	SN0	TN	SN1	SN0	SN2	SN3 act=0 sal=1 or 0	SN3 act=0 sal=1 or 0	SN3 act=1 sal=1	SN3 act=1 sal=1	SN3 act=0 sal=0	SN3 act=0 sal=0	SN3 act=0 sal=1	SN3 (NOTE 8)	SN0	SN0
	Signal --> TE	INFO 0	INFO 0	INFO 0	INFO 0	INFO 0	INFO 0	INFO 0	INFO 0	INFO 2	INFO 2	INFO 4	INFO 0	INFO 0	INFO 0	INFO 0	INFO 0
Power ON	ST.M4 NT2	-	-	-	-	-	-	-	-	-	-	-	-	-	-	-	-
Loss of power	-	NT0	NT0	NT0	NT0	NT0	NT0	NT0	NT0	NT0	NT0	NT0	NT0	NT0	NT0	NT0	NT0
Received new S/T INFO 1 signal (NOTE 2)	/	ST.M4 NT2 (NOTE 12)	-	-	-	-	-	-	/	/	NT8(c)	NT8(c)	-	-	-	-	-
Received INFO 3 signal (uoa=1, act=0, dea=1) (NOTE 2)	/	/	/	/	/	/	/	NT7	-	-	/	-	/	-	-	-	-
Received INFO 0 or S/T Loss of Sync (NOTE 2)	/	-	-	-	-	-	-	-	NT6	NT6	/	NT8(a)	/	-	-	-	-
End of tone TN (9 ms)	/	/	NT3 or NT4	/	/	/	/	/	/	/	/	/	/	/	/	/	/
Received tone TL	/	ST.M4 NT2	-	/	/	/	/	/	/	/	/	/	/	/	/	/	STP.M6 NT2
Echo canceller converged	/	-	-	NT4	-	-	-	-	-	-	-	-	-	-	-	-	-
FW sync and detect SL2	/	/	/	/	NT5	-	-	-	-	-	-	-	-	-	-	-	/
IFW sync (SL2)	/	/	/	/	/	STP.M4 NT6(a)	-	-	-	-	-	-	-	-	-	-	/

(continued)

**Table I.2 (concluded): Activation/deactivation: NT finite state matrix (DSL-only turn-on option) :
an example**

Event V	State name	Power off	Full reset	Alerting	EC Training (optional)	EC converged	FW sync	IFW sync	IFW sync CALL	Pending active	Active	UOA	S/T deactivation	UOA & TE CALL	Pending deactivation	Tear down	Receive reset
	State code (figure A.6 event)	NT0	NT1 (T0)	NT2	NT3 (T1)	NT4 (T2)	NT5 (T5)	NT6(a) (T6)	NT6 (T6)	NT7	NT8	NT8(a)	NT8(b)	NT8(c)	NT9	NT10	NT12
	Signal --> LT	SN0	SN0	TN	SN1	SN0	SN2	SN3 act=0 sal=1 or 0	SN3 act=0 sal=1 or 0	SN3 act=1 sal=1	SN3 act=1 sal=1	SN3 act=0 sal=0	SN3 act=0 sal=0	SN3 act=0 sal=1	SN3 (NOTE 8)	SN0	SN0
	Signal --> TE	INFO 0	INFO 0	INFO 0	INFO 0	INFO 0	INFO 0	INFO 0	INFO 2	INFO 2	INFO 4	INFO 0	INFO 0	INFO 0		INFO 0	INFO 0
Received (SL2 or SL3) dea=0 (NOTE 6)	/	/	/	/	/	/	/	NT9	NT9	NT9	NT9	NT9	NT9	NT9	-	-	/
Received (SL2 or SL3) uoa=0 and dea=1	/	/	/	/	/	/	/	NT8(a) or NT8(c)	NT8(a) or NT8(c)	NT8(b)	NT8(b)	-	-	-	Previous state (NOTE 13)	-	/
Received (SL2 or SL3) uoa=1, act=0 and dea=1	/	/	/	/	/	/	/	NT6	-	-	NT7	NT6	-	NT6	Previous state (NOTE 13)	-	/
Received (SL3) uoa=1, act=1 and dea=1	/	/	/	/	/	/	/	-	-	NT8	-	-	-	-	Previous state (NOTE 13)	-	/
Loss of synchronisation (> 480 ms)	/	/	/	/	/	/	/	NT10	NT10	NT10	NT10	NT10	NT10	NT10	NT10	-	-
Loss of signal (> 480 ms)	/	/	/	/	/	STP.M4 NT1 (NOTE 14)	-	ST.M6 NT12	ST.M6 NT12	ST.M6 NT12	ST.M6 NT12	ST.M6 NT12	ST.M6 NT12	ST.M6 NT12	/	/	-
Expiry of timer M4 (15 seconds)	/	/	/	/	NT10	NT10	NT10	/	/	/	/	/	/	/	/	/	-
Loss of signal < 40 ms	/	/	/	/	/	-	-	-	-	-	-	-	-	-	ST.M6 NT12	ST.M6 NT12	/
Expiry of timer M6 (40 ms)	/	/	/	/	/	/	/	/	/	/	/	/	/	/	/	/	NT1

Table I.3: Activation/deactivation: LT finite state matrix (DSL-only turn-on option) :
an example

Event V	State name	Power off	Full reset	Alerting	Awake	EC Training (optional)	EC converged CALL	FW sync CALL	IFW sync CALL	Active	EC converged UOA	FW sync UOA	U active	Deactivation S/T	Deactivation alerting	Tear down	Pending deactivation	Receive reset
	State code (figure A.6 event)	LT0	LT1 (T0)	LT2	LT3 (T1)	LT4 (T3)	LT5 (T4)	LT6	LT7 (T7)	LT8	LT5(a) (T4)	LT6(a)	IT8(a)	LT7(a)	LT9	LT10	LT11	LT12
	Signal --> NT	SL0	SL0	TL	SL0	SL1	SL2 dea=1 act=0 uoa=1	SL2 dea=1 act=0 uoa=1	SL3 dea=1 act=0 uoa=1	SL3 dea=1 act=1 uoa=1	SL2 dea=1 act=0 uoa=0	SL2 dea=1 act=0 uoa=0	SL3 dea=1 act=0 uoa=0	SL3 dea=1 act=0 uoa=0	SL3 dea=1 act=0 uoa=0	SL3 dea=0 act=0	SL0	SL0
Power ON		LT1	-	-	-	-	-	-	-	-	-	-	-	-	-	-	-	-
Loss of power (NOTE 1)		-	LT0 FE7	LT0 FE7	LT0 FE7	LT0 FE7	LT0 FE7	LT0 FE7	LT0 FE7	LT0 FE7	LT0 FE7	LT0 FE7	LT0 FE7	LT0 FE7	LT0 FE7	LT0 FE7	LT0 FE7	LT0 FE7
Activation request (FE1) (NOTE 1)		-	ST.M5 LT2 FE2	-	-	-	-	-	-	-	LT5	LT6	LT7	LT7	-	-	-	-
U-only Turn-on request (FE11) (NOTE 1)		-	ST.M5 LT2	-	-	-	LT5(a)	LT6(a)	LT7(a)	LT7(a)	-	-	-	-	-	-	-	-
Deactivation request (FE5) (NOTES 1 and 9)		-	-	-	-	-	-	-	LT9	LT9	-	-	LT9	LT9	-	-	-	-
End of tone TL (3 ms)		/	/	LT3	/	/	/	/	/	/	/	/	/	/	/	/	/	/
Received tone TN		/	ST.M5 LT3 FE2	-	-	/	/	/	/	/	/	/	/	/	/	/	/	ST.M5 STP.M7 LT3 FE2
Loss of signal energy (TN or SN1)		/	-	-	LT4, LT5 or LT5(a)	-	/	/	/	/	/	/	/	/	/	/	/	/
Echo canceller converged and FE11 (NOTE 1)		/	-	-	-	LT5(a)	-	-	-	-	-	-	-	-	-	-	-	-
Echo canceller converged and FE1 (NOTE 1)		/	-	-	-	LT5	-	-	-	-	-	-	-	-	-	-	-	-

(continued)

Table I.3 (concluded): Activation/deactivation: LT finite state matrix (DSL-only turn-on option) : an example

Event V	State name	Power off	Full reset	Alerting	Awake	EC Training (optional)	EC converged CALL	FW sync CALL	IFW sync CALL	Active	EC converged UOA	FW sync UOA	U active	Deactivation S/T	Deactivation alerting	Tear down	Pending deactivation	Receive reset
	State code (figure A.6 event)	LT0	LT1 (T0)	LT2	LT3 (T1)	LT4 (T3)	LT5 (T4)	LT6	LT7 (T7)	LT8	LT5(a) (T4)	LT6(a)	LT8(a)	LT7(a)	LT9	LT10	LT11	LT12
	Signal --> NT	SL0	SL0	TL	SL0	SL1	SL2 dea=1 act=0 uoa=1	SL2 dea=1 act=0 uoa=1	SL3 dea=1 act=0 uoa=1	SL3 dea=1 act=1 uoa=1	SL2 dea=1 act=0 uoa=0	SL2 dea=1 act=0 uoa=0	SL3 dea=1 act=0 uoa=0	SL3 dea=1 act=0 uoa=0	SL3 dea=1 act=0 uoa=0	SL3 dea=0 act=0	SL0	SL0
FW sync (SN2 or SN3)	/	/	/	/	/	/	LT6	-	-	-	LT6(a)	-	-	-	-	-	-	-
IFW sync (SN3) (NOTE 1)	/	/	/	/	/	/	/	STP.M5 LT7 FE3	-	-	/	STP.M5 LT8(a) FE3	-	-	-	-	-	-
Received (SN3) act=0 (NOTE 1)	/	/	/	/	/	/	/	/	-	LT7 FE12	/	/	-	LT8(a) FE3	-	-	-	-
Received (SN3) act=1 (NOTE 1)	/	/	/	/	/	/	/	/	LT8 FE4	-	/	/	/	-	-	-	-	-
Received (SN3) sal=1 (NOTE 1)	/	/	/	/	/	/	/	/	-	-	/	/	LT7 FE2 (NOTE 15)	-	-	-	-	-
Loss of synchronisation (> 480 ms) (NOTE 1)	/	/	/	/	/	/	/	/	LT10 FE7	LT10 FE7	/	/	LT10 FE7	LT10 FE7	LT10 FE7	-	-	-
Loss of signal (> 480 S) (NOTE 1)	/	/	/	LT1	/	/	-	-	ST.M7 LT12 FE7	ST.M7 LT12 FE7	-	-	ST.M7 LT12 FE7	ST.M7 LT12 FE7	ST.M7 LT12 FE7	-	-	-
End of last super frame with dea=0 (NOTE 10)	/	/	/	/	/	/	/	/	/	/	/	/	/	/	LT11	/	/	/
Expiry of timer M5 (15 seconds) (NOTE 1)	/	/	/	LT10 FE7	LT10 FE7	LT10 FE7	LT10 FE7	LT10 FE7	/	/	LT10 FE7	LT10 FE7	/	/	/	/	/	/
Absence of signal < 40 ms (NOTE 1)	/	-	/	/	/	/	-	-	-	-	-	-	-	-	-	ST.M7 LT12	LT1 FE6	-
Expiry of timer M7 (40 ms) (NOTE 1)	/	/	/	/	/	/	/	/	/	/	/	/	/	/	/	/	/	LT1 FE6

Table I.4: Symbols, abbreviations and NOTES for tables I.2 and I.3

Symbols and abbreviations:	
"_"	= No change, no action.
"/"	= Impossible or prohibited situation under normal circumstances.
"FE1"	= Activate Access Request (AR) (NOTE 1).
"FE2"	= Access Activation Initiated (NOTE 1).
"FE3"	= Line Transceivers Activated (NOTE 1).
"FE4"	= Access Activated or Loopback Operated (AI) (NOTE 1).
"FE5"	= Deactivate Access Request (NOTE 1).
"FE6"	= Access or Loopback Deactivated (DI) (NOTE 1).
"FE7"	= LOS/LFA in Line Transceivers - (including Loss of Power at NT1) (NOTE 1).
"FE8"	= Activate Loopback 2 (NOTE 1).
"FE9"	= Activate Loopback 1 (at LT towards network) (NOTE 1).
"FE10"	= Activate Loopback 1a (at Regenerator towards network) (NOTE 1).
"FE11"	= Partial Activation Request (UOA) (see subclause A.8.3.2.7) (NOTE 1).
"FE12"	= Report LOS/LFA at T reference point (see subclause A.8.3.2.8).
"FE13"	= Deactivate the interface at T reference point whilst keeping the Access Digital Section activated (NOTE 1).
"NTn"	= Go to state "NTn".
"LTn"	= Go to state "LTn".
"ST.Mn"	= Start timer Mn.
"STP.Mn"	= Stop timer Mn.
"SLn,SNn"	= Signals defined in figures A.6 and A.7 (SL0, SN0 = no signal).
"Tn"	= Events defined in figures A.6 and A.7.

(continued)

Table I.4 (concluded): Symbols, abbreviations and NOTES for tables I.2 and I.3

NOTES:

- NOTE 1: The function elements are also defined in ETS 300 297 [8], subclause 8.4.3.
- NOTE 2: INFO signals at the T reference point are defined in ETS 300 012 [9], subclause A.6.2.2.
- NOTE 3: Deleted.
- NOTE 4: Deleted.
- NOTE 5: Deleted.
- NOTE 6: Cold-start-only NTs may ignore this event.
- NOTE 7: Deleted.
- NOTE 8: The signals output in this state remain unchanged from signals output during the preceding state (for example, ACT=0 if state NT6 preceded, or ACT=1 if states NT7 or NT8 preceded). The INFOS also remain unchanged.
- NOTE 9: This event is only the first step of a sequence leading to deactivation. After transmitting DEA=0 for a short interval (see NOTE 10), the LT sends SL0 to deactivate the NT.
- NOTE 10: This event occurs as a result of FE5 (see NOTE 9) after entering state LT9 and transmitting at least three super frames with DEA=0 (see subclause A.10.1.5).
- NOTE 11: Deleted.
- NOTE 12: When INFO 1 remains continuous after the NT fails to bring up the network side and returns to state NT1, the NT does not go again into state NT2 unless a new transition from INFO 0 to INFO 1 is received (see Clause A.10 (10) and ETS 300 012 [9]).
- NOTE 13: The transceiver should return to the state from which it entered state NT9, unless the UOA or ACT bit(s) have changed.
- NOTE 14: The transitions resulting from this event, to either full reset (NT1) or receive reset (NT12), are controlled by the requirements in subclause A.10.2.
- NOTE 15: The network is permitted to choose "No action" rather than sending FE1 and transferring to state LT7. For example, when the access link is undergoing maintenance, "No action" is an appropriate response.

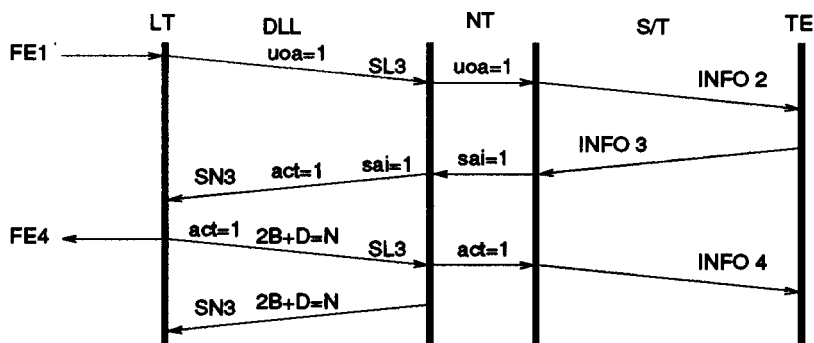

NOTE 1: Receipt of $INFO3$ and $SL3$ at the NT can theoretically occur in either order.

NOTE 2: For symbols and abbreviations see table I.4.

Figure I.1: Change from DSL-only to total activation initiated by the exchange (FE1)

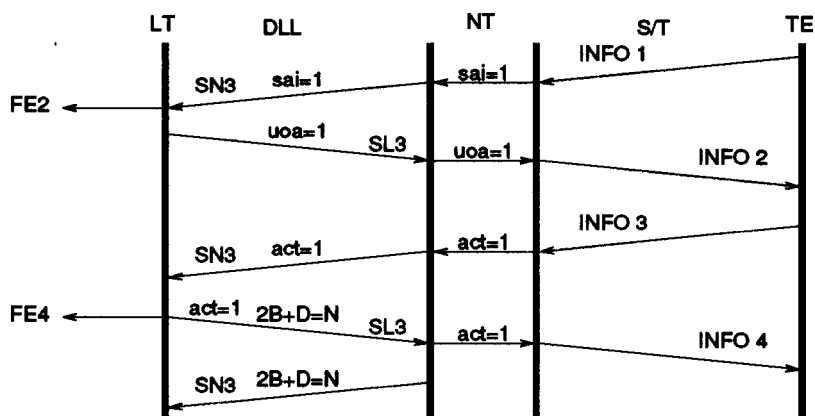

NOTE 1: Receipt of $INFO3$ and $SL3$ at the NT can theoretically occur in either order.

NOTE 2: For symbols and abbreviations see table I.4.

Figure I.2: Change from DSL-only to total activation initiated by terminal equipment ($INFO\ 1$)

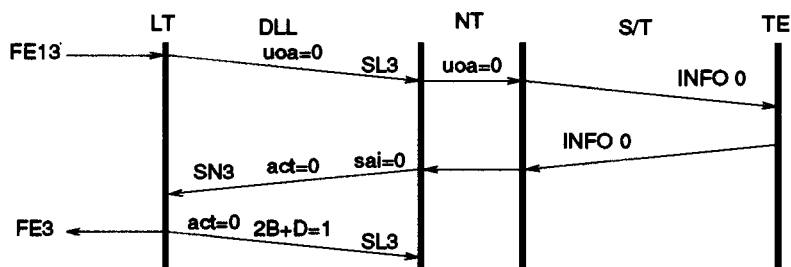

NOTE: For symbols and abbreviations see table I.4.

Figure I.3: Change to DSL-only from total activation initiated by the exchange (FE13)

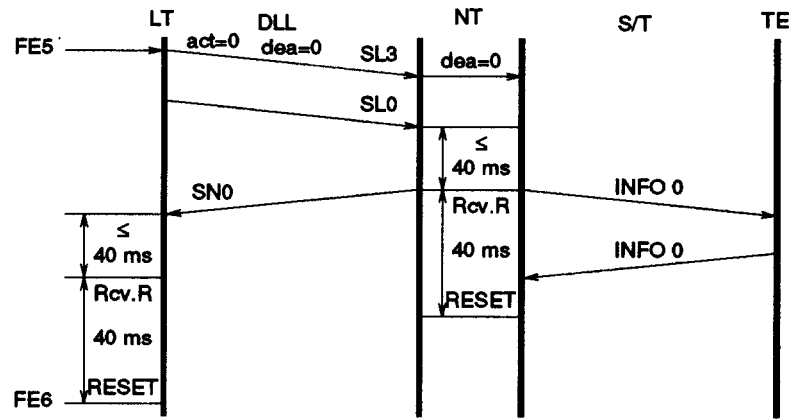

NOTE: For symbols and abbreviations see table I.4.

Figure I.4: Total deactivation process

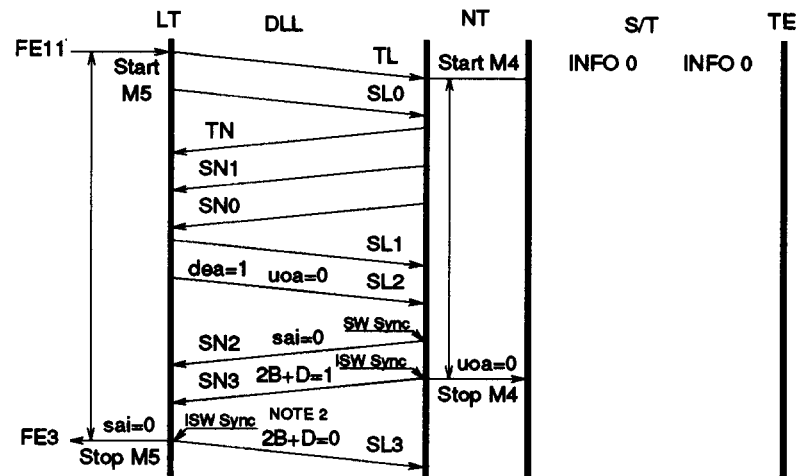

NOTE 1: For symbols and abbreviations see table I.4.

NOTE 2: Except to perform a loopback, 2B+D bits shall remain in the previous state (SN2 or SL2) until both act bits indicate full transparency of B-channels and D-channels (see figure A.7). Transparency required to perform loopbacks is independent of the act bits.

Figure I.5: DSL-only turn-on process initiated by the exchange from reset (FE11)

Appendix II (to Annex A): Discussion of EOC addressing

Figure II-1 shows a possible worst-case architecture for supporting ISDN basic access. In such extended configurations, the Digital Subscriber Line (DSL) provided by the switch connects to intermediate transmission equipment instead of connecting directly to a NT. There may be additional transmission elements at more distant points in the configuration before eventually terminating at the NT.

Each transmission element indicated by **n** in Clause II-1, with **n** equal to 1 through 5, may need to be given an EOC address. This allows the switch to send layer-1 maintenance commands to each of these elements. The address for such transmission elements is assigned in a relative fashion with respect to the switch, such that the first element from the switch is treated by the network as EOC address 1, the next as EOC address 2, and so on. The NT is always addressed as 0.

II-1 Addresses 1 through 6 (intermediate elements)

For the above addressing scheme, the intermediate transmission element have EOC addresses in the range of 1 to 6. Intermediate transmission elements will react to addresses 1 through 6 as follows:

- a) direction towards customer (network to NT):
 - 1) if address in range of 2 to 6, decrement address and pass message on;
 - 2) if address equals 1, comply with received message and send proper EOC response frame back toward the network. The response frame will be written over the response frame from the NT. Pass the EOC frame on with the broadcast address and the message changed to hold state;
- b) direction towards network (NT to network):
 - 1) if address in range 1 to 5, increment address and pass message on.

NOTE: For the addressing mechanism described in this appendix, the order of the address bits in the EOC address field is important. In figure A.3 the M_1 , M_2 and M_3 bits in the first frame of the multi-frame are the eoc address, EOC_{a1} , EOC_{a2} and EOC_{a3} , respectively. In this address field, EOC_{a3} is the least significant bit.

II-2 Action of intermediate elements

The intermediate transmission elements will react to EOC addresses 0 and 7 (NT address and broadcast address, respectively) as follows:

- a) if address 0, address not changed and message passed on (both directions);
- b) if address 7, comply with received message, address not changed, and message passed on (both directions).

Therefore, all downstream units would comply with a message with a broadcast address; however, only the NT would respond with an acknowledgement. Intermediate units would relay the NT's acknowledgement to the network.

When EOC messages for internal ISDN network use activate operations functions identical to operations functions standardised at the NT, then the message codes for those messages should also be identical.

II-3 Action of NT

The NT will only comply with messages to addresses 0 and 7. When messages are received at the NT with addresses 1 through 6, the NT sends back an EOC frame with the hold state message and address 0. The proper action for the NT in every case is fully defined in subclause A.8.3.3.2.

II-4 Summary

The above addressing scheme for assigning EOC addresses to intermediate transmission elements of extended configurations allows maintenance functions to be performed at each element, simplifying circuit provisioning and minimizing network reconfiguration costs.

Figure II-1 shows an example of a loopback request for element No 3 and the value of the address field at different links in the circuit.

In using this addressing scheme, it is important for the network to be aware of the exact configuration. Otherwise, the network may fail to address elements that are present, or may attempt to address elements that are not present. In any case, by not having correct information about the configuration, the network may send and receive data or issue commands that have entirely different meaning or results than expected.

The network will become aware of the fact that it is addressing an intermediate element beyond the last intermediate element in the configuration, because the NT will reply with the 0 address and the hold state message. However, if the actual configuration has more elements than assumed by the network, none of the messages sent by the network to intermediate addresses will result in a reply with a 0 address.

The NT response to messages it receives, that are not addressed to it, provides a means of determining the correct configuration at any time. The determination is possible because the network receives EOC frames with the address 0 and the hold state message, when it addresses a nonexistent element. For example, the correct EOC configuration may be determined at any time by the network, sending the hold state message with EOC address first set to 1, and then set to successively higher addresses until address 0 is returned in three consecutive identical EOC frames. This procedure can eliminate confusion and assure accurate communication on the EOC channel in those cases when record errors would have led to confusion. If record errors are a problem, or changes of configuration are frequent, this procedure could be repeated often enough to assure valid results of EOC transactions.

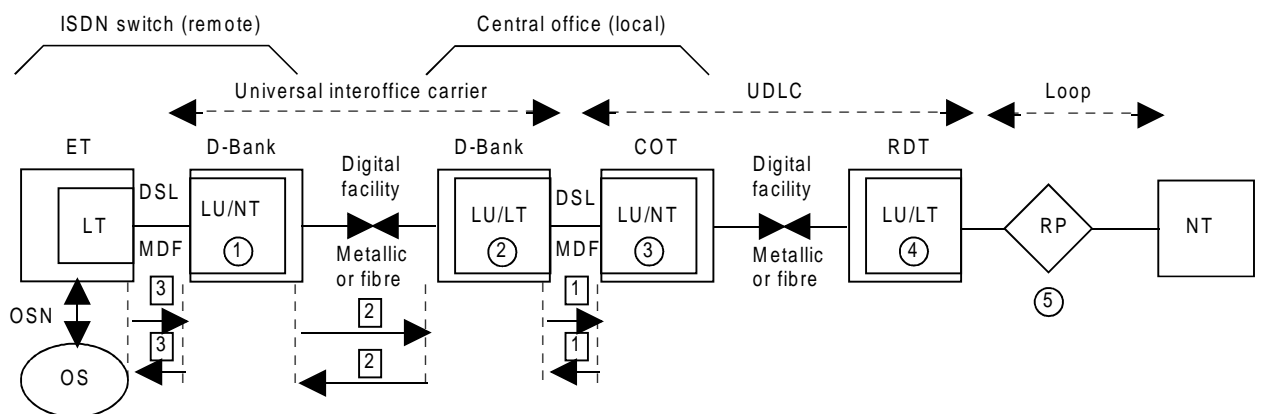

Symbols and abbreviations:

- | | |
|---|--|
| COT = Central office terminal | (n) = nth transmission element |
| DSL = Digital subscriber line | NT = Network termination |
| ET = Exchange termination | OS = Operations system |
| D-Bank = Digital channel bank/multiplexer | OSN = Operations system network (packet) |
| LT = Line termination | RDT = Remote digital terminal |
| LU/LT = Line unit/LT | RP = Loop repeater, network |
| LU/NT = Line unit/NT | UDLC = Universal digital loop carrier |
| MDF = Main distribution frame | [x] = Message with address x |

Figure II.1: Worst case ISDN basic access configuration

Annex B: Definition of a system using MMS 43 line code

B.1 Line code

For each direction of transmission the line code is a Modified Monitoring State (MMS) code mapping 4 bits into 3 ternary symbols with levels +, 0 or - (MMS 43). Details of the coding scheme are given in figure B.1. Note that the numbers in the columns for each of the 4 alphabets S1 . . . S4 give the numbers of the alphabet to be used for the coding of the next block of 4 bits. The bits and symbols on the left are those transmitted or received first.

	S1				S2				S3				S4			
0001	0	-	+	1	0	-	+	2	0	-	+	3	0	-	+	4
0111	-	0	+	1	-	0	+	2	-	0	+	3	-	0	+	4
0100	-	+	0	1	-	+	0	2	-	+	0	3	-	+	0	4
0010	+	-	0	1	+	-	0	2	+	-	0	3	+	-	0	4
1011	+	0	-	1	+	0	-	2	+	0	-	3	+	0	-	4
1110	0	+	-	1	0	+	-	2	0	+	-	3	0	+	-	4
1001	+	-	+	2	+	-	+	3	+	-	+	4	-	-	-	1
0011	0	0	+	2	0	0	+	3	0	0	+	4	-	-	0	2
1101	0	+	0	2	0	+	0	3	0	+	0	4	-	0	-	2
1000	+	0	0	2	+	0	0	3	+	0	0	4	0	-	-	2
0110	-	+	+	2	-	+	+	3	-	-	+	2	-	-	+	3
1010	+	+	-	2	+	+	-	3	+	-	-	2	+	-	-	3
1111	+	+	0	3	0	0	-	1	0	0	-	2	0	0	-	3
0000	+	0	+	3	0	-	0	1	0	-	0	2	0	-	0	3
0101	0	+	+	3	-	0	0	1	-	0	0	2	-	0	0	3
1100	+	+	+	4	-	+	-	1	-	+	-	2	-	+	-	3

NOTE: A received ternary block 000 is decoded as binary 0000.

Figure B.1: MMS 43-code

B.2 Symbol rate

The symbol rate is 120 kbaud.

B.2.1 Clock symbol requirements

B.2.1.1 NT1 free running clock accuracy

The tolerance of the free running NT1 clock is ± 100 ppm.

B.2.1.2 LT clock tolerance

The tolerance of the clock signal provided at the LT is ± 1 ppm.

B.3 Frame structure

Each frame contains a frame word, $2B + D$ data and the C_L channel. Multiframe are not used.

B.3.1 Frame length

The length of each frame is 120 ternary symbols corresponding to 1 ms. Each frame has 108 symbols (corresponding to 144 bits) carrying $2B + D$ data.

B.3.2 Symbol allocation LT to NT1

In the direction LT to NT1 the 120 symbols of each frame are used as follows:

- symbols 1 to 84: $2B + D$;
- symbol 85: C_L -channel;
- symbols 86 to 109: $2B + D$;
- symbols 110 to 120: frame word.

The channel allocation to the symbols 1 to 84 and 86 to 109 and the structure of the frame shall be as follows:

- 8 consecutive blocks of B_1+B_2+D , in total 144 bits, shall be scrambled and coded into 108 ternary symbols according to figure B.1. The first B_1 channel shall start with symbol number 1;
- after 84 of such coded symbols the C_L channel symbol shall be inserted, continued with the remaining 24 coded symbols. The 11 symbols forming the frame word shall be added after symbol 109.

B.3.3 Symbol allocation NT1 to LT

In the direction NT1 to LT, the frame structure is identical to that of the direction LT to NT1.

The frame transmitted by the NT1 is synchronised to that received from the LT.

B.4 Frame word

B.4.1 Frame word in direction LT to NT1

The frame word in the direction LT to NT1 is:

+ + + - - - + - + -

B.4.2 Frame word in direction NT1 to LT

The frame word in the direction NT1 to LT is:

- + - - + - - - + + +

B.5 Frame alignment procedure

The transmission system is considered to be synchronous if the frame word has been identified in the same position for 4 immediately succeeding frames. Loss of synchronisation is assumed if the detected frame position does not coincide with the expected position during 60 . . . 200 successive frames.

B.6 Multiframe

Not used.

B.7 Frame offset at NT1

On the line at the NT1 the frame word transmitted by the NT1 occurs 60 ± 1 symbols (0,5 ms) later than that received at the NT1 input, measured between the first symbols of each frame word.

B.8 C_L channel

B.8.1 Bit rate

The bit rate for the C_L channel (maintenance-channel) is 1 kbit/s.

B.8.2 Structure

No specific structure is defined for transparent messages.

B.8.3 Protocols and procedures

Transparent messages in the C_L channel use "0" and "-" polarity of the C_L symbol of the line signal. "0" and "+" polarity are used to request a loopback 2B + D in the NT1 or an intermediate repeater. Transparent use of the C_L channel may override these loopback commands.

Continuous "0" polarity is used as idle code.

The command/information channel protocol shall use "0" and "+" polarity codings.

Loopback commands are coded as follows:

| | |
|--|------------------|
| Loopback 1A activation (in regenerator): | continuous "+0"; |
| Loopback 2 activation (in NT1): | continuous "+"; |
| Loopback deactivation: | continuous "0". |

An activation or deactivation command is identified when 8 consecutive symbols according to the coding rule have been detected.

Transmission error detection and report:

- transmission errors shall be detected by monitoring frames received with one or more line code violations. An errored frame detected by the NT1 shall be reported back to the LT by setting one C_L symbol to "+" polarity.

Transparent channel:

- the transparent channel shall use "-" polarity for ZERO, "0" and "+" polarity shall be interpreted as ONE. "0" or "+" polarity shall be considered as idle code.

Messages of the transparent channel shall have priority.

B.9 Scrambling

In order to minimize correlation between incoming and transmitted symbols scrambling is used. Scrambling is applied only to the 2B+D channels.

The scrambling polynomial is different in both NT1 to LT and LT to NT1 directions:

- in direction LT to NT1: $1 \oplus x^{-5} \oplus x^{-23}$
- in direction NT1 to LT: $1 \oplus x^{-18} \oplus x^{-23}$,

where \oplus is the modulo two sum and x^{-k} is the scrambled data delayed by k symbol intervals.

B.10 Activation/deactivation

Activation/deactivation is provided to enable the use of a power down state, especially for applications where the NT1 is powered from the LT via the local line. Activation from the power state may be initiated from both ends using a 7,5 kHz burst signal. Collisions are handled through appropriate duration and repetition rate of these bursts.

The procedures on the line system support the procedures at reference point T for call control in accordance with ETS 300 012 [9] and the operation of loopbacks 1 (in the LT), 1A (in the regenerator) and 2 (in the NT1) in accordance with CCITT Recommendation I.603 [4]. The loopbacks are transparent.

Timer 1 and timer 2, as defined in ETS 300 012 [9], are located as follows:

- timer 1 in the ET layer 1 or the ET;
- timer 2 in the NT1.

The activation of the line system for maintenance purposes, e.g. error performance monitoring, is possible, even if no TE is connected to the interface at T reference point.

Transmission of INFO 2 on the interface of T reference point is initiated when the line system is synchronised in the direction LT to NT1.

B.10.1 Signals used for activation

To provide means to control/indicate progress during activation/deactivation across the local line the following signal elements are used:

- SIG 0 NT1 to LT and LT to NT1
 No signal.
- SIG 1W NT1 to LT
 Awake signal (7,5 kHz tone); signals the layer 1 entity in the local exchange that it has to enter the power-up state and provide for the activation of the line system and the interface at T reference point. This signal is also used as awake acknowledge on the receipt of SIG 2W.
- SIG 2W LT to NT1
 Awake signal (7,5 kHz tone); signals the NT1 that it has to enter the power-up state and prepare for synchronisation on an incoming signal from the LT. This signal is also used as awake acknowledge on the receipt of SIG 1W.
- SIG 1 NT1 to LT
 Signal which contains framing information and allows the synchronisation of the receiver in the LT. It informs the LT that the NT1 has synchronised on SIG 2.
- SIG 2 LT to NT1
 Signal which contains framing information and allows the synchronisation of the receiver in the NT1.
- SIG 1A NT1 to LT
 Signal similar to SIG 1 but without framing information.
- SIG 3 NT1 to LT
 Signal which contains framing information and allows the synchronisation of the receiver in the LT. It indicates to the ET that the interface at T reference point is synchronised in both directions of transmission (except in the case of loopback 2 and 1A).
- SIG 4H LT to NT1
 Signal which requires the NT1 to establish full layer 1 information transfer capability in both directions of transmission.
- SIG 4 LT to NT1
 Signal which contains framing information and operational data on B and D channels.
- SIG 5 NT1 to LT
 Signal which contains framing information and operational data on B and D channels.
- SIG 2-L2 LT to NT1
 Signal similar to SIG 2, but includes a loopback 2 request.
- SIG 4H-L2 LT to NT1
 Signal which requires the NT1 to operate loopback 2 and to establish layer 1 information transfer capability in the direction LT to TE (transparent loopback 2).
- SIG 4-L2 Signal similar to SIG 4, but includes a loopback 2 request.

All SIGs, except SIG 1W and SIG 2W, are continuous signals. The awake signals SIG 1W and SIG 2W are sent for a specified period of time only, but may be repeated if no acknowledgement is received. The repetition times are specified in a way to assure a proper interworking with the normal activation procedure.

The loopback requests are transmitted making use of the C_L channel. All other SIGs do not require the C_L channel.

The C_L channel is provided with all SIGs except SIG 0, SIG 1W, SIG 2W and SIG 1A.

B.10.2 Definition of internal timers

In the state transition tables and arrow diagrams the following internal timers are used.

- Tn1 = 13 ms: timer to supervise repetition of the awake signal SIG 2W from the LT.
- Tl1 = 7 ms: timer to supervise repetition of the awake signal SIG 1W from the NT1.
- Tl2 = 1 ms: timer which defines the duration of SIG 4H and SIG 4H-L2.
- Tl3 = 1 ms: timer which assures that, under non-failure conditions, the PH-AI is passed first in the TE and then in the LT/ET. This protects the first layer 2 frame (layer 3 - SETUP message) from the network side.
- Tl4 = 12 ms: timer used to start transmission of SIG 2 when loopback 1 is requested.
- Tl5 = 0,1 ... 1 s: timer to supervise the deactivation procedure (within ET).

B.10.3 Description of the activation procedure

In figure B.2 the activation/deactivation procedures are described for the non-failure situation.

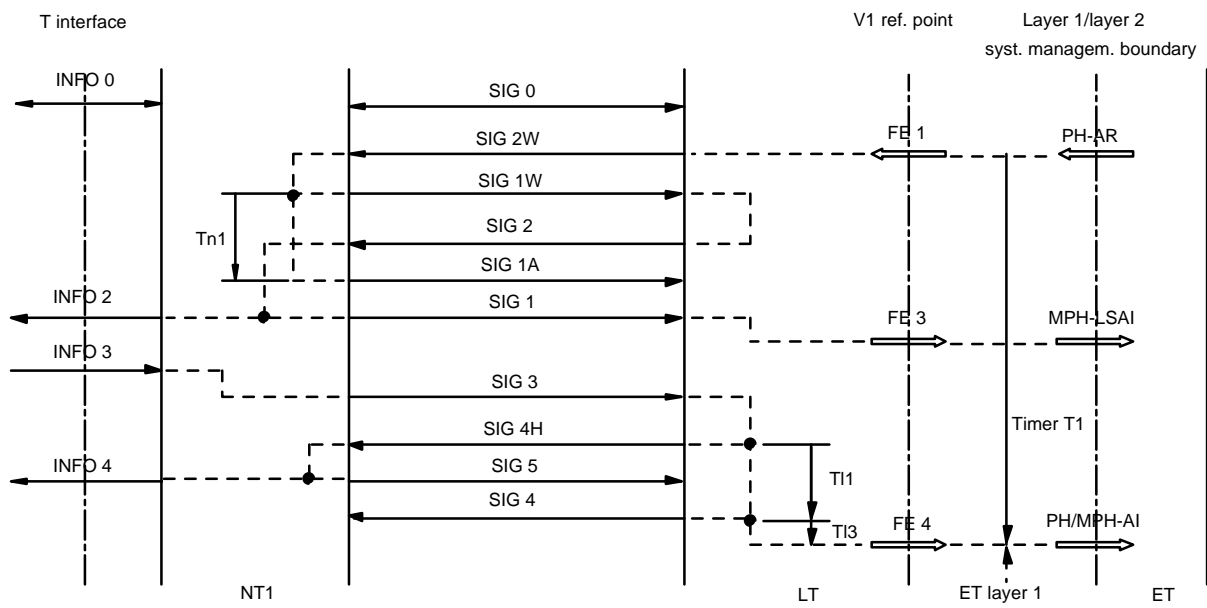

a) Activation from network side

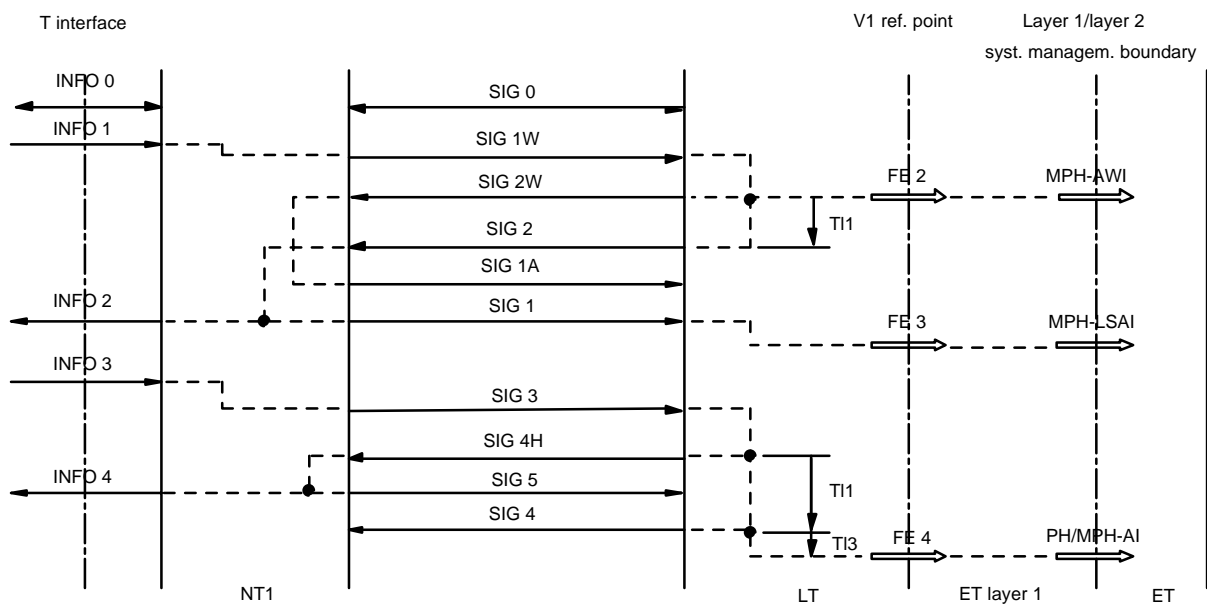

b) Activation from user side

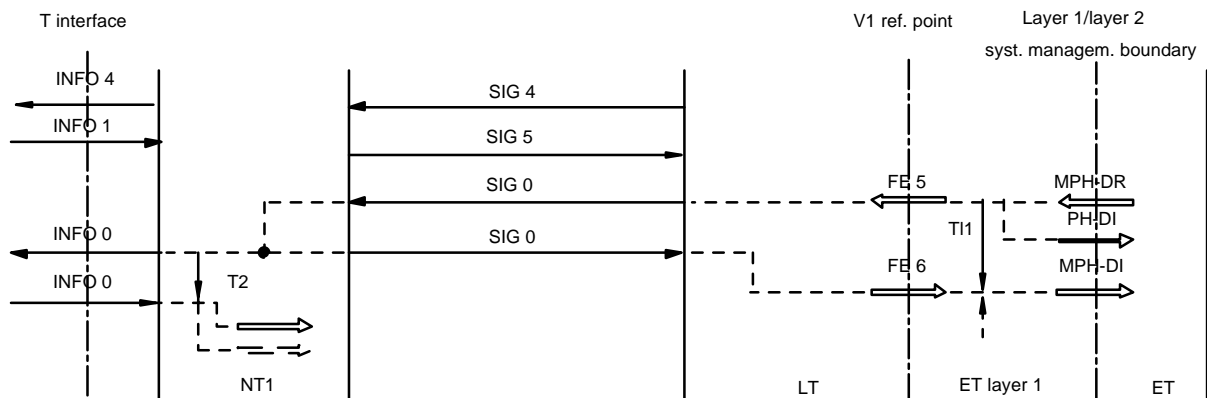

c) Deactivation

Figure B.2: Activation/deactivation procedures - arrow diagrams (non-failure situations)

Timer T1 (located in ET layer 1) and timer T2 (located in NT1) are as specified in ETS 300 012 [9]; the Function Elements (FEs) are defined in ETS 300 297 [8], subclause 8.4.3, and the primitives in ETS 300 297 [8], subclause A.3.2.

B.10.4 NT1 state transition table

The NT1 state transition table is described in table B.1. INFOs on the interface at T reference point are related to SIGs on the line system and vice versa.

Table B.1: NT1 state transition table

| State | NT1.1 | NT1.2 | NT1.3 | NT1.4 | NT1.5 | NT1.6 | NT1.7 | NT1.8 | NT1.9 | NT1.10 | NT2.1 | NT2.2 |
|----------------------------|-------------------|--------|--------|------------------|------------------|------------------|------------------|--------|------------------|------------------|------------------|------------------|
| transmit signal | INFO 0 | INFO 0 | INFO 0 | INFO 0 | INFO 2 | INFO 2 | INFO 4 | INFO 0 | INFO 2 | INFO X (NOTE 2) | INFO 2 | INFO 4 (NOTE 4) |
| receive signal | SIG 0 | SIG 1W | SIG 1W | SIG 1A | SIG 1 | SIG 3 | SIG 5 | SIG 0 | SIG 5 | SIG 0 (NOTE 3) | SIG 3 | SIG 5 (NOTE 5) |
| INFO 0 | - | - | - | - | - | - | NT 1.9 | NT 1.1 | - | - | - | - |
| INFO 1 | NT 1.2 | - | - | - | - | - | / | - | - | / | - | / |
| INFO 3 | / | / | / | / | NT 1.6 | - | - | - | NT 1.7 | / | - | - |
| SIG 0 | - | - | - | ST.T2;
NT 1.8 | ST.T2;
NT 1.8 | ST.T2;
NT 1.8 | ST.T2;
NT 1.8 | - | ST.T2;
NT 1.8 | ST.T2;
NT 1.8 | ST.T2;
NT 1.8 | ST.T2;
NT 1.8 |
| SIG 2W | ST.Tn1;
NT 1.3 | NT 1.4 | / | / | / | / | / | - | / | / | / | / |
| SIG 2 | / | - | - | NT 1.5 | - | - | / | / | / | / | NT 1.6
or - | / |
| SIG 4H | / | / | / | / | / | NT 1.7 | - | / | / | / | NT 1.7 | / |
| SIG 4 | / | / | / | / | / | / | - | / | - | - | / | NT 1.7 |
| Exp. T2 (NOTE 1) | - | - | - | - | - | - | - | NT 1.1 | - | - | - | - |
| Lost framing T interface | / | / | / | / | / | - | NT 1.9 | - | - | - | / | / |
| Lost framing line system | / | / | / | / | NT 1.10 | NT 1.10 | NT 1.10 | / | NT 1.10 | - | NT 1.10 | NT 1.10 |
| Exp. of internal timer Tn1 | / | / | NT 1.4 | / | / | / | / | / | / | / | / | / |
| SIG 2-L2 | / | - | - | NT 2.1 | NT 2.1
or - | NT 2.1
or - | / | / | / | / | - | / |
| SIG 4H-L2 | / | / | / | / | / | NT 2.2 | - | / | / | / | NT 2.2 | - |
| SIG 4-L2 | / | / | / | / | / | / | NT 2.2 | / | NT 2.2 | NT 2.2 | / | - |

- No state change.
/ Impossible by the definition of peer-to-peer physical layer procedures or system internal reasons.
ST.Tnx; NTy: Start timer x; enter state NT y.

NOTE 1: Timer T2 as defined in ETS 300 012.
NOTE 2: INFO X: signal with no framing information i.e. binary ZERO's.
NOTE 3: Any other signal which produces an error indication on the LT side is allowed, especially loss of framing or excessive error rate.
NOTE 4: The D-Echo bit is set to binary ZERO.
NOTE 5: The B- and D-channels are looped back to the network side.

The following states are used.

- NT 1.1 Deactivated state (low power consumption mode). No signal is transmitted.
- NT 1.2 The NT1 sends the awake signal SIG 1W to the LT, on the receipt of INFO 1 from the user side, and waits for the receipt of the awake acknowledge signal SIG 2W from the LT.
- NT 1.3 On receipt of the awake signal SIG 2W, the NT1 responds with SIG 1W and starts transmission of SIG 1A on expiry of timer Tn1, unless a new awake signal SIG 2W from the LT is received.
- NT 1.4 After completion of the awake procedure, the NT1 waits for SIG 2 to synchronise its receiver.
- NT 1.5 The receiver on the network side is synchronised. The NT1 sends SIG 1 to the LT and INFO 2 to the user side to initiate the activation of the interface at reference point T. It waits for the receipt of INFO 3.
- NT 1.6 The interface at T reference point is synchronised in both directions of transmission. The NT1 sends SIG 3 to the LT and waits for the receipt of SIG 4H.

- NT 1.7 The NT1 is fully active and sends INFO 4 to the user side and SIG 5 to the LT. The B-channels and D-channels are operational.
- NT 1.8 Pending deactivation state. The NT1 sends INFO 0 to the user side to deactivate the interface at reference point T and SIG 0 to the LT. It waits for the receipt of INFO 0 or expiry of timer T2 to enter state NT1.1.
- NT 1.9 This state is entered on loss of signal or loss of framing at the interface at T reference point. No indication is sent to the LT.
- NT 1.10 This state is entered on loss of framing at the line side. An indication is forwarded to the user side (INFO X) and to the network side (SIG 0).

The following states support activation when loopback 2 is requested.

- NT 2.1 The receiver on the network side is synchronised. The NT1 sends SIG 3 to the LT and INFO 2 to the user side (transparent loopback). It waits for the receipt of SIG 4H-L2 from the LT.
- NT 2.2 The NT1 is fully active and sends INFO 4 to the user side (transparent loopback) and SIG 5 to the LT. Loopback 2 is operated and receive data 2B+D are sent to the LT.

B.10.5 LT state transition table

The LT state transition table is described in table B.2. SIGs on the line system are related to FEs on the V1 reference point.

Table B.2: LT state transition table

| State | LT 1.1 | LT 1.2 | LT 1.3 | LT 1.4 | LT 1.5 | LT 1.6 | LT 1.7 | LT 1.8 | LT 2.1 | LT 2.2 | LT 2.3 | LT 2.4 |
|------------------------------------|--|--------|----------------|-------------------|-------------------|-----------------|------------|-----------------|--------|-------------------|-----------------|--------|
| transmit signal | SIG 0 | SIG 2W | SIG 2W | SIG 2 | SIG 2 | SIG 4H | SIG 4 | SIG 0 | SIG 2W | SIG 2 | SIG 4H | SIG 4 |
| receive signal | | | | | | | | | | | | |
| FE 1 | LT 1.3 | - | - | - | - | - | - | - | - | - | - | - |
| FE 5 | : | LT 1.8 | LT 1.8 | LT 1.8 | LT 1.8 | LT 1.8 | LT 1.8 | - | LT 1.8 | LT 1.8 | LT 1.8 | LT 1.8 |
| SIG 0 | - | - | - | - | FE 7;
- | FE 7;
- | FE 7;
- | FE 6;
LT 1.1 | - | - | - | - |
| SIG 1W | ST.T11;
FE 2;
LT 1.2 | : | LT 1.4 | / | / | / | / | - | - | / | / | / |
| SIG 1 | / | / | / | FE 3;
LT 1.5 | - | / | / | - | / | - | - | - |
| SIG 3 | / | / | / | ST.T12;
LT 1.6 | ST.T12;
LT 1.6 | - | - | - | / | - | - | - |
| Exp. of internal timer T11 | - | LT 1.4 | - | - | - | - | - | - | - | - | - | - |
| Exp. of internal timer T12 | - | - | - | - | - | FE 7;
LT 1.4 | - | - | - | - | FE 4;
LT 2.4 | - |
| Lost framing line system | / | / | / | / | FE 7;
- | FE 7;
- | FE 7;
- | - | / | / | / | / |
| FE 4 | ST.T14;
LT 2.1 | - | LT 2.2
or - | LT 2.2
or - | LT 2.2
or - | - | - | LT 2.1 | : | : | : | : |
| Exp. of internal timer T14 | - | - | - | - | - | - | - | - | LT 2.2 | - | - | - |
| Rec. synchron. on looped back sig. | / | / | / | - | - | - | - | - | / | ST.T12;
LT 2.3 | - | - |
| - | No state change. | | | | | | | | | | | |
| / | Impossible by the definition of peer-to-peer physical layer procedures or system internal reasons. | | | | | | | | | | | |
| : | Impossible by the definition of the physical layer. | | | | | | | | | | | |
| a, b; | LTx Perform action/issue message a and b; enter state LTx. | | | | | | | | | | | |
| ST.Tix | Start timer Tix. | | | | | | | | | | | |

The following states are used.

- LT 1.1 Deactivated state. No signal is transmitted.
- LT 1.2 On receipt of the awake signal SIG 1W, the LT responds with SIG 2W and starts transmission of SIG 2 on expiry of timer TI1, unless a new awake signal SIG 1W from the NT1 is received.
- LT 1.3 The LT sends the awake signal SIG 2W to the NT1, on the receipt of FE 1, and waits for the awake acknowledge signal SIG 1W from the NT1.
- LT 1.4 The LT sends SIG 2 to the NT1 and waits for SIG 1 or SIG 3 to synchronise its receiver. When the LT is synchronised and has detected SIG 1, it issues FE 3.
- LT 1.5 The line transmission system is synchronised in both directions of transmission. The LT waits for the receipt of SIG 3.
- LT 1.6 The line transmission system and the interface at T reference point are synchronised in both directions of transmission. The LT sends SIG 4H until the expiry of timer TI2.
- LT 1.7 Fully active state. The LT sends SIG 4 to the NT1 and issues FE 4. The B-channels and D-channel are fully operational.
- LT 1.8 Pending deactivation state. The LT sends SIG 0 to the NT1 to deactivate the line system and the interface at T reference point. It waits for the receipt of SIG 0 to enter state LT 1.1 and to issue FE 6.

The following states support activation when loopback 1 is requested.

- LT 2.1 The LT sends the awake signal SIG 2W to the NT1 (transparent loopback), on the receipt of FE 9, and starts transmission of SIG 2 on expiry of timer TI4.
- LT 2.2 The LT has operated loopback 1 and is synchronizing its receiver on the looped back signal.
- LT 2.3 The LT sends SIG 4H until the expiry of timer TI2.
- LT 2.4 The LT is fully active and sends SIG 4 to the NT1 (transparent loopback). Loopback 1 is operated.

The LT state transition table is not affected by loopback 2 and 1A requests. The corresponding control signals are transferred across channels C_{V1} and C_L .

B.10.6 Activation times

For definition of activation times see ETS 300 297 [8], subclause 8.5:

- a) maximum activation time for activation occurring immediately after a deactivation:
 - without regenerator: 210 ms;
 - with regenerator: 420 ms;
- b) maximum time for activation occurring after the first powering of a line:
 - without regenerator: 1,5 s;
 - with regenerator: 3 s.

B.11 Jitter

Jitter tolerances shall assure that the maximum network limit of jitter (see CCITT Recommendation G.823 [20]) is not exceeded. Furthermore, the limits of ETS 300 012 [9] must be supported by the jitter limits of the transmission system on local lines.

The jitter limits given below must be satisfied regardless of the length of the local line and the inclusion of repeaters, provided that they are covered by the transmission media characteristic (see Clause 3). The limits must be met regardless of the transmitted signal. A suitable test sequence is for further study (see CCITT Recommendation G.823 [20], § 4).

B.11.1 Limits of maximum tolerable input jitter

The amplitude of the jitter at the NT1 input shall be limited by the template given in figure B.3.

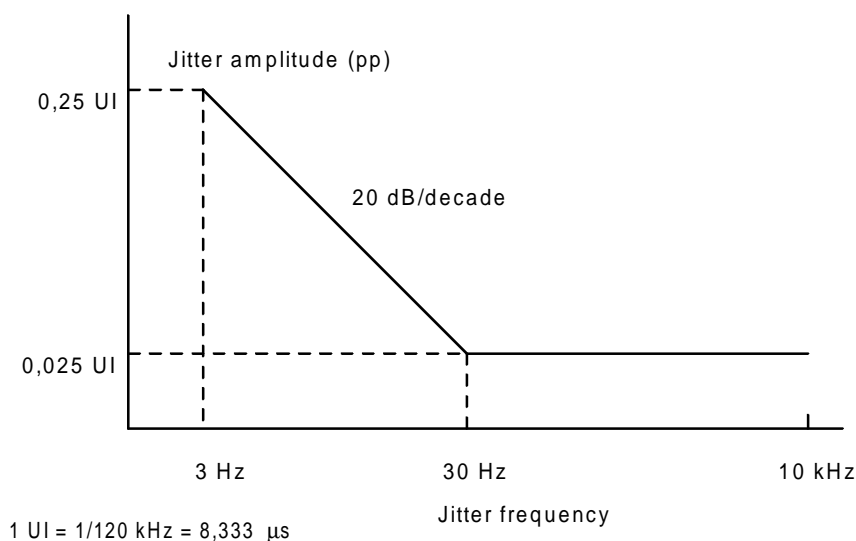

Figure B.3: Maximum tolerable sinusoidal input jitter

B.11.2 Output jitter of NT1 in absence of input jitter

When measured with a highpass filter with a 30 Hz cut-off frequency, the jitter at the output of the NT1 shall not exceed 0,02 UIpp. Without a filter, the jitter shall not exceed 0,1 UIpp.

B.11.3 Timing extraction jitter

The jitter at the output of the NT1 shall closely follow the input jitter. Therefore, the jitter transfer function of the NT1 shall be less than ± 1 dB in the frequency range 3 Hz to 30 Hz.

B.11.4 Test conditions for jitter measurements

For further study.

B.12 Transmitter output characteristics

B.12.1 Pulse amplitude

The amplitude of a transmitted single pulse shall be $2\text{ V} \pm 0,2\text{ V}$ with a load impedance of $150\ \Omega$.

B.12.2 Pulse shape

The shape of a transmitted single pulse shall fit the mask given in figure B.4.

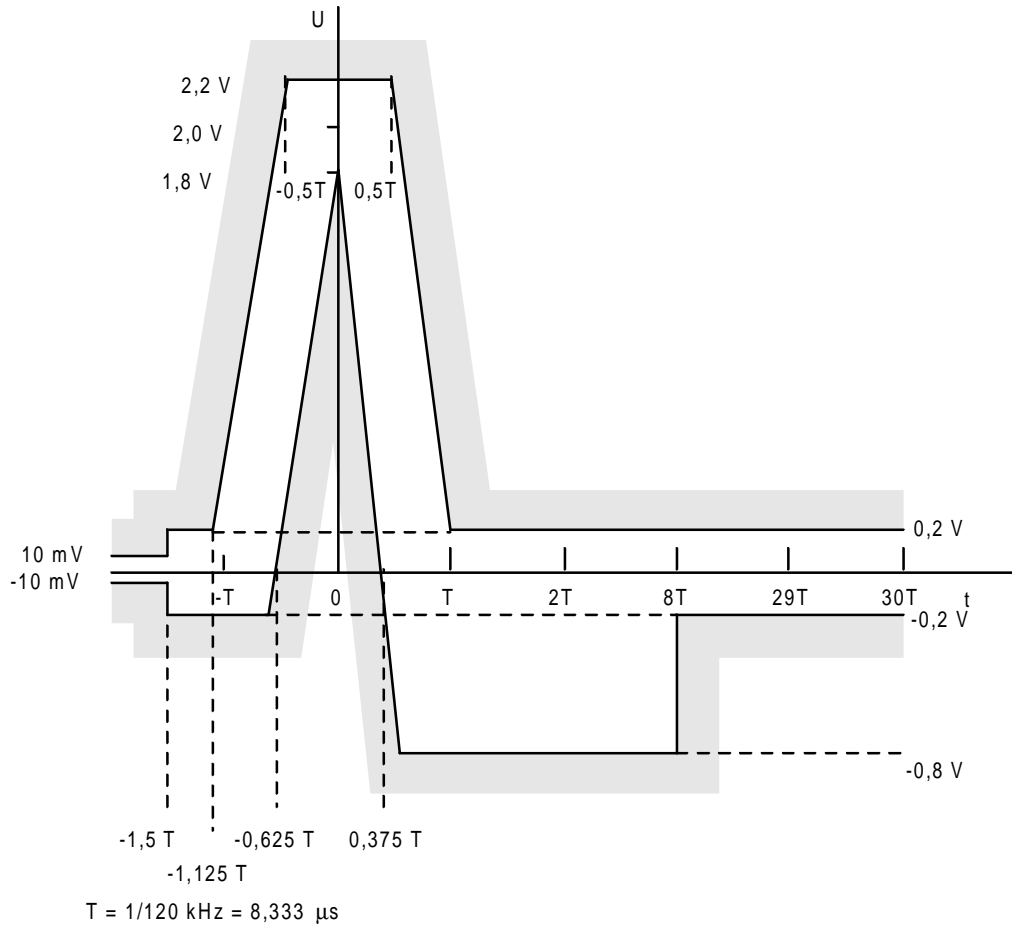

Figure B.4: Pulse mask for transmitted single pulse

B.12.3 Signal power

Not specified.

B.12.4 Power spectrum

The upper bound of the power spectral density shall be limited according to figure B.5.

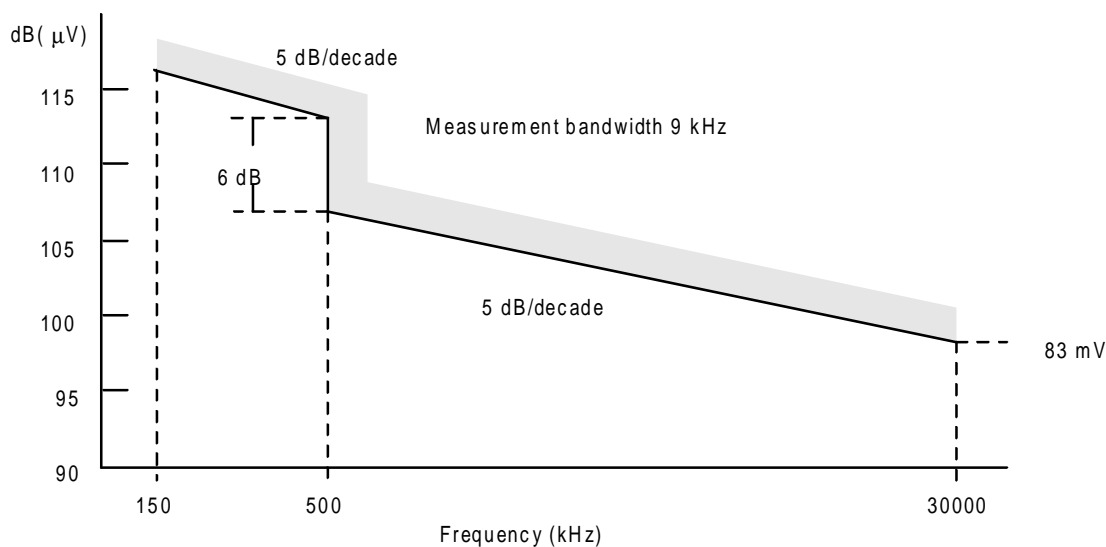

Figure B.5: Limits of transmit power spectrum

B.12.5 Transmitter signal nonlinearity

Not specified.

B.13 Transmitter/receiver termination

B.13.1 Impedance

The nominal output/input impedance of the NT1 and LT shall be 150 Ω.

B.13.2 Return loss

The return loss against 150 Ω ± 1% measured for NT1 or LT shall exceed the limits given in figure B.6.

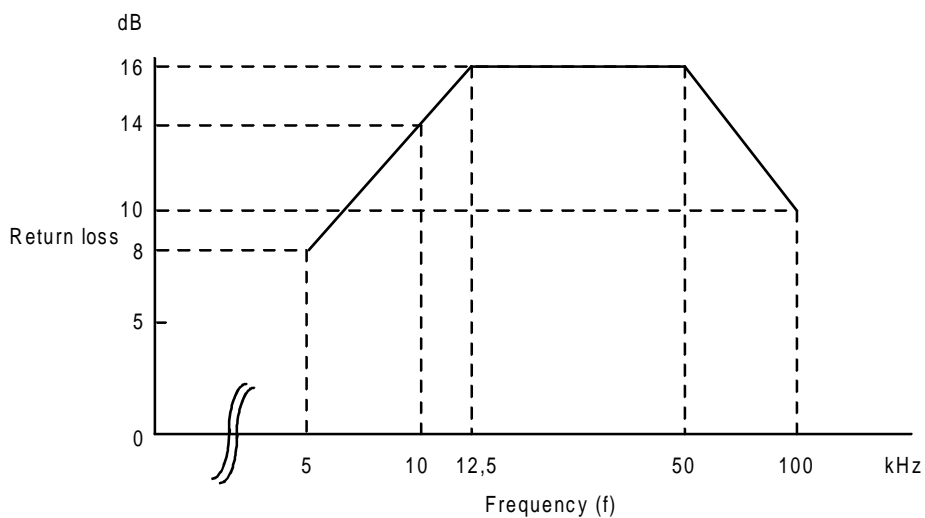

Figure B.6: Minimum NT1 and LT return loss

B.13.3 Longitudinal conversion loss

The longitudinal conversion loss at the line interface for LT and NT1 shall exceed the limits given in figure B.7.

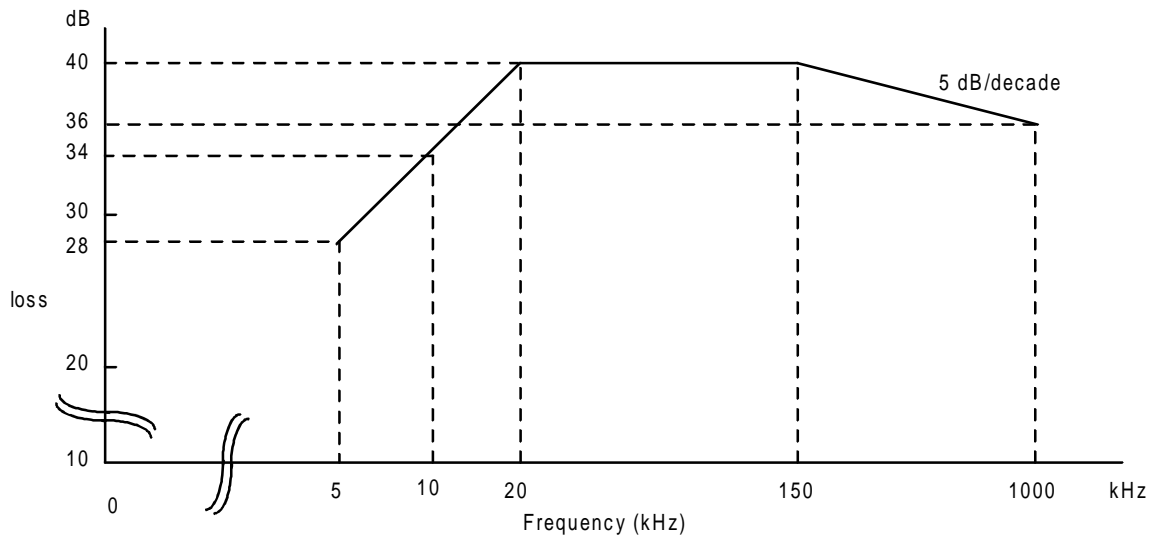

Figure B.7: Minimum longitudinal conversion loss

Appendix III: Extension functions and requirements for a line system with MMS43 line code

No extension functions and requirements have been defined yet.

Annex C: Detailed test cable characteristics

C.1 Parameters for test cables

C.1.1 Parameters of 0,4 mm PE cable

| Frequency (kHz) | 10 | 20 | 40 | 100 | 200 | 400 |
|--------------------|------|------|------|------|------|------|
| R' (Ω /km) | 268 | 269 | 271 | 282 | 312 | 390 |
| L' (μ H/km) | 678 | 675 | 669 | 650 | 635 | 619 |
| C' (nF/km) | 45,5 | 45,5 | 45,5 | 45,5 | 45,5 | 45,5 |

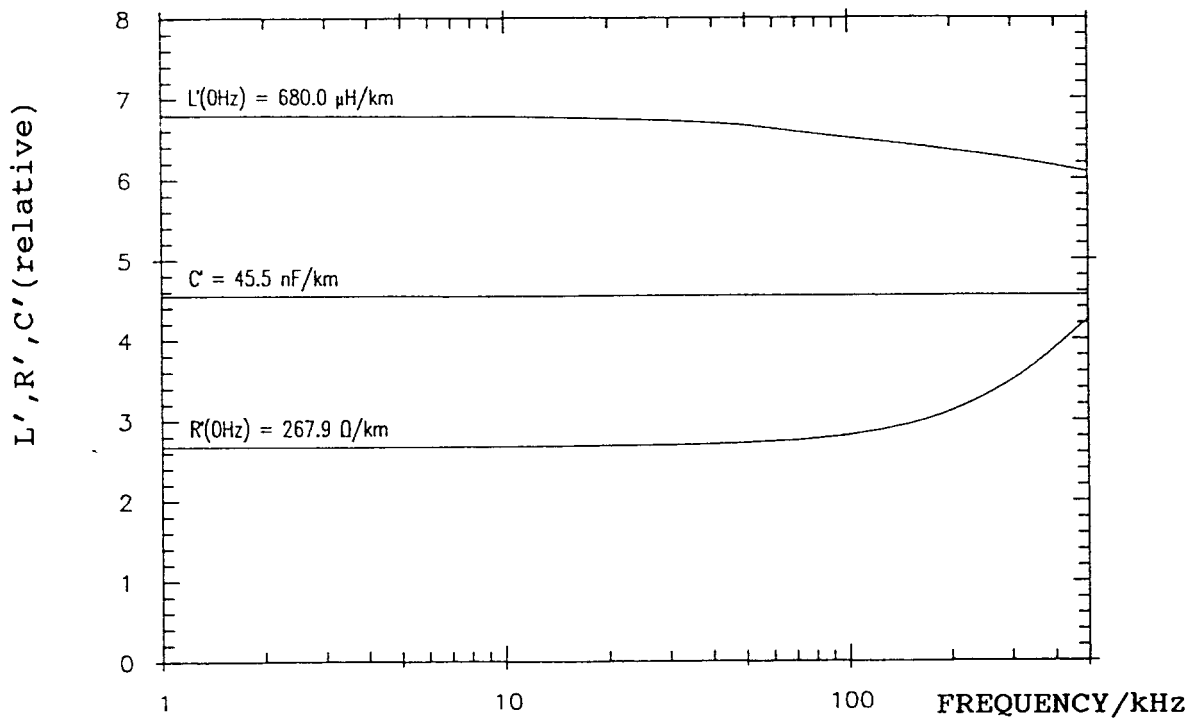

Figure C.1: Parameters of 0,4 mm PE cable

C.1.2 Parameters of 0,5 mm PE cable

| Frequency (kHz) | 10 | 20 | 40 | 100 | 200 | 400 |
|--------------------|-----|-----|-----|-----|-----|-----|
| R' (Ω /km) | 172 | 173 | 175 | 190 | 227 | 302 |
| L' (μ H/km) | 678 | 675 | 667 | 646 | 629 | 603 |
| C' (nF/km) | 25 | 25 | 25 | 25 | 25 | 25 |

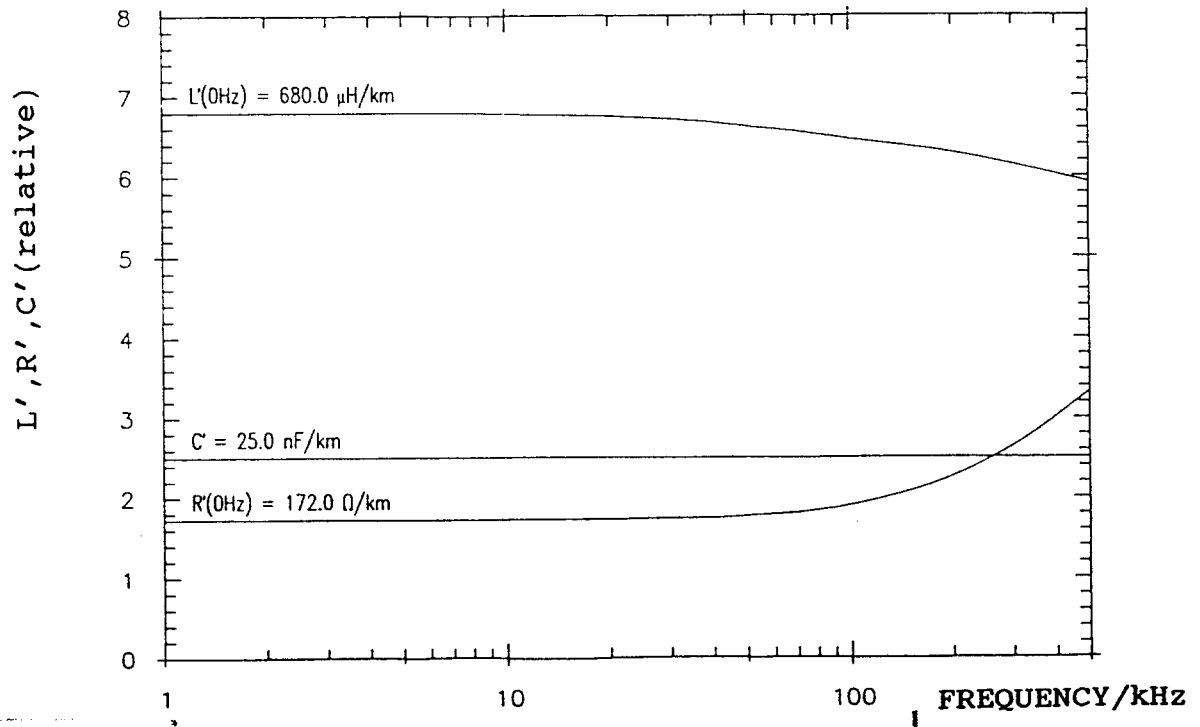

Figure C.2: Parameters of 0,5 mm PE cable

C.1.3 Parameters of 0,6 mm PE cable

| Frequency (kHz) | 10 | 20 | 40 | 100 | 200 | 400 |
|--------------------|-----|-----|-----|-----|-----|-----|
| R' (Ω /km) | 120 | 121 | 125 | 146 | 189 | 260 |
| L' (μ H/km) | 695 | 693 | 680 | 655 | 633 | 601 |
| C' (nF/km) | 56 | 56 | 56 | 56 | 56 | 56 |

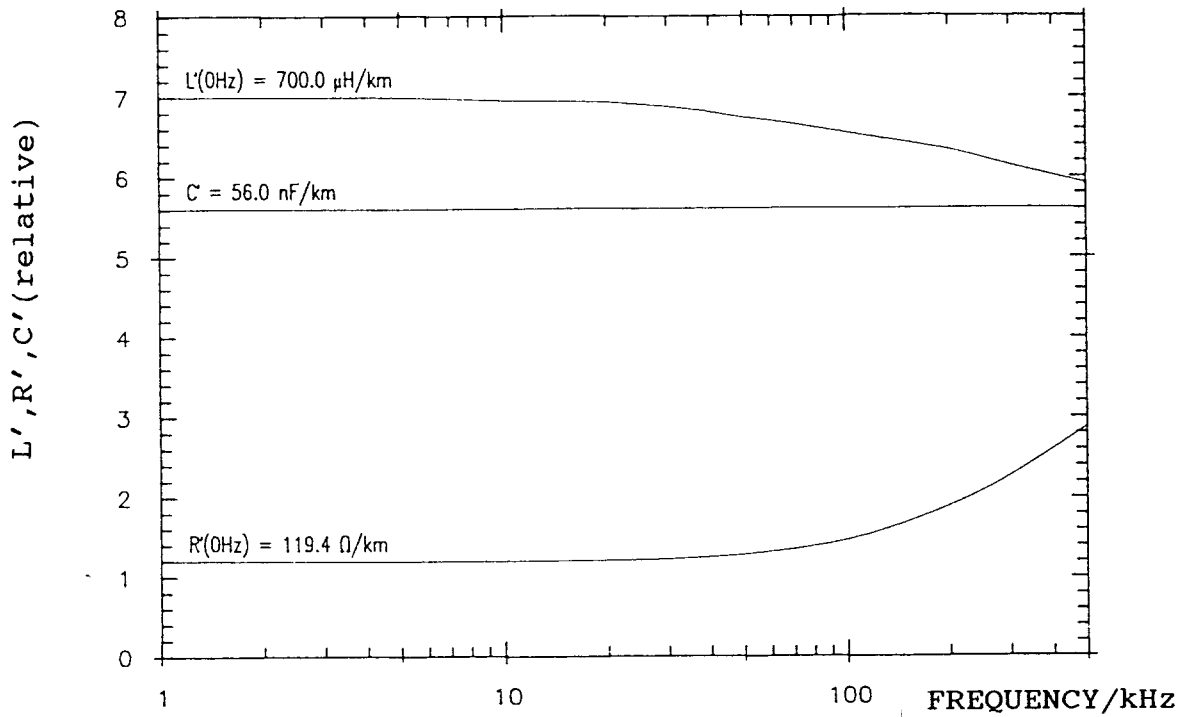

Figure C.3: Parameters of 0,6 mm PE cable

C.1.4 Parameters of 0,8 mm PE cable

| Frequency (kHz) | 10 | 20 | 40 | 100 | 200 | 400 |
|--------------------|------|------|------|------|------|------|
| R' (Ω /km) | 80,0 | 72,5 | 75,0 | 91,7 | 117 | 159 |
| L' (μ H/km) | 700 | 687 | 665 | 628 | 595 | 558 |
| C' (nF/km) | 37,8 | 37,8 | 37,8 | 37,8 | 37,8 | 37,8 |

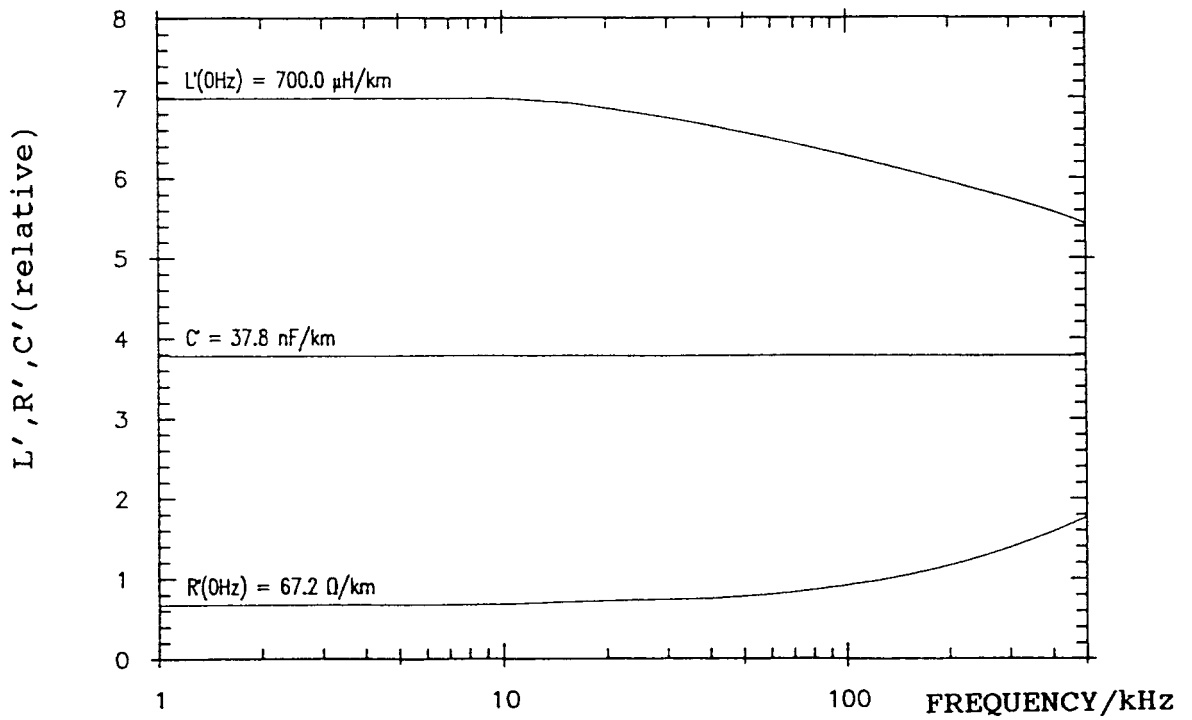

Figure C.4: Parameters of 0,8 mm PE cable

C.1.5 Parameters of 0,32 mm PVC cable

| Frequency (kHz) | 10 | 20 | 40 | 100 | 200 | 400 |
|--------------------|-----|-----|-----|-----|-----|-----|
| R' (Ω /km) | 419 | 419 | 419 | 427 | 493 | 679 |
| L' (μ H/km) | 650 | 650 | 650 | 647 | 621 | 577 |
| C' (nF/km) | 120 | 120 | 120 | 120 | 120 | 120 |

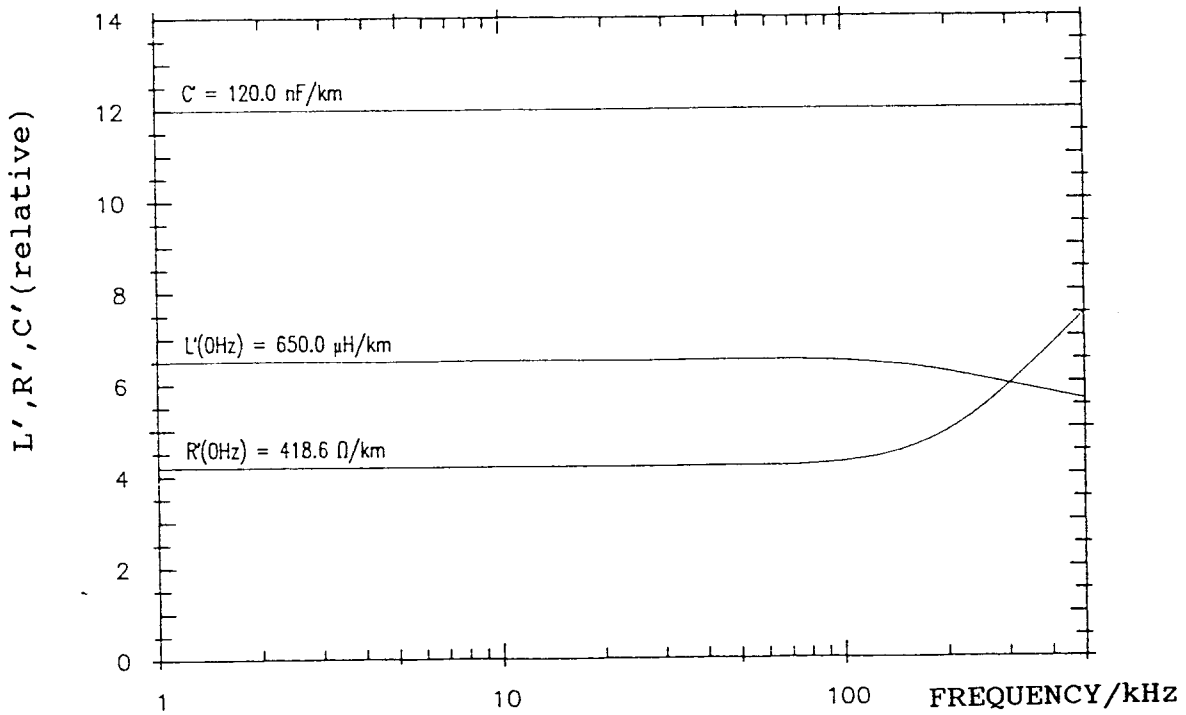

Figure C.5: Parameters of 0,32 mm PVC cable

C.1.6 Parameters of 0,4 mm PVC cable

| Frequency (kHz) | 10 | 20 | 40 | 100 | 200 | 400 |
|--------------------|-----|-----|-----|-----|-----|-----|
| R' (Ω /km) | 268 | 268 | 268 | 281 | 311 | 391 |
| L' (μ H/km) | 650 | 650 | 650 | 635 | 619 | 592 |
| C' (nF/km) | 120 | 120 | 120 | 120 | 120 | 120 |

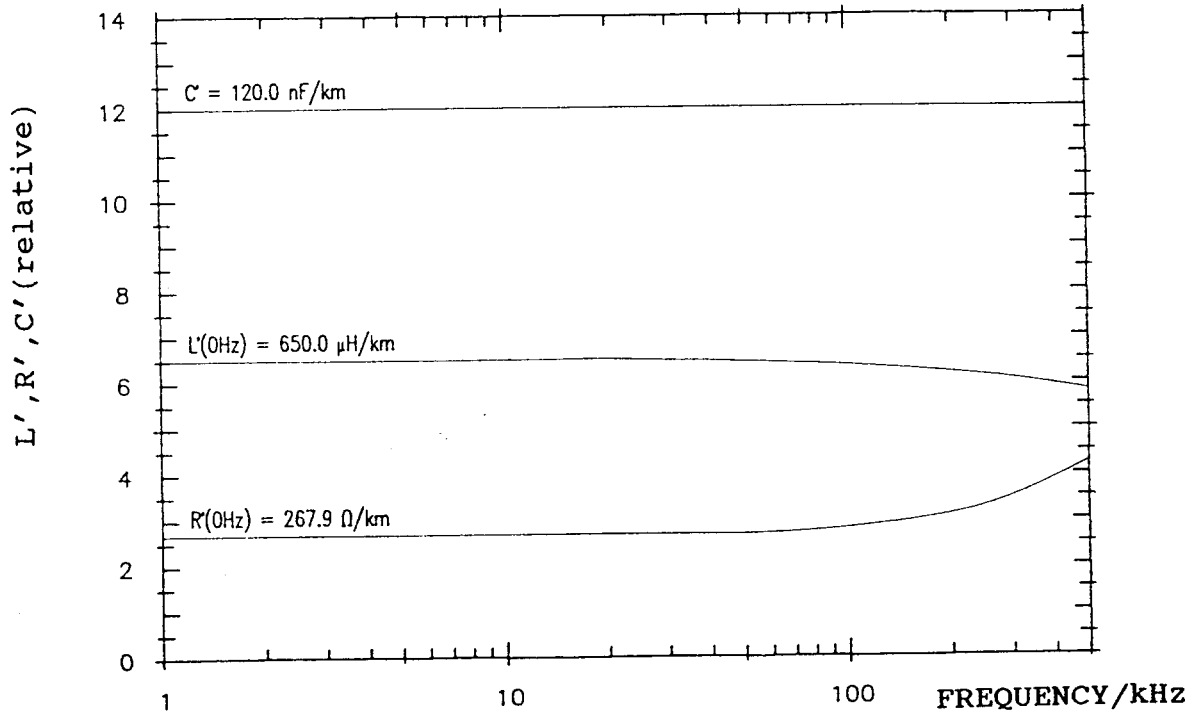

Figure C.6: Parameters of 0,4 mm PVC cable

C.1.7 Parameters of 0,63 mm PVC cable

| Frequency (kHz) | 10 | 20 | 40 | 100 | 200 | 400 |
|--------------------|-----|-----|-----|-----|-----|-----|
| R' (Ω /km) | 108 | 108 | 111 | 141 | 207 | 319 |
| L' (μ H/km) | 635 | 635 | 630 | 604 | 560 | 492 |
| C' (nF/km) | 120 | 120 | 120 | 120 | 120 | 120 |

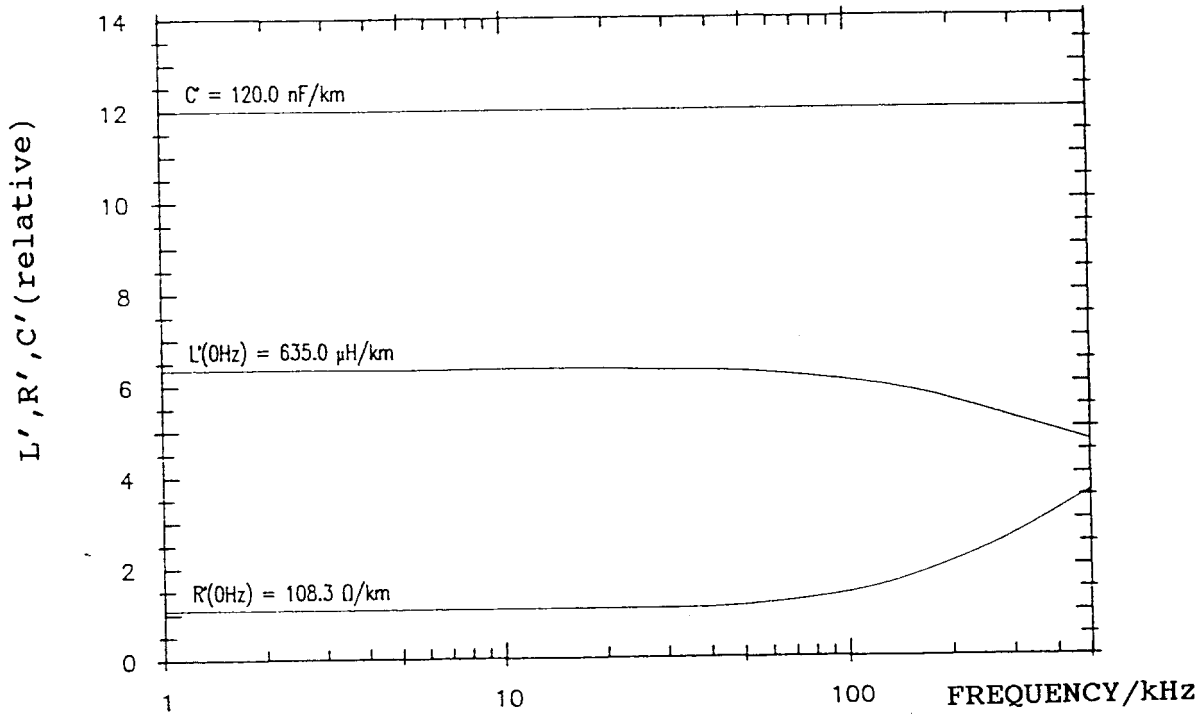

Figure C.7: Parameters of 0,63 mm PVC cable

C.2 Impedance plot of test loops

C.2.1 Impedance plot at 10 kHz

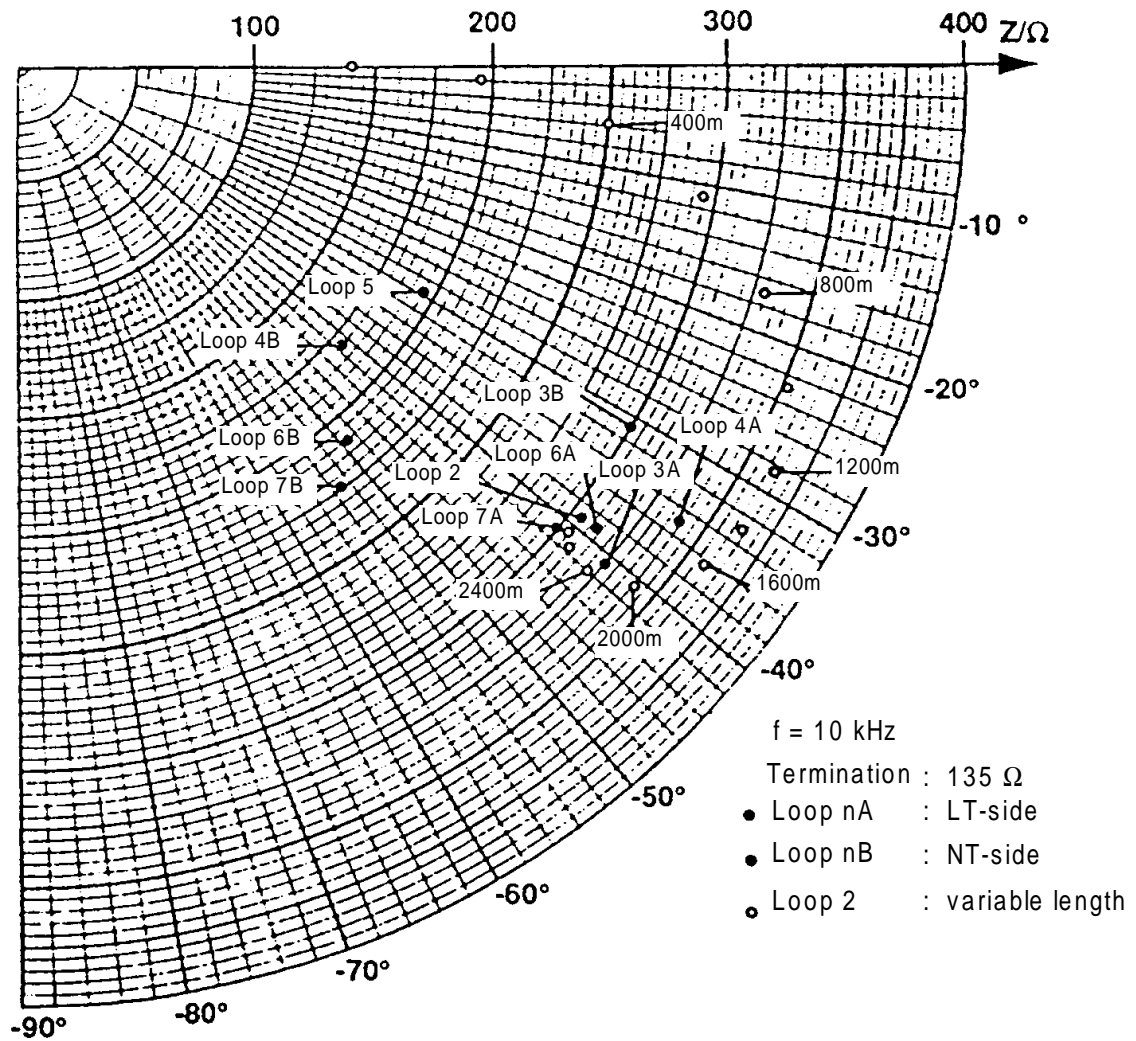

Figure C.8: Impedance plot at 10 kHz

C.2.2 Impedance plot at 20 kHz

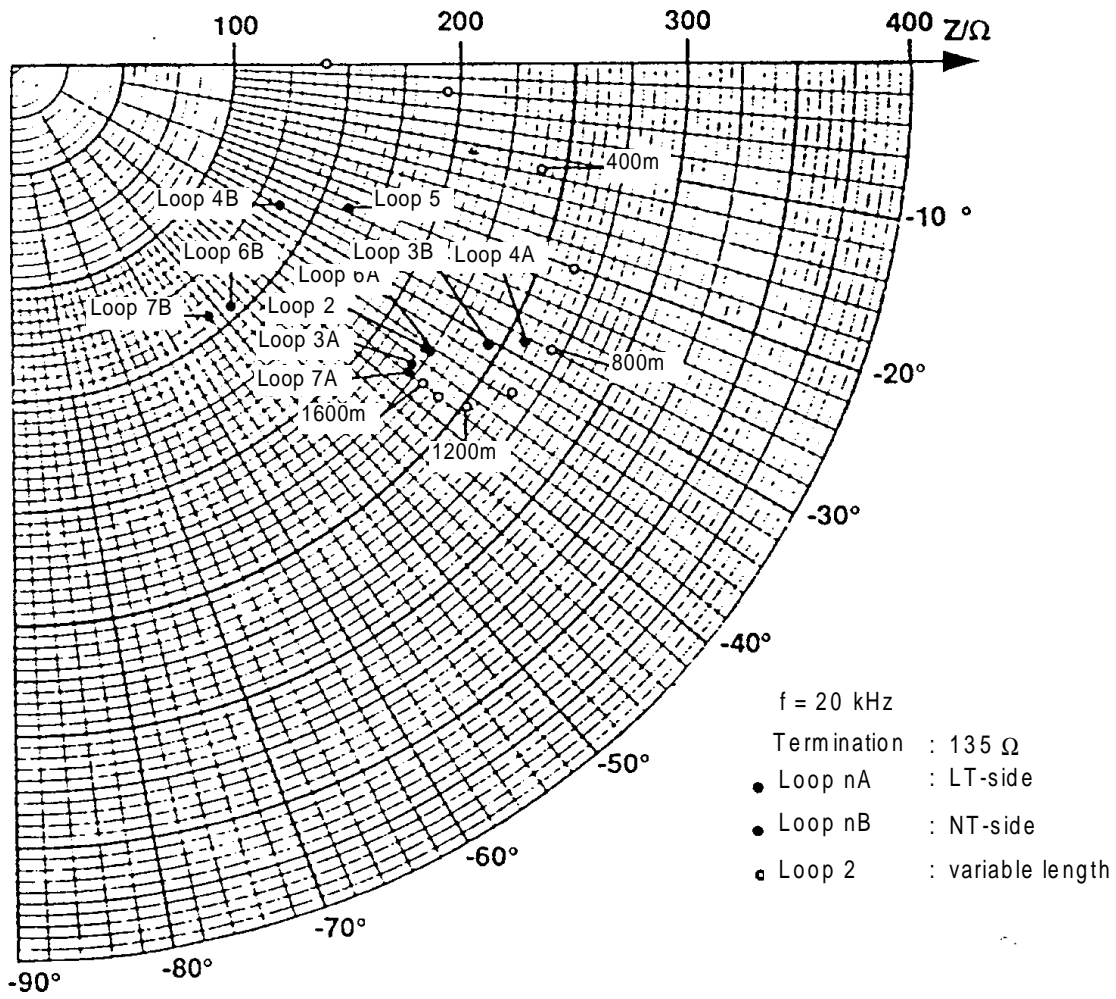

Figure C.9: Impedance plot at 20 kHz

C.2.3 Impedance plot at 40 kHz

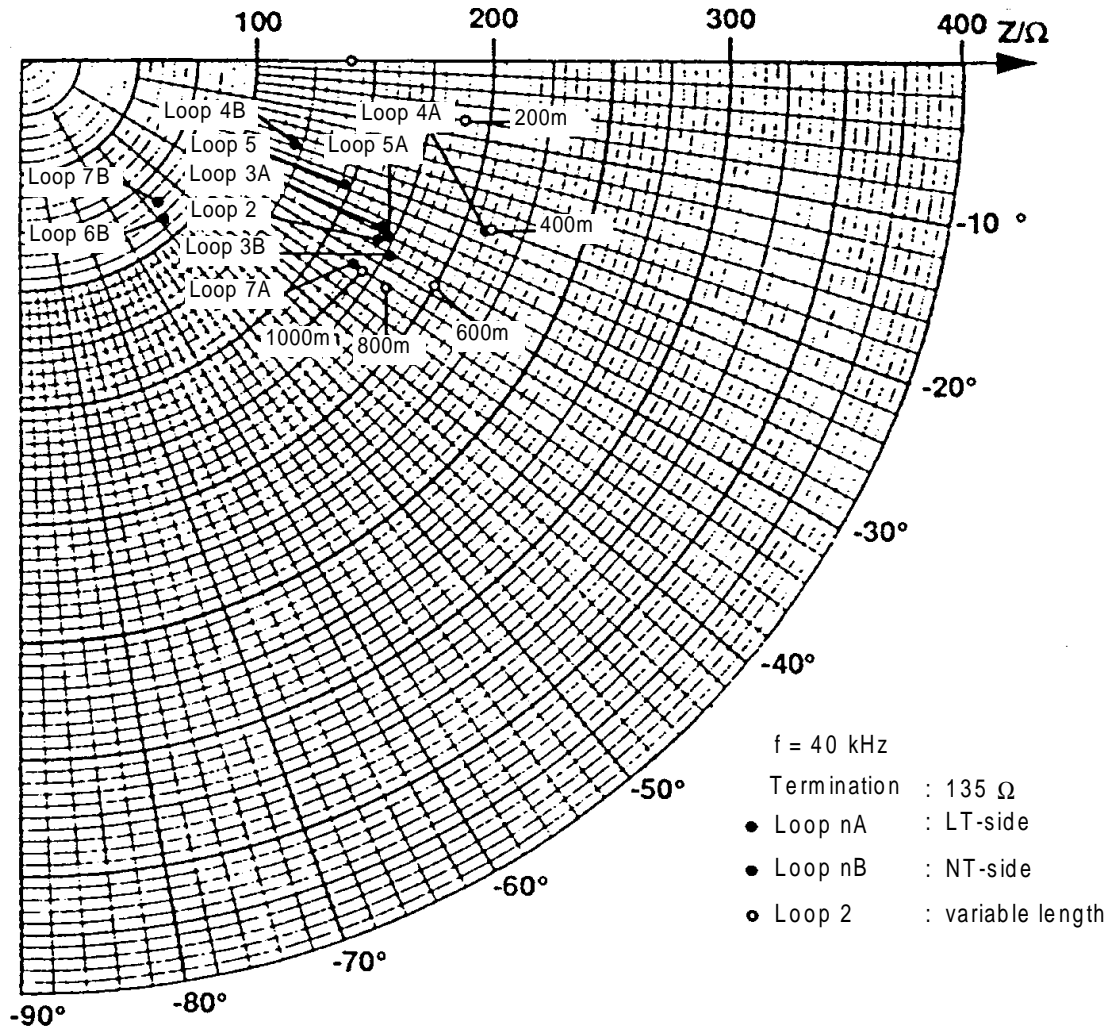

Figure C.10: Impedance plot at 40 kHz

C.3 Frequency response of test loops

C.3.1 Frequency response of loop 2

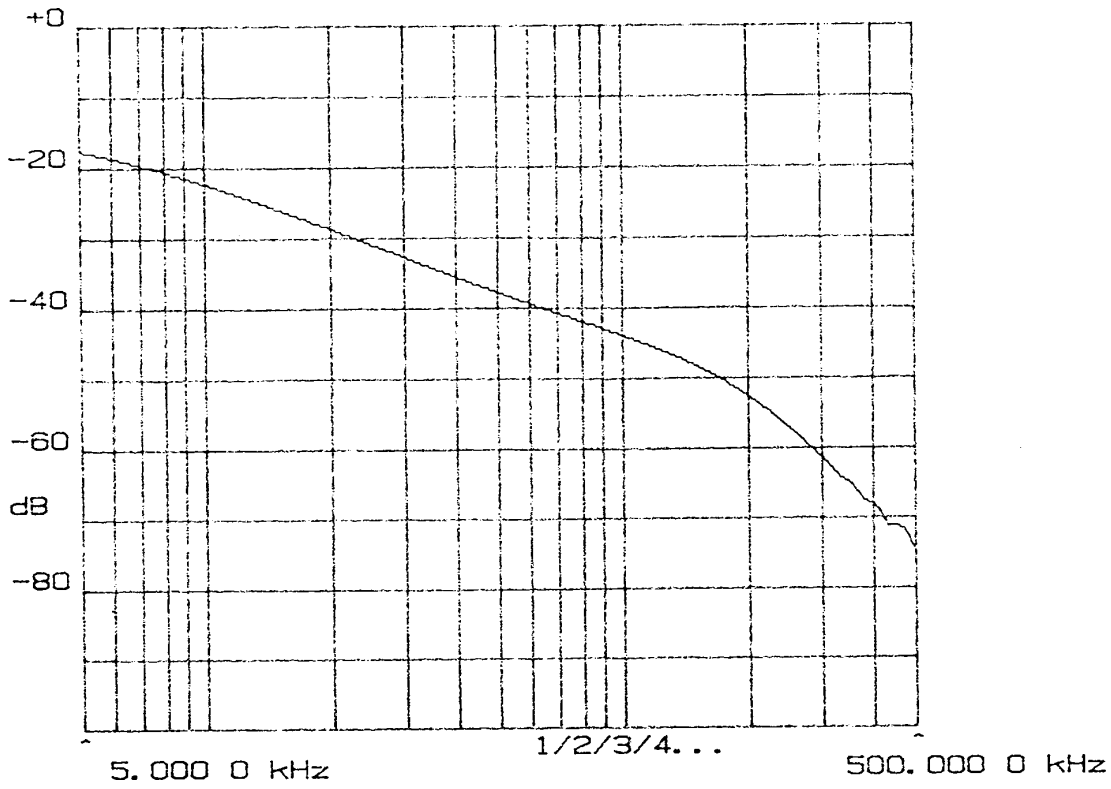

Figure C.11: Frequency response of loop 2

C.3.2 Frequency response of loop 3

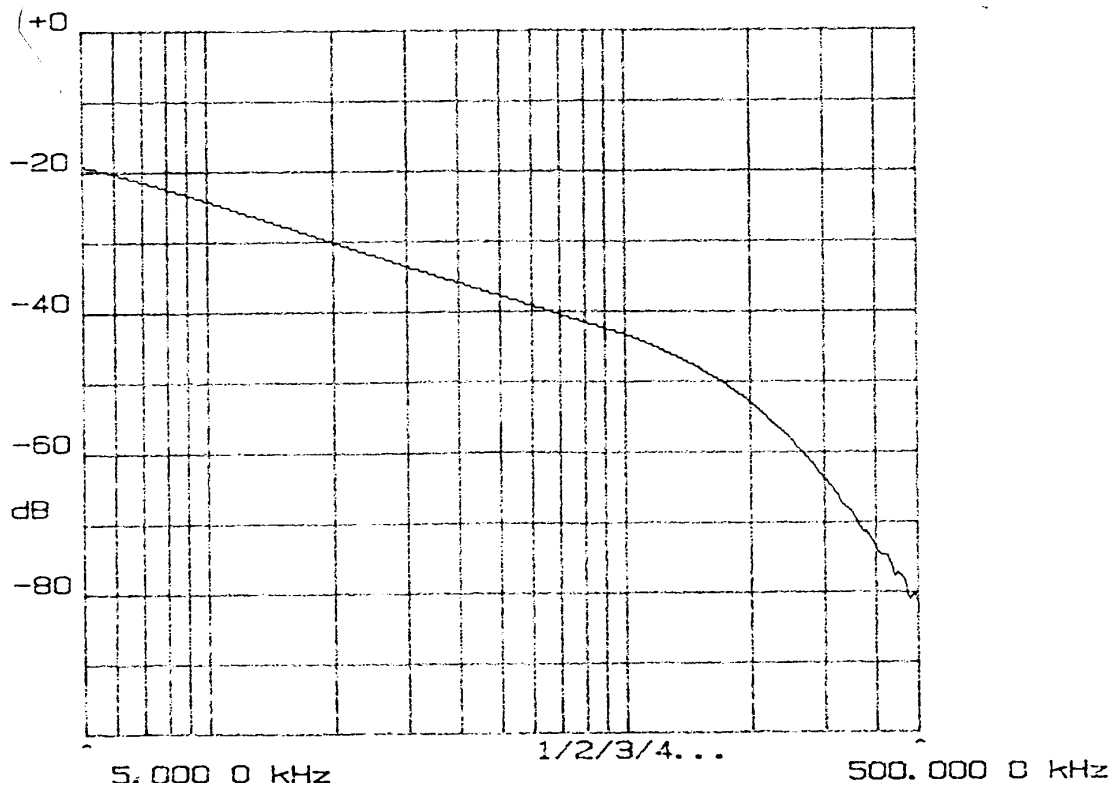

Figure C.12: Frequency response of loop 3

C.3.3 Frequency response of loop 4

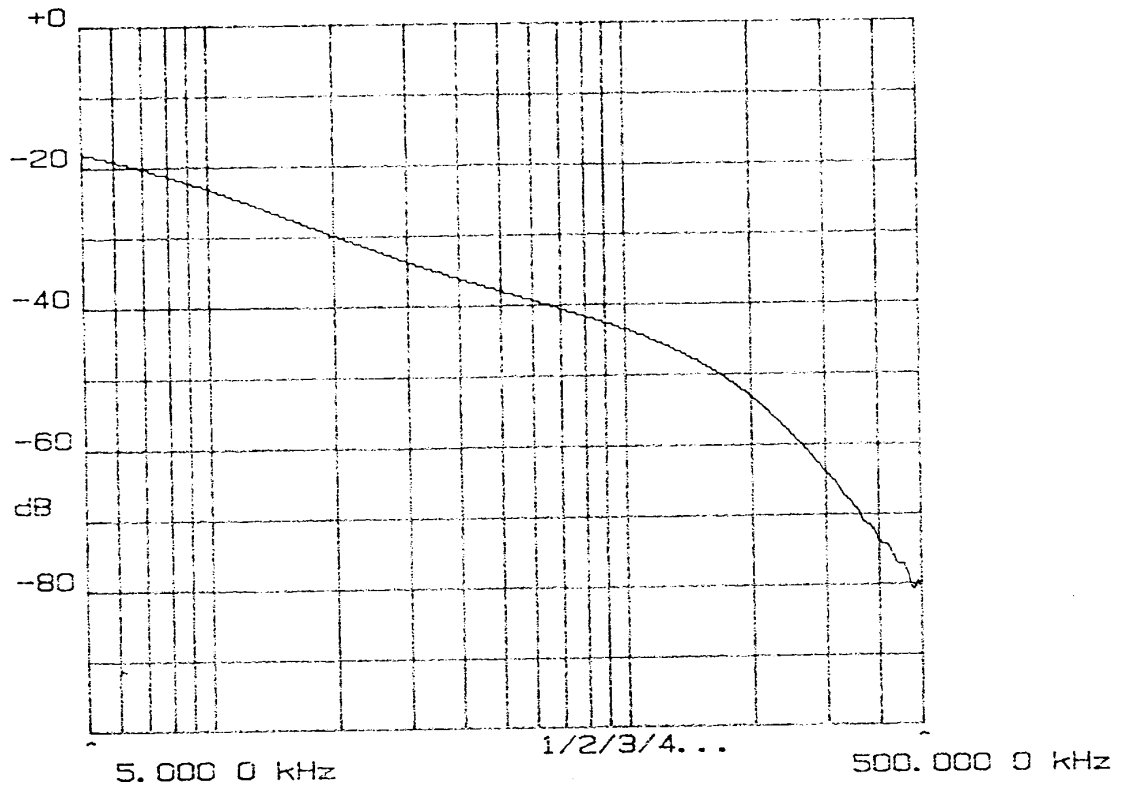

Figure C.13: Frequency response of loop 4

C.3.4 Frequency response of loop 5

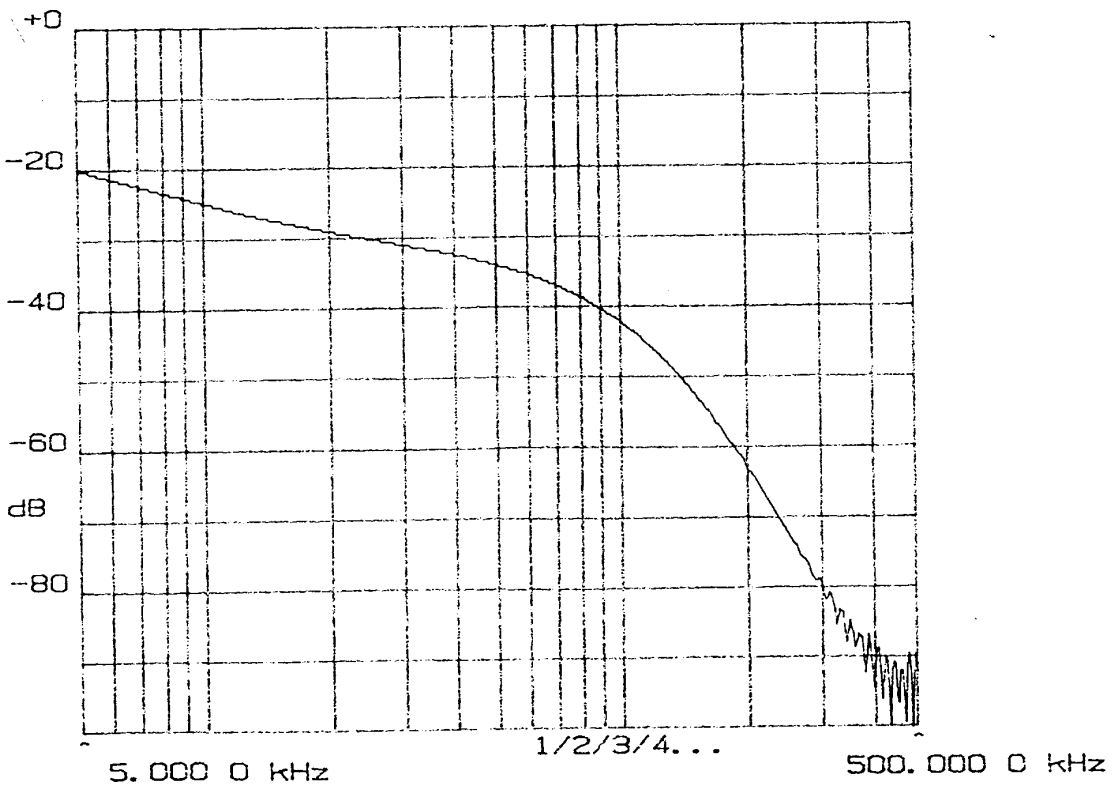

Figure C.14: Frequency response of loop 5

C.3.5 Frequency response of loop 6

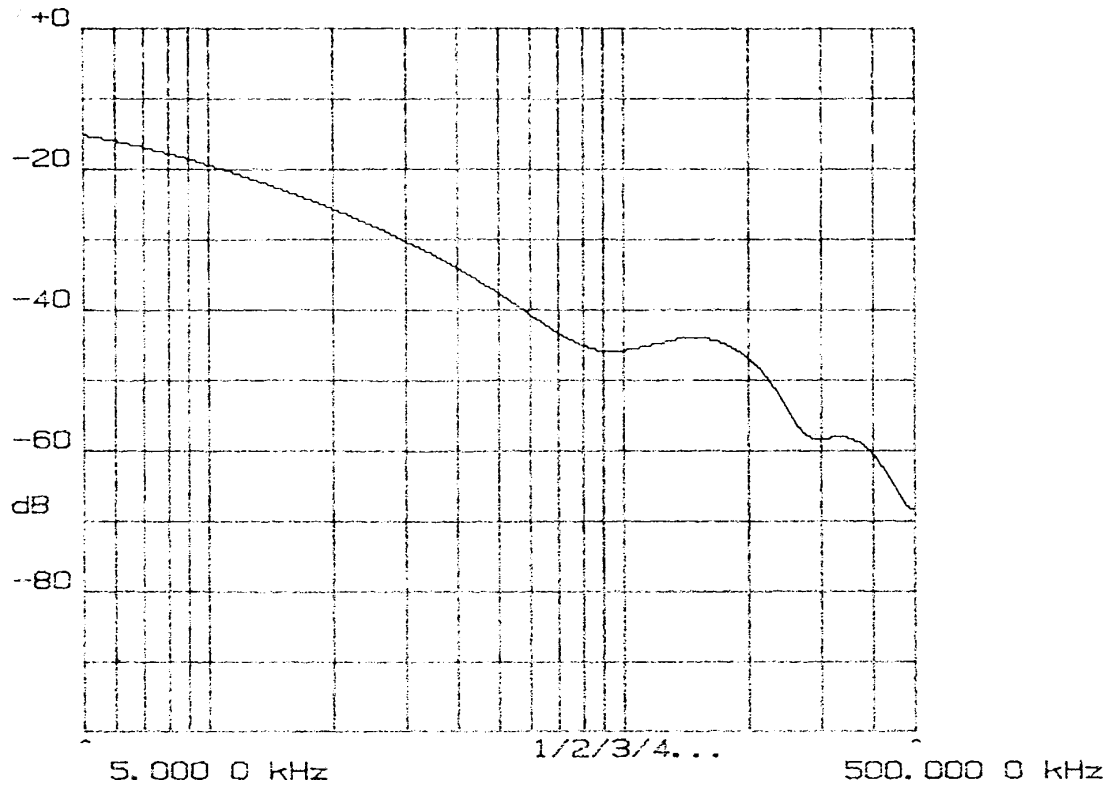

Figure C.15: Frequency response of loop 6

C.3.6 Frequency response of loop 7

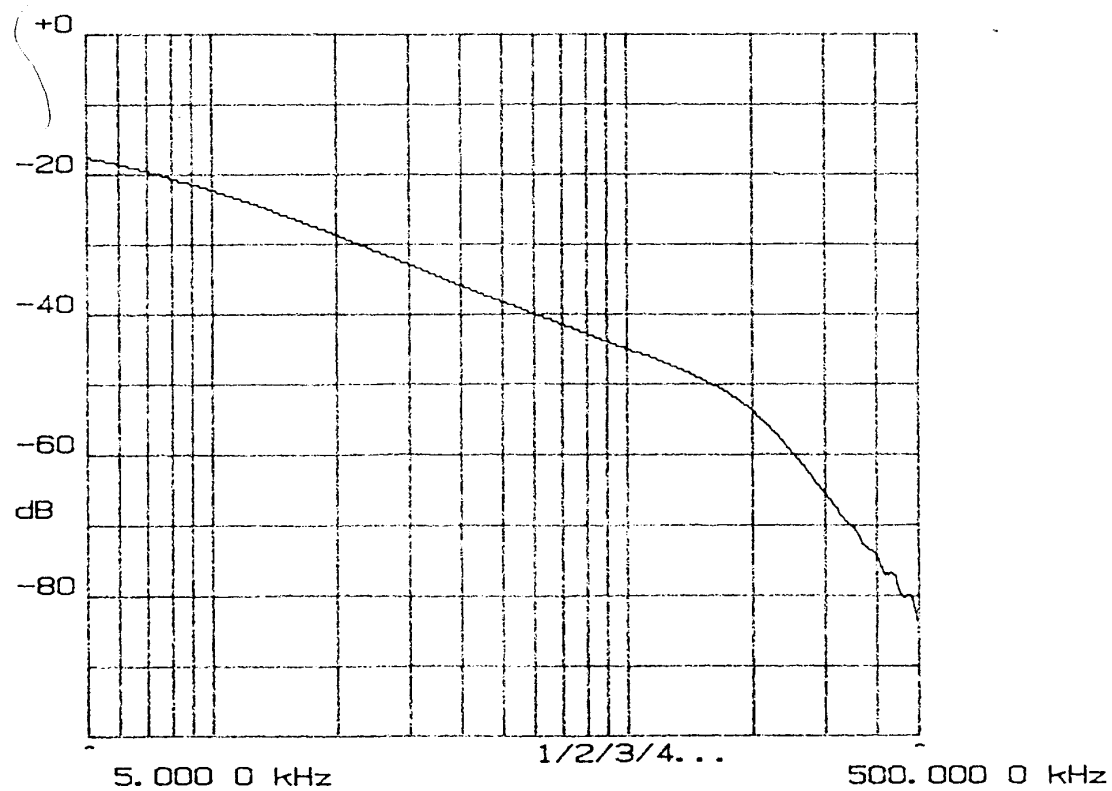

Figure C.16: Frequency response of loop 7

C.3.7 Frequency response of loop 8

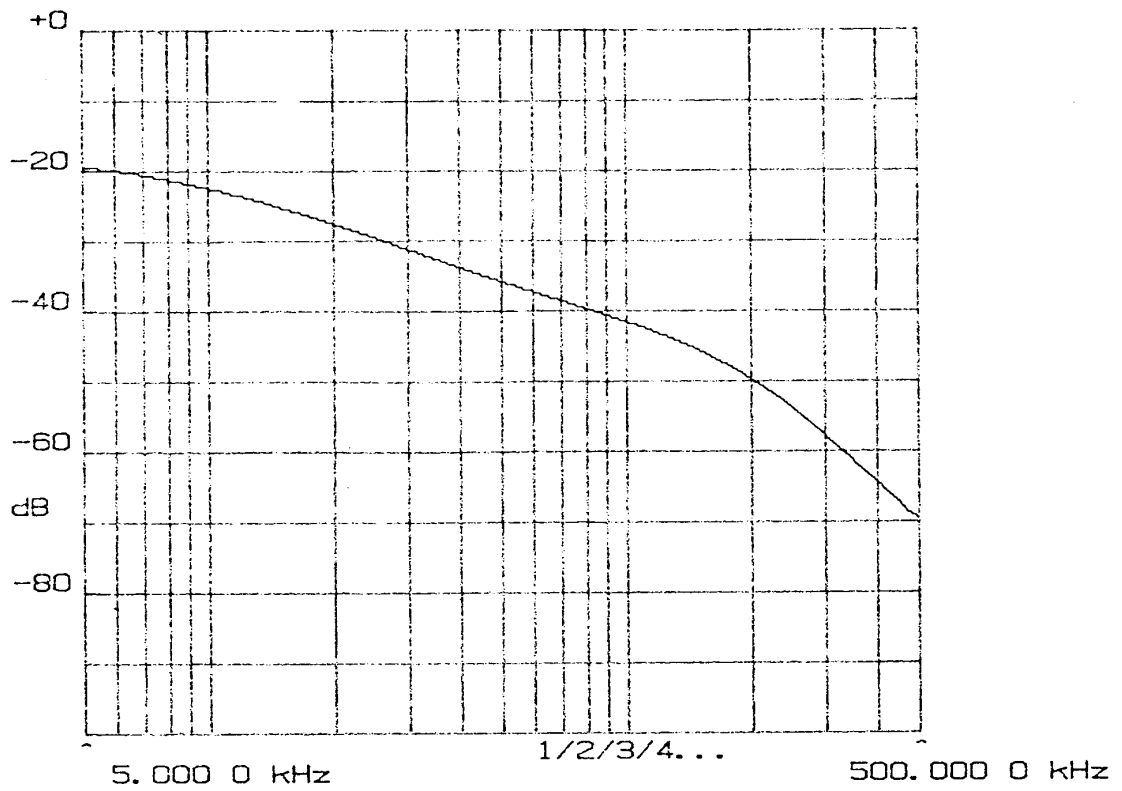

Figure C.17: Frequency response of loop 8

History

| Document history | |
|------------------|---|
| July 1993 | First Edition |
| March 1996 | Converted into Adobe Acrobat Portable Document Format (PDF) |
| | |
| | |
| | |