

**Telecommunications and Internet converged Services and
Protocols for Advanced Networking (TISPAN);
Resource and Admission Control;
Protocol for QoS reservation information exchange between
the Service Policy Decision Function (SPDF) and the
Access-Resource and Admission Control Function (A-RACF)
in the Resource and Protocol specification**



Reference

DES/TISPAN-03052-NGN-R1

Keywords

interface, stage 3

ETSI

650 Route des Lucioles
F-06921 Sophia Antipolis Cedex - FRANCE

Tel.: +33 4 92 94 42 00 Fax: +33 4 93 65 47 16

Siret N° 348 623 562 00017 - NAF 742 C
Association à but non lucratif enregistrée à la
Sous-Préfecture de Grasse (06) N° 7803/88

Important notice

Individual copies of the present document can be downloaded from:

<http://www.etsi.org>

The present document may be made available in more than one electronic version or in print. In any case of existing or perceived difference in contents between such versions, the reference version is the Portable Document Format (PDF). In case of dispute, the reference shall be the printing on ETSI printers of the PDF version kept on a specific network drive within ETSI Secretariat.

Users of the present document should be aware that the document may be subject to revision or change of status. Information on the current status of this and other ETSI documents is available at

<http://portal.etsi.org/tb/status/status.asp>

If you find errors in the present document, please send your comment to one of the following services:

http://portal.etsi.org/chaicor/ETSI_support.asp

Copyright Notification

No part may be reproduced except as authorized by written permission.
The copyright and the foregoing restriction extend to reproduction in all media.

© European Telecommunications Standards Institute 2006.
All rights reserved.

DECTTM, **PLUGTESTS**TM and **UMTS**TM are Trade Marks of ETSI registered for the benefit of its Members.
TIPHONTM and the **TIPHON logo** are Trade Marks currently being registered by ETSI for the benefit of its Members.
3GPPTM is a Trade Mark of ETSI registered for the benefit of its Members and of the 3GPP Organizational Partners.

Contents

Intellectual Property Rights	5
Foreword.....	5
1 Scope	6
2 References	6
3 Definitions and abbreviations.....	7
3.1 Definitions	7
3.2 Abbreviations	7
4 Rq interface	8
4.1 Overview	8
4.2 Rq reference model	8
4.3 Functional elements and capabilities	8
4.3.1 Service Policy Decision Function (SPDF).....	8
4.3.2 Access-Resource Admission Control Function (A-RACF)	8
5 Resource control procedures	9
5.1 Procedures at the SPDF	10
5.1.1 Initial Reservation for a Session	10
5.1.2 Session Modification	11
5.1.3 Session Termination	12
5.1.4 Event notification.....	12
5.2 Procedures at the A-RACF.....	13
5.2.1 Initial Reservation for a Session	13
5.2.2 Session Modification	15
5.2.3 Session Termination	15
5.2.4 Event Notification.....	15
6. Rq protocol.....	16
6.1 Protocol support	16
6.1.1 Advertising Application Support	16
6.1.2 Transport protocol	16
6.1.3 Securing Rq messages	16
6.2 Rq messages	16
6.2.1 AA-Request (AAR) Command.....	17
6.2.2 AA-Answer (AAA) Command.....	17
6.2.3 Re-Auth-Request (RAR) Command	17
6.2.4 Re-Auth-Answer (RAA) Command	18
6.2.5 Session-Termination-Request (STR) Command.....	18
6.2.6 Session-Termination-Answer (STA) Command.....	18
6.2.7 Abort-Session-Request (ASR) Command	19
6.2.8 Abort-Session-Answer (ASA) Command.....	19
6.3 Experimental-Result-Code AVP values	20
6.3.1 Experimental-Result-Code AVP values imported from TS 129 209	20
6.3.2 Experimental-Result-Code AVP values defined in the present document.....	20
6.4 AVPs	20
6.4.1 AVPs defined in the present document.....	20
6.4.2 AVPs imported from TS 129 209	21
6.4.3 AVPs imported from TS 183 017	21
6.4.4 AVPs imported from ES 283 034	22
6.4.5 Abort-Cause AVP	22
6.4.6 AF-Application-Identifier AVP	22
6.4.7 Flow-Description AVP	23
6.4.8 Flow-Grouping AVP.....	23
6.4.9 Flow-Number AVP.....	23
6.4.10 Flows AVP.....	23
6.4.11 Flow-Status AVP.....	24

6.4.12	Flow-Usage AVP	24
6.4.13	Specific-Action AVP	24
6.4.14	Max-Requested-Bandwidth-DL AVP	25
6.4.15	Max-Requested-Bandwidth-UL AVP	25
6.4.16	Media-Component-Description AVP	25
6.4.17	Media-Component-Number AVP	26
6.4.18	Media-Sub-Component AVP	26
6.4.19	Media-Type AVP	26
6.4.20	Reservation-Class AVP	26
6.4.21	Globally-Unique-Address AVP	26
6.4.22	Address-Realm AVP	27
6.4.23	Reservation-Priority AVP	27
6.4.24	Session-Bundle-Id AVP	27
6.4.25	AF-Charging-Identifier AVP	27
Annex A (informative):	Resource reservation flow states maintained by A-RACF	28
History		30

Intellectual Property Rights

IPRs essential or potentially essential to the present document may have been declared to ETSI. The information pertaining to these essential IPRs, if any, is publicly available for **ETSI members and non-members**, and can be found in ETSI SR 000 314: "*Intellectual Property Rights (IPRs); Essential, or potentially Essential, IPRs notified to ETSI in respect of ETSI standards*", which is available from the ETSI Secretariat. Latest updates are available on the ETSI Web server (<http://webapp.etsi.org/IPR/home.asp>).

Pursuant to the ETSI IPR Policy, no investigation, including IPR searches, has been carried out by ETSI. No guarantee can be given as to the existence of other IPRs not referenced in ETSI SR 000 314 (or the updates on the ETSI Web server) which are, or may be, or may become, essential to the present document.

Foreword

This ETSI Standard (ES) has been produced by ETSI Technical Committee Telecommunications and Internet converged Services and Protocols for Advanced Networking (TISPAN), and is now submitted for the ETSI standards Membership Approval Procedure.

1 Scope

The present document provides the stage 3 specification of the Rq interface. The functional requirements and the stage 2 specifications of the Rq interface are contained in ES 282 001 [1] and ES 282 003 [2]. The Rq interface is the interface between the Service Policy Decision Function (SPDF) and the Access - Resource and Admission Control Function (A-RACF) and is used for QoS resource reservation information exchange between the SPDF and the A-RACF. Via the Rq interface the SPDF issues requests for resources in the access network, indicating IP QoS characteristics. The A-RACF uses the IP QoS information to perform admission control and indicate to the SPDF via the Rq interface its admission control decisions. Due to the possible business roles in an access environment, the SPDF may be either in the same domain or in a different domain as the A-RACF.

The present document defines:

- The information to be exchanged between SPDF and A-RACF over the Rq interface.
- An Rq interface definition based on the Diameter protocol.

In situations where no generic overload control mechanism is used on the Rq interface, the interface shall only be capable of supporting a one-to-one relationship between the A-RACF and SPDF (i.e. one SPDF may only contact one A-RACF, and that A-RACF may only contact that same SPDF). Overload control need not be supported in this situation due to the fact that it should be possible to traffic engineer the capabilities of the two entities, so that the capacity of one entity matches the capacity of the other.

2 References

The following documents contain provisions which, through reference in this text, constitute provisions of the present document.

- References are either specific (identified by date of publication and/or edition number or version number) or non-specific.
- For a specific reference, subsequent revisions do not apply.
- For a non-specific reference, the latest version applies.

Referenced documents which are not found to be publicly available in the expected location might be found at <http://docbox.etsi.org/Reference>.

- [1] ETSI ES 282 001: "Telecommunications and Internet converged Services and Protocols for Advanced Networking (TISPAN); NGN Functional Architecture Release 1".
- [2] ETSI ES 282 003: "Telecommunications and Internet converged Services and Protocols for Advanced Networking (TISPAN); Resource and Admission Control Sub-system (RACS); Functional Architecture".
- [3] ETSI ES 282 004: "Telecommunications and Internet converged Services and Protocols for Advanced Networking (TISPAN); NGN Functional Architecture; Network Attachment Sub-System (NASS)".
- [4] ETSI ES 283 034: "Telecommunications and Internet converged Services and Protocols for Advanced Networks (TISPAN); Network Attachment Sub-System (NASS); e4 interface based on the DIAMETER protocol".
- [5] ETSI TS 183 017 "Telecommunications and Internet converged Services and Protocols for Advanced Networking (TISPAN);Resource and Admission Control: DIAMETER protocol for session based policy set-up information exchange between the Application Function (AF) and the Service Policy Decision Function (SPDF); Protocol specification".
- [6] ETSI TS 129 207: "Digital cellular telecommunications system (Phase 2+); Universal Mobile Telecommunications System (UMTS); Policy control over Go interface (3GPP TS 29.207)".

- [7] ETSI TS 129 209: "Universal Mobile Telecommunications System (UMTS); Policy control over Gq interface (3GPP TS 29.209)".
- [8] ETSI TS 133 210: "Digital cellular telecommunications system (Phase 2+); Universal Mobile Telecommunications System (UMTS); 3G security; Network Domain Security (NDS); IP network layer security (3GPP TS 33.210)".
- [9] IETF RFC 2960: "Stream Control Transmission Protocol".
- [10] IETF RCF 3309: "SCTP Checksum Change".
- [11] IETF RFC 3588: "Diameter Base Protocol".
- [12] IETF RFC 4005: "Diameter Network Access Server Application".

3 Definitions and abbreviations

3.1 Definitions

For the purposes of the present document, the following terms and definitions apply:

Attribute-Value Pair (AVP): See RFC 3588 [11], corresponds to an Information Element in a Diameter message.

hard-state reservation: type of reservation whereby the requested resources are reserved without time limit

NOTE: Hard-state reservations are terminated if the DIAMETER session is terminated.

soft-state reservation: type of reservation whereby the requested resources are reserved for a finite amount of time, soft-state reservations are terminated when the DIAMETER session is terminated

3.2 Abbreviations

For the purposes of the present document, the following abbreviations apply:

AAA	AA-Answer
AAR	AA-Request
AF	Application Function
A-RACF	Access-Resource and Admission Control Function
ASA	Abort-Session-Answer
ASR	Abort-Session-Request
ATM VC	Asynchronous Transfer Mode Virtual Circuit
AVP	Attribute-Value Pair
IANA	Internet Assigned Numbers Authority
IP-CAN	IP-Connectivity Access Network
NASREQ	Network Access Server REquirements
RAA	Re-Auth-Answer
RACF	Resource and Admission Control Function
RACS	Resource and Admission Control Subsystem
RAR	Re-Auth-Request
RCEF	Residual Code Excited Field
SPDF	Service-based Policy Decision Function
STA	Session-Termination-Answer
STR	Session-Termination-Request
xDSL	x Digital Subscriber Line

4 Rq interface

4.1 Overview

In the following, the Rq interface is described in detail concerning what type of information that needs to be transported between the SPDF and the A-RACF. The Rq reference point is used for resource reservation as defined in ES 282 003 [2]. Due to the possible business roles in an access environment, an SPDF instance may be either in the same domain or in a different domain as the A-RACF instance with which it interacts. This means that Rq reference point should support both the case when an SPDF instance and the A-RACF instance with which it interacts are located in the same domain, and when they are located in different domains.

The Rq reference point is an open vendor interface and an open operator interface. One A-RACF instance shall be able to serve more than one SPDF instance and one given SPDF instance may interact with a number of A-RACF instances, although on a session basis, it shall interact with only a single A-RACF instance.

4.2 Rq reference model

The Rq interface is defined between the SPDF and the A-RACF.

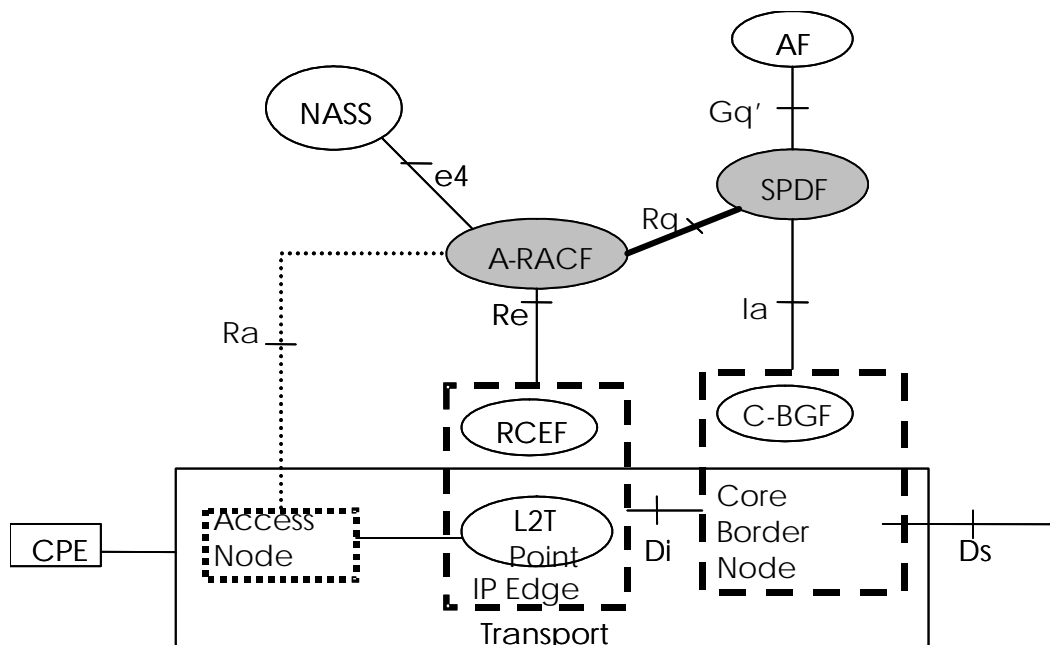

Figure 1: Rq interface architecture model

4.3 Functional elements and capabilities

4.3.1 Service Policy Decision Function (SPDF)

The SPDF is a functional element that coordinates the resource reservations requests received from by the AF. The SPDF makes policy decisions using policy rules and forwards the session and media related information obtained from the AF to the A-RACF via the Rq reference point for admission control purposes. The functionality of the SPDF is further detailed in ES 282 003 [2].

4.3.2 Access-Resource Admission Control Function (A-RACF)

The A-RACF is a functional element performing resource reservation admission control and network policy assembly. The A-RACF receives resource reservation requests from the SPDF via the Rq reference point. The functionality of the SPDF is further detailed in ES 282 003 [2].

5 Resource control procedures

The resource control procedures are defined in seven interaction procedures:

- 1) Reservation.
- 2) Commit.
- 3) Reservation and commit.
- 4) Refresh.
- 5) Modification.
- 6) Release.
- 7) Event notification.

These interactions are described in the following clauses. During the interactions Diameter AVPs are passed between the SPDF and the A-RACF.

Figure 2 describes the flow states as maintained by the A-RACF according to the procedures. Annex A provides a table further clarifying how states change at different events and actions taken by the A-RACF.

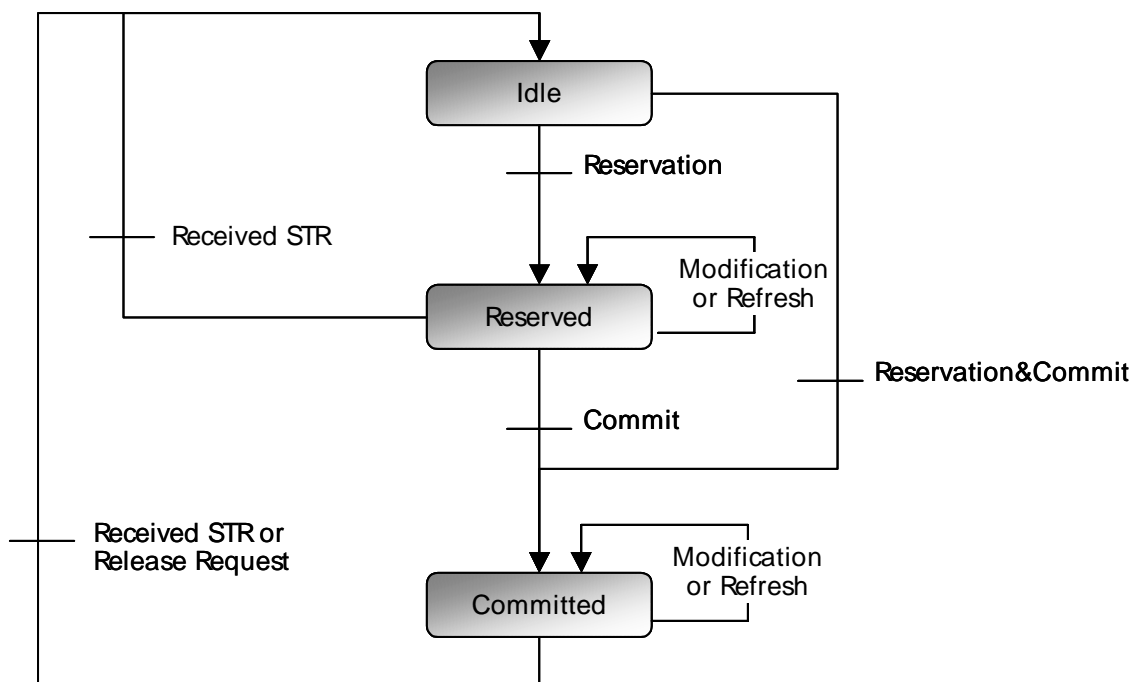

Figure 2: Flow state

The Flow-Status AVP (clause 6.4.11) is used to define the action to be taken for each AA-Request made by the SPDF to the A-RACF. The rules for interpreting the Flow-Status AVP are the following:

- **Reservation:** New Media-Description-Component AVP(s) and Media-Sub-Component AVP(s). Optional Flow-Status AVP(s) set to DISABLED (3).
- **Modification:** Updated Media-Description-Component AVP(s) and/or Media-Sub-Component AVP(s). Flow-Status AVP not modified, unless the state needs to be modified (e.g. for committing a resource reservation, or for releasing a resource reservation).
- **Commit:** Media-Description-Component AVP(s) and optionally Media-Sub-Component AVP(s) of existing reservations with Flow-Status AVP(s) set to ENABLED-UPLINK (0), ENABLED-DOWNLINK (1) or ENABLED (2).

- ReservationAndCommit: New Media-Component-Description AVP(s) and Media-Sub-Component AVP(s). Flow-Status AVP(s) set to ENABLED-UPLINK (0), ENABLED-DOWNLINK (1) or ENABLED (2).
- Release: Media-Description-Component AVP(s) and optionally Media-Sub-Component AVP(s) of existing reservations with Flow-Status AVP(s) set to REMOVED (4).
- Refresh: Existing reservation unchanged (Media-Component-Description AVP(s) not specified or unchanged), Flow-Status AVP unchanged.

5.1 Procedures at the SPDF

5.1.1 Initial Reservation for a Session

The SPDF may request the A-RACF to allocate resources for a new session (i.e. make an initial reservation request). The SPDF issues such request by sending an AA-Request message to the A-RACF. This message contains one or more Media-Component-Description Attribute-Value-Pair(s) (AVP(s)). Each Media-Component-Description AVP describes the set of flows of a particular media type (i.e. it contains one or more Media-Sub-Component AVP(s) and requirements for the flows (clause 6.4.16)).

The SPDF may in the AA-Request include the Flow-Grouping AVP(s) to request a particular way for how the IP Flows are to be distributed to IP-CAN bearers. The SPDF may also forward an AF-Charging-Identifier AVP from the AF in the message for charging correlation purposes between AF and RACS.

An AA-Request issued to request an initial reservation contains a new Session-Id obtained by the SPDF. As specified in RFC 3588 [11], the Session-Id is globally unique and is meant to uniquely identify a user session without reference to any other information. The Session-Id begins with the sender's identity encoded in the DiameterIdentity type.

The specific action that shall be performed by the A-RACF for each individual media and flow (i.e. the Reserve or the ReserveAndCommit operation) is defined by the Flow-Status AVP:

- Reservation; the value of the Flow-Status AVP shall be set to DISABLED (3).
- ReservationAndCommit; the value of the Flow-Status AVP shall be set to ENABLED-UPLINK (0), ENABLED-DOWNLINK (1) or ENABLED (2).
- The Flow-Status AVP shall be specified in the Media-Component-Description AVP and in the Media-Sub-Component AVP(s). The Flow-Status AVP shall be set to the same value in both these AVPs.

Table 1: Initial Reservation operations

Message Type	Flow-Status AVP at the level of:		Meaning
	Media	Sub-Media	
AAR	New Media, DISABLED	New flow, DISABLED	Reserve Resources for all the flows in the request. The media(s) and flow(s) descriptions MUST be new ones.
AAR	[New Media, ENABLE*]	New flow, ENABLE*	Reserve Resources. In addition, commit resources for some of the flows. The media(s) and flow(s) descriptions MUST be new ones.

As specified in clause 8.9 of RFC 3588 [11], the SPDF may specify the Authorization-Lifetime AVP in the AA-Request to request a maximum lifetime for a session. To request a hard-state session the SPDF shall omit the Authorization-Lifetime AVP in the AA-Request. To request a soft-state session the SPDF shall specify this AVP in the AA-Request and set its value to the preferred maximum lifetime of the session.

The AA-Answer may contain the Reservation-Lifetime AVP and the Auth-Grace-Period AVP defining a limited lifetime of the reservation whether or not the AA-Request contained a Authorization-Lifetime AVP. This means that the SPDF may be offered a soft-state reservation although it asked for hard-state or a hard-state reservation although it asked for soft-state. Should the SPDF not accept what is offered by the A-RACF it must explicitly terminate the session.

The SPDF may specify the Reservation-Priority AVP (clause 6.4.23) as a main AVP of the AA-Request in order to assign a priority to the request. The SPDF may further specify the Reservation-Priority AVP in Media-Component-Description AVP(s) in order to assign priority to individual media. If the Reservation-Priority AVP is not specified the requested priority is DEFAULT.

The SPDF may specify, in the Specific-Action AVP of the AA-Request through which the initial reservation request is made, the events of which it wants to be informed. The supported events are listed in clause 6.4.13.

Should the AA-Answer contain one or more Session-Bundle-Id AVPs the SPDF shall store the association between the Session-Bundle-Id AVP(s) and the Session-ID AVP of the session in question.

The behaviour when the SPDF does not receive an AA-Answer, or when it arrives after the internal timer waiting for it has expired, or when it arrives with an indication different than DIAMETER_SUCCESS, is outside the scope of the present document.

5.1.2 Session Modification

The SPDF may modify an existing session by sending an AA-Request to the A-RACF with one or more updated Media-Component-Description AVP(s) and/or Media-Sub-Component AVP(s). The Session-Id shall be an existing one and refer to the session that is to be modified. The Reservation-Priority may be specified as a main AVP and/or in Media-Component-Description AVP(s). If the Reservation-Priority AVP is not specified the requested priority is DEFAULT. The SPDF may perform the following operations:

- Add a new flow within a media component by providing a new Media-Sub-Component AVP within the corresponding Media-Component-Description AVP.
- Add a new flow within a new media component by providing a new Media-Component-Description AVP.
- Modify a media component by updating the corresponding Media-Component-Description AVP (e.g. increase or decrease the allocated bandwidth).
- Modify a flow within a media component by updating the corresponding Media-Sub-Component AVP.
- Modify a media flow state from Reserved to Committed by providing a Flow-Status AVP of the corresponding Media-Component-Description AVP and/or Media-Sub-Component AVP(s). The Flow-Status AVP shall be set to one of the values ENABLED-UPLINK, ENABLED-DOWNLINK or ENABLED, according to the direction in which the resources are to be committed. This operation requires that the media and flows are in the Reserved state prior to the AA-Request.
- Release a media component by providing the corresponding Media-Component-Description AVP with the Flow-Status AVP set to the value REMOVED.
- Release a flow within a media by providing the corresponding Media-Sub-Component AVP with the Flow-Status AVP set to the value REMOVED.
- Refresh a soft-state session by providing an AA-Request message containing the Session-Id of the session that is to be refreshed. The AA-Request may contain the Authorization-Lifetime AVP to request a maximum lifetime of the refreshed session. If this AVP is not included, the refresh message requests the lifetime to be extended by a default value. The AA-Request may contain Media-Component-Description AVP(s) and Media-Sub-Component AVP(s) (e.g. to modify media, flows and/or commit status).

The Flow-Status AVP in the Media-Sub-Component AVP shall always be the same as the Flow-Status AVP in the Media-Component-Description AVP containing the Media-Sub-Component AVP. When providing new Media-Component-Description AVP(s) and/or Media-Sub-Component AVP(s) the SPDF may in the AA-Request include the Flow-Grouping AVP(s) to request a particular way for how the IP Flows are to be distributed to IP-CAN bearers.

Table 2: Modification operations

Message Type	Flow-Status AVP at the level of:		Meaning
	Media	Sub-Media	
AAR	Existing Media	Existing Flow, Unchanged Flow-Status	Modify a media. In addition, modify a flow according to the new parameters specified in the Media-Sub-Component AVP. The Media and Flow must exist (see notes 1, 2 and 5).
AAR	Existing Media	New flow. Same Flow-Status AVP as in the media. (see note 3)	Modify a media. In addition, add a new flow in a media. The Flow must be new (see notes 3 and 5).
AAR	Existing Media (see note 4)	REMOVED	Modify a media. In addition, release an existing flow within an existing media. If the flow does not exist, the request shall be ignored by the A-RACF (see notes 2 and 5).
AAR	Existing Media, Modified Flow-Status	Existing Flow, Flow-Status AVP = REMOVED	Modify the commit status (see note 5).
AAR	Existing Media	Existing Flow	(see note 5).
NOTE 1: If the media is not an existing one, the AAR is interpreted as a reservation for a new media (clause 5.1).			
NOTE 2: The parameters specified at flow-level (in the Media-Sub-Component AVP(s)) take precedence over the parameters specified at media-level (in the updated Media-Component-Description AVP).			
NOTE 3: The Flow-Status AVP of a new flow within a media shall be the same as the Flow-Status of the media. For example, it makes no sense to commit a flow within a media that is not yet committed.			
NOTE 4: As the Modify operation is also used for the Commit operation, the Flow-Status AVP of the Media-Component-Description AVP may actually be modified.			
NOTE 5: In case of a soft-state reservation, extend its lifetime.			

The behaviour when the SPDF does not receive an AA-Answer, or when it arrives after the internal timer waiting for it has expired, or when it arrives with an indication different than DIAMETER_SUCCESS, is outside the scope of the present document.

5.1.3 Session Termination

The SPDF may issue a Session-Termination-Request (STR) command to the A-RACF, in order to terminate the session. This command releases all the resources associated with the session identified by the provided Session-Id AVP.

Table 3: Termination operations

Message Type	Flow-Status AVP at the level of:		Meaning
	Media	Sub-Media	
STR			Release a session: all the media(s) and flow(s) within that session are released

When receiving an Abort-Session-Request (ASR) message from the A-RACF the SPDF shall if the session involves BGF resources release those resources and inform the AF of that the session identified by the Session-Id AVP is terminated. If the ASR message contains one or more Session-Bundle-Id AVPs the SPDF shall perform these procedures for all sessions associated with the Session-Bundle-Id AVP(s).

5.1.4 Event notification

Notifications for specific events may be implicitly requested through policies established in the A-RACF. The SPDF may further specify, in the Specific-Action AVP of an initial AA-Request command, the events of which it wants to be informed. The supported events are listed in clause 6.4.

5.2 Procedures at the A-RACF

5.2.1 Initial Reservation for a Session

An initial AA-Request contains one or more Media-Component-Description AVP(s) including one or more Media-Sub-Component AVP(s). For initial reservation requests in which the Session-Id is new the Media-Component-Number(s) and Flow-Number(s) are interpreted by the A-RACF as new ones.

The Reservation-Priority AVP may be specified (clause 6.4.23) main AVP in the AA-Request. The AA-Answer from the A-RACF may echo the Reservation-Priority AVP. If the Reservation-Priority AVP is not specified in the AA-Request, the priority associated with the reservation shall be DEFAULT. If the A-RACF is not able to comply with the requested priority level, the entire reservation shall fail and the A-RACF shall include the Experimental-Result-Code AVP with the value PRIORITY_NOT_GRANTED.

When provided as a main AVP in an AA-Request, the Reservation-Priority AVP indicates the priority of the message to the A-RACF. The A-RACF may use this indication when receiving and processing the message (e.g. high priority AA-Request messages may be assigned precedence over low priority AA-Request messages).

Upon reception of an AF-Application-Identifier AVP in an initial AA-Request from the SPDF, the A-RACF shall store this identifier together with the states created and maintained for the new session for the purpose of charging correlation between AF and RACS. The identifier is opaque to the A-RACF.

The A-RACF shall identify the access profile that applies to the AA-Request from an identifier. This identifier comes in the form of the Subscriber ID, the Globally Unique IP Address, or both (clause 5.2.2.2.7 in ES 282 003 [2]). The mapping of these parameters to the Diameter AVPs is described in table 4. If the A-RACF does not receive at least one of these parameters, it shall return an AA-Answer that include a Result-Code AVP set to the value DIAMETER_MISSING_AVP. The Failed-AVP AVP should be included in the message. The Failed-AVP AVP must contain an example of the missing AVP. The value field of the missing AVP example should be of correct minimum length and contain zeroes.

If the A-RACF cannot identify an access profile that applies to the AA-Request, it shall return an Experimental-Result-Code AVP to the SPDF set to ACCESS_PROFILE_FAILURE.

Table 4: Mapping of information element names to Diameter AVPs

Information element name	Mapping to Diameter AVP	Cat.	AVP used in
Subscriber ID in RACS [2] and in NASS [3]	User-Name	O	Rq and e4 [4]
Globally Unique IP Address in RACS [2] and in NASS [3]	Globally-Unique-Address	O	Rq and e4 [4]
QoS Profile in NASS [3]	QoS-Profile	O	e4 [4]
Requestor Name in RACS [2]	AF-Application-Identifier	O	Rq
Requestor Name in NASS [3]	Application-Class-ID	O	e4 [4]
Media Type in NASS [3] and in RACS [2]	Media-Type	O	Rq and e4 [4]
Reservation Class in RACS [2]	Reservation-Class	O	Rq
Transport Service Class in RACS [2]	Reservation-Class	O	Rq
Transport Service Class in NASS [3]	Transport-Class	O	e4 [4]

If the identified access profile contains one or more QoS Profiles the A-RACF shall for each Media-Component-Description AVP in the AA-Request use the combined meaning of the AF-Application-Identifier AVP, the Reservation-Class AVP and the Media-Type AVP to identify a QoS Profile to which the request applies. For this identification process the Reservation-Class AVP received over Rq shall via a local mapping table in the A-RACF be matched with the information stored in the A-RACF that corresponds to the Transport-Class AVP(s) in the QoS Profile(s) obtained from NASS via e4 ES 283 034 [4]. The AF-Application-Identifier AVP and the Media-Type AVP in the AA-Request received over Rq shall further be matched with the information stored in the A-RACF that corresponds to the Application-Class-ID AVP and the Media-Type AVP(s) respectively in the QoS Profile(s) obtained from NASS via e4 ES 283 034 [4].

It should be noted that an access profile obtained from NASS via e4 ES 283 034 [4] may contain one or more QoS Profile AVPs with left out Application-Class-ID AVP, Transport-Class AVP and/or Media-Type AVP. The absence of these AVPs allows the A-RACF to apply default QoS Profiles to any Requestor Name, any Transport Service Class, and any Requestor Name and Transport Service Class.

If the access profile does not contain any QoS Profile the A-RACF shall instead apply a default QoS Profile to the request. If the Reservation-Priority AVP is not specified in the Media-Component-Description AVP for which a QoS profile applies the requested priority is DEFAULT.

The A-RACF shall return an Experimental-Result-Code AVP to the SPDF set to QOS_PROFILE_FAILURE if the request needs to be denied for any of the following reasons:

- The User-Name AVP and/or the Globally-Unique-Address AVP do not match any access profile.
- The AF-Application-Identifier AVP, Reservation-Class AVP and Media-Type AVP do not match any QoS profile of the access profile (identified by the User-Name AVP and/or the Globally-Unique-Address AVP).
- The Max-Requested-Bandwidth-UL AVP and/or the Max-Requested-Bandwidth-DL AVP are larger than what is allowed by the QoS Profile matching the request (i.e. the Maximum-Allowed-Bandwidth-UL AVP and/or the Maximum-Allowed-Bandwidth-DL AVP obtained via e4).
- The Reservation-Priority AVP in the Media-Component-Description AVP is larger than the maximum priority allowed by the QoS profile matching the request (i.e. the Maximum-Priority AVP obtained via e4).

Note that only the first failure reason is possible for access profiles that do not contain a QoS Profile.

Any value of the Flow-Status AVP received in an initial AA-Request (in which the Session-Id is new) different from ENABLED-UPLINK, ENABLED-DOWNLINK, ENABLED or DISABLED shall result in an error. If the Flow-Status AVP has the value REMOVED the A-RACF shall return an AA-Answer containing a Failed-AVP AVP and a Result-Code AVP with the value DIAMETER_INVALID_AVP_VALUE.

In case the operation fails due to lack of resources, the A-RACF shall include the Experimental-Result-Code AVP set to the value INSUFFICIENT_RESOURCES.

An initial reservation request can be admitted by the A-RACF if for all media streams in the session, the resource requirements fit within the constraints of remaining envelopes of unused resources. The A-RACF is presumed to exhibit "atomic" reservation semantics (i.e. either all reservations are admitted, or none of them). Once a reservation is admitted, the corresponding amount of resources is removed from the pool of available resources.

If the request is admitted the A-RACF must send an AA-Answer back to the SPDF and include the Result-Code AVP set to the value DIAMETER_SUCCESS.

Upon successful reservation, the A-RACF shall store the Diameter base protocol Session-Id received in the AA-Request through which the initial reservation request was made, and the Media-Component-Number(s) and Flow-Number(s). It shall also create an instance of the state machine illustrated in figure 2 for each media in the session and store the state of each media of the session.

The AA-Request may contain the Authorization-Lifetime AVP. The A-RACF shall interpret the presence of the Authorization-Lifetime AVP as a request for a soft-state reservation and the absence of this AVP as a request for a hard-state reservation. The A-RACF may however return the Reservation-Lifetime AVP and the Auth-Grace-Period AVP defining a limited lifetime of the reservation although the AA-Request did not contain the Authorization-Lifetime AVP. The A-RACF thereby offers a soft-state reservation although the request was for hard-state. The A-RACF may also choose not to return the Reservation-Lifetime AVP and the Auth-Grace-Period AVP although the AA-Request contained the Authorization-Lifetime AVP. The A-RACF thereby offers a hard-state reservation although the request was for soft-state reservation.

As specified in clause 8.9 of RFC 3588 [11] the server (i.e. the A-RACF) may return the Reservation-Lifetime AVP and the Auth-Grace-Period AVP set to values for which the sum is equal to, or smaller, than the value of the Authorization-Lifetime AVP provided by the SPDF.

The A-RACF may include one or more Session-Bundle-Id AVPs in the AA-Answer. The Session-Bundle-Id AVP identifies a group of sessions to which the session belongs. The value of this AVP and which sessions that belong to a certain such value are chosen by the A-RACF. The value if the Session-Bundle-Id AVP is meaningful only for the A-RACF.

If the Specific-Action AVP is included in the initial AA-Request, notification for the given event(s) shall be activated by the A-RACF. The supported events are listed in clause 6.

5.2.2 Session Modification

An AA-Request issued to modify an existing session contains one or more Media-Component-Description AVP(s) including one or more Media-Sub-Component AVP(s). For modification requests in which the Session-Id is an existing one the Media-Component-Number(s) and Flow-Number(s) of existing reservations shall be existing ones. Media-Component-Number(s) and Flow-Number(s) of new Media-Component-Description AVP(s) and Media-Sub-Component AVP(s) are interpreted by the A-RACF as new ones.

For an AA-Request issuing a session modification operation the Flow-Status AVP must be set to a value representing a state to which the session is allowed to enter from its current state. The allowed state transitions are illustrated in figure 2. Should the Flow-Status AVP be set to a disallowed value the A-RACF shall return an AA-Answer containing a Failed-AVP AVP and a Result-Code AVP with the value `DIAMETER_INVALID_AVP_VALUE`.

If the A-RACF is unable to modify the commit status of a reservation, the A-RACF shall issue an error message to the SPDF with an Experimental-Result-Code AVP set to the value `COMMIT_FAILURE`. If the status of a reservation is one of the values `ENABLED-UPLINK`, `ENABLED-DOWNLINK` or `ENABLED`, the AA-Request should not contain a Flow-Status AVP set to `REMOVED`. If it does, the A-RACF shall return an AA-Answer to the SPDF with an Experimental-Result-Code AVP set to the value `MODIFICATION_FAILURE`. If the A-RACF is not able to re-initialize the lifetime of the reservation, it shall return an AA-Answer to the SPDF with an Experimental-Result-Code AVP set to the value `REFRESH_FAILURE`.

If a flow-level operation fails, the entire Session Modification operation fails. In case the A-RACF determines that the request cannot be admitted due to insufficient resources, it shall return an Experimental-Result-Code AVP to the SPDF set to the value `INSUFFICIENT_RESOURCES`. The A-RACF shall return an Experimental-Result-Code AVP to the SPDF set to `QOS_PROFILE_FAILURE` if the request needs to be denied for any of the reasons listed in clause 5.2.1 associated with this value.

Upon successful session modification, the A-RACF must send an AA-Answer back to the SPDF with the Result-Code AVP set to `DIAMETER_SUCCESS`.

Upon a successful refresh operation, the A-RACF shall in the AA-Answer return the Reservation-Lifetime AVP and the Auth-Grace-Period AVP in which a lifetime equal or less than what was defined by the Authorization-Lifetime AVP of the AA-Request. Should the Authorization-Lifetime AVP not be included the A-RACF shall return the Reservation-Lifetime AVP and the Auth-Grace-Period AVP in which a limited lifetime is defined in the AA-Answer.

If a reference to a previously negotiated Media-Component-Description AVP and/or Media-Sub-Component AVP for the session in question is omitted in the AA-Request, the corresponding flow is not impacted by the Modification operation.

5.2.3 Session Termination

If all IP flows within a SPDF session need to be terminated, the A-RACF shall inform the SPDF about this event by sending an Abort-Session-Request (ASR) message with the appropriate Abort-Cause AVP value. The A-RACF may include one or more Session-Bundle-Id AVPs in order to inform the SPDF of that several sessions identified by the provided Session-Bundle-Id AVP(s) are terminated.

Upon receipt of a Session-Termination-Request (STR) message from the SPDF the A-RACF shall release all the resources associated with the session identified through the provided Session-Id AVP. If an unknown Session-Id is provided in the STR the A-RACF shall return a STA message to the SPDF with the Result-Code AVP set to `DIAMETER_UNKNOWN_SESSION_ID`.

5.2.4 Event Notification

If an event for which notification is requested occurs, the A-RACF shall send an unsolicited RAR message to the SPDF containing:

- The value of the Specific-Action AVP, indicating the event that occurred.
- Optionally, the appropriate Abort-Cause AVP value.

6. Rq protocol

The Rq protocol is based on Diameter (RFC 3588 [11]).

6.1 Protocol support

The Diameter Base Protocol as specified in RFC 3588 [11] used to support information transfer on the Rq interface. RFC 3588 [11] shall apply except as modified by the defined Rq application specific procedures, Attribute-Value-Pairs (AVPs) as well as Experimental-Result-Code AVP and Specific-Action AVP values defined in the present document. Unless otherwise specified, the procedures of RFC 3588 [11] (including error handling and unrecognized information handling) are unmodified. In addition to the AVPs defined in clause 6.4, the Diameter AVPs from the Diameter base application (RFC 3588 [11]) are reused within the Diameter messages sent over the Rq reference point.

The support of AVPs from the Diameter Network Access Server Application (NASREQ) (RFC 4005 [12]) is not required from Diameter implementations that conform to the present document. Accounting functionality (Accounting Session State Machine, related command codes and AVPs) is not used in the Rq specification re-uses the Diameter application defined for the 3GPP Gq interface (TS 129 209 [7]). The Gq Diameter application is defined as an IETF vendor specific Diameter application with Application-ID 16777222. The vendor identifier assigned by IANA to 3GPP is 10415 and the vendor identifier assigned by IANA to ETSI is 13019. The Vendor-Id header for AVPs imported from TS 129 209 [7] shall be set to 3GPP (19415), while AVPs defined in the present document or imported from TS 183 017 [5] or ES 283 034 [4] shall be set to ETSI (13019).

With regard to the Diameter protocol defined over the Rq reference point, the A-RACF acts as a Diameter server, in the sense that it is the network element that handles authorization requests for a particular realm. The SPDF acts as the Diameter Client, in the sense that is the network element requesting authorization to use bearer path network resources.

The support of Diameter agents between the A-RACF and the SPDF, is optional where the Rq is intra operator i.e. A-RACF and SPDF are all in the same domain.

6.1.1 Advertising Application Support

The Capabilities-Exchange-Request (CER) and Capabilities-Exchange-Answer (CEA) commands are specified in the Diameter Base Protocol RFC 3588 [11].

Due to the definition of the commands used over the Rq reference point, the Vendor-Specific-Application-Id AVP cannot be used instead of the Auth-Application-Id AVP. Therefore the Gq application identifier shall be included in the Auth-Application-Id AVP.

Additionally, the SPDF and the A-RACF shall advertise the support of additional Vendor-ID AVPs by including the value 13019 (ETSI) and 10415 (3GPP) in two different Supported-Vendor-Id AVPs of the CER and CEA commands.

6.1.2 Transport protocol

Diameter messages over the Rq reference point shall make use of SCTP RFC 2960 [9] and shall utilize the new SCTP checksum method specified in RFC 3309 [10].

6.1.3 Securing Rq messages

For secure transport of Diameter messages, see TS 133 210 [8].

6.2 Rq messages

Existing Diameter command codes from the Diameter base protocol RFC 3588 [11] and the NASREQ Diameter application RFC 4005 [12] are used at the Rq interface. The Application-ID of 16777222 is used together with the command code to identify the Rq messages.

6.2.1 AA-Request (AAR) Command

The AA-Request command (AAR), indicated by the Command-Code field set to 265 and the "R" bit set in the Command Flags field, is sent by the SPDF to the A-RACF for reserve, commit, modify, release and refresh operations.

Message Format:

```
<AA-Request> ::= < Diameter Header: 265, REQ, PXY >
  < Session-Id >
  { Auth-Application-ID }
  { Origin-Host }
  { Origin-Realm }
  { Destination-Realm }
  [ AF-Charging-Identifier ]
  * [ Media-Component-Description ]
  * [ Flow-Grouping ]
  [ Reservation-Priority ]
  [ User-Name ]
  [ Globally-Unique-Address ]
  [ Address-Realm ]
  [ Authorization-Lifetime ]
  * [ Proxy-Info ]
  * [ Route-Record ]
  * [ AVP ]
```

6.2.2 AA-Answer (AAA) Command

The AA-Answer command (AAA), indicated by the Command-Code field set to 265 and the "R" bit cleared in the Command Flags field, is sent by the RACF to the SDPF in response to the AAR command. The A-RACF may confirm the priority associated with the reservation by echoing the Reservation-Priority AVP (clause 6.4.23).

Message Format:

```
<AA-Answer> ::= < Diameter Header: 265, PXY >
  < Session-Id >
  { Auth-Application-ID }
  { Origin-Host }
  { Origin-Realm }
  [ Result-Code ]
  [ Experimental-Result ]
  [ Error-Message ]
  [ Error-Reporting-Host ]
  [ Auth-Grace-Period ]
  * [ Session-Bundle-Id ]
  [ Reservation-Priority ]
  [ Authorization-Lifetime ]
  * [ Failed-AVP ]
  * [ Proxy-Info ]
  * [ AVP ]
```

6.2.3 Re-Auth-Request (RAR) Command

The RAR command, indicated by the Command-Code field set to 258 and the "R" bit set in the Command Flags field, is sent by the A-RACF to the SPDF in order to indicate a specific action.

As an option, the SPDF may send an AAR command to the A-RACF to update the service information when receiving an RAA command. However, application-specific authentication and/or authorization messages are not mandated for the Rq application in response to an RAR command.

The values INDICATION_OF_RELEASE_OF_BEARER, INDICATION_OF_SUBSCRIBER_DETACHMENT and INDICATION_OF_RESERVATION_EXPIRATION of the Specific-Action AVP shall not be combined with each other in a Re-Auth-Request.

Message Format:

```
<RA-Request> ::= < Diameter Header: 258, REQ, PXY >
    < Session-Id >
    { Origin-Host }
    { Origin-Realm }
    { Destination-Realm }
    { Destination-Host }
    { Auth-Application-Id }
    *{ Specific-Action }
    *[ Flows ]
    [ Abort-Cause ]
    [ Origin-State-Id ]
    *[ Proxy-Info ]
    *[ Route-Record ]
    *[ AVP ]
```

6.2.4 Re-Auth-Answer (RAA) Command

The RAA command, indicated by the Command-Code field set to 258 and the "R" bit cleared in the Command Flags field, is sent by the SPDF to the A-RACF in response to the RAR command.

Message Format:

```
<RA-Answer> ::= < Diameter Header: 258, PXY >
    < Session-Id >
    { Origin-Host }
    { Origin-Realm }
    [ Result-Code ]
    [ Experimental-Result ]
    *{ Media-Component-Description }
    *{ Flow-Grouping }
    [ Origin-State-Id ]
    [ Error-Message ]
    [ Error-Reporting-Host ]
    *[ Failed-AVP ]
    *[ Proxy-Info ]
    *[ AVP ]
```

6.2.5 Session-Termination-Request (STR) Command

The STR command, indicated by the Command-Code field set to 275 and the "R" bit set in the Command Flags field, is sent by the SPDF to inform the A-RACF that an authorized session shall be terminated.

Message Format:

```
<ST-Request> ::= < Diameter Header: 275, REQ, PXY >
    < Session-Id >
    { Origin-Host }
    { Origin-Realm }
    { Destination-Realm }
    { Auth-Application-ID }
    { Termination-Cause }
    { Destination-Host }
    [ Class ]
    [ Origin-State-Id ]
    *[ Proxy-Info ]
    *[ Route-Record ]
    *[ AVP ]
```

6.2.6 Session-Termination-Answer (STA) Command

The STA command, indicated by the Command-Code field set to 275 and the "R" bit cleared in the Command Flags field, is sent by the A-RACF to the SPDF in response to the STR command.

Message Format:

```
<ST-Answer> ::= < Diameter Header: 275, PXY >
< Session-Id >
{ Origin-Host }
{ Origin-Realm }
{ Auth-Application-ID }
[ Result-Code ]
[ Experimental-Result ]
[ Error-Message ]
[ Error-Reporting-Host ]
*[ Failed-AVP ]
[ Origin-State-Id ]
*[ Redirect-Host ]
[ Redirect-Host-Usage ]
[ Redirect-Max-Cache-Time ]
*[ Proxy-Info ]
[ AVP ]
```

6.2.7 Abort-Session-Request (ASR) Command

The ASR command, indicated by the Command-Code field set to 274 and the "R" bit set in the Command Flags field, is sent by the A-RACF to inform the SPDF that all resources for the authorized session have become unavailable.

Message Format:

```
<AS-Request> ::= < Diameter Header: 274, REQ, PXY >
< Session-Id >
{ Origin-Host }
{ Origin-Realm }
{ Destination-Realm }
{ Destination-Host }
{ Auth-Application-ID }
{ Abort-Cause }
*[ Session-Bundle-Id ]
[ Origin-State-Id ]
*[ Proxy-Info ]
*[ Route-Record ]
[ AVP ]
```

6.2.8 Abort-Session-Answer (ASA) Command

The ASA command, indicated by the Command-Code field set to 274 and the "R" bit cleared in the Command Flags field, is sent by the SPDF to the A-RACF in response to the ASR command.

Message Format:

```
<AS-Answer> ::= < Diameter Header: 274, PXY >
< Session-Id >
{ Origin-Host }
{ Origin-Realm }
[ Result-Code ]
[ Experimental-Result ]
[ Origin-State-Id ]
[ Error-Message ]
[ Error-Reporting-Host ]
*[ Failed-AVP ]
*[ Redirected-Host ]
[ Redirected-Host-Usage ]
[ Redirected-Max-Cache-Time ]
*[ Proxy-Info ]
*[ AVP ]
```

6.3 Experimental-Result-Code AVP values

6.3.1 Experimental-Result-Code AVP values imported from TS 129 209

The present document reuses existing Experimental-Result-Code AVP values defined in TS 129 209 [7]. This clause defines the specific values of the Experimental-Result-Code AVP:

INVALID_SERVICE_INFORMATION (5061)

The service information provided by the AF is invalid or insufficient for the server to perform the requested action.

FILTER_RESTRICTIONS (5062)

The Flow-Description AVP(s) cannot be handled by the server because restrictions defined in clause 6.4.7 are not observed.

6.3.2 Experimental-Result-Code AVP values defined in the present document

This clause defines the specific values of the Experimental-Result-Code AVP (vendor-id is ETSI):

INSUFFICIENT_RESOURCES (4041).

The A-RACF indicates insufficient resources to perform the requested action.

MODIFICATION_FAILURE (5041).

The A-RACF or BGF indicates that the resources reservation could not be modified. This is a permanent failure.

COMMIT_FAILURE (4043).

The A-RACF indicates that the resources reservation could not be committed.

REFRESH_FAILURE (4044).

The A-RACF indicates that the lifetime of a reservation could not be extended.

QOS_PROFILE_FAILURE (4045).

The A-RACF indicates that the request did not match the QoS profile.

ACCESS_PROFILE_FAILURE (4046).

The A-RACF indicates that the request did not match any access profile.

PRIORITY_NOT_GRANTED (4047).

The A-RACF indicates that the priority level of the request is not accepted.

6.4 AVPs

This clause summarizes the AVPs used in the present document, beyond those defined in the Diameter Base Protocol.

6.4.1 AVPs defined in the present document

The following table describes the Diameter AVPs defined in the present document, their AVP Code values, types, possible flag values and whether the AVP may be encrypted. The vendor-Id header of all AVPs defined in the present document shall be set to ETSI (13019).

Table 5: Diameter AVPs defined in the present document

Attribute Name	AVP Code	Clause defined	Value Type (see note 2)	AVP Flag rules (see note 1)				May Encr.
				Must	May	Should not	Must not	
Session-Bundle-Id	400	0	Unsigned32	M,V	P			Y
NOTE 1: The AVP header bit denoted as "M", indicates whether support of the AVP is required. The AVP header bit denoted as "V", indicates whether the optional Vendor-ID field is present in the AVP header. For further details, see RFC 3588 [11].								
NOTE 2: The value types are defined in RFC 3588 [11].								

6.4.2 AVPs imported from TS 129 209

The present document reuses existing AVP(s) used already at the Gq interface TS 129 209 [7]. Not all the AVPs defined in TS 129 209 [7] are reused (e.g. Access-Network-Charging-Identifier-Value AVP).

The following table describes the Diameter AVPs defined for the Gq interface protocol [7] and used in the present document, their AVP Code values, types, possible flag values and whether the AVP may be encrypted. Flags values are described in the context of the present document rather than in the context of the application where they are defined. AVPs defined in TS 129 209 [7] but not listed in the following table should not be sent by Diameter implementations conforming to the present document and shall be ignored by receiving entities. The Vendor-Id header for these AVPs shall be set to 3GPP (10415).

Table 6: Diameter AVPs imported from TS 129 209 [7]

Attribute Name	AVP Code	Clause defined	Value Type (See note 2)	AVP Flag rules (See note 1)				May Encr.
				Must	May	Should not	Must not	
Abort-Cause	500	6.4.5	Enumerated	M,V	P			Y
AF-Application-Identifier	504	6.4.6	OctetString	M,V	P			Y
AF-Charging-Identifier	505	6.4.25	OctetString	M,V	P			Y
Flow-Description	507	6.4.7	IPFilterRule	M,V	P			Y
Flow-Grouping	508	6.4.8	Grouped	M,V	P			Y
Flow-Number	509	6.4.9	Unsigned32	M,V	P			Y
Flows	510	6.4.10	Grouped	M,V	P			Y
Flow-Status	511	6.4.11	Enumerated	M,V	P			Y
Flow-Usage	512	6.4.12	Enumerated	M,V	P			Y
Specific-Action	513	6.4.13	Enumerated	M,V	P			Y
Max-Requested-Bandwidth-DL	515	6.4.14	Unsigned32	M,V	P			Y
Max-Requested-Bandwidth-UL	516	6.4.15	Unsigned32	M,V	P			Y
Media-Component-Description	517	6.4.16	Grouped	M,V	P			Y
Media-Component-Number	518	6.4.17	Unsigned32	M,V	P			Y
Media-Sub-Component AVP	519	6.4.18	Grouped	M,V	P			Y
Media-Type	520	6.4.19	Enumerated	M,V	P			Y
NOTE 1: The AVP header bit denoted as "M", indicates whether support of the AVP is required. The AVP header bit denoted as "V", indicates whether the optional Vendor-ID field is present in the AVP header. For further details, see RFC 3588 [11].								
NOTE 2: The value types are defined in RFC 3588 [11].								

6.4.3 AVPs imported from TS 183 017

The following table describes the Diameter AVPs defined for the Gq' interface protocol [5] and used in the present document, their AVP Code values, types, possible flag values and whether the AVP may be encrypted. Flags values are described in the context of the present document rather than in the context of the application where they are defined. AVPs defined in [5] but not listed in the following table should not be sent by Diameter implementations conforming to the present document and shall be ignored by receiving entities. The Vendor-Id header for these AVPs shall be set to ETSI (13019).

Table 7: Diameter AVPs imported from [5]

Attribute Name	AVP Code	Clause defined	Value Type (See note 2)	AVP Flag rules (See note 1)				May Encr.
				Must	May	Should not	Must not	
Reservation-Class	456	6.4.20	Unsigned32	M, V	P			Y
Reservation-Priority	458	6.4.23	Enumerated					
NOTE 1: The AVP header bit denoted as "M", indicates whether support of the AVP is required. The AVP header bit denoted as "V", indicates whether the optional Vendor-ID field is present in the AVP header. For further details, see RFC 3588 [11].								
NOTE 2: The value types are defined in RFC 3588 [11].								

6.4.4 AVPs imported from ES 283 034

The following table describes the Diameter AVPs defined for the e4 interface protocol [4] and used in the present document, their AVP Code values, types, possible flag values and whether the AVP may be encrypted. Flags values are described in the context of the present document rather than in the context of the application where they are defined. AVPs defined in [4] but not listed in the following table should not be sent by Diameter implementations conforming to the present document and shall be ignored by receiving entities. The Vendor-Id header for these AVPs shall be set to ETSI (13019).

Table 8: Diameter AVPs imported from [4]

Attribute Name	AVP Code	Clause defined	Value Type (NOTE 2)	AVP Flag rules (See note 1)				May Encr.
				Must	May	Should not	Must not	
Globally-Unique-Address	300	6.4.21	Grouped	M, V				Y
Address-Realm	301	6.4.22	OctetString	M, V				Y
NOTE 1: The AVP header bit denoted as "M", indicates whether support of the AVP is required. The AVP header bit denoted as "V", indicates whether the optional Vendor-ID field is present in the AVP header. For further details, see RFC 3588 [11].								
NOTE 2: The value types are defined in RFC 3588 [11].								

6.4.5 Abort-Cause AVP

The Abort-Cause AVP (AVP code 500) is of type Enumerated, and it determines the cause of an ASR. The following values defined in [7] are used:

BEARER_RELEASED (0)

This value is used when the bearer has been deactivated as a result from normal signalling handling. For xDSL, the bearer may refer to an ATM VC.

INSUFFICIENT_SERVER_RESOURCES (1)

This value is used to indicate that the A-RACF is overloaded and needs to abort the session.

INSUFFICIENT_BEARER_RESOURCES (2)

This value is used when the bearer has been deactivated due to insufficient bearer resources at a transport gateway (e.g. RCEF for xDSL).

6.4.6 AF-Application-Identifier AVP

The AF-Application-Identifier AVP (AVP code 504) is of type OctetString, and contains information that identifies the particular service to which the session belongs. This information may be used by the A-RACF to differentiate QoS for different application services. For example the AF-Application-Identifier may be used as additional information together with the Media-Type AVP. The AF-Application-Identifier may also be used to complete the reservation with application specific default settings in the A-RACF if the SPDF does not provide the full Session-Component-Description information.

6.4.7 Flow-Description AVP

- The Flow-Description AVP (AVP code 507) is of type IPFilterRule, and defines a packet filter for an IP flow with the following information: Direction (in or out).
- Source and destination IP address (possibly masked).
- Protocol.
- Source and destination port (list or ranges).

The IPFilterRule type shall be used with the following restrictions:

- Only the Action "permit" shall be used.
- No "options" shall be used.
- The invert modifier "!" for addresses shall not be used.
- The keyword "assigned" shall not be used.

If any of these restrictions is not observed by the AF, the server shall send an error response to the AF containing the Experimental-Result-Code AVP with value FILTER_RESTRICTIONS.

The Flow description AVP shall be used to describe a single IP flow.

The direction "in" refers to uplink IP flows, and the direction "out" refers to downlink IP flows.

6.4.8 Flow-Grouping AVP

The Flow-Grouping AVP (AVP code 508) is of type Grouped, and it indicates that no other IP Flows shall be transported together with the listed IP Flows in the same IP-CAN bearer.

If Flow-Grouping AVP(s) have been provided in earlier service information, but are not provided in subsequent service information, the old flow grouping remains valid.

If Flow-Grouping AVP(s) have been provided in earlier service information, and new Flow-Grouping AVP(s) are provided, the new flow grouping information replaces the previous information. Previous flow grouping information is invalidated even if the new Flow-Grouping AVP(s) affect other IP flows.

A Flow-Grouping AVP containing no Flows AVP may be used to invalidate flow grouping information provided in earlier service information. A Flow-Grouping AVP containing no Flows AVP shall not be supplied together with other Flow-Grouping AVP(s).

If earlier service information has already been provided, flow grouping information in subsequent service information shall not restrict the flow grouping further for IP flows already described in the previous service information. However, new IP flows described for the first time in the subsequent service information may be added to existing flow groups or in new flow groups.

AVP Format:

```
Flow-Grouping ::= < AVP Header: 508 >
                *[Flows]
```

6.4.9 Flow-Number AVP

The Flow-Number AVP (AVP code 509) is of type Unsigned32, and it contains the ordinal number of the IP flow(s), assigned according to the rules in annex C of TS 129 207 [6].

6.4.10 Flows AVP

The Flows AVP (AVP code 510) is of type Grouped, and it indicates IP flows via their flow identifiers. If no Flow-Number AVP(s) are supplied, the Flows AVP refers to all Flows matching the media component number.

AVP Format:

```
Flows ::=
    < AVP Header: x >
    { Media-Component-Number }
    * [ Flow-Number ]
```

6.4.11 Flow-Status AVP

The Flow-Status AVP (AVP code 511) is of type Enumerated, and describes whether the IP flow(s) are enabled or disabled. The Flow-Status AVP may be present in the Media-Description-Component AVP and/or in the Media-Sub-Component AVP. The following values are defined:

ENABLED-UPLINK (0)

This value shall be used to commit the corresponding resource reservation in the uplink direction.

ENABLED-DOWNLINK (1)

This value shall be used to commit the corresponding resource reservation in the downlink direction.

ENABLED (2)

This value shall be used to commit a resource reservation in both directions.

DISABLED (3)

This value shall be used to indicate that the corresponding resource reservation is reserved only and not (yet) committed.

REMOVED (4)

This value shall be used to release all resources associated with the corresponding resource reservation.

6.4.12 Flow-Usage AVP

The Flow-Usage AVP (AVP code 512) is of type Enumerated, and it provides information about the usage of IP Flows. The following values are defined:

NO_INFORMATION (0)

This value is used to indicate that no information about the usage of the IP flow is being provided

RTCP (1)

This value is used to indicate that an IP flow is used to transport RTCP.

NO_INFORMATION is the default value.

NOTE: An SPDF may choose not to identify RTCP flows, e.g. in order to avoid that RTCP flows are always enabled by the A-RACF.

6.4.13 Specific-Action AVP

The Specific-Action AVP (AVP code 513) is of type Enumerated. Within an initial AA-Request the SPDF may use the Specific-Action AVP to request from the A-RACF notification of specific actions. If the Specific-Action AVP is omitted within the initial AA-Request, no notification of any of the events defined below is requested.

The following event from TS 129 209 [7] is supported:

INDICATION_OF_RELEASE_OF_BEARER (4)

Within a RAR, this value shall be used when the A-RACF reports to the SPDF the release of a bearer (e.g. RCEF policies being removed). In the AAR, this value indicates that the SPDF requests the A-RACF to provide a notification at the removal of a bearer.

In addition, the present document defines two new events:

INDICATION_OF_SUBSCRIBER_DETACHMENT (6)

Within a RAR, this value shall be used when the A-RACF reports to the SPDF that a subscriber has been detached. In the AAR, this value indicates that the SPDF requests the A-RACF to provide a notification at the detachment of a subscriber.

INDICATION_OF_RESERVATION_EXPIRATION (7)

Within a RAR, this value shall be used when the A-RACF reports to the SPDF that a reservation is about to expire. In the AAR, this value indicates that the SPDF requests the A-RACF to provide a notification when a reservation expires.

Other events but the above-listed ones defined by TS 129 209 [7] are not relevant at the Rq interface and are not supported. If specified by the SPDF, these values are ignored by the A-RACF.

6.4.14 Max-Requested-Bandwidth-DL AVP

The Max-Requested-Bandwidth-DL AVP (AVP code 515) is type Unsigned32, and it indicates the maximum requested bandwidth in bits per second for a downlink IP flow. The bandwidth contains all the overhead coming from the IP-layer and the layers above, e.g. IP, UDP, RTP and RTP payload.

6.4.15 Max-Requested-Bandwidth-UL AVP

The Max -Bandwidth-UL AVP (AVP code 516) is of type Unsigned32, and it indicates the maximum requested bandwidth in bits per second for an uplink IP flow. The bandwidth contains all the overhead coming from the IP-layer and the layers above, e.g. IP, UDP, RTP and RTP payload.

6.4.16 Media-Component-Description AVP

The Media-Component-Description AVP (AVP code 517) is of type Grouped, and it contains service information for a single media component within a session. It may be based on the SDI exchanged between the AF and the AF client in the UE. The information shall be used by the A-RACF to determine the QoS requirements.

Within one Diameter message, a single IP flow shall not be described by more than one Media-Component-Description AVP.

The Media-Component-Description AVP may contain the Flow-Status AVP, which indicates the particular reservation operation to be performed on the media, as described in clauses 5.1 and 5.2.

Bandwidth information provided within the Media-Component-Description AVP applies to all those IP flows within the media component, for which no corresponding information is being provided within Media-Sub-Component AVP(s).

If a Media-Component-Description AVP is not supplied, or if optional AVP(s) within a Media-Component-Description AVP are omitted, but corresponding information has been provided in previous Diameter messages, the previous information for the corresponding IP flow(s) remains valid.

AVP format:

```
Media-Component-Description ::= < AVP Header: 517>
    { Media-Component-Number } ; Ordinal number of the media comp.
    *[ Media-Sub-Component ] ; Set of flows for one flow identifier
    [ AF-Application-Identifier ]
    [ Media-Type ]
    [ Max-Requested-Bandwidth-UL ]
    [ Max-Requested-Bandwidth-DL ]
    [ Flow-Status ]
    [ RS-Bandwidth ]
    [ RR-Bandwidth ]
    [ Reservation-Priority ]
    [ Reservation-Class ]
```

6.4.17 Media-Component-Number AVP

The Media-Component-Number AVP (AVP code 518) is of type Unsigned32, and it contains the ordinal number of the media component, assigned according to the rules in annex C of TS 129 207 [6].

6.4.18 Media-Sub-Component AVP

The Media-Sub-Component AVP (AVP code 519) is of type Grouped, and it contains the requested QoS and filters for the set of IP flows identified by their common Flow-Identifier. The Flow-Identifier is defined in TS 129 207 [6].

The Media-Sub-Component AVP may contain the Flow-Status AVP, which indicates the particular reservation operation to be performed on the flow, as described in clauses 5.1 and 5.2.

Possible Bandwidth information provided within the Media-Sub-Component AVP takes precedence over information within the encapsulating Media Component Description AVP. If a Media-Sub-Component AVP is not supplied, or if optional AVP(s) within a Media-Sub-Component AVP are omitted, but corresponding information has been provided in previous Diameter messages, the previous information for the corresponding IP flow(s) remains valid, unless new information is provided within the encapsulating Media-Component-Description AVP. If Flow-Description AVP(s) are supplied, they replace all previous Flow-Description AVP(s), even if a new Flow-Description AVP has the opposite direction as the previous Flow-Description AVP.

AVP Format:

```
Media-Sub-Component ::= < AVP Header: 519 >
    { Flow-Number }           ; Ordinal number of the IP flow
    [ Flow-Status ]
    0*2[ Flow-Description ] ; UL and/or DL
    [ Flow-Usage ]
    [ Max-Requested-Bandwidth-UL ]
    [ Max-Requested-Bandwidth-DL ]
```

6.4.19 Media-Type AVP

The Media-Type AVP (AVP code 520) is of type Enumerated, and it determines the media type of a session component. The following values are defined:

- AUDIO (0)
- VIDEO (1)
- DATA (2)
- APPLICATION (3)
- CONTROL (4)
- TEXT (5)
- MESSAGE (6)
- OTHER (0xFFFFFFFF)

6.4.20 Reservation-Class AVP

The Reservation-Class AVP (AVP code 456) is of type Unsigned32, and it contains an integer used as an index pointing to the forwarding behaviour to be applied to the particular flow, the particular tag identifying the flow and the traffic characteristics of the flow (e.g. burstiness and packet size).

6.4.21 Globally-Unique-Address AVP

The Globally-Unique-Address AVP (AVP code 300) is of type Grouped.

AVP Format:

```
Globally-Unique-Address ::= < AVP Header: 300 13019 >
                             [Frame-IP-Address]
                             [Frame-IPv6-Prefix]
                             [Address-Realm]
```

6.4.22 Address-Realm AVP

The Address-Realm AVP (AVP code 301) is of type OctetString.

6.4.23 Reservation-Priority AVP

The Reservation-Priority AVP (AVP code 458) is of type Enumerated. It may be specified in an AA-Request as a main AVP in order to associate a priority with a resource reservation or modification request. It may also be specified as part of a Media-Component AVP in order to associate a priority with resource reservations requested for the media flows identified by the Media-Sub-Component AVP(s) in a Media-Component AVP. The following values of this AVP are specified:

- **DEFAULT (0):** This is the lowest level of priority. If no Reservation-Priority AVP is specified as a main AVP in the AA-Request, this is the priority associated with a resource reservation or modification request. If no Reservation-Priority AVP is specified in a Media-Component-Description AVP, this is the priority associated with resource reservations requested for the media flows identified by the Media-Sub-Component AVP(s) in a Media-Component-Description AVP.
 - PRIORITY-ONE (1).
 - PRIORITY-TWO (2).
 - PRIORITY-THREE (2).
 - PRIORITY-FOUR (4).
 - PRIORITY-FIVE (5).
 - PRIORITY-SIX (6).
 - PRIORITY-SEVEN (7).

6.4.24 Session-Bundle-Id AVP

The Session-Bundle-Id (AVP code 400) is of type Unsigned32. It may be specified by the A-RACF in the AA-Answer, when the initial reservation is granted, in order to identify the group of sessions to which the session of the AA-Answer belongs. The value of the Session-Bundle-Id AVP is meaningful for the A-RACF only. It may be included by the A-RACF in subsequent Abort-Session-Request (ASR) messages sent to the SPDF.

6.4.25 AF-Charging-Identifier AVP

The AF-Charging-Identifier AVP (AVP code 505) is of type OctetString, contains the AF Charging Identifier that is sent by the AF. This information may be used for charging correlation between AF and RACS functional entities.

Annex A (informative): Resource reservation flow states maintained by A-RACF

Table A.1: Flow state transitions

State	Event	Action	Next State
Idle	Received Reservation Request	Verify availability of resource. Wait for the Resource Availability event.	Idle
Idle	Received Reservation&Commit Request	Verify availability of resource and perform Resource Reservation Commit. Wait for the Successful Enforcement event.	Idle
Idle	Resource Availability	Send AAA with the Result-Code AVP set to DIAMETER_SUCCESS. Initialize Authorization-Lifetime and Auth-Grace-Period timers (in case of soft-state).	Reserved
Idle	Resource not available	Send AAA with the Experimental-Result-Code AVP set to INSUFFICIENT_RESOURCES.	Idle
Idle	Successful Resource Reservation Enforcement	Send AAA with the Result-Code AVP set to DIAMETER_SUCCESS. Initialize Authorization-Lifetime and Auth-Grace-Period timers (in case of soft-state).	Committed
Idle	Unsuccessful Resource Reservation Enforcement	Send AAA with the Experimental-Result-Code AVP set to COMMIT_FAILURE.	Idle
Reserved	Received Commit Request	Enforce Resource Reservation in network elements (i.e. RCEF).	Reserved
Reserved	Successful Resource Reservation Enforcement	Send AAA with the Result-Code AVP set to DIAMETER_SUCCESS.	Committed
Reserved	Unsuccessful Resource Reservation Enforcement	Send AAA with the Experimental-Result-Code AVP to COMMIT_FAILURE.	Idle
Reserved	Received STR	Send STA, cleanup.	Idle
Reserved	Expiration of Authorization-Lifetime timer	The A-RACF shall send an unsolicited RAR message to the SPDF with the Specific-Action AVP set to INDICATION_OF_RESERVATION_EXPIRATION.	Reserved
Reserved	Expiration of Auth-Grace-Period timer	Cleanup.	Idle
Reserved	Received Resource Reservation Refresh	Send AAA with the with the Result-Code AVP set to DIAMETER_SUCCESS. Re-initialize Authorization-Lifetime and Auth-Grace-Period timers.	Reserved
Reserved	Received Modification Request	Perform Resource Reservation Modification.	Reserved
Reserved	Successful Resource Reservation Modification	Send AAA with the Result-Code AVP set to DIAMETER_SUCCESS. Re-initialize Authorization-Lifetime and Auth-Grace-Period timers (in case of soft-state).	Reserved
Reserved	Unsuccessful Resource Reservation Modification	Send AAA with the Experimental-Result-Code AVP set to MODIFICATION_FAILURE.	Reserved
Committed	Received Modification Request	Perform Resource Reservation Modification.	Committed
Committed	Successful Resource Reservation Modification	Send AAA with the Result-Code AVP set to DIAMETER_SUCCESS. Re-initialize Authorization-Lifetime and Auth-Grace-Period timers (in case of soft-state).	Committed
Committed	Unsuccessful Resource Reservation Modification	Send AAA with the Experimental-Result-Code AVP set to MODIFICATION_FAILURE.	Committed

State	Event	Action	Next State
Committed	Expiration of Authorization-Lifetime timer	A-RACF shall send an unsolicited RAR message to the SPDF with the Specific-Action AVP set to INDICATION_OF_RESERVATION_EXPIRATION.	Committed
Committed	Received Resource Reservation Refresh	Send AAA with the Result-Code AVP set to DIAMETER_SUCCESS. Re-initialize Authorization-Lifetime and Auth-Grace-Period timers (in case of soft-state)	Committed
Committed	Expiration of Auth-Grace-Period timer	Cleanup.	Idle
Committed	Received STR	Release resources, cleanup.	Idle
All	Critical Event Detected	Send ASR with appropriate Abort-Cause AVP, cleanup.	Idle
All	Non Critical Event Detected	Send RAR with appropriate Specific-Action AVP.	Unchanged

History

Document history		
V1.1.1	April 2006	Membership Approval Procedure MV 20060602: 2006-03-21 to 2006-05-19