

**Telecommunications and Internet converged Services and
Protocols for Advanced Networking (TISPAN);
Charging management**

**[Endorsement of 3GPP TS 32.240 Release 7, 3GPP TS 32.260 Release 7,
3GPP TS 32.297 Release 7, 3GPP TS 32.298 Release 7 and
3GPP TS 32.299 Release 7, modified]**



Reference

RES/TISPAN-02037-NGN-R2

Keywords

charging, endorsement, management

ETSI

650 Route des Lucioles
F-06921 Sophia Antipolis Cedex - FRANCE

Tel.: +33 4 92 94 42 00 Fax: +33 4 93 65 47 16

Siret N° 348 623 562 00017 - NAF 742 C
Association à but non lucratif enregistrée à la
Sous-Préfecture de Grasse (06) N° 7803/88

Important notice

Individual copies of the present document can be downloaded from:

<http://www.etsi.org>

The present document may be made available in more than one electronic version or in print. In any case of existing or perceived difference in contents between such versions, the reference version is the Portable Document Format (PDF). In case of dispute, the reference shall be the printing on ETSI printers of the PDF version kept on a specific network drive within ETSI Secretariat.

Users of the present document should be aware that the document may be subject to revision or change of status. Information on the current status of this and other ETSI documents is available at

<http://portal.etsi.org/tb/status/status.asp>

If you find errors in the present document, please send your comment to one of the following services:

http://portal.etsi.org/chaicor/ETSI_support.asp

Copyright Notification

No part may be reproduced except as authorized by written permission.
The copyright and the foregoing restriction extend to reproduction in all media.

© European Telecommunications Standards Institute 2008.
All rights reserved.

DECT™, PLUGTESTS™, UMTS™, TIPHON™, the TIPHON logo and the ETSI logo are Trade Marks of ETSI registered for the benefit of its Members.

3GPP™ is a Trade Mark of ETSI registered for the benefit of its Members and of the 3GPP Organizational Partners.

Contents

Intellectual Property Rights	4
Foreword.....	4
Introduction	4
1 Scope	5
2 References	5
2.1 Normative references	5
2.2 Informative references.....	6
Endorsement notice	7
Global modifications to 3GPP TS 32.240 Release 7	7
Global modifications to 3GPP TS 32.260 Release 7	9
Global modifications to 3GPP TS 32.297 Release 7	9
Global modifications to 3GPP TS 32.298 Release 7	10
Global modifications to 3GPP TS 32.299 Release 7	10
Global modifications to 3GPP TS 32.260, 3GPP TS 32.298, 3GPP TS 32.299.....	10
Annex ZA (informative): Additional information on 3GPP Charging	11
ZA.1 3GPP Standardization.....	11
ZA.2 Gap Analysis of 3GPP TS 32.240 and 3GPP TS 32.260	11
ZA.3 TISPAN Charging	11
ZA.4 IMS Offline Charging architecture (overview)	11
ZA.5 Service Charging	12
ZA.6 Inter Operator charging	12
ZA.7 IMS Online Charging architecture (overview).....	13
Annex ZB (informative): AoC in Interconnection scenarios (examples)	14
Annex ZC (informative): List of TISPAN Documents dealing with Charging and Accounting.....	19
History	21

Intellectual Property Rights

IPRs essential or potentially essential to the present document may have been declared to ETSI. The information pertaining to these essential IPRs, if any, is publicly available for **ETSI members and non-members**, and can be found in ETSI SR 000 314: "*Intellectual Property Rights (IPRs); Essential, or potentially Essential, IPRs notified to ETSI in respect of ETSI standards*", which is available from the ETSI Secretariat. Latest updates are available on the ETSI Web server (<http://webapp.etsi.org/IPR/home.asp>).

Pursuant to the ETSI IPR Policy, no investigation, including IPR searches, has been carried out by ETSI. No guarantee can be given as to the existence of other IPRs not referenced in ETSI SR 000 314 (or the updates on the ETSI Web server) which are, or may be, or may become, essential to the present document.

Foreword

This ETSI Standard (ES) has been produced by ETSI Technical Committee Telecommunications and Internet converged Services and Protocols for Advanced Networking (TISPAN), and is now submitted for the ETSI standards Membership Approval Procedure.

Introduction

The present document describes charging-related functionalities for TISPAN NGN Release 2. It is based on the endorsements of several 3GPP charging specifications. Annexes ZA and ZB contain further information.

1 Scope

The purpose of the present document is to specify charging applicable to NGN, but not to a PSTN/ISDN Emulation other than for an IMS contained within that subsystem.

The scope of the present document comprises the following functionalities:

- Offline Charging.
- Online charging.
- AoC (Advice of Charge).
- Realtime transfer of tariff information through interconnection interfaces.
- New interconnection charging capabilities.

General charging requirements for TISPAN are described in TS 181 005 [16].

2 References

References are either specific (identified by date of publication and/or edition number or version number) or non-specific.

- For a specific reference, subsequent revisions do not apply.
- Non-specific reference may be made only to a complete document or a part thereof and only in the following cases:
 - if it is accepted that it will be possible to use all future changes of the referenced document for the purposes of the referring document;
 - for informative references.

Referenced documents which are not found to be publicly available in the expected location might be found at <http://docbox.etsi.org/Reference>.

For online referenced documents, information sufficient to identify and locate the source shall be provided. Preferably, the primary source of the referenced document should be cited, in order to ensure traceability. Furthermore, the reference should, as far as possible, remain valid for the expected life of the document. The reference shall include the method of access to the referenced document and the full network address, with the same punctuation and use of upper case and lower case letters.

NOTE: While any hyperlinks included in this clause were valid at the time of publication ETSI cannot guarantee their long term validity.

2.1 Normative references

The following referenced documents are indispensable for the application of the present document. For dated references, only the edition cited applies. For non-specific references, the latest edition of the referenced document (including any amendments) applies.

- [1] ETSI TS 132 240: "Digital cellular telecommunications system (Phase 2+); Universal Mobile Telecommunications System (UMTS); Telecommunication management; Charging management; Charging architecture and principles (3GPP TS 32.240 Release 7)".
- [2] ETSI TS 132 260: "Digital cellular telecommunications system (Phase 2+); Universal Mobile Telecommunications System (UMTS); Telecommunication management; Charging management; IP Multimedia Subsystem (IMS) charging (3GPP TS 32.260)".

- [3] ETSI TS 132 296: "Digital cellular telecommunications system (Phase 2+); Universal Mobile Telecommunications System (UMTS); Telecommunication management; Charging management; Online Charging System (OCS): Applications and interfaces (3GPP TS 32.296 Release 7)".
- [4] ETSI TS 132 297: "Digital cellular telecommunications system (Phase 2+); Universal Mobile Telecommunications System (UMTS); Telecommunication management; Charging management; Charging Data Record (CDR) file format and transfer (3GPP TS 32.297 Release 7)".
- [5] ETSI TS 132 298: "Digital cellular telecommunications system (Phase 2+); Universal Mobile Telecommunications System (UMTS); Telecommunication management; Charging management; Charging Data Record (CDR) parameter description (3GPP TS 32.298 Release 7)".
- [6] ETSI TS 132 299: "Digital cellular telecommunications system (Phase 2+); Universal Mobile Telecommunications System (UMTS); Telecommunication management; Charging management; Diameter charging applications (3GPP TS 32.299)".
- [7] ETSI TS 181 005 (V1.1.1): "Telecommunications and Internet converged Services and Protocols for Advanced Networking (TISPAN); Services and Capabilities Requirements".
- [8] ETSI ES 282 001: "Telecommunications and Internet converged Services and Protocols for Advanced Networking (TISPAN); NGN Functional Architecture Release 1".
- [9] IETF RFC 3455: "Private Header (P-Header) Extensions to the Session Initiation Protocol (SIP) for the 3rd-Generation Partnership Project (3GPP)".
- [10] ETSI ES 283 003: "Telecommunications and Internet converged Services and Protocols for Advanced Networking (TISPAN); IP Multimedia Call Control Protocol based on Session Initiation Protocol (SIP) and Session Description Protocol (SDP) Stage 3 [3GPP TS 24.229, modified]".
- [11] ETSI TS 182 006: "Telecommunications and Internet converged Services and Protocols for Advanced Networking (TISPAN); IP Multimedia Subsystem (IMS); Stage 2 description (3GPP TS 23.228 v7.2.0, modified)".
- [12] ETSI TS 183 033: "Telecommunications and Internet converged Services and Protocols for Advanced Networking (TISPAN); IP Multimedia; Diameter based protocol for the interfaces between the Call Session Control Function and the User Profile Server Function/Subscription Locator Function; Signalling flows and protocol details [3GPP TS 29.228 V6.8.0 and 3GPP TS 29.229 V6.6.0, modified]".
- [13] ETSI TS 183 047: "Telecommunications and Internet converged Services and Protocols for Advanced Networking (TISPAN); NGN IMS Supplementary Services; Advice Of Charge (AOC)".
- [14] ETSI ES 201 296: "Integrated Services Digital Network (ISDN); Signalling System No.7 (SS7); ISDN User Part (ISUP); Signalling aspects of charging".
- [15] ITU-T Recommendation Q.736.3: "Reverse charging (REV)".

2.2 Informative references

- [16] ETSI TS 181 005 (V2.4.1): "Telecommunications and Internet Converged Services and Protocols for Advanced Networking (TISPAN); Service and Capability Requirements".
- [17] ETSI TS 183 058: "Telecommunications and Internet converged Services and Protocols for Advanced Networking (TISPAN); Transfer of Charging Information in SIP".
- [18] ETSI ES 282 007: "Telecommunications and Internet converged Services and Protocols for Advanced Networking (TISPAN); IP Multimedia Subsystem (IMS); Functional architecture".
- [19] ETSI TR 181 011: "Telecommunications and Internet converged Services and Protocols for Advanced Networking (TISPAN); Fixed Mobile Convergence; Requirements analysis".

- [20] ETSI TR 181 015: "Telecommunications and Internet Converged Services and Protocols for Advanced Networking (TISPAN); Requirements for Customized Originating and Terminating Multimedia Information Presentation (COMIP/CTMIP) and Customized Originating and Terminating Multimedia Information Filtering (COMIF/CTMIF) Requirements Analysis".
- [21] ETSI TS 181 016: "Telecommunications and Internet converged Services and Protocols for Advanced Networking (TISPAN); Service Layer Requirements to integrate NGN services and IPTV".
- [22] ETSI TS 181 018: "Telecommunications and Internet converged Services and Protocols for Advanced Networking (TISPAN); Requirements for QoS in a NGN".
- [23] ETSI TS 181 002: "Telecommunications and Internet converged Services and Protocols for Advanced Networking (TISPAN); Multimedia Telephony with PSTN/ISDN simulation services".
- [24] ETSI EG 201 988-4: "Telecommunications and Internet Converged Services and Protocols for Advanced Networking (TISPAN); Service Provider Access; Open Service Access for API requirements; Part 4: Version 4".
- [25] ETSI TS 182 023: "Telecommunications and Internet Converged Services and Protocols for Advanced Networking (TISPAN); Core and Enterprise NGN Interaction Scenarios and Architectural Requirements".
- [26] ETSI TS 182 024: "Telecommunications and Internet Converged Services and Protocols for Advanced Networking (TISPAN); Hosted Enterprise Services; Architecture and functional description".
- [27] ETSI TS 182 007: "Telecommunications and Internet converged Services and Protocols for Advanced Networking (TISPAN); Voice Call Continuity; Stage 2 [3GPP TS.23 206 Release 7, modified]".
- [28] ETSI TS 183 042: "Telecommunications and Internet converged Services and Protocols for Advanced Networking (TISPAN); NGN IMS Supplementary Services; Call Completion on Busy Subscriber (CCBS), Call Completion No Reply (CCNR)".
- [29] ETSI TS 183 029: "Telecommunications and Internet Converged Services and Protocols for Advanced Networking (TISPAN); PSTN/ISDN simulation services: Explicit Communication Transfer (ECT); Protocol specification".
- [30] ETSI TS 183 036: "Telecommunications and Internet converged Services and Protocols for Advanced Networking (TISPAN); ISDN- DSS1/SIP inter-working ISDN/SIP interworking".

Endorsement notice

The present document, in conjunction with 3GPP TS 32.240 Release 7, 3GPP TS 32.260 Release 7, 3GPP TS 32.297 Release 7, 3GPP TS 32.298 Release 7 and 3GPP TS 32.299 Release 7 provides the specifications for NGN charging.

Global modifications to 3GPP TS 32.240 Release 7

Throughout the text of 3GPP TS 32.240 Release 7

The references listed in the table below are replaced by references applicable to NGN.

Reference no.	Reference in 3GPP TS 32.240	Applicable reference in the present document
[50]	3GPP TS 32.299	The present document
[51]	3GPP TS 32.298	The present document
[52]	3GPP TS 32.297	The present document

All occurrences to Bearer level charging and flow-based charging (clause 5.3.1) are not included.

Advice of Charge (clause 5.5.4) is included with modifications (see separate description).

The following text needs to be added:

Realtime transfer of tariff information through interconnection interfaces

In addition to offline- and online charging, the realtime transfer of tariff information through interconnection interfaces is implemented in IMS in order to support value added services that are billed by the caller's operator, so that the caller's operator can provide AoC (Advice of Charge) to the caller for information purposes. Additionally, this tariff information may be reflected in an optional CDR parameter at the caller's operator side and/or at the service-hosting side. The transferred tariff information represents direct tariff or add-on charge, either in non-monetary units (e.g. meter-pulse) or in monetary-units (e.g. currency).

Requirements can be found in TS 181 005 V2.4.1.

Examples can be found in annex ZB.

Functional enhancements of IMS functional entities

An AS providing AoC must be capable of sending AoC-information to the UE, according to TS 183 047. AoC-information consists of tariff-related information plus further AoC-related parameters.

When an AS providing AoC needs to send AoC-information to a UE of the same domain, it retrieves tariff information, adds further AoC-related information, and maps the complete AoC-information onto SIP in order to send AoC information to the UE.

When tariff information needs to be sent downstream, the AS retrieves tariff information and maps this information into SIP, which is then transferred according to TS 183 058.

When tariff information is received through an interconnection interface according to ES 201 296, the AS providing AoC retrieves the tariff information from SIP and transfers it into AoC information.

The **MGCF** maps tariff information from SIP into ISUP (APM) and vice versa. It can also filter tariff information.

An **IBCF** can filter tariff information exchanged between two IMS or between a TISPAN IMS and a PES.

Offline Charging modifications

For interconnection scenarios where the caller's network does not have the tariff information of a service which is located in a different network, the price that the end user has to pay for that service must be available in an appropriate optional CDR-parameter at the service-hosting side (called network or called service provider). The transferred tariff information may be also stored at the originating network side.

Therefore, a new parameter which reflects the tariff (for example "Cost information") has to be added to offline charging AVPs and CDRs created by AS, IBCF, S-CSCF, MGCF as an optional parameter.

A new IBCF CDR needs to be defined, in order to collect charging and accounting information as closest as possible to the interconnection point.

Clause 3.1

3.1 Definitions

Add the following text:

add-on charge: single additional charge which does not change the current tariff. An add-on charge can either be metered in non-monetary units (e.g. meter pulse) or in monetary-units (e.g. currency).

Charge Determination Point (CDP): determines which tariff/add-on charge should be applied, and that inserts the tariff information to the appropriate SIP requests or responses. Example of a CDP is a SIP AS at the visited network providing the premium rate service..

Charge Generation Point (CGP): receives the tariff information that was added by a CDP and transferred in the appropriate SIP requests or responses. Example of a CGP is an originating SIP AS at the home network for advice of charge purposes..

Charging Trigger Function (CTF): generates charging events based on the observation of network resource usage. CTF is the focal point for collecting the information pertaining to chargeable events within the network element, assembling this information into matching charging events, and sending these charging events towards the Charging Data Function (offline charging) or Online Charging Function (online charging).

Charging Data Function (CDF): receives charging events from the Charging Trigger Function. It then uses the information contained in the charging events to construct CDRs.

Online Charging Function (OCF): receives charging events from the Charging Trigger Function. It then uses the information contained in the charging events for online charging purposes.

Tariff: set of parameters defining the network utilization charges for the use of a particular bearer / session / service. A tariff can either be metered in non-monetary units (e.g. meter pulse) or in monetary units (e.g. currency)

Global modifications to 3GPP TS 32.260 Release 7

Throughout the text of 3GPP TS 32.260 Release 7

The references listed in the table below are replaced by references applicable to NGN.

Reference no.	Reference in 3GPP TS 32.260	Applicable reference in the present document
[1]	3GPP TS 32.240	The present document
[50]	3GPP TS 32.299	The present document
[51]	3GPP TS 32.298	The present document
[52]	3GPP TS 32.297	The present document
[103]	3GPP TS 23.002	ES 282 007 [18]
[204]	3GPP TS 24.229	ES 283 003 [10]
[201]	3GPP TS 23.228	TS 182 006 [11]

Global modifications to 3GPP TS 32.297 Release 7

Throughout the text of 3GPP TS 32.297 Release 7

The references listed in the table below are replaced by references applicable to NGN.

Reference no.	Reference in 3GPP TS 32.297	Applicable reference in the present document
[1]	3GPP TS 32.240	The present document
[50]	3GPP TS 32.299	The present document
[51]	3GPP TS 32.298	The present document

The specifications described here are completely applicable.

Global modifications to 3GPP TS 32.298 Release 7

Throughout the text of 3GPP TS 32.298 Release 7

The references listed in the table below are replaced by references applicable to NGN.

Reference no.	Reference in 3GPP TS 32.298	Applicable reference in the present document
[1]	3GPP TS 32.240	The present document
[20]	3GPP TS 32.260	The present document
[40]	3GPP TS 32.299	The present document
[42]	3GPP TS 32.297	The present document
[79]	3GPP TS 24.229	ES 283 003 [10]

Bearer Level CDRs are not supported (clauses 5.1.2 and 5.2.2).

Service Level CDR parameters (clauses 5.1.4 and 5.2.4) are not supported.

Global modifications to 3GPP TS 32.299 Release 7

Throughout the text of 3GPP TS 32.299 Release 7

The references listed in the table below are replaced by references applicable to NGN.

Reference no.	Reference in 3GPP TS 32.299	Applicable reference in the present document
[1]	3GPP TS 32.240	The present document
[201]	3GPP TS 23.228	TS 182 006
[202]	3GPP TS 24.229	ES 283 003 [10]
[204]	3GPP TS 29.229	TS 183 033 [12]

AVPs belonging to the excluded CDR-parameters from 3GPP TS 32.298 are not used.

Global modifications to 3GPP TS 32.260, 3GPP TS 32.298, 3GPP TS 32.299

The 3GPP specifications TS 32.260, TS 32.298 and TS 32.299 have to be modified according to the global modifications of TS 32.240 described above.

Annex ZA (informative): Additional information on 3GPP Charging

ZA.1 3GPP Standardization

3GPP provides technical specifications globally applicable for 3G mobile system. The technical specifications are listed in clause "reference".

Since session and application layer are both bearer- and access independent, the session handling (IMS domain) works for both mobile and fixed environment.

ZA.2 Gap Analysis of 3GPP TS 32.240 and 3GPP TS 32.260

The 3GPP charging architecture and principles are appropriate to cover the charging requirements of TISPAN.

ZA.3 TISPAN Charging

Unless stated explicitly, the functional entities and interfaces identified in this clause are identical to those defined in 3GPP TS 32.240, 3GPP TS 32.260, 3GPP TS 32.296, 3GPP TS 32.297, 3GPP TS 32.298 and 3GPP TS 32.299. Except when highlighting explicitly a difference, the descriptions provided in the present document are intended to provide tutorial information only and in case of discrepancy with the definitions in 3GPP TS 32.240, 3GPP TS 32.260, 3GPP TS 32.296, 3GPP TS 32.297, 3GPP TS 32.298 and 3GPP TS 32.299 the definitions in 3GPP TS 32.240 and 3GPP TS 32.260, 3GPP TS 32.296, 3GPP TS 32.297, 3GPP TS 32.298 and 3GPP TS 32.299 shall take precedence.

ZA.4 IMS Offline Charging architecture (overview)

The offline charging functionality is based on the IMS network nodes reporting accounting information upon reception of various SIP methods or ISUP messages, as most of the accounting relevant information is contained in these messages.

Figure ZA.1 shows the nodes that are involved in the off-line charging chain and an example offline charging scenario. For the information on other supported offline charging scenarios refer to 3GPP TS 32.240 and 3GPP TS 32.260.

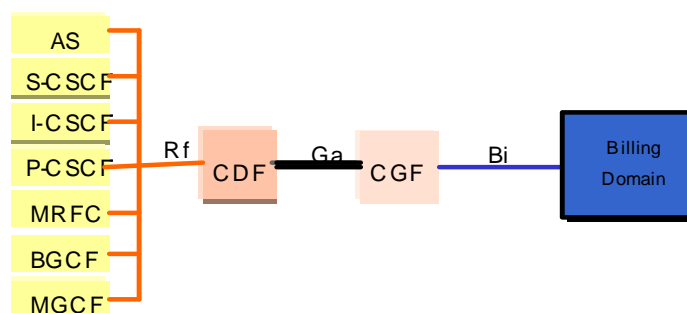

Figure ZA.1: Overall offline charging architecture

The IMS charging architecture specifies that for offline charging all communications between the network entities and the CDF are carried out on the **Rf** interface. The Rf-interface is the reference point between the CTFs of the IMS nodes and the CDF, where Diameter Accounting Messages are conveyed to the CDF (see 3GPP TS 32.260 and 3GPP TS 32.299). The CTF of an IMS node is the client of the Diameter Accounting Application, as defined in 3GPP TS 32.299.

The CDF receives the accounting messages and creates Charging Data Records (CDR) for each source within the IMS (i.e. S/P/I-CSCF, MRFC, AS etc.). CDRs are transmitted to the Billing Domain via the Bi Interface. For further information see 3GPP TS 32.298.

The correlation of charging information for an IMS session can be based on the use of IMS Charging Identifiers (ICID). The ICID is conveyed by the SIP P-charging vector header, as described in RFC 3455 [9].

ZA.5 Service Charging

Services can be charged by using the IMS charging architecture and the existing CDR layouts as described in 3GPP TS 32.240, 3GPP TS 32.260, 3GPP TS 32.298 and 3GPP TS 32.299.

Service charging can be based on the AS-CDR, as described in 3GPP TS 32.260 and 3GPP TS 32.298. This CDR contains (among others) service-specific parameters, for example the "Service Specific Data", as well as SDP-based media descriptions and the addresses of both calling party and called party.

ZA.6 Inter Operator charging

Various interconnection scenarios can occur in TISpan. These scenarios are described within ES 282 007. This means that there is a need to have inter operator charging. To support inter operator charging the inter network correlation and Inter Operator Identifier (IOI) concepts of 3GPP TS 32.240 can be used.

For inter operator charging it is important to be able to identify the operators involved into the charging. Within legacy networks, the trunk-group IDs can be used to identify the respective operators. In order to identify operators with interconnection between two IMS-networks, between IMS and PES, or between an IMS and a legacy system, the values of IOI (Inter Operator Identifier) can be used for this purpose.

The existing CDRs of S-CSCF and P-CSCF may be used as a base for inter operator charging. If the border control concepts are implemented, CDRs of IBCF may be used. In case the Trunk-Group-IDs are needed, their values can be retrieved from the MGCF CDR.

ZA.7 IMS Online Charging architecture (overview)

Figure ZA.2 shows an overview of the Online Charging functionality, as designed by 3GPP. For information on 3GPP online charging architecture see 3GPP TS 32.296.

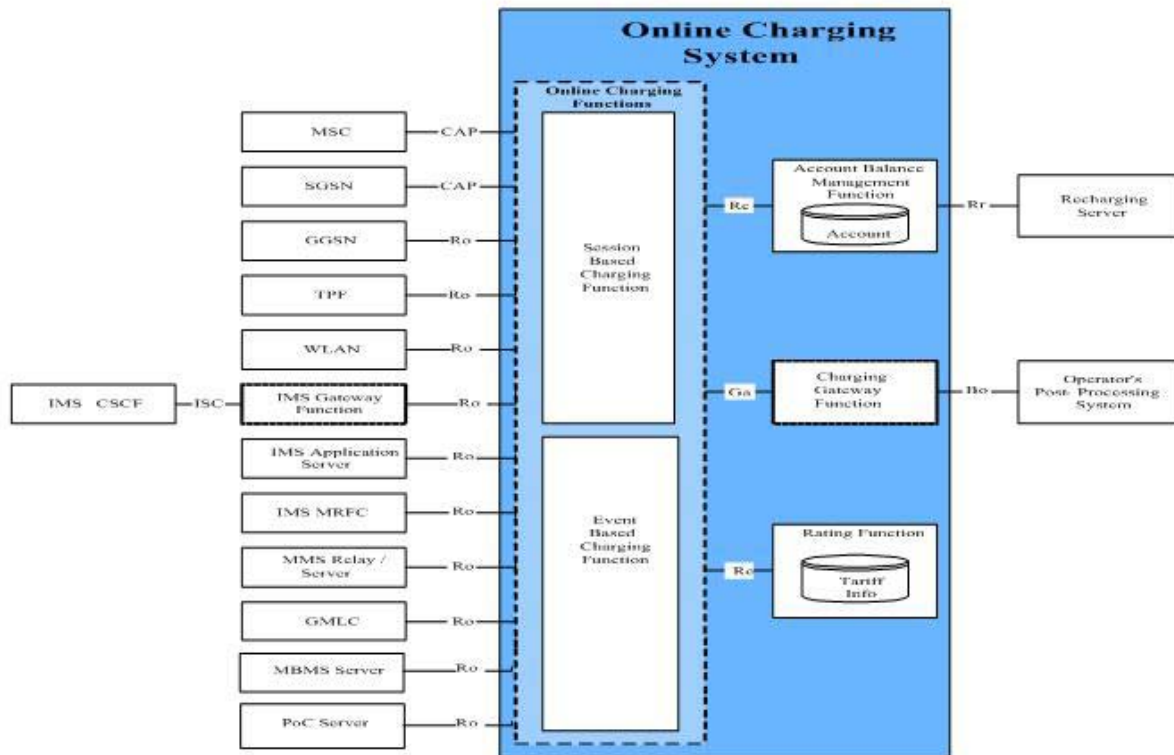

Figure ZA.2

Annex ZB (informative): AoC in Interconnection scenarios (examples)

Example #1: IMS-User calls special/premium service from PSTN/IN

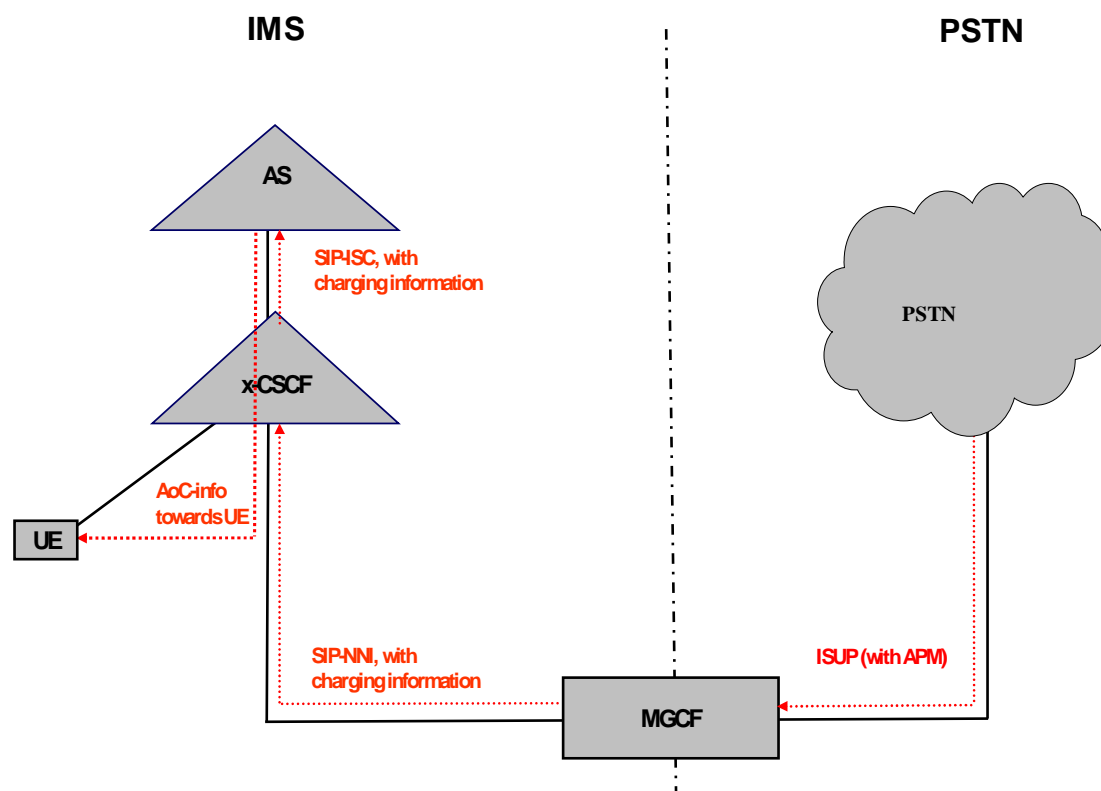

Figure ZB.1

Tariff information (that is CDP, Charging Determination Point) resides in the PSTN, and is unknown in the caller's network (=IMS). It must be conveyed from PSTN to IMS.

ISUP contains signalling support of charging, namely APM information according to ES 201 296. This tariff-related information must be mapped into the SIP protocol. Other standards than APM can also be supported.

The IMS AS providing the AoC-information (CGP, Charging Generation Point) to the UE filters the tariff information from the SIP-protocol, optionally adds further AoC-information, and puts the whole AoC-information onto the UNI interface to provide AoC to the user, according to TS 183 047.

The AoC-information transferred to the UE can also be stored within the IMS to be used e.g. in case of dispute.

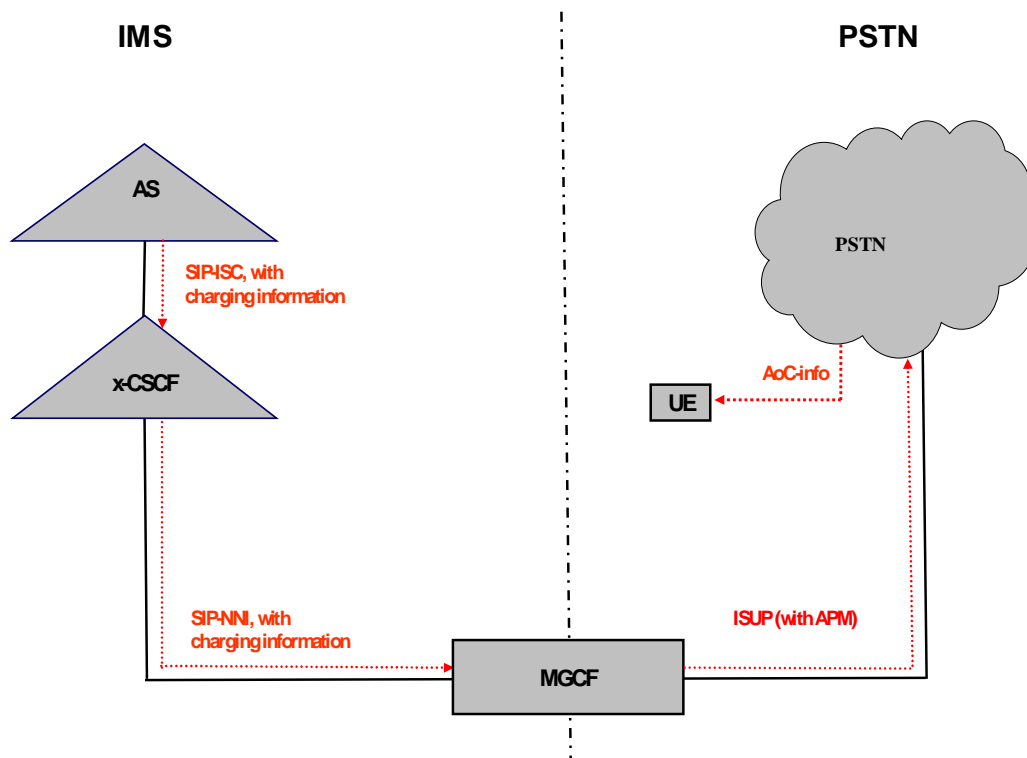
Example #2: PSTN-User calls special service from IMS**Figure ZB.2**

Tariff information (that is CDP) resides in IMS and is unknown in the caller's network (=PSTN).

It must be mapped into the SIP-protocol, and conveyed from IMS to PSTN, where it is mapped into the APM-information.

The PSTN can then provide AoC-information to the caller. This means that CGP resides in PSTN. This concerns PSTN only and is out of scope for TISPAN.

The IMS AS or other functional entities of IMS may additionally add the price information into the offline charging CDR as an optional parameter.

Example #3: Interworking between two TISpan-IMSs

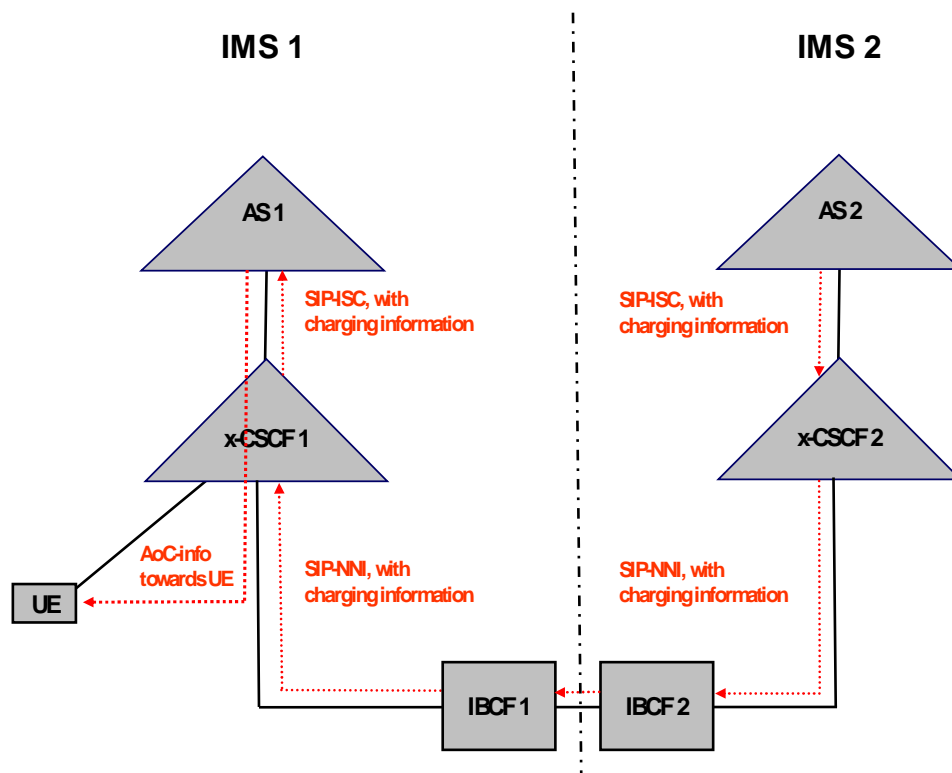

Figure ZB.3

Tariff information (that is CDP) resides in IMS 2 and is unknown in the caller's network (=IMS 1).

It must be mapped into the SIP-protocol, and conveyed from IMS 2 to IMS 1 via SIP.

The IMS AS providing the AoC-information (CGP) within IMS 1 filters the tariff information from the SIP-protocol, optionally adds further AoC-information, and puts the whole AoC-information onto the UNI interface to provide AoC to the user, according to TS 183 047.

The AoC-information transferred to the UE can also be stored within the IMS 1 to be used e.g. in case of dispute.

The IMS AS or other functional entities of IMS at the IMS 2 may additionally add the price information into the offline charging CDR as an optional parameter.

Example #4: IMS-User calls special/premium service from PES (PSTN/ISDN Emulation Subsystem)

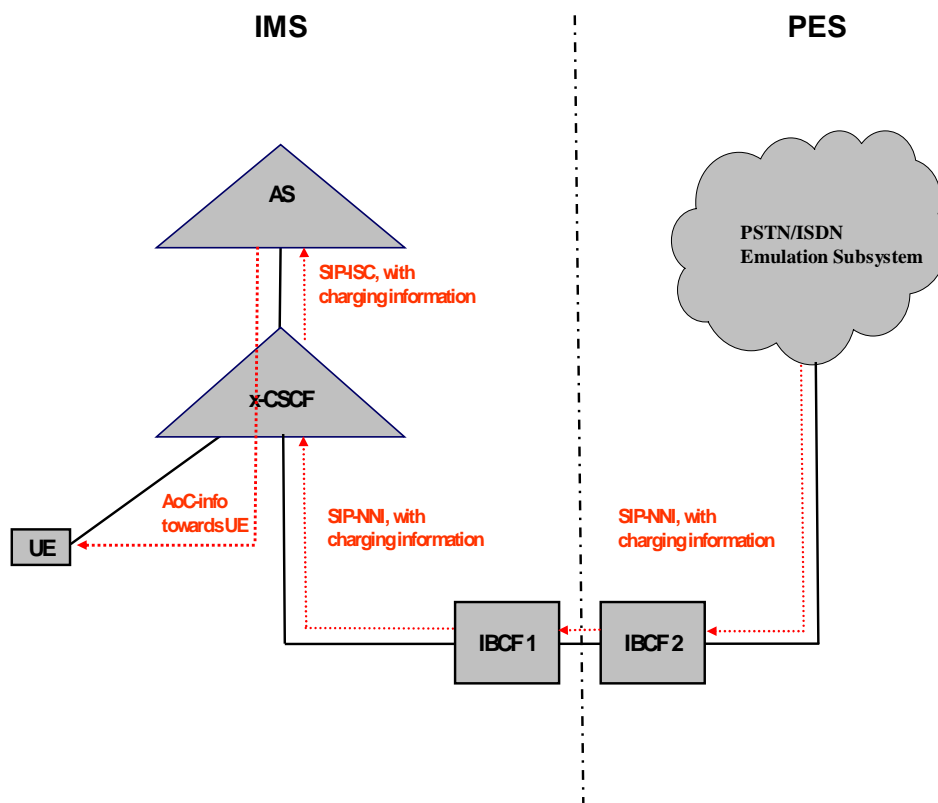

Figure ZB.4

Tariff information (that is CDP) resides in PES and is unknown in the caller's network (=IMS).

It must be conveyed from PES to IMS via SIP.

The AS within the NGN filters the tariff information from the SIP-protocol, potentially adds further AoC-information, and puts the whole AoC-information onto the UNI interface to provide AoC to the user, according to TS 183 047.

The AoC-information transferred to the UE can also be stored within the IMS to be used e.g. in case of dispute.

Example #5: PES-User calls special/premium service from IMS

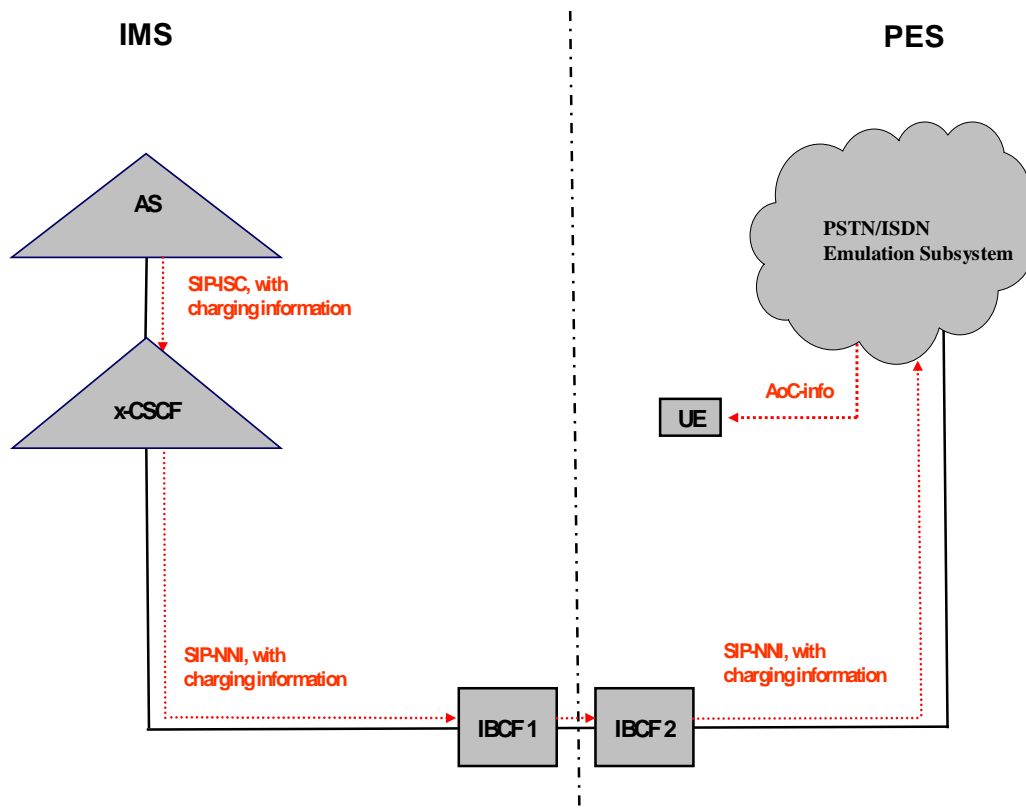

Figure ZB.5

Tariff information (that is CDP) resides in IMS (in called network) and is unknown in the caller's network (=PES).

It must be mapped into SIP-protocol, and conveyed from IMS to PES.

The PES can then provide AoC-information to the caller. This means that CGP resides in PES. (This is a PES functionality and out of scope of this specification.)

The IMS AS or other functional entities of IMS may additionally add the price information into the offline charging CDR as an optional parameter.

Annex ZC (informative): List of TISPAN Documents dealing with Charging and Accounting

Here following, a list of the main TISPAN documents dealing with charging and accounting is provided. For each document, the TISPAN number and title, together with a brief description about the charging topic, are provided.

Document Number	Document Title	Description
TR 181 011	Fixed Mobile Convergence; Requirements Analysis	Two general requirements of charging for FMC
TS 181 005	Service and Capability Requirements	General requirements about the collection of charging information in the form of CDR. Indication of TS 122 115 as the reference document for charging requirements.
TR 181 015	Requirements for Customized Originating and Terminating Multimedia Information Presentation (COMIP/CTMIP) and Customized Originating and Termination Multimedia Information Filtering (COMIF/CTMIF); Requirements Analysis	No impact of the COMIP CTMIP COMIF CTMIF for Reverse Charging
TS 181 016	Service Layer Requirements to Integrate NGN Services and IPTV	General requirement about charging controlled by NGN operators for IPTV services
TS 181 018	Requirements for QoS in a NGN	Accounting functionalities able to use the QoS reporting information to enrich the CDR for billing system
TS 181 019	Business Communication and Business Trunking Requirements (BCBT)	Charging and Accounting requirements for Next Generation Corporate Network (NGCN). Also reference to the charging requirements of 181 005.
TS 181 002	Multimedia Telephony with PSTN/ISDN simulation services	Advice of Charge and Reverse Charging requested
EG 201 988-4	Service Provider Access; Open Service Access for API requirements; Part 4: Version 4	Support split of charging
TS 182 006	IP Multimedia Subsystem (IMS); Stage 2 description [3GPP TS 23.228 V7.2.0, modified]	It provides the necessary adaptations to the 3GPP IMS, in order to support the Access Networks and terminals.
TS 182 019	Resource and Admission Control Sub-system (RACS); Functional Architecture; Release 2	RACS collects charging information; support to offline charging is provided; R _i interface to charging functions
TS 182 023	Core and Enterprise NGN Interaction Scenarios	Use of Inter Operator Identifier (IOI) between NGCN and NGN
TS 182 024	Hosted Enterprise Services; Architecture and Functional Description	Functional requirements for HES charging and data collection
TS 182 026	IMS-based PSTN/ISDN Emulation Sub-system (PES); Functional Architecture	Interfaces to the Charging Functions
ES 282 001	NGN Functional Architecture Release 2	Charging and Data Collection Functions are described
TS 182 007	Voice Call Continuity (VCC); Stage 2 [3GPP TS 23.206 Release 7, modified]	Charging is generated on both CS and IMS operator networks for the subscriber
TS 183 042	PSTN/ISDN Simulation Services; Completion of Communications to Busy Subscriber (CCBS) Completion of Communications by No Reply (CCNR); Protocol specification	Advice of Charge

Document Number	Document Title	Description
TS 183 047	NGN Signalling Control Protocol; Advice of Charge (AoC) PSTN/ISDN Simulation Services	The document specifies the stage three Protocol Description of the Advice of Charge (AoC) service, based on stage 1 and 2 of the ISDN Supplementary Service Advice of Charge for all calls (permanent mode). Three AOC services exist: Charging information: (1) at communication set-up time (AOC-S), (2) during the communication (AOC-D), (3) at the end of the communication (AOC-E).
ES 283 003	IP Multimedia Call Control Protocol based on Session Initiation Protocol (SIP) and Session Description Protocol (SDP) Stage 3 [3GPP TS 24.229 (Release 7), modified]	The document endorses the 3GPP TS 24.229 about Session Initiation Protocol (SIP) and Session Description Protocol (SDP); Stage 3 (Release 7): present the list of changes in line with the requirement of TISPAN NGN.
TS 183 029	PSTN/ISDN simulation services: Explicit Communication Transfer (ECT); Protocol specification	Support of classical charging models
TS 183 036	ISDN/SIP interworking: Protocol specification, Release 2	Reverse Charging is listed in the supplementary services (reference to ITU-T Recommendation Q.736.3)
TS 183 058	SIP Transfer of Charging Information	It specifies the Stage 3 of the real-time transfer of charging information between a Charge Determination Point (CDP) and a Charge Generation Point (CGP) by means of the Session Initiation Protocol (SIP).

History

Document history		
V1.1.1	June 2006	Publication
V2.0.6	January 2008	Membership Approval Procedure MV 20080321: 2008-01-22 to 2008-03-21