

# ETSI ES 203 136 V1.1.1 (2013-05)



## **Environmental Engineering (EE); Measurement methods for energy efficiency of router and switch equipment**

---

Reference

DES/EE-00024

---

Keywords

configuration, EEER, router, switch

**ETSI**

650 Route des Lucioles  
F-06921 Sophia Antipolis Cedex - FRANCE

Tel.: +33 4 92 94 42 00 Fax: +33 4 93 65 47 16

Siret N° 348 623 562 00017 - NAF 742 C  
Association à but non lucratif enregistrée à la  
Sous-Préfecture de Grasse (06) N° 7803/88

---

**Important notice**

Individual copies of the present document can be downloaded from:

<http://www.etsi.org>

The present document may be made available in more than one electronic version or in print. In any case of existing or perceived difference in contents between such versions, the reference version is the Portable Document Format (PDF). In case of dispute, the reference shall be the printing on ETSI printers of the PDF version kept on a specific network drive within ETSI Secretariat.

Users of the present document should be aware that the document may be subject to revision or change of status. Information on the current status of this and other ETSI documents is available at

<http://portal.etsi.org/tb/status/status.asp>

If you find errors in the present document, please send your comment to one of the following services:

[http://portal.etsi.org/chaicor/ETSI\\_support.asp](http://portal.etsi.org/chaicor/ETSI_support.asp)

---

**Copyright Notification**

No part may be reproduced except as authorized by written permission.  
The copyright and the foregoing restriction extend to reproduction in all media.

© European Telecommunications Standards Institute 2013.  
All rights reserved.

DECT™, PLUGTESTS™, UMTS™ and the ETSI logo are Trade Marks of ETSI registered for the benefit of its Members.  
3GPP™ and LTE™ are Trade Marks of ETSI registered for the benefit of its Members and  
of the 3GPP Organizational Partners.  
GSM® and the GSM logo are Trade Marks registered and owned by the GSM Association.

---

# Contents

|  |    |
|--|----|
| Intellectual Property Rights .....   | 4  |
| Foreword.....  | 4  |
| Introduction .....   | 4  |
| 1 Scope .....  | 5  |
| 2 References .....   | 5  |
| 2.1 Normative references .....   | 5  |
| 2.2 Informative references.....  | 5  |
| 3 Definitions and abbreviations.....   | 5  |
| 3.1 Definitions .....  | 5  |
| 3.2 Abbreviations .....  | 6  |
| 4 Equipment Classification .....   | 6  |
| 4.1 Router .....   | 6  |
| 4.2 Switch.....  | 7  |
| 5 Definitions of the Equipment Energy Efficiency Ratio for Router and Switch ..... | 7  |
| 6 Measurement Methods .....  | 10 |
| 6.1 Measurement conditions.....  | 10 |
| 6.2 Equipment Configuration .....  | 10 |
| 6.3 Measurement Procedures .....   | 11 |
| 6.4 Alternative Measurement Method .....   | 12 |
| History .....  | 14 |

---

## Intellectual Property Rights

IPRs essential or potentially essential to the present document may have been declared to ETSI. The information pertaining to these essential IPRs, if any, is publicly available for **ETSI members and non-members**, and can be found in ETSI SR 000 314: "*Intellectual Property Rights (IPRs); Essential, or potentially Essential, IPRs notified to ETSI in respect of ETSI standards*", which is available from the ETSI Secretariat. Latest updates are available on the ETSI Web server (<http://ipr.etsi.org>).

Pursuant to the ETSI IPR Policy, no investigation, including IPR searches, has been carried out by ETSI. No guarantee can be given as to the existence of other IPRs not referenced in ETSI SR 000 314 (or the updates on the ETSI Web server) which are, or may be, or may become, essential to the present document.

---

## Foreword

This ETSI Standard (ES) has been produced by ETSI Technical Committee Environmental Engineering (EE).

---

## Introduction

The present document defines the energy consumption metrics and measurement methods for router and Ethernet switch equipment.

---

# 1 Scope

The present document defines the methodology and the test conditions to measure the power consumption of router and switch equipment.

The present document is applicable to Core, edge and access routers.

Home gateways are not included in the present document.

---

# 2 References

References are either specific (identified by date of publication and/or edition number or version number) or non-specific. For specific references, only the cited version applies. For non-specific references, the latest version of the reference document (including any amendments) applies.

Referenced documents which are not found to be publicly available in the expected location might be found at <http://docbox.etsi.org/Reference>.

NOTE: While any hyperlinks included in this clause were valid at the time of publication, ETSI cannot guarantee their long term validity.

## 2.1 Normative references

The following referenced documents are necessary for the application of the present document.

- [1] ATIS-0600015.03.2009: "Energy Efficiency for Telecommunication Equipment: Methodology for Measurement and Reporting for Router and Ethernet Switch Requirements".
- [2] ATIS-0600015.2009: "Energy Efficiency for Telecommunication Equipment: Methodology for Measurement and Reporting General Requirements".

## 2.2 Informative references

The following referenced documents are not necessary for the application of the present document but they assist the user with regard to a particular subject area.

- [i.1] ETSI EN 300 132-2: "Environmental Engineering (EE); Power supply interface at the input to telecommunications and datacom (ICT) equipment; Part 2: Operated by -48 V direct current (dc)".

---

# 3 Definitions and abbreviations

## 3.1 Definitions

For the purposes of the present document, the following terms and definitions apply:

**aggregation mode:** mode in which, a few (typically higher bandwidth) ports on the equipment are considered UPLINK ports; while majority (typically lower bandwidth) ports are considered user ports

NOTE: In this configuration the data flow is strictly from user ports to uplink ports and vice versa. User ports do not communicate with each other through this equipment.

**core mode:** mode in which all ports are considered similar and have similar bandwidth

NOTE: In this configuration the data flow is so that each port communicate with one another.

**maximum configuration:** configuration with maximum capacity whole slots of the equipment are configured with maximum interface bandwidth line cards, all of the interfaces can work at the maximum data rate

## 3.2 Abbreviations

For the purposes of the present document, the following abbreviations apply:

|      |                                       |
|------|---------------------------------------|
| AC   | Alternating Current                   |
| ATM  | Asynchronous Transfer Mode            |
| DC   | Direct Current                        |
| EE   | Energy Efficiency                     |
| EEER | Equipment Energy Efficiency Ratio     |
| EER  | Energy Efficiency Rating              |
| EUT  | Equipment Under Test                  |
| FDDI | Fibre Distributed Data Interface      |
| FE   | Fast Ethernet                         |
| GE   | Giga Ethernet                         |
| IMIX | Internet MIX traffic                  |
| IP   | Internet Protocol                     |
| MPU  | Main Processing Unit                  |
| NDR  | Non Drop Rate                         |
| OSI  | Open System Interconnection Reference |
| PAR  | Peak to Average Ratio                 |
| PoE  | Power over Ethernet                   |
| QoS  | Quality of Service                    |

---

## 4 Equipment Classification

### 4.1 Router

Routers are typical packet switching equipment running at the network layer of OSI layer 3. The router selects the optimal route according to the destination address of the received packet through a network and forwards the packet to the next router. The last router is responsible for sending the packet to the destination host.

Routers connect different physical networks and manually configure and run standard protocols to obtain the information of each subnet such as label, number of devices, names and addresses, etc. and thus generate and maintain a live forwarding routing table. Based on this table, each IP packet passing these routers will be assigned an optimal path according to the longest matching rules and be forwarded to the right path, if the path searching of the packet fails, this packet will be abandoned.

The router can connect two or more independent and flexible logical networks using different data packets method and media access method. Routers have not any requirements for hardware in each subnet but shall run the software using the same network layer protocol.

In light of the router different application scenarios, it can be classified into core routers, service routers, broadband access routers, and aggregation routers (Core, Edge, access routers in ATIS 0600015.03.2009 [1] classification).

Routers have the following typical features:

- 1) Provide multiple protocols on network layer to connect different types of networks.
- 2) Provide multiple types of interfaces so as to realize the conversion between the packets with different encapsulations and transmission across different networks.
- 3) Support packet fragmentation and reassembly.
- 4) Provide large-scale packet buffers so as to support QoS and traffic engineering.
- 5) Provide large-scale routing tables and support large-scale Layer 3 services within intra-networks or inter-networks.

## 4.2 Switch

Switches generally refer to equipments that exchange information in a communications system. They include Ethernet switches, ATM switches, FDDI switches, and token ring switches. Ethernet switch is widely used because of fast development of Ethernet technologies and its low costs, therefore, switches in the present document refer to Ethernet switches.

Switches are typical packet switching devices at the data link layer of OSI layer 2. Based on the destination data link layer addresses in the Layer 2 switching tables, each received packet, will be assigned an optimal path according to the accurate matching rule and be forwarded to the right path, if the path searching of the packet fails, this packet will be sent to the broadcast domain to which it belongs. The Layer 2 switching table is generated by switch network self-learning.

The main function of switches is packet switching at the data link layer, but with the development of network technologies, the relationship between network hierarchy and hardware equipment has become ambiguous, it is not limited to Layer 2 services, the routing function is also integrated into most switches to support Layer 3 services, if the path searching of packets entering the switch fails in Layer 2, then it will be delivered to the routing module for path searching and forwarding in Layer 3. For example, some high-level switches also have the routing function, the little differences between switch and router lie in routing items and performance specifications.

Switches have the following typical features:

- 1) Support data link layer protocols, such as 802.3, Ethernet II, etc.
- 2) Provide Ethernet optical and electrical interfaces with different data rates.
- 3) Packet buffers are not large and low requirements for QoS and traffic engineering are allowed.
- 4) Demand a large-scale Layer 2 switching table and low requirements for the Layer 3 routing table.

---

## 5 Definitions of the Equipment Energy Efficiency Ratio for Router and Switch

Based on the routers and switches energy consumption measurements and research, it is showed that the main influencing factors of their energy consumption are the quantity of service boards configured, traffic configuration, traffic load and ambient conditions.

These factors shall be taken into account when defining the energy efficiency indicators.

Therefore, Energy Efficiency Ratio of Equipment (EEER) is defined as the throughput forwarded by 1 watt, unit: Gbps/Watt. The Higher the EEER correspond to better energy efficiency.

Depending on equipment type application or usage [1]. Aggregation mode (uplink/downlink ports) see figure 1 or figure 2. Core mode (all ports to all ports) see figure 2 the EEER is defined in the following way.

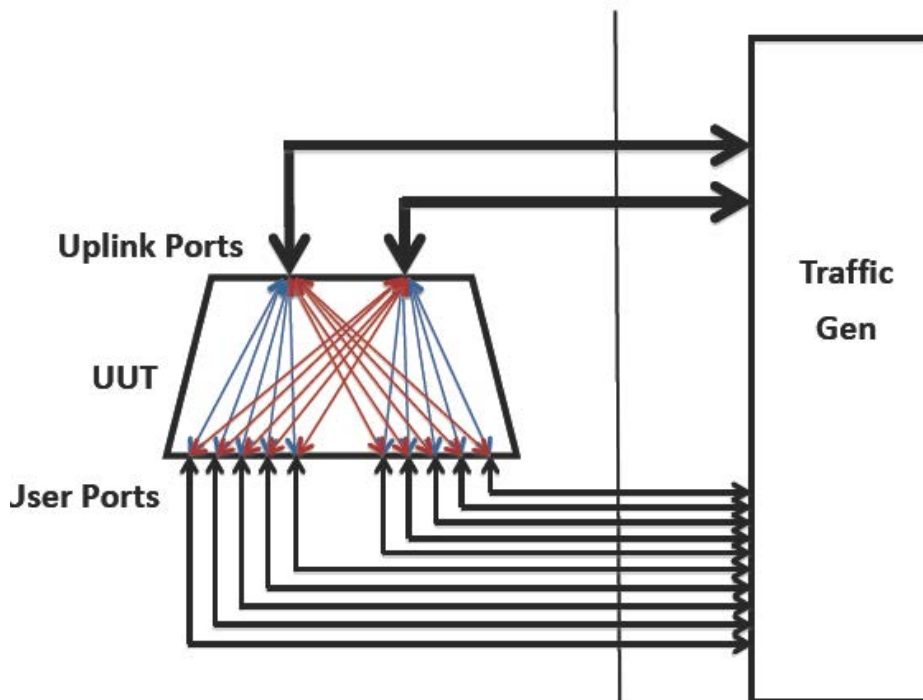

Figure 1: Aggregation mode functionality

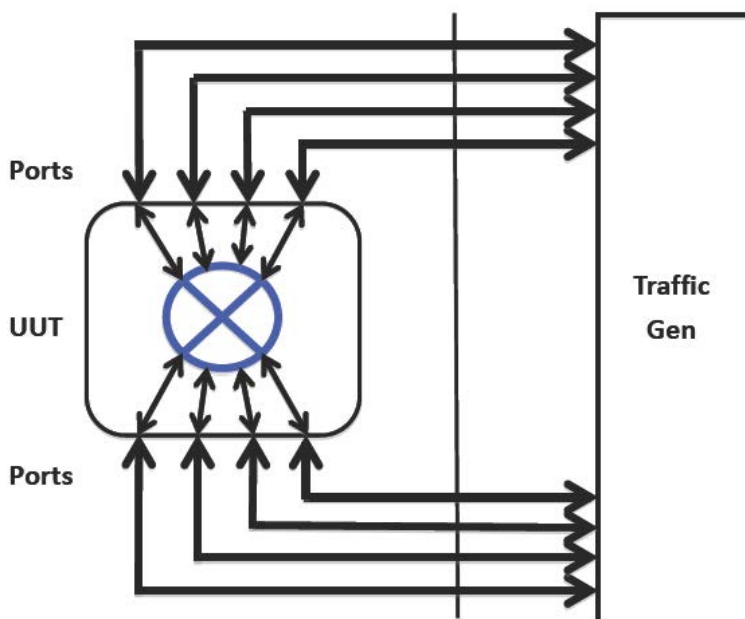

Figure 2: Core mode functionality

EEER definition for:

$$EEER = T_i / P_i$$

Where:

$$T_i = \sum_{j=1}^m B_j T_j$$



**Table 1: Traffic load level and weight multipliers**

| Equipment type | Traffic load level percentage of maximum load |        |     | Weight factor |     |     |
|----------------|---|--------|-----|---------------|-----|-----|
|                | high  | medium | Low | B1            | B2  | B3  |
| Core equipment | 100 %   | 30 %   | 0 % | 0,1           | 0,8 | 0,1 |
| Edge/access    | 100 %   | 10 %   | 0 % | 0,1           | 0,8 | 0,1 |

- $B_j$ : Weight multipliers for different traffic level, see table 1; the summation of  $B_1$  to  $B_3$  equal to 1.
- $T_i$ : Total capacity of the interfaces for a fixed configuration model (the sum of interface bandwidth).
- $T_i$  for a core functionality mode: total weighted throughput is the sum of all interface throughputs measured in full mesh traffic topology.
- $T_i$  for an aggregation mode: the weighted sum of uplink port throughputs, measured in uplink/downlink mesh configuration.
- $P_i$ : Weighted power for different traffic loads (independent of usage model or equipment type).

The weighted power  $P_i$  is calculated as:

$$P_i = \sum_{j=1}^m B_j P_j$$

Where:

For core equipment:

- $m$ : The number of Traffic load levels, here 100 %, 30 %, and 0 % traffic loads are defined, so  $m = 3$ .
- $B_j$ : The weight multipliers of Traffic load levels for a fixed configuration model see table 1  $P_j$ : Power of the equipment in each traffic load level see table 1 (100 %, 30 %, and 0 %),  $P_1$  is for 100 % load,  $P_2$  is for 30 % load,  $P_3$  is for 0 % load.

For edge/access equipment:

- $m$ : The number of Traffic load levels is 3 and they are 100 %, 10 % and 0 % traffic loads and sleep mode respectively, so  $m = 3$ .
- $B_j$ : The weight multipliers of Traffic load levels for a fixed configuration model, here  $B_1$  is 0,1 for 100 % load,  $B_2$  is 0,8 for 10 % load,  $B_3$  is 0,1 for 0 % load, the summation of  $B_1$  to  $B_3$  equal to 1.
- $P_j$ : Power consumption of the equipment in each traffic load level (100 %, 10 %, and 0 %),  $P_1$  is for 100 % load,  $P_2$  is for 10 % load,  $P_3$  is for 0 % load,  $P_4$  is for sleep mode.

NOTE: 0 % traffic load means that no packets are transmitted but all ports are linked and ready to pass traffic.

---

## 6 Measurement Methods

### 6.1 Measurement conditions

The measurement condition reported in ATIS-0600015.2009 [2] shall be applied except for the follows points here reported:

#### 1) Environmental conditions

The power measurements shall be performed in a laboratory environment under the following conditions:

- Room Temperature: 23 °C to 27 °C.
- Room Relative Humidity: 25 % to 75 %.
- Atmospheric pressure: 86 kPa to 106 kPa.

#### 2) Test voltage

The equipment shall be powered by and the input voltage of the DC power source shall be relatively constant.

- DC Powered Equipment: with a nominal voltage of -48 V DC according to EN 300 132-2 [i.1], shall be tested with a test voltage of -54,5 V  $\pm$ 1,5 V. Equipment using voltage other than -48 V DC shall be tested at  $\pm$ 1 % of the nominal voltage.
- AC Powered Equipment: Equipment with a nominal voltage of 230 V shall be tested with a test voltage of 230 V  $\pm$ 5 % and at 50 Hz  $\pm$ 1 % of frequency.

#### 3) Requirements for the measurement instruments

All measurement instruments used shall be calibrated by counterpart national metrology institute and within calibration due date, and the measurement tolerance shall be within  $\pm$ 1 %.

- Power Source: Power sources used to provide power to the equipment under test shall be capable of providing a minimum of 1,5 times the power rating of the equipment under test.
- Power Measurement Instrument: Power measurement instrument (such as voltmeter and amperometer or power analyzer) shall have a resolution of 0,5 % or better. AC power measurement instrument shall have the following minimum characteristics:
  - 1) A minimum digitizing sample rate of 40 kHz.
  - 2) Input circuitry with a minimum bandwidth of 80 kHz.
  - 3) It shall be capable of accurate readings of waveforms having peak to average ratio (PAR) factors up to at least 5.

### 6.2 Equipment Configuration

For measurements the equipment under test (switch or router) could be configured either in "**aggregation**" mode or "**core**" mode.

These modes reflect the real life use of equipment, which determines the traffic flow through the equipment.

The Equipment configurations reported in ATIS-0600015.3.2009 [1] shall be applied except for the following points here reported.

- Equipment shall be tested with all redundancies in place and corresponding functions shall be activated, the redundancy modules including but not limited to power supply unit redundancy, Main Processing Unit (MPU), redundancy, etc.

- For the equipment supporting PoE power supply, the PoE power supply modules shall be disabled. No PoE power is supplied.
- For optical ports, 10 Km optical modules need to be used for FE, GE and 10 GE ports; for the electrical and optical multiplexing ports, the electrical ports need to be tested.
- Traffic type is defined in table 2.

**Table 2: Simple IMIX model**

| Package Size (Bytes) | Proportion of Total | Bandwidth |
|----------------------|---------------------|-----------|
| 64                   | 7 parts             | 10,3      |
| 594                  | 4 parts             | 54,7      |
| 1 518                | 1 parts             | 35        |

The 100 % data rate is the maximum NDR (Non Drop Rate) supported by the equipment:

- The capacity of the equipment shall be obtained from traffic generator, unit is Gbps, the sum of bandwidth of all the ports calculated cannot be used in EEER calculation.
- It is not allowed to change the software and hardware configurations of the equipment under test respect to the normal commercial software and configuration.

## 6.3 Measurement Procedures

### Step 1: Identify the Equipment Type

To identify the router or switch equipment type, which is classified as access/edge or core type.

### Step 2: Verification of Equipment under Test

Select the corresponding configuration model defined in the present document, make sure the equipment under test meet the requirements of each model such as the capacity, amounts of the interface and basic functions and so on, and produce the network configuration diagram and a list of functional and service boards and other critical components (for example optical modules, fans, etc.).

### Step 3: Verification of Measurement parameters

Make sure the measurement conditions meet the requirements in clause 6.1.

### Step 4: Qualification of Maximum Traffic load and Capacity Measurement

With the equipment configured as stated above, the equipment shall be operated for at least 15 minutes for initialization until equipment run stable, after that, configure the equipment according to clause 6.2 and make the data rate of all ports reach to the rate with no packet loss, measure the capacity of all in egress direction and record them, this capacity is the maximum capacity( $T_{max}$ ) for each port. If some ports reach to line rate but lose packet, adjust the capacity of those ports until no packet loss, record the capacity of each egress port, calculate the total capacity( $T_i$ ) of all ports.

For the aggregation mode equipment, only the bandwidth of uplink ports are calculated in the capacity ( $T_i$ ).

For other traffic capacity the total throughput can be estimate and used in the formula:

$$T_i = \sum_{j=1}^m B_j T_j$$

### Step 5: Power Consumption Measurement for 100 % traffic loads (for all equipment)

With all equipment ports operating stably under maximum traffic load ( $T_{max}$ ) for 5 minutes, record the average input power over 5 minutes, this value is  $P_1$ .

**Step 6: Power Consumption Measurement for 30 % traffic loads (only core equipment)**

With all equipment ports operating stably under 30 % of maximum traffic load ( $30 \% * T_{\max}$ ) for 5 minutes, record the average input power over 5 minutes, this value is  $P_2$  for core equipment.

**Step 7: Power Consumption Measurement for 10 % traffic loads (only access/edge equipment)**

With the equipment operating stably under 10 % of maximum traffic load ( $10 \% * T_{\max}$ ) for 5 minutes, record the average input power over 5 minutes, this value is  $P_2$  for access/edge equipment.

NOTE 1: Burst traffic model is used for 10 % traffic load, and the cycle of Burst is 20 milliseconds. To obtain the 10 % traffic load, the packets shall be sent in 100 % traffic at the first 2 milliseconds of cycle and then no packets (0 % traffic) are sent in remaining 18 milliseconds and this process is repeated periodically in 20 milliseconds cycles.

**Step 8: Power Consumption Measurement for 0% traffic loads (for all equipment)**

With all equipment ports operating stably under 0 % traffic load for 5 minutes, record the average input power over 5 minutes, this value is  $P_3$ .

**Step 9: Calculate the Weighted Power Consumption**

Use the formula:

$$P_i = \sum_{j=1}^m B_j P_j$$

And relevant weight  $B_j$  depending on equipment type.

**Step 10: EEER Calculation for each Configuration Model**

Calculate the EEER based on the  $P_i$  and the  $T_i$  of the configuration model according to the formulas in clause 5.

NOTE 2: If the EUT supports energy saving features, those features shall be used during testing procedure.

## 6.4 Alternative Measurement Method

This type of equipment could be configured to provide similar functionality with different board types and different compositions in the same rack/box. To reduce the test timing an alternative method is proposed that can provide an estimation of the EER in conservative mode.

In case of contestation the EER determined by a real measure on a defined configuration takes precedence over the EER calculated with the method described in this clause.

This alternative measurement method reduces the number of traffic generators and service boards required and can extrapolate the power consumption of any configuration.

In this case, the "base" system configuration is defined as a common system part, used by all modules. It may include chassis, fan tray, routing engine, etc.

NOTE: In the ATIS standard [1] a similar methodology is called Modular Method.

Common system is equipment with no service board installed and including main processing boards, fan tray, power input boards, etc., which is used by all service boards.

- **Step 1:** Configure the system with the all service boards to obtain a full chassis and set the system at the traffic load defined in clause 6.2 within the boards, and test the power used  $P_T$ .
- **Step 2:** Remove one service board and test the power used of this configuration  $P_1$ .
- **Step 3:** Calculate the power used by the service board:  $P_{\text{Board } 1} = (P_T - P_1)$ .

- **Step 4:** Repeat steps 1 and 2 with other traffic load.
- **Step 5:** According to above steps, test the power used by other service boards,  $P_{\text{Board } 2}$ ,  $P_{\text{Board } 3}$ ,  $P_{\text{Board } n}$ .
- **Step 6:** Calculate the power used by the common system; this power is determined by subtracting the power used by different service boards present in the system from the power measured in the initial configuration during step 1 at maximum traffic  $P_1$ .

$$P_{\text{comm}} = P_T - \sum_1^n k_i P_{\text{board}_i}$$

Where  $k_i$  is the number of service board<sub>*i*</sub> present in the initial configuration and  $P_{\text{board}_i}$  is the power used by service board<sub>*i*</sub> identified during step 3.

- **Step 7:** The weighted power of the board is calculated using the following formula:

$$P_{\text{wboard}} = \sum_1^n B_j P_j$$

$P_{\text{wboard}}$  is the weighted power of board 1...n

$P_j$  is the power of the estimated configuration with traffic *j*

$B_j$  is the weighted factor depending on traffic load and equipment type see clause 5.

The estimated EEER is:

$$EEER = \frac{\sum_{i=1}^n T_i}{P_{\text{comm}} + \sum_{i=1}^n P_{\text{wboard}_i}}$$

Where:

$T_i$  is the weighted Throughput of any service board calculated as in clause 6.3.

$P_{\text{wboard}_i}$  is the total weighted power of the board.

---

## History

| <b>Document history</b> |            |   |
|-------------------------|------------|---|
| V1.0.0                  | March 2013 | Membership Approval Procedure MV 20130528: 2013-03-29 to 2013-05-28 |
| V1.1.1                  | May 2013   | Publication   |
|                         |            |   |
|                         |            |   |
|                         |            |   |