



**Environmental Engineering (EE);
Measurement method for power consumption and
energy efficiency of wireless access network equipment**

Reference

RES/EE-EEPS00022ed141

Keywords

energy efficiency, GSM, LTE, WCDMA

ETSI

650 Route des Lucioles
F-06921 Sophia Antipolis Cedex - FRANCE

Tel.: +33 4 92 94 42 00 Fax: +33 4 93 65 47 16

Siret N° 348 623 562 00017 - NAF 742 C
Association à but non lucratif enregistrée à la
Sous-Préfecture de Grasse (06) N° 7803/88

Important notice

The present document can be downloaded from:

<http://www.etsi.org>

The present document may be made available in electronic versions and/or in print. The content of any electronic and/or print versions of the present document shall not be modified without the prior written authorization of ETSI. In case of any existing or perceived difference in contents between such versions and/or in print, the only prevailing document is the print of the Portable Document Format (PDF) version kept on a specific network drive within ETSI Secretariat.

Users of the present document should be aware that the document may be subject to revision or change of status. Information on the current status of this and other ETSI documents is available at

<http://portal.etsi.org/tb/status/status.asp>

If you find errors in the present document, please send your comment to one of the following services:

http://portal.etsi.org/chaicor/ETSI_support.asp

Copyright Notification

No part may be reproduced or utilized in any form or by any means, electronic or mechanical, including photocopying and microfilm except as authorized by written permission of ETSI.

The content of the PDF version shall not be modified without the written authorization of ETSI.

The copyright and the foregoing restriction extend to reproduction in all media.

© European Telecommunications Standards Institute 2014.

All rights reserved.

DECT™, **PLUGTESTS™**, **UMTS™** and the ETSI logo are Trade Marks of ETSI registered for the benefit of its Members. **3GPP™** and **LTE™** are Trade Marks of ETSI registered for the benefit of its Members and of the 3GPP Organizational Partners.

GSM® and the GSM logo are Trade Marks registered and owned by the GSM Association.

Contents

Intellectual Property Rights	5
Foreword.....	5
Modal verbs terminology.....	5
Introduction	5
1 Scope	6
2 References	6
2.1 Normative references	6
2.2 Informative references.....	7
3 Definitions and abbreviations.....	8
3.1 Definitions.....	8
3.2 Abbreviations	9
4 Assessment method	10
4.1 Assessment levels.....	10
4.2 Assessment procedure	10
5 Reference configurations and Measurement conditions.....	11
5.1 Reference configurations.....	11
5.2 Measurement and test equipment requirements	12
5.2.1 BS Configuration	13
5.2.2 RF output (transmit) power/signal	13
5.2.3 Environmental conditions	13
5.2.4 Power supply	14
6 Static power consumption measurement.....	14
6.1 Calculation of average static power consumption for integrated BS.....	14
6.2 Calculation of average static power consumption for distributed BS.....	14
6.3 Measurement method for static BS power consumption	15
6.3.1 Test setup for power consumption measurement.....	15
6.3.2 Power consumption measurement procedure	16
7 Dynamic BS energy efficiency measurement	16
7.1 Test setup for dynamic energy efficiency measurement	16
7.2 Capacity test procedure	17
7.2.1 UE distribution for dynamic test method	17
7.2.2 UE performance requirements	18
7.2.3 Throughput setup	19
7.2.4 Verification of minimum data delivered to UEs	21
7.2.5 Definition of power consumption for integrated BS in dynamic method	22
7.2.6 Definition of power consumption for distributed BS in dynamic method	22
7.2.7 Energy efficiency for WCDMA and LTE.....	22
7.2.8 Energy efficiency for GSM.....	24
7.3 Coverage efficiency test procedure	24
7.4 Uncertainty	25
8 Measurement report.....	25
Annex A (normative): Test Reports	26
A.1 General information to be reported	26
A.2 Static power consumption report.....	27
Annex B: Void	30
Annex C (normative): Coverage area definition	31

Annex D (normative):	Reference parameters for GSM/EDGE system.....	33
Annex E (normative):	Reference parameters for WCDMA/HSDPA system	35
Annex F (normative):	Reference parameters for LTE system	36
Annex G:	Void	40
Annex H (normative):	Definition of load levels for dynamic test.....	41
Annex I (informative):	Reference parameters for multi-standard (MCPA) system.....	44
Annex J (normative):	Uncertainty assessment	45
J.1	General requirements	45
J.2	Components contributing to uncertainty	46
J.2.1	Contribution of the measurement system	46
J.2.1.1	Measurement equipment (static & dynamic)	46
J.2.1.2	Attenuators, cables (static and dynamic)	47
J.2.1.3	User equipment (UE) or UE emulator (dynamic)	47
J.2.2	Contribution of physical parameters.....	47
J.2.2.1	Impact of environmental parameters (static and dynamic)	47
J.2.2.2	Impact of path loss(dynamic).....	47
J.2.2.3	Data volume (dynamic)	47
J.2.3	Variance of device under test	47
J.3	Uncertainty assessment	48
J.3.1	Combined and expanded uncertainties	48
J.3.2	Cross correlation of uncertainty factors.....	49
J.3.3	Maximum expanded uncertainty	49
Annex K (informative):	Reference parameters for WiMAXTM system	50
Annex L (informative):	Derivation of formula for verification of minimum data delivered to UEsduring dynamic test	52
Annex M (informative):	BS site efficiency parameters	55
Annex N (informative):	Example assessment.....	57
Annex O (informative):	Bibliography.....	59
History		60

Intellectual Property Rights

IPRs essential or potentially essential to the present document may have been declared to ETSI. The information pertaining to these essential IPRs, if any, is publicly available for **ETSI members and non-members**, and can be found in ETSI SR 000 314: "*Intellectual Property Rights (IPRs); Essential, or potentially Essential, IPRs notified to ETSI in respect of ETSI standards*", which is available from the ETSI Secretariat. Latest updates are available on the ETSI Web server (<http://ipr.etsi.org>).

Pursuant to the ETSI IPR Policy, no investigation, including IPR searches, has been carried out by ETSI. No guarantee can be given as to the existence of other IPRs not referenced in ETSI SR 000 314 (or the updates on the ETSI Web server) which are, or may be, or may become, essential to the present document.

Foreword

This final draft ETSI Standard (ES) has been produced by ETSI Technical Committee Environmental Engineering (EE), and is now submitted for the ETSI standards Membership Approval Procedure.

Modal verbs terminology

In the present document "**shall**", "**shall not**", "**should**", "**should not**", "**may**", "**may not**", "**need**", "**need not**", "**will**", "**will not**", "**can**" and "**cannot**" are to be interpreted as described in clause 3.2 of the [ETSI Drafting Rules](#) (Verbal forms for the expression of provisions).

"**must**" and "**must not**" are **NOT** allowed in ETSI deliverables except when used in direct citation.

Introduction

Energy efficiency is one of the critical factors of the modern telecommunication systems. The energy consumption of the access network is the dominating part of the wireless telecom network energy consumption. Therefore the core network and the service network are not considered in the present document. In the radio access network, the power consumption of the Base Station is dominating (depending on technology often also referred to as BTS, NodeB, eNodeB, etc. and in the present document denoted as BS). The power consumption of Radio Network Control nodes (RNC or BSC) are covered in ETSI ES 201 554 [5].

Since the scope of the present document is to define methods for evaluation of power consumption and energy efficiency of base station in static and dynamic mode respectively the following definitions are defined:

- Average power consumption of BS equipment under static test conditions: the BS average power consumption is based on measured BS power consumption data under static condition when the BS is loaded artificially in a lab for three different loads, low, medium and busy hour under given reference configuration.
- BS efficiency under dynamic load conditions: the BS capacity under dynamic traffic load provided within a defined coverage area and the corresponding power consumption is measured for given reference configurations.

1 Scope

The present document defines methods to analyse the power consumption and the energy efficiency of base stations in static and dynamic mode respectively.

The present document version covers the following radio access technologies:

- GSM.
- WCDMA.
- LTE.
- WiMAX™ (informative only).

The methodology described in the present document is to measure base station static power consumption and dynamic energy efficiency. Within the present document they are referred to as static and dynamic measurements.

The results based on "static" measurements of the BS power consumption provide a power consumption figure for BS under static load. The results based on "dynamic" measurements of the BS provide energy efficiency information for BS with dynamic load.

Energy consumption of terminal (end-user) equipment is outside the scope of the present document.

The scope of the present document is not to define target values for the power consumption nor the energy efficiency of equipment.

The results should only be used to assess and compare the power consumption and the energy efficiency of base stations.

The present document does not cover multi RAT and MCPA. Only Wide Area Base Stations are covered in this version. Other type of BS will be considered in future versions of the present document.

2 References

References are either specific (identified by date of publication and/or edition number or version number) or non-specific. For specific references, only the cited version applies. For non-specific references, the latest version of the reference document (including any amendments) applies.

Referenced documents which are not found to be publicly available in the expected location might be found at <http://docbox.etsi.org/Reference>.

NOTE: While any hyperlinks included in this clause were valid at the time of publication, ETSI cannot guarantee their long term validity.

2.1 Normative references

The following referenced documents are necessary for the application of the present document.

- [1] Void.
- [2] ETSI TS 125 104: "Universal Mobile Telecommunications System (UMTS); Base Station (BS) radio transmission and reception (FDD) (3GPP TS 25.104)".
- [3] CENELEC EN 50160: "Voltage characteristics of electricity supplied by public electricity networks".
- [4] ETSI EN 300 132-2: "Environmental Engineering (EE); Power supply interface at the input to telecommunications and datacom (ICT) equipment; Part 2: Operated by -48 V direct current (dc)".

- [5] ETSI ES 201 554: "Environmental Engineering (EE); Measurement method for Energy efficiency of Mobile Core network and Radio Access Control equipment".
- [6] Void.
- [7] ETSI TS 125 141 (V8.3.0): "Universal Mobile Telecommunications System (UMTS); Base Station (BS) conformance testing (FDD) (3GPP TS 25.141 version 8.3.0 Release 8)".
- [8] ETSI TS 125 101: "Universal Mobile Telecommunications System (UMTS); User Equipment (UE) radio transmission and reception (FDD) (3GPP TS 25.101)".
- [9] ETSI TS 136 101: "LTE; Evolved Universal Terrestrial Radio Access (E-UTRA); User Equipment (UE) radio transmission and reception (3GPP TS 36.101)".
- [10] ETSI TS 136 211: "LTE; Evolved Universal Terrestrial Radio Access (E-UTRA); Physical channels and modulation (3GPP TS 36.211)".
- [11] ETSI TS 136 141 (V8.6.0): "LTE; Evolved Universal Terrestrial Radio Access (E-UTRA); Base Station (BS) conformance testing (3GPP TS 36.141 version 8.6.0 Release 8)".
- [12] ETSI TS 136 104: "LTE; Evolved Universal Terrestrial Radio Access (E-UTRA); Base Station (BS) radio transmission and reception (3GPP TS 36.104)".
- [13] IEEE 802.16e: "IEEE Standard for Local and metropolitan area networks Part 16: Air Interface for Fixed and Mobile Broadband Wireless Access Systems Amendment for Physical and Medium Access Control Layers for Combined Fixed and Mobile Operation in Licensed Bands".

NOTE: WiMAX™ Technologies and Standards.

2.2 Informative references

The following referenced documents are not necessary for the application of the present document but they assist the user with regard to a particular subject area.

- [i.1] Void.
 - [i.2] IEC/ISO Guide 98-3: "Evaluation of measurement data - Guide to the expression of uncertainty in measurement" 2008 or equivalent GUM:2008/JCGM 100:2008.
- NOTE: Available at http://www.bipm.org/utils/common/documents/jcgm/JCGM_100_2008_E.pdf.
- [i.3] ETSI TS 145 005: "Digital cellular telecommunications system (Phase 2+); Radio transmission and reception (3GPP TS 45.005)".
 - [i.4] ISO/IEC 17025: "General requirements for the competence of testing and calibration laboratories".
 - [i.5] ETSI TS 151 021: "Digital cellular telecommunications system (Phase 2+); Base Station System (BSS) equipment specification; Radio aspects (3GPP TS 51.021)".
 - [i.6] IEC 62018: "Power consumption of information technology equipment - Measurement methods".
- NOTE: Equivalent to CENELEC EN 62018.
- [i.7] ETSI TS 102 706 (V1.2.1): "Environmental Engineering (EE); Measurement Method for Energy Efficiency of Wireless Access Network Equipment".

3 Definitions and abbreviations

3.1 Definitions

For the purposes of the present document, the following terms and definitions apply:

activity level: traffic model in dynamic measurement is divided into three activity levels corresponding to low-, medium- and busy hour traffic

activity time: time to generate data from the server to at least one UE (in the scenario for dynamic measurement this corresponds to the transmission time for the UE group with highest path loss)

Base Station (BS): radio access network component which serves one or more radio cells and interfaces the user terminal (through air interface) and a wireless network infrastructure

BS test control unit: unit which can be used to control and manage BS locally in a lab

busy hour: period during which occurs the maximum total load in a given 24-hour period

busy hour load: in static measurement it is the highest measurement level of radio resource configuration and in dynamic measurement is the highest activity level

distributed BS: BS architecture which contains remote radio heads (i.e. RRH) close to antenna element and a central element connecting BS to network infrastructure

dynamic measurement: power consumption measurement performed with different activity levels and path losses

efficiency: throughout the present document the term efficiency is used as the relation between the useful output (telecom service, etc.) and energy consumption

integrated BS: BS architecture in which all BS elements are located close to each other; for example in one single cabinet

NOTE: The integrated BS architecture may include Tower Mount Amplifier (TMA) close to antenna.

IPERF: Software that allows the user to set various parameters that can be used for testing a network, or alternately for optimizing or tuning a network

NOTE: IPERF has a client and server functionality, and can measure the throughput between the two ends, either unidirectionally or bi-directionally. It is open source software and runs on various platforms including Linux, Unix and Windows.

low load: in static measurement it is the lowest measurement level of radio resource configuration and in dynamic measurement is the lowest activity level

medium load: in static measurement it is the medium measurement level of radio resource configuration and in dynamic measurement is the medium activity level

power saving feature: software/hardware feature in a BS which contributes to decrease power consumption

site correction factor: scaling factor to scale the BS equipment power consumption for reference site configuration taking into account different power supply solutions, different cooling solutions and power supply losses

static measurement: power consumption measurement performed with different radio resource configurations with pre-defined and fixed load levels

UE group: group of UEs whose pathlosses to the BS are identical

Wide Area Base stations: Base Stations that are characterized by requirements derived from Macro Cell scenarios with a BS to UE minimum coupling loss equals to 70 dB and having a rated output power (PRAT) above 38 dBm, where the Rated output power, PRAT, of the BS is the mean power level per carrier for BS operating in single carrier, multi-carrier, or carrier aggregation configurations that the manufacturer has declared to be available at the antenna connector during the transmitter ON period according to 3GPP standardization, ETSI TS 136 104 [12] and ETSI TS 125 104 [2]

3.2 Abbreviations

For the purposes of the present document, the following abbreviations apply:

AC	Alternating Current
AMR	Adaptive Multi Rate
BCCH	Broadcast Control CHannel
BER	Bit Error Rate
BH	Busy Hour
BS	Base Station
BSC	Base Station Controller
BTS	Base Transceiver Station
BW	Bandwidth
CCE	Control Channel Elements
CCH	Common CHannel
CCPCH	Common Control Physical Channel
CF	Cooling Factor
CPICH	Common Pilot CHannel
CS	Circuit Switched
DC	Direct Current
DL	DownLink
DPCH	Dedicated Physical CHannel
DUT	Device Under Test
EC	Energy for Central part
EDGE	Enhanced Data rate GSM Evolution
EPRE	Emitted Power per Resource Element
ERRH	Energy for Remote Radio Part
FCH	Frequency Correction Channel
GERAN	GSM/EDGE Radio Access Network
GSM	Global System for Mobile communication
GUM	Guide to the expression of Uncertainty in Measurement
HSPA	High Speed Packet Access
HW	HardWare
JCGM	Joint Committee for Guides in Metrology
KPI	Key Performance Indicator
LTE	Long Term Evolution
MAP	Media Access Protocol
MCPA	Multi Carrier Power Amplifier
MIMO	Multiple Input Multiple Output
NA	Not Applicable
NIST	National Institute of Standards and Technology
OFDM	Orthogonal Frequency Division Multiplex
PA	Power Amplifier
PBCH	Packet Broadcast Control Channel
PBH	Power during Busy Hour
PC	Power for Central Part
PCFICH	Physical Control Format Indicator CHannel
PCH	Paging Channel
PCM	Pulse Code Modulation
PDCCH	Physical Downlink Control CHannel
PDF	Proportional Distribution Function
PDSCH	Physical Downlink Shared CHannel
PFF	Power Feeding Factor
PHICH	Physical Hybrid ARQ Indicator CHannel
PICH	Paging Indicator Channel
PRB	Physical Resource Block
PRRH	Power for Remote Radio Head
PSF	Power Supply Factor
PSS	Primary Synchronizing Signal
RAT	Radio Access Technology
RBS	Radio Base Station

REG	Resource Element Group
RF	Radio Frequency
RNC	Radio Network Controller
RRH	Remote Radio Head
RS	Reference Signals
RX	Receiver
SAE	System Architecture Evolution
SCH	Synchronization Channel
SDH	Synchronous Digital Hierarchy
SIMO	Single Input Multiple Output
SSS	Secondary Synchronizing Signal
SW	SoftWare
TD	Time during one Duty cycle
TF	Tolerance Factor
TMA	Tower Mount Amplifier
TP	ThroughPut
TRX	Transceiver
TS	Time Slot
TX	Transmitter
UDP	User Data Protocol
UE	User Equipment
UL	UpLink
UL/DL	Uplink/Downlink
WCDMA	Wideband Code Division Multiple Access
WiMAX™	Worldwide interoperability for Microwave Access

4 Assessment method

This clause is valid for both static and dynamic measurement methods.

4.1 Assessment levels

The present document defines a two level assessment methods to be used to both evaluate power consumption and energy efficiency of base stations. The two levels are:

- BS equipment average power consumption for which the present document defines reference BS equipment configurations and reference load levels to be used when measuring BS power consumption.
- BS equipment energy efficiency defined as the measured capacity for a defined coverage area is divided by the simultaneously measured energy consumption.

4.2 Assessment procedure

The assessment procedure contains the following tasks:

- 1) Identification of equipment under test:
 - 1.1 Identify BS basic parameters (table A.1 in annex A).
 - 1.2 List BS configuration and traffic load(s) for measurements (annexes D, E, F, H, K).
 - 1.3 List of used power saving features and capacity enhancement features.
- 2) Static power measurement, Measure BS equipment power consumption for required load levels (see clause 6).
- 3) Efficiency measurement under dynamic load conditions, Measure BS equipment capacity and power consumption under required conditions (see clause 7).
- 4) Collect and report the measurement results.

5 Reference configurations and Measurement conditions

This clause is valid for both static and dynamic measurement methods.

The BS equipment is a network component which serves one or more cells and interfaces the mobile station (through air interface) and a wireless network infrastructure (BSC or RNC) ([i.3] and [2]).

5.1 Reference configurations

Reference configurations are defined for the different technologies (GSM/EDGE, WCDMA/HSPA, LTE, WiMAX™) in the corresponding annexes (annexes D to G).

These configurations include compact and distributed BS, mast head amplifiers, remote radio heads, RF feeder cables, number of carriers, number of sectors, power range per sector, frequency range, diversity, MIMO.

The BS shall be tested with its intended commercially available configuration at temperatures defined in clause 5.2.3 "Environmental conditions". It shall be clearly reported in the measurement report if the BS can not be operated without additional air-conditioning at the defined temperatures.

Appropriate transmission e.g. a transport function for E1/T1/Gbit Ethernet or other providing capacity corresponding to the BS capacity, shall be included in the BS configuration during testing. The configurations include:

- 1) UL diversity (This is a standard feature in all BS. Therefore it is considered sufficient that the test is performed on the main RX antenna only. The diversity RX shall be active during the measurement without connection to the test signal).
- 2) DL diversity (Not considered in R99 and HSPA. LTE: Transmission mode 3 "Open loop spatial multiplexing" shall be according to ETSI TS 136 211 [10] (2x2 DL MIMO)).

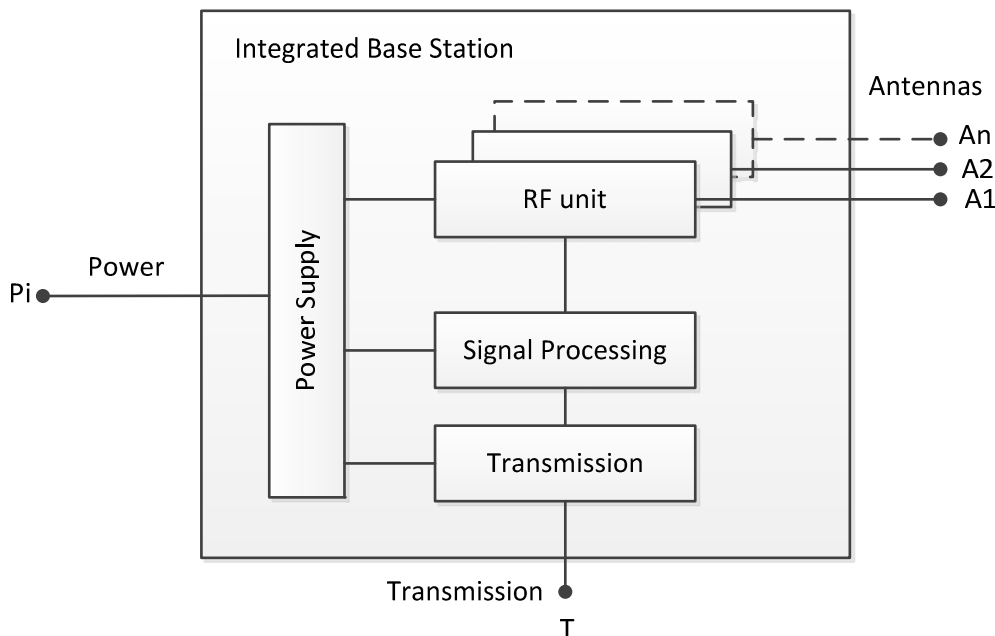

Figure 1: Integrated BS model

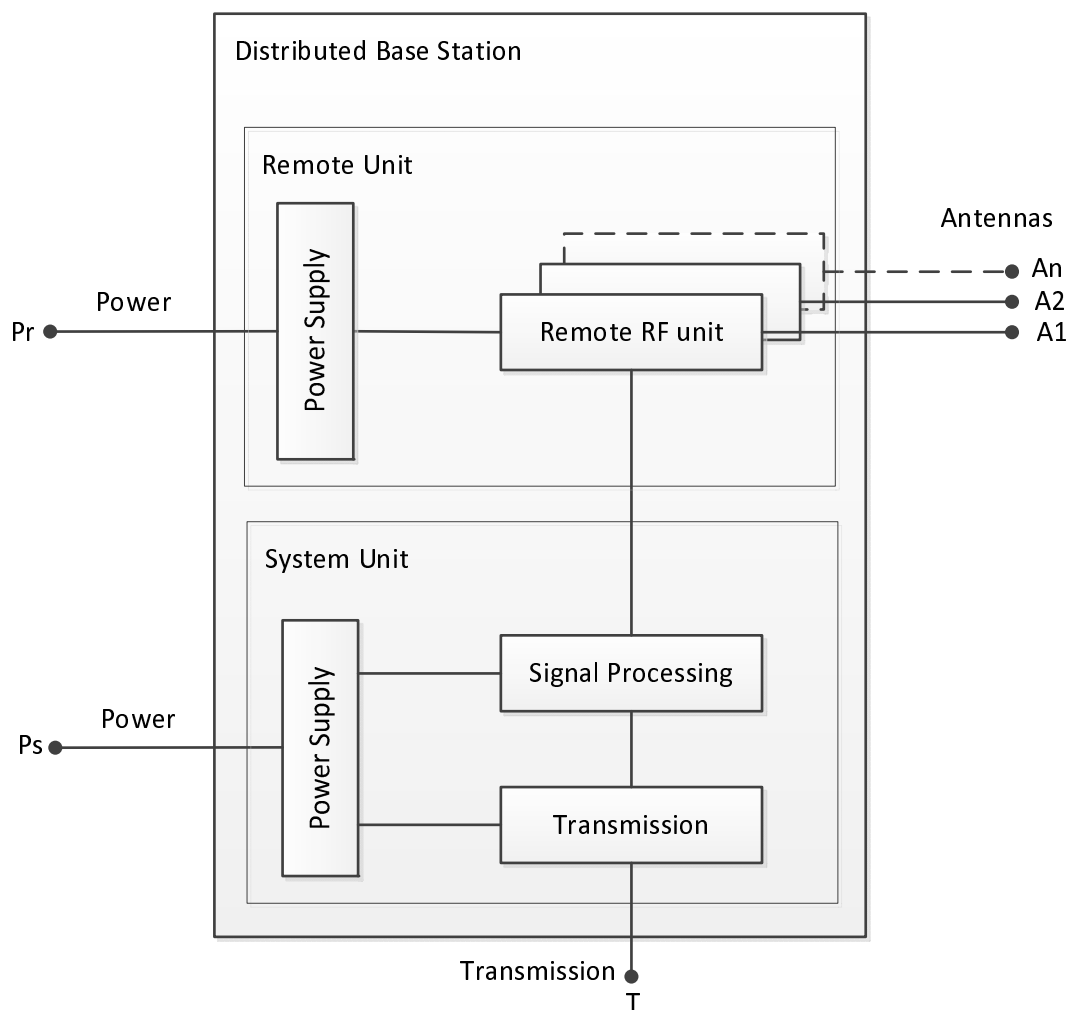

Figure 2: Distributed BS model

5.2 Measurement and test equipment requirements

The measurement of the power consumption shall be performed by either measuring the power supply voltage and true effective current in parallel and calculate the resulting power consumption (applicable only for DC) or with a wattmeter (applicable for both AC and DC). The measurements can be performed by a variety of measurement equipment, including power clamps, or power supplies with in-built power measurement capability.

All measurement equipment shall be calibrated and shall have data output interface in order to allow long term data recording and calculation of the complete power consumption over a dedicated time.

The measurement equipment shall comply with following attributes:

- Inputpower:
 - Resolution: $\leq 10 \text{ mA}$; $\leq 100 \text{ mV}$; $\leq 100 \text{ mW}$.
 - DC current: $\pm 1 \%$.
 - DC voltage: $\pm 1 \%$.
 - AC power: $\pm 1 \%$.
 - An available current crest factor of 5 or more.
 - The test instrument shall have a bandwidth of at least 1 kHz.

NOTE: Additional information on accuracy can be found in IEC 62018 [i.6].

- RF output power: $\pm 0,4$ dB.

5.2.1 BS Configuration

The BS shall be tested under normal test conditions according to the information accompanying the equipment. The BS, test configuration and mode of operation (baseband, control and RF part of the BS as well as the software and firmware) shall represent the normal intended use and shall be recorded in the test report.

The BS shall be tested with its typical configuration. In case of multiple configurations a configuration with 3 sectors shall be used. Examples: a typical wide area BS configuration consists of three sectors and shall therefore be tested in a three sector configuration; another BS configuration might be designed for dual or single sector applications and therefore be tested in the configuration of its intended configuration.

The connection to the simulator via the BS controller interface shall be an electrical or optical cable-based interface (e.g. PCM, SDH, and Ethernet) which is commercially offered along with the applied BS configuration. Additional power consuming features like battery loading shall be switched off.

The power saving features and used SW version shall be listed in the measurement report.

The measurement report shall mention the configuration of the BS for example the type of RF signal combining (antenna network combining, air combining or multi-carrier).

5.2.2 RF output (transmit) power/signal

Due to the different nominal RF output power values of the various BS models and additionally their RF output power tolerances within the tolerance ranges defined by the corresponding mobile radio standards, it is necessary to measure the real RF output power at each RF output connector of the BS.

During the test the BS shall be operated with the nominal RF output powers which would be applied in commercial operation regarding the reference networks and the traffic profiles listed in annexes D, E, F, H, K.

The power amplifier(s) of the BS shall support the same crest factor (peak to average ratio) and back-off as applied in the commercial product.

All relevant requirements from the corresponding 3GPP and GERAN specifications for the air-interface, e.g. [2] for WCDMA/HSPA and LTE, shall be fulfilled.

5.2.3 Environmental conditions

For the power consumption measurements the environmental conditions under which the BS has to be tested are defined as follows.

Table 1: BS environmental conditions

Condition	Minimum	Maximum
Barometric pressure	86 kPa (860 mbar)	106 kPa (1 060 mbar)
Relative Humidity	20 %	85 %
Vibration	Negligible	
Temperature	Static: +25 °C and +40 °C Dynamic: +25 °C	
Temperature accuracy	± 2 °C	

The power consumption measurements shall be performed when stable temperature conditions inside the equipment are reached. For this purpose the BS shall be placed in the environmental conditions for minimum two hours with a minimum operation time of one hour before doing measurements.

5.2.4 Power supply

For measurements of the BS power consumption the following operating voltage value shall be used (for non standard power supply voltages one should use operating voltage with $\pm 2,5$ % tolerances).

Nominal value and operating value shall be according for AC testing to [3] and DC testing to [4].

The frequency of the power supply corresponding to the AC mains shall be according to [3].

6 Static power consumption measurement

Power Savings features implemented independently within BS can be used during testing. In that case, test control unit is allowed to activate and deactivate the features. Used features shall be listed in the measurement report.

6.1 Calculation of average static power consumption for integrated BS

The power consumption of integrated BS equipment in static method is defined for three different load levels as follows:

- P_{BH} is the power consumption [W] with busy hour load.
- P_{med} is the power consumption [W] with medium term load.
- P_{low} is the power consumption [W] with low load.

The load levels are defined differently for different radio systems. The model covers voice and/or data hour per hour. The models are provided in the annexes D, E, F, K.

The average power consumption [W] of integrated BS equipment in static method is defined as:

$$P_{equipment,static} = \frac{P_{BH} \cdot t_{BH} + P_{med} \cdot t_{med} + P_{low} \cdot t_{low}}{t_{BH} + t_{med} + t_{low}} \quad (6.1)$$

in which t_{BH} , t_{med} and t_{low} [hour] are duration of different load levels (for details for each different access systems see annexes D, E, F, K).

6.2 Calculation of average static power consumption for distributed BS

The power consumption of distributed BS equipment in static method is defined for three different load levels as follows (for details of load levels see the annexes D, E, F, K):

- $P_{BH,C}$ and $P_{BH,RRH}$ are the power consumption [W] of central and remote parts of BS with busy hour load.
- $P_{med,C}$ and $P_{med,RRH}$ are the power consumption [W] of central and remote parts of BS with medium term load.
- $P_{low,C}$ and $P_{low,RRH}$ are the power consumption [W] of central and remote parts of BS with low load.

The average power consumption [W] of distributed BS equipment is defined as:

$$P_{equipment,static} = P_{c,static} + P_{RRH,static}, \quad (6.2)$$

in which $P_{C,static}$ and $P_{RRH,static}$ [W] are average power consumption of central and remote parts in static method defined as:

$$P_{C,static} = \frac{P_{BH,C} \cdot t_{BH} + P_{med,C} \cdot t_{med} + P_{low,C} \cdot t_{low}}{t_{BH} + t_{med} + t_{low}} \quad (6.3)$$

$$P_{RRH,static} = \frac{P_{BH,RRH} \cdot t_{BH} + P_{med,RRH} \cdot t_{med} + P_{low,RRH} \cdot t_{low}}{t_{BH} + t_{med} + t_{low}} \quad (6.4)$$

in which t_{BH} , t_{med} and t_{low} [hour] are duration of different load levels (for details for each different access system see annexes D, E, F, K). This average power consumption of distributed BS equipment does not include the DC feeder loss for remote parts.

6.3 Measurement method for static BS power consumption

This clause describes the method to measure the equipment performance taking into account the existing standards as listed in the reference lists in clause 2. It also gives the conditions under which these measurements should be performed in addition to the requirements of clause 5.

The BS shall be operated in a test and measuring environment as illustrated in figure 3.

6.3.1 Test setup for power consumption measurement

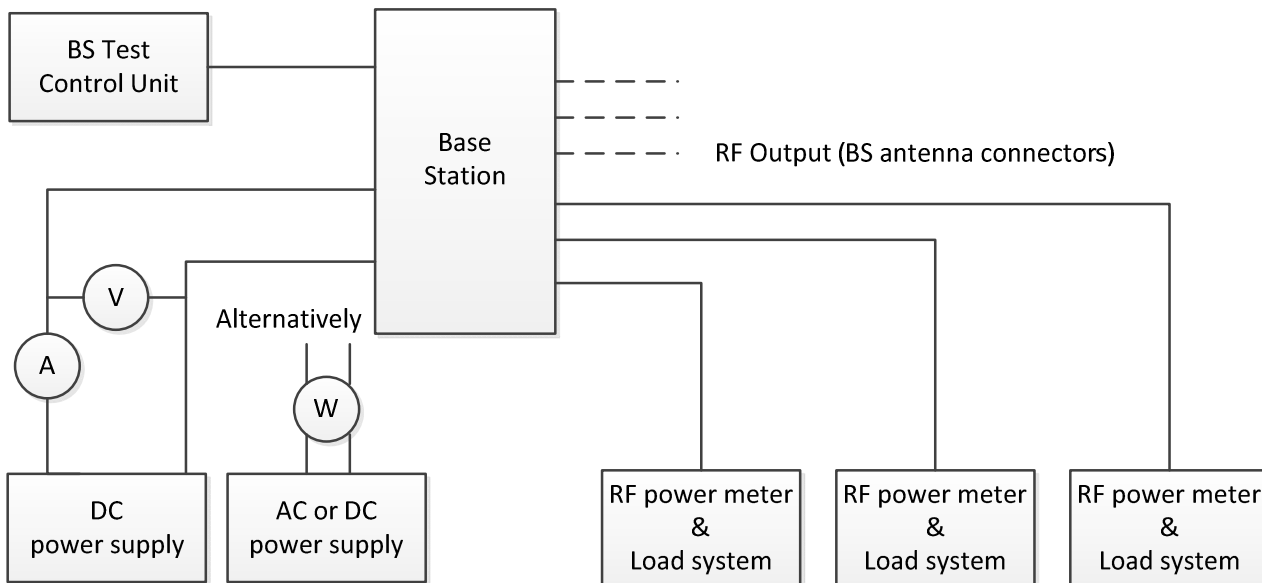

NOTE: BS as defined in figure 2 (Integrated BS) or figure 3 (distributed BS). AC supply to be used for BS with built in AC power supply, otherwise default DC supply voltage as specified in clause 5.2.

Figure 3: Test set-up for power consumption measurements (example for three sectors)

The BS is powered either by a DC or AC power supply and operated by the BS test control unit. This control unit provides the BS with control signals and traffic data which are required to perform the static measurements. Each RF output (antenna) connector is terminated with a dummy load. The RF output power shall be measured at each antenna port and reported in the measurement report.

The BS shall be stimulated via the BS controller interface by the emulation of the test-models in conjunction with the traffic profiles and reference parameters given in annexes D, E, F, K.

6.3.2 Power consumption measurement procedure

The power consumption measurements shall be performed when stable temperature conditions inside the equipment are reached. For this purpose the BS shall be placed in the environmental conditions for minimum two hours with a minimum operation time of one hour before doing measurements according to clause 5.2.3.

Measurement results shall be captured earliest when the equipment including the selected load is in stable operating conditions.

The RF output powers as well as the corresponding power consumptions of the BS shall be measured with respect to the RF output power levels which are needed to fulfil the requirements from the reference networks as well as the traffic profiles described in annexes D, E, F, K.

The RF output power signal and levels shall be generated according to the test models described in annexes D, E, F, K.

The test models as well as the system depended load levels are defined in annexes D, E, F, K.

The reference point for the RF output measurements is the antenna connector of the BS.

The RF output power and corresponding input power consumption shall be measured at the lower, mid and upper edge of the relevant radio band for the low load case. For medium load and busy hour load measurements shall be taken only at middle frequency channel. For the evaluation the single values as well as the arithmetic average of these three measurements (only for low load) shall be stated in the measurement report (table A.3). The arithmetic average shall be taken for BS reference power consumption evaluation.

The measurements shall be performed for every antenna which is carrying downlink antenna carrier(s). The measured RF output power values shall be listed in the measurement report for every antenna.

The power consumption of the BS as well as the RF output power shall be given in watts, in accordance with the accuracies and the resolutions given in clause 5.2.

The measurement expanded uncertainty shall be assessed according to annex J.

7 Dynamic BS energy efficiency measurement

This clause describes the methods to measure the equipment performance taking into account the existing standards as listed in clause 2. It also gives the conditions under which these measurements should be performed.

Dynamic test consist of both capacity and coverage for energy efficiency assessment.

7.1 Test setup for dynamic energy efficiency measurement

For dynamic measurement the BS shall be operated in a test and measuring environment as illustrated in figure 4.

For dynamic BS equipment efficiency measurements the following items are specified for each system in annexes E to H:

- Reference configuration(annexes E and F).
- Frequency bands (annexes E and F).
- Traffic load levels (annex H).
- Traffic case (annex H).

Power Savings features and other radio and traffic related features implemented in BSC/RNC and BS can be used during the testing. Such features shall be listed in the measurement report.

In the dynamic mode the BS is powered by a DC or AC power supply. The control unit itself is connected to the core network. The core network can be either a real network element or a core network simulator. On the antenna interface the BS is connected to all sectors via coaxial cables, see figure 4.

Figure 4 shows the test setup with a three sectors BS. At each sector four UE groups are used. These are connected to variable attenuators to generate different path losses.

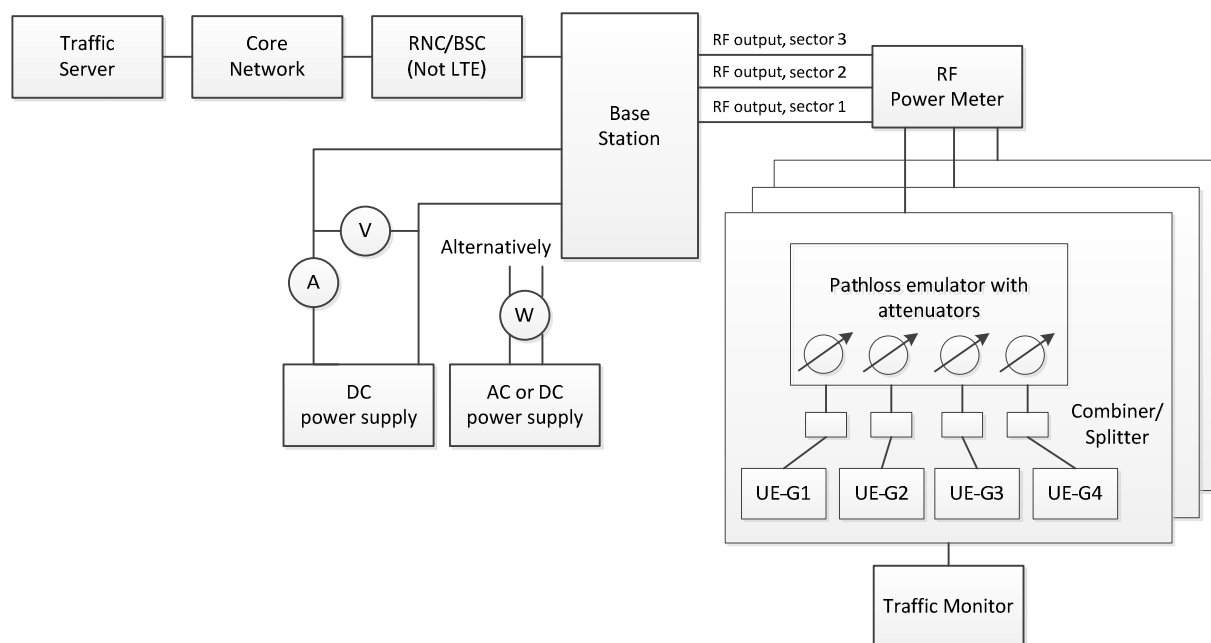

NOTE: BS as defined in figure 2 (compact BS) or figure 3 (distributed BS). AC supply to be used for BS with build in AC power supply, otherwise default DC supply voltage as specified in clause 5.2.

Figure 4: Test setup for dynamic measurement with compact BS and UEs (example for three sectors)

The BS shall be operated via the controller units as illustrated in figure 4 in conjunction with the traffic profiles and reference parameters given in annexes E, F, H.

The UEs are distributed in the cell according to clause 7.2.1 and may be represented either by UE emulators or test mobiles. In either case the performance requirements apply as described in related clause 7.2.2 for each technology.

7.2 Capacity test procedure

This clause describes the measurement method for capacity measurement including the distribution of UEs during measurement and throughput setup.

7.2.1 UE distribution for dynamic test method

In the dynamic test method 4 UE groups are distributed in each sector. The number of UEs in each group is dependent on which radio access technology is used during the test, see annex H. The distribution of UE groups is in a way that UE group1 has the lowest path loss and UE group 4 has the highest path loss, see figure 5.

Each UE group is connected to an attenuator with a specific attenuation emulating the UE's position in the cell to give predefined pathloss as stated in annex H.

Values for received signal strength at each UE with respect to different radio access technology are presented in annex H, table H.2.

Multi-path or other propagation impairments are not considered.

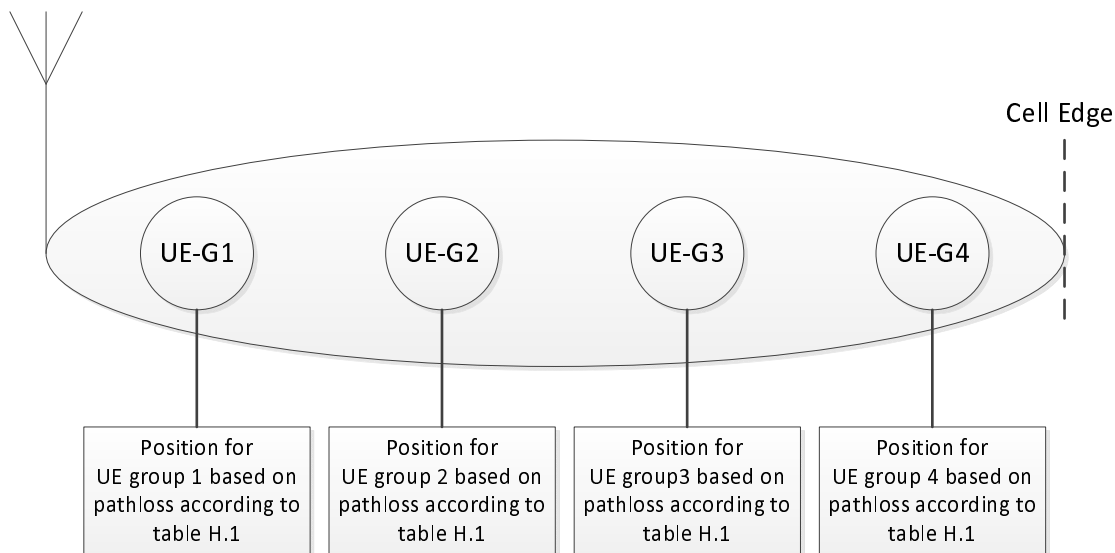

Figure 5: UEs distribution in a sector

7.2.2 UE performance requirements

The dynamic BS energy efficiency testing allows the usage of either user equipment (UE) emulator or a test setup with conventional UEs.

The BS energy efficiency depends to a significant part on the performance of the UE. To achieve comparable results, the UE performance shall be according to the nominal minimum performance as specified in relevant 3GPP standard (for example ETSI TS 125 101 [8] for WCDMA).

Standard off-the-shelf UEs have typically a better performance than the minimum requirements to cope with production tolerances. To minimize the impact of the UEs on the test results, the performance variations have to be compensated. This clause describes a basic set of UE specifications and corrective actions to compensate for UE performance variations for the BS EE test setup.

The downlink capacity test results described in the present document depend on the receiver sensitivity of the UE. UE emulators usually means to calibrate key parameters like transmit power, receiver sensitivity, etc. The following procedure shall guarantee that all UEs used for the test setup match the required minimum performance as specified in the relevant UE standard.

UE Requirements:

- 1) UEs which have an external antenna connector as default shall be used as test device.
- 2) UEs used for testing shall achieve the minimum RF performance according to the relevant standard with an accuracy of $\pm 0,5$ dB.
- 3) Only UEs of power classes 3 and 3bis shall be applied since power classes 1 and 2 are only specified for band 1.
- 4) Only UEs with a significant market penetration (for example models of the actual top ten sales lists, etc.) shall be used.
- 5) The used UE equipment has to be recorded in detail for the test protocol. This shall include origin, H/W and S/W versions of the UEs as well as any modifications or corrective measures made.

The RX sensitivity of the UEs applied shall be measured and corrected before the BS capacity test. The UE sensitivity shall be measured with an UE test setup comprising of a signal generator and BER counter as described in figure 6. The UE sensitivity shall be reduced with an attenuator at the UE antenna port to the reference sensitivity as specified in table 7.2A in [8] and [9]. The measurements shall be done for all UEs used during the test at all frequencies and bandwidths used for efficiency testing.

The correction factors applied shall be documented in the test protocol.

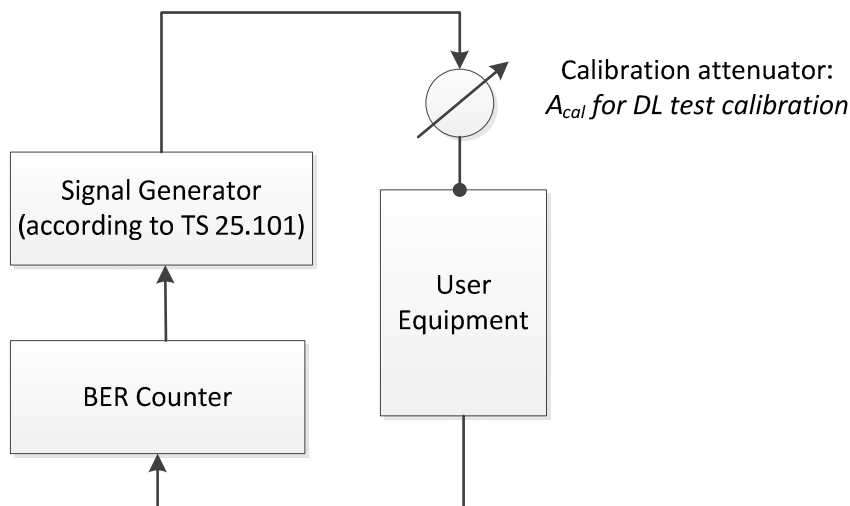

Figure 6: UE calibration setup for UE sensitivity correction

The calibration attenuator shall remain connected to the UE during all capacity tests like shown in figure 6. In the case that only one UE is used per UE group, the required attenuation can be added to the path loss attenuation instead.

7.2.3 Throughput setup

The following procedure is applied for one carrier.

Due to the different link budget conditions UEs at different positions in a sector get different net data transmissions per bit.

In order to equally weight the contribution of different UEs to the global energy efficiency metric, the active UEs shall evenly share the channel resources over their simultaneous active time.

As the test scenario of each duty cycle (T_D) (see annex H) shall be divided in 4 active phases (T_p) (depending if 4, 3, 2 or 1 UE are receiving DL traffic), the even distribution of resources shall be provided in the average during each phase (see clause 7.2.4).

The UDP protocol shall be used for transmitting data traffic.

For each of the different attenuations, the bit rate setting for the UDP traffic (see annex H) generators can be experimentally determined as follows (see figures 7 to 10):

- 1) Start with one connected UE. This UE (e.g. UE4) has the worst link budget conditions. Tune the UDP bit rate to the max value for which the network sends (data rate sent by UDP traffic generator) and receive throughput (maximum net throughput received by UE without data loss) are the same. This value is called $TP_{max_{UE4}}$.
- 2) Connect the next UE. This UE (e.g. UE3) has the second worst link budget. The previous UE(s) remain connected and get its/their data with unchanged UDP traffic generator data rate. Perform the same tuning operation for the new UE (e.g. UE3) as described for previous UE in step (1), but now in contention with the previous UE. This value is called $TP_{max_{UE3}}$.
- 3) Sequentially perform the tuning operation of step (2) for each UE (in order of decreasing attenuation). The bit rate is thus achieved in contention with all UEs that have been tuned so far. These values are called $TP_{max_{UE2}}$ and $TP_{max_{UE1}}$ for UE2 and UE1 respectively.

The UDP data throughputs are now determined and will be used for the energy efficiency test. During test execution, the UDP data generator of each UE will be started and terminated several times according to the activity levels defined in annex H. The implied precondition of the Throughput setup is that UE1 is always in contention with the other UEs; UE2 always in contention with UE3 + UE4; UE3 always in contention with UE4. In any case, the configured bit rate stays fixed to the obtained values.

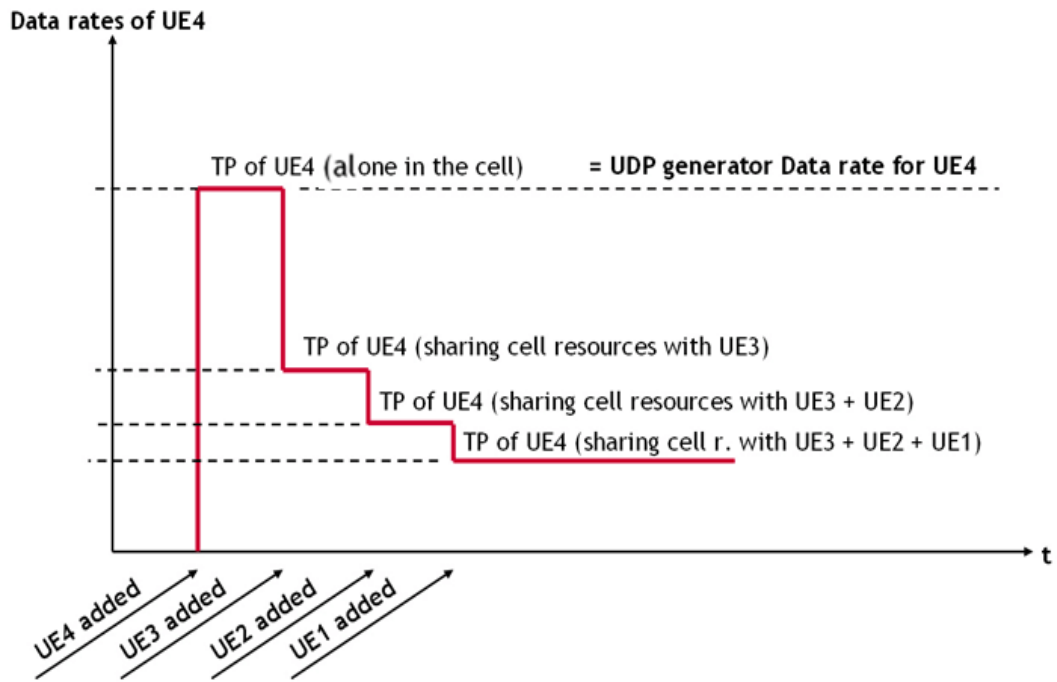

Figure 7: UDP data rate for UE4

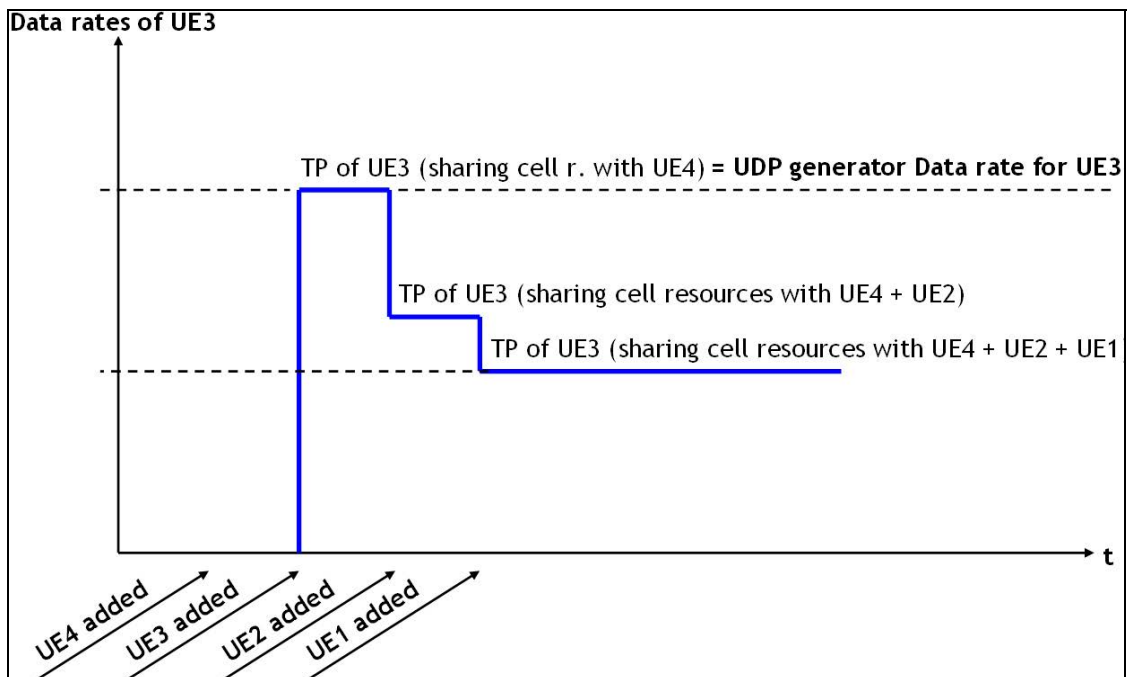

Figure 8: UDP data rate for UE3

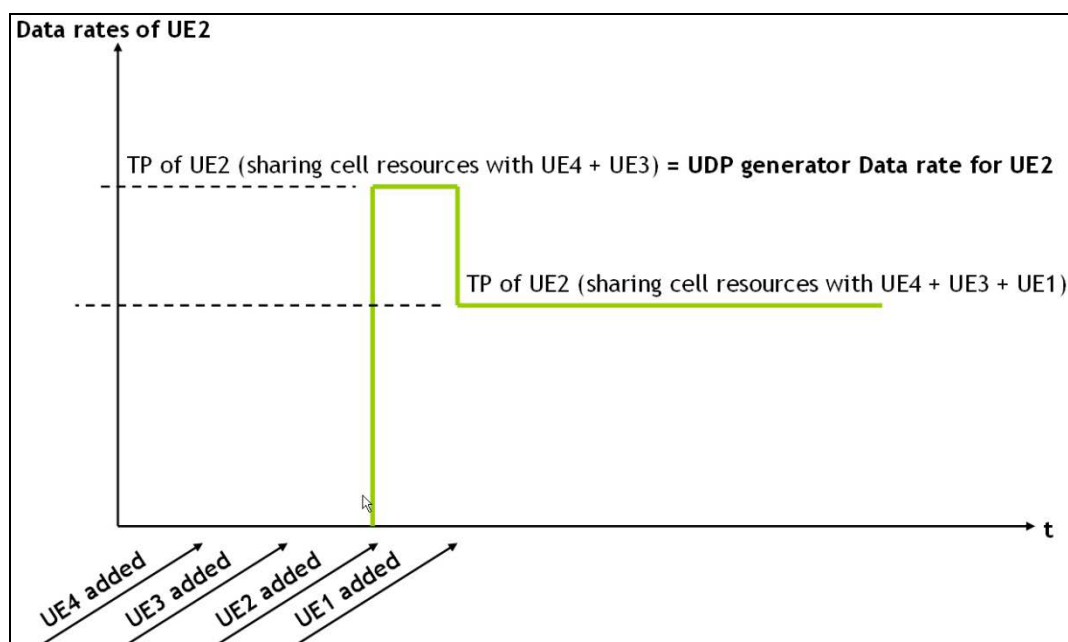

Figure 9: UDP data rate for UE2

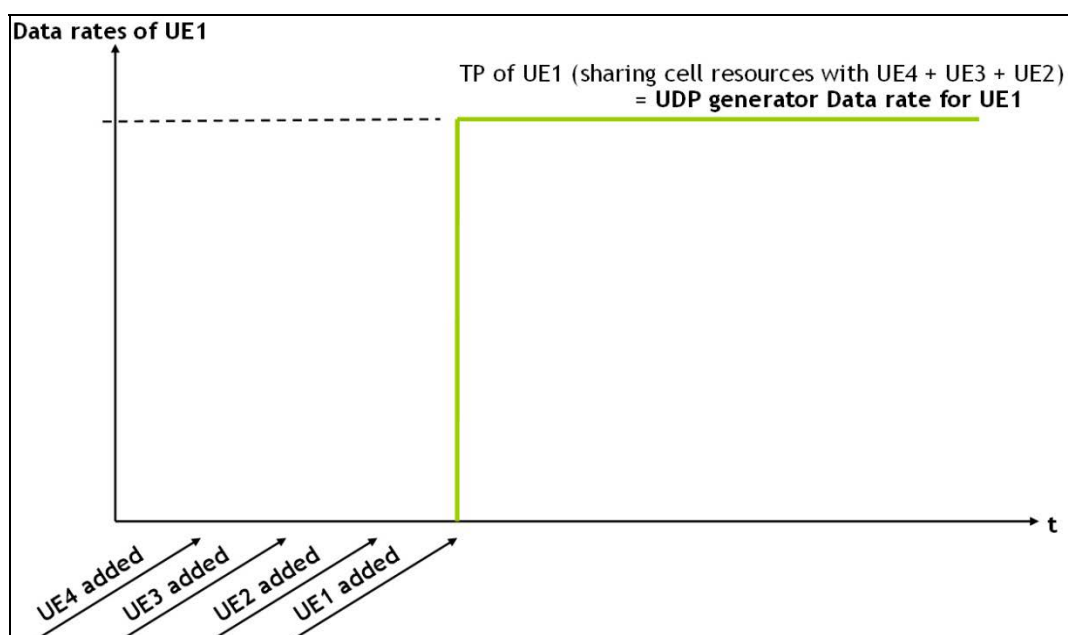

Figure 10: UDP data rate for UE1

7.2.4 Verification of minimum data delivered to UEs

This clause defines the verification of the minimum data the BS has delivered to each UE during the energy efficiency tests.

The amount of **accumulated data per Activity Level** ($\#Data_{x,UEi}$) can be easily compared with the expected minimum data, based on the UDP-levelled Throughput (= measured TPmax) multiplied by the summarized recording time.

The minimum data per Activity Level (and per UE-Group) is the evaluated volume of data, reduced by a tolerance factor TF. Via formula 6.b (see annex L) and with current values i.e. $SF_{UE4} = 25/12$; $SF_{UE3} = 26/12$; $SF_{UE2} = 15/12$; $SF_{UE1} = 12/12$; $n = 10$; $T_D = 40$ s; $M = 4$; $TF = 0,25$ (see annex L for derivation of these values):

Evaluated data volume:

- $\#Data_{x,UEi} \geq TP_{max,UEi} \times 75 \text{ s} \times AF_x$.

- $\#Data_{x,UE2} \geq TP_{max,UE2} \times 131,25 \text{ s} \times AF_x$.
- $\#Data_{x,UE3} \geq TP_{max,UE3} \times 162,5 \text{ s} \times AF_x$.
- $\#Data_{x,UE4} \geq TP_{max,UE4} \times 156,25 \text{ s} \times AF_x$.

The measured $TP_{max,UEi}$ as well as the volume of accumulated data $\#Data_{accu,UEi,x}$ as well as the number of evaluated data $\#Data_{x,UEi}$ have to be mentioned in the Measurement Report (see annex A, table A.7).

7.2.5 Definition of power consumption for integrated BS in dynamic method

The power consumption of integrated BS equipment in dynamic method is defined for three different activity levels as follows:

- P^{AL10} is the power consumption [W] with 10 % activity level.
- P^{AL40} is the power consumption [W] with 40 % activity level.
- P^{AL70} is the power consumption [W] with 70 % activity level.

The activity levels are defined for a given system. The models are provided in annex H.

7.2.6 Definition of power consumption for distributed BS in dynamic method

The power consumption of distributed BS equipment in dynamic method is defined for three different activity levels as follows (for details of activity levels see annex H):

- $P^{AL10}_{,C}$ and $P^{AL10}_{,RRH}$ are the power consumption [W] of central and remote parts of BS with 10 % activity level.
- $P^{AL40}_{,C}$ and $P^{AL40}_{,RRH}$ are the power consumption [W] of central and remote parts of BS with 40 % activity level.
- $P^{AL70}_{,C}$ and $P^{AL70}_{,RRH}$ are the power consumption [W] of central and remote parts of BS with 70 % activity level.

7.2.7 Energy efficiency for WCDMA and LTE

To calculate the energy efficiency indicator in dynamic mode for the x^{th} activity level, the power consumption of the BS is sampled continuously (interval time Δt_m : 0,5 seconds or shorter) over the complete period T_D of the test patterns (duty cycle period). For the integrated BS, $P_{i,k, \text{equipment}}^{ALx}$ is the measurement value for the i^{th} measurement regarding the k^{th} duty cycle period and the x^{th} activity level. The test patterns are repeated n times where n is the total number of duty cycles during the test as defined in annex H. The average energy $E_{\text{equipment}}^{ALx}$ which is consumed by the BS during one duty cycle period and for the x^{th} activity level is evaluated as follows:

$$E_{\text{equipment}}^{ALx} = \frac{1}{n} \cdot \sum_{k=1}^n \left(\Delta t_m \cdot \sum_{i=1}^{T_D / \Delta t_m} P_{i,k, \text{equipment}}^{ALx} \right) \quad \text{[J]} \quad (7.1)$$

$T_D / \Delta t_m$ shall be an integer.

For the distributed BS case $E_{C, equipment}$ and $E_{RRH, equipment}$ [J] are the average energy consumption of the central and the remote parts in the dynamic method for the x^{th} activity level defined as:

$$E_{RRH, equipment}^{ALx} = \frac{1}{n} \cdot \sum_{k=1}^n \left(\Delta t_m \cdot \sum_{i=1}^{T_D / \Delta t_m} P_{RRH, i, k, equipment}^{ALx} \right) \quad \text{[J]} \quad (7.2)$$

$$E_{C, equipment}^{ALx} = \frac{1}{n} \cdot \sum_{k=1}^n \left(\Delta t_m \cdot \sum_{i=1}^{T_D / \Delta t_m} P_{C, i, k, equipment}^{ALx} \right) \quad \text{[J]} \quad (7.3)$$

The average net data volume DV^{ALx} during one duty cycle period and x^{th} activity level is determined as given in the following equation):

$$DV^{ALx} = \frac{1}{n} \cdot \sum_{k=1}^n \left(\sum_{j=1}^m DV_{j, k}^{ALx} \right) \quad \text{[kbit]} \quad (7.4)$$

where m is the total number of UEs which are connected to the BS and $DV_{j, k}^{ALx}$ the net data volume for the j^{th} UE regarding the k^{th} duty cycle period and x^{th} activity level. Net data volume is the amount of data, successfully received at the UE.

The efficiency indicator $EE_{equipment}^{ALx}$ for x^{th} activity level is then calculated as follows:

$$EE_{equipment}^{ALx} = \frac{DV^{ALx}}{E_{equipment}^{ALx}} \quad \text{[kbit/J]} \quad (7.5)$$

The measurements are carried out for all defined activity levels which are given in annex H.

In order to obtain the global efficiency indicator $EE_{equipment}$, the net data volume and energy consumption for the different activity levels have to be added taking the corresponding weighting factors c_{ALx} . The weighting factor considers the daily distribution of the traffic during the day, see annex H for the standard distribution proposed. l is the total number of activity levels. The global efficiency indicator $EE_{equipment}$ is then calculated as follows:

$$EE_{equipment} = \frac{\sum_{ALx=1}^l c_{ALx} \cdot DV^{ALx}}{\sum_{ALx=1}^l c_{ALx} \cdot E_{equipment}^{ALx}} \quad \text{[kbit/J]} \quad (7.6)$$

In which, $\sum_{ALx=1}^l c_{ALx} \cdot DV^{ALx}$ are total average data volume considering the daily distribution of traffic levels,

$\sum_{ALx=1}^l c_{ALx} \cdot E_{equipment}^{ALx}$ are total average energy consumption considering the daily distribution of traffic levels.

7.2.8 Energy efficiency for GSM

To be developed in the later version.

7.3 Coverage efficiency test procedure

In rural areas, the dominant factor for the dimensioning of a network is the coverage area. The traffic demand is typically smaller than the maximum possible capacity of the BS and thus the cell size is defined by the propagation model. Thus, the energy efficiency for rural area is defined as follows where the *KPI* in the formula (7.7) is the area the BS can cover from radio coverage point of view:

$$EE_{coverage} = \frac{A_{coverage}}{P_{BS}} \text{ [km}^2\text{/W]} \quad (7.7)$$

$A_{coverage}$ is the BS coverage area [km²] for rural area. The coverage area is calculated based on both uplink and downlink systems values (for details on how to calculate system values and cell radius see annex C). The limiting value of uplink and downlink coverage areas shall be used. Both coverage areas are calculated under low traffic load situation. For downlink calculation the BS BCCH signal power level and UE receiver sensitivity and traffic type defined in annex D shall be used. For uplink calculation the measured BS receiver sensitivity with UE transmission power and traffic type defined in annex D shall be used.

The energy efficiency for coverage ($EE_{coverage}$) is measured and calculated under the following conditions:

- Apply BS test generator (UE emulator).
- Measure the sensitivity of the BS (with one RX path, other RX path for UL diversity shall be active but antenna connector terminated) as well as the power consumption P of the BS with all sectors active and commissioned identically. A test generator shall be connected to one sector only.

The sensitivity shall be measured for the uplink throughput as specified below:

- WCDMA/Rel.99: Speech call with 12,2 kbps AMR.
The Bit Error Rate (BER) shall be $\leq 0,001$ as defined in ETSI TS 125 141 [7] and annex C.
- WCDMA/HSDPA: upload via UDP with a net data throughput not less than 256 kbps.
- LTE: upload via UDP with a net data throughput not less than 500 kbps.

After the UL requirements have been fulfilled the downlink throughput shall be configured to the following requirements:

- WCDMA/Rel.99: Speech call with 12,2 kbps AMR.
The Bit Error Rate (BER) shall be $\leq 0,001$ as defined in ETSI TS 125 141 [7] and annex C.
- WCDMA/HSDPA: download via UDP with a net data throughput not less than 1 280 kbps.
- LTE: download via UDP with a net data throughput not less than 2 500 kbps.

Ciphering shall be activated on the air-interface.

Measurement setup:

- 1) (e)NodeB: 1+1+1 configuration; 40 W rated output power per transmitter or the maximum of BS output power if 40 W is not reached; no TX-diversity in WCDMA/MIMO configuration in LTE activated but one antenna connector terminated.
- 1) Frequency bands as defined in annex E for WCDMA and annex F for LTE.
- 2) Common channels (all 3 sectors) as defined in annex E for WCDMA and annex F for LTE.
- 3) (e)NodeB from commercial production, commercial SW, default adjustments for RNC/SAE and (e)NodeB.

The coverage area is calculated from the measured path loss as specified in annex C.

7.4 Uncertainty

The measurement expanded uncertainty shall be assessed according to annex J.

8 Measurement report

The results of the assessments shall be reported accurately, clearly, unambiguously and objectively, and in accordance with any specific instructions in the required method(s).

A list of reference parameters, measurement conditions, test results, **uncertainty analysis (cf. annex J)** and derived calculation results which are to be reported is given in annex A.

Further guidelines on the test report can be found in clause 5.10 of ISO/IEC 17025 [i.4].

Annex A (normative): Test Reports

A.1 General information to be reported

Table A.1: Test general information

Items	Remarks
1) test report reference and version	
2) Date of the test	
3) Standard Used as test methodology	
4) Location of the test	
5) Name of test organization and responsible person	
6) Tested equipment	
6.1) Tested HW unit names and serial numbers	
6.2) Software version of tested equipment	
7) List of used measurements equipments including type, serial number and calibration information	

Table A.2: BS reference parameters to be reported

Parameter	Value	Unit
1) BS configuration		
1.1) Number of sectors		
1.2) Nominal max RF output power per sector		W
1.3) Number of Carriers per sector		
1.3.1) Number of carriers the BS is able to support		
1.3.2) Number of carriers, for which the HW was enabled (independent whether or not the carriers were used for the test)		
1.3.3) Number of carriers used during the test		
1.4) TX diversity		
1.5) RX diversity,(number)		
1.6) Type of RF signal combining		
1.7) Remote Radio Head (Yes/No)		
2) Frequency		
2.1) Downlink band		MHz
2.2) Uplink band		MHz
2.3) Channel bandwidth		MHz
3) Environment		
3.1) Temperature range		°C
3.2) Type of air filter		
4) Features		
4.1) Power saving features		
4.2) Coverage and capacity features		
4.3) Downlink ciphering used? (Y/N)		

A.2 Static power consumption report

Table A.3: Measurements conditions and results to be reported for static power consumption

Parameter	Test case 25 °C	Test case 40 °C	Unit
1) Test environment			
1.1) Temperature during test (measured)			°C
1.2) Pressure (measured)			kPa
1.3) Relative humidity (measured)			%
2) Frequency used at test			
2.1) downlink Centre frequency of low end channel			MHz
2.2) downlink Centre frequency of middle channel			MHz
2.3) downlink Centre frequency of high end channel			MHz
2.4) Uplink Centre frequency of middle channel			MHz
3) Supply voltage			
3.1) DC voltage (measured)			V
3.2) AC voltage (measured, phase to neutral)			V
3.3) AC Frequency (measured)			Hz
4) Static power consumption (measured)			
4.1) Busy hour load, Middle frequency channel			W
4.2) Medium load, Middle frequency channel			W
4.3) Low load			
4.3.1) Low end frequency channel			W
4.3.2) Middle frequency channel			W
4.3.3) High end frequency channel			W
4.3.4) Average consumption with low load			W
5) TX output power (pilot signal only)			
5.1) Output power at low end channel			W
5.2) Output power at middle end channel			W
5.3) Output power at high end channel			W
5.4) Average output power per sector			W
6) RX receiver sensitivity at middle channel			dBm
7) Expanded uncertainty			%

The measurement report shall include the uncertainty table following the template defined in table J.1.

Table A.4: Calculation results to be reported for static power consumption

Parameter	Value	Unit
1) $P_{\text{equipment}}$ of integrated BS power consumption at 25 °C		W
2) $P_{\text{equipment}}$ of integrated BS power consumption at 40 °C		W
3) $P_{\text{equipment}}$ of distributed BS power consumption at 25 °C		W
3.1) $P_{\text{equipment}}$ of distributed BS power consumption at 25 °C for central part		W
3.2) $P_{\text{equipment}}$ of distributed BS power consumption at 25 °C for remote part		W
4) $P_{\text{equipment}}$ of distributed BS power consumption at 40 °C		W
4.1) $P_{\text{equipment}}$ of distributed BS power consumption at 40 °C for central part		W
4.2) $P_{\text{equipment}}$ of distributed BS power consumption at 40 °C for remote part		W

Table A.5: Measurements conditions and results to be reported for dynamic efficiency

Parameter	Test case 25 °C	Unit
1) Test environment		
1.1) Temperature during test (measured)		°C
1.2) Pressure (measured)		kPa
1.3) Relative humidity (measured)		%
2) Frequency used at test		
2.1) Downlink Centre frequency of low end channel		MHz
2.2) Downlink Centre frequency of middle channel		MHz
2.3) Downlink Centre frequency of high end channel		MHz
2.4) Uplink Centre frequency of middle channel		
3) Supply voltage		
3.1) DC voltage (measured)		V
3.2) AC voltage (measured, phase to neutral)		V
3.3) AC Frequency (measured)		Hz
4) Dynamic energy consumption (measured)		
4.1) 70 % activity level		J
4.2) 40 % activity level		J
4.3) 10 % activity level		J
5) Average measured data volume		
5.1) 70 % activity level		kbit
5.2) 40 % activity level		kbit
5.3) 10 % activity level		kbit
6) Measure path loss coverage test		dB

Table A.6: Calculated results to be reported for dynamic efficiency

Parameter	Value	Unit
1) Total downlink throughput during the test		kbit
2) Total energy consumption		J
3) Coverage		km ²
4) Energy Efficiency for capacity		kbit/J
5) Energy efficiency for coverage		km ² /W
6) Expanded uncertainty		%

The measurement report shall include the uncertainty table following the template defined in table J.2.

Table A.7: UE reporting table for UE at position

Item	Value	Remarks	Unit
UE Position			
Antenna attenuator for DL test		<i>value of sensitivity and power correction attenuators as specified in section UE requirements</i>	dB
Antenna attenuator for UL test		<i>value of sensitivity and power correction attenuators as specified in section UE requirements</i>	dB
Standard antenna connector for UE(i) (Yes/NO)			
The UE type at position <i>i</i>			
The maximum throughput $TP_{max,UEi}$			kbit
The estimated volume of data, $\#data_{AL1,UEi}$			kbit
The estimated volume of data, $\#data_{AL2,UEi}$			kbit
The estimated volume of data, $\#data_{AL3,UEi}$			kbit
The measured volume of data, $\#data_{accumulatedAL1,UEi}$			kbit
The measured volume of data, $\#data_{accumulatedAL2,UEi}$			kbit
The measured volume of data, $\#data_{accumulatedAL3,UEi}$			kbit
Category		smart phone, data card, etc.	
HW version			
Location ID		identify sector and group in the test setup	
Manufacturer			
Maximum specified DL data rate		according to manufacturer data sheet	kbps
Maximum specified UL data rate		according to manufacturer data sheet	kbps
Model name			
Modifications		modifications of UE should be avoided	
Origin		source and date of purchase	
Serial number			
SW version			

Annex B:
Void

Annex C (normative): Coverage area definition

This annex presents a method to define BS coverage area.

The maximum path loss for downlink L_{Pd} and uplink L_{Pu} shall be calculated based on the downlink and uplink service requirement of voice and data:

For downlink:

$$L_{Pd} = P_{Btx} - L_{Bcom} - L_{Bf} + G_{Ba} + G_{Ma} - L_{In} - L_{Ph} - P_{Msen} - P_{margin} \quad (C.1)$$

For uplink:

$$L_{Pu} = P_{Mtx} - L_{Ph} + G_{Ma} + G_{Ba} - L_{Bf} - P_{Bsen} - P_{margin} - L_{In} \quad (C.2)$$

Okumura-Hata model is the most widely used model in radio frequency propagation for macro BS (rural area model). The path loss is described by:

$$L_p = 69,55 + 26,16 \lg f - 13,82 \lg h_b - a(h_m) + (44,9 - 6,55 \lg h_b) * \lg d + C \quad (C.3)$$

$$a(h_m) = (1,1 \lg f - 0,7) h_m - (1,56 \lg f - 0,8)$$

$C = 0$ dB for medium sized cities and suburban centres with moderate tree density;

Where L_{Bf} , Feeder loss factor, including losses of feeder, jumpers and connectors:

- Standard Macro BS site configuration: UL/DL loss is 3,0 dB.
- For Distributed BS with remote radio head at tower, UL/DL jumper loss is 0,5 dB.

Formula (C.3) can be written as (C.4) where A is the fixed attenuation in Okumura-Hata model. This model can be used for rough estimation of the size of macrocells, without respect to specific terrain features in the area. The validity of the formula C.4 is the same as for the Hata model, except that the frequency range has been stretched up to 2,6 GHz in table C.1. Depending on value for A the formula (C.4) gives different pathloss for different frequencies stated in table C.1.

The values of A for different frequency band can be found in table C.1.

$$L_p = A - 13,82 \lg h_b - a(h_m) + (44,9 - 6,55 \lg h_b) * \lg d \quad (C.4)$$

Table C.1: Fixed attenuation A in Okumura-Hata propagation model

Frequency (MHz)	700	850	900	1 700	1 800	1 900	2 100	2 600
Attenuation A (dB)	144,0	146,2	146,8	154,1	154,7	155,3	156,5	158,9

Resolving (C4) according d gives the radius of the coverage area:

$$d = 10^{\frac{L_p - A + 13,82 \lg h_b + a(h_m)}{44,9 - 6,55 \lg h_b}} \quad (C.5)$$

The coverage area can be calculated as following:

$$Coverage_Area = \frac{9 \cdot \sqrt{3} \cdot d^2}{8} \quad (C.6)$$

Table C.2: Propagation and path loss parameters

Parameters	Definition	Value
A	Fixed attenuation factor	According to table C.1
d	The cell radius	According to formula C3
f	The used frequency	
GBa	BS antenna gain [dBi]	17,5
GMa	UE antenna gain [dB]	According to annexes D, E, F
Hb	BS antenna height [m]	40
Hm	UE antenna height [m]	According to annexes D, E, F
LBcom	BS combiner loss [dB]	Measured according to annexes D, E, F
LBf	BS feeder and connector loss [dB]	Integrated BS: 3,0 dB, Distributed BS: 0,5 dB
L _p	Path loss in Okumara-Hata model	Measured value in dB
LPh	Body loss	3 dB for voice services / 0 dB for data services
PBsen	BS sensitivity [dBm]	Measured according to annexes D, E, F 3 dB RX-Div. gain shall be included here as well
PBtx	BS transmit power [dBm]	Measured according to annexes D, E, F
Pmargin	Shadow fading margin [dB]	6
Lin	Indoor loss (dB)	12
PMsen	UE sensitivity [dBm]	According to annexes D, E, F
PMtx	UE transmit power [dBm]	According to annexes D, E, F

Annex D (normative): Reference parameters for GSM/EDGE system

Reference configurations for GSM/EDGE:

- Number of sectors and carriers: 222 (2 carriers per sector, 3 sectors), 444, 888.
- Power Input: -48 V DC, +24 V DC, 230 V AC.
- Nominal TX power to be used for TS with user traffic.
- RF output power level: Applicable range from 3 W to 100 W.

GSM load model:

The test model is derived from measurements used in clause 6.5.2 of ETSI TS 151 021 [i.5] and defines the RF output composition as shown in table D.1 and figure D.1.

For Multi Carrier Power Amplifier (MCPA) the carrier spacing shall be equidistant over the specified bandwidth. The used carrier spacing and total bandwidth shall be stated in measurement report.

Load allocation rules for:

- Busy hour load: the active time slots are equally distributed over all TRX required for the relevant test case (222, 444, 888).
- Medium and low load: the number of active TRX can be optimized with the help of energy saving features available in the BS.

Table D.1: Load model for GSM

	Low load	Medium load	Busy hour load
Load for 222	BCCH: Figure D.1 Other TRX: Idle	BCCH: Figure D.1 Other TRX: idle.	BCCH: Figure D.1 (TRX 1) Other TRX: 2 active TS per each sector at static power level. Other TS idle.
Load for 444	BCCH: Figure D.1 Other TRX: Idle	BCCH: Figure D.1 Other TRX 6 active TS per each sector at static power level. Other TS idle.	BCCH: Figure D.1 (TRX 1) Other TRX 12 active TS per each sector at static power level. Other TS idle.
Load for 888	BCCH: Figure D.1 Other TRX: Idle	BCCH: Figure D.1 Other TRX 18 active TS per each sector at static power level. Other TS idle.	BCCH: Figure D.1 (TRX 1) Other TRX 36 active TS per each sector at static power level. Other TS idle.
Load level duration	6 hours	10 hours	8 hours

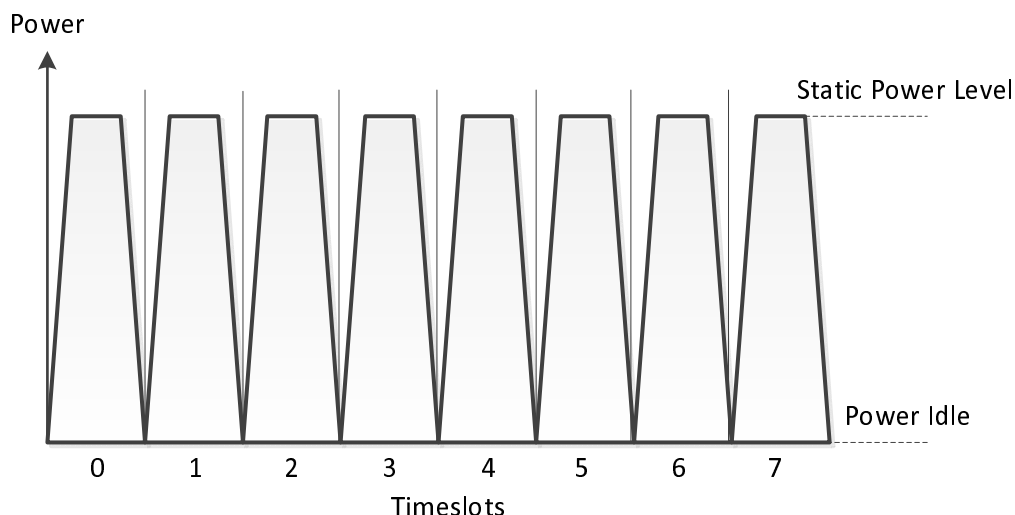

Figure D.1: Power levels for BCCH TRX (all TS active)

Model for GSM subscriber and busy hour traffic:

- CS voice traffic: 0,020 Erlangs/subscriber during Busy Hour.

Table D.2: Busy hour traffic for GSM site

Model for busy hour average traffic load according to table D.1	Busy hour traffic
S222	18 Erlangs (3x6)
S444	51 Erlangs (3x17)
S888	123 Erlangs (3x41)

Frequency bands for GSM/EDGE:

The frequency band shall be as defined in ETSI TS 145 005 [i.3] and according to equipment specifications. For measurement centre frequency of the specified band is used as a reference unless otherwise specified.

Reference parameter for GSM cell size calculation:

Table D.3

Parameter	
BS combiner loss [dB]	3 dB for single carrier PA ,0 dB for MCPA
UE antenna height	1,5 m
UE antenna gain	0 dB
UE sensitivity	According to 3GPP requirements for the tested band [8]
UE RF output power	31 dBm (900 MHz) 28 dBm (1 800 MHz) (minimum 3GPP requirements)
BS transmit power for downlink	BCCH TRX power level
Downlink traffic type	Voice
Uplink traffic type	Voice

Annex E (normative): Reference parameters for WCDMA/HSDPA system

Reference configurations for WCDMA/HSDPA shall be:

- Number of sectors and carriers: 111.
- Channel capacity: Able to handle busy hour traffic + extra 50 %.
- RF output power level:
 - Power Range applicable to the "Wide Area BS" class as defined in ETSI TS 125 104 [2].
 - Maximum nominal RF output power at antenna connector according to product specification.
- Power Input: -48 V DC, 230 V AC.

WCDMA/HSDPA static load model:

The test model shall be according ETSI TS 125 141 [7], clause 6.1.1.1, Test Model 1. For RF output powers below 100 %, only a dedicated number of codes out of 64 (counted from top of the table) shall be used to generate the desired RF-load as stated in table E.1.

For a RF load of 50 %, only the first 15 codes listed in Test Model 1 shall be applied (DPCH power: 27,8 %).

For a RF load of 30 % only the first 3 codes shall be applied (DPCH power: 7,53 %).

Regarding a RF load of 10 % only the "Primary CPICH" shall be activated.

The DPCH power given above is relative to the maximum output power on the TX antenna interface under test. CCH contains P-CCPCH+SCH, Primary CPICH, PICH and S-CCPCH (including PCH (SF=256)).

Table E.1: Load model for WCDMA/HSDPA

	Low load (10 %)	Medium load (30 %)	Busy hour load (50 %)
RF load for 111 per cell	Only Primary CPICH	CCH + first 3 codes	CCH + first 15 codes
Load level duration	6 hours	10 hours	8 hours

Coverage measurement setup configuration:

- WCDMA/HSDPA according to ETSI TS 125 141 [7], clause 6.1.1.4A, Test model "5" (P-CCPCH+SCH, Primary).
- CPICH, PICH, S-CCPCH (containing PCH (SF=256)).

Frequency bands for WCDMA/HSDPA:

The frequency band shall be as defined in ETSI TS 145 005 [i.3] and according to equipment specifications. For measurement centre frequency of the specified band is used.

Reference parameter for WCDMA/HSDPA cell size calculation:

Table E.2

Parameter	
BS combiner loss[dB]	0 dB
UE antenna height	1,5 m
UE antenna gain	0 dB
UE sensitivity	According to 3GPP requirements for the tested band [8]
Downlink traffic type	Data
Uplink traffic type	Data

Annex F (normative): Reference parameters for LTE system

Reference configurations for LTE shall be:

- Only normal cyclic prefix is used.
- PBCH shall be transmitted.
- PDCCH REG EPRE and PDSCH PRB P_A shall be used as defined in TM1.1.
- Usage of PDSCH PRBs and PSS & SSS & PBCH can overlap for medium load and busy hour load.
- PDCCH CCE allocation can be selected freely for medium load and busy hour load.
- Number of sectors and transmitters:
 - 111 (1 TX, 2 RX-paths per sector, SIMO);
 - 111 (1 carrier, 2 TX, 2 RX-paths per sector, MIMO);
 - Carrier bandwidth: 10 MHz and 20 MHz shall be tested.
- No other physical channels and signals (e-pdcch, prs, csi-rs, ue specific rs, etc.) are transmitted.
- RF output power level:
 - Power Range applicable to the "Wide Area BS" class as defined in ETSI TS 136 104 [12].
 - Maximum nominal RF output power at antenna connector according to product specification and according to the load levels (Output power at antenna connector = load model based percentage * Maximum nominal RF output power) measured at the antenna connector according to ETSI TS 136 141 [11].
- Power Input:
 - -48 V DC, 230 V AC.

LTE static load model:

The test model shall be according ETSI TS 136 141 [11] (V8.6.0), clause 6.1.1.1, Test Model E-TM1.1, with following adaptations:

- **For low load:**
All REs dedicated to PCFICH, reference- and synchronization signals shall be transmitted (as TM1.1). REs dedicated to PDCCH, PHICH and PDSCH shall not be transmitted.
- **For medium load:**
All REs dedicated to PCFICH, reference- and synchronization signals shall be transmitted (as TM1.1). REs dedicated to PDCCH, PHICH and PDSCH shall be limited as following:
 - Only a certain number of PRBs dedicated to PDSCH shall be transmitted. The number of transmitted PRBs dedicated to PDSCH shall be calculated as such, for 10 MHz bandwidth 15 PRBs and 20 MHz bandwidth 30 PRBs.
 - As for the PDSCH, the amount of transmitted control channel resources shall be such that the power of the first OFDM symbol within each sub-frame accounts approximately for an average value of 30 % of the maximum rated power of the cell. This corresponds to a fixed PDCCH pattern of 72 transmitted REs at 10 MHz and 144 REs at 20 MHz.
 - REs dedicated to PHICH shall not be transmitted.

- **For busy hour load:**

All REs dedicated to PCFICH, reference- and synchronization signals shall be transmitted (as TM1.1).
REs dedicated to PDCCH, PHICH and PDSCH shall be limited as following:

- Only a certain number of PRBs dedicated to PDSCH shall be transmitted. The number of transmitted PRBs dedicated to PDSCH shall be calculated as such, for 10 MHz bandwidth 25 PRBs and for 20 MHz bandwidth 50 PRBs.
- As for the PDSCH, the amount of transmitted control channel resources shall be such that the power of the first OFDM symbol within each sub-frame accounts approximately for an average value of 50 % of the maximum rated power of the cell. This corresponds to a fixed PDCCH pattern of 144 transmitted REs at 10 MHz and 288 REs at 20 MHz.
- REs dedicated to PHICH shall not be transmitted.

Table F.1: Load model for LTE

	Low load	Medium load	Busy hour load
RF load for 111 (1 TX, 2 RX-paths per sector, SIMO), at 10 MHz	All REs dedicated to PCFICH, reference- and synchronization signals shall be transmitted. REs dedicated to PDCCH, PHICH and PDSCH shall not be transmitted.	All REs dedicated to PCFICH, reference- and synchronization signals shall be transmitted. REs dedicated to PHICH shall not be transmitted. For the PDCCH, 72 further REs shall be transmitted within the first OFDM symbol of each sub-frame. In addition a certain number of PRBs dedicated to PDSCH shall be transmitted. The number of transmitted PRBs dedicated to PDSCH shall be 15 PRBs.	All REs dedicated to PCFICH, reference- and synchronization signals shall be transmitted. REs dedicated to PHICH shall not be transmitted. For the PDCCH, 144 further REs shall be transmitted within the first OFDM symbol of each sub-frame. In addition a certain number of PRBs dedicated to PDSCH shall be trans-mitted. The number of trans-mitted PRBs dedicated to PDSCH shall be 25 PRBs.
RF load for 111 (1 TX, 2 RX-paths per sector, SIMO), at 20 MHz	All REs dedicated to PCFICH, reference- and synchronization signals shall be transmitted. REs dedicated to PDCCH, PHICH and PDSCH shall not be transmitted.	All REs dedicated to PCFICH, reference- and synchronization signals shall be transmitted. REs dedicated to PHICH shall not be transmitted. For the PDCCH, 144 further REs shall be transmitted within the first OFDM symbol of each sub-frame. In addition a certain number of PRBs dedicated to PDSCH shall be transmitted. The number of transmitted PRBs dedicated to PDSCH shall be 30 PRBs.	All REs dedicated to PCFICH, reference- and synchronization signals shall be transmitted. REs dedicated to PHICH shall not be transmitted. For the PDCCH, 288 further REs shall be transmitted within the first OFDM symbol of each sub-frame. In addition a certain number of PRBs dedicated to PDSCH shall be trans-mitted. The number of trans-mitted PRBs dedicated to PDSCH shall be 50 PRBs.
RF load for 111 (1 carrier, 2 TX, 2 RX-paths per sector, 2x2 MIMO), at 10 MHz	All REs dedicated to PCFICH, reference- and synchronization signals shall be transmitted. REs dedicated to PDCCH, PHICH and PDSCH shall not be transmitted.	All REs dedicated to PCFICH, reference- and synchronization signals shall be transmitted. REs dedicated to PHICH shall not be transmitted. For the PDCCH, 72 further REs shall be transmitted within the first OFDM symbol of each sub-frame. In addition a certain number of PRBs dedicated to PDSCH shall be transmitted. The number of transmitted PRBs dedicated to PDSCH shall be 15 PRBs.	All REs dedicated to PCFICH, reference- and synchronization signals shall be transmitted. REs dedicated to PHICH shall not be transmitted. For the PDCCH, 144 further REs shall be transmitted within the first OFDM symbol of each sub-frame. In addition a certain number of PRBs dedicated to PDSCH shall be transmitted. The number of transmitted PRBs dedicated to PDSCH shall be 25 PRBs.
RF load for 111 (1 carrier, 2 TX, 2 RX-paths per sector, 2x2 MIMO), at 20 MHz	All REs dedicated to PCFICH, reference- and synchronization signals shall be transmitted. REs dedicated to PDCCH, PHICH and PDSCH shall not be transmitted.	All REs dedicated to PCFICH, reference- and synchronization signals shall be transmitted. REs dedicated to PHICH shall not be transmitted. For the PDCCH, 144 further REs shall be transmitted within the first OFDM symbol of each sub-frame. In addition a certain number of PRBs dedicated to PDSCH shall be transmitted. The number of transmitted PRBs dedicated to PDSCH shall be 30 PRBs.	All REs dedicated to PCFICH, reference- and synchronization signals shall be transmitted. REs dedicated to PHICH shall not be transmitted. For the PDCCH, 288 further REs shall be transmitted within the first OFDM symbol of each sub-frame. In addition a certain number of PRBs dedicated to PDSCH shall be trans-mitted. The number of transmitted PRBs dedicated to PDSCH shall be 50 PRBs.
Load level duration	6 hours	10 hours	8 hours

Coverage measurement setup configuration:

- Bandwidth: 20 MHz or less.
- The reference signals (RS), Synchronization signals (SCH), control channels (PBCH, PCFICH, PHICH, PDCCH) and shared channel (PDSCH), have to be configured and processed the same way as done for the capacity measurements of the dynamic load model.

Frequency bands for LTE:

The frequency band shall be as defined in ETSI TS 145 005 [i.3] and according to equipment specifications. For measurement centre frequency of the specified band is used.

Reference parameter for LTE cell size calculation:**Table F.2**

Parameter	
BS combiner loss	0 dB
UE antenna height	1,5 m
UE antenna gain	0 dB
UE sensitivity	According to 3GPP requirements for the tested band [9]
Downlink traffic type	Data
Uplink traffic type	Data

Annex G:
Void

Annex H (normative): Definition of load levels for dynamic test

The UEs shall be connected to each sector of the BS via power splitters and attenuators according to the method described in clause 6.4.2.1 and with the total path loss for the different UEs as defined in table H.1. The power levels for the pilot channels (CPICH for HSPA and RS for LTE) at the respective UE groups shall be as stated in table H.2.

Based on the path loss L defined in table H.1 the required pilot channel power can be calculated with formula H.1.

$$L_{UE,i} = P_{pilot\ channel,BS} - P_{pilot\ channel,UE,i} \quad (H.1)$$

Where:

- $L_{UE,i}$ the required total attenuation between the antenna connector of the BS and the UE group i ;
- $P_{pilot\ channel,BS}$ the power levels of the pilot channel transmitted at BS;
- $P_{pilot\ channel,UE,i}$ the power levels of the pilot channel received at the UE group i .

Table H.1: Total attenuation for different UE groups for different RAT

	Path loss for UE group 1 [dB]	Path loss for UE group 2 [dB]	Path loss for UE group 3 [dB]	Path loss for UE group 4 [dB]
WCDMA/HSPA	85	100	115	130
LTE	85	100	115	130

The pilot channel power allocation shall be made to achieve the following signal levels at each UE defined in table H.2.

Table H.2: Received pilot signal strength at different UE groups for different RAT

Technology	Control channel power	Received signal strength at UE group 1 [dBm]	Received signal strength at UE group 2 [dBm]	Received signal strength at UE group 3 [dBm]	Received signal strength at UE group 4 [dBm]
WCDMA/HSPA	CPICH = 33 dBm	-52	-67	-82	-97
LTE	RS = 15,2 dBm	-69,8	-84,8	-99,8	-114,8

The same path loss settings and received pilot signal strength shall be used for the test, independent of the total RF power of the base station in the wide area BS category defined in [2] and [12]. This will ensure that all capacity tests are carried out for the same cell size.

During the test, the UEs will receive data generated by IPERF or similar tool. The amount of data sent to each UE is defined according to clause 6.4.3 and is sent to each UE based on the equation (H2) for transmission timer $T_{t,UEi}$ and table H.4.

In LTE there is 1 UE in each UE group.

In WCDMA/HSPA there is 1 UE per carrier in each UE group.

A duty cycle includes the time for both activity level and the silence period. The total number of duty cycles during each test is $n = 10$.

There are three activity levels defined, 10 %, 40 % and 70 % corresponding to low, medium and busy hour traffic, see table H.3.

The activity levels are distributed over the time in a way that 10 % activity level is related to 6 hours a day, 40 % to 10 hours and 70 % to 8 hours. This distribution is weighted by factor c according to table H.3.

UDP (User Data Protocol) is used to generate data.

The tolerance factor TF is 0,25.

Table H.3: Time duration and weighting factor for duty cycle and different activity levels

	Low traffic (10 %)	Medium traffic (40 %)	Busy hour traffic (70 %)
T, activity time [s]	4	16	28
T_D, Duty cycle time [s]	40	40	40
n, number of duty cycles	10	10	10
Hours during a day [hours]	6	10	8
Weighting factor, c	0,25	0,42	0,33

T is activity time for generating data by IPERF or similar tool during each duty cycle. This time is in seconds.

T_D is the time for each duty cycle including both transmission and silence period.

M is the number of UE groups in each sector.

$T_{t,UEi}$ is the transmission time for data generated by IPERF or similar tool to different UE groups, see equation (H.2).

$T_{s,UEi}$ is the silence time when no data is transferred by IPERF or similar tool for each UE group during each duty cycle, see equation (H.3).

$$T_{t,UEi} = \frac{T}{M} \times i, \text{ for } i = 1, 2, \dots, M \quad (\text{H.2})$$

$$T_{s,UEi} = T_D - T_{t,UEi} \text{ for } i = 1, 2, \dots, M \quad (\text{H.3})$$

Table H.4: Transferring and silence time for each UE group for different activity levels

	Low traffic (10 %)		Medium traffic (40 %)		Busy hour traffic (70 %)	
	T_t [s]	T_s [s]	T_t [s]	T_s [s]	T_t [s]	T_s [s]
UE group 1	1	39	4	36	7	33
UE group 2	2	38	8	32	14	26
UE group 3	3	37	12	28	21	19
UE group 4	4	36	16	24	28	12

Figure H.1 shows the data traffic pattern for different UE groups with different transmission and silence time.

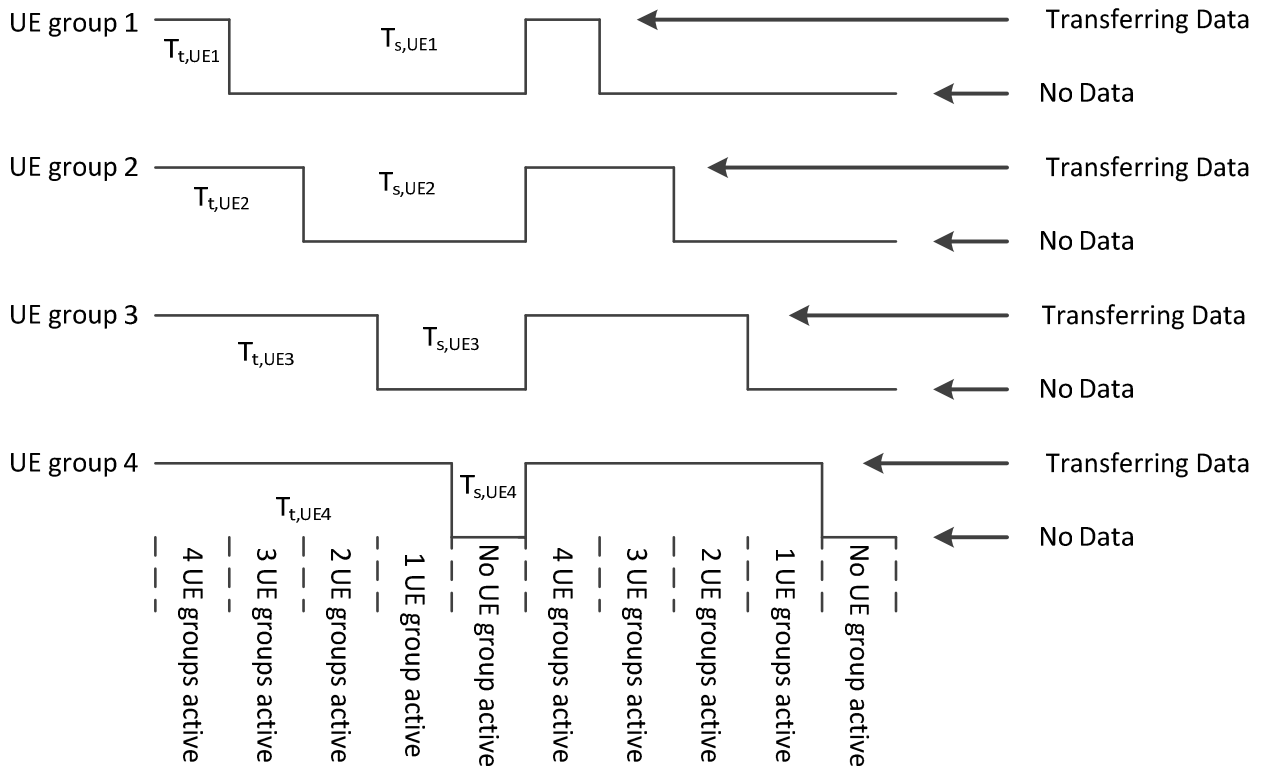

Figure H.1: Data traffic model for each UE group

Annex I (informative): Reference parameters for multi-standard (MCPA) system

To be developed in later version.

Annex J (normative): Uncertainty assessment

The wireless network efficiency data produced by the methods detailed in the present document will be subject to uncertainty due to the tolerance of measurement procedures or variance of real installations to the standard models suggested. The uncertainty of the measured parameters can be evaluated and will therefore provide comparable data, whilst that of the models used is subjective and should be assigned a sensitivity to assess significance.

J.1 General requirements

The assessment of uncertainty in the measurement of the static power consumption and dynamic efficiency of a base station shall be based on the general rules provided by the IEC/ISO Guide 98-3: 2008 [i.2] or equivalent GUM:2008 "JCGM 100:2008, Evaluation of measurement data - Guide to the expression of uncertainty in measurement" that is publicly available:

- http://www.bipm.org/utis/common/documents/jcgm/JCGM_100_2008_E.pdf.

Uncertainty factors are grouped into two categories according to the method used to estimate their numerical value:

- Type A: Those which are evaluated by statistical means.
- Type B: Those which are evaluated by other means, usually by scientific judgment using information available.

When a *Type A* analysis is performed, the standard uncertainty u_i shall be derived from the estimate from statistical observations.

When *Type B* analysis is performed, the standard uncertainty u_i is derived from the parameter $a = (a_+ - a_-)/2$, where a_+ is the upper limit and a_- is the lower limit of the measured quantity, and taking into account the distribution law of measured quantity, as follows:

- Normal law: $u_i = a/k$ where k is a coverage factor.
- U-shaped (asymmetric) law: $u_i = a/\sqrt{2}$.
- Rectangular law: $u_i = a/\sqrt{3}$ (default value to be used in the absence of any other information).
- Triangular law: $u_i = a/\sqrt{6}$ (not used in the present document).

J.2 Components contributing to uncertainty

The factors contributing to uncertainty are schematically shown in the uncertainty trees (figures J.1 and J.2).

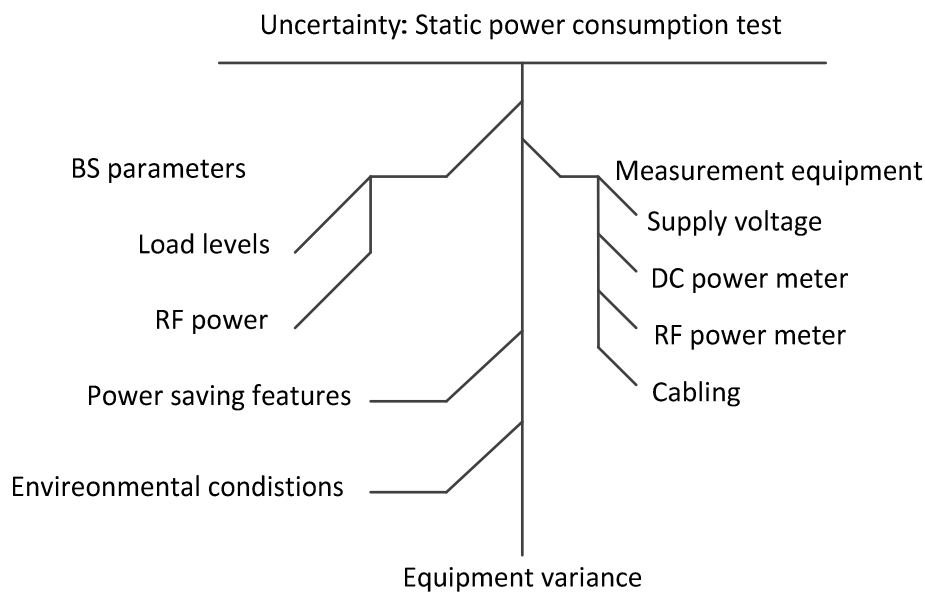

Figure J.1: Uncertainty tree - power consumption test

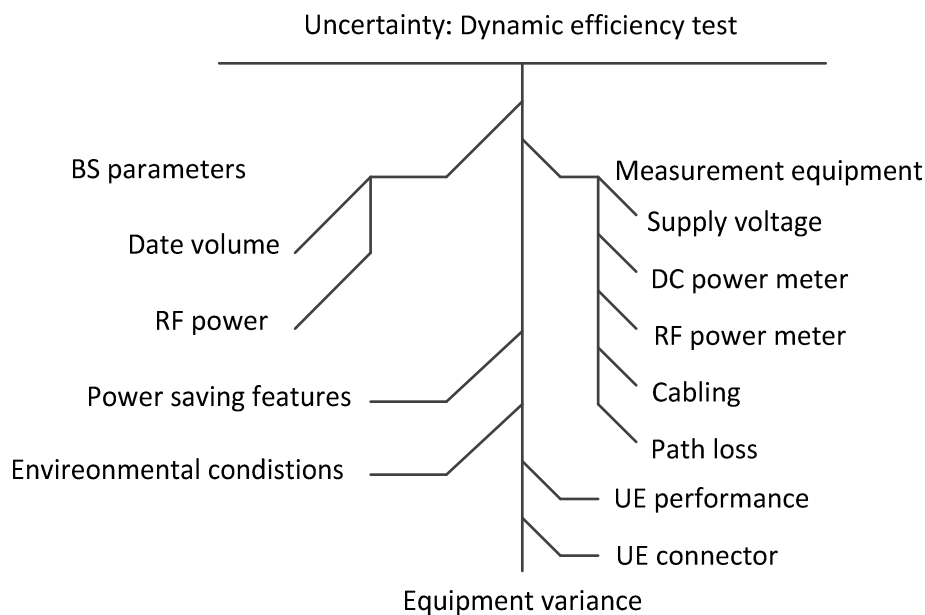

Figure J.2: Uncertainty tree - dynamic efficiency test

J.2.1 Contribution of the measurement system

J.2.1.1 Measurement equipment (static & dynamic)

The uncertainty contributed by the measurement equipment, e.g. voltmeter, power meter, RF power meter shall be assessed with reference to its calibration certificates. The uncertainty due to the measurement device shall be evaluated assuming a type B normal probability distribution.

J.2.1.2 Attenuators, cables (static and dynamic)

The uncertainty contributed by the attenuator, shall be assessed with reference to its calibration certificates. The uncertainty due to the attenuator shall be evaluated assuming a Type B normal probability distribution.

J.2.1.3 User equipment (UE) or UE emulator (dynamic)

Performance variances caused by drifts or performance of the UEs are controlled during the tests and the resulting error is less than $\pm x$ %. The uncertainty shall be evaluated assuming a Type B rectangular probability distribution.

The impact of connection of UEs (dynamic) is the uncertainty related to the lack of repeatability of the connection of the UEs. Other connectors are considered of sufficient stability and are therefore not considered.

The following process shall be used to assess the uncertainty due to connection issues:

- X (include a number) UEs using significantly different connector types shall be used for this test. Three people shall perform Y complete evaluations (including connection installation) of the energy efficiency using these X UEs. A statistical analysis shall be provided for each device at each position (i.e. at least 12 tests at each position for each device). The UE positioning uncertainty is the largest standard deviation determined by this evaluation.

The uncertainty due to the UE connection shall be evaluated assuming it has a Type B normal probability distribution.

J.2.2 Contribution of physical parameters

J.2.2.1 Impact of environmental parameters (static and dynamic)

The impact of environmental parameters (mainly temperature) is assessed taking into account temperature variation during the measurement period. It has to be assured that the DUT has reached stable conditions as defined in clause 5.2.3. The uncertainty shall be evaluated assuming a Type B rectangular probability distribution.

J.2.2.2 Impact of path loss(dynamic)

The contribution due to the path loss, radio effects, etc are controlled during the tests and the resulting error is less than $\pm x$ %. The uncertainty shall be evaluated assuming a Type B rectangular probability distribution. Path loss uncertainty is a result of attenuator and cable uncertainty as described under clause J.2.1.2.

J.2.2.3 Data volume (dynamic)

The uncertainty contributed by the traffic monitoring, shall be assessed with reference to its calibration certificates. The uncertainty due to the traffic monitoring shall be evaluated assuming a Type B normal probability distribution.

J.2.3 Variance of device under test

Based on component variances the individual base stations will have a certain deviations from the nominal value. The tested base station shall represent the nominal performance. The product to product efficiency spread is not considered in this uncertainty analysis but additional results on product efficiency spread might be provided.

J.3 Uncertainty assessment

J.3.1 Combined and expanded uncertainties

The contributions of each component of uncertainty shall be registered with their name, probability distribution, sensitivity coefficient and uncertainty value. The results shall be recorded in a table of the following form. The combined uncertainty shall then be evaluated according to the following formula:

$$u_c = \sqrt{\sum_{i=1}^m c_i^2 \cdot u_i^2} \quad (\text{J.1})$$

where c_i is the weighting coefficient.

The expanded uncertainty shall be evaluated using a confidence interval of 95 % using the templates defined in table J.1 for static measurements and table J.2 for dynamic measurements.

Table J.1: Uncertainty analysis for static power consumption assessment

ERROR SOURCES	Description (Subclause)	Uncertainty Value (%)	Probability Distribution	Divisor	c_i	Standard Uncertainty (%)
Measurement Equipment						
Supply voltage	J.2.1.1		Normal	1	1	
Power consumption / DC power meter	J.2.1.1		Normal	1	1	
RF power/RF power meter	J.2.1.1		Normal	1	1	
Cabling, Attenuators	J.2.1.2		Normal	1	1	
Physical Parameters						
Environment conditions (T)	J.2.2.1	5 %	Rectangular	$\sqrt{3}$	0,5	
BS parameters						
Equipment variance	J.2.3	-	Gaussian			
Combined standard uncertainty			$u_c = \sqrt{\sum_{i=1}^m c_i^2 \cdot u_i^2}$			
Expanded uncertainty (confidence interval of 95 %)			Normal			$u_e = 1,96 u_c$

Table J.2: Uncertainty analysis for dynamic efficiency assessment

ERROR SOURCES	Description (Subclause)	Uncertainty Value (%)	Probability Distribution	Divisor	c_i	Standard Uncertainty (%)
Measurement Equipment						
Supply voltage	J.2.1.1		Normal	1	1	
Power consumption / DC power meter	J.2.1.1		Normal	1	1	
RF power / RF power meter	J.2.1.1		Normal	1	1	
Cabling, Attenuators	J.2.1.2		Normal	1	1	
Data volume	J.2.1.3		Normal	1	1	
User equipment	J.2.1.3		Rectangular	$\sqrt{3}$	1	
Physical Parameters						
Environment conditions (T)	J.2.2.1	5 %	Rectangular	$\sqrt{3}$	0,5	
Impact of path loss	J.2.2.3		xx	xx	xx	
BS parameters						
Equipment variance	J.2.3	-	Gaussian			
Combined standard uncertainty			$u_c = \sqrt{\sum_{i=1}^m c_i^2 \cdot u_i^2}$			
Expanded uncertainty (confidence interval of 95 %)			Normal			$u_e = 1,96 u_c$

J.3.2 Cross correlation of uncertainty factors

Cross correlations of above uncertainty factors are not considered if not otherwise stated.

J.3.3 Maximum expanded uncertainty

The expanded uncertainty with a confidence interval of 95 % shall not exceed 10 % for static tests and 20 % for dynamic tests.

If the expanded uncertainty is exceeding this target, then the uncertainty shall be added to the measured results.

Annex K (informative): Reference parameters for WiMAX™ system

This annex describes reference configurations and load levels for WiMAX™ which were originally specified in version 1.2.1 of TS 102 706 [i.7].

The methodology for calculation energy efficiency as described in clause 7.2.7 applies.

NOTE: This annex has not been maintained and it might not reflect the most recent configurations.

Reference configurations for WiMAX™ system:

- Number of sectors and carriers: 3S3C (one different carrier per sector).
- Channel BW: 5,7 MHz or 10 MHz.
- RF output power level: 2x 35 dBm (MIMO configuration) or 4x 35 dBm (Beam forming configuration) per sector.
- Power Input: -48 V DC, 230 V AC.

WiMAX™ traffic model:

The sub-frame ratio has impact on the BS power consumption. For measurement the subframe ratio is 29:18 should be according to the specification IEEE 802.16e [13].

Table K.1: Traffic model for WiMAX™

	Low load	Medium load	Busy hour load
Load for S111 at 5 MHz	Three symbols dedicated to preamble, FCH, MAP should be transmitted at static power level.	Three symbols dedicated to preamble, FCH, MAP and 50 % DL date symbols should be transmitted at static power level.	Three symbols dedicated to preamble, FCH, MAP are active and 100 % DL date symbols should be transmitted at static power level.
Load for S111 at 7 MHz	Three symbols dedicated to preamble, FCH, MAP should be transmitted at static power level.	Three symbols dedicated to preamble, FCH, MAP and 50 % DL date symbols should be transmitted at static power level.	Three symbols dedicated to preamble, FCH, MAP are active and 100 % DL date symbols should be transmitted at static power level.
Load for S111 at 10 MHz	Three symbols dedicated to preamble, FCH, MAP should be transmitted at static power level.	Three symbols dedicated to preamble, FCH, MAP and 50 % DL date symbols should be transmitted at static power level.	Three symbols dedicated to preamble, FCH, MAP are active and 100 % DL date symbols should be transmitted at static power level.
Load level duration	6 hours	10 hours	8 hours

Frequency bands for WiMAX™:

The frequency band should be according to equipment specifications. For measurement centre frequency of the specified band is used.

Table K.2 gives examples of frequencies for bands defined in WiMAX™ Forum Mobile system profile:

- Table K.2 defines the RF channels to be calculated using the following formula:

$$RFChannel_n = F_{start} + n \cdot \Delta F_c, \forall n \in N_{range} \quad (K.1)$$

Where:

F_{start} is the start frequency for the specific band;

ΔF_c is the centre frequency step;

N_{range} is the range values for the n parameter.

Table K.2: Example of centre frequency definition for WiMAX™

RF Profile Name	Channel BW (MHz)	Centre Frequency Step (KHz)	F _{start} (MHz)	N _{range}	Comment
Prof1.B_2.3-5	5	250	2 302,5	{0 to 380}	
Prof1.B_2.3-10	10		2 305	{0 to 360}	
Prof2.B_2.305	5	250	2 307,5 and 2 347,5	{0 to 40}	
Prof2.C_2.305	10	250	2 310 and 2 350	{0 to 20}	
Prof3.A_2.496-5	5	250	2 498,5	{0 to 756}	200 KHz Frequency step is considered for Europe 2,5 GHz extension.
Prof3.A_2.496-10	10		2 501	{0 to 736}	
Prof5.A_3.4	5	250	3 402,5	{0 to 1 580}	
Prof5L.A_3.4				{0 to 780}	
Prof5H.A_3.4				{800 to 1 580}	
Prof5.B_3.4	7	250	3 403,5	{0 to 1 572}	
Prof5L.B_3.4				{0 to 772}	
Prof5H.B_3.4				{800 to 1 572}	
Prof5.C_3.4	10	250	3 405	{0 to 1 560}	
Prof5L.C_3.4				{0 to 760}	
Prof5H.C_3.4				{800 to 1 560}	

Annex L (informative): Derivation of formula for verification of minimum data delivered to UEs during dynamic test

This annex shows the derivation of formula mentioned in clause 7.2.4.

For better understanding the contents of this clause it is assumed that any group of UE is composed just by only one UE.

To not prioritize the cell centre UE with the best throughput compared with the cell border UE, it is required to have an equal distribution of the resources over the time for all active UE having available input data and this is to be checked by the following method.

The UE maximum throughput depends on the individual UE position in the cell (attenuation), as well on the number of UEs with active data to be scheduled.

Note that the measured UE maximum Throughput is not depending on the activation-level.

The measured maximum Throughput per UE:

The individual UE Throughput-maximum ($TP_{\max_{UE1}}$, ... $TP_{\max_{UE4}}$) is measured with different number of UEs with active data to be scheduled:

- $TP_{\max_{UE4}}$ is measured with UE4 alone in the cell.
- $TP_{\max_{UE3}}$ is measured when sharing the resources together with UE4.
- $TP_{\max_{UE2}}$ is measured when sharing the resources together with UE4 and UE3.
- $TP_{\max_{UE1}}$ is measured when sharing the resources together with UE4 and UE3 and UE2.

Annex H defines the scenarios of the appearance of the activity level per UE. Due to the fixed scenario there are 5 different phases, defined by the UEs, which receive their data during their activity levels:

The 5 phases, with active data of the UEs:

- Ph1: UE1, UE2, UE3, UE4
- Ph2: UE2, UE3, UE4
- Ph3: UE3, UE4
- Ph4: UE4
- Ph5: idle (no UE)

NOTE: The phases Ph1 to Ph4 are of the same duration (see annex H for definition of activity level).

The evaluated averaged Throughput per UE per transmission time:

Example for UE4:

$TP_{\max_{UE4}}$ is measured during Phase4, when UE4 is alone in the cell and gets all physical resources (LTE: PRB of PDSCH).

During Phase3, the UE4 has to share its resources with another UE, so there are 2 UEs in the cell:

$$TP_{Ph3,UE4} = 1/2 \times TP_{Ph4,UE4} = 1/2 \times TP_{\max_{UE4}} \quad (L.0)$$

Analogue for the other phases the throughput is estimated as following:

- 1) TP estimation of UE4 for its transmission time, $TP_{t,UE4}$:

$$TP_{Ph4,UE4} = TP_{maxUE4} \times 1/1 = TP_{maxUE4} \times 12/12$$

$$TP_{Ph3,UE4} = TP_{maxUE4} \times 1/2 = TP_{maxUE4} \times 6/12$$

$$TP_{Ph2,UE4} = TP_{maxUE4} \times 1/3 = TP_{maxUE4} \times 4/12$$

$$TP_{Ph1,UE4} = TP_{maxUE4} \times 1/4 = TP_{maxUE4} \times 3/12$$

$$\mathbf{TP_{t,UE4} = average of all phases = TP_{maxUE4} \times 25/12 / p_{UE4}}$$
- 2) TP estimation of UE3 for its transmission time, $TP_{t,UE3}$:

$$TP_{Ph3,UE3} = TP_{maxUE3} \times 1/1 = TP_{maxUE3} \times 12/12$$

$$TP_{Ph2,UE3} = TP_{maxUE3} \times 2/3 = TP_{maxUE3} \times 8/12$$

$$TP_{Ph1,UE3} = TP_{maxUE3} \times 2/4 = TP_{maxUE3} \times 6/12$$

$$\mathbf{TP_{t,UE3} = average of all phases = TP_{maxUE3} \times 26/12 / p_{UE3}}$$
- 3) TP estimation of UE2 for its transmission time, $TP_{t,UE2}$:

$$TP_{Ph2,UE2} = TP_{maxUE2} \times 1/1 = TP_{maxUE2} \times 12/12$$

$$TP_{Ph1,UE2} = TP_{maxUE2} \times 3/4 = TP_{maxUE2} \times 9/12$$

$$\mathbf{TP_{t,UE2} = average of all phases = TP_{maxUE2} \times 21/12 / p_{UE2}}$$
- 4) TP estimation of UE1 for its transmission time, $TP_{t,UE1}$:

$$TP_{Ph1,UE1} = TP_{maxUE1}$$

$$\mathbf{TP_{t,UE1} = average of all phases = TP_{maxUE1} / p_{UE1}}$$

General:

$$TP_{t,UEi} = TP_{maxUEi} \times SF_{UEi} / p_{UEi} \quad (\text{L.1})$$

Where:

- $TP_{t,UEi}$ is the averaged throughput during the active window of UE Group i;
- TP_{maxUEi} is the measured maximum Throughput per UE-Group i;
- SF_{UEi} is the Scenario dependent Factor per UE Group i, elaborated before (e.g. $SF_{UE4} = 25/12$);
- p_{UEi} is the number of different phases during the UE transmission time, equal to the UE group index:
 - $p_{UE1} = 1$; $p_{UE2} = 2$; $p_{UE3} = 3$; $p_{UE4} = 4$.

Finally, the sum of the received data per UE can be evaluated and compared with real received data:

- The real received data are those of the different Activation levels, but not yet weighted with the correction factor of the traffic model.
- The number of (correctly) received data per UE and per Activity Level, $\#Data_{x,UE1}$, ... $\#Data_{x,UE4}$:
 - This is the sum of (correctly) received data per UE of all duty cycles per activity-level.
- The phase duration is given by duty cycle time T_D , activity Factor AF_x and number of UE Groups M:
 - Phase duration = $T_D \times AF_x / M$.
- The number of phases per UE group = p_{UEi} . It is given by the UE group index.

- The #data have to be calculated on a Phase basis, multiplied with the number of phases.

A **tolerance factor TF** is introduced (see annex H), so the number of data (#Data) is allowed to be less than evaluated in the margin of example $TF = 25\%$.

Derivation of formula 6.b:

- $\#Data_{x,UEi} \geq TP \times t \times (1-TF)$
- $\#Data_{x,UEi} \geq TP_{t,UEi} \times n \times TD \times AF_x / M \times p_{UEi} \times (1-TF)$
- $\#Data_{x,UEi} \geq TP_{maxUEi} \times SF_{UEi} / p_{UEi} \times n \times TD \times AF_x / M \times p_{UEi} \times (1-TF)$
- $\#Data_{x,UEi} \geq TP_{maxUEi} \times SF_{UEi} \times n \times TD \times AF_x / M \times (1-TF)$
- $\#Data_{x,UEi} \geq TP_{maxUEi} \times SF_{UEi} \times n \times T_D \times AF_x / M \times (1-TF)$ (L.2)

Where:

- $\#Data_{x,UEi}$ is the tolerated, evaluated amount of data per UE-Group per Activation Level x;
- n is the number of duty cycles per activity level;
- T_D is the duty cycle duration;
- x is the Activity level;
- AF_x is the activityFactor per Activity level x;
- M is the number of UE Groups;
- TP_{maxUEi} is the measured maximum Throughput per UE-Group i;
- SF_{UEi} is the Scenario dependent Factor per UE-Group i, elaborated before (e.g. $SF_{UE4} = 25/12$);
- TF is the tolerance factor.

With current values (e.g. $SF_{UE4} = 25/12$; $SF_{UE3} = 26/12$; $SF_{UE2} = 21/12$; $SF_{UE1} = 12/12$; $n = 10$; $TD = 40$ s; $M = 4$; $TF = 0,25$), the number of data per UE per Activity Level is evaluated as:

- $\#Data_{x,UEi} \geq TP_{maxUEi} \times SF_{UEi} \times 10 \times 40 \text{ s} \times AF_x / 4 \times 75\%$
- $\#Data_{x,UE1} \geq TP_{maxUE1} \times 75 \text{ s} \times AF_x$
- $\#Data_{x,UE2} \geq TP_{maxUE2} \times 131,25 \text{ s} \times AF_x$
- $\#Data_{x,UE3} \geq TP_{maxUE3} \times 162,5 \text{ s} \times AF_x$
- $\#Data_{x,UE4} \geq TP_{maxUE4} \times 156,25 \text{ s} \times AF_x$

Note that here an example is computed and that the formula has to be used with actual parameter settings.

Annex M (informative): BS site efficiency parameters

This annex defines site reference parameters with impact on the efficiency of the BS at the site or represent additional power consumption at the site. The scope is to compare all BS types in an outdoor environment, considering AC power input to RF output power at the Antenna unit connector (i.e. not the "antenna connector" at BS).

Site parameters represent losses at BS site. Site Reference parameters represent typical losses for a typical BS site implementation corresponding to the BS structure and climate performance.

Site losses are:

- 1) RF losses in feeders and jumpers, L_{Bf} .
- 2) DC power losses in power distribution at site.
- 3) Energy consumption of site climate equipment.
- 4) Energy consumption of Backhaul and Fronthaul equipment, $P_{bh, fh}$.
- 5) Power losses in batteries and back-up system, P_{bbs} .
- 6) Energy Consumption of power system and back-up for tower warning light P_{twl} .

For 3), variations apply in field, but typical central European fallback values are proposed.

Fallback reference values for (5) and (6) are not proposed as variations at field are large.

Energy consumption (4) is included as BS "transmission interface" is included at BS power consumption testing.

(1): Typical values for concentrated and distributed BS are proposed.

(2): Typical values for DC power cable to remote units are proposed.

For site equipment that is not part of the product configuration, following reference parameter values are proposed:

- PSF, Power Supply Factor depending on power supply:
 - Equipment with AC power interface: PSF = 1,0.
 - Equipment with DC power interface: PSF = 1,1.
- CF, Cooling factor, to compensate for consumption and losses depending on type of cooling solution in order to scale different BS equipments for outdoor conditions.
 - Indoor BS equipment with fresh air fan based cooling solution: CF = 1,05 (for BS complying to +40 °C testing).
 - Indoor BS equipment with air condition controlled to 25 °C: CF = 1,5 (for BS complying to 25 °C testing but not +40 °C testing).
 - Outdoor RBS equipment: CF=1,0.
- PFF, power feeding factor for remote units to compensate for power losses of the DC feed cable to remote units of distributed base station:
 - Concentrated BS: PFF = 1,0.
 - Remote radio heads: PFF = 1,05.
- L_{Bf} , Feeder loss factor, including losses of feeder, jumpers and connectors (L_{Bf} is used in annex C for path loss and coverage area calculation):
 - Standard Macro BS site configuration: UL/DL loss is 3,0 dB.
 - For TMA configurations, the UL/DL jumper loss between antenna and TMA is 0,5 dB.
 - For Distributed BS with remote radio head at tower, UL/DL jumper loss is 0,5 dB.

Site losses impact on KPI's for typical site implementations.

- Site Energy Consumption, static test:
 - Distributed BS:

$$P_{c,site,static} = (P_{c,static} + P_{twl} + P_{bbs}) * PSF * CF \text{ [W]}$$

$$P_{RRH,site,static} = P_{RRH,static} * PSF * PFF \text{ [W]}$$
 - Concentrated BS:

$$P_{site,static} = (P_{equipment,static} + P_{twl} + P_{bbs}) * PSF * CF \text{ [W]}$$

- BS Site Energy Efficiency, dynamic testing:

Modify the Energy Efficiency formulas in dynamic part of document by replacing the equipment power consumption with site power consumption:

- Distributed BS:

$$P_{c,site,dyn} = (P_{c,dyn} + P_{twl} + P_{bbs}) * PSF * CF \text{ [W]}$$

$$P_{RRH,site,dyn} = P_{RRH,dyn} * PSF * PFF \text{ [W]}$$
- Concentrated BS:

$$P_{site,dyn} = (P_{equipment,dyn} + P_{twl} + P_{bbs}) * PSF * CF \text{ [W]}$$

Static coverage efficiency, site:

- $EE_{coverage,static,site} = coverage_area / P_{site,static} \text{ [km}^2\text{/kW]}$

Annex N (informative): Example assessment

This annex presents results of a fictive assessment for 900 MHz GSM system. The system reference parameters are listed in table N.1 and results in tables N.2 and N.3.

Table N.1: Reference parameters of fictive 900 MHz GSM BS

Parameter	Value	Unit
1) BS configuration		
1.1) Number of sectors	3	
1.2) Nominal max RF output power per sector	40	W
1.3) Number of Carriers or TRXs per sector		
1.3.1) Number of carriers the BS is able to support	4	
1.3.2) Number of carriers, for which the HW was enabled (independent whether or not the carriers were used for the test)	3 x 2	
1.3.3) Number of carriers used during the test	2	
1.4) TX diversity	Cross polar antenna	
1.5) RX diversity	Two way diversity	
1.6) Type of RF signal combining	Air combining with cross polar antenna	
2) Frequency		
2.1) Downlink band	925 to 960	MHz
2.2) Uplink band	880 to 915	MHz
2.3) Channel bandwidth	0,20	MHz
3) Environment		
3.1) Temperature range	-33 to +40	°C
3.2) Type of air filter	NA	
4) Features		
4.1) Power saving features	None	
4.2) Coverage and capacity features	None	
4.3) Downlink ciphering used? (Y/N)		

Table N.2: Measurements conditions and results of fictive 900 MHz GSM BS

Parameter	Test case 25 °C	Test case 40 °C	Unit
1) Test environment			
1.1) Temperature during test (measured)	25,3	40,2	°C
1.2) Pressure (measured)	102,5	102,6	kPa
1.3) Relative humidity (measured ¹)	41 %	46 %	
2) Downlink frequency used at test			
2.1) Centre frequency of low end channel	925,1	925,1	MHz
2.2) Centre frequency of middle channel	942,5	942,5	MHz
2.3) Centre frequency of high end channel	959,9	959,9	MHz
2.4) Uplink center frequency of middle channel	897,5	897,5	MHz
3) Supply voltage			
3.1) DC voltage (measured)	54,0	54,0	V
3.2) AC voltage (measured, phase to neutral)	NA	NA	V
3.3) AC Frequency (measured)	NA	NA	Hz
4) Power consumption (measured)			
4.1) Busy hour load, Middle frequency channel	819	840	W
4.2) Medium load, Middle frequency channel	681	698	W
4.3) Low load			
4.3.1) Low end frequency channel	642	663	W
4.3.2) Middle frequency channel	640	661	W
4.3.3) High end frequency channel	644	665	W
4.3.4) Average consumption with low load	642	663	W
5) TX output power (pilot signal only)			
5.1) Output power at low end channel	41,7	41,7	W
5.2) Output power at middle end channel	41,8	41,8	W
5.3) Output power at high end channel	41,6	41,6	W
5.4) Average output power per sector	41,7	41,7	W
6) RX receiver sensitivity at middle channel	-113,0	-113,0	dBm
7) Expanded uncertainty	17	17	%

Table N.3: Assessment results for fictive 900 MHz GSM BS

Parameter	Value	Unit
1) $P_{\text{equipment}}$ of integrated BS power consumption at 25 °C	717	W
2) $P_{\text{equipment}}$ of integrated BS power consumption at 40 °C	737	W
3) $P_{\text{equipment}}$ of distributed BS power consumption at 25 °C	717	W
3.1) $P_{\text{equipment}}$ of distributed BS power consumption at 25 °C for central part	207	W
3.2) $P_{\text{equipment}}$ of distributed BS power consumption at 25 °C for remote part	510	W
4) $P_{\text{equipment}}$ of distributed BS power consumption at 40 °C	737	W
4.1) $P_{\text{equipment}}$ of distributed BS power consumption at 40 °C for central part	210	W
4.2) $P_{\text{equipment}}$ of distributed BS power consumption at 40 °C for remote part	527	W

Annex O (informative): Bibliography

- NIST Technical Note 1297: "Guidance for evaluating and expressing the uncertainty of NIST measurement results".

History

Document history		
V1.1.1	August 2009	Publication as TS 102 706
V1.2.1	October 2011	Publication as TS 102 706
V1.3.1	July 2013	Publication as TS 102 706
V1.4.0	October 2014	Membership Approval Procedure MV 20141212: 2014-10-13 to 2014-12-12