

ETSI ES 201 970 V1.1.1 (2002-05)

ETSI Standard

**Access and Terminals (AT);
Public Switched Telephone Network (PSTN);
Harmonized specification of physical and electrical
characteristics at a 2-wire analogue presented
Network Termination Point (NTP)**



Reference

DES/AT-010101

Keywords

interface, PSTN

ETSI

650 Route des Lucioles
F-06921 Sophia Antipolis Cedex - FRANCE

Tel.: +33 4 92 94 42 00 Fax: +33 4 93 65 47 16

Siret N° 348 623 562 00017 - NAF 742 C
Association à but non lucratif enregistrée à la
Sous-Préfecture de Grasse (06) N° 7803/88

Important notice

Individual copies of the present document can be downloaded from:

<http://www.etsi.org>

The present document may be made available in more than one electronic version or in print. In any case of existing or perceived difference in contents between such versions, the reference version is the Portable Document Format (PDF). In case of dispute, the reference shall be the printing on ETSI printers of the PDF version kept on a specific network drive within ETSI Secretariat.

Users of the present document should be aware that the document may be subject to revision or change of status. Information on the current status of this and other ETSI documents is available at

<http://portal.etsi.org/tb/status/status.asp>

If you find errors in the present document, send your comment to:

editor@etsi.fr

Copyright Notification

No part may be reproduced except as authorized by written permission.
The copyright and the foregoing restriction extend to reproduction in all media.

© European Telecommunications Standards Institute 2002.
All rights reserved.

DECTTM, **PLUGTESTS**TM and **UMTS**TM are Trade Marks of ETSI registered for the benefit of its Members.
TIPHONTM and the **TIPHON logo** are Trade Marks currently being registered by ETSI for the benefit of its Members.
3GPPTM is a Trade Mark of ETSI registered for the benefit of its Members and of the 3GPP Organizational Partners.

Contents

Intellectual Property Rights	5
Foreword.....	5
Introduction	5
1 Scope	6
2 References	6
3 Definitions, symbols and abbreviations	8
3.1 Definitions	8
3.2 Symbols.....	8
3.3 Abbreviations	9
4 General	9
5 Physical connections	10
5.1 Mechanical Aspects.....	10
5.2 Support of more than one terminal	10
5.2.1 Wiring arrangement	10
5.2.2 Loading Factors	10
6 DC feed conditions.....	11
6.1 Polarity	11
6.2 Quiescent state.....	11
6.2.1 Maximum voltage.....	11
6.2.2 Minimum voltage.....	11
6.2.3 Supply interruption	11
6.3 Loop current	11
6.3.1 Loop current range.....	11
6.3.2 Loop current interruptions caused by the terminal	12
7 Seize signal.....	12
7.1 Must not seize condition.....	12
7.2 Must seize condition.....	12
8 Clear signal.....	12
8.1 Clear signal generated by TE	12
8.2 Clear indication from the network.....	13
8.3 Seizing the line for a new call	13
9 Impedance	13
9.1 NTP impedance	13
9.2 Balance about earth	14
10 Transmission	14
10.1 Relative level.....	14
10.2 Frequency response	15
10.3 Coding law	15
10.4 Noise	15
10.5 Maximum input levels.....	16
10.6 Stability	16
10.7 Crosstalk.....	16
11 DTMF Dialling.....	16
12 Ringing	17
12.1 Ringing drive capability	17
12.1.1 Ringing frequency	17
12.1.2 Ringing voltage.....	17
12.1.2.1 Ringing with DC	17

12.1.2.2	Ringing without DC	17
12.2	Ring cadence	18
12.3	Ring trip	19
12.4	False ring trip	19
13	Supervisory signals	19
13.1	Supervisory tones	19
13.2	Tone levels	19
13.3	Cadences and frequencies.....	20
14	Optional functions	20
14.1	Loop Disconnect dialling	20
14.2	Register recall.....	20
14.3	Metering	21
14.4	ALASS and other enhanced services.....	21
14.5	Polarity reversal.....	21
14.6	End of call signal ("K-break").....	21
14.7	Payphones.....	22
Annex A (informative):	Bibliography.....	23
History		24

Intellectual Property Rights

IPRs essential or potentially essential to the present document may have been declared to ETSI. The information pertaining to these essential IPRs, if any, is publicly available for **ETSI members and non-members**, and can be found in ETSI SR 000 314: "*Intellectual Property Rights (IPRs); Essential, or potentially Essential, IPRs notified to ETSI in respect of ETSI standards*", which is available from the ETSI Secretariat. Latest updates are available on the ETSI Web server (<http://webapp.etsi.org/IPR/home.asp>).

Pursuant to the ETSI IPR Policy, no investigation, including IPR searches, has been carried out by ETSI. No guarantee can be given as to the existence of other IPRs not referenced in ETSI SR 000 314 (or the updates on the ETSI Web server) which are, or may be, or may become, essential to the present document.

Foreword

This ETSI Standard (ES) has been produced by ETSI Technical Committee Access and Terminals (AT), and is now submitted for the ETSI standards Membership Approval Procedure.

Introduction

The present process of harmonization of the 2-wire analogue voice band switched interface (traditionally PSTN) has focussed on harmonization of the terminal equipment. Now that the terminal harmonization process is nearing completion, it becomes feasible to move towards harmonization of the network termination point (NTP) itself. This is particularly true for new local access delivery systems which tend to provide service via short local loops.

NOTE: In this last case the performance of the NTP is basically identical to the performance of the network equipment that delivers the NTP.

It is not suggested that installed networks be upgraded to meet the proposed specification since this would clearly be uneconomic. Existing operators may, however, consider that there are benefits in evolving their NTPs towards a common specification as network elements are replaced.

1 Scope

The present document is applicable to an analogue presented Network Termination Point (NTP) intended to deliver 3,1 kHz voiceband services which terminates a Public Switched Telephone Network (PSTN) with short to medium length 2-wire local loops, or equivalent NTPs, independently of the technologies used in the access part of the network itself. For the purpose of the present document, a "short to medium length 2-wire local loop" has a loop resistance not greater than 750 Ω .

NOTE 1: The local loop might use Fixed Wireless Access, xDSL or other technologies. The network itself might also be of different types. There may be a need for filtering in case of non-desirable connections (signal transfer) between these technologies and the NTP specified in the present document.

The present document applies to NTPs where any terminal equipment (TE) connected to NTP is connected via a cable with a maximum loop resistance of 100 Ω .

NOTE 2: This is equivalent to approximately 500 metres of cable with 0,5 mm diameter copper conductors.

The objective of the present document is to specify the physical and electrical characteristics at an analogue NTP particularly suitable for use for new network deployment; operators of existing PSTNs are not expected to modify their network to align with the present document. The present document specifies characteristics of the NTP to enable it to operate with most existing national PSTN TE, and especially with PSTN TE designed according to the European standards for analogue presented TEs.

The electrical conditions specified at the NTP are sufficient to ensure satisfactory operation of the following functions of TE:

- a) call control;
- b) transmission;
- c) dialling;
- d) ringing.

The present document does not specify the design characteristics of an equipment that delivers the NTP.

NOTE 3: However, where the line length between the NTP and the equipment that delivers the NTP is very short, the requirements of the present document becomes de-facto design requirements for the line card of the equipment that delivers the NTP. See figure 1 for clarity.

2 References

The following documents contain provisions which, through reference in this text, constitute provisions of the present document.

- References are either specific (identified by date of publication and/or edition number or version number) or non-specific.
- For a specific reference, subsequent revisions do not apply.
- For a non-specific reference, the latest version applies.

[1] ETSI TBR 021: "Terminal Equipment (TE); Attachment requirements for pan-European approval for connection to the analogue Public Switched Telephone Networks (PSTNs) of TE (excluding TE supporting the voice telephony service) in which network addressing, if provided, is by means of Dual Tone Multi Frequency (DTMF) signalling".

[2] ETSI TR 101 768: "Public Switched Telephone Network (PSTN); Study on the generation of analogue ringing signals".

- [3] ETSI TBR 038: "Public Switched Telephone Network (PSTN); Attachment requirements for a terminal equipment incorporating an analogue handset function capable of supporting the justified case service when connected to the analogue interface of the PSTN in Europe".
- [4] ETSI EN 300 659-1: "Access and Terminals (AT); Analogue access to the Public Switched Telephone Network (PSTN); Subscriber line protocol over the local loop for display (and related) services; Part 1: On-hook data transmission".
- [5] ETSI EN 300 659-2: "Access and Terminals (AT); Analogue access to the Public Switched Telephone Network (PSTN); Subscriber line protocol over the local loop for display (and related) services; Part 2: Off-hook data transmission".
- [6] ETSI EN 300 659-3: "Access and Terminals (AT); Analogue access to the Public Switched Telephone Network (PSTN); Subscriber line protocol over the local loop for display (and related) services; Part 3: Data link message and parameter codings".
- [7] ITU-T Recommendation G.711 (1988): "Pulse code modulation (PCM) of voice frequencies".
- [8] ETSI TR 101 183: "Public Switched Telephone Network (PSTN); Analogue ringing signals".
- [9] ITU-T Recommendation G.100.1 (2001): "The use of the decibel and of relative levels in speechband telecommunication".
- [10] ETSI ES 201 235-1: "Specification of Dual Tone Multi-Frequency (DTMF) Transmitters and Receivers; Part 1: General".
- [11] ETSI ES 201 235-3: "Access and Terminals (AT); Specification of Dual-Tone Multi-Frequency (DTMF) Transmitters and Receivers; Part 3: Receivers".
- [12] ETSI ES 201 729: "Public Switched Telephone Network (PSTN); 2-wire analogue voice band switched interfaces; Timed break recall (register recall); Specific requirements for terminals".
- [13] ITU-T Recommendation Q.35 /E.180 (1998): "Technical characteristics of tones for the telephone service".
- [14] ETSI TR 101 041-1: "Human Factors (HF); European harmonization of network generated tones; Part 1: A review and recommendations".
- [15] ETSI ETR 344: "Terminal Equipment (TE); The technical feasibility of a harmonized plug and socket standard for European Public Switched Telephone Network (PSTN) access".
- [16] ETSI ES 201 187: "2-wire analogue voice band interfaces; Loop Disconnect (LD) dialling specific requirements".
- [17] ETSI EG 201 120: "Public Switched Telephone Network (PSTN); Method of rating terminal equipment so that it can be connected in series and/or in parallel to a Network Termination Point (NTP)".
- [18] ITU-T Recommendation Q.552 (2001): "Transmission characteristics at 2-wire analogue interfaces of digital exchange".
- [19] ITU-T Recommendation G.117 (1996): "Transmission aspects of unbalance about earth".
- [20] ITU-T Recommendation G.120 (1998): "Transmission characteristics of national networks".
- [21] ITU-T Recommendation V.92 (2000): "Enhancements to Recommendation V.90".
- [22] ETSI TR 101 182: "Analogue Terminals and Access (ATA); Definitions, abbreviations and symbols".
- [23] FCC 47: "Federal Communications Commission" (Title 47 of the Code of Federal Regulations (CFR): CFR 68.500".
- [24] ETSI ES 201 912: "Access and Terminals (AT); Short Message Service (SMS) for PSTN/ISDN; Short Message Communication between a fixed network Short Message Terminal Equipment and a Short Message Service Centre".

[25] ETSI ES 201 071: "Public Switched Telephone Network (PSTN); Protocol over the local loop for display services; Server Display and Script Services (SDSS)".

3 Definitions, symbols and abbreviations

3.1 Definitions

For the purposes of the present document, the following terms and definitions apply:

answer signal: indication that a terminal is answering an incoming call

called party answer signal: signal which may be provided at the call originating NTP by the network to indicate that the called party has answered the call

clear indication: indication that the network is attempting to release a connection

clear signal: signal indicating that a terminal is attempting to release a connection

end-of-call signal: signal provided at the NTP by the network to indicate that the call has been released

longitudinal conversion loss: measure of the degree of unbalance about earth. More information is given in ITU-T Recommendation G.117, clause 4.1.3

Network Termination Point (NTP): physical point at the boundary of the PSTN intended to accept the connection of a TE (see figure 1 of ES 201 970)

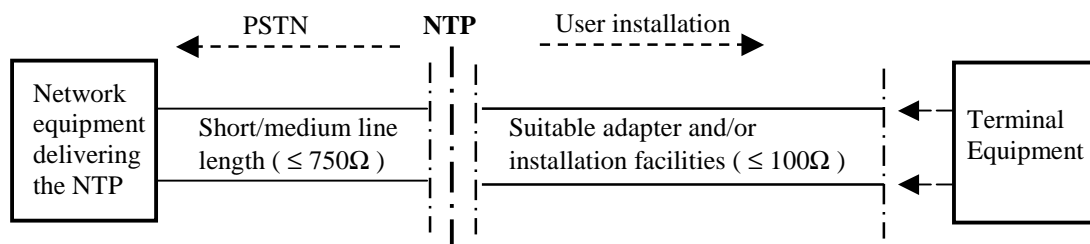

Figure 1: Network Termination Point (NTP)

ringing state: condition of the network where a ringing/alerting signal has been applied at the NTP

ring trip: removal of the ringing signal at the NTP in response to a valid answer signal applied to the NTP

seize signal: signal indicating that a terminal is attempting to establish a connection by means of applying a loop condition

3.2 Symbols

For the purposes of the present document, the following symbols apply:

dBV	the absolute voltage level expressed as dB relative to 1 V
dBm ₀	the absolute power level in dBm referred to a point of zero relative level (dBm is the absolute power level expressed as dB relative to 1 mVA)
dBr	the relative level of a signal in a transmission path referred to the level at a reference point on the path

NOTE: For more information on dB-related issues, see ITU-T Recommendation G.100.1 [9].

3.3 Abbreviations

For the purposes of the present document, the following abbreviations apply:

AC	Alternating Current
AGC	Automatic Gain Control
ALASS	Analogue Local Access Signalling Services
DC	Direct Current
DTMF	Dual Tone Multi Frequency
IDP	Inter-Digital Pause
LD	Loop Disconnect
LF	Loading Factor
LU	Loading Unit
NTP	Network Termination Point
PCM	Pulse Code Modulation
PSTN	Public Switched Telephone Network
RLR	Receiving Loudness Rating
SLR	Sending Loudness Rating
TE	Terminal Equipment
xDSL	x (A, H, V, lite...) Digital Subscriber Line

4 General

The operator shall describe any functions that are provided at the NTP such as protection, line test or filtering to support other services such as private metering or xDSL, insofar as these influence the behaviour at the NTP.

The performance at the NTP is intended to ensure that:

- the interface presented by the NTP will interwork successfully with TE compliant with PSTN TE TBRs (TBR 021 [1]) and will support voice band services accessible across the interface (TBR 038 [3]);
- the network being presented at the NTP will not suffer harm as a result of signals normally appearing at such an interface, when used under normal operating conditions, including when TE compliant with PSTN TBRs (TBR 021 [1] and TBR 038 [3]) are connected via the NTP.

The following states and conditions described in TR 101 182 [22] are considered in the present document.

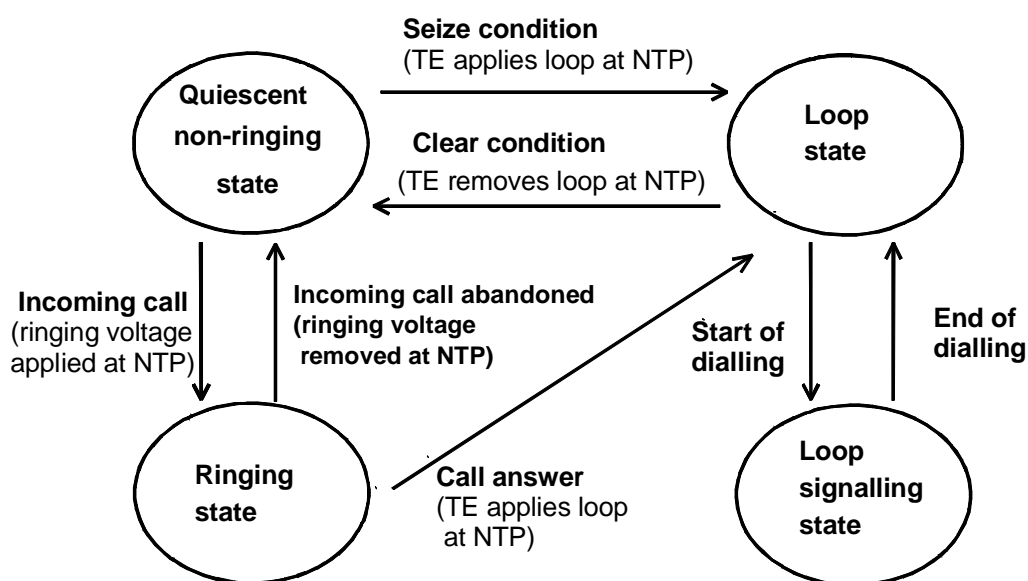

Figure 2: States and conditions

5 Physical connections

5.1 Mechanical Aspects

The physical presentation shall be specified in such a way that a terminal manufacturer can supply a suitable terminal connector. The connection arrangements should:

Option 1) either be according to established national practice;

Option 2) or by the arrangement described below.

Recommended harmonized arrangement:

Where the NTP is presented as a socket it should be a socket capable of connecting with a miniature 6-position plug as specified in FCC 47, (CFR 68.500) [23], clause (a) with contact assignments as specified in table 1. This connector is often referred to as RJ 11/12.

Table 1: Contact assignments

Contact number	Pin allocation
1	Unspecified
2	Unspecified
3/4	Pair (A- and B-wire)
5	Unspecified
6	Unspecified

NOTE 1: A selection of national arrangements are described in ETR 344 [15].

NOTE 2: In some cases the NTP is located outside of the user premises in which case the physical presentation may be realized as a set of connection contacts (e.g. a screw terminal block).

5.2 Support of more than one terminal

5.2.1 Wiring arrangement

The operator shall inform his customers of wiring arrangements for the connection of additional terminals. The instructions shall be expressed in a way that makes it straightforward for a customer to add additional points for connection of terminals.

5.2.2 Loading Factors

The operator should inform the users about the maximum numbers of terminals that can be supported at the NTP. This information should be supplied in terms of a Loading Factor (LF), as defined in EG 201 120 [17], for the parameters given in table 2.

The LF specified by the operator should be the lowest of the LFs for the individual TE parameters of table 2, rounded down to the nearest whole number.

The NTP should be able to operate with an LF of at least 100 LU.

NOTE: In addition to the LF-value discussed above, the operator is invited to also give the applicable LF-values of each individual parameter. This more detailed information would enable a skilled user to take full advantage of the available resources at the NTP.

Table 2: Calculation of loading factors

Operating state of TE	Terminal Parameter	Test method	Value for 100 LU	Formula for calculation of LF and unit for input data
Quiescent	Resistance to earth	TBR 021 [1], A.4.4.4	$R = 10 \text{ M}\Omega$	$1\ 000/R \text{ [M}\Omega\text{]}$
Quiescent	DC resistance	TBR 021 [1], A.4.4.1	$R = 1 \text{ M}\Omega$	$100/R \text{ [M}\Omega\text{]}$
Ringling	Impedance at 25 Hz	TBR 021 [1], A.4.4.2.1	$Z = 4 \text{ k}\Omega$	$400/Z \text{ [k}\Omega\text{]}$
Ringling	DC current during ringling	TBR 021 [1], A.4.4.2.3	$I = 0,6 \text{ mA}$	$100 \times I / 0,6 \text{ [mA]}$

6 DC feed conditions

6.1 Polarity

The polarity of the DC voltage presented at the NTP is arbitrary with respect to the NTP terminals.

6.2 Quiescent state

6.2.1 Maximum voltage

The maximum open circuit DC voltage presented between the A- and B- wires of the NTP shall not exceed 78 V.

6.2.2 Minimum voltage

When a resistor with a value of $100/LF \text{ M}\Omega$, where LF is the stated LF arising from clause 5.2.2, is connected between the A- and B- wires of the NTP, the continuous DC voltage appearing at the NTP shall not be less than 38 V.

NOTE: The requirement assumes that individual LF-values are given as suggested by the note in clause 5.2.2 and that the LF is taken from table 2, "DC resistance in quiescent state".

6.2.3 Supply interruption

Many types of terminal equipment rely on the continuous application of exchange battery voltage for the correct functioning of features.

It is recommended that during the quiescent state the network feed voltage applied at the NTP should not be removed for periods longer than 10 s for maintenance or other purposes.

6.3 Loop current

6.3.1 Loop current range

When a resistor with a value in the range 0Ω to 500Ω is connected between the A- and B- wires at the NTP, a minimum DC current of 18 mA shall flow but shall not exceed 70 mA. It is recommended that the DC current be in the range of 25 mA to 40 mA.

NOTE 1: 18 mA is the minimum current required to match the TE access requirements for interworking with the network.

NOTE 2: The minimum current takes into account the resistance of the internal wiring between NTP and the sockets for TE connections, and possible series TEs.

6.3.2 Loop current interruptions caused by the terminal

Brief loop current interruptions (where the current becomes less than 1,0 mA) of up to 20 ms between the A- and B- wires shall not cause any change of condition at the NTP.

7 Seize signal

7.1 Must not seize condition

When a resistor with a value such as to cause a loop current not greater than 3,0 mA DC to flow is connected at the A- and B- wires of the NTP, it shall not be recognized by the network as a seize signal.

The network shall not recognize a seize condition when the loop current changes from quiescent state to loop state levels for a period of less than a value stated by the operator. This value shall not be less than 10 ms.

7.2 Must seize condition

When a resistor with a value such as to cause a loop current equal to or greater than 10,0 mA DC to flow is connected for a period of greater than a value stated by the operator at the A- and B- wires of the NTP, it shall be correctly accepted by the network as a seize signal. The stated value shall not be higher than 150 ms.

NOTE: Some designs of line interface, particularly those with constant current feed, use a high impedance monitoring facility with a reduced current drive capability to check for a seize condition before applying the normal loop current drive capability. For example, 50 V may be applied via a 10 k resistor (i.e. a maximum current of 5 mA) with a seize-current threshold of 4 mA. Similarly, some designs of terminal equipment, particularly line powered TE using solid state hookswitches, may assume the instant availability of a minimum loop current of say 18 mA. Such designs of terminal may not achieve the loop state condition if only 5 mA is available due to insufficient current to fully operate the electronic hookswitch. While in this partial loop state condition, TE may present an equivalent resistance up to 5 k instead of the normal loop state condition. Care needs to be taken to ensure that proper startup occurs when such terminals and line interfaces are inter-working. This may best be achieved by meeting the following additional transient seize condition: It is recommended that during the transition from quiescent state to loop state, the NTP should be capable of supplying a minimum current of 4 mA into a load of 5 k Ω for a minimum period of 20 ms. This implies that for TE to correctly seize network interfaces providing a partial loop current, they should be developed so as to present an equivalent resistance not exceeding 5 k Ω with a loop current of 4 mA.

8 Clear signal

8.1 Clear signal generated by TE

In order to ensure satisfactory operation of the seize/clear function, hysteresis of the seize and clear currents shall be provided. The clear signal threshold current shall be at least 0,5 mA lower than the seize signal threshold current.

When the load applied at the A- and B- wires of the NTP is such as to reduce the loop current below the clear threshold current for a period:

- a) less than 250 ms, the network shall not accept this as a clear signal; and
- b) greater than 500 ms, the network shall accept this as a clear signal and release the loop condition at the NTP.

These time period values are valid for the calling party. For the called party, other values are possible (usually much longer times, e.g. to allow for the called party to change from one TE to another), and shall be stated by the operator.

8.2 Clear indication from the network

Depending upon the network characteristics, a connection may be cleared:

- a) as a result of calling party TE providing a clear signal to the network; or
- b) as a result of either the calling party or the called party TE providing a clear signal to the network; or
- c) at the instigation of the network itself, independently of the state of the calling party or the called party.

A PSTN end-of-call signal shall be applied at the NTP when the connection is cleared. This should be given as a release tone as specified in clause 13.3.

NOTE: In case other end-of-call signals are used in addition to the release tone, e.g. polarity reversal (see clause 14.5) or K-break (see clause 14.6), it needs to be specified by the operator.

8.3 Seizing the line for a new call

After the network has recognized the call clear signal from the TE, the NTP shall allow the TE to seize the line for a new call according to clause 7. In particular, an event indicating that a new seizure condition has been applied by the TE shall not be ignored whenever it occurs following recognition by the network of a call clear signal.

NOTE: This applies to both cases (clearing from calling and called party) mentioned in clause 8.1.

9 Impedance

9.1 NTP impedance

The impedance presented by the network between the A- and B- wires of the NTP when in the loop state shall have a return loss not less than the values shown in table 3 (linear dB - logarithmic frequency scale) with respect to the reference impedance Z_r shown in figure 3. This requirement shall be met for any DC current that can be delivered at the NTP (i.e. between the 18 mA and the short circuit current).

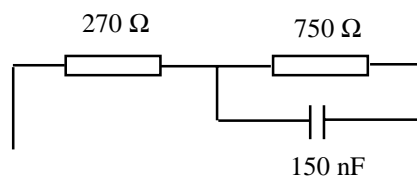

Figure 3: Reference impedance Z_r

Table 3: Return loss requirements

Frequency [Hz]	Requirement [dB]
200 - 300	8
300 - 500	8 - 10
500 - 1 250	10 - 14
1 250 - 3 400	14
3 400 - 3 800	14 - 12

NOTE 1: Where the line length between the NTP and the interface card of the network terminating unit is very short, it is assumed that return loss values are close to those specified for the interface card itself. It is advised that the design of the line card follows relevant ITU-T Recommendations, in particular Recommendation Q.552 [18]. It should be noted that the frequency range has been extended to accommodate voice band data applications.

NOTE 2: Values in table 3 at low to medium frequencies may not be achieved where the loop resistance between the NTP and the interface card of the terminating unit is greater than 750 Ω .

9.2 Balance about earth

The balance about earth at the NTP, measured as Longitudinal Conversion Loss, shall not be less than the values given in table 4 (the higher value applies at the transition frequency):

Table 4: Balance about earth requirements

Frequency [Hz]	Requirement [dB]
50	40
200 - 600	40
600 - 3 800	46

NOTE 1: It is recognized that this requirement may be difficult to measure at the NTP. It should be interpreted as a design target for the equipment delivering the NTP (where it can be more easily measured), and also in the choice of cable (the copper pairs of the cable should have a sufficiently high balance).

NOTE 2: These values are taken from ITU-T Recommendation Q.552 [18], except that the frequency range has been extended to accommodate voice band data applications.

10 Transmission

NOTE 1: The transmission performance aspects are given at the NTP, not at the output/input of the equipment delivering the NTP. It is however advised that the design of such interface cards is based on ITU-T Recommendation Q.552 [18]. Interfaces complying with ITU-T Recommendation Q.552 [18] will meet the requirements of this clause (note that ITU-T Recommendation Q.552 [18] does not specify the exact value of relative levels).

NOTE 2: Due to the fact that this is a specification of the NTP and not a specification of the equipment delivering the NTP, only one observation point is available. Thus in principle it is not possible to state performance between two points. However, fictitious points in the transmit- and receive digital path (A-law PCM, 0 dBr, see figure 4) are established for reference purposes.

10.1 Relative level

To enable full signal handling capacity, the nominal relative levels (at 1 020 Hz) at the NTP shall be:

Input relative level $L_i = +4 \pm 2$ dBr;

Output relative level $L_o = -11 \pm 2$ dBr.

NOTE 1: The concept of relative levels is described in ITU-T Recommendation G.100.1 [9].

NOTE 2: These relative levels are chosen to obtain optimum performance for a speech telephony terminal in accordance with TBR 038 [3] having nominal SLR = +3 dB and RLR = -8 dB.

NOTE 3: Deviations in relative levels are caused by statistical line distributions (attenuations).

NOTE 4: Some types of line interfaces which provide constant DC current feeding will prevent the Automatic Gain Control (AGC) function of existing TEs from operating. Therefore it is recommended that such line cards provide an AGC function in order to provide acceptable performance especially on short line lengths.

The relative level is assumed to be 0 dBr on the digital side of the analogue/digital conversion point in the local network. See figure 4.

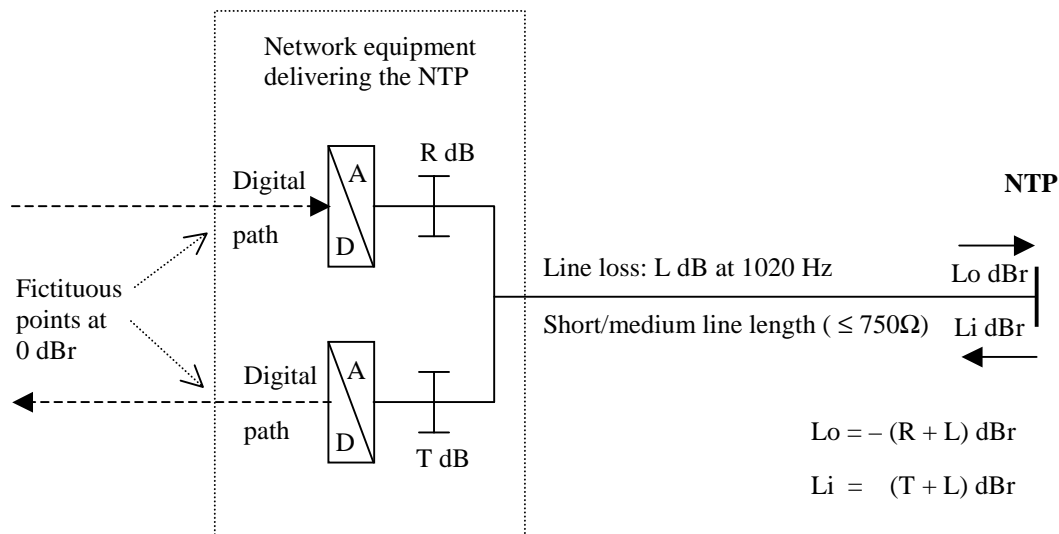

Figure 4: Relative levels

10.2 Frequency response

The nominal frequency band available at the NTP should be in line with ITU-T Recommendation Q.552 [18].

NOTE 1: It is assumed that the line card is designed according to ITU-T Recommendation Q.552 [18]. Where the line length is negligible, the frequency response at the NTP (when terminated with the reference impedance shown in figure 4) is about the same as for the line card itself.

NOTE 2: Attention is drawn to the need to accommodate voice band data applications which require a greater bandwidth for optimum operation (e.g. ITU-T Recommendation V.92 [21] modems). It is recommended that the bandwidth available be as wide as is practicable in order to accommodate such applications.

10.3 Coding law

Where other than A-law conversion according to ITU-T Recommendation G.711 [7] is used, this should be stated.

NOTE 1: The distortion depends on technology used to provide the path to the NTP. Where radio technology has been deployed, low bit rate coders are normally used. These usually produce a different type of distortion than A-law, and their effect on voice band data transmission may be greater than their effect on speech signals, and in some cases totally preventing voice band data operation.

NOTE 2: Low bit rate coders may also be used in other parts of the network. Cascading of low bit rate coders may further degrade speech and voice band data quality.

10.4 Noise

NOTE: The noise received at the NTP will depend on:

- noise generated by equipment in the network; and
- the amount of induced noise components on the line between the equipment delivering the NTP and the NTP itself.

It is recommended that the design of equipment delivering the NTP be in line with ITU-T Recommendation Q.552 [18] regarding noise performance of interfaces. The operator should specify the maximum level of noise appearing at the NTP regarding:

- a) in-band noise (psophometrically weighted);
- b) out-of-band signals where such information can be provided;
- c) noise at mains frequency (psophometrically weighted). For this aspect the objective of ITU-T Recommendation G.120 [20], clause 6.1 (noise induced by power lines) shall be taken into account.

10.5 Maximum input levels

With a sinusoidal signal having a level in the range from the reference level up to +5,7 dBm (see note 1 for clarification) applied at the NTP, the variation of gain with input level at the fictitious digital point (see figure 4) shall not be greater than $\pm 0,5$ dB relative to the gain at the reference level, which is either:

- -7,4 dBm (i.e. -13,1 dB below the highest point, see note 2), or
- -10 dBm₀ for the interface in question (see note 2).

NOTE 1: The overload point in a PCM A-law coder is +3,14 dBm₀. It is however not necessary that the input stage of a line card is able to handle higher signal levels than what is to be expected from a TE under normal conditions. TBR 021 [1] limits the value of instantaneous levels sent to the NTP from the TE to 5 V peak-to-peak. Assuming a sine wave signal, this corresponds to 1,8 V_{rms} which by ITU-T convention is equal to +5,7 dBm across Z_r (figure 3). Thus an NTP with a relative level of 2,6 dB_r and being capable of handling signals up to +3,14 dBm₀ without clipping, will also be able to handle signals coming from a TBR 021 [1] compliant TE.

NOTE 2: Variation of gain is defined in ITU-T Recommendation Q.552 [18]. The gain through an interface at different levels is compared to the gain at the reference level -10 dBm₀. Requirements in ITU-T Recommendation Q.552 [18] are set up to +3,14 dBm₀, i.e. 13,1 dB above the reference level.

NOTE 3: The present document allows for two alternative reference levels during testing to give more flexibility to the designer. The linearity of analogue to digital input stages at the levels in question are such that there will be very little difference in results between these two methods.

10.6 Stability

Stability in the network shall be maintained for AC open and short circuit conditions applied at the NTP.

NOTE: It is assumed that the design of equipment delivering the NTP is in line with ITU-T Recommendation Q.552 [18] regarding echo and stability performance of interfaces.

10.7 Crosstalk

The minimum crosstalk attenuation within the voice bandwidth between two pairs in the local network, one of them being the pair providing the NTP in question, shall be stated by the operator.

NOTE: It is assumed that the design of equipment delivering the NTP is in line with ITU-T Recommendation Q.552 [18] regarding crosstalk between interfaces.

11 DTMF Dialling

The network shall correctly interpret DTMF signals when received at the NTP with the following characteristics:

- a level within the range -5 dBV to -15 dBV (see note 1); and
- with a maximum difference in level between the high and low group tones of 6,0 dB; and

- with frequencies within $\pm (1,5 \% + 2 \text{ Hz})$ of the nominal values; and
- pulse duration greater than 40 ms and an inter-digital pause of not less than 40 ms.

The network shall ignore DTMF signals received at the NTP with a duration of less than 20 ms.

NOTE 1: Levels taken from the DTMF transmit level of TBR 021 [1] plus a small margin. The levels are not the same as in the DTMF receiver standard ES 201 235-3 [11], which specifies a reception range between -2 dBV to -28 dBV. The reason for this deviation is that the present document specifies requirements at the NTP where the line length to the terminal is very short (100 Ω). This means that the levels appearing at the NTP will be approximately the same as the levels transmitted from the terminal.

NOTE 2: See ES 201 235-1 [10] and ES 201 235-3 [11] for more information on DTMF receivers.

12 Ringing

NOTE: Guidance on generation of ringing signals may be found in TR 101 768 [2]. Guidance on ringing without DC may be found in TR 101 959 (see bibliography).

12.1 Ringing drive capability

12.1.1 Ringing frequency

The NTP shall provide a ringing supply with a nominal frequency of 25 Hz \pm 2 Hz and with a peak to rms voltage ratio in the range 1,2 to 1,6. The waveform shall be essentially symmetrical with an even order harmonic content not exceeding 5 %.

NOTE: Some terminals are designed to operate with 50 Hz ringing signals, a fact which should be taken into account.

12.1.2 Ringing voltage

The open circuit AC voltage shall not exceed 100 V_{rms} at the NTP.

The NTP shall provide sufficient ringing current so as to produce a voltage not less than 35 V_{rms} across an AC load of 400/LF k Ω , where LF is the stated LF arising from clause 5.2.2 (if individual LF-values are given as suggested by the note in clause 5.2.2, the LF is taken from table 2, "lowest impedance at 25 Hz").

NOTE 1: A single terminal equipment may present a load of 4 k Ω at the NTP. However, terminals normally present a considerably higher impedance at the NTP.

It is recommended that the ringing signal be balanced with respect to earth.

Fault conditions (during ringing) shall not damage the interface or the wiring connected.

NOTE 2: Examples of fault conditions are short circuit or unintended connections to earth.

12.1.2.1 Ringing with DC

If the AC ringing signal is superimposed on a DC voltage, the DC voltage shall be as specified in clause 6.2.

12.1.2.2 Ringing without DC

If the AC ringing signal is not superimposed on a DC voltage, the following shall apply:

- The DC voltage shall be presented during the off (silent) parts of the ring cadence.
- Requirement of clause 12.1.2 (supply \geq 35 V to a load of 400/LF k Ω) shall be tested with an AC load impedance with a modulus of 400/LF k Ω , and a phase angle of -70 degrees to -1 degrees.

For this test, a resistor with a value of $100\ \Omega$, representing the maximum length on the TE side, shall be connected between the NTP and the load specified above.

NOTE 1: It is expected that the TE show a capacitive load at 25 Hz (in the on-hook state).

NOTE 2: There are no requirements in TBR 021 [1] concerning the behaviour of TEs with ringing signals without a DC superimposed voltage, or the off-hook impedance of TEs at 25 Hz. As a consequence, it cannot be assured that a TE complying with TBR 021 [1] will correctly interwork with networks delivering AC ringing signals without a DC superimposed voltage. Increasing the ringing voltage from 35 Vrms to 55 Vrms (on the loads specified in clause 12.1.2) may improve the probability of correct interworking of these TEs in the area of ring detection where ringing is not superimposed on a DC component.

NOTE 3: A requirement on change from DC to ringing voltage is under study. Until such a requirement has been finalized, the following guidance (taken from TR 101 959 (see bibliography)) is given to designers:

The change from DC to ringing voltage shall be made in a smooth way. The best way to accomplish this is to start, and also to stop, with the ringing voltage when it has the same voltage level as the DC feeding voltage level (see figure 5), otherwise there could be transients due to loading and unloading of the TEs ringer capacitor at the beginning and the end of the ringing pulse. This transient has a steep slope and could disturb xDSL signals.

Draft requirement under study:

At the transition from DC line feed voltage to ringing voltage (and from ringing voltage to DC), the modulus of the change of the current to the load, measured in an infinite small time span ($|dI/dt|$), shall be less than 300 A/s. During the test, the NTP is terminated in an AC load impedance of $100\ \Omega$ at 25 Hz. For this test load the following network is proposed: $99\ \Omega + xx\ \text{nF}$ <under study>.

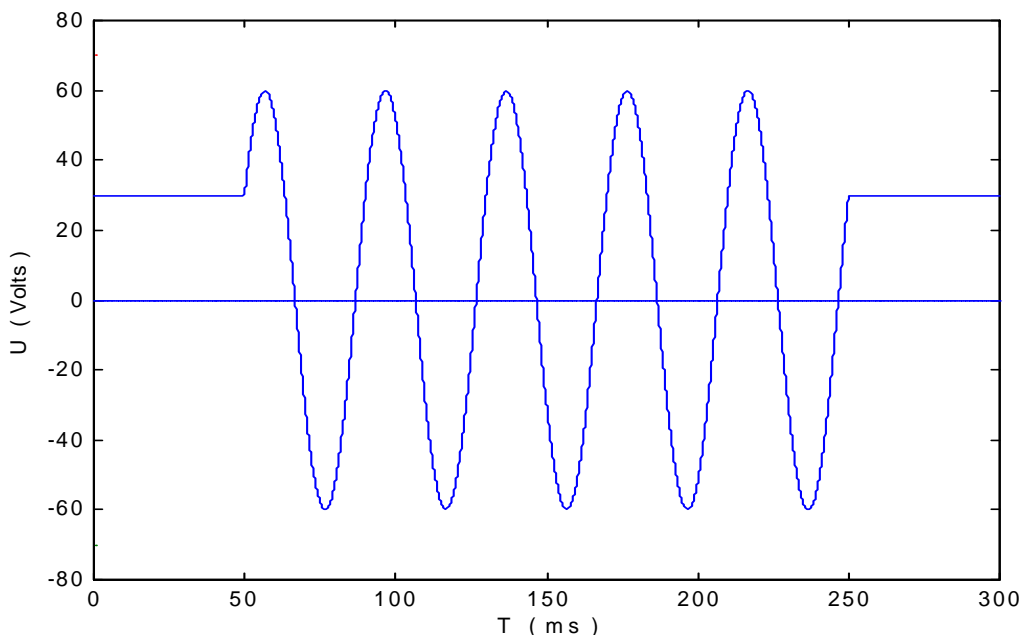

NOTE: To make the picture clearer, only 5 periods of the ringing voltage are shown.

Figure 5: Example of the principle of switching the ringing voltage on and off at the right moment

12.2 Ring cadence

The nominal ringing cadencing shall be 1 s on and 4 s off.

Other ringing cadences can be supplied as an option. Where provided, these shall be specified by the operator.

NOTE: Information of cadences frequently used in public networks is given in TR 101 183 [8].

12.3 Ring trip

Any ringing signal presented at the NTP shall be removed within 200 ms of an answer signal consisting of:

- a) a DC condition as defined in clause 7 being applied to the NTP; and
- b) for the case where the AC ringing signal is not superimposed on a DC voltage, an impedance not exceeding $700\ \Omega$ at 25 Hz applied at the NTP.

NOTE: Where the line length on the network side of the NTP is at its maximum according to the scope of the present document, the requirement in b) corresponds to an impedance of around $1\ 450\ \Omega$, when seen from the interface card of the terminating unit (which delivers the NTP).

12.4 False ring trip

For "ringing without DC", the network shall not recognize the ringing current as an "off-hook" condition when an impedance exceeding $1\ 500\ \Omega$ at 25 Hz is applied at the interface. This is tested with a test impedance having a modulus of $1\ 500\ \Omega$ and a phase angle of -70 degrees. This test impedance is composed of a resistor having a value of $513\ \Omega$ in series with a capacitor having a value of $4,52\ \mu\text{F}$. Tolerances for the resistor and capacitor shall be $\leq 2\ \%$.

NOTE: If the NTP is capable of supplying a 50 Hz ringing signal in addition, the testing of that feature should be done with the capacitor having a value of $2,26\ \mu\text{F}$.

13 Supervisory signals

Apart from the dial tone, other tones may be generated at locations other than the equipment delivering the NTP. Where tones are generated at the equipment delivering the NTP, the requirements of this clause apply.

NOTE 1: Further information on network generated tones may be found in TR 101 041-1 [14].

NOTE 2: The tones specified in this clause are in accordance with ITU-T Recommendation Q.35/E.180 [13].

13.1 Supervisory tones

The following types of supervisory tone shall be provided:

- a) dial tone;
- b) ringing tone;
- c) busy tone;

It is recommended that the following additional supervisory tones are also provided:

- d) release tone (if such a tone is used as specified in case a) of clause 8.2);
- e) special dial tone (often used to indicate the presence of messages waiting, or call forward activated);
- f) special information tone;
- g) call waiting tone;
- h) congestion tone.

13.2 Tone levels

The level of supervisory tones applied at the NTP into a reference impedance load Z_r as shown in figure 3, shall be within the range $-18\ \text{dBV}$ to $\pm 6\ \text{dBV}$.

13.3 Cadences and frequencies

Unless cadences and frequencies are in line with national supervisory signals, the following nominal values shall be used (where relevant in accordance with ITU-T Recommendation Q.35/E.180 [13]):

Table 6: Supervisory signals - Nominal cadences and frequencies

Tone	Cadence	Frequency
Dial tone	Continuous	425 Hz
Ringling tone	1 s on, 4 s off	425 Hz
Busy tone	0,5 s on, 0,5 s off	425 Hz
Special dial tone	0,5 s on, 0,05 s off	425 Hz
Special information tone (see note)	3 x 0,33 s on, 1 s off	950 Hz, 1 400 Hz, 1 800 Hz
Release tone	0,25 s on, 0,25 s off	425 Hz
Call waiting tone	0,2 s on, 0,2 s off, 0,2 s on, 9 s off	425 Hz
Congestion tone	0,25 s on, 0,25 s off	425 Hz

Tolerances for cadences are $\pm 10\%$ and for frequencies $\pm 1,5\%$.

NOTE: The above specification is consistent with current practice in a number of European countries. For clarification, the special information tone consists of a repetition of three sequential tones followed by a pause (950 Hz for 0,33 s, 1 400 Hz for 0,33 s, 1 800 Hz for 0,33 s, silence for 1 s).

14 Optional functions

14.1 Loop Disconnect dialling

The network shall correctly interpret Loop Disconnect (LD) signals applied at the NTP within the following limits:

- a) pulsing rate: 8 to 12 pulses per second;
- b) make to break ratio: break = 50 % to 75 % of the total pulse period;
- c) make current: loop current not less than 18 mA;
- d) break current: loop current not exceeding 2,5 mA;
- e) inter-digital pause (IDP): 240 ms minimum (see note 1).

NOTE 1: Terminals with automatic LD signalling will normally generate pulse trains with a maximum IDP of 920 ms. It is possible for terminals with manual LD signalling to exceed this limit.

NOTE 2: Information on the requirements for TE with LD signalling capability may be found in ES 201 187 [16].

14.2 Register recall

Except during loop disconnect dialling, the network shall recognize breaks in the loop current within the range 50 ms to 130 ms applied at the NTP as a register recall signal. The break period is the time for which the loop current is below 2,5 mA.

NOTE: Information on the requirements for TE with Register Recall signalling capability may be found in ES 201 729 [12].

14.3 Metering

If meter pulses using 12 kHz or 16 kHz signals are used the level between the A- and B-wires at the NTP shall be at least 100 mVrms, with cadences 100 ms / 100 ms ($\pm 30\%$ time values for a pulse packet and $\pm 1,5\%$ for frequency values), when measured with a termination of 200 Ω .

14.4 ALASS and other enhanced services

For the implementation of ALASS and other services, the requirements of EN 300 659, parts 1 [4] and 2 [5], shall be fulfilled.

It is recommended that in order to support the provision of ALASS services to the TE, the network should be capable of providing the NTP features selected from the list below, according to the implemented options:

- a) a single burst of ringing current with or without polarity reversal;
- b) provision of loop current up to 2,5 mA at a voltage greater than 32 V without it being treated as a seize signal;
- c) ignore on-line value DC current pulses not exceeding 25 ms duration, i.e. do not treat as a seize signal.

NOTE 1: More details may be found in EN 300 659-1 [4] for the NTP and EN 300 778 (see bibliography) for the TE. For the implementation of ALASS services these standards should be followed. By fulfilling the signalling requirements established in EN 300 659, parts 1 [4] and 2 [5], the interface may support enhanced services based on protocols specified in EN 300 659, parts 1 [4], 2 [5] and 3 [6] or other standards.

NOTE 2: ES 201 912 [24] standardizes the Short Message Service (SMS) for the User Based Solution (UBS), protocols for analogue TE of the PSTN/ISDN to communicate with the appropriate service centre. To implement such services no specific additional requirement is necessary in the present document, it is enough to fulfil the requirements of EN 300 659, parts 1 [4] and 2 [5].

NOTE 3: ES 201 071 [25] standardizes the Server Display and Script Services protocol (SDSS), which is also a protocol supporting enhanced services based on interfaces considered in the scope of the present document. To implement such services no specific additional requirement is necessary in the present document, it is enough to fulfil the requirements of EN 300 659, parts 1 [4] and 2 [5].

14.5 Polarity reversal

Where polarity reversal is provided, its purpose shall be specified.

NOTE 1: In order to ensure compatibility with the installed base of terminals in certain European networks it may be necessary to use polarity reversals to indicate start and end of ringing signal. In these cases, compatibility should be adequately ensured if the normal DC polarity is reversed when the first ringing voltage is applied. The polarity should revert to the normal polarity when the line is seized or cleared.

NOTE 2: Polarity reversal can be used to indicate called party answer and end-of-call.

NOTE 3: Polarity reversal can also be used for other signalling purposes (e.g. as given in EN 300 659, parts 1 [4] and 2 [5]).

14.6 End of call signal ("K-break")

An end-of-call signal consisting of a reduction in the PSTN loop current to below 1 mA for a certain period is referred to as K-break. Two times are suggested for the break:

- a) a range of 90 ms to 130 ms;
- b) a range of 250 ms to 300 ms. This is preferred for new equipment to avoid overlapping with the register recall signal (see clause 14.2).

14.7 Payphones

There may be a need to adapt certain parameters at the NTP in order to support a wide range of payphones available on the market. These aspects are for further study.

Annex A (informative): Bibliography

ETSI EN 300 778 (parts 1 and 2): "Access and Terminals (AT); Analogue access to the Public Switched Telephone Network (PSTN); Protocol over the local loop for display and related services; Terminal equipment requirements".

ANSI/TIA/EIA/IS-968: "Telecommunications - Telephone Terminal Equipment - Technical Requirements for Connection of Terminal Equipment to the Telephone Network".

NOTE: The above document can be obtained from:
Telecommunications Industry Association 2500 Wilson Blvd., Suite 300 Arlington, VA 22201 USA
ph: (703) 907-7700
fx: (703) 907-7727.

ETSI TR 101 959: "Access and Terminals (AT); Study on Ringing without DC (For TE and Terminal Support Interfaces)".

History

Document history		
V1.1.1	May 2002	Membership Approval Procedure MV 20020726: 2002-05-28 to 2002-07-26