

**Digital Audio Broadcasting (DAB);
Interaction channel through Global System
for Mobile communications (GSM)
the Public switched Telecommunications System (PSTN);
Integrated Services Digital Network (ISDN)
and Digital Enhanced Cordless Telecommunications (DECT)**

European Broadcasting Union



Union Européenne de Radio-Télévision

DAB
Digital Audio Broadcasting



Reference

DES/JTC-DAB-17

Keywordsbroadcast, broadcasting, DAB, DECT, digital,
GSM, ISDN, PSTN**ETSI**

Postal address

F-06921 Sophia Antipolis Cedex - FRANCE

Office address650 Route des Lucioles - Sophia Antipolis
Valbonne - FRANCE
Tel.: +33 4 92 94 42 00 Fax: +33 4 93 65 47 16
Siret N° 348 623 562 00017 - NAF 742 C
Association à but non lucratif enregistrée à la
Sous-Préfecture de Grasse (06) N° 7803/88

Internet

secretariat@etsi.fr

Individual copies of this ETSI deliverable
can be downloaded from
<http://www.etsi.org>If you find errors in the present document, send your
comment to: editor@etsi.fr

Important notice

This ETSI deliverable may be made available in more than one electronic version or in print. In any case of existing or perceived difference in contents between such versions, the reference version is the Portable Document Format (PDF). In case of dispute, the reference shall be the printing on ETSI printers of the PDF version kept on a specific network drive within ETSI Secretariat.

Copyright Notification

No part may be reproduced except as authorized by written permission.
The copyright and the foregoing restriction extend to reproduction in all media.

© European Telecommunications Standards Institute 2000.
© European Broadcasting Union 2000.
All rights reserved.

Contents

Intellectual Property Rights	5
Foreword	5
1 Scope	6
2 References	6
3 Abbreviations	8
4 Reference models	9
4.1 Protocol stack model	9
4.2 System model	10
5 DAB interaction channel specification for GSM.....	11
5.1 Physical interfaces	12
5.1.1 External MS	12
5.1.2 Integrated MS	12
5.2 Calling procedures.....	12
5.3 Forced disconnection.....	12
6 DAB interaction channel specification for PSTN.....	13
6.1 Physical interfaces between the modem, the user terminal and PSTN	13
6.1.1 External modem	13
6.1.2 Integrated modem	13
6.2 Calling procedures.....	13
6.2.1 Dialling	13
6.2.2 Line monitoring	13
6.3 Call attempt when service provider line is busy	13
6.4 Forced disconnection during dialling or data transfer	14
7 DAB interaction channel specification for ISDN	14
7.1 Physical interface for connection to ISDN BRA	14
7.2 Calling procedures.....	14
7.3 Forced disconnection.....	14
8 DAB interaction channel specification for DECT	14
8.1 System architecture.....	14
8.2 Physical interfaces	15
8.3 Calling procedures.....	15
8.4 DECT profiles	15
8.4.1 Recommended DECT profiles when the DECT infrastructure is external to the home	16
8.4.2 Recommended DECT profiles when the DECT infrastructure is internal to the home.....	16
8.5 Forced disconnection.....	17
9 Modem interfaces	17
9.1 PSTN modem	17
9.2 External modem.....	17
9.2.1 DTE/DCE interface	17
9.3 Integrated modem.....	18

Annex A (informative):	Basic characteristics of GSM.....	19
A.1	GSM - general	19
A.2	Future GSM data services	19
Annex B (informative):	Interworking types	20
B.1	Interworking to PSTN.....	20
B.2	Interworking to ISDN.....	21
Annex C (informative):	Basic characteristics of DECT.....	22
C.1	DECT introduction.....	22
C.2	The DECT standard	22
C.2.1	Physical (PHL) layer	23
C.2.2	Medium Access Control (MAC) layer.....	24
C.2.3	Data Link Control (DLC) layer	24
C.2.4	Network (NWK) layer	24
C.2.5	Lower Layer Management Entity (LLME).....	25
C.2.6	Interworking Units (IWU).....	25
C.3	Profiles	25
C.3.1	The Radio in the local loop Access Profile (RAP)	25
C.3.2	The Data Services Profiles (DSP's)	27
C.3.3	The PPP interworking DSP	28
C.4	Wireless Relay Station	28
C.5	DECT Authentication module (DAM).....	28
	Bibliography	29
	History	30

Intellectual Property Rights

IPRs essential or potentially essential to the present document may have been declared to ETSI. The information pertaining to these essential IPRs, if any, is publicly available for **ETSI members and non-members**, and can be found in SR 000 314: *"Intellectual Property Rights (IPRs); Essential, or potentially Essential, IPRs notified to ETSI in respect of ETSI standards"*, which is available from the ETSI Secretariat. Latest updates are available on the ETSI Web server (<http://www.etsi.org/ipr>).

Pursuant to the ETSI IPR Policy, no investigation, including IPR searches, has been carried out by ETSI. No guarantee can be given as to the existence of other IPRs not referenced in SR 000 314 (or the updates on the ETSI Web server) which are, or may be, or may become, essential to the present document.

Foreword

This ETSI Standard (ES) has been produced by the Joint Technical Committee (JTC) Broadcast of the European Broadcasting Union (EBU), Comité Européen de Normalisation ELECTrotechnique (CENELEC) and the European Telecommunications Standards Institute (ETSI).

NOTE: The EBU/ETSI JTC Broadcast was established in 1990 to co-ordinate the drafting of standards in the specific field of broadcasting and related fields. Since 1995 the JTC Broadcast became a tripartite body by including in the Memorandum of Understanding also CENELEC, which is responsible for the standardization of radio and television receivers. The EBU is a professional association of broadcasting organizations whose work includes the co-ordination of its members' activities in the technical, legal, programme-making and programme-exchange domains. The EBU has active members in about 60 countries in the European broadcasting area; its headquarters is in Geneva.

European Broadcasting Union
CH-1218 GRAND SACONNEX (Geneva)
Switzerland
Tel: +41 22 717 21 11
Fax: +41 22 717 24 81

1 Scope

The present document is the baseline for the provision of an Interaction Channel (IC also known as Feed Back Channel (FBC)) to Digital Audio Broadcasting (DAB) ETS 300 401 [6]. The document includes the network dependent parts of the IC, for the GSM, PSTN, ISDN and DECT systems. The network independent protocols for the IC are specified within a separate document Eureka Project 147 [36].

In the process of producing the present document the specifications for an Interaction Channel for Digital Video Broadcasting (DVB) has carefully been studied. The goal has been to as far as possible be compatible with the DVB solutions thereby creating a common concept of treating the combination broadcast-/telecommunication system. The solutions provided here for an IC through GSM/PSTN/ISDN/DECT are only a part of a wider set of alternatives possible in order to implement interactive services for DAB systems.

2 References

The following documents contain provisions which, through reference in this text, constitute provisions of the present document.

- References are either specific (identified by date of publication, edition number, version number, etc.) or non-specific.
- For a specific reference, subsequent revisions do not apply.
- For a non-specific reference, the latest version applies.
- A non-specific reference to an ETS shall also be taken to refer to later versions published as an EN with the same number.

- [1] ES 201 736: "Digital Audio Broadcasting (DAB) Network Independent Protocols for Interactive Services".
- [2] EN 300 001: "Attachments to the Public Switched Telephone Network (PSTN); General technical requirements for equipment connected to an analogue subscriber interface in the PSTN".
- [3] EN 300 444: "Digital Enhanced Cordless Telecommunications (DECT); Generic Access Profile (GAP)".
- [4] EN 301 240: "Digital Enhanced Cordless Telecommunications (DECT); Data Services Profile (DSP); Point-to-Point Protocol (PPP) interworking for internet access and general multi-protocol datagram transport".
- [5] ETS 300 012: "Integrated Services Digital Network (ISDN); Basic user-network interface Layer 1 specification and test principles".
- [6] ETS 300 401: "Radio broadcasting systems; Digital Audio Broadcasting (DAB) to mobile, portable and fixed receivers".
- [7] ETS 300 402: "Integrated Services Digital Network (ISDN); Digital Subscriber Signalling System No. one (DSS1) protocol; Data link layer; [ITU-T Recommendation Q.921 (1993), modified]".
- [8] ETS 300 403: "Integrated Services Digital Network (ISDN); Digital Subscriber Signalling System No. one (DSS1) protocol; Signalling network layer for circuit-mode basic call control; [ITU-T Recommendation Q.931 (1993), modified]".
- [9] ETS 300 501: "European digital cellular telecommunications system (Phase 2); Bearer Services (BS) supported by a GSM Public Land Mobile Network (PLMN) (GSM 02.02)".
- [10] ETS 300 556: "European digital cellular telecommunications system (Phase 2); Mobile radio interface signalling layer 3; General aspects (GSM 04.07)".

- [11] ETS 300 557: "European digital cellular telecommunications system (Phase 2); Mobile radio interface; Layer 3 specification (GSM 04.08)".
- [12] ETS 300 582: "Digital cellular telecommunications system (Phase 2); General on Terminal Adaptation Functions (TAF) for Mobile Stations (MS) (GSM 07.01)".
- [13] ETS 300 583: "European digital cellular telecommunications system (Phase 2); Terminal Adaptation Functions (TAF) for services using asynchronous bearer capabilities (GSM 07.02)".
- [14] ETS 300 586: "European digital cellular telecommunications system (Phase 2); Use of the V series Data Terminal Equipment - Data Circuit terminating Equipment (DTE - DCE) interface at the Mobile Station (MS) for Mobile Termination (MT) configuration (GSM 07.06)".
- [15] ETS 300 600: "European digital cellular telecommunications system (Phase 2); Signalling requirements on interworking between the Integrated Services Digital Network (ISDN) or Public Switched Telephone Network (PSTN) and the Public Land Mobile Network (PLMN) (GSM 09.03)".
- [16] ETS 300 604: "Digital cellular telecommunications system (Phase 2); General requirements on interworking between the Public Land Mobile Network (PLMN) and the Integrated Services Digital Network (ISDN) or Public Switched Telephone Network (PSTN) (GSM 09.07 version 4.13.1)".
- [17] ETS 300 651: "Digital Enhanced Cordless Telecommunications (DECT); Data Services Profile (DSP); Generic data link service (service type C, class 2)".
- [18] ETS 300 700: "Digital Enhanced Cordless Telecommunications (DECT); Wireless Relay Station (WRS)".
- [19] ETS 300 701: "Digital Enhanced Cordless Telecommunications (DECT); Data Services Profile (DSP); Generic frame relay service with mobility (service types A and B, class 2)".
- [20] ETS 300 765-1: "Digital Enhanced Cordless Telecommunications (DECT); Radio in the Local Loop (RLL) Access Profile (RAP); Part 1: Basic telephony services".
- [21] ETS 300 765-2: "Digital Enhanced Cordless Telecommunications (DECT); Radio in the Local Loop (RLL) Access Profile (RAP); Part 2: Advanced telephony services".
- [22] ETR 185: "Digital Enhanced Cordless Telecommunications (DECT); Data Services Profile (DSP); Profile overview".
- [23] ETR 308: "Digital Enhanced Cordless Telecommunications (DECT); Services, facilities and configurations for DECT in the local loop".
- [24] CCITT Recommendation V.21 (1984): "300 bits per second duplex modem standardized for use in the general switched telephone network".
- [25] CCITT Recommendation V.22 (1988): "1 200 bits per second duplex modem standardized for use in the general switched telephone network and on point-to-point 2-wire leased telephone-type circuits".
- [26] CCITT Recommendation V.22bis (1988): "2 400 bits per second duplex modem using the frequency division technique standardized for use on the general switched telephone network and on point-to-point 2-wire leased telephone-type circuits".
- [27] CCITT Recommendation V.23 (1988): "600/1 200-band modem standardized for use in the general switched telephone network".
- [28] ITU-T Recommendation V.25 (1996): "Automatic answering equipment and general procedures for automatic calling equipment on the general switched telephone network including procedures for disabling of echo control devices for both manually and automatically established calls".

- [29] ITU-T Recommendation V.32 (1993): "A family of 2-wire, duplex modems operating at data signalling rates of up to 9 600 bit/s for use on the general switched telephone network and on leased telephone-type circuits".
- [30] ITU-T Recommendation V.32bis (1991): "A duplex modem operating at data signalling rates of up to 14 400 bit/s for use on the general switched telephone network and on leased point-to-point 2-wire telephone-type circuits".
- [31] ITU-T Recommendation V.34 (1998): "A modem operating at data signalling rates of up to 33 600 bit/s for use on the general switched telephone network and on leased point-to-point 2-wire telephone-type circuits".
- [32] ITU-T Recommendation V.42 (1996): "Error-correcting procedures for DCEs using asynchronous-to-synchronous conversion".
- [33] ITU-T Recommendation V.42bis (1990): "Data compression procedures for data circuit-terminating equipment (DCE) using error correcting procedures".
- [34] ETS 300 175 (all parts): "Digital Enhanced Cordless Telecommunications (DECT); Common Interface (CI)".
- [35] DE/RES-03039: "Radio Equipment and Systems (RES); Digital European Telecommunications (DECT); DECT-ISDN interworking profile, Intermediate system configuration Part 2: ISDN Access Profile Intermediate-System".
- NOTE: Not yet published.
- [36] EUREKA Project 147 (1997): "Digital Audio Broadcasting System: Definition of the Service Transport Interface".

3 Abbreviations

For the purposes of the present document, the following abbreviations apply:

AT	Attention
BC	Broadcast Channel
BC-IE	Bearer Capability Information Element
BRA	Basic Rate Access
BSC	Base Station Controller
BTS	Base Transceiver Station
CCITT	Consultative Committee of the International Telegraph and Telephone
CI	Common Interface
CTA	Cordless Terminal Adapter
DAB	Digital Audio Broadcasting
DAB-RM	Digital Audio Broadcasting Receiver Module
DAM	DECT Authentication Module
DAVIC	Digital Audio Visual Council
DCE	Data Circuit-terminating Equipment
DECT	Digital Enhanced Cordless Telecommunications
DLC	Data Link Control
DSP	Data Services Profile
DTE	Data Terminal Equipment
DTMF	Dual Tone Multi Frequency (dialling mode)
DVB	Digital Video Broadcasting
EN	European Norm
ETS	European Telecommunication Standard
ETSI	European Telecommunications Standards Institute
FBC	Feed Back Channel
FP	Fixed Part
GAP	Generic Access Profile
GMSK	Gaussian Minimum Shift Keying

GSM	Global System for Mobile Communications
GSTN	General Switched Telephone Network
HLC	High level Link Control
HSCSD	High-Speed Circuit-Switched Data
IC	Interaction Channel
IM	Interaction Module
INA	Interactive Network Adapter
ISDN	Integrated Switched Digital Network
ISO	International Standards Organization
ITU	International Telecommunications Union
ITU-T	International Telecommunications Union - Telecommunications Standardization Sector
IWF	Interworking Function
IWU	Interworking Unit
LAP	Link Access Protocol
LLC	Logical Link Control
LLME	Lower Layer Management Entity
MAC	Medium Access Control
MMI	Man Machine Interface
MO	Mobile Originated
MO/PP	Mobile Originated/Point-to-Point
MS	Mobile Station
MSC	Mobile Switching Centre
MT	Mobile Termination
MT/PP	Mobile Termination/Point-to-Point
NWK	Network Layer
OSI	Open Systems Interconnection
PHL	Physical Layer
PLMN	Public Land Mobile Network
PP	Portable Part
PPP	Point-to-Point Protocol
PSTN	Public Switched Telephone Network
RA	Radio Access
RAP	Radio in the local loop Access Profile
RLL	Radio in the Local Loop
SIM	Subscriber Identity Module
SMS	Short Message Service
SMS-SC	SMS Service Centre
SP	Service Provider
TAF	Terminal Adaptation Function
TDMA	Time Division Multiple Access
TE	Terminal Equipment
UT	User Terminal
WRS	Wireless Relay Station

4 Reference models

4.1 Protocol stack model

For asymmetric interactive services supporting broadcast to mobile/portable/stationary receivers with a narrow band interaction channel, a simple communication model consists of the following layers:

Application layer: is the interactive application software and runtime environments (e.g. home shopping application, script interpreter, etc.).

Transport layer: defines all the relevant data structures and communication protocols.

Physical layer: where all the physical (electrical) transmission parameters are defined.

The present document addresses the lower two layers (the physical and transport) leaving the application layer open to competitive market forces. It is not the role of the document to define standardized applications.

A simplified model of the OSI layers is adopted to facilitate the production of specifications for these nodes. Figure 1 points out the lower layers of the simplified model and identifies some of the key parameters for the lower two layers. Following the user requirements for interactive services, no attempt will be made to consider higher layers in the present document.

Layer Structure for Generic System Reference Model

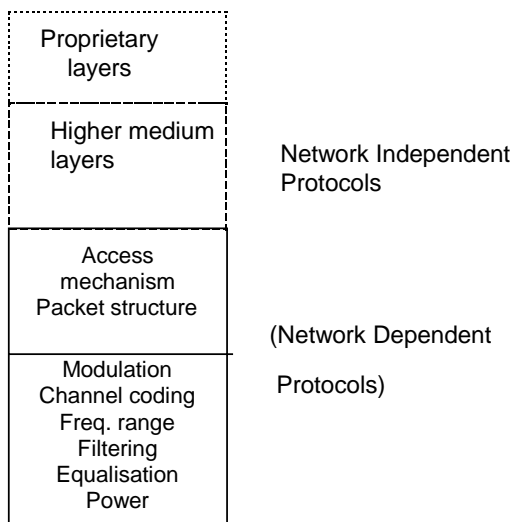

Figure 1: Layer structure for generic system reference model

The present document addresses the GSM/PSTN/ISDN/DECT network specific aspects only. The network independent protocols will be specified separately ES 201 736 [1].

4.2 System model

Figure 2 shows the system model which is to be used within DAB for interactive services.

In the system model, two channels are established between the service provider and the end user:

Broadcast Channel (BC): an unidirectional broadband broadcast channel that can include audio, low bit-rate video and different types of data. The BC is established from the service provider to the end users. It may include the forward interaction path in other words distributing individually addressed data to the end user.

Interaction Channel (IC): an interaction channel is established between the service provider and the end user for interaction purposes. It is formed by:

- **return interaction path** (return channel): from the end user to the service provider. It is used for instance to make requests to the service provider or to answer questions. In most cases it is a narrow-band channel also commonly known as return channel or Feed Back Channel (FBC);
- **forward interaction path:** from the service provider to the end user. It is used to provide some sort of individually addressed information by the service provider to the end user and any other required communication for the interactive service provision. It may be embedded into the broadcast channel. It is possible that this channel is not required in some simple implementations which make use of the BC for the carriage of data to the end user.

The user terminal is formed by the DAB Receiver Module (DAB-RM), the Interaction Module (IM), the Man Machine Interface (MMI) and the application module. The user terminal provides interface for both broadcast and interaction channels. The interface between the user terminal and the interaction network is via the interaction module.

The interface between the broadcast channel and the user terminal is via the DAB-RM.

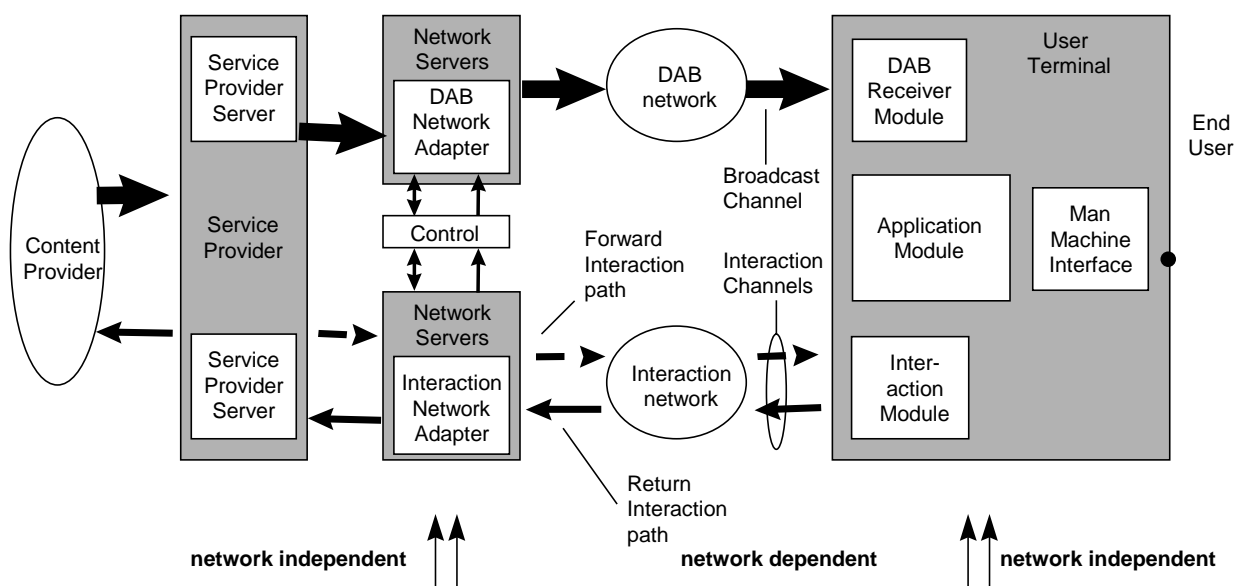

Figure 2: A generic system reference model for interactive systems based on DAB

5 DAB interaction channel specification for GSM

A GSM infrastructure can support the implementation of the IC for DAB broadcasting systems, by providing a wireless bi-directional communication path between the user terminal and an infrastructure connecting to the service provider.

GSM is a wireless access technology which constitutes the whole or a part of the interaction network. The GSM network may be complemented with another network to reach the service provider (commonly PSTN/ISDN).

In order to allow the access to the GSM network, the user terminal shall be provided with a GSM Interaction Module (IM) referred to as a Mobile Station (MS). The interface between the MS and the GSM network shall be compliant with the standard requirements on general on Terminal Adaptation Functions (TAF) for Mobile Stations (MS) as reported in ETS 300 582 [12] and TAF for services using asynchronous bearer capabilities ETS 300 583 [13].

The interface between the GSM network and the external network to provide the whole Interaction channel shall be compliant with the general and signalling requirements on interworking between the GSM network and the ISDN or PSTN as reported in ETS 300 604 [16] and ETS 300 600 [15].

Depending on the network linking (if used) the GSM network to the service provider, the mobile station should be configured to support the right bearer capabilities. In annex B the interworking functions for PSTN and ISDN are described for informative purposes. When possible it is preferential to implement GSM-ISDN interworking, which provides an end to end digital link between the IM and the INA with lower connection set-up times.

The basic characteristics of GSM are described in annex A.

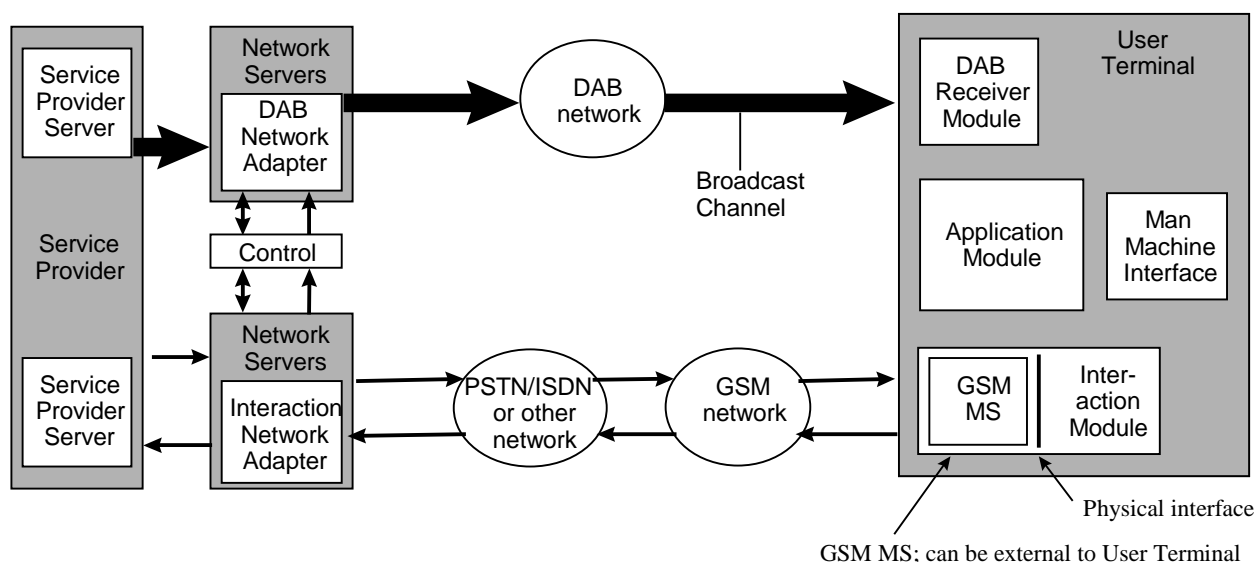

Figure 3: System architecture when GSM is used as the interaction channel

5.1 Physical interfaces

The physical interfaces relate to how the GSM MS is connected to the user terminal. It applies to user terminals with internal or external MS.

5.1.1 External MS

The interfaces requirements between the user terminal (DTE) and the MS (DCE) according to ETS 300 586 [14] and in the same way as described in clause 9 for "modem interface" shall be supported.

5.1.2 Integrated MS

The internal MS shall meet the same requirements as the external MS with the exception of providing the 9-pin interface connector.

5.2 Calling procedures

The connection to the GSM network shall be established according to GSM 04 series. The signalling protocols are described in "Mobile Radio Interface; Layer 3 Specification" ETS 300 557 [11]. In case the service provider is not reachable because any reason (line is busy, coverage issues, channel availability, etc.) the upper layers will be responsible to repeat the calling attempts and/or inform to the user.

5.3 Forced disconnection

Disconnection for emergency calls can be implemented by the upper layer protocols using the signalling channel.

6 DAB interaction channel specification for PSTN

The PSTN infrastructures can support the implementation of the IC for interactive services suitable for DAB broadcasting systems. PSTN can be used to implement interactive services in the DAB environment, providing a bi-directional communication path between the user terminal and the service provider by means of a modem.

In order to allow the access to the PSTN, the UT shall be provided with a modem (internal or external to the user terminal). The modem constitutes the user interface module to the interaction network. The modem will be connected to the PSTN through the existing telephone line. Therefore it will share the line with other terminals/equipment already present at the customer premises (telephones, facsimile, other modems, etc.).

The interface between modem and PSTN shall be compliant with the national requirements for the terminal equipment as reported in EN 300 001 [2].

6.1 Physical interfaces between the modem, the user terminal and PSTN

The physical interfaces between the modem, the user terminal and PSTN are described in this subclause. It applies to user terminals with internal or external modem.

6.1.1 External modem

The interfaces requirements between the user terminal (data termination equipment) and the modem (data communication equipment) as described in clause 9 shall be supported. The external modem shall support the PSTN link interface as described in clause 9.

6.1.2 Integrated modem

The internal modem shall meet the same requirements as the external modem.

6.2 Calling procedures

The connection to PSTN shall be established according to the rules specified in the document EN 300 001 [2], with reference to the specific national requirements.

6.2.1 Dialling

The modem will use DTMF (Dual Tone Multi Frequency) dialling mode according to EN 300 001 [2].

Optionally pulse dialling mode can be used according to EN 300 001 [2].

6.2.2 Line monitoring

The modem shall be able to identify the status of the line ("on-hook" status or "off-hook" status).

When the line is engaged ("off-hook" status) the modem shall perform a call repetition procedure according to the distribution specified in EN 300 001 [2].

6.3 Call attempt when service provider line is busy

The modem will execute multiple call attempts in response of "busy line" signal from the service provider. If these call attempts are addressed to the same service provider number, they shall be distributed in time according to EN 300 001 [2].

6.4 Forced disconnection during dialling or data transfer

The content of this sub clause is necessary only for those European countries where the users capability to interrupt an active communication at any time is not provided by the PSTN. In this case the capability of interrupting an active communication shall be provided cutting off the connection by the calling device.

It is recognized that in some European countries it should be guaranteed that the user can interrupt the communication at any time. During dialling or data transfer phases, the modem connection shall be cut off and the modem shall perform a forced disconnection if the user hooks off any of the other terminals connected to the same line. This functionality is requested in order to enable emergency calls.

The modem shall be able to set-up the connection when requested from the User Terminal. If it is not possible for the modem to interrupt the interaction when it is the called party, the modem itself shall not accept incoming calls from any service provider (AUTOANSWERING function disabled). The call establishing the bi-directional return channel is in this case always initiated by the modem towards the service provider.

As an alternative option the modem can act as the called party in user terminals where the application layer includes a means of closing down the interaction channel from the server.

7 DAB interaction channel specification for ISDN

The ISDN infrastructures can support the implementation of the interaction channel for interactive services suitable for DAB broadcasting systems. ISDN can be used to implement interactive services in DAB environment, providing a bi-directional communication path between the user terminal and the service provider. ISDN BRA (Basic Rate Access) can be used.

7.1 Physical interface for connection to ISDN BRA

The physical interface to connect to ISDN BRA shall be as described in ETS 300 012 [5].

7.2 Calling procedures

The signalling protocols for ISDN BRA shall be as described in ETS 300 402 [7] and ETS 300 403 [8].

7.3 Forced disconnection

Disconnection for emergency calls can be implemented by the upper layer protocols using the signalling channel (D channel).

8 DAB interaction channel specification for DECT

A DECT infrastructure can support the implementation of the interaction channel for DAB broadcasting systems, by providing a wireless bi-directional communication path between the user terminal and an infrastructure connecting to the service provider. The basic characteristics of DECT are described in annex C.

8.1 System architecture

The IM (Interaction Module) is implemented through a DECT PP (Portable Part), see figure 4. The DECT PP can be internal or external to the user terminal.

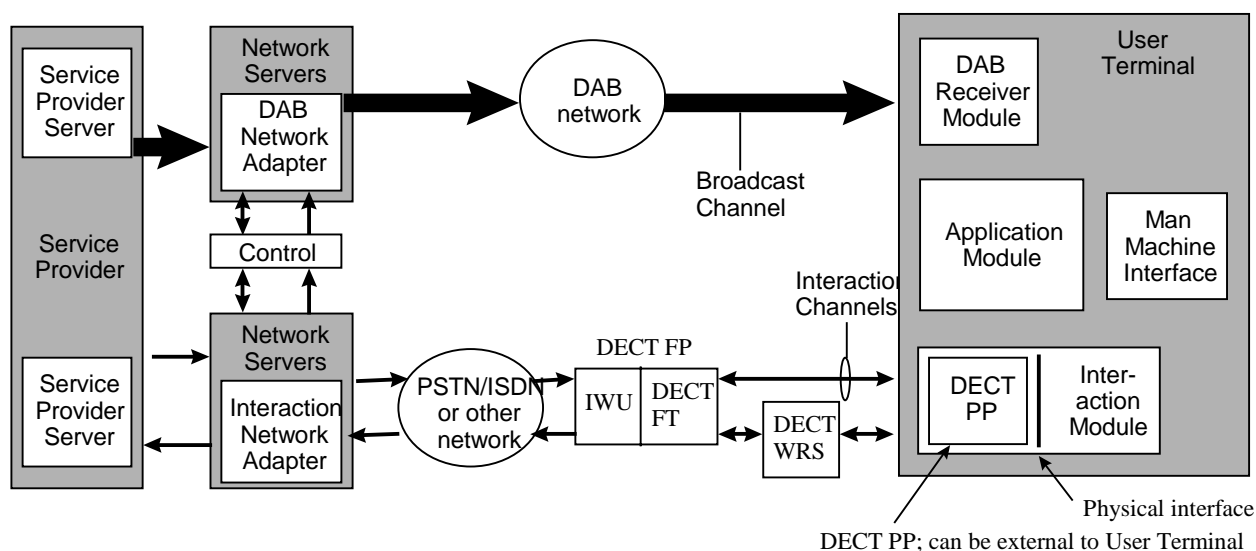

Figure 4: System architecture when DECT is used as the interaction channel

DECT is a wireless access technology, not a complete network or system. Therefore, DECT FP's (Fixed Parts) are part of the interaction network. A DECT FP includes an IWU (Interworking Unit) which handles the interconnection of DECT with the INA via another interaction network.

8.2 Physical interfaces

The physical interfaces relate to how the DECT PP is connected to the interaction module, how the DECT FP is connected to other interaction networks and the wireless physical interfaces between DECT PP's, DECT FP's and DECT WRS's (Wireless Relay Stations). The DECT profiles specify the physical interfaces for different services and applications, see subclause 8.4.

In the case of a DECT PP external to the user terminal, the interfaces are described in clause 9.

8.3 Calling procedures

The signalling protocols are specified by the DECT profiles, see subclause 8.4.

8.4 DECT profiles

The connection of DECT to different networks, the operation of the DECT air interface and the signalling protocols for specific services and applications are described in the DECT profiles. A DAB operator using DECT as the interaction channel should use DECT profiles. Several DECT profiles can be supported in a DECT system, which means that other profiles can be supported in parallel with the profile used to carry the DAB network independent protocols for interactive services ES 201 736 [1].

The default implementations described in subclauses 8.4.1 and 8.4.2 are based on the Radio in the local loop Access Profile (RAP) ETS 300 765-2 [21] and the Data Services Profile (DSP) PPP interworking EN 301 240 [4]. The RAP offers valuable operation and maintenance functions. DSP PPP interworking offers effective handling of data traffic and describes the interworking to different fixed networks. When accessing an external DECT infrastructure, RAP functions are used in combination with the DSP PPP interworking.

Due to the flexible nature of the DECT standards, several other implementation possibilities exist.

8.4.1 Recommended DECT profiles when the DECT infrastructure is external to the home

The RAP, ETS 300 765-1 [20] and ETS 300 765-2 [21], describes how DECT is used in Radio in the Local Loop (RLL) scenarios. It is recommended that the IM is represented by a DECT PP internal to the STB with a RAP Data service ETS 300 765-2 [21] according to the DSP PPP interworking EN 301 240 [4] implemented, when the interaction channel is through a DECT infrastructure, external to the home, see figure 5. The DECT PP (IM) communicates with a DECT RAP data service (DSP PPP interworking) infrastructure comprised of FP's and possible WRS's ETS 300 700 [18]. A WRS relays intelligently the DECT signals between DECT FP's and DECT PP's. This User Terminal (UT) implementation should be the default implementation when DECT is used as the interaction channel in DAB.

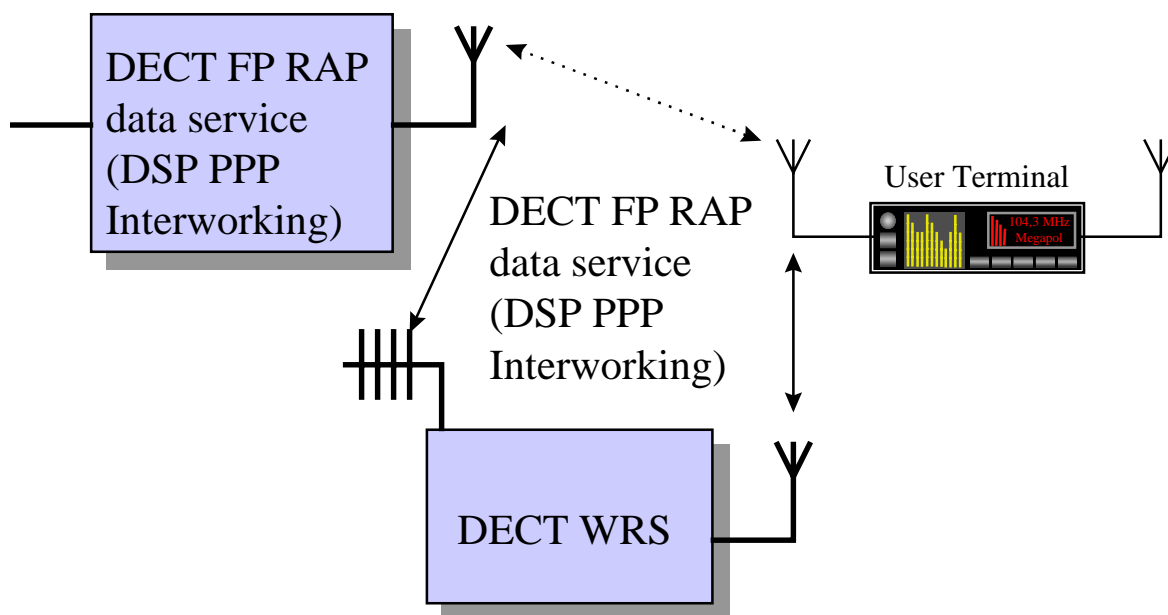

Figure 5: Default implementation of an interaction channel through a DECT infrastructure, external to the home

In figure 5 a DECT PP, supporting a RAP data service (DSP PPP interworking), is implemented in the UT. The UT communicates either directly with an FP (dashed line) or via a WRS (unbroken line). The WRS can be located internal to the home.

8.4.2 Recommended DECT profiles when the DECT infrastructure is internal to the home

DECT can be used in the home as a wireless interface to a network. In figure 6, a home DECT FP is connected to a fixed network interface and provides the UT with a wireless Interaction Channel. The DECT User Terminal implementation is the same as when the DECT FP is external to the home. The DECT PP RAP data service (DSP PPP interworking) terminal should notice that the home FP does not support RAP features, and therefore not use the RAP procedures. This UT implementation should be the default implementations when DECT is used as the IC in DAB.

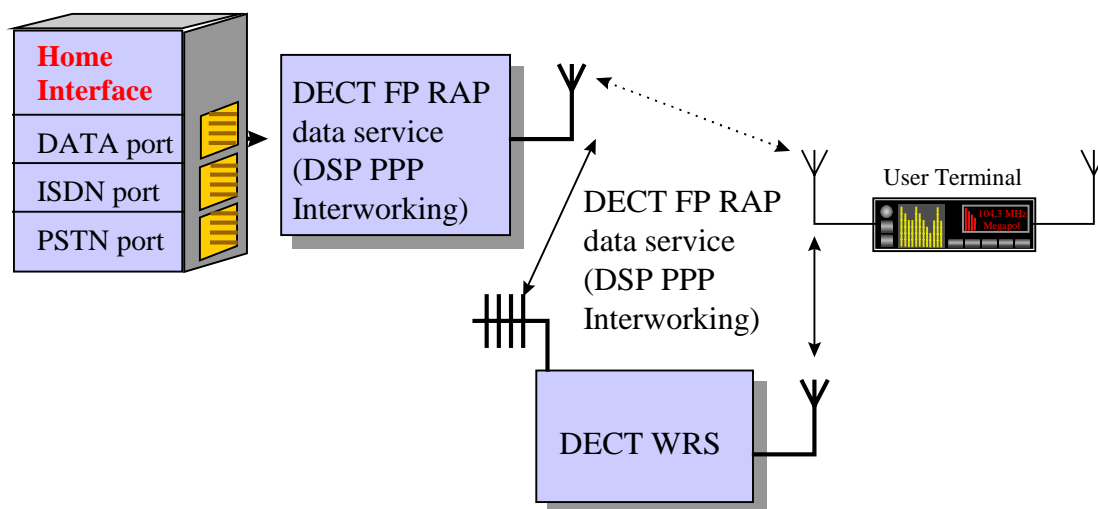

Figure 6: Default implementation of an Interaction Channel through a DECT infrastructure, internal to the home.

In figure 6 a DECT PP, supporting a RAP data service (DSP PPP interworking), is implemented in the User Terminal. The UT communicates either directly with an FP (dashed line) or via a WRS (unbroken line).

8.5 Forced disconnection

In an implementation incorporating connections to the PSTN, the communication on the interaction channel should not block an emergency call attempt. The DECT profiles allow this functionality in several ways. If not implemented, the application should allow a forced disconnection in the case of an emergency call.

9 Modem interfaces

9.1 PSTN modem

A PSTN modem interface provides a low bit rate data channel.

9.2 External modem

9.2.1 DTE/DCE interface

The modem shall support:

- a) an interface lead with a 9-pin or 25-pin D-type connector with male shell and female contacts, using RS232C interface levels. The DAB-terminal is seen as the Data Termination Equipment (DTE) and shall be equipped with the mating connector. The pin arrangement shall be as follows:

Table 1

9-pin	25-pin	assignment		source
1	8	DCD	(Data carrier detect)	modem
2	3	RX	(Receiver data)	modem
3	2	TX	(Transmitter data)	terminal
4	20	DTR	(Data terminal ready)	terminal
5	7	GND	(Signal ground)	
6	6	DSR	(Data set ready)	modem
7	4	RTS	(Request to send)	terminal
8	5	CTS	(Clear to send)	modem
9	22	RI	(Ring indicator)	modem

- b) auto mode selection CCITT Recommendations V.21 [24], V.22 [25], V.22bis [26] or V.23 [27] transmission protocols (one of these as a minimum). Asynchronous working with one or two stop bits and with or without parity shall be possible. It is recommended that ITU-T Recommendations V.32 [29], V.32bis [30] and V.34 [31] support is included and that the design does not preclude the addition of future enhancements;
 - c) hardware flow control (RTS/CTS) in addition to XON/XOFF flow control;
 - d) control by the Hayes AT command set;
 - e) autocalling, ITU-T Recommendation V.25 [28] auto answering and an auto logon feature;
 - f) ITU-T Recommendation V.42 [32] error correction and ITU-T Recommendation V.42bis [33] data compression;
- NOTE: ITU-T Recommendations V.25 [28] and V.42 [32] are optional extras for a modem interface.
- g) PSTN (GSTN) working implies using a PSTN interface cable terminating in a plug which meets national connection requirements given in EN 300 001 [2]. The compliance to this interface implies the need for the product to be subjected to type approval by the National regulatory body.

9.3 Integrated modem

The internal modem shall meet the same requirements as the external modem as specified in A.1.1 with the exception of providing the 9 pin interface connector as specified in A.1.1.1.a).

Annex A (informative): Basic characteristics of GSM

A.1 GSM - general

The GSM (Global System for Mobile Communications) standards can be operated in several frequency bands, e.g. 900 MHz, 1 800 MHz, and has reached world-wide success. The GSM network is realized as a network of contiguous cells, providing a complete coverage of the service area. Each cell has a Base Transceiver Station (BTS) operating on a dedicated set of radio channels. BTSs are logically grouped together and controlled by a Base Station Controller (BSC). A group of BSCs is served by a Mobile services Switching Center (MSC). The GSM system uses TDMA and GMSK modulation on 200 kHz wide carriers which results in a gross data rate of 270 kbit/s. This capacity is split in 8 full or 16 half rate channels and some signalling channels.

GSM is a digital cellular radio network containing standardized services as speech, fax and data. Some of the GSM data services that can be used in the DAB context is presented below. A GSM network does not have to offer all the specified data services, so described data services may not be implemented in all GSM networks.

GSM teleservices offer an end-to-end communication capability, including terminal equipment functions. GSM bearer services operate at OSI layer 1-3 between access points, serving as a base for teleservices (not the teleservice SMS) or user specific communication protocols. GSM offers secure data transfer within the GSM network, due to subscriber authentication and data enciphering.

GSM specifies a teleservice called, SMS (Short Message Service). The short message MT/PP (Mobile Terminated/Point to Point) and short message MO/PP (Mobile Originated/Point to Point) services can be used to transmit text messages with a maximum length of 160 characters (SMS messages longer than 160 characters are specified and is achieved by a concatenation procedure) between a mobile station and an SMS Service Centre (SMS-SC). An SMS-SC operates as a store and forward relay for messages and can be accessed via different sources.

GSM specifies several bearer services. Bearer services are circuit switched and data rates up to 9,6 kbit/s are today supported. A non-transparent bearer service uses ARQ (Automatic Retransmission Request) and has, therefore an error rate of effectively zero, but a variable delay.

A GSM Network can interwork with other GSM Networks, PSTN (Public Switched Telephone Network), ISDN (Integrated Services Digital Network) and PSPDN (Packet Switched Public Data Network).

A.2 Future GSM data services

The GSM phase 1 and phase 2 data services, as those presented in B.1, are introduced in most networks. GSM is still evolving, where ETSI is standardizing GSM phase 2+ services.

One of the phase 2+ services are packet data in GSM with speeds up to around 100 kbit/s. For packet data the General Packet Radio Service (GPRS) has been standardized.

The General Packet Radio Service (GPRS) standardization is in its final stages.

A high-speed circuit-switched data (HSCSD) service formed by combining several traffic channels has also been standardized.

Annex B (informative): Interworking types

When two dissimilar networks are required to interwork in order to support a communication between two subscribers, one on each network, a number of interworking functions (MSC/IWFs) are required to support the communication.

Service interworking is required when the Teleservices at the calling and called terminals are different. No service interworking has been identified as a requirement of GSM system for the purpose of this specification. However, network interworking is required whenever a GSM network and a non-GSM network together are involved to provide an end to end connection.

The concept of bearer services was developed for the ISDN and has been extended to the GSM. A bearer service is described as a type of telecommunication service that provides the capability for the transmission of signals between user-network interfaces.

Bearer services are described by a number of attributes, where an attribute is defined as a specified characteristic of an object or element whose values distinguish that object or element from others. Refer to ETS 300 501 [9] for complete list of bearer services, and ETS 300 557 [11] for coding of bearer capabilities.

Table B.1

Bearer service category in GSM network	Bearer Service in GSM	Bearer Service in ISDN	Service in PSTN
Circuit mode unstructured with unrestricted digital capability.	Asynchronous Data 300 bit/s		
	Asynchronous Data 1,2 kbit/s		
	Asynchronous Data 1 200/75 bit/s	Cct mode structured 64 kbit/s	Not Applicable
	Asynchronous Data 2,4 kbit/s	unrestricted	
Transparent and Non transparent	Asynchronous Data 4,8 kbit/s		
	Asynchronous Data 9,6 kbit/s		
3,1 kHz Audio Ex PLMN	Asynchronous Data 300 bit/s		
	Asynchronous Data 1,2 kbit/s		
Transparent and Non transparent	Asynchronous Data 1 200/75 bit/s	Cct mode	Cct mode
	Asynchronous Data 2,4 kbit/s	3,1 kHz Audio	3,1 kHz Audio
	Asynchronous Data 4,8 kbit/s		
	Asynchronous Data 9,6 kbit/s		

It is necessary to consider separately each type of interworking (i.e. GSM-ISDN and GSM-PSTN) since, in the worst case, "PSTN" could refer to an essentially analogue network without common-channel signalling.

B.1 Interworking to PSTN

For interworking of data calls between GSM and a PSTN a modem will be utilized to provide the interworking function.

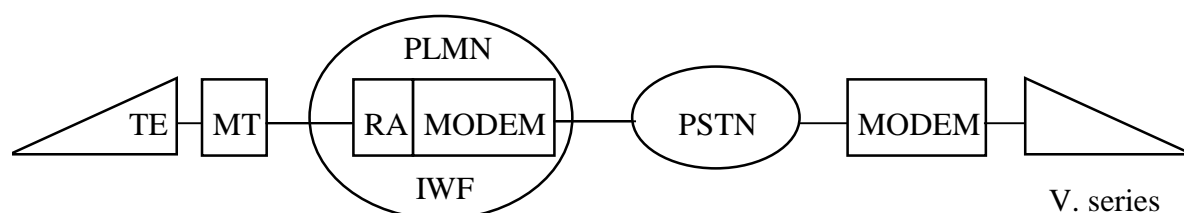

Figure B.1: PLMN PSTN interworking for circuit switched calls

The interworking function will need to negotiate with the user to establish the appropriate modem selection e.g. data rate, modulation scheme, etc. In addition, it will also be required to convert the signalling format, from a combination of out of band and in band, to that suitable for controlling the modem and the autocalling line procedure function where applicable. In the following modem selection procedures it is assumed that the interworking function and modems will be associated with each MSC.

For a data call originated by a circuit mode data terminal on the GSM network, the modem selection is done by using the element "modem type" in the call set-up message (bearer capability).

In addition, other elements of the call set-up will indicate the user rate, etc. to be used via that modem. The use of this information however means that the network is only able to select a modem from the modem pool which conforms to the speed which the terminal is utilizing at the DTE/DCE interface at the mobile station (e.g. CCITT Recommendation V.22 [25] for 1 200 bps). The exception to this is where the user has selected the non transparent service in which case either an autobauding or multi self selecting speed modem (e.g. ITU-T Recommendation V.32 [29]) may be used.

B.2 Interworking to ISDN

Low layer compatibility checking of the mobile originated call is carried out by the MSC/IWF to determine the appropriate bearer service selection in the ISDN. This will entail the MSC/IWF in mapping appropriately the GSM BC-IE (Bearer Capability Information Element) to the ISDN BC-IE. If it is not possible for the MSC/IWF to provide a bearer service match, then the MSC/IWF shall fail the call and indicate the reason to the user.

The MS shall provide further compatibility information (LLC/HLC-IEs) if required for defining end-to-end compatibility.

Where the bearer capability information indicates that the call is a circuit switched unrestricted digital call, then the MSC/IWF shall select the appropriate rate adapted ISDN bearer service.

The selection of the MSC/IWF will be by means of the bearer capability information within the call set up message. The mobile subscriber shall be able to select the unrestricted digital capability, which the MSC/IWF will map to the same capability in the ISDN call set up message. If an interworking point is encountered within the ISDN which does not support this service request, then a cause failure message indicating network unable to support service requested will be returned to the GSM network which will then pass this to the mobile subscriber. This will be used at the MS to clear the call. It will then be possible for the mobile subscriber to initiate a new call request this time indicating the transfer capability "3,1 kHz Ex GSM" plus other attributes such as user rate, modem type, etc.

Annex C (informative): Basic characteristics of DECT

C.1 DECT introduction

DECT, the European standard for cordless communication, is a general radio access technology that can be used by many different applications to connect to different telecommunication networks. It offers both telephony and data communication services to users within the coverage area. The system is based on a micro-cellular concept that provides low-power radio access between portable parts and DECT fixed parts at ranges up to a few kilometres. DECT equipment is commercially available.

The basic technical characteristics of DECT are as follows:

Frequency band	1 880 MHz – 1 900 MHz (extended frequency band is under investigation)
Carriers	10 × 1,728 MHz
Carrier multiplex	TDMA (Time Division Multiple Access), 24 full slots per frame (which can form 12 duplex channels)
Peak transmit power	250 mW
Modulation	GFSK (Gaussian Frequency Shift Keying), BT (Bandwidth Time product) = 0,5
Frame length	10 ms
Basic duplexing	TDD (Time Division Duplex) using two slots on the same carrier
Gross bit rate	1 152 kbit/s per carrier
Net bit rates	8 kbit/s B-field (traffic) per half slot (unprotected mode) 6,4 kbit/s B-field (traffic) per half slot (protected mode) 32 kbit/s B-field (traffic) per full slot (unprotected mode) 25,6 kbit/s B-field (traffic) per full slot (protected mode) 80 kbit/s B-field (traffic) per double slot (unprotected mode) 64 kbit/s B-field (traffic) per double slot (protected mode) 6,4 kbit/s A-field (control/signalling) per half slot, slot and double slot

DECT has features that could be suitable in an interactive DAB system. It can handle a lot of users in a small area (urban and suburban situation) and support a broad range of services. DECT has algorithms for authentication of both the base station and the terminal as well as a simple encryption scheme (DAM card support). A Wireless Relay Station (WRS) can be used to extend the coverage. There is no need for traditional frequency planning as DECT uses dynamic channel selection.

In the rest of this appendix, more information is provided concerning the main functionalities of the DECT standard.

C.2 The DECT standard

The structure of the basic DECT standard, ETS 300 175-1 [34] to ETS 300 175-9 [34], is based on the layered principles used in the ISO Open Systems Interconnection (OSI) model. The complete DECT Common Interface (CI) corresponds to the lower 3 layers of the ISO OSI model, but DECT defines 4 layers of protocol. These lower layers differ from the OSI model because the OSI model takes no account of either the uncertainties introduced by using radio transmissions at the physical layer or of the concept of handover. A structure of four layers is used for the signalling protocols as shown in figure C.1.

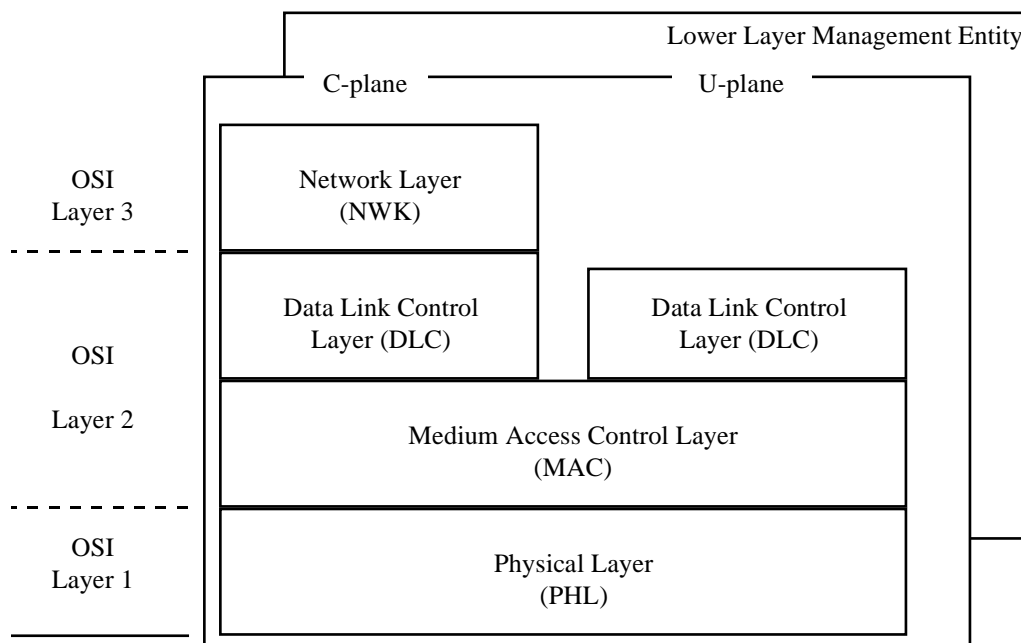

Figure C.1: The DECT layered structure

The top of the NWK layer corresponds to the top of the OSI layer 3. The intermediate boundaries have no OSI equivalent but for ease of understanding an approximate correspondence is given below:

- OSI Layer 1: all of the PHL layer plus part of MAC layer;
- OSI Layer 2: most of MAC layer plus all of DLC;
- OSI Layer 3: all of the NWK layer.

C.2.1 Physical (PHL) layer

The physical layer divides the radio spectrum into the physical channels. This division occurs in two fixed dimensions, frequency and time. The frequency and time division uses Time Division Multiple Access (TDMA) operation on multiple RF carriers. Ten carriers are provided in the frequency band 1 880 MHz to 1 900 MHz. DECT also provides for possible extensions of the band to meet future demand. On each carrier the TDMA structure defines 24 time slots (when full slots are used) in a 10 ms frame, where each timeslot may be used to transmit one self contained packet of data, see figure C.2. Each transmitted packet contains a synchronization field, together with control information, service information and error control.

Each FP radio end point operates according to a local timing reference and the PHL is the responsible for transmitting packets of data under direct control of the MAC layer. Adjacent FPs may be synchronized. This provides some advantages, particularly in high traffic situations.

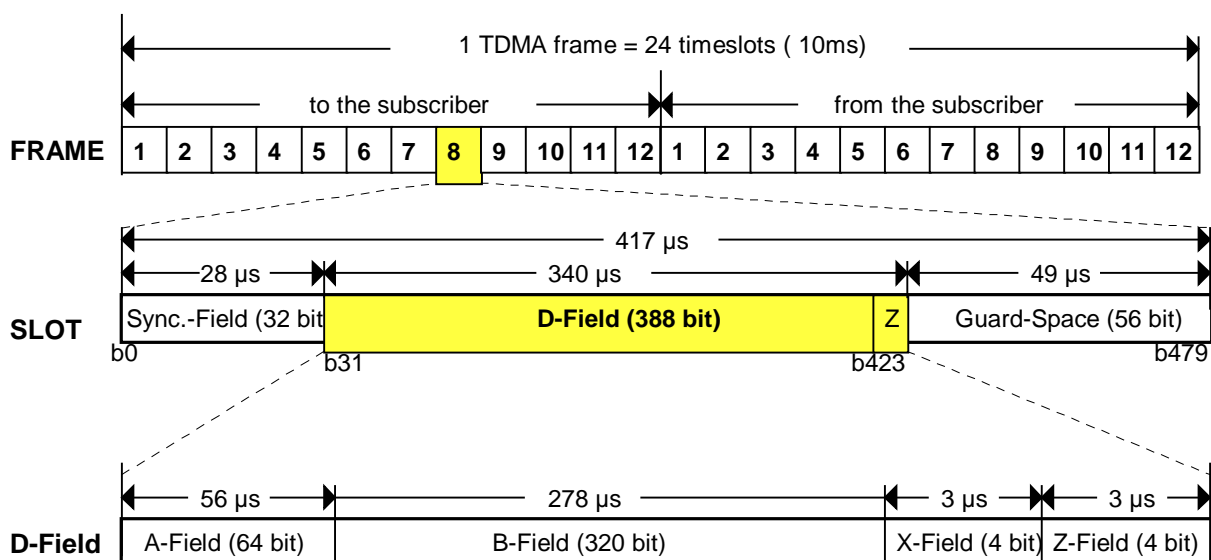

Figure C.2: Example of the full slot framing structure

C.2.2 Medium Access Control (MAC) layer

The MAC layer performs two main functions. Firstly, it selects physical channels, and then establishes and releases connections on those channels. Secondly, it multiplexes (and demultiplexes) control information, together with higher layer information and error control information, into slot-sized packets.

These functions are used to provide three independent services; a broadcast service, a connection oriented service and a connectionless service.

The broadcast service is a special DECT feature: it multiplexes a range of broadcast information into a reserved field (the A-field), and this field appears as part of all active transmissions. The broadcast service is always transmitted in every cell (even in the absence of user traffic) on at least one physical channel. These "beacon" transmissions allow PPs to quickly identify all FPs that are within range, to select one, and to lock to it without requiring any portable transmissions.

C.2.3 Data Link Control (DLC) layer

The DLC layer is concerned with the provision of very reliable data links to the NWK layer. Many of the imperfections of the radio transmissions are already removed by the efforts of the MAC layer, and the DLC layer is designed to work closely with the MAC layer to provide higher levels of data integrity than can be provided by the MAC layer alone.

The DECT layered model separates into two planes of operation at the DLC layer; the C-plane and the U-plane. The C-plane is common to all applications, and provides very reliable links for the transmission of internal control signalling and limited quantities of user information traffic. Full error control is provided with a balanced Link Access Protocol (LAPC). The U-plane provides a family of alternative services, where each service is optimized to the particular need of a specific type of services. The simplest service is the transparent unprotected service used for speech transmission. Other services support circuit mode and packet mode data transmission, with varying levels of protection.

C.2.4 Network (NWK) layer

The (NWK) layer is the main signalling layer of the protocol. It adopts a similar style to the ISDN layer 3 protocol and offers a similar level of functions. The NWK layer operates using an exchange of messages between peer entities. The basic set of messages supports the establishment, maintenance and release of calls. Additional messages support a range of extended capabilities.

The basic Call Control (CC) provides a circuit switched service selected from one of the range of DLC options. Other network layer services are Supplementary Services (SS), Connection oriented Message Service (COMS),

ConnectionLess Message Service (CLMS) and Mobility Management (MM). These services are arranged as independent entities, and a particular application can be realized using more than one.

The MM is a particularly important group of services. This group contains the procedures that support the special cordless mobility of PPs, for example authentication and location registration.

C.2.5 Lower Layer Management Entity (LLME)

The LLME contains defined procedures that concern more than one layer. Most of these procedures have only local significance, and they are defined in general terms to allow for alternative implementations. The location of some selected LLME procedures is as follows:

- MAC layer: creation, maintenance and release of bearers, by activating and deactivating pairs of physical channels; physical channel management, including the choice of free physical channels and the assessment of the quality of received signals;
- DLC layer: connection management, which includes the establishment and release of connections in response to NWK layer demands; routing of C-plane and U-plane data to suitable connections;
- NWK layer: service negotiation and mapping.

C.2.6 Interworking Units (IWU)

Transport of the information to the end user requires additional layers of protocol. In general, an IWU will be required to provide the necessary interworking functions. This IWU plays a important role in defining the exact service that is provided, e.g. when interconnecting to other networks as the PSTN or the ISDN.

C.3 Profiles

The basic DECT standard defines the operation of the DECT air interface and is very general. To achieve interoperability for specific applications, different profiles have been defined or are in progress of being defined, e.g. the Generic Access Profile (GAP), the DECT/ISDN interworking profiles, the DECT data services profiles, the DECT/GSM (Global System for Mobile Communication) interworking profile and the DECT radio in the local loop access profile.

A DECT profile standard is a chosen subset of the DECT CI standard for a specific application. It includes all requirements for interoperability for equipment from different manufacturers. If the CI standard has some ambiguity or lacks some provision, this is clarified or added in the profile standard. All defined features are process mandatory. This means that if a feature is used, it is used in a specified manner. Whether the provision of a feature is mandatory or optional is stated separately for FPs and PPs.

C.3.1 The Radio in the local loop Access Profile (RAP)

Radio in the local loop, RLL, is also defined in the DECT standard. The Radio in the local loop Access Profile, RAP, is standardized in two parts, ETS 300 765-1 [20] and ETS 300 765-2 [21]. The first part handles PSTN, analogue leased lines and 64 kbit/s bearer service. It also provides for optional mobility features by supporting GAP PP subscriber terminals and CTAs with WRS GAP functionality. For documents relating to RLL (basic telephony via PSTN), see figure C.3.

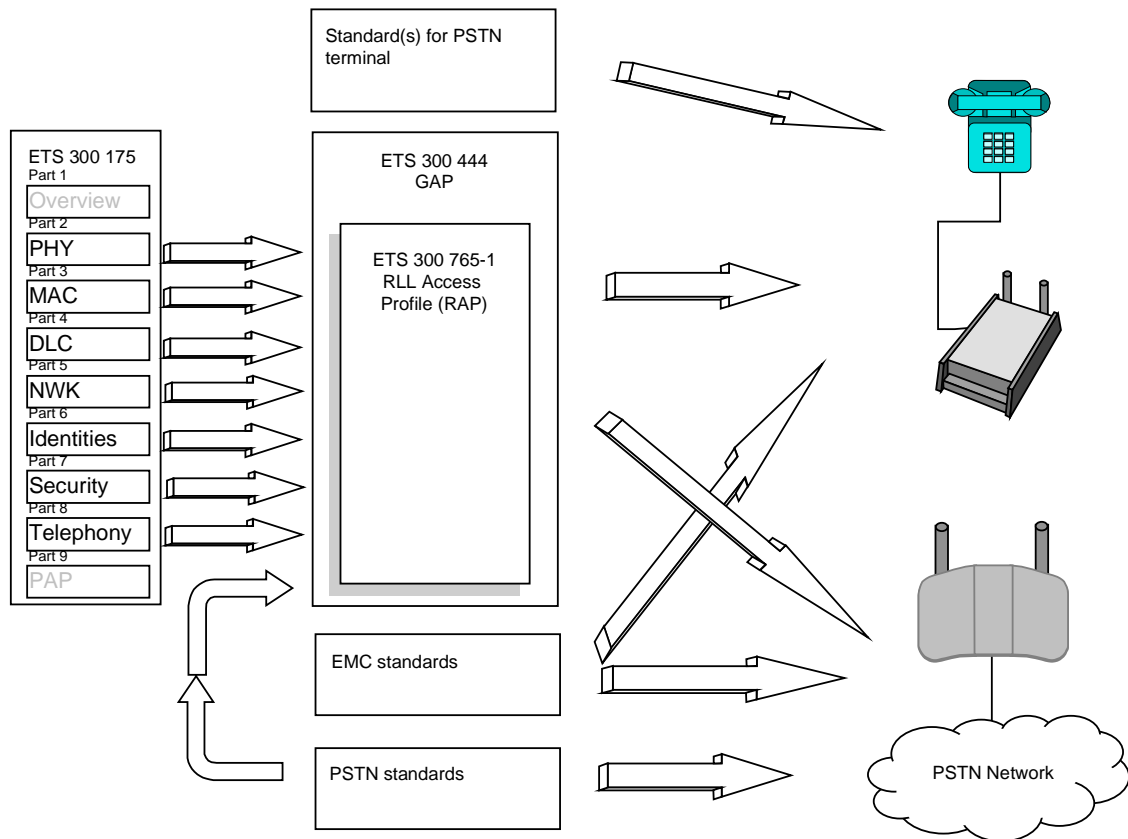

Figure C.3: Documents relating to RLL (basic telephony via PSTN)

The second part contains telecommunication services as offered by ISDN, contemporary non-voiceband data services provided through for example a dedicated data port at the CTA, and support of digital leased lines. The provision of the mentioned services is not mandated by the second part of the standard, but if they are provided they shall be provided as defined. For documents relating to RLL (advanced telephony), see figure C.4.

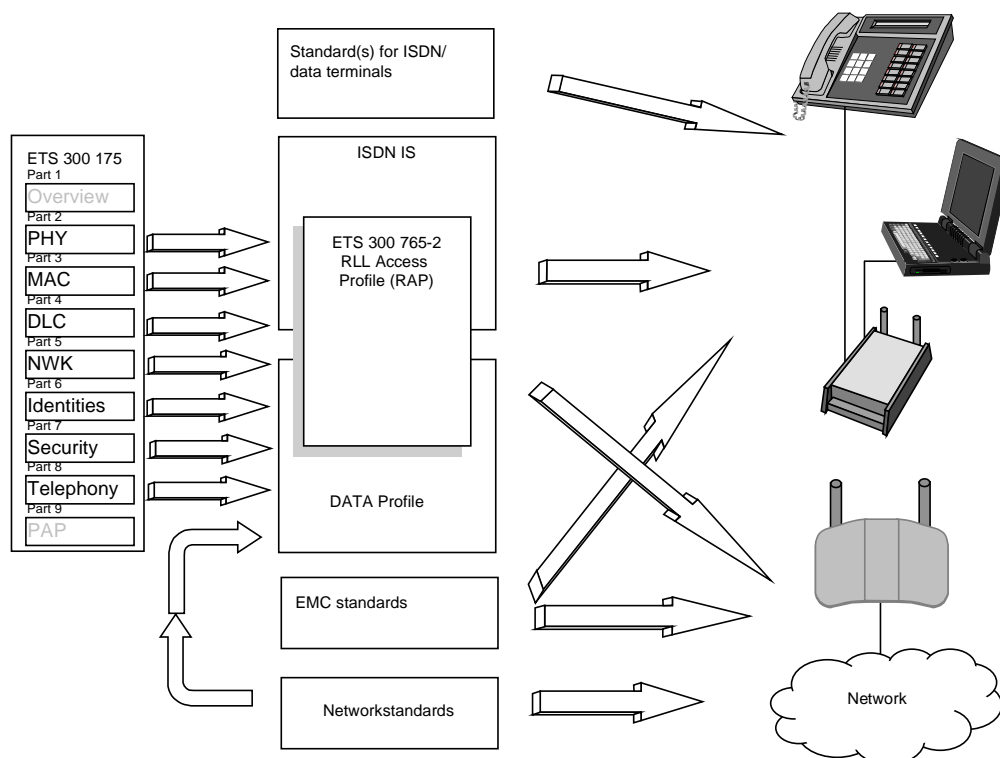

Figure C.4: Documents relating to RLL (advanced telephony).

An objective is to use as much as possible for the RLL from existing profiles: the GAP profile EN 300 444 [3], DECT-ISDN Intermediate System as defined in DE/RES-03039 [35] and the data profiles, e.g. A/B.2 as defined in ETS 300 701 [19] and C.2 as defined in ETS 300 651 [17]. Therefore most of the RAP features refer to features defined in other profiles and only the necessary additional features are listed and explained in the RAP document.

The DECT RLL services are examined in detail in ETR 308 [23]. This report identifies the basic wired analogue PSTN services that could be replaced by an RLL system, and also identifies that there are market opportunities for much more advanced services than are possible with today's standard telephones.

C.3.2 The Data Services Profiles (DSP's)

The DECT standard includes data services. The services and relationships of the different profiles are described in ETR 185 [22]. The data services profiles (DSP's) are a family of profiles which build upon and extend each other, aimed at the general connection of terminals supporting non-voice services to a fixed infrastructure, private and public. The application decides which type to use, due to parameters such as data rate, latency, reliability and power consumption. They all exploit the powerful lower-layer data services of DECT, which are specifically oriented towards LAN, multimedia and serial data capability, but each member of the profile family has been optimized for a different kind of user service. The DSP's are divided into six service types and two mobility classes.

- Type A: Low speed frame relay, with a net sustainable throughput of up to 24 kbit/s, optimized for bursty data, low power consumption and low complexity applications such as handportable equipment.
- Type B: High performance frame relay, with a net sustainable throughput of up to 552 kbit/s asymmetrically or 288 kbit/s symmetrically, optimized for high speed and low latency with bursty data. Equipment implementing the type B profile shall inter-operate with type A equipment.
- Type C: Non-transparent connection of data streams requiring Link Access Protocol (LAP) services, optimized for high reliability and low additional complexity. Type C builds upon the services offered by the type A/B profiles. Provision for a packet assembly/disassembly function for asynchronous data streams is also included.

- Type D: Transparent and isochronous connection of synchronous data streams optimized for interworking applications requiring continuous data streams.
- Type E: A short message transfer or paging service which may be unacknowledged or acknowledged.
- Type F: An application profile specifically supporting teleservices, such as fax building upon the services offered by the type A/B and C profiles.
- Class 1: Local area applications with pre-registered terminals.
- Class 2: Roaming applications, both public and private.

C.3.3 The PPP interworking DSP

The ETSI DECT project did in June 1997 approve a DSP for Point-to-Point Protocol (PPP) interworking ETS 300 556 [10] for public enquiry, which builds upon ETS 300 651 [17] and ETS 300 701 [19].

The reasons for the choice of the PPP interworking DSP EN 301 240 [4] for DAB applications are that it offers interworking to PPP, which the DAB network independent protocols Eureka Project 147 [36] makes use of, and a reliable and effective handling of data traffic over the air interface. The PPP interworking DSP and Eureka Project 147 [36] make references to the PPP specifications. This means that there is a harmonized overlap, but the PPP specifications should only be implemented once. A reliable and effective handling of data traffic is important for DAB applications and results from the fact that the PPP interworking DSP builds upon the C.2 profile (type C, mobility class 2).

The PPP interworking DSP specifies an interworking profile for non-voice equipment with roaming mobility, providing Point-to-Point Protocol (PPP) transmission to allow dial-up internet access and general multi-protocol datagram transport. PPP packet transfers on the DECT air interface are specified via a high efficient DECT packet transmission protocol. However, interworking to the fixed network may be via a number of interface protocols, including X.25, Frame Relay, ATM, and traditional circuit switched voice band modem and ISDN connection.

The profile is intended for roaming applications and so specifies mobility class 2. It thus specifies the requirements on the Network layer Call Control and Mobility Management entities to provide full public services. This profile defines the specific requirements on the Physical (PHL), Medium Access Control (MAC), Data Link Control (DLC) and Network (NWK) layers of DECT. The standard also specifies Management Entity (ME) requirements and generic interworking conventions which ensure the efficient use of the DECT spectrum.

C.4 Wireless Relay Station

A Wireless Relay Station (WRS) is a special DECT unit, that combines elements of both PPs and FPs, that is capable of intelligently relaying DECT radio transmissions to extend the coverage area ETS 300 700 [18]. A PP do not distinguish between a WRS and a FP.

C.5 DECT Authentication module (DAM)

Access rights and other subscription related information can be loaded into a PP over the air, via a connector, or by inserting a chip card. To use a DAM card, a PP has to be provided with the DAM interface.

The DECT Authentication module is a chip card that can be programmed with DECT identities and inserted into a DECT PP with an appropriate DAM card interface. It provides one method by which a DECT system operator can load user identities, access rights information, security parameters authentication and cipher keys into a PP.

A DAM card can be used in conjunction with different profiles, i.e. it is not restricted to any particular application.

The DAM card is compatible with the corresponding card in GSM (the SIM card).

Bibliography

The following material, though not specifically referenced in the body of the present document (or not publicly available), gives supporting information.

- 91/263/EEC (1991): "Council Directive on the approximation of the laws of the Member States concerning telecommunications terminal equipment, including the mutual recognition of their conformity".
- ETS 300 011: "Integrated Services Digital Network (ISDN); Primary rate user-network interface Layer 1 specification and test principles".
- ETS 300 500: "Digital cellular telecommunications system (Phase 2); Principles of telecommunication services supported by a GSM Public Land Mobile Network (PLMN) (GSM 02.01)".
- ETS 300 505: "Digital cellular telecommunications system (Phase 2); Mobile Station (MS) features (GSM 02.07 version 4.8.2)".
- ETS 300 522: "Digital cellular telecommunications system (Phase 2); Network architecture (GSM 03.02)".
- ETS 300 528: "European digital cellular telecommunications system (Phase 2); GSM Public Land Mobile Network (PLMN) connection types (GSM 03.10)".
- ETS 300 550: "European digital cellular telecommunications system (Phase 2); Mobile Station - Base Station System (MS - BSS) interface; General aspects and principles (GSM 04.01)".
- ETS 300 551: "European digital cellular telecommunications system (Phase 2); GSM Public Land Mobile Network (PLMN) access reference configuration (GSM 04.02)".
- ETS 300 552: "European digital cellular telecommunications system (Phase 2); Mobile Station - Base Station System (MS - BSS) interface; Channel structures and access capabilities (GSM 04.03)".
- ETS 300 554: "European digital cellular telecommunications system (Phase 2); Data Link (DL) layer; General aspects (GSM 04.05)".
- ETS 300 555: "European digital cellular telecommunications system (Phase 2); Mobile Station - Base Station System (MS - BSS) interface; Data Link (DL) layer specification (GSM 04.06)".
- ETS 300 562: "European digital cellular telecommunications system (Phase 2); Rate adaption on the Mobile Station - Base Station System (MS - BSS) interface (GSM 04.21)".
- ETR 111: "Digital cellular telecommunications system (Phase 2); Interworking between Phase 1 infrastructure and Phase 2 Mobile Stations (MS) (GSM 09.90 version 4.9.0)".
- DAVIC 1.0 Specification. DAVIC System Reference Model.

History

Document history			
V1.1.1	January 2000	Membership Approval Procedure	MV 200011: 2000-01-18 to 2000-03-17