



**Electromagnetic compatibility
and Radio spectrum Matters (ERM);
Additional ElectroMagnetic Compatibility (EMC)
requirements and resistibility requirements for
telecommunications equipment for enhanced availability of
service in specific applications**

Reference

RES/ERM-EMC-317

Keywords

EMC, management, network, power supply,
switching, testing, transmission

ETSI

650 Route des Lucioles
F-06921 Sophia Antipolis Cedex - FRANCE

Tel.: +33 4 92 94 42 00 Fax: +33 4 93 65 47 16

Siret N° 348 623 562 00017 - NAF 742 C
Association à but non lucratif enregistrée à la
Sous-Préfecture de Grasse (06) N° 7803/88

Important notice

Individual copies of the present document can be downloaded from:

<http://www.etsi.org>

The present document may be made available in more than one electronic version or in print. In any case of existing or perceived difference in contents between such versions, the reference version is the Portable Document Format (PDF). In case of dispute, the reference shall be the printing on ETSI printers of the PDF version kept on a specific network drive within ETSI Secretariat.

Users of the present document should be aware that the document may be subject to revision or change of status. Information on the current status of this and other ETSI documents is available at

<http://portal.etsi.org/tb/status/status.asp>

If you find errors in the present document, please send your comment to one of the following services:

http://portal.etsi.org/chaicor/ETSI_support.asp

Copyright Notification

No part may be reproduced except as authorized by written permission.
The copyright and the foregoing restriction extend to reproduction in all media.

© European Telecommunications Standards Institute 2014.
All rights reserved.

DECT™, PLUGTESTS™, UMTS™ and the ETSI logo are Trade Marks of ETSI registered for the benefit of its Members.
3GPP™ and LTE™ are Trade Marks of ETSI registered for the benefit of its Members and
of the 3GPP Organizational Partners.
GSM® and the GSM logo are Trade Marks registered and owned by the GSM Association.

Contents

Intellectual Property Rights	5
Foreword.....	5
Introduction	5
1 Scope	6
2 References	6
2.1 Normative references	6
2.2 Informative references.....	7
3 Definitions and abbreviations.....	8
3.1 Definitions.....	8
3.2 Abbreviations	9
4 General operational conditions.....	10
4.1 Equipment configuration.....	10
4.2 Exercising equipment.....	10
4.3 Laboratory environment	10
5 General performance criteria for immunity tests.....	10
5.1 Performance criterion A	11
5.2 Performance criterion B	11
5.3 Performance criterion C	11
6 Immunity: test methods	11
6.1 General	11
6.2 Electrostatic discharge.....	11
6.3 Electrical fast transients/burst.....	11
6.4 Surges	12
6.4.1 Outdoor signal line ports.....	12
6.4.2 Indoor signal line ports	12
6.4.3 AC power line ports	12
6.5 Immunity to continuous conducted signals	12
6.5.1 AC power supply port.....	12
6.5.2 DC power supply interface port.....	12
6.5.3 Signal line port.....	12
6.6 Immunity to radiated electromagnetic fields	13
6.7 Immunity to power supply disturbances: AC and DC ports	13
6.7.1 Test of immunity to low frequency disturbances: AC ports	13
6.7.2 Test of immunity to low frequency disturbances: DC ports	13
6.8 Immunity to interference from permanent power induction.....	13
6.9 Power frequency magnetic fields	13
7 Resistibility: test methods	13
7.1 Electrostatic discharge.....	13
7.2 Lightning	13
7.3 Power induction and earth potential rise	13
7.4 Mains power contact	13
8 Emission: test methods and limits	14
9 Immunity requirements	14
9.1 Equipment operating in telecommunication centres.....	15
9.1.1 Telecommunication centres, level 1.....	15
9.1.1.1 Telecommunication centres, enclosure port, level 1	15
9.1.1.2 Telecommunication centres, ports for outdoor signal lines, level 1	15
9.1.1.3 Telecommunication centres, ports for indoor signal lines, level 1	15
9.1.1.4 Telecommunication centres, AC power ports, level 1	16
9.1.1.5 Telecommunication centres, DC power ports, level 1	16

9.1.2	Telecommunication centres, level 2.....	16
9.1.2.1	Telecommunication centres, enclosure port, level 2	16
9.1.2.2	Telecommunication centres, ports for outdoor signal lines, level 2	17
9.1.2.3	Telecommunication centres, ports for indoor signal lines, level 2	17
9.1.2.4	Telecommunication centres, AC power ports, level 2	18
9.1.2.5	Telecommunication centres, DC power ports, level 2	18
9.2	Equipment operating in locations other than telecommunication centres	18
9.2.1	Equipment operating in locations other than telecommunication centres, level 1	18
9.2.1.1	Other than telecommunication centres, enclosure port, level 1	18
9.2.1.2	Other than telecommunication centres, ports for outdoor signal lines, level 1	19
9.2.1.3	Other than telecommunication centres, ports for indoor signal lines, level 1	19
9.2.1.4	Other than telecommunication centres, AC power ports, level 1	19
9.2.1.5	Other than telecommunication centres, DC power ports, level 1	19
9.2.2	Equipment operating in locations other than telecommunication centres, level 2	20
9.2.2.1	Other than telecommunication centres, enclosure port, level 2.....	20
9.2.2.2	Other than telecommunication centres, ports for outdoor signal lines, level 2	21
9.2.2.3	Other than telecommunication centres, ports for indoor signal lines, level 2	21
9.2.2.4	Other than telecommunication centres, AC power ports, level 2	22
9.2.2.5	Other than telecommunication centres, DC power ports, level 2	22
10	Resistibility requirements.....	23
Annex A (normative):	Surges: test method for ports of signal lines remaining within the building	24
A.1	Test set-up for ports with ISDN interface	24
Annex B (informative):	Evaluation of test results	26
Annex C (informative):	Guidance for the product specific operational conditions and performance criteria.....	28
C.1	General	28
C.2	Operational conditions and performance criteria during EMC tests	28
C.2.1	General considerations	28
C.2.2	Operational conditions during EMC tests	29
C.2.3	Performance criteria during EMC tests	29
C.2.4	Examples of specific performance criteria	30
C.2.5	Example of additional performance criteria (and further details of requirements) for "primary rate multiple access" equipment	30
Annex D (informative):	Bibliography.....	31
History		32

Intellectual Property Rights

IPRs essential or potentially essential to the present document may have been declared to ETSI. The information pertaining to these essential IPRs, if any, is publicly available for **ETSI members and non-members**, and can be found in ETSI SR 000 314: "*Intellectual Property Rights (IPRs); Essential, or potentially Essential, IPRs notified to ETSI in respect of ETSI standards*", which is available from the ETSI Secretariat. Latest updates are available on the ETSI Web server (<http://ipr.etsi.org>).

Pursuant to the ETSI IPR Policy, no investigation, including IPR searches, has been carried out by ETSI. No guarantee can be given as to the existence of other IPRs not referenced in ETSI SR 000 314 (or the updates on the ETSI Web server) which are, or may be, or may become, essential to the present document.

Foreword

This final draft ETSI Standard (ES) has been produced by ETSI Technical Committee Electromagnetic compatibility and Radio spectrum Matters (ERM), and is now submitted for the ETSI standards Membership Approval Procedure.

The present document defines the EMC requirements of telecommunication network equipment for an increased reliability and the resistibility requirements.

Introduction

The present document defines additional EMC requirements for telecommunications equipment where higher performance is required by operators to guarantee enhanced availability of service in specific applications. Resistibility requirements are also defined with reference to ITU-T K series recommendations.

The environments considered in the present document are defined in TR 101 651 [i.5] and are:

- telecommunication centres (classes 1 and 2 of TR 101 651 [i.5]);
- locations other than telecommunication centres (classes 3 and 4 of TR 101 651 [i.5]).

Considering that all kinds of equipment are not equally important, two equipment categories and associated EMC requirements are introduced and are designated as:

- level 1 (see tables in clauses 9.1.1.1 to 9.1.1.5 and 9.2.1.1 to 9.2.1.5);
- level 2 (see tables in clauses 9.1.2.1 to 9.1.2.5 and 9.2.2.1 to 9.2.2.5);

the latter containing the more demanding requirements.

The appropriate level should be chosen by the operator considering the consequences of failure of the equipment which may lead to impaired function, loss of service, failure to meet contractual obligations or bad publicity and loss of reputation.

1 Scope

The present document defines additional EMC requirements for telecommunications network equipment where higher performance is required to guarantee enhanced availability of service in specific applications.

It covers the emission, immunity and resistibility requirements of the equipment.

The present document is applicable to all equipment types, examples of which are listed below:

- switching equipment which includes trunk and local telephone exchanges, remote switching concentrators, international switches, telex switches and network packet switches;
- transmission equipment which includes multiplexers, line equipment and repeaters, Synchronous Digital Hierarchy (SDH), Digital Cross Connect (DXC), Asynchronous Transfer Mode (ATM) and network terminations;
- power supply equipment which includes central power plant, end of suite power supplies, power management systems and other dedicated telecommunications network power supplies;
- supervisory equipment and dedicated Operation And Maintenance (OAM) equipment;
- tariff and billing equipment.

2 References

References are either specific (identified by date of publication and/or edition number or version number) or non-specific. For specific references, only the cited version applies. For non-specific references, the latest version of the referenced document (including any amendments) applies.

Referenced documents which are not found to be publicly available in the expected location might be found at <http://docbox.etsi.org/Reference>.

NOTE: While any hyperlinks included in this clause were valid at the time of publication, ETSI cannot guarantee their long term validity.

2.1 Normative references

The following referenced documents are necessary for the application of the present document.

- [1] ETSI EN 300 386 (V1.6.1) (2012): "Electromagnetic compatibility and Radio spectrum Matters (ERM); Telecommunication network equipment; ElectroMagnetic Compatibility (EMC) requirements".
- [2] CENELEC EN 61000-4-2:2009: "Electromagnetic compatibility (EMC); Part 4-2: Testing and measurement techniques - Electrostatic discharge immunity test".
- [3] CENELEC EN 61000-4-3 (2006 + Amendment 1: 2008 + Amendment 2: 2010 + Interpretation Sheet: 2009): "Electromagnetic compatibility (EMC); Part 4-3: Testing and measurement techniques - Radiated, radio-frequency, electromagnetic field immunity test".

NOTE 1: Amendment 1: 2008 is available at:

http://www.cenelec.eu/dyn/www/f?p=104:110:3933184816656335:::FSP_ORG_ID,FSP_LANG_ID,FSP_PROJECT:814,25,20990

NOTE 2: Amendment 2: 2010 is available at:

http://www.cenelec.eu/dyn/www/f?p=104:110:3933184816656335:::FSP_ORG_ID,FSP_LANG_ID,FSP_PROJECT:814,25,20991

NOTE 3: Interpretation Sheet: 2009 is available at:

http://www.cenelec.eu/dyn/www/?p=104:110:3933184816656335:::FSP_ORG_ID.FSP_LANG_ID.FSP_PROJECT:814,25,21894

- [4] CENELEC EN 61000-4-4:2012: "Electromagnetic compatibility (EMC); Part 4-4: Testing and measurement techniques - Electrical fast transient/burst immunity test".
- [5] CENELEC EN 61000-4-5:2006: "Electromagnetic compatibility (EMC); Part 4-5: Testing and measurement techniques - Surge immunity test".
- [6] CENELEC EN 61000-4-6:2009: "Electromagnetic compatibility (EMC); Part 4-6: Testing and measurement techniques - Immunity to conducted disturbances, induced by radio-frequency fields".
- [7] CENELEC EN 61000-4-8:2010: "Electromagnetic compatibility (EMC); Part 4-8: Testing and measurement techniques - Power frequency magnetic field immunity test".
- [8] CENELEC EN 61000-4-11:2004: "Electromagnetic compatibility (EMC); Part 4-11: Testing and measurement techniques - Voltage dips, short interruptions and voltage variations immunity tests".
- [9] Recommendation ITU-T K.54 (12-2004): "Conducted immunity test method and level at fundamental power frequencies".
- [10] Recommendation ITU-T K.20 (11-2011): "Resistibility of telecommunication equipment installed in a telecommunications centre to overvoltages and overcurrents".
- [11] Recommendation ITU-T K.21 (11-2011): "Resistibility of telecommunication equipment installed in customer premises to overvoltages and overcurrents".
- [12] Recommendation ITU-T K.45 (11-2011): "Resistibility of telecommunication equipment installed in the access and trunk networks to overvoltages and overcurrents".

2.2 Informative references

The following referenced documents are not necessary for the application of the present document but they assist the user with regard to a particular subject area.

- [i.1] Recommendation ITU-T K.44 (05-2012): "Resistibility tests for telecommunication equipment exposed to overvoltages and overcurrents - Basic Recommendation".
- [i.2] ETSI ETS 300 132-1 (09-1996): "Equipment Engineering (EE); Power supply interface at the input to telecommunications equipment; Part 1: Operated by alternating current (ac) derived from direct current (dc) sources".
- [i.3] ETSI EN 300 132-2 (V2.4.6) (2011): "Environmental Engineering (EE); Power supply interface at the input to telecommunications and datacom (ICT) equipment; Part 2: Operated by -48 V direct current (dc)".
- [i.4] IEC 60050-161 (1990): "International Electrotechnical Vocabulary; Chapter 161: Electromagnetic compatibility".
- [i.5] ETSI TR 101 651 (1999): "Electromagnetic compatibility and Radio spectrum Matters (ERM); Classification of the electromagnetic environment conditions for equipment in telecommunication networks".

3 Definitions and abbreviations

3.1 Definitions

For the purposes of the present document, the terms and definitions given in IEC 60050-161 [i.4] and the following apply:

Audio (low) Frequency (AF): frequency interval from 0 Hz to 20 kHz

NOTE: It may sometimes be convenient to extend the use of this term to include the range of frequencies up to 150 kHz.

burst (161-02-07): sequence of a limited number of distinct pulses or an oscillation of limited duration

characteristic severity: characteristic severity for a certain detail parameter in an environmental class states a severity which has only a low probability (generally less than 1 %) of being exceeded

NOTE: The term relates to duration, rate of occurrence or location. It applies to requirements on the environment and to immunity requirements.

continuous disturbance (161-02-11): electromagnetic disturbance the effects of which on a particular device or equipment cannot be resolved into a succession of distinct effects

discontinuous interference (161-02-13): electromagnetic interference occurring during certain time intervals separated by interference-free intervals

duration (of a voltage change) (161-08-03): interval of time for the voltage to increase or decrease from the initial value to the final value

duration (of a pulse): interval of time between the instants at which the instantaneous value of a pulse reaches 50 % of the pulse magnitude for the first and last time

environment, environmental conditions: electromagnetic conditions external to the equipment, to which it is subjected at a certain time

NOTE: The environmental conditions comprise a combination of single environmental parameters and their severities.

environmental class: representation of the environment on locations with similar properties

NOTE: They are specified and standardized to provide an operational frame of reference for:

- requirements on the environment;
- immunity requirements.

The class is described using an envelope of environmental conditions expressed in terms of a number of environmental parameters and their characteristic severities or other characteristics. The environmental parameters specified for the class are limited to those which may affect equipment performance.

environmental parameters: present one or more properties of the electromagnetic environment

immunity (to a disturbance) (161-01-20): ability of a device, equipment or system to perform without degradation in the presence of an electromagnetic disturbance

impulsive disturbance (161-02-09): electromagnetic disturbance which, when incident on a particular device or equipment, manifests itself as a succession of distinct pulses or transients

level: measures on a relative scale how important it is that the equipment operates as specified

NOTE: Two levels are defined for the purpose of the present document and are designated as level 1 and level 2.

Level 1 should be selected if the equipment has moderate failure consequences. An equipment has moderate failure consequences when:

- a failure causes limited inconvenience;
- repairs may be made without compromising the responsibilities of the network operator.

Level 2 should be selected if the equipment has severe failure consequences. An equipment has severe failure consequences when:

- failure compromises the function of vital, centralized systems, or services of commercially sensitive or security related nature;
- repair or restoration costs are high, or the time the equipment is out of service is unacceptably long;
- corruption of charging or billing information occurs.

The following definitions apply only in the context of the present document, except where the reference to IEC 60050-161 [i.4] is given adjacent to the clause title, in parentheses.

pulse (161-02-02): abrupt variation of short duration of a physical quantity followed by a rapid return to the initial value

Radio Frequencies (RF): frequency range above 150 kHz

rise time (of a pulse) (161-02-05): interval of time between the instants at which the instantaneous value of a pulse first reaches a specified lower value and then a specified upper value

NOTE: Unless otherwise specified, the lower and upper values are fixed at 10 % and 90 % of the pulse magnitude.

shielding effectiveness: for a given external source, the ratio of electric or magnetic field strength at a point before and after the placement of the shield in question

surge (voltage) (161-08-11): transient voltage wave propagating along a line or a circuit and characterized by a rapid increase followed by a slower decrease of the voltage

telecommunication network: network operated under a licence granted by a national telecommunications authority, which provides telecommunications between Network Termination Points (NTPs) (i.e. excluding terminal equipment beyond the NTPs)

transient (adjective or noun) (161-02-01): pertaining to or designating a phenomenon or a quantity which varies between two consecutive steady states during a time interval which is short compared with the timescale of interest

3.2 Abbreviations

For the purposes of the present document, the following abbreviations apply:

AC	Alternating Current
AM	Amplitude Modulation
ATM	Asynchronous Transfer Mode
CDN	Coupling Decoupling Network
CRC	Cyclic Redundancy Check
CRT	Cathode Ray Tube
DC	Direct Current
DXC	Digital Cross Connect
EMC	ElectroMagnetic Compatibility
ESD	ElectroStatic Discharge
EUT	Equipment Under Test
ISDN	Integrated Services Digital Network
LAN	Local Area Network
NTP	Network Termination Point
OAM	Operation And Maintenance
PS	Power Supply
RF	Radio Frequency
SDH	Synchronous Digital Hierarchy
TE	Telecommunication Equipment

4 General operational conditions

This clause gives the general operational conditions. The product-specific operating conditions will be derived from the product description and documentation and stated in the test report.

The general operational conditions shall allow for appropriate measuring of the emission and for testing of immunity.

The tests described shall be performed with the Equipment Under Test (EUT) powered up, (i.e. connected to an appropriate power supply), and operating in a manner which is as representative of normal operation as possible.

Details on the evaluation of test results are given in annex B.

4.1 Equipment configuration

Power and signal distribution, grounding, interconnecting cabling and physical placement of equipment of a test system shall simulate the typical application and usage in so far as is practicable, and shall be in accordance with the relevant product specifications.

The configuration that tends to maximize the EUT's emission or minimize its immunity is not usually intuitively obvious and in most instances selection will involve some trial and error testing. For example, interface cables may be moved or equipment re-orientated during initial stages of testing and the effects on the results observed.

Only configurations within the range of positions likely to occur in normal use need to be considered.

The configuration selected shall be fully detailed and documented in the test report, together with the justification for selecting that particular configuration.

4.2 Exercising equipment

The exercising equipment and other auxiliary equipment shall be sufficiently decoupled from the EUT so that the performance of such equipment does not significantly influence the test results.

4.3 Laboratory environment

For all the tests, the test laboratory environment shall be the one defined in the corresponding basic standards.

The electromagnetic environment of the test laboratory shall not influence the results.

The laboratory environment shall not exceed the limits specified by the manufacturer for normal operation of the EUT.

5 General performance criteria for immunity tests

In this clause, general performance criteria are defined and equipment shall meet these criteria when tested according to the requirements of clause 8.

The manufacturer has the obligation to express the specific performance criteria in terms which relate to the normal performance of his specific product when used as intended according to the product description and documentation.

Interpretation of compliance

The equipment is deemed to comply with the EMC requirements if:

- it meets the test levels given in tables in clauses 9.1.1.1 to 9.2.2.5;
- it meets the performance criteria according to tables in clauses 9.1.1.1 to 9.2.2.5;
- it is operated according to the general and product specific operating conditions, given in clause 4 and in the product documentation;

- the performance items, as derived from the product documentation, being monitored.

5.1 Performance criterion A

The equipment shall continue to operate as intended without operator intervention. No degradation of performance or loss of function is allowed below a performance level specified by the manufacturer when the apparatus is used as intended. The performance level may be replaced by a permissible loss of performance. If the minimum performance level or the permissible performance loss is not specified by the manufacturer, then either of these may be derived from the product description and documentation, and by what the user may reasonably expect from the equipment if used as intended.

5.2 Performance criterion B

After the test, the equipment shall continue to operate as intended without operator intervention. No degradation of performance or loss of function is allowed, after the application of the phenomena, below a performance level specified by the manufacturer, when the equipment is used as intended. The performance level may be replaced by a permissible loss of performance.

During the test, degradation of performance is allowed. However, no change of operating state or stored data is allowed to persist after the test. For the parameters that can be monitored during transient phenomena, the degradation of these parameters, if any, shall be stated in the test report.

If the minimum performance level (or the permissible performance loss) is not specified by the manufacturer, then either of these may be derived from the product description and documentation, and what the user may reasonably expect from the apparatus if used as intended.

5.3 Performance criterion C

Loss of function is allowed, provided the function is self-recoverable, or can be restored by the operation of the controls by the user (the network operator or the subsequent retry by the subscriber) in accordance with the manufacturer's instructions. For equipment installed in unattended locations, user operation of controls is not allowed.

Functions, and/or information stored in non-volatile memory, or protected by a battery backup, shall not be lost.

6 Immunity: test methods

6.1 General

Where reference is made in the present document to specific "test levels" to be used for the tests, it is implicitly required that the EUT shall also fulfil the compliance criteria when tested at "test levels" lower than those specified. This requirement does not apply, however, to tests for immunity to continuous phenomena.

6.2 Electrostatic discharge

The test method and laboratory conditions are described in EN 61000-4-2 [2].

6.3 Electrical fast transients/burst

The test method to be used is described in EN 61000-4-4 [4].

6.4 Surges

6.4.1 Outdoor signal line ports

The immunity test method to be used for signal line ports is described in EN 61000-4-5 [5].

When normal operation cannot be achieved because of the impact of CDN on the EUT, the performance criterion has to be surveyed on the neighbouring lines. In this case the test generator shall be connected via the coupling network to one signal port. This port shall only be connected to the surge generator. During the test, the EUT and all ports (other than the one connected to the generator) shall comply with the given compliance criteria. After the surge has been applied the generator shall be disconnected from the port and the port checked against the performance criteria.

6.4.2 Indoor signal line ports

Ports of signal lines remaining within the building shall not be subjected to the method in clause 6.4.1. Annex A specifies an appropriate test method, dedicated to unshielded 4-wire balanced interface types with phantom DC power feeding and operating at bit rates up to and including 2 Mbit/s. This test method shall apply when the coupling/decoupling network specified in the EN 61000-4-5 [5] is not suitable for the bit rate of the signal port under test. The test set up for shielded interface cables is specified in EN 61000-4-5 [5].

For ports connected to multi-conductor lines, for which the network according to annex A is not applicable, the networks coupling methods defined in the EN 61000-4-5 [5] shall be used.

Signal lines, which according to the manufacturer's specification, shall not be longer than 10 m, shall not be subjected to this test.

6.4.3 AC power line ports

The test method to be used for AC power line ports is described in EN 61000-4-5 [5].

6.5 Immunity to continuous conducted signals

6.5.1 AC power supply port

The test method to be used is described in EN 61000-4-6 [6].

Power cables, which according to the manufacturer's specification shall not be longer than 3 m, shall not be subjected to these tests.

6.5.2 DC power supply interface port

The test method to be used is described in EN 61000-4-6 [6].

Power cables, which according to the manufacturer's specification shall not be longer than 3 m, shall not be subjected to these tests.

The coupling/decoupling network type M1 (see EN 61000-4-6 [6]) shall be used when the DC return lead at the EUT side is to be connected to the equipment protective earth. If the DC return lead is not connected to the equipment protective earth then the coupling/decoupling network M2 shall be used.

6.5.3 Signal line port

The test method to be used is described in EN 61000-4-6 [6].

Signal cables, which according to the manufacturer's specification shall not be longer than 3 m, shall not be subjected to these tests.

6.6 Immunity to radiated electromagnetic fields

The test method to be used is described in EN 61000-4-3 [3].

6.7 Immunity to power supply disturbances: AC and DC ports

6.7.1 Test of immunity to low frequency disturbances: AC ports

Immunity to low frequency disturbances on the AC line ports, test methods are defined below.

Telecommunication equipment in telecommunication centres:

- these phenomena are addressed in ETS 300 132-1 [i.2].

Telecommunication equipment, locations other than telecommunication centres:

- the test method to be used is described in EN 61000-4-11 [8].

6.7.2 Test of immunity to low frequency disturbances: DC ports

Immunity to low frequency disturbances on the DC line ports, test methods are defined below.

Telecommunication equipment in telecommunication centres:

- these phenomena are addressed in EN 300 132-2 [i.3].

6.8 Immunity to interference from permanent power induction

The test method to be used is described by Recommendation ITU-T K.54 [9].

6.9 Power frequency magnetic fields

The test method to be used is described in EN 61000-4-8 [7].

7 Resistibility: test methods

7.1 Electrostatic discharge

The test method and laboratory conditions are described in EN 61000-4-2 [2].

7.2 Lightning

The test method and laboratory conditions are described in Recommendation ITU-T K.44 [i.1].

7.3 Power induction and earth potential rise

The test method and laboratory conditions are described in Recommendation ITU-T K.44 [i.1].

7.4 Mains power contact

The test method and laboratory conditions are described in Recommendation ITU-T K.44 [i.1].

8 Emission: test methods and limits

The equipment shall meet the emission requirements given in EN 300 386 [1].

9 Immunity requirements

Tables in clauses 9.1.1.1 to 9.2.2.5 shall be used in the process of selection of appropriate tests to be applied to the EUT.

Tables in clauses 9.1.1.1 to 9.1.1.5 shall be used for equipment which is intended to be installed in telecommunication centres, level 1.

Tables in clauses 9.1.2.1 to 9.1.2.5 shall be used for equipment which is intended to be installed in telecommunication centres, level 2.

Tables in clauses 9.2.1.1 to 9.2.1.5 shall be used for equipment which is intended to be installed in locations other than telecommunication centres, level 1.

Tables in clauses 9.2.2.1 to 9.2.2.5 shall be used for equipment which is intended to be installed in locations other than telecommunication centres, level 2.

Test levels have been selected from the recommended levels defined in the relevant basic standards and using the environmental conditions as described in the TR 101 651 [i.5].

The test specifications for equipment in telecommunication centres cover environmental classes 1 and 2.

The test specifications for equipment in locations other than telecommunication centres cover environmental classes 3 and 4.

Test levels have been selected taking into account:

- that different installation sites can have different environmental conditions;
- that environmental characteristic severity levels may be exceeded with a finite probability;
- that the required safety margin shall reflect the equipment failure consequences.

NOTE: In case that a certain equipment type may be installed in several, different environments, it is recommended that test levels are selected such that the more severe conditions are covered.

9.1 Equipment operating in telecommunication centres

9.1.1 Telecommunication centres, level 1

9.1.1.1 Telecommunication centres, enclosure port, level 1

The equipment shall meet the requirements given in clause 7.2.1.1 of EN 300 386 [1], together with the following requirements:

	Environmental phenomenon	Unit	Test level and characteristic	Reference	Performance criterion	Remarks
Immunity						
9.1.1.1.1	Power-frequency magnetic field	Hz A/m (r.m.s.)	50 3	EN 61000-4-8 [7]	A	(notes 1 and 2)
NOTE 1: Applicable only to equipment containing devices susceptible to magnetic fields, such as CRT monitors, Hall elements, electrodynamic microphones, magnetic field sensors, etc.						
NOTE 2: For CRTs the acceptable jitter depends upon the character size and is computed for a test level of 1 A/m as follows:						
$\text{Jitter (mm)} = \frac{(3 \times \text{character height in mm} + 1)}{40}$						
As jitter is linearly proportional to the magnetic field strength tests can be carried out at other test levels extrapolating the maximum jitter level appropriately.						

9.1.1.2 Telecommunication centres, ports for outdoor signal lines, level 1

The equipment shall meet the requirements given in clause 7.2.1.2 of EN 300 386 [1], together with the following requirements:

	Environmental phenomenon	Unit	Test level and characteristic	Reference	Performance criterion	Remarks
Immunity						
9.1.1.2.1	Permanent power induction	V min Hz	60 15 50/16 ² / ₃	Recommendation ITU-T K.54 [9]	A	Only applies to ports for unscreened pair cables longer than 500 m.

9.1.1.3 Telecommunication centres, ports for indoor signal lines, level 1

The equipment shall meet the requirements given in clause 7.2.1.3 of EN 300 386 [1].

9.1.1.4 Telecommunication centres, AC power ports, level 1

The equipment shall meet the requirements given in clause 7.2.1.4 of EN 300 386 [1].

9.1.1.5 Telecommunication centres, DC power ports, level 1

The equipment shall meet the requirements given in clause 7.2.1.5 of EN 300 386 [1].

9.1.2 Telecommunication centres, level 2

9.1.2.1 Telecommunication centres, enclosure port, level 2

	Environmental phenomenon	Unit	Test level and characteristic	Reference	Performance criterion	Remarks
Immunity						
9.1.2.1.1	Electrostatic discharge (ESD)	kV kV	6 Contact Discharge 8 Air Discharge	EN 61000-4-2 [2]	B	
9.1.2.1.2	Radio frequency electromagnetic field amplitude modulated	MHz V/m % AM (1 kHz)	80 to 1 000 10 (note 1) 80	EN 61000-4-3 [3]	A	
		MHz V/m % AM (1 kHz)	1 400 to 2 700 10 80	EN 61000-4-3 [3]	A	
9.1.2.1.3	Power-frequency magnetic field	Hz A/m (r.m.s.)	50 3	EN 61000-4-8 [7]	A	(notes 2 and 3)
NOTE 1: Except for the ITU-T broadcast frequency band: 87 MHz to 108 MHz, 174 MHz to 230 MHz, 470 MHz to 790 MHz, where the test level shall be 3 V/m.						
NOTE 2: Applicable only to equipment containing devices susceptible to magnetic fields, such as CRT monitors, Hall elements, electrodynamic microphones, magnetic field sensors, etc.						
NOTE 3: For CRTs the acceptable jitter depends upon the character size and is computed for a test level of 1 A/m as follows:						
$\text{Jitter (mm)} = \frac{(3 \times \text{character height in mm} + 1)}{40}$						
As jitter is linearly proportional to the magnetic field strength tests can be carried out at other test levels extrapolating the maximum jitter level appropriately.						

9.1.2.2 Telecommunication centres, ports for outdoor signal lines, level 2

	Environmental phenomenon	Unit	Test level and characteristic	Reference	Performance criterion	Remarks
Immunity						
9.1.2.2.1	Fast transients	kV T_r/T_h ns Rep. frequency kHz	1 5/50 5	EN 61000-4-4 [4]	B	
9.1.2.2.2	Surges Line to Ground Line to Line	T_r/T_h μ s kV kV	10/700 (5/320) 1 0,5	EN 61000-4-5 [5]	B	Line to Line test only applies to unshielded cables
9.1.2.2.3	Radio frequency, conducted continuous	MHz V % AM (1 kHz) Source impedance Ω	0,15 to 80 10 (see note 2) 80 150	EN 61000-4-6 [6]	A	
9.1.2.2.4	Permanent power induction	V min Hz	60 15 $50/16^{2/3}$	Recommendation ITU-T K.54 [9]	A	Only applies to ports for unshielded pair cables longer than 500 m.
NOTE 1: Outdoor lines carrying DC power with superimposed signals shall be treated as outdoor signal lines.						
NOTE 2: Except for the ITU-T broadcast frequency band: 47 MHz to 68 MHz where the test level shall be 3 V.						

9.1.2.3 Telecommunication centres, ports for indoor signal lines, level 2

Only ports connected to inter-system cables are to be tested. Testing of ports for intra-system cabling, e.g. local alarm and control, (provided in all cases both ends are controlled by the same manufacturer) is left to the discretion of the manufacturer which is responsible for the correct installation of the cables.

	Environmental phenomenon	Unit	Test level and characteristic	Reference	Performance criterion	Remarks
Immunity						
9.1.2.3.1	Fast transients	kV T_r/T_h ns Rep. frequency kHz	1 5/50 5	EN 61000-4-4 [4]	B	Only applies when cables longer than 3 m are intended to be connected.
9.1.2.3.2	Surges Line to ground	T_r/T_h μ s kV	1,2/50 (8/20) 0,5	EN 61000-4-5 [5] and clause 6.4.2 of the present document	B	Only applies when cables longer than 10 m are connected.
9.1.2.3.3	Radio frequency, conducted continuous	MHz V % AM (1 kHz) Source impedance Ω	0,15 to 80 10 (see note 2) 80 150	EN 61000-4-6 [6]	A	Only applies when cables longer than 3 m are connected.
NOTE 1: Indoor lines carrying DC power with superimposed signals shall be treated as indoor signal lines.						
NOTE 2: Except for the ITU-T broadcast frequency band: 47 MHz to 68 MHz where the test level shall be 3 V.						

9.1.2.4 Telecommunication centres, AC power ports, level 2

	Environmental phenomenon	Unit	Test level and characteristic	Reference	Performance criterion	Remarks
Immunity						
9.1.2.4.1	Fast transients	kV T_r/T_h ns Rep. frequency kHz	2 5/50 5	EN 61000-4-4 [4]	B	
9.1.2.4.2	Surges line to line line to ground	T_r/T_h μ s kV kV	1,2/50 (8/20) 1 2	EN 61000-4-5 [5]	B B	
9.1.2.4.3	Radio frequency, conducted continuous	MHz V % AM (1 kHz) Source impedance Ω	0,15 to 80 10 (see note) 80 150	EN 61000-4-6 [6]	A	
NOTE: Except for the ITU-T broadcast frequency band: 47 MHz to 68 MHz where the test level shall be 3 V.						

9.1.2.5 Telecommunication centres, DC power ports, level 2

	Environmental phenomenon	Unit	Test level and characteristic	Reference	Performance criterion	Remarks
Immunity						
9.1.2.5.1	Fast transients	kV T_r/T_h ns Rep. frequency kHz	1 5/50 5	EN 61000-4-4 [4]	B	Only applies when cables longer than 3 m are connected.
9.1.2.5.2	Radio frequency, conducted continuous	MHz V % AM (1 kHz) Source impedance Ω	0,15 to 80 10 (see note) 80 150	EN 61000-4-6 [6]	A	Only applies when cables longer than 3 m are connected.
NOTE: Except for the ITU-T broadcast frequency band: 47 MHz to 68 MHz where the test level shall be 3 V.						

9.2 Equipment operating in locations other than telecommunication centres

9.2.1 Equipment operating in locations other than telecommunication centres, level 1

9.2.1.1 Other than telecommunication centres, enclosure port, level 1

The equipment shall meet the requirements given in clause 7.2.2.1 of EN 300 386 [1], together with the following requirements.

	Environmental phenomenon	Unit	Test level and characteristic	Reference	Performance criterion	Remarks
Immunity						
9.2.1.1.3	Power-frequency magnetic field	Hz A/m (r.m.s.)	50 3	EN 61000-4-8 [7]	A	(notes 1 and 2)
NOTE 1: Applicable only to equipment containing devices susceptible to magnetic fields, such as CRT monitors, Hall elements, electrodynamic microphones, magnetic field sensors, etc.						
NOTE 2: For CRTs the acceptable jitter depends upon the character size and is computed for a test level of 1 A/m as follows:						
$\text{Jitter (mm)} = \frac{(3 \times \text{character height in mm} + 1)}{40}$						
As jitter is linearly proportional to the magnetic field strength tests can be carried out at other test levels extrapolating the maximum jitter level appropriately.						

9.2.1.2 Other than telecommunication centres, ports for outdoor signal lines, level 1

The equipment shall meet the requirements given in clause 7.2.2.2 of EN 300 386 [1], together with the following tests:

	Environmental phenomenon	Unit	Test level and characteristic	Reference	Performance criterion	Remarks
Immunity						
9.2.1.2.4	Permanent power induction	V min Hz	60 15 $50/16^{2/3}$	Recommendation ITU-T K.54 [9]	A	Only applies to ports for unshielded pair cables longer than 500 m.

9.2.1.3 Other than telecommunication centres, ports for indoor signal lines, level 1

The equipment shall meet the requirements given in clause 7.2.2.3 of EN 300 386 [1].

9.2.1.4 Other than telecommunication centres, AC power ports, level 1

The equipment shall meet the requirements given in clause 7.2.2.4 of EN 300 386 [1].

9.2.1.5 Other than telecommunication centres, DC power ports, level 1

The equipment shall meet the requirements given in clause 7.2.2.5 of EN 300 386 [1].

9.2.2 Equipment operating in locations other than telecommunication centres, level 2

9.2.2.1 Other than telecommunication centres, enclosure port, level 2

	Environmental phenomenon	Unit	Test level and characteristic	Reference	Performance criterion	Remarks
Immunity						
9.2.2.1.1	Electrostatic discharge	kV kV	8 contact discharge 15 air discharge	EN 61000-4-2 [2]	B	It is not necessary to perform this test for contact discharges with levels below the given resistibility limits. Lower levels than the given limits apply for air discharge only.
9.2.2.1.2	Radio frequency electromagnetic field amplitude modulated	MHz V/m % AM (1 kHz)	80 to 1 000 10 80	EN 61000-4-3 [3]	A	
		MHz V/m % AM (1 kHz)	1 400 to 2 700 10 80	EN 61000-4-3 [3]	A	
9.2.2.1.3	Power-frequency magnetic field	Hz A/m (r.m.s.)	50 3	EN 61000-4-8 [7]	A	(notes 1 and 2)
NOTE 1: Applicable only to equipment containing devices susceptible to magnetic fields, such as CRT monitors, Hall elements, electrodynamic microphones, magnetic field sensors, etc.						
NOTE 2: For CRTs the acceptable jitter depends upon the character size and is computed for a test level of 1 A/m as follows:						
$\text{Jitter (mm)} = \frac{(3 \times \text{character height in mm} + 1)}{40}$						
As jitter is linearly proportional to the magnetic field strength tests can be carried out at other test levels extrapolating the maximum jitter level appropriately.						

9.2.2.2 Other than telecommunication centres, ports for outdoor signal lines, level 2

	Environmental phenomenon	Unit	Test level and characteristic	Reference	Performance criterion	Remarks
Immunity						
9.2.2.2.1	Fast transients	kV T_r/T_h ns Rep. frequency kHz	1 5/50 5	EN 61000-4-4 [4]	B	
9.2.2.2.2	Surges line to line line to ground	T_r/T_h μ s kV kV	10/700 (5/320) 1 2	EN 61000-4-5 [5]	B	Line to Line test only applies to unshielded cables
9.2.2.2.3	Radio frequency, conducted continuous	MHz V % AM (1 kHz) Source impedance Ω	0,15 to 80 10 80 150	EN 61000-4-6 [6]	A	
9.2.2.2.4	Permanent power induction	V min Hz	60 15 $50/16^{2/3}$	Recommendation ITU-T K.54 [9]	A	Only applies to ports for unshielded pair cables longer than 500 m.
NOTE: Outdoor lines carrying DC power with superimposed signals shall be treated as outdoor signal lines.						

9.2.2.3 Other than telecommunication centres, ports for indoor signal lines, level 2

Only ports connected to inter-system cables are to be tested. Testing of ports for intra-system cabling, e.g. local alarm and control, (provided in all cases both ends are controlled by the same manufacturer) is left to the discretion of the manufacturer which is responsible for the correct installation of the cables.

	Environmental phenomenon	Unit	Test level and characteristic	Reference	Performance criterion	Remarks
Immunity						
9.2.2.3.1	Fast transients	kV T_r/T_h ns Rep. frequency kHz	1 5/50 5	EN 61000-4-4 [4]	B	Only applies when cables longer than 3 m are intended to be connected.
9.2.2.3.2	Surges Line to ground	T_r/T_h μ s kV	1,2/50 (8/20) 0,5	EN 61000-4-5 [5], and clause 6.4.2 of the present document	B	Only applies when cables longer than 10 m are connected.
9.2.2.3.3	Radio frequency, conducted continuous	MHz V % AM (1 kHz) Source impedance Ω	0,15 to 80 10 80 150	EN 61000-4-6 [6]	A	Only applies when cables longer than 3 m are connected.

9.2.2.4 Other than telecommunication centres, AC power ports, level 2

	Environmental phenomenon	Unit	Test level and characteristic	Reference	Performance criterion	Remarks
Immunity						
9.2.2.4.1	Fast transients	kV T_r/T_h ns Rep. frequency kHz	2 5/50 5	EN 61000-4-4 [4]	B	
9.2.2.4.2	Surges (line to line) (line to ground)	T_r/T_h μ s kV kV	1,2/50 (8/20) 2 4	EN 61000-4-5 [5]	B B	
9.2.2.4.3	Radio frequency, conducted continuous	MHz V % AM (1 kHz) Source impedance Ω	0,15 to 80 10 80 150	EN 61000-4-6 [6]	A	
9.2.2.4.4	Voltage dips and short interruptions	% residual voltage cycle % residual voltage cycle % residual voltage cycle	0 1 70 25 0 250	EN 61000-4-11 [8]	B C C	voltage shift at zero crossing

9.2.2.5 Other than telecommunication centres, DC power ports, level 2

	Environmental phenomenon	Unit	Test level and characteristic	Reference	Performance criterion	Remarks
Immunity						
9.2.2.5.1	Fast transients	kV T_r/T_h ns Rep. frequency kHz	2 5/50 5	EN 61000-4-4 [4]	B	Only applies when cables longer than 3 m are connected.
9.2.2.5.2	Radio frequency, conducted continuous	MHz V % AM (1 kHz) Source impedance Ω	0,15 to 80 10 80 150	EN 61000-4-6 [6]	A	Only applies when cables longer than 3 m are connected.

10 Resistibility requirements

The equipment shall meet the resistibility requirements defined in the following product family recommendations:

- Recommendation ITU-T K.20 [10]: Resistibility of telecommunication equipment installed in a telecommunications centre to overvoltages and overcurrents.
- Recommendation ITU-T K.21 [11]: Resistibility of telecommunication equipment installed in customer's premises to overvoltages and overcurrents.
- Recommendation ITU-T K.45 [12]: Resistibility of telecommunication equipment installed in the access and trunk networks to overvoltages and overcurrents.

These requirements are not intended to be applied to Local Area Networks (LANs).

The basic resistibility requirements apply to all equipment. The enhanced resistibility requirements apply on the operator's request.

The resistibility requirements for telecommunication terminal equipment installed in customer premises are defined in Cenelec standards.

Annex A (normative): Surges: test method for ports of signal lines remaining within the building

Ports of signal lines remaining within the building, e.g. of ISDN-equipment with interfaces at basic and primary rate shall be tested with the surge test set-up as described in figure A.1.

An example of a coupling/decoupling network for an unshielded interface cable is described in figure A.2.

The test generator to produce the test pulses $1,2/50 \mu\text{s}$ shall conform to EN 61000-4-5 [5]. The total source impedance (generator plus external resistor) shall be 40Ω .

At least 5 positive and 5 negative pulses with alternating polarity shall be applied to the EUT. The time interval between two pulses shall be at least 10 s.

A.1 Test set-up for ports with ISDN interface

Figures A.1 and A.2 show the test set-up for ports with ISDN interface.

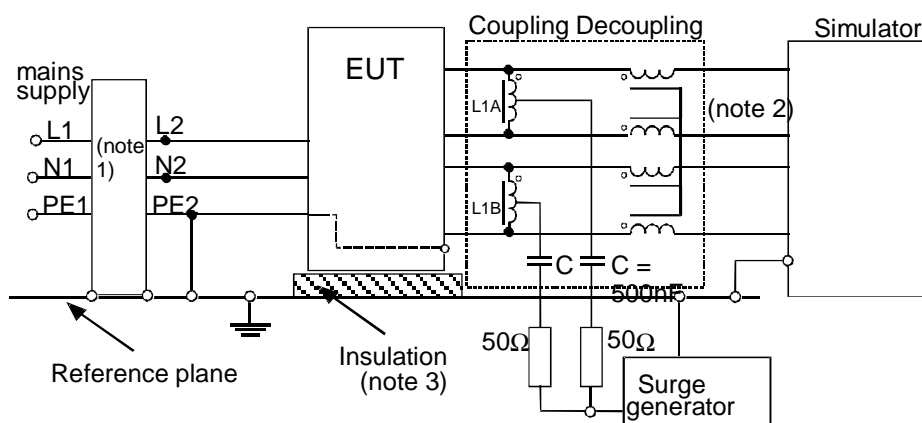

NOTE 1: The impedance matching network is used to decouple the mains and to provide low impedance to reference plane at EUT side. The impedance matching network is described in figure A.2.

NOTE 2: The coupling/decoupling network is described in figure A.3.

NOTE 3: Insulation thickness: 0,1 m for floor standing EUT; 0,5 mm for table top EUT.

NOTE 4: Interface wiring shall be placed 0,1 m above reference plane.

Figure A.1: Surge test set-up for basic rate and primary rate interface ports (using unshielded interface cable)

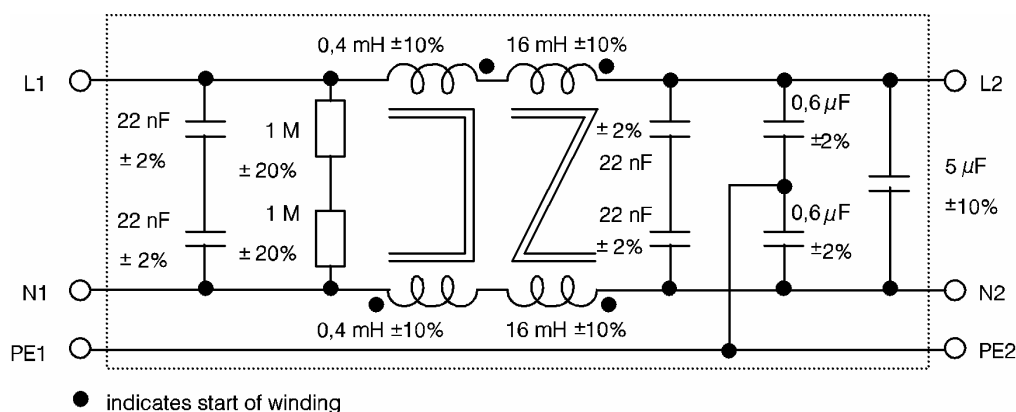

NOTE: The impedance matching network is required to protect the mains supply and the power source for remote power feeding from test overvoltages and to establish standard termination conditions for the test. It is used:

- to couple the EUT either to the ac mains or to the dc feeding source PS;
- to terminate the mains input with the low impedance port L2/N2, to standardize the presentation of the mains source;
- to feed the EUT from a high impedance port L1/N1 to allow for effective surge application at the feeding interface of the TE.

In conjunction with a coupling capacitance of 1 μF as incorporated in the coupling network figure A.3 (C.1), a nominal pulse form of 1,2/50 μs shall be influenced by the high impedance port L1/N1 of the impedance matching networks; figure A.3 (C.2), to a reduced time to half value of about 40 μs . For the nominal pulse form 10/700 μs the time to half value may be reduced to approximately 100 μs . This reduction is envisaged and in line with the statistics of overvoltages at mains socket-outlets.

Figure A.2: Impedance matching network

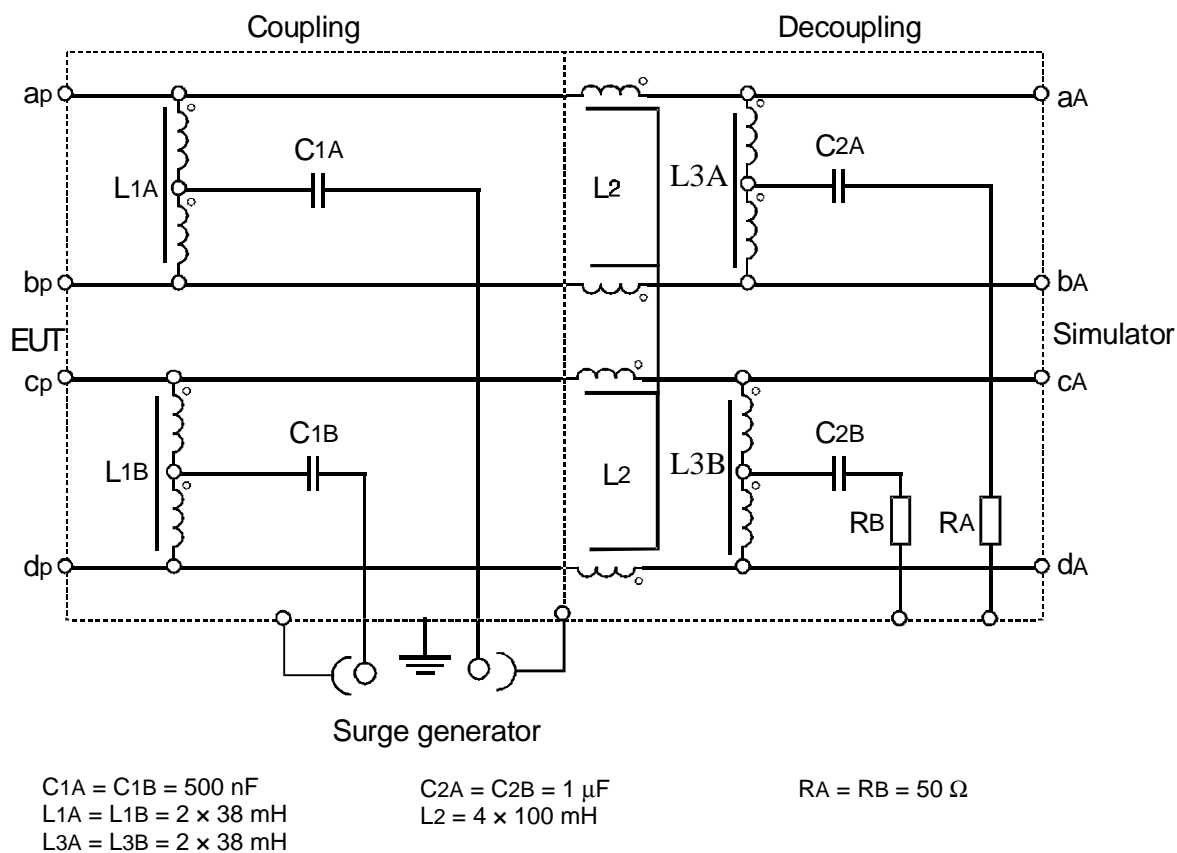

NOTE: L2 shall be a 4-coil current compensated choke to avoid saturation of coils due to phantom power feeding.

Figure A.3: Example of a coupling/decoupling network for two symmetrical pairs for surge testing

Annex B (informative): Evaluation of test results

The test report will comprise:

- a) a detailed description of the EUT, the physical aspects of the set-up and of the earthing conditions;
- b) a list (and description) of the auxiliary equipment;
- c) a detailed description of the operation modes and operational status of the EUT during emission testing;
- d) the response of the EUT to the immunity test levels should be expressed in terms of the compliance criteria detailed in clause 5 of the present document;
- e) a description of the test conditions (including temperature and relative humidity) and test results together with the method of test. If the method used differs from the preferred method, then the deviations should be recorded and justification made in the test report;
- f) a statement of measurement uncertainty;
- g) the calibration status of all test equipment used;
- h) if an unrepeatable response occurs, this should be noted in the test report, but the response should not be taken into account in the assessment of the EUT.

Test reports

The work carried out by the testing laboratory will be covered by a report which accurately, clearly and unambiguously presents the test results and all other relevant information.

Each test report should include at least the following information:

- a) name and address of testing laboratory and location where the test was carried out when different from the address of the testing laboratory;
- b) unique identification of report (such as serial number) and of each page, and total number of pages of the report;
- c) name and address of client;
- d) description and identification of the test item;
- e) date of receipt of test item and date(s) of performance of test;
- f) identification of the test specification or description of the method or procedure;
- g) description of sampling procedure, where relevant;
- h) any deviations, additions to or exclusions from the test specification, and any other information relevant to a specific test;
- i) identification of any non-standard test method or procedure utilized;
- j) measurements, examinations and derived results, supported by tables, graphs, sketches and photographs as appropriate, and any failures identified;
- k) a statement on measurement uncertainty (where relevant);
- l) a signature and title or an equivalent marking of person(s) accepting technical responsibility for the test report and date of issue;
- m) a statement to the effect that the test results relate only to the items tested;

- n) a statement that the report cannot be reproduced except in full without the written approval of the testing laboratory.

Particular care and attention needs to be paid to the arrangement of the test report, especially with regard to presentation of the test data and ease of assimilation by the reader. The format should be carefully and specifically designed for each type of test carried out, but the headings should be standardized as far as possible.

Corrections or additions to a test report after issue can be made only by a further document suitably marked, e.g. "Amendment/Addendum to test report serial number ... (or as otherwise identified)", and should meet the relevant requirements of the preceding paragraphs.

A test report should not include any advice or recommendation arising from the test results.

Test results should be presented accurately, clearly, completely and unambiguously in accordance with instructions that may be part of the test methods.

Quantitative results should be given together with calculated or estimated uncertainty.

Test results obtained on items which have been statistically selected from a larger lot, batch or production quantity are frequently used to infer the properties of the lot, batch or production quantity. Any extrapolation of the test results to the properties of the lot, batch or production quantity should be contained in a separate document.

NOTE: Test results could be measured values, findings from the visual examination or practical use of the test item, derived results or any other type of observation from the testing activities. Test results may be supported by tables, photographs or graphical information of any kind appropriately identified.

Annex C (informative): Guidance for the product specific operational conditions and performance criteria

C.1 General

Dedicated product EMC specifications should contain the following clauses:

- a) a "Scope" clause

"This EMC specification applies to <product definition>".

NOTE 1: The scope should define the product type and its main functions.

- b) a "level" clause

"The level for <product> is <1/2> due to the <main function> performed by <product>".

NOTE 2: For most equipment "level 1" applies. "Level 2" only applies in exceptional cases when equipment has severe failure consequences (see also clause 3).

EXAMPLE: Level 1 applies for high bit rate transmission equipment (2 Gbit/s) under normal circumstances.

- c) an "Installation environment" clause

"The <product> tested according to the present EMC specification is designed to be installed in <telecommunication centres/locations other than telecommunication centres>".

NOTE 3: If installed in a different environment than specified, a performance degradation cannot be excluded. If no restrictions are put on the installation environment the product needs to comply with both cases (telecommunication centre/other than telecommunication centre), implying that the more severe test level is to be used when the test is performed.

C.2 Operational conditions and performance criteria during EMC tests

C.2.1 General considerations

It should be observed that EMC immunity tests are time consuming and expensive to perform.

To illustrate this, one example is given: test of immunity to radiated RF fields involves a slow sweep through the total frequency range specified. This slow sweep (often realized by increasing the frequency in small increments) needs, in general, to be repeated eight times (2 antenna polarizations, 4 sides of the EUT facing the antenna) it is, therefore, preferred that the compliance criteria are defined such that:

- repetition of time consuming tests is avoided;
- they are rapidly verified;

and further, such that:

- transportable monitoring equipment can be used.

C.2.2 Operational conditions during EMC tests

The following advice is given on the selection of operational conditions:

- operational conditions needs to be selected such that compliance criteria can be employed;
- modes of operation where all relevant units/functions are excited at short intervals are required;
- the preferred test signal is the Pseudo-Random Bit Sequence appropriate for the bit rate of the channel.

NOTE 1: Special software may be necessary in order to test appropriate system operations.

- only one mode of operation should be selected in order to limit test time;
- at least one power supply or signal port of each type found on the equipment needs to be exposed to disturbances during conducted immunity testing;
- at least one power supply or signal port of each type found on the equipment needs to be measured for conducted emission.

NOTE 2: Some tests do not apply to short cables.

C.2.3 Performance criteria during EMC tests

The following advice is given on the selection of performance criteria:

- performance criteria should be simple to verify;
- performance criteria should be specific to the main functions of the equipment (i.e. the main functions are those which determine the level). Only main functions should be monitored during the test. After the test, the auxiliary functions should be tested for loss of function (self recovery).

Performance criteria may be specified for the parameters listed below. The list suggests examples and is not exhaustive (there are no distinctions made between different equipment categories):

- acceptable bit error rate (mainly for higher bit rates; test time should not be too long);
- alarm indications;
- analogue signal/noise ratio;
- bit errors (mainly for lower bit rates);
- busy hour call attempts;
- call misrouting;
- corruption of data in process/transit;
- corruption of stored data;
- Cyclic Redundancy Check (CRC) in case of protocols with frames;
- false alarms;
- false tripping/non-tripping;
- inability to access stored data;
- incorrect allocation of charging rates;
- incorrect digits;
- jitter rate;
- loss of established calls;

- loss of frame synchronization;
- output spikes, drop-outs, ripple and noise;
- reduced input sensitivity;
- spurious responses;
- voltage/current tolerance;
- wrong allocation of frames/rates.

C.2.4 Examples of specific performance criteria

Examples of performance criteria for telecommunication equipment are given in the standard EN 300 386 [1].

C.2.5 Example of additional performance criteria (and further details of requirements) for "primary rate multiple access" equipment

For immunity testing of "primary rate multiple access" equipment, test levels of the Other than Telecommunication Centre requirements are applied. During testing, the EUT has to be operated in the same type of rack/housing used normally for installation. When carrying out immunity tests using continuous signals, testing is to additionally include an assessment of the behaviour during system start-up and synchronization onto the incoming signal. For immunity testing, the nominal line attenuation should be considered.

Annex D (informative): Bibliography

- IEC 60721 (series): "Classification of environmental conditions".
- ETSI EN 300 019: "Environmental Engineering (EE); Environmental conditions and environmental tests for telecommunications equipment".
- ETSI EN 300 127: "ElectroMagnetic Compatibility and Radio Spectrum Matters (ERM); Radiated emission testing of physically large telecommunication systems".

History

Document history		
V1.1.1	March 2000	Publication
V1.2.1	September 2002	Publication
V1.3.1	August 2005	Publication
V1.4.1	January 2014	Membership Approval Procedure MV 20140316: 2014-01-15 to 2014-03-17