

**Access and Terminals (AT);
Specification of Dual-Tone Multi-Frequency (DTMF)
Transmitters and Receivers;
Part 2: Transmitters**



Reference

RES/AT-010103

Keywords

DTMF, PSTN, signalling

ETSI

650 Route des Lucioles
F-06921 Sophia Antipolis Cedex - FRANCE

Tel.: +33 4 92 94 42 00 Fax: +33 4 93 65 47 16

Siret N° 348 623 562 00017 - NAF 742 C
Association à but non lucratif enregistrée à la
Sous-Préfecture de Grasse (06) N° 7803/88

Important notice

Individual copies of the present document can be downloaded from:

<http://www.etsi.org>

The present document may be made available in more than one electronic version or in print. In any case of existing or perceived difference in contents between such versions, the reference version is the Portable Document Format (PDF). In case of dispute, the reference shall be the printing on ETSI printers of the PDF version kept on a specific network drive within ETSI Secretariat.

Users of the present document should be aware that the document may be subject to revision or change of status. Information on the current status of this and other ETSI documents is available at

<http://portal.etsi.org/tb/status/status.asp>

If you find errors in the present document, send your comment to:

editor@etsi.fr

Copyright Notification

No part may be reproduced except as authorized by written permission.
The copyright and the foregoing restriction extend to reproduction in all media.

© European Telecommunications Standards Institute 2002.
All rights reserved.

Contents

Intellectual Property Rights	4
Foreword.....	4
1 Scope	5
2 References	5
3 Definitions, symbols and abbreviations	5
3.1 Definitions	5
3.2 Symbols.....	6
3.3 Abbreviations	6
4 DTMF Transmitter	6
4.1 Area of application	6
4.2 Signal output requirements.....	7
4.2.1 Frequency tolerances	7
4.2.2 Sending level	7
4.2.3 Unwanted frequency components when a DTMF code is being transmitted.....	8
4.2.4 Signal timing.....	8
4.2.4.1 Tone duration	8
4.2.4.2 Pause duration	8
4.2.4.3 Rise time	8
4.3 Electrical characteristics	8
4.3.1 Speech suppression	9
4.3.2 Dial tone	9
History	10

Intellectual Property Rights

IPRs essential or potentially essential to the present document may have been declared to ETSI. The information pertaining to these essential IPRs, if any, is publicly available for **ETSI members and non-members**, and can be found in ETSI SR 000 314: "*Intellectual Property Rights (IPRs); Essential, or potentially Essential, IPRs notified to ETSI in respect of ETSI standards*", which is available from the ETSI Secretariat. Latest updates are available on the ETSI Web server (<http://webapp.etsi.org/IPR/home.asp>).

Pursuant to the ETSI IPR Policy, no investigation, including IPR searches, has been carried out by ETSI. No guarantee can be given as to the existence of other IPRs not referenced in ETSI SR 000 314 (or the updates on the ETSI Web server) which are, or may be, or may become, essential to the present document.

Foreword

This ETSI Standard (ES) has been produced by ETSI Technical Committee Access and Terminals (AT), and is now submitted for the ETSI standards Membership Approval Procedure.

The present document is part 2 of a multi-part deliverable covering the Specification of Dual Tone Multi-Frequency (DTMF) Transmitters and Receivers, as identified below:

Part 1: "General";

Part 2: "Transmitters";

Part 3: "Receivers";

Part 4: " Transmitters and Receivers for use in Terminal Equipment for end-to-end signalling".

1 Scope

The present document specifies the Dual Tone Multi-Frequency (DTMF) signalling system.

The various parts of ES 201 235 [1] provide requirements for applications intending to use DTMF signalling.

The present document is intended to provide the level of detail that will enable manufacturers of telecommunications equipment incorporating DTMF signalling, to design the equipment such that it facilitates highly reliable signalling. This should not be taken to imply that any DTMF signalling system that fails to meet all the criteria described in the present document will not provide reliable signalling.

The present document is not intended to be used for the definition of regulated interfaces.

This Part 2 covers the requirements for DTMF transmitters for the case of DTMF signalling over the local loop.

2 References

The following documents contain provisions which, through reference in this text, constitute provisions of the present document.

- References are either specific (identified by date of publication and/or edition number or version number) or non-specific.
- For a specific reference, subsequent revisions do not apply.
- For a non-specific reference, the latest version applies.

- [1] ETSI ES 201 235 (all parts): "Specification of Dual Tone Multi-Frequency (DTMF) Transmitters and Receivers".
- [2] ITU-T Recommendation Q.23: "Technical features of push-button telephone sets".
- [3] ITU-T Recommendation Q.24: "Multifrequency push-button signal reception".
- [4] ETSI TR 101 182: "Analogue Terminals and Access (ATA); Definitions, abbreviations and symbols".
- [5] ITU-T Recommendation P.57: "Artificial ear".

3 Definitions, symbols and abbreviations

3.1 Definitions

For the purposes of the present document, the following terms and definitions apply:

high group: signalling frequencies, which have nominal values of 1 209 Hz, 1 336 Hz, 1 477 Hz and 1 633 Hz

low group: signalling frequencies, which have nominal values of 697 Hz, 770 Hz, 852 Hz and 941 Hz

3.2 Symbols

For the purposes of the present document, the following symbols apply:

dBm ₀	Power level expressed in decibels relative to 1 mW in a 0 dBr level reference point.
dBV	Absolute voltage level expressed in decibels relative to 1 volt.
Z _R	Reference impedance defined in TR 101 182 [4], clause 2.1.

3.3 Abbreviations

For the purposes of the present document, the following abbreviations apply:

CLI	Calling Line Identification
DTMF	Dual Tone Multi-Frequency
PBX	Private Branch Exchange
TE	Terminal Equipment

4 DTMF Transmitter

4.1 Area of application

The present part of the standard describes the properties of the DTMF transmitter function for terminal and for network equipment.

NOTE 1: DTMF Receivers designed to part 3 of the present document are compatible with DTMF Transmitters designed to this specification.

NOTE 2: The principal uses of the transmitter as dealt with in the present document are expected to be:

- a) in a TE for DTMF signalling to a local exchange (e.g. for dialling);
- b) in a TE for DTMF signalling to a PBX (e.g. for dialling);
- c) in a PBX for DTMF signalling to a LE (e.g. for dialling);
- d) in a PBX for DTMF signalling to TE (e.g. for CLI);
- e) in a local exchange for DTMF signalling to TE (e.g. for CLI);
- f) in a local exchange for DTMF signalling to a PBX (e.g. for Direct Dialling In or CLI);
- g) in a PBX for DTMF signalling to a PBX (e.g. for dialling or CLI).

A DTMF transmitter or transmitter function can be either analogue, i.e. intended for connection to an analogue point in the network, or digital, i.e. intended for connection to a digital point in the network. Figure 1 shows typical usage in a local exchange or a PBX.

Local exchange or PBX

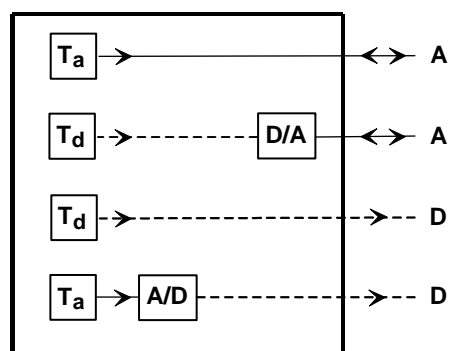

NOTE: In this figure:
 A: Analogue transmission path
 A/D: Analogue to Digital converter
 D: Digital transmission path
 D/A: Digital to Analogue converter
 Ta: Analogue DTMF transmitter
 Td: Digital DTMF transmitter

Figure 1: Reference configuration

4.2 Signal output requirements

4.2.1 Frequency tolerances

The tolerances of the output frequencies shall be within $\pm 1,5\%$ of their nominal values.

NOTE: The tolerance specified in ITU-T Recommendation Q.23 [2] is 1,8 %. However, for Europe the tolerance is considered to be 1,5 % according to the practice as presented in annex A of ITU-T Recommendation Q.24 [3].

4.2.2 Sending level

For analogue transmitters: The sending levels when the DTMF transmitter is terminated with the reference impedance Z_R , shall be:

- for the high frequency group: -9,0 dBV, +2,0 dB/-2,5 dB;
- for the low frequency group: -11,0 dBV, +2,5 dB/-2,0 dB.

The level of the higher frequency component of the signal shall be between 1 dB and 4 dB greater than the level of the lower frequency component.

For digital transmitters: The sending levels for each frequency shall be:

- for the high frequency group: -4,0 dBm0 ± 1 dB;
- for the low frequency group: -6,0 dBm0 ± 1 dB.

A digital transmitter used for sending DTMF for specific network implementations e.g. CLI, may have a sending level of up to 0 dBm0 to attain the same level on an analogue line as the analogue transmitter specified above.

NOTE: Where TE is required to produce a confidence tone in a telephone receiver, a level of about 65 dB to 85 dB relative to 20 μ Pa measured in an artificial ear complying with ITU-T Recommendation P.57 [5] may be considered acceptable.

4.2.3 Unwanted frequency components when a DTMF code is being transmitted

This requirements apply when the DTMF transmitter is terminated with the reference impedance Z_R .

a) Total power of unwanted components

The total power level of all unwanted frequency components in the frequency range of 250 Hz to 4 300 Hz shall be at least 20 dB below the level of the low group frequency component of the signal.

b) Level of individual unwanted components

In the range 4,3 kHz to 20 kHz, the individual level of any single frequency component shall not exceed -35 dBV.

In the range 20 kHz to 200 kHz, the individual level of any single frequency component shall not exceed -40 dBV.

In the range 200 kHz to 30 MHz, the individual level of any single frequency component shall not exceed -60 dBV.

NOTE 1: The purpose of this clause is to avoid interference to this and other inband signalling systems and other channels in multiplex systems.

NOTE 2: For digital transmitters, the requirements for unwanted frequency components are only applicable up to 4 000 Hz

4.2.4 Signal timing

4.2.4.1 Tone duration

Where the DTMF signalling tone duration is controlled automatically by the transmitter, the duration of any individual DTMF tone combination sent shall not be less than 65 ms. The time shall be measured from the time when the tone reaches 90 % of its steady-state value, until it has dropped to 90 % of its steady-state value.

NOTE: For correct operation of supplementary services such as CLI and Direct Dialling In, DTMF tone bursts should not be longer than 75 ms.

4.2.4.2 Pause duration

Where the DTMF signalling pause duration is controlled automatically by the transmitter the duration of the pause between any individual DTMF tone combination shall not be less than 65 ms. The time shall be measured from the time when the tone has dropped to 10 % of its steady-state value, until it has risen to 10 % of its steady-state value.

NOTE 1: In order to ensure correct reception of all the digits in a network address sequence, some networks may require a sufficient pause after the last DTMF digit signalled and before normal transmission starts.

NOTE 2: For correct operation of supplementary services such as CLI and Direct Dialling In, DTMF pause duration should not be longer than 75 ms.

4.2.4.3 Rise time

The level of each of the two frequency components of the multi-frequency signal shall be within 1dB of the final value within 7 ms from the time that a command for DTMF output signal has been send to the DTMF transmitter function.

4.3 Electrical characteristics

NOTE: The electrical characteristics of the interface will be determined by the apparatus into which the function of the DTMF transmitter has been incorporated.

4.3.1 Speech suppression

When a DTMF signal is sent to the line, the sending sensitivity of any microphone capable of sending signals to line shall be decreased by at least 50 dB.

4.3.2 Dial tone

When transmitting DTMF tone combinations in the presence of dial tone, the spectral output shall comply with the requirements of clause 4.2.3.

For the purpose of this requirement, the dial tone is defined as a single tone signal, delivered from a generator with a source impedance equal to Z_R , with a frequency of 425 Hz, at the level of -10 dBV when measured across the reference impedance Z_R .

History

Document history		
V1.1.1	September 2000	Publication
V1.2.1	March 2002	Membership Approval Procedure MV 20020503: 2002-03-05 to 2002-05-03