

**Digital Video Broadcasting (DVB);  
DVB interaction channel for Cable TV  
distribution systems (CATV)**

---

European Broadcasting Union



Union Européenne de Radio-Télévision



---

**Reference**

RES/JTC-DVB-116

---

**Keywords**broadcasting, cable, digital, DVB, interaction, TV,  
video**ETSI**

---

650 Route des Lucioles  
F-06921 Sophia Antipolis Cedex - FRANCE

Tel.: +33 4 92 94 42 00 Fax: +33 4 93 65 47 16

Siret N° 348 623 562 00017 - NAF 742 C  
Association à but non lucratif enregistrée à la  
Sous-Préfecture de Grasse (06) N° 7803/88

---

**Important notice**

Individual copies of the present document can be downloaded from:

<http://www.etsi.org>

The present document may be made available in more than one electronic version or in print. In any case of existing or perceived difference in contents between such versions, the reference version is the Portable Document Format (PDF). In case of dispute, the reference shall be the printing on ETSI printers of the PDF version kept on a specific network drive within ETSI Secretariat.

Users of the present document should be aware that the document may be subject to revision or change of status. Information on the current status of this and other ETSI documents is available at <http://www.etsi.org/tb/status/>

If you find errors in the present document, send your comment to:  
[editor@etsi.fr](mailto:editor@etsi.fr)

---

**Copyright Notification**

No part may be reproduced except as authorized by written permission.  
The copyright and the foregoing restriction extend to reproduction in all media.

© European Telecommunications Standards Institute 2001.  
© European Broadcasting Union 2001.  
All rights reserved.

# Contents

Intellectual Property Rights .....	7
Foreword .....	7
1 Scope.....	8
2 References .....	8
3 Abbreviations .....	9
4 Reference Model for System Architecture of Narrowband Interaction Channels in a Broadcasting Scenario (Asymmetric Interactive Services) .....	10
4.1 Protocol Stack Model .....	10
4.2 System Model .....	11
5 DVB Interaction Channel Specification for CATV Networks .....	13
5.1 System Concept.....	13
5.1.1 Out-Of-Band/In-Band Principle.....	13
5.1.2 Spectrum Allocation .....	13
5.1.3 FDM/TDMA Multiple Access.....	14
5.1.4 Bit Rates and Framing.....	15
5.2 Lower Physical Layer Specification .....	16
5.2.1 Forward Interaction Path (Downstream OOB) .....	17
5.2.1.1 Frequency Range (Downstream OOB) .....	17
5.2.1.2 Modulation and Mapping (Downstream OOB) .....	18
5.2.1.3 Shaping Filter (Downstream OOB) .....	18
5.2.1.4 Randomizer (Downstream OOB) .....	20
5.2.1.5 Bit Rate (Downstream OOB) .....	20
5.2.1.6 Receiver power level (Downstream OOB).....	20
5.2.1.7 Summary (Downstream OOB) .....	21
5.2.1.8 Bit Error Rate Downstream OOB (Informative).....	21
5.2.2 Forward Interaction Path (Downstream IB) .....	21
5.2.3 Return Interaction Path (Upstream) .....	22
5.2.3.1 Frequency Range (Upstream).....	22
5.2.3.2 Modulation and Mapping (Upstream).....	22
5.2.3.3 Shaping Filter (Upstream).....	23
5.2.3.4 Randomizer (Upstream).....	24
5.2.3.5 Pre Equalizer .....	25
5.2.3.6 Bit Rate (Upstream).....	25
5.2.3.7 Transmit Power Level (Upstream) .....	26
5.2.3.8 Upstream Burst Power and Timing Profiles.....	26
5.2.3.9 Interference (Spurious) Suppression.....	27
5.2.3.10 Summary (Upstream).....	28
5.2.3.11 Packet loss Upstream (Informative).....	29
5.2.3.12 Maximum Cable Delay .....	29
5.3 Framing .....	29
5.3.1 Forward Interaction Path (Downstream OOB) .....	29
5.3.1.1 Signalling Link Extended Superframe Framing Format .....	29
5.3.1.2 Frame overhead.....	30
5.3.1.3 Payload Structure.....	31
5.3.2 Forward Interaction Path (Downstream IB) .....	38
5.3.2.1 IB Signalling MPEG2-TS Format (MAC Control Message) .....	38
5.3.2.2 Frequency of IB Signalling Information .....	41
5.3.3 Return Interaction Path (Upstream) .....	41
5.3.3.1 Slot Format.....	41
5.3.4 Minimum Processing Time .....	43
5.4 Slot Timing Assignment.....	44
5.4.1 Downstream Slot Position Reference (Downstream OOB) .....	44
5.4.2 Downstream Slot Position Reference (Downstream IB) .....	44

5.4.3	Upstream Slot Positions .....	46
5.4.3.1	Rate 256 kbit/s QPSK, 512 kbit/s 16QAM .....	47
5.4.3.2	Rate 1,544 Mbit/s QPSK, 3,088 Mbit/s 16QAM.....	47
5.4.3.3	Rate 3,088 Mbit/s QPSK, 6,176 Mbit/s 16QAM.....	48
5.4.3.4	Rate 6,176 Mbit/s QPSK, 12,352 Mbit/s 16QAM.....	49
5.4.4	Slot Position Counter .....	50
5.5	MAC Functionality .....	52
5.5.1	MAC Reference Model .....	52
5.5.2	MAC Concept.....	53
5.5.2.1	Relationship Between Higher Layers and MAC Protocol.....	53
5.5.2.2	Relationship Between Physical Layer and MAC Protocol.....	53
5.5.2.3	Relationship Between Physical Layer Slot Position Counter and MAC Slot Assignment.....	55
5.5.2.4	Access Modes (Contention/Ranging/Fixed rate/Reservation).....	56
5.5.2.5	MAC Error Handling Procedures .....	57
5.5.2.6	MAC Messages in the Mini Slots.....	57
5.5.2.7	MAC Message Format.....	60
5.5.3	MAC Initialization and Provisioning .....	63
5.5.3.1	<MAC> Provisioning Channel Message (Broadcast Downstream).....	64
5.5.3.2	<MAC> Default Configuration Message (Broadcast Downstream) .....	64
5.5.4	Sign On and Calibration.....	70
5.5.4.1	<MAC> Sign-On Request Message (Broadcast Downstream).....	70
5.5.4.2	<MAC> Sign-On Response Message (Upstream Ranging) .....	72
5.5.4.3	<MAC> Ranging and Power Calibration Message (Singlecast Downstream) .....	74
5.5.4.4	<MAC> Ranging and Power Calibration Response Message (Upstream Ranging or reserved) .....	75
5.5.4.5	<MAC> Initialization Complete Message (Singlecast Downstream) .....	76
5.5.5	Connection Establishment.....	76
5.5.5.1	Establishment of the First (Initial) Connection.....	76
5.5.5.2	Establishment of Additional Connections.....	86
5.5.6	Connection Release.....	91
5.5.7	Fixed Rate Access.....	92
5.5.8	Contention Based Access .....	92
5.5.9	Reservation Access .....	92
5.5.10	MAC Link Management .....	100
5.5.10.1	Power, Timing and Equalizer Management .....	100
5.5.10.2	TDMA Allocation Management.....	100
5.5.10.3	Channel Error Management .....	109
5.5.10.4	Link Management Messages .....	110
5.6	Minislots.....	118
5.6.1	Carrying Minislots .....	118
5.6.2	Minislot framing structure.....	118
5.6.3	Contention resolution for minislots.....	119
5.7	Header Suppression .....	121
5.7.1	The Suppression Scheme.....	121
5.7.2	Suppression Algorithm.....	121
5.7.3	Negotiation of the Suppression Scheme.....	122
5.7.4	Suppression Header.....	123
5.7.5	Header Suppression <MAC> Messages .....	124
5.7.5.1	<MAC> Suppression Data Message.....	124
5.7.5.2	<MAC> Suppression Acknowledgment Message .....	125
5.7.6	Suppression of RTP sessions .....	125
5.8	Security (optional).....	127
5.8.1	Cryptographic primitives.....	127
5.8.1.1	Public key exchange .....	128
5.8.1.2	Hashing.....	128
5.8.1.3	Encryption.....	128
5.8.1.4	Pseudo-random numbers.....	129
5.8.2	Main Key Exchange, MKE .....	129
5.8.3	Quick Key Exchange, QKE.....	130
5.8.4	Explicit Key Exchange, EKE.....	130
5.8.5	Key derivation .....	130
5.8.6	Data stream processing.....	130
5.8.6.1	Payload streams.....	131

5.8.6.2	Data encryption .....	131
5.8.6.3	Encryption flags .....	131
5.8.6.4	Chaining and initialization vector .....	132
5.8.7	Security Establishment .....	132
5.8.8	Persistent state variables .....	133
5.8.8.1	Guaranteed delivery .....	133
5.8.9	Security MAC Messages .....	133
5.8.9.1	<MAC>Security Sign-On (Single-cast Downstream) .....	133
5.8.9.2	<MAC>Security Sign-On Response (Upstream) .....	134
5.8.9.3	<MAC>Main Key Exchange (Single-cast Downstream) .....	135
5.8.9.4	<MAC>Main Key Exchange Response (Upstream) .....	136
5.8.9.5	<MAC>Quick Key Exchange (Single-cast Downstream) .....	136
5.8.9.6	<MAC>Quick Key Exchange Response (Upstream) .....	137
5.8.9.7	<MAC>Explicit Key Exchange (Single-cast Downstream) .....	137
5.8.9.8	<MAC>Explicit Key Exchange Response (Upstream) .....	138
5.8.9.9	<MAC>Wait (Upstream) .....	138
6	Interactive Cable STB/Cable Data Modem Mid Layer Protocol .....	139
6.1	Direct IP .....	139
6.1.1	Framing .....	139
6.1.1.1	Upstream and OOB Downstream .....	139
6.1.1.2	IB Downstream .....	139
6.1.2	Addressing .....	139
6.1.2.1	IP Broadcast and Multicast from STB/NIU to INA .....	140
6.1.2.2	IP Broadcast and Multicast from INA to STB/NIU .....	140
6.1.3	IP Address Assignment .....	140
6.1.4	INA Interfaces (Informative) .....	140
6.1.5	NIU/STB Interfaces (Informative) .....	140
6.2	Ethernet MAC Bridging .....	140
6.2.1	Framing .....	140
6.2.1.1	Upstream and OOB Downstream .....	140
6.2.1.2	IB Downstream .....	141
6.2.2	Addressing .....	141
6.3	PPP .....	141
6.3.1	Framing .....	141
6.3.1.1	Upstream and OOB Downstream .....	141
6.3.1.2	IB Downstream .....	141
6.3.2	Addressing .....	141
6.3.3	IP Address Assignment .....	141
6.3.4	Additional IP addresses .....	142
6.3.5	Security .....	142
6.3.6	INA Interfaces (informative) .....	142
6.3.7	NIU/STB Interfaces (informative) .....	142
<b>Annex A (informative): MAC State Transitions and Time Outs .....</b>		<b>143</b>
A.1	Initialization, Provisioning, Sign-On and Calibration .....	144
A.2	Connection Establishment .....	147
A.3	Connection Release .....	148
A.4	Reservation Process .....	148
A.5	Resource Request .....	151
A.6	Recalibration .....	153
A.7	Reprovision Message .....	153
A.8	Transmission Control Message .....	153
A.9	Status Request Message .....	154
A.10	Idle Message .....	155

<b>Annex B (informative):</b>	<b>MAC Primitives .....</b>	<b>156</b>
B.1	Control and Resource Primitives .....	157
B.1.1	On STB/CM side.....	157
B.1.1.1	<Prim> MAC_ACTIVATION_REQ.....	157
B.1.1.2	<Prim> MAC_ACTIVATION_CNF.....	157
B.1.1.3	<Prim> MAC_CONNECT_IND .....	159
B.1.1.4	<Prim>MAC_RSV_ID_IND.....	160
B.1.1.5	<Prim> MAC_RELEASE_IND.....	160
B.1.1.6	<Prim> MAC_RESOURCE_REQ.....	161
B.1.1.7	<Prim>MAC_RESOURCE_CNF.....	162
B.1.1.8	<Prim>MAC_RESOURCE_DENIED_IND .....	162
B.1.2	On INA side.....	163
B.1.2.1	<Prim> MAC_INA_RESOURCE_REQ.....	163
B.1.2.2	<Prim> MAC_INA_RESOURCE_IND.....	164
B.2	Data Primitives .....	166
B.2.1	<Prim> DL_DATA_IND.....	166
B.2.2	<Prim> DL_DATA_REQ.....	166
B.2.3	<Prim> MAC_DATA_IND.....	166
B.2.4	<Prim> MAC_DATA_REQ.....	167
B.2.5	<Prim> MAC_DATA_CONF.....	167
B.3	Example MAC Control Scenarios .....	168
B.3.1	Example MAC Control Scenario on STB/CM Side .....	168
B.3.2	Example Resource Management Scenario on STB/CM Side.....	169
B.3.3	Example Resource Management Scenario on INA Side.....	170
B.3.4	Example Upstream Data Transfer Scenarios.....	171
<b>Annex C (informative):</b>	<b>Bibliography.....</b>	<b>172</b>
History .....		173

---

## Intellectual Property Rights

IPRs essential or potentially essential to the present document may have been declared to ETSI. The information pertaining to these essential IPRs, if any, is publicly available for **ETSI members and non-members**, and can be found in ETSI SR 000 314: "*Intellectual Property Rights (IPRs); Essential, or potentially Essential, IPRs notified to ETSI in respect of ETSI standards*", which is available from the ETSI Secretariat. Latest updates are available on the ETSI Web server (<http://www.etsi.org/ipr>).

Pursuant to the ETSI IPR Policy, no investigation, including IPR searches, has been carried out by ETSI. No guarantee can be given as to the existence of other IPRs not referenced in ETSI SR 000 314 (or the updates on the ETSI Web server) which are, or may be, or may become, essential to the present document.

---

## Foreword

This ETSI Standard (ES) has been produced by the Joint Technical Committee (JTC) Broadcast of the European Broadcasting Union (EBU), Comité Européen de Normalisation ELECTrotechnique (CENELEC) and the European Telecommunications Standards Institute (ETSI), and is now submitted for the ETSI standards Membership Approval Procedure.

NOTE: The EBU/ETSI JTC Broadcast was established in 1990 to co-ordinate the drafting of standards in the specific field of broadcasting and related fields. Since 1995 the JTC Broadcast became a tripartite body by including in the Memorandum of Understanding also CENELEC, which is responsible for the standardization of radio and television receivers. The EBU is a professional association of broadcasting organizations whose work includes the co-ordination of its members' activities in the technical, legal, programme-making and programme-exchange domains. The EBU has active members in about 60 countries in the European broadcasting area; its headquarters is in Geneva.

European Broadcasting Union  
CH-1218 GRAND SACONNEX (Geneva)  
Switzerland  
Tel: +41 22 717 21 11  
Fax: +41 22 717 24 81

Founded in September 1993, the DVB Project is a market-led consortium of public and private sector organizations in the television industry. Its aim is to establish the framework for the introduction of MPEG-2 based digital television services. Now comprising over 200 organizations from more than 25 countries around the world, DVB fosters market-led systems, which meet the real needs, and economic circumstances, of the consumer electronics and the broadcast industry.

---

# 1 Scope

The present document is the baseline specification for the provision of the interaction channel for CATV networks.

It is not intended to specify a return channel solution associated to each broadcast system because the inter-operability of different delivery media to transport the return channel is desirable.

The solutions provided in the present document for interaction channel for CATV networks are a part of a wider set of alternatives to implement interactive services for Digital Video Broadcasting (DVB) systems.

---

# 2 References

The following documents contain provisions which, through reference in this text, constitute provisions of the present document.

- References are either specific (identified by date of publication and/or edition number or version number) or non-specific.
- For a specific reference, subsequent revisions do not apply.
- For a non-specific reference, the latest version applies.

- [1] ITU-T Recommendation I.361 (1999): "B-ISDN ATM layer specification".
- [2] ITU-T Recommendation I.363: "B-ISDN ATM Adaptation Layer (AAL) specification".
- [3] ANSI X3.92 (1981): "Data Encryption Algorithm".
- [4] ANSI X3.106 (1983): "Data Encryption Algorithm, Modes of Operation for the".
- [5] IETF RFC 2104: "HMAC: Keyed-Hashing for Message Authentication".
- [6] ETSI EN 301 192: "Digital Video Broadcasting (DVB); DVB specification for data broadcasting".
- [7] ETSI EN 300 429: "Digital Video Broadcasting (DVB); Framing structure, channel coding and modulation for cable systems".
- [8] IETF RFC 1483: "Multiprotocol Encapsulation over ATM Adaptation Layer 5".
- [9] IETF RFC 2131: "Dynamic Host Configuration Protocol".
- [10] IETF RFC 951: "Bootstrap Protocol (BOOTP)".
- [11] IETF RFC 791: "Internet Protocol".
- [12] ATM Forum (af-uni-0010.002): "ATM User-Network Interface Specification V3.1".
- [13] IETF RFC 2236: "Internet Group Management Protocol, Version 2".
- [14] ETSI TR 100 815: "Digital Video Broadcasting (DVB); Guidelines for the handling of Asynchronous Transfer Mode (ATM) signals in DVB systems".
- [15] ISO/IEC 8802-3 (1996): "Information technology - Telecommunications and information exchange between systems - Local and metropolitan area networks - Specific requirements - Part 3: Carrier sense multiple access with collision detection (CSMA/CD) access method and physical layer specifications".
- [16] ITU-T Recommendation I.432: "B-ISDN User-Network Interface - Physical layer specification".
- [17] ETSI TR 101 196: "Digital Video Broadcasting (DVB); Interaction channel for Cable TV distribution systems (CATV); Guidelines for the use of ETS 300 800".



- [18] ETSI EN 301 199: "Digital Video Broadcasting (DVB); Interaction channel for Local Multi-point Distribution Systems (LMDS)".
- [19] EN 50083-2: "Cabled distribution systems for television, sound and interactive multimedia signals - Part 2: Electromagnetic compatibility for equipment".
- [20] ISO/IEC 13818-1: "Information technology - Generic coding of moving pictures and associated audio information: Systems".
- [21] ETSI EN 300 468: "Digital Video Broadcasting (DVB); Specification for Service Information (SI) in DVB systems".
- [22] IETF RFC 2364: "PPP Over AAL5".
- [23] IETF RFC 1332: "The PPP Internet Protocol Control Protocol (IPCP)".
- [24] ETSI ETS 300 800: "Digital Video Broadcasting (DVB); Interaction channel for Cable TV distribution systems (CATV)".

---

### 3 Abbreviations

For the purposes of the present document, the following abbreviations apply:

ATM	Asynchronous Transfer Mode
BC	Broadcast Channel
BIM	Broadcast Interface Module
BRA	Basic Rate Access
CATV	Community Antenna TeleVision (System)
CBC	Cipher Block Chaining
CM	Cable Modem
Connection ID	Connection Identifier
CRC	Cyclic Redundancy Check
DAVIC	Digital Audiovisual Council
DCE	Data Communication Equipment
DES	Data Encryption Standard
D-H	Diffie-Hellman
DL	Data Link
DTE	Data Termination Equipment
DTMF	Dual Tone Multifrequency (dialling mode)
DVB	Digital Video Broadcasting
EKE	Explicit Key Exchange
FAS	Frame Alignment Signal
FIFO	First In First Out
GSTN	General Switched Telephone Network
HEC	Header Error Control
HMAC	Hash-based Message Authentication Code
IB	In-Band
IC	Interaction Channel
IIM	Interactive Interface Module
INA	Interactive Network Adapter
IQ	In-phase and Quadrature components
IRD	Integrated Receiver Decoder
ISDN	Integrated Services Digital Network
IV	Initialization Vector
LFSR	Linear Feedback Shift Register
LSB	Least Significant Bit
MAC	Media Access Control
MKE	Main Key Exchange
MMDS	Multi-channel Multi-point Distribution Systems
MPEG	Moving Pictures Experts Group
MSB	Most Significant Bit

MTU	Maximum Transmission Unit
NIU	Network Interface Unit
NSAP	Network Service Access Point
OH	OverHead
OOB	Out of Band
OSI	Open Systems Interconnection
PID	Packet Identifier, defined by ISO/IEC 13818-1 (MPEG-2) [20]
PM	Pulse Modulation
PRNG	Pseudo-Random Number Generator
PSTN	Public Switched Telephone Network
QAM	Quadrature Amplitude Modulation
QKE	Quick Key Exchange
QoS	Quality of Service
QPSK	Quaternary Phase Shift Keying
Reservation ID	Reservation Identifier
SHA-1	Secure Hash Algorithm 1
SL-ESF	Signalling Link Extended SuperFrame
SMATV	Satellite Master Antenna Television
STB	Set Top Box
STU	Set Top Unit
TDMA	Time Division Multiplex Access
TS	Transport Stream
VCI	ATM Virtual Channel Identification, defined by ITU-T Recommendation I.363 [2]
VPI	ATM Virtual Path Identification, defined by ITU-T Recommendation I.363 [2]

---

## 4 Reference Model for System Architecture of Narrowband Interaction Channels in a Broadcasting Scenario (Asymmetric Interactive Services)

### 4.1 Protocol Stack Model

For asymmetric interactive services supporting broadcast to the home with narrowband return channel, a simple communications model consists of the following layers:

- **physical layer:** where all the physical (electrical) transmission parameters are defined;
- **transport layer:** defines all the relevant data structures and communication protocols like data containers, etc.;
- **application layer:** interactive application software and runtime environments (e.g. home shopping application, script interpreter, etc.).

A simplified model of the OSI layers was adopted to facilitate the production of specifications for these nodes. Figure 1 points out the lower layers of the simplified model and identifies some of the key parameters for the lower two layers. Following the user requirements for interactive services, no attempt will be made to consider higher layers in the present document.

Layer structure for generic system reference model

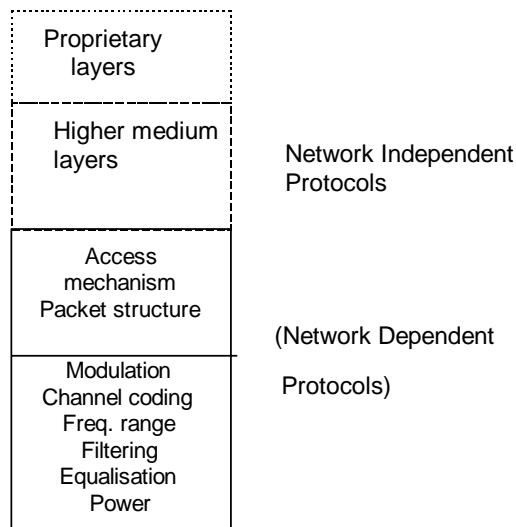

Figure 1: Layer structure for generic system reference model

This specification addresses the CATV network specific aspects only.

## 4.2 System Model

Figure 2 shows the system model which is to be used within DVB for interactive services.

In the system model, two channels are established between the Service provider and the User:

- **Broadcast Channel (BC):** a unidirectional broadband Broadcast Channel including video, audio and data. BC is established from the service provider to the users. It may include the Forward Interaction path.
- **Interaction Channel (IC):** a Bi-directional Interaction Channel is established between the service provider and the user for interaction purposes. It is formed by:
  - **Return Interaction path (Return Channel):** from the User to the Service Provider. It is used to make requests to the service provider or to answer questions. It is a narrowband channel. Also commonly known as return channel.
  - **Forward Interaction path:** from the service provider to the user. It is used to provide some sort of information by the service provider to the user and any other required communication for the interactive service provision. It may be embedded into the broadcast channel. It is possible that this channel is not required in some simple implementations which make use of the Broadcast Channel for the carriage of data to the user.

The user terminal is formed by the Network Interface Unit (NIU) (consisting of the Broadcast Interface Module (BIM) and the Interactive Interface Module (IIM)) and the Set Top Unit (STU). The user terminal provides interface for both broadcast and interaction channels. The interface between the user terminal and the interaction network is via the Interactive Interface Module.

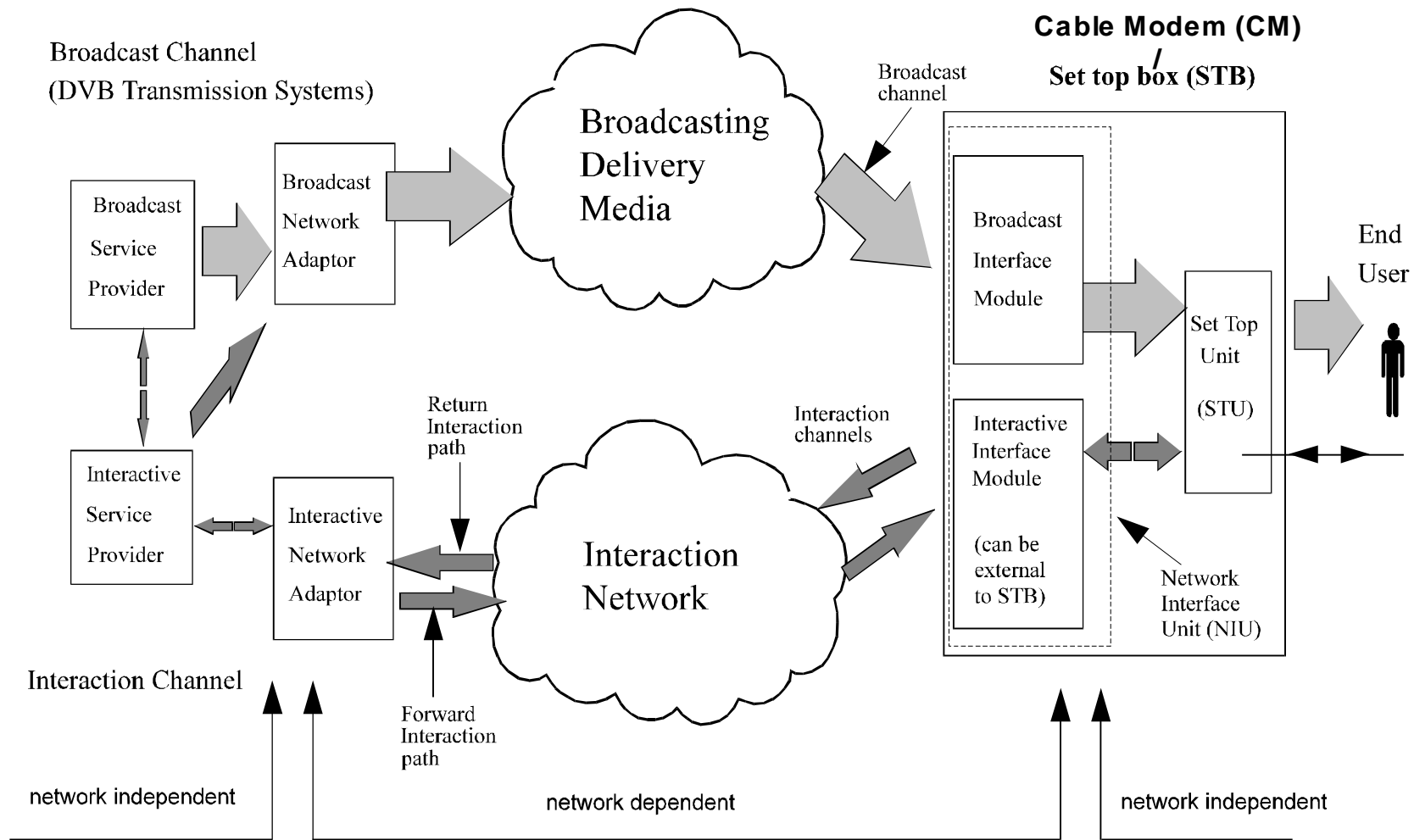

Figure 2: A generic system Reference Model for Interactive Systems

---

## 5 DVB Interaction Channel Specification for CATV Networks

The CATV infrastructures can support the implementation of the Return Channel for interactive services suitable for DVB broadcasting systems.

CATV can be used to implement interactive services in the DVB environment, providing a bi-directional communication path between the user terminal and the service provider.

### 5.1 System Concept

The interactive system is composed of Forward Interaction path (downstream) and Return Interaction path (upstream). The general concept is to use downstream transmission from the INA to the NIUs to provide synchronization and information to all NIUs. This allows the NIUs to adapt to the network and send synchronized information upstream.

Upstream transmission is divided into time slots which can be used by different users, using the technique of Time Division Multiple Access (TDMA). One downstream channel is used to synchronize up to 8 upstream channels, which are all divided into time slots. A counter at the INA is sent periodically to the NIUs, so that all NIUs work with the same clock. This gives the opportunity to the INA to assign time slots to different users.

Three major access modes are provided with this system. The first one is based on contention access, which lets users send information at any time with the risk to have a collision with other user's transmissions. The second and third modes are contention-less based, where the INA either provides a finite amount of slots to a specific NIU, or a given bit rate requested by a NIU until the INA stops the connection. These access modes are dynamically shared among time slots, which allows NIUs to know when contention based transmission is or is not allowed. This is to avoid a collision for the two contention-less based access modes.

Periodically, the INA will indicate to new users that they have the possibility to go through sign-on procedure, in order to give them the opportunity to synchronize their clock to the network clock, without risking collisions with already active users. This is done by leaving a larger time interval for new users to send their information, taking into account the propagation time required from the INA to the NIUs and back.

#### 5.1.1 Out-Of-Band/In-Band Principle

This interactive system is based either on out of band (OOB) or in-band (IB) downstream signalling. However, Set Top Boxes/Cable Modems do not need to support both systems.

In the case of OOB signalling, a Forward Interaction path is mandatory. This path is reserved for interactivity data and control information only. However, it is also possible to send higher bit rate downstream information through a DVB-C channel whose frequency is indicated in the forward information path.

In the case of IB signalling, the Forward Information path is embedded into the MPEG-2 TS of a DVB-C channel. Note that it is not mandatory to include the Forward Information path in all DVB-C channels.

Both systems can provide the same quality of service. However, the overall system architecture will differ between networks using IB Set Top Boxes/Cable Modems and OOB Set Top Boxes/Cable Modems. Note also that both types of systems may exist on the same networks under the condition that different frequencies are used for each system.

#### 5.1.2 Spectrum Allocation

Figure 3 indicates a possible spectrum allocation. Although not mandatory, a guideline is provided to use the following preferred frequency ranges, 70 MHz to 130 MHz and/or 300 MHz to 862 MHz for the Forward Interaction path (downstream OOB) and 5 MHz to 65 MHz for the Return Interaction path (upstream), or parts thereof. To avoid filtering problems in the bi-directional RF amplifiers and in the Set Top Boxes/Cable Modems, the upper limit 65 MHz for the upstream flow shall not be used together with the lower limit 70 MHz for the downstream flow in the same system. Furthermore, to avoid intermediate frequency impairments of Set Top Boxes/Cable Modems as well as analogue receivers in the same network, it could be necessary to leave out some parts of the range 5 MHz to 65 MHz which includes the intermediate frequency ranges of these appliances.

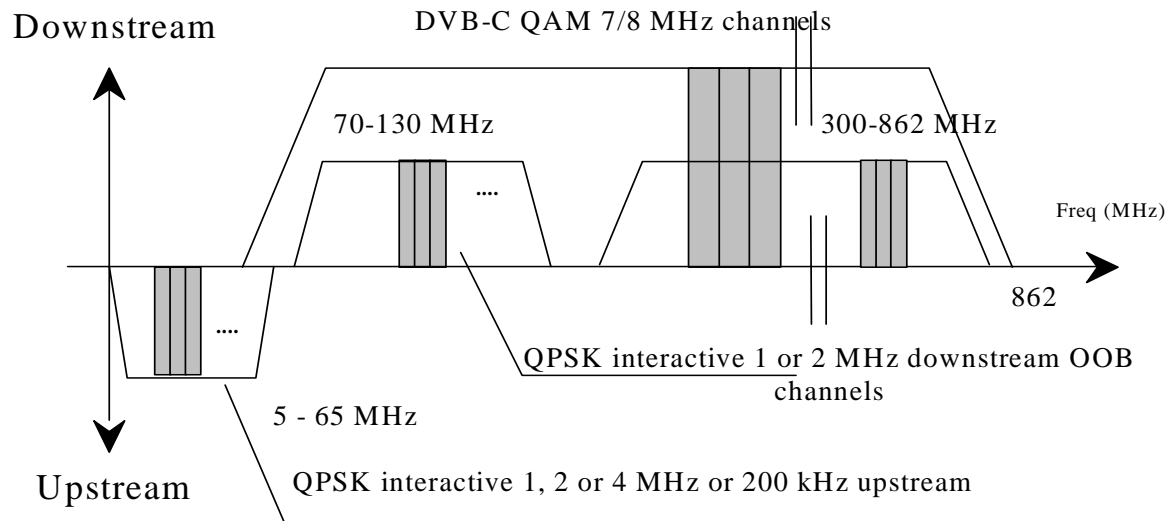

**Figure 3: DVB preferred frequency ranges for CATV interactive systems**

### 5.1.3 FDM/TDMA Multiple Access

A multiple access scheme is defined in order to have different users share the same transmission media. Downstream information is sent broadcast to all users of the networks. Thus, an address assignment exists for each user which allows the INA to send information single cast to one particular user. Two addresses are stored in the Set Top Boxes/Cable Modems in order to identify users on the network:

**MAC address:** It is a 48-bit value representing the unique MAC address of the NIU. This MAC address may be hard coded in the NIU or be provided by external source.

**NSAP address:** It is a 160-bit value representing a network address. This address is provided by higher layers during communication.

Upstream information may come from any user in the network and shall therefore also be differentiated at the INA using the set of addresses defined above.

Upstream and OOB downstream channels are divided into separate channels of 1 or 2 MHz bandwidth for downstream and 1, 2 or 4 MHz or 200 kHz for upstream. Each downstream channel contains a synchronization frame used by up to 8 different upstream channels, whose frequencies are indicated by the Media Access Control (MAC) protocol.

Within upstream channels, users send upstream packets with TDMA type access. This means that each channel is shared by many different users, who can either send upstream packets with a possibility of collisions when this is allowed by the INA, or request transmission and use the slots assigned by the INA to each user specifically. Assuming each channel can therefore accommodate thousands of users at the same time, the upstream bandwidth can easily be used by all users present on the network at the same time.

The TDMA technique utilizes a slotting methodology which allows the transmit start times to be synchronized to a common clock source. Synchronizing the start times increases message throughput of this signalling channel since the upstream packets do not overlap during transmission. The period between sequential start times are identified as slots. Each slot is a point in time when an upstream packet can be transmitted over the signalling link.

The time reference for slot location is received via the downstream channels generated at the Delivery System and received simultaneously by all set-top units. Note that this time reference is not sent in the same way for OOB and IB signalling. Since all NIUs' reference the same time base, the slot times are aligned for all NIUs'. However, since there is propagation delay in any transmission network, a time base ranging method accommodates deviation of transmission due to propagation delay.

Since the TDMA signalling link is used by NIUs that are engaged in interactive sessions, the number of available message slots on this channel is dependent on the number of simultaneous users. When messaging slots are not in use, an NIU may be assigned multiple message slots for increased messaging throughput. Additional slot assignments are provided to the NIU from the downstream signalling information flow.

There are different access modes for the upstream slots:

- reserved slots with fixed rate reservation (Fixed rate Access: the user has a reservation of one or several timeslots in each frame enabling, e.g. for voice, audio);
- reserved slots with dynamic reservation (Reservation Access: the user sends control information announcing his demand for transmission capacity. He gets grants for the use of slots);
- contention based slots (these slots are accessible for every user. Collision is possible and solved by a contention resolution protocol);
- ranging slots (these slots are used upstream to measure and adjust the time delay and the power).

These slots may be mixed on a single carrier to enable different services on one carrier only. If one carrier is assigned to one specific service, only those slot types will be used which are needed for this service.

### 5.1.4 Bit Rates and Framing

For the interactive downstream OOB channel, a transmission bit rate of 1,544 Mbit/s or 3,088 Mbit/s may be used. The support of 3,088 Mbit/s is mandatory, of 1,544 Mbit/s is optional for both INA and NIU. For downstream IB channels, no other constraints than those specified in the DVB-C specifications exist, but a guideline is to use rates multiples of 8 kbit/s.

Downstream OOB channels continuously transmit a frame based on T1 type framing, in which some information is provided for synchronization of upstream slots. Downstream IB channels transmit some MPEG-2 TS packets with a specific PID for synchronization of upstream slots (at least one MPEG-2 TS packet containing synchronization information shall be sent in every period of 3 ms).

For upstream transmission, the INA can indicate 8 types of transmission channels to the users: 6,176 Mbit/s with QPSK modulation, 12,352 Mbit/s with 16QAM modulation, 3,088 Mbit/s with QPSK modulation, 6,176 Mbit/s with 16QAM modulation, 1,544 Mbit/s with QPSK modulation, 3,088 Mbit/s with 16QAM modulation, 256 kbit/s with QPSK modulation and 512 kbit/s with 16QAM modulation. The support of 3,088 Mbit/s with QPSK modulation is mandatory, of other combinations of rates and modulations is optional for both INA and NIU. The INA is responsible of indicating which rate and modulation may be used by NIUs. All NIUs and INAs shall support QPSK modulation.

There are two options for the upstream framing, depending on the modulation type. QPSK slot framing consists of upstream packets of 512 bits (256 symbols). 16QAM slot framing consists of upstream packets of 1024 bits (256 symbols). The bits are sent in a bursty mode from the different users present on the network. The upstream slot rates are 12 000 upstream slots/s when the upstream transmission bit rate is 6,176 Mbit/s (QPSK)/12,352 Mbit/s (16QAM), 6 000 upstream slots/s when the upstream transmission bit rate is 3,088 Mbit/s (QPSK)/12,176 Mbit/s (16QAM), 3 000 upstream slots/s when the upstream transmission bit rate is 1,544 Mbit/s (QPSK)/3,088 Mbit/s (16QAM) and 500 upstream slots/s when the upstream transmission bit rate is 256 kbit/s (QPSK)/512 kbit/s (16QAM).

Through the present document, the term **upstream packet** refers to the overall data that is transmitted in a single burst. One upstream packet may contain 1 or 2 ATM cells, depending on the modulation type.

## 5.2 Lower Physical Layer Specification

In this clause, detailed information is given on the lower physical layer specification.

Figures 4 and 5 show the conceptual block diagrams for implementation of the present specification.

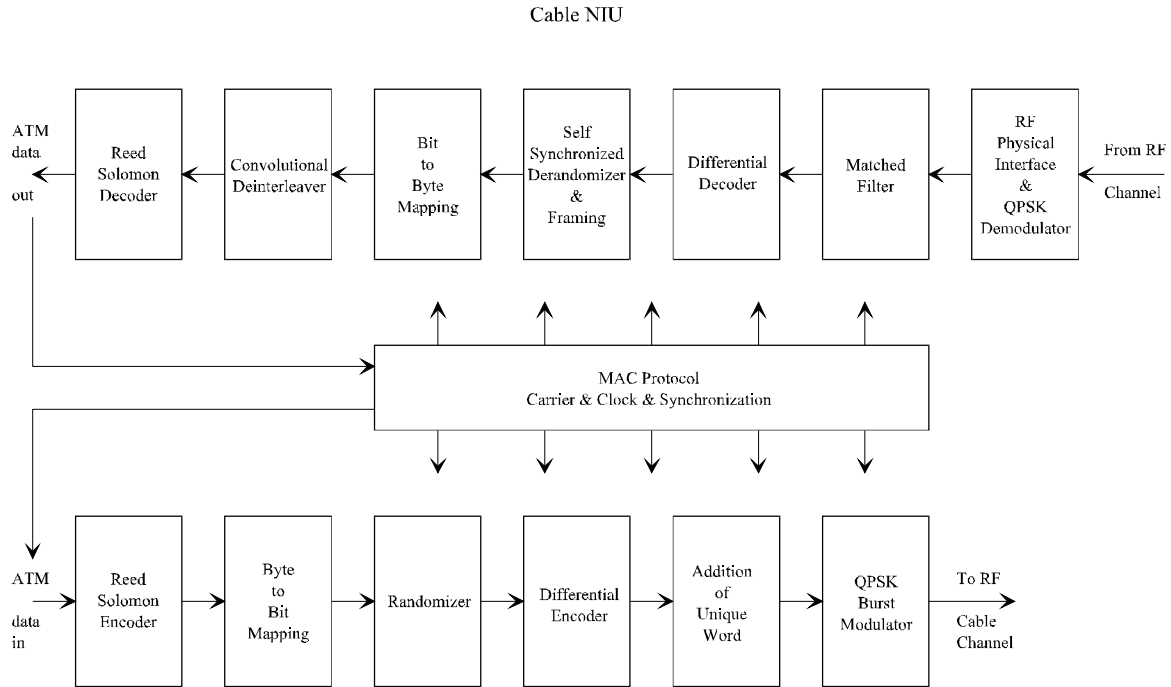

**Figure 4: Conceptual Block Diagram for the NIU OOB Transceiver**

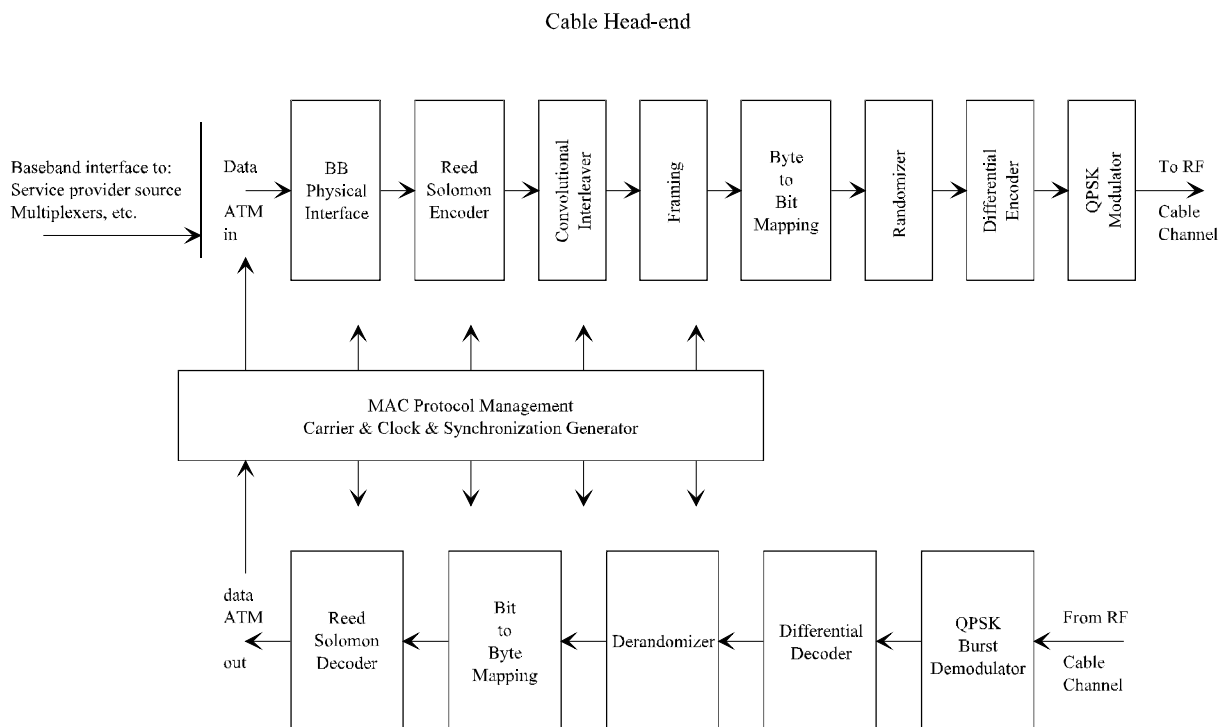

**Figure 5: Conceptual Block Diagram for the OOB Head-End Transceiver**



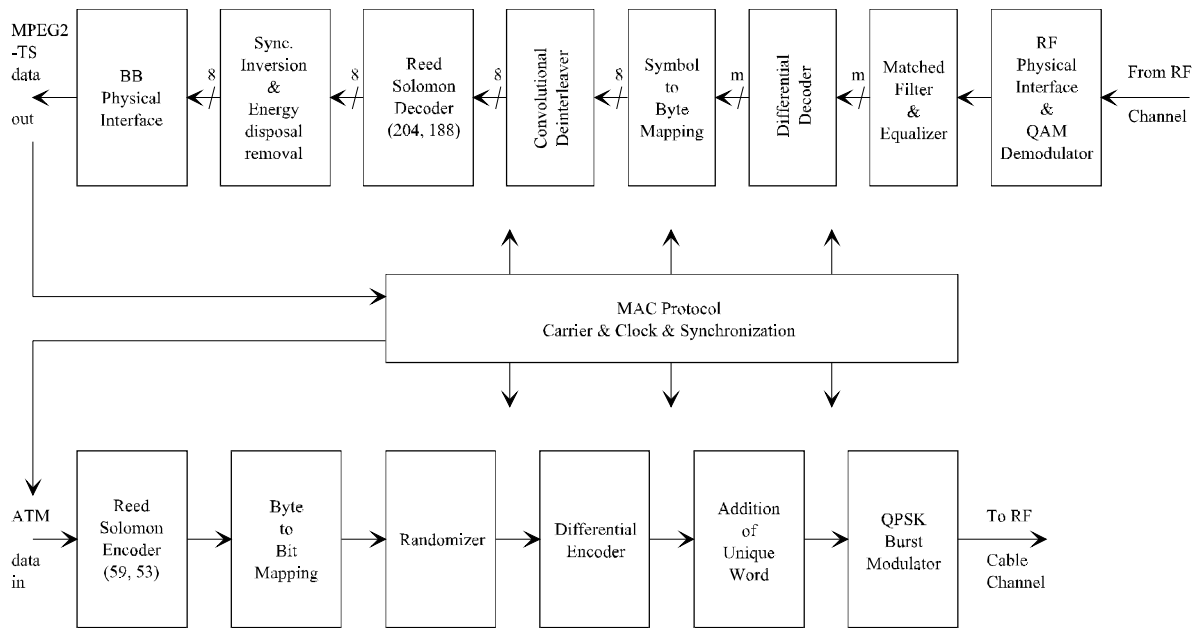

Figure 6: Conceptual Block Diagram for the IB NIU Transceiver

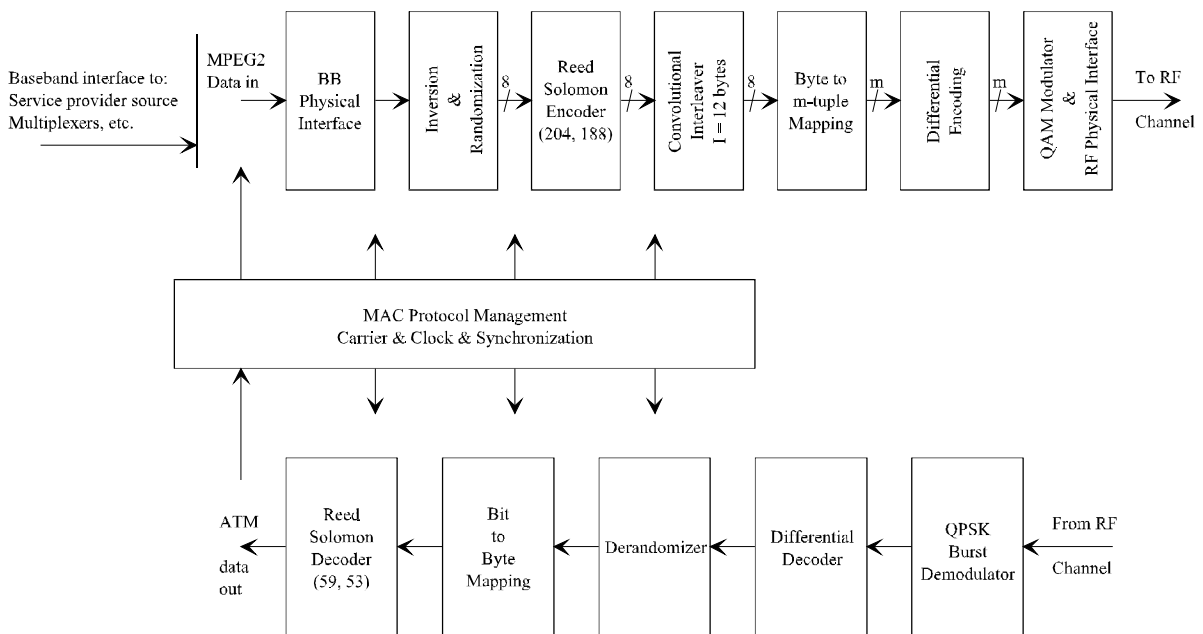

Figure 7: Conceptual Block Diagram for the IB Head-End Transceiver

### 5.2.1 Forward Interaction Path (Downstream OOB)

#### 5.2.1.1 Frequency Range (Downstream OOB)

Refer to clause 5.1.2.

### 5.2.1.2 Modulation and Mapping (Downstream OOB)

QPSK modulation is used as a means of encoding digital information over wire line or fiber transmission links. The method is a subset of Phase Shift Keying (PSK) which is a subset of Phase Modulation (PM). Specifically QPSK is a four level use of digital phase modulation (PM). Quadrature signal representations involve expressing an arbitrary phase sinusoidal waveform as a linear combination of a cosine wave and a sine wave with zero starting phases.

QPSK systems require the use of differential encoding and corresponding differential detection. This is a result of the receivers having no method of determining if a recovered reference is a sine reference or a cosine reference. In addition, the polarity of the recovered reference is uncertain.

Differential encoding transmits the information in encoded phase differences between the two successive signals. The modulator processes the digital binary symbols to achieve differential encoding and then transmits the absolute phases. The differential encoding is implemented at the digital level.

The differential encoder shall accept bits A, B in sequence, and generate phase changes as shown in Table 1.

**Table 1: Phase changes associated with bit A, B**

A	B	Phase Change
0	0	none
0	1	+90°
1	1	180°
1	0	-90°

In serial mode, A arrives first. The outputs I, Q from the differential encoder map to the phase states as in Figure 8.

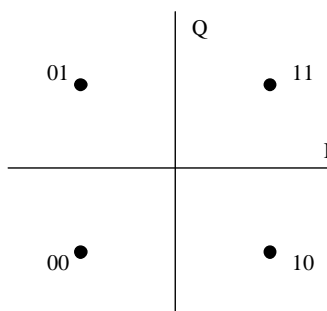

**Figure 8: Mapping for the QPSK constellation (downstream OOB)**

The phase changes can also be expressed by the following formulas (assuming the constellation is mapped from I and Q as shown above):

$$\begin{cases} A_k = \overline{(I_{k-1} \oplus Q_{k-1})} \times (Q_{k-1} \oplus Q_k) + \overline{(I_k \oplus Q_{k-1})} \times (I_k \oplus I_{k-1}) \\ B_k = (I_{k-1} \oplus Q_{k-1}) \times (I_{k-1} \oplus I_k) + (I_{k-1} \oplus Q_k) \times (Q_k \oplus Q_{k-1}) \end{cases}$$

where k is the time index.

I/Q amplitude imbalance shall be less than 1,0 dB, and phase imbalance less than 2,0°.

### 5.2.1.3 Shaping Filter (Downstream OOB)

The time-domain response of a square-root raised-cosine pulse with excess bandwidth parameter  $\alpha$  is given by:

$$g(t) = \frac{\sin\left[\frac{\pi}{T}(1-\alpha)\right] + \frac{4\alpha}{T} \cos\left[\frac{\pi}{T}(1+\alpha)\right]}{\frac{\pi}{T}\left[1 - \left(\frac{4\alpha}{T}\right)^2\right]}$$

where T is the symbol period.

The output signal shall be defined as:

$$S(t) = \sum_n [I_n \times g(t - nT) \times \cos(2\pi f_c t) - Q_n \times g(t - nT) \times \sin(2\pi f_c t)]$$

with  $I_n$  and  $Q_n$  equal to  $\pm 1$ , independently from each other, and  $f_c$  the QPSK modulator's carrier frequency.

The QPSK modulator divides the incoming bit stream so that bits are sent alternately to the in-phase modulator I and the out-of-phase modulator Q. These same bit streams appear at the output of the respective phase detectors in the demodulator where they are interleaved back into a serial bit stream.

The occupied bandwidth of a QPSK signal is given by the equation:

$$\text{Bandwidth} = \frac{f_b}{2} (1 + \alpha)$$

$f_b$  = bit rate

Symbol Rate  $f_s = f_b/2$

Nyquist Frequency  $f_N = f_s/2$

$\alpha$  = excess bandwidth = 0,30

The Power Spectrum at the transmitter shall comply to the Power Spectrum Mask given in Table 2 and Figure 9. The Power Spectrum Mask shall be applied symmetrically around the carrier frequency.

**Table 2: QPSK Downstream Transmitter Power Spectrum**

$ (f - f_c)/f_N $	Power Spectrum
$\leq 1 - \alpha$	$0 \pm 0,25$ dB
at 1	$-3 \pm 0,25$ dB
at $1 + \alpha$	$\leq -21$ dB
$\geq 2$	$\leq -40$ dB

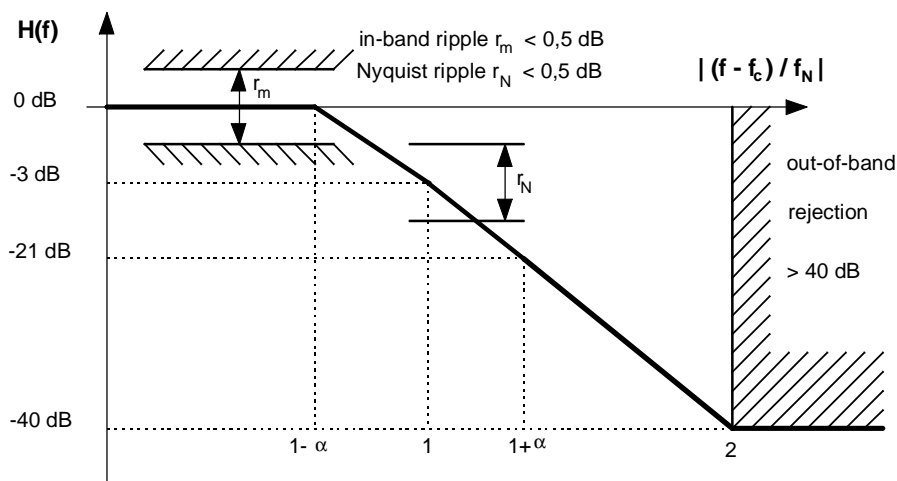

**Figure 9: QPSK Downstream Transmitter Power Spectrum**

Systems require the use of differential encoding and corresponding differential detection. This is a result of the receivers having no method of determining if a recovered reference is a sine reference or a cosine reference. In addition, the polarity of the recovered reference is uncertain.

Differential encoding transmits the information in encoded phase differences between the two successive signals. The modulator processes the digital binary symbols to achieve differential encoding and then transmits the absolute phases. The differential encoding is implemented at the digital level.

#### 5.2.1.4 Randomizer (Downstream OOB)

After addition of the FEC bytes (see clause 5.3.1), all of the 1,544 Mbit/s (or 3,088 Mbit/s) data is passed through a six register linear feedback shift register (LFSR) randomizer to ensure a random distribution of ones and zeroes. The output of the randomizer shall be the quotient of the input data multiplied by  $x^6$  and then divided by the generator polynomial  $x^6 + x^5 + 1$ . Byte/serial conversion shall be MSB first. A complementary self-synchronizing de-randomizer is used in the receiver to recover the data.

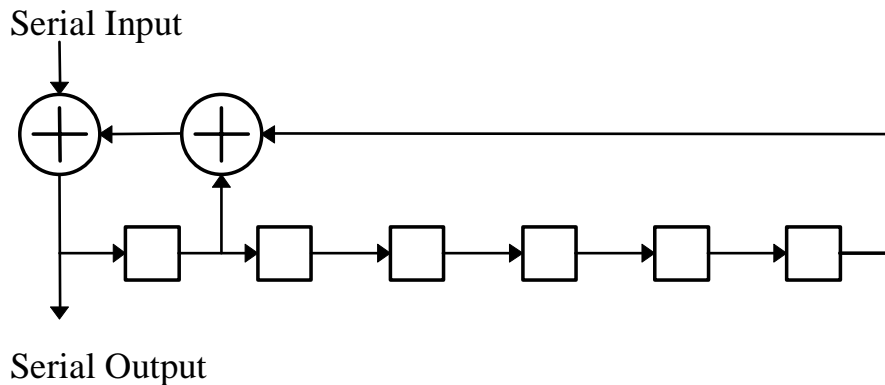

Figure 10: Example randomizer

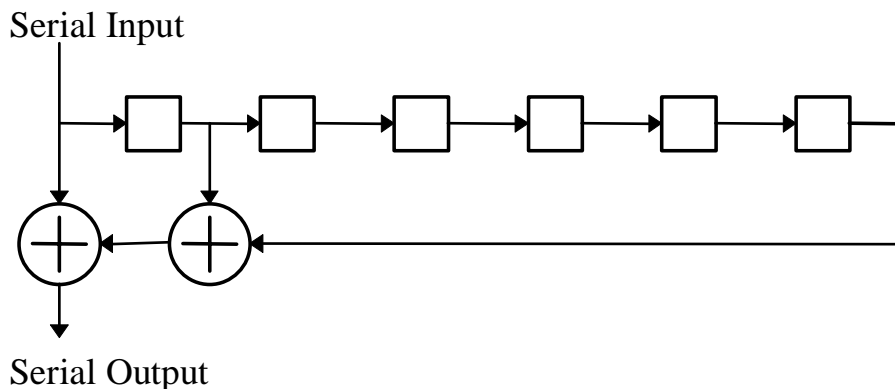

Figure 11: Example de-randomizer

#### 5.2.1.5 Bit Rate (Downstream OOB)

The bit rate (BR) shall be 1,544 Mbit/s or 3,088 Mbit/s. The support of 3,088 Mbit/s is mandatory, of 1,544 Mbit/s is optional for both INA and NIU. Symbol rate accuracy should be within  $\pm 50$  ppm.

#### 5.2.1.6 Receiver power level (Downstream OOB)

The receiver power level shall be in the range 42 dB  $\mu$ V- 75 dB  $\mu$ V (RMS) (75  $\Omega$ ) at its input.

### 5.2.1.7 Summary (Downstream OOB)

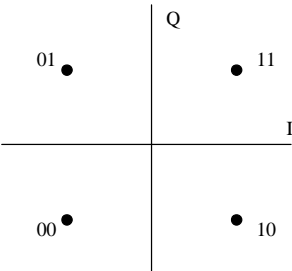
Transmission Rate	1,544 Mbit/s for Grade A (optional for INA and NIU) 3,088 Mbit/s for Grade B (mandatory for INA and NIU)
Modulation	Differentially encoded QPSK
Transmit Filtering	Filtering is $\alpha = 0,30$ square root raised cosine
Channel Spacing	1 MHz for Grade A 2 MHz for Grade B
Frequency Step Size	250 kHz (center frequency granularity)
Randomization	After addition of the FEC bytes, all of the 1,544 Mbit/s (or 3,088 Mbit/s) data is passed through a six register linear feedback shift register (LFSR) randomizer to ensure a random distribution of ones and zeroes. The generating polynomial is: $x^6 + x^5 + 1$ . Byte/serial conversion shall be MSB first. A complementary self-synchronizing de-randomizer is used in the receiver to recover the data.
Differential Encoding	The differential encoder shall accept bits A, B in sequence, and generate phase changes as follows: A B Phase Change 0 0 none 0 1 +90° 1 1 180° 1 0 -90° In serial mode, A arrives first.
Signal Constellation	The outputs I, Q from the differential encoder map to the phase states as in Figure 12.  <b>Figure 12: QPSK Constellation</b>
Frequency Range	recommended but not mandatory 70 MHz to 130 MHz and/or 300 MHz to 862 MHz
Frequency Stability	$\pm 50$ ppm measured at the upper limit of the frequency range
Symbol Rate Accuracy	$\pm 50$ ppm
Carrier Suppression	> 30 dB
I/Q Amplitude Imbalance	< 1,0 dB
I/Q Phase Imbalance	< 2,0°
Receive Power Level at the NIU input	42 - 75 dB $\mu$ V (RMS) (75 $\Omega$ )
Transmit Spectral Mask	A common mask for both bit rates: 1,544 Mbit/s (Grade A) and 3,088 Mbit/s (Grade B) is given in Table 2 and Figure 9.

### 5.2.1.8 Bit Error Rate Downstream OOB (Informative)

Bit error rate at the NIU should be less than  $10^{-10}$  (after error correction, i.e. 1 error in 2 hours at 1,5 Mbit/s) at  $C/N > 20$  dB for downstream transmission.  $C/N$  is the carrier-to-noise ratio relevant for the demodulation process (Nyquist bandwidth for white noise).

### 5.2.2 Forward Interaction Path (Downstream IB)

The IB Forward Interaction Path shall use a MPEG-2 TS stream with a modulated QAM channel as defined by EN 300 429 [7]. Frequency range, channel spacing, and other lower physical layer parameters should follow that specification. The accuracy of the downstream frequency shall be  $\pm 50$  ppm.

### 5.2.3 Return Interaction Path (Upstream)

The upstream path allows two types of modulation - QPSK and 16QAM. Every upstream channel will use a single modulation type - QPSK or 16QAM.

#### 5.2.3.1 Frequency Range (Upstream)

The frequency range is not specified as mandatory although a guideline is provided to use the 5 MHz to 65 MHz. Frequency stability shall be in the range  $\pm 50$  ppm measured at the upper limit of the frequency range.

#### 5.2.3.2 Modulation and Mapping (Upstream)

The input bits will be mapped into I/Q constellations according to the following:

QPSK symbols -  $I_1 Q_1$

16QAM symbols -  $I_1 Q_1 I_0 Q_0$

Where  $I_1$  is the MSB for QPSK/16QAM

$Q_1$  is the LSB for QPSK

$Q_0$  is the LSB for 16QAM.

The MSB must be the first bit of the serial data into the modulator.

The unique word (CC CC CC 0D for QPSK and F3 F3 F3 F3 F3 F3 33 F7 for 16QAM, see clause 5.3.3 for upstream framing) is not differentially encoded. For the remainder of the slot, the coding will be differential. The QPSK symbol map and 16QAM symbol map for the unique word are described in Figure 13 and Figure 14.

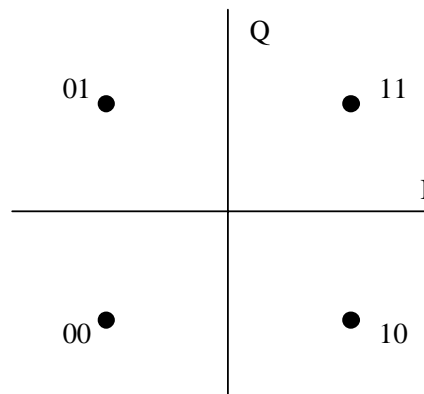

Figure 13: Mapping for the QPSK constellation (upstream)

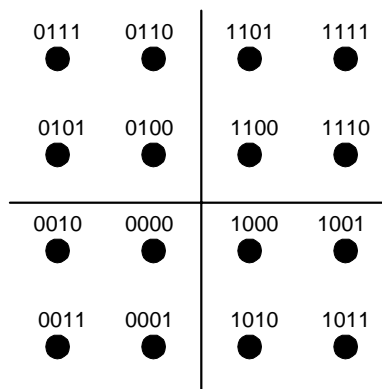

Figure 14: Mapping for the 16QAM constellation (upstream)

The differential encoding shall be done according to Table 3. The current transmitted quadrant is derived from the previous transmitted quadrant and the current input bits.

**Table 3: Differential Encoding**

Current input bits I <sub>1</sub> Q <sub>1</sub>	Quadrant phase change	MSBs of the previous transmitted symbol	MSBs of the currently transmitted symbol
00	0°	11	11
00	0°	01	01
00	0°	00	00
00	0°	10	10
01	90°	11	01
01	90°	01	00
01	90°	00	10
01	90°	10	11
11	180°	11	00
11	180°	01	10
11	180°	00	11
11	180°	10	01
10	270°	11	10
10	270°	01	11
10	270°	00	01
10	270°	10	00

I/Q amplitude imbalance shall be less than 1,0 dB, and phase imbalance less than 2,0°.

### 5.2.3.3 Shaping Filter (Upstream)

The time-domain response of a square-root raised-cosine pulse with excess bandwidth parameter  $\alpha$  is given by:

$$g(t) = \frac{\sin[\frac{\pi}{T}(1-\alpha)] + \frac{4\alpha}{T} \cos[\frac{\pi}{T}(1+\alpha)]}{\frac{\pi}{T} [1 - (\frac{4\alpha}{T})^2]}$$

where T is the symbol period.

The output signal shall be defined as:

$$S(t) = \sum_n [I_n \times g(t-nT) \times \cos(2\pi f_c t) - Q_n \times g(t-nT) \times \sin(2\pi f_c t)]$$

with I<sub>n</sub> and Q<sub>n</sub> equal to  $\pm 1$  (QPSK)/ $\pm 3$  (16QAM), independently from each other, and f<sub>c</sub> the QPSK/16QAM modulator's carrier frequency.

The QPSK /16QAM modulator divides the incoming bit stream so that bits are sent alternately to the in-phase modulator I and the out-of-phase modulator Q. These same bit streams appear at the output of the respective phase detectors in the demodulator where they are interleaved back into a serial bit stream.

The QPSK /16QAM signal parameters are:

$$\text{RF bandwidth} = \frac{f_b}{2}(1+\alpha)$$

$$\text{Occupied RF Spectrum} \quad [f_c - f_s/2, f_c + f_s/2]$$

$$\text{Symbol Rate} \quad f_s = f_b/2$$

Nyquist Frequency  $f_N = f_s/2$

with  $f_b$  = bit rate,  $f_c$  = carrier frequency and  $\alpha$  = excess bandwidth.

For all 8 channel types: 256 kbit/s QPSK (Grade A), 512 kbit/s 16QAM (Grade AQ), 1,544 Mbit/s QPSK (Grade B), 3,088 Mbit/s 16QAM (Grade BQ), 3,088 Mbit/s QPSK (Grade C), 6,176 Mbit/s 16QAM (Grade CQ), 6,176 Mbit/s QPSK (Grade D) and 12,352 Mbit/s 16QAM (Grade DQ), the Power Spectrum at the transmitter shall comply to the Power Spectrum Mask given in Table 4 and Figure 15. The Power Spectrum Mask shall be applied symmetrically around the carrier frequency.

**Table 4: Upstream Transmitter Power Spectrum**

$ (f - f_c)/f_N $	Power Spectrum
$\leq 1-\alpha$	$0 \pm 0,25$ dB
at 1	$-3 \pm 0,25$ dB
at $1+\alpha$	$\leq -21$ dB
$\geq 2$	$\leq -40$ dB

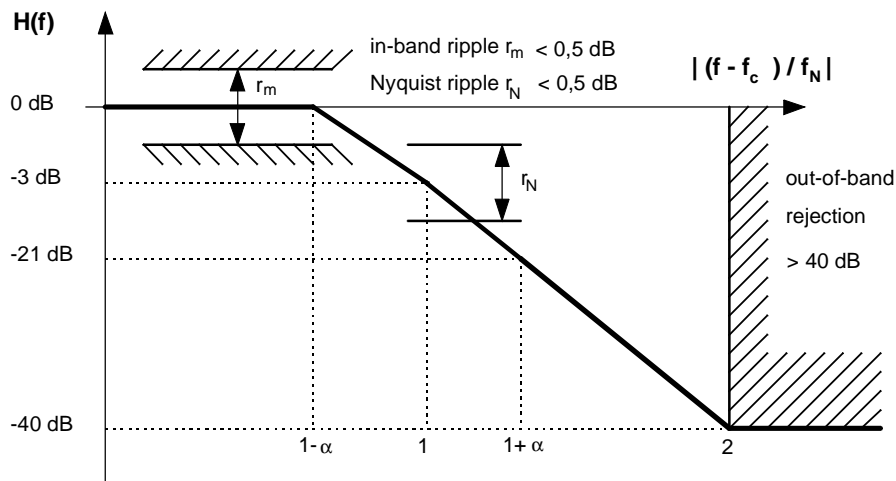

**Figure 15: Upstream Transmitter Power Spectrum**

The specifications which shall apply to modulation for the upstream channel are given in Table 4.

#### 5.2.3.4 Randomizer (Upstream)

The unique word shall be sent in clear (see clause 5.3.3). After addition of the FEC bytes, randomization shall apply only to the payload area and FEC bytes, with the randomizer performing modulo-2 addition of the data with a pseudo-random sequence. The generating polynomial is  $x^6 + x^5 + 1$  with seed all ones. We assume the first value coming out of the pseudo-random generator taken into account is 0. Byte/serial conversion shall be MSB first. The binary sequence generated by the shift register starts with 00000100.... The first "0" is to be added in the first bit after the unique word.

A complementary non self-synchronizing de-randomizer is used in the receiver to recover the data. The de-randomizer shall be enabled after detection of the unique word.



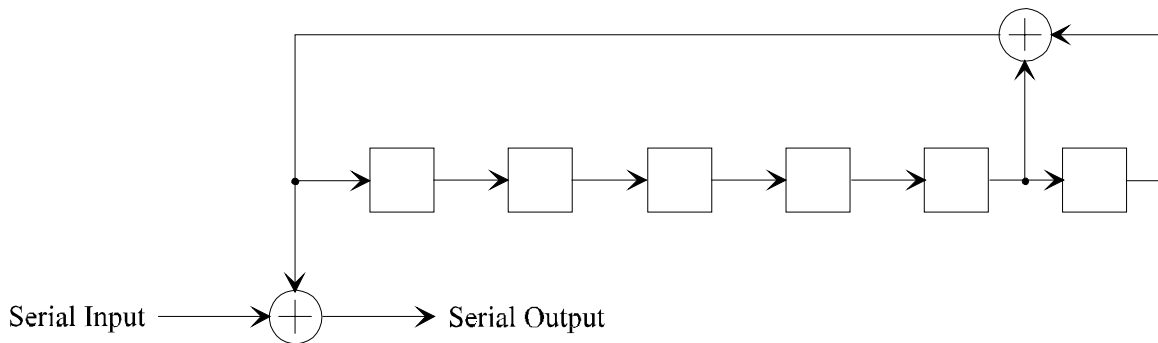

Figure 16: Randomizer

### 5.2.3.5 Pre Equalizer

In the case of 16QAM modulation, the NIU is responsible for configuring a transmit pre equalizer according to messages received from the INA. The pre equalizer will be a T-spaced equalizer with 8 taps. The taps coefficient real and imaginary parts will consist of 16 bit, coded in fractional two's complement notation: S1.14 (signed bit, integer bit, binary point, 14 fractional bits).

EXAMPLE:  $+1,875 = 30\,720/2^{14} = 0 \times 7\,800$

$-1,875 = -30\,720/2^{14} = 0 \times 8\,800$

The pre equalizer will be configured during the ranging and power calibration phase. In the case of the first sign on the service channel, the calculation will be based on the QPSK symbols that are sent (by the NIU) in the <MAC> sign on response message (see clause 5.5.4.2). To ensure proper calculation, the NIU should ensure that the slot containing the <MAC> sign on response message would be sent with at least 200 different QPSK symbols (regardless of the message length in bytes). In the case of reprovision to a 16QAM channel, the coefficients will be calculated according to 16QAM symbols.

Before initial ranging and calibration (at first sign on or in the case of a new upstream channel), the NIU MUST initiate the coefficients to 1 (center tap) and 0.

### 5.2.3.6 Bit Rate (Upstream)

Eight grades of modulation and transmission rate are specified:

**Table 5: Upstream bit-rates and modulations for modulation grades A, AQ, B, BQ, C, CQ, D and DQ**

Grade	Rate
A	256 kbit/s QPSK (optional for INA and NIU)
B	1,544 Mbit/s QPSK (optional for INA and NIU)
C	3,088 Mbit/s QPSK (mandatory for INA and NIU)
D	6,176 Mbit/s QPSK (optional for INA and NIU)
AQ	512 kbit/s 16QAM (optional for INA and NIU)
BQ	3,088 Mbit/s 16QAM (optional for INA and NIU)
CQ	6,176 Mbit/s 16QAM (optional for INA and NIU)
DQ	12,352 Mbit/s 16QAM (optional for INA and NIU)

The support of 3,088 Mbit/s QPSK is mandatory, of other combinations of modulation and rate is optional for both INA and NIU.

Symbol rate accuracy should be within  $\pm 50$  ppm.

For grades A and AQ, the rate is 500 slots/s. For grades B and BQ, the rate is 3 000 slots/s. For grades C and CQ, the rate is 6 000 slots/s. For grades D and DQ, the rate is 12 000 slots/s.

### 5.2.3.7 Transmit Power Level (Upstream)

At the output, the transmit power level shall be in the range 85 - 113 dB $\mu$ V (RMS) (75  $\Omega$ ). In some geographic areas, it may be necessary to cover the range 85-122 dB $\mu$ V (RMS) (75  $\Omega$ ). However, note that high power may lead to electromagnetic compatibility problems. This power shall be adjustable by steps of 0,5 dB (nominally) by MAC messages coming from the INA.

Measured at the INA, the US power accuracy shall be better or equal to  $\pm 1,5$  dB.

### 5.2.3.8 Upstream Burst Power and Timing Profiles

Because of the symbol shaping filter that spreads the symbol duration over  $T_s = 1/\text{symbol\_rate}$ , a burst has a ramp up (before the first symbol) and a ramp down (after the last symbol) as shown in Figure 17.

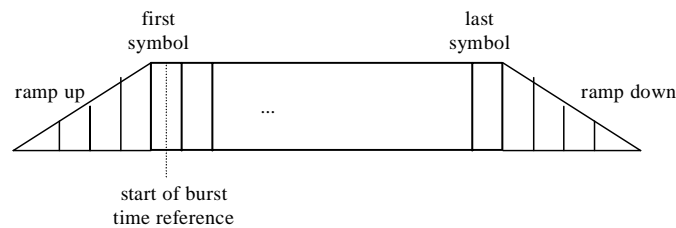

**Figure 17: Burst ramp up and down**

The ramps up and down of consecutive bursts can overlap.

The ramps shall be minimum 3 symbols long.

When the transmitter is idle the upstream power level attenuation shall be more than 60 dB (relative to the nominal burst power output level), over the entire power output range (The absolute maximum output power level should not exceed that specified in Table 7). A terminal is considered to be idle if it is 3 slots before an imminent transmission or 3 slots after its most recent transmission.

4 symbols before the first symbol of a burst and 4 symbols after the last symbol, the upstream power level attenuation shall be more than 30 dB (relative to the nominal burst power output level), over the entire power output range.

After ranging and propagation delay compensation, the NIU/STB US timing accuracy shall be better than or equal to  $\pm 5/8^{\text{th}}$  of a symbol (Upstream rate).

The time ranging accuracy provided by the MAC messages coming from the INA shall be better than or equal to  $\pm 1/8^{\text{th}}$  of a symbol (upstream rate) or  $\pm 50$  ns, whatever is the maximum (because the ranging unit is 100 ns).

The NIU messages shall then arrive at the INA in a window of  $\pm 0,75$  symbols (upstream transmission bit rate) for bit rates of 256 kbit/s, 1,544 Mbit/s and 3,088 Mbit/s and in a window of  $\pm 0,78$  symbols (upstream transmission bit rate) for the 6,176 Mbit/s case.

### 5.2.3.9 Interference (Spurious) Suppression.

The noise and the spurious power at the output of the transmitting (upstream) device may not exceed the levels as shown in Table 6. The measurement bandwidth is equal to the symbol rate (e.g. 1,544 kHz for 1,544 kSymbols/s) below  $fd_1$  and equal to 7 MHz above  $fd_1$ .

**Table 6: Interference Spurious Suppression**

	<b>transmitting burst</b>	<b>between bursts</b>
<b>In band</b>	n.a.	-60 dBc (see notes 1 and 2)
<b>Adjacent band upstream</b>	-40 dBc	-70 dBc (see notes 1 and 2)
<b>Other band within 5 MHz ... <math>fd_1</math> MHz</b>	-40 dBc	-70 dBc (see note 1)
<b><math>fd_1</math> ... <math>fd_2</math> MHz (measured in 7 MHz)</b>	45 dB $\mu$ V	22 dB $\mu$ V
<b>&gt; <math>fd_2</math> MHz (measured in 7 MHz)</b>	30 dB $\mu$ V	22 dB $\mu$ V
NOTE 1: dBc is based on the carrier level during the burst.		
NOTE 2: The additional suppression of 30 dB for inter burst is based on the connection max. 1000 NIUs' per INA.		
fd1 = minimum downstream frequency in the network.		
fd2 = minimum downstream frequency occupied by TV programs = min.		

## 5.2.3.10 Summary (Upstream)

Table 7: Summary (Upstream)

Upstream Transmission Bit Rate	<p>Eight grades of modulation and transmission bit rate are specified:</p> <table border="0"> <tr><td>Grade</td><td>Rate</td></tr> <tr><td>A</td><td>256 kbit/s QPSK (optional for INA and NIU)</td></tr> <tr><td>B</td><td>1,544 Mbit/s QPSK (optional for INA and NIU)</td></tr> <tr><td>C</td><td>3,088 Mbit/s QPSK (mandatory for INA and NIU)</td></tr> <tr><td>D</td><td>6,176 Mbit/s QPSK (optional for INA and NIU)</td></tr> <tr><td>AQ</td><td>512 kbit/s 16QAM (optional for INA and NIU)</td></tr> <tr><td>BQ</td><td>3,088 Mbit/s 16QAM (optional for INA and NIU)</td></tr> <tr><td>CQ</td><td>6,176 Mbit/s 16QAM (optional for INA and NIU)</td></tr> <tr><td>DQ</td><td>12,352 Mbit/s 16QAM (optional for INA and NIU)</td></tr> </table> <p>The support of 3,088 Mbit/s QPSK is mandatory, of other combinations of modulation and rate is optional for both INA and NIU.</p>	Grade	Rate	A	256 kbit/s QPSK (optional for INA and NIU)	B	1,544 Mbit/s QPSK (optional for INA and NIU)	C	3,088 Mbit/s QPSK (mandatory for INA and NIU)	D	6,176 Mbit/s QPSK (optional for INA and NIU)	AQ	512 kbit/s 16QAM (optional for INA and NIU)	BQ	3,088 Mbit/s 16QAM (optional for INA and NIU)	CQ	6,176 Mbit/s 16QAM (optional for INA and NIU)	DQ	12,352 Mbit/s 16QAM (optional for INA and NIU)
Grade	Rate																		
A	256 kbit/s QPSK (optional for INA and NIU)																		
B	1,544 Mbit/s QPSK (optional for INA and NIU)																		
C	3,088 Mbit/s QPSK (mandatory for INA and NIU)																		
D	6,176 Mbit/s QPSK (optional for INA and NIU)																		
AQ	512 kbit/s 16QAM (optional for INA and NIU)																		
BQ	3,088 Mbit/s 16QAM (optional for INA and NIU)																		
CQ	6,176 Mbit/s 16QAM (optional for INA and NIU)																		
DQ	12,352 Mbit/s 16QAM (optional for INA and NIU)																		
Modulation	Differentially encoded QPSK/differentially encoded 16QAM																		
Transmit Filtering	alpha = 0,30 square root raised cosine																		
Channel Spacing	200 kHz for Grades A, AQ 1 MHz for Grades B, BQ 2 MHz for Grades C, CQ 4 MHz for Grades D, DQ																		
Frequency Step Size	50 kHz																		
Randomization	<p>The unique word shall be sent in the clear. After addition of the FEC bytes, randomization shall apply only to the payload area and FEC bytes, with the randomizer performing modulo-2 addition of the data with a pseudo-random sequence. The generating polynomial is <math>x^6 + x^5 + 1</math> with seed all ones. Byte/serial conversion shall be MSB first.</p> <p>A complementary non self-synchronizing de-randomizer is used in the receiver to recover the data. The de-randomizer shall be enabled after detection of the unique word.</p>																		
Differential Encoding	The differential encoder shall accept bits $I_1 Q_1 I_0 Q_0$ in sequence, and generate phase changes as follows. In serial mode, $I_1$ arrives first. See Table 3 for details.																		
Signal Constellation QPSK	<p>The outputs I, Q from the differential encoder map to the phase states as in Figure 18.</p> <div style="text-align: center;"> </div> <p><b>Figure 18: Burst QPSK Constellation</b></p>																		
Signal Constellation 16QAM	<div style="text-align: center;"> </div> <p><b>Figure 19: Burst 16QAM Constellation</b></p>																		
Frequency Range	5 MHz to 65 MHz recommended but not mandatory.																		
Frequency Stability	±50 ppm measured at the upper limit of the frequency range																		

Symbol Rate Accuracy	±50 ppm
Transmit Spectral Mask	A common mask for all eight upstream grades is given in Table 4 and Figure 15.
Carrier Suppression when Transmitter Active	> 30 dB
Burst Power Profile	<p>Upstream power level attenuation shall be more than 60 dB relative to the nominal burst power output level over the entire power output range and 30 dB right after or before transmission.</p> <p>Idle Transmitter Definition: A terminal is considered to be idle if it is 3 slots before an imminent transmission or 3 slots after its most recent transmission.</p> <p>The diagram illustrates the burst power profile. A central horizontal line represents the nominal power level. Above this line, a 'Burst Packet' is shown, consisting of a 63-byte payload, a 1-byte overhead, and an 11-byte guard band. This burst is preceded and followed by 3 slots of idle time. The power level during these idle periods is 60 dB below the nominal level. At the start and end of the burst, the power level rises to 30 dB below the nominal level. The power level then rises to the nominal level during the burst. The power level during the burst is 30 dB above the nominal level.</p>
I/Q Amplitude Imbalance	< 1,0 dB
I/Q Phase Imbalance	< 2,0°
Transmit Power Level at the modulator output (upstream)	85-113 dBμV (RMS) (75 Ω) . In some geographic areas, it may be necessary to cover the range 85-122 dBμV (RMS) (75 Ω). In any case, cable networks shall comply with the EMC requirements of CENELEC EN 50083-2 [19] concerning radiated disturbance power by feed in of the transmit power.

### 5.2.3.11 Packet loss Upstream (Informative)

Upstream packet loss at the INA shall be less than  $10^{-6}$  at  $C/N > 20$  dB (after error correction) for upstream transmission.

NOTE: An upstream packet loss occurs when one or more bit per upstream packet (after error correction) are uncorrectable. The  $C/N$  is referred at the demodulator input (Nyquist bandwidth, white noise).

### 5.2.3.12 Maximum Cable Delay

This specification has been designed to support cable round trip delays of up to 800 μs, which corresponds to a cable length of approximately 80 km. Larger delays than this may be accommodated, with judicious use of the specification.

## 5.3 Framing

### 5.3.1 Forward Interaction Path (Downstream OOB)

#### 5.3.1.1 Signalling Link Extended Superframe Framing Format

The Signalling Link Extended Superframe (SL-ESF) frame structure is shown in Figure 20. The bitstream is partitioned into 4 632-bit Extended Superframes. Each Extended Superframe consists of  $24 \times 193$ -bit frames. Each frame consists of 1 overhead (OH) bit and 24 bytes (192 bits) of payload.

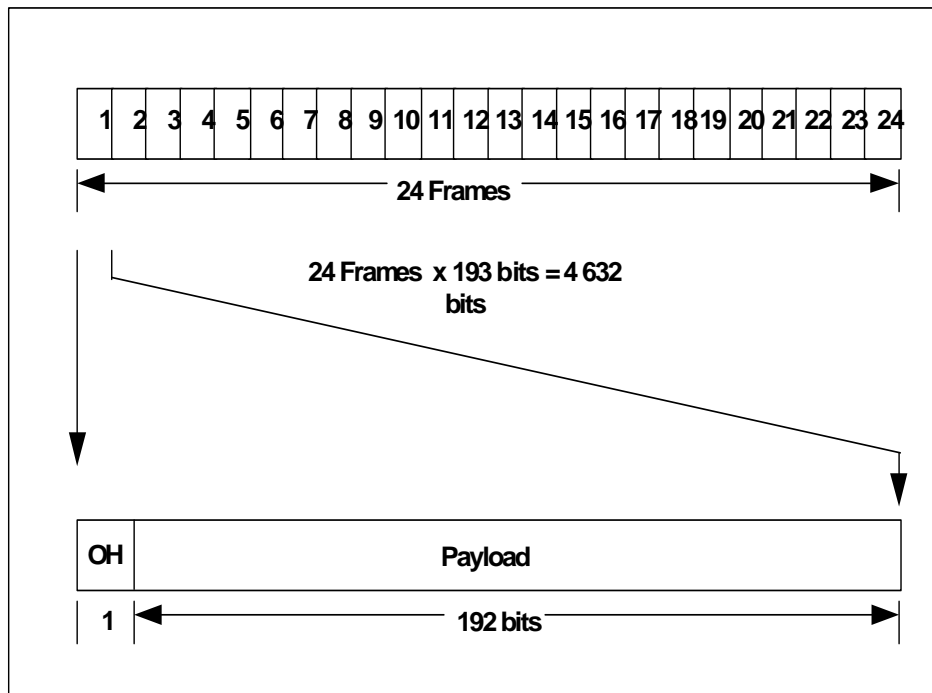

Figure 20: SL-ESF Frame Structure

### 5.3.1.2 Frame overhead

There are 24 frame overhead bits in the Extended Superframe which are divided into Extended Superframe Frame Alignment Signal (F1-F6), Cyclic Redundancy Check (C1-C6), and M-bit Data Link (M1-M12) as shown in Table 8. Bit number 0 is received first.

Table 8: Frame overhead

Frame Number	Bit Number	Overhead Bit	Data (192 bits)
1	0	<b>M1</b>	
2	193	C1	
3	386	M2	
4	579	F1 = 0	
5	772	M3	
6	965	C2	
7	1 158	M4	
8	1 351	F2 = 0	
9	1 544	<b>M5</b>	
10	1 737	C3	
11	1 930	M6	
12	2 123	F3 = 1	
13	2 316	M7	
14	2 509	C4	
15	2 702	M8	
16	2 895	F4 = 0	
17	3 088	<b>M9</b>	
18	3 281	C5	
19	3 474	M10	
20	3 667	F5 = 1	
21	3 860	M11	
22	4 053	C6	
23	4 246	M12	
24	4 439	F6 = 1	

FAS: Frame Alignment Signal (F1 - F6).  
DL: Mbit Data Link (M1 - M12).  
CRC: Cyclic Redundancy Check (C1 - C6).

### ESF Frame Alignment Signal

The ESF Frame Alignment Signal (FAS) is used to locate all 24 frames and overhead bit positions. The bit values of the FAS are defined as follows:

$$F1 = 0, F2 = 0, F3 = 1, F4 = 0, F5 = 1, F6 = 1.$$

### ESF Cyclic Redundancy Check

The Cyclic Redundancy Check field contains the CRC-6 check bits calculated over the previous Extended Superframe (CRC Message block [CMB] size = 4 632 bits). Before calculation, all 24 frame overhead bits are equal to "1". All information in the other bit positions is unchanged. The check bit sequence C1-C6 is the remainder after multiplication by  $x^6$  and then division by the generator polynomial  $x^6 + x + 1$  of the CMB. C1 is the most significant bit of the remainder. The initial remainder value is preset to all zeros.

### ESF Mbit Data Link

The M-bits in the SL-ESF serve for slot timing assignment (see clause 5.4).

#### 5.3.1.3 Payload Structure

The SL-ESF frame payload structure provides a known container for defining the location of the ATM cells and the corresponding Reed Solomon parity values. The SL-ESF payload structure is shown in Table 9. When the INA has no data or MAC messages to send on the downstream OOB channel, it will send Idle ATM Cells as specified in [16], where the content of the Idle ATM Cell has been specified as:

0x00, 0x00, 0x00, 0x01, 0x52 (Idle ATM Cell header)

0x6A, 0x6A, ..., 0x6A (48 data bytes payload)

**Table 9: ESF Payload structure**

	2		53			2	
1	R1a	R1b	ATM Cell			RS parity	
2	R1c	R2a				R2 b	
3	R2c	R3a					
4	R3b	R3c				R4 a	
5	R4b	R4c					
6	R5a	R5b				R5 c	
7	R6a	R6b					
8	R6c	R7a				R7 b	
9	R7c	R8a					
10	R8b	R8c				T T	

The SL-ESF payload structure consists of 5 rows of 57 bytes each, 4 rows of 58 bytes each which includes 1 byte trailer, and 1 row of 59 bytes, which includes a 2 byte trailer. The relative ordering of data between Table 9 and Table 8, is such that reading Table 9 from left to right, and then top to bottom, corresponds to reading Table 8 from top to bottom. The most significant bit of byte R1a in Table 9, corresponds to Bit Number 1 in Table 8. The various SL-ESF payload fields are described below.

Define the downstream time-ticks  $T_{dn}$  and the upstream time-ticks  $T_{un}$  as follows.

The downstream channel is divided into 3 ms periods separated by downstream time-ticks  $T_{dn}$  and the upstream channel is divided into 3 ms periods separated by upstream time ticks  $T_{un}$  in case of upstream transmission bit rates of 1,544 Mbit/s, 3,088 Mbit/s and 6,176 Mbit/s... In case of an upstream transmission bit rate of 256 kbit/s both downstream and upstream periods are 6 ms.

Then the time difference,  $T_{un}-T_{dn}$ , is called the *Absolute\_Time\_Offset*, and is defined:

$$\text{Absolute\_Time\_Offset} = T_{un}-T_{dn}$$

And:

$$\text{New Absolute\_Time\_Offset} = \text{current Absolute\_Time\_Offset} - \text{Time\_Offset\_Value}$$

(*Time\_Offset\_Value* is a field contained in the <MAC> Ranging And Power Calibration Message and is defined in clause 5.5.4.3).

Before the NIU is going through the sign-on procedure for the first time, the current *Absolute\_Time\_Offset* is set according to the value passed in the Default Configuration message (taking into account the timing accuracies).

The NIU shall use the following definitions for using the R-bytes:

- the boundary information contained in the downstream period that starts by downstream time-tick  $T_{dn}$  relates to the slots in the upstream period that starts at upstream time-tick  $T_{un+1}$ . This upstream period is also called the "next" one;
- the reception information contained in the downstream period that starts by downstream time-tick  $T_{dn}$  relates to the slots in the upstream period that starts at upstream time-tick  $T_{un-2}$ . This upstream period is also called the "second previous" one.

### ATM Cell Structure

The format for each ATM cell structure is shown in Figure 21. This structure and field coding shall be consistent with the structure and coding given in ITU-T Recommendation I.361 [1] for ATM UNI.

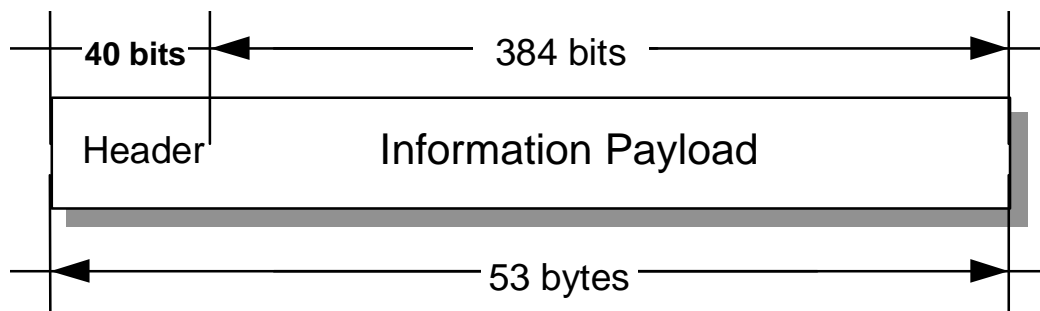

**Figure 21: ATM cell format**

The entire header (including the HEC byte) shall be protected by the Header Error Control (HEC) sequence. The HEC code shall be contained in the last byte of the ATM header. The HEC sequence shall be capable of:

- single-bit error correction;
- multiple-bit error detection.

Error detection in the ATM header shall be implemented as defined in [16]. The HEC byte shall be generated as described in [16], including the recommended modulo-2 addition (XOR) of the pattern 01010101b to the HEC bits. The generator polynomial coefficient set used and the HEC sequence generation procedure shall be in accordance with [16].

### Channel coding and interleaving

Reed-Solomon encoding with  $t = 1$  shall be performed on each ATM cell. This means that 1 erroneous byte per ATM cell can be corrected. This process adds 2 parity bytes to the ATM cell to give a codeword of (55,53).



The Reed-Solomon code shall have the following generator polynomials:

**Code Generator Polynomial:**  $g(x) = (x + \mu^0)(x + \mu^1)$ , where  $\mu = 02$  hex

**Field Generator Polynomial:**  $p(x) = x^8 + x^4 + x^3 + x^2 + 1$

The shortened Reed-Solomon Code shall be implemented by appending 200 bytes, all set to zero, before the information bytes at the input of a (255,253) encoder; after the coding procedure these bytes are discarded.

Convolutional interleaving shall be applied to the ATM cells contained in the SL-ESF. The Rxa - Rxc bytes and the two T bytes shall not be included in the interleaving process. Convolutional interleaving is applied by interleaving 5 lines of 55 bytes.

Following the scheme of Figure 22, convolutional interleaving shall be applied to the error protected packets. The convolutional interleaving process shall be based on the Forney approach, which is compatible with the Ramsey type III approach, with  $I = 5$ . The Interleaved frame shall be composed of overlapping error protected packets and a group of 10 packets shall be delimited by the start of the SL-ESF.

The interleaver is composed of  $I$  branches, cyclically connected to the input byte-stream by the input switch. Each branch shall be a First In First Out (FIFO) shift register, with depth  $(M \times j)$  cells (where  $M = N/I$ ,  $N = 55 =$  error protected frame length,  $I =$  interleaving depth,  $j =$  branch index). The input and output switches shall be synchronized. Each cell of the FIFO shall contain one byte.

For synchronization purposes, the first byte of each error protected packet shall be always routed into the branch "0" of the interleaver (corresponding to a null delay). The third byte of the SL-ESF payload (the byte immediately following R1b) shall be aligned to the first byte of an error protected packet.

The de-interleaver is similar, in principle, to the interleaver, but the branch indexes are reversed (i.e. branch 0 corresponds to the largest delay). The de-interleaver synchronization is achieved by routing the third data byte of the SL-ESF into the "0" branch.

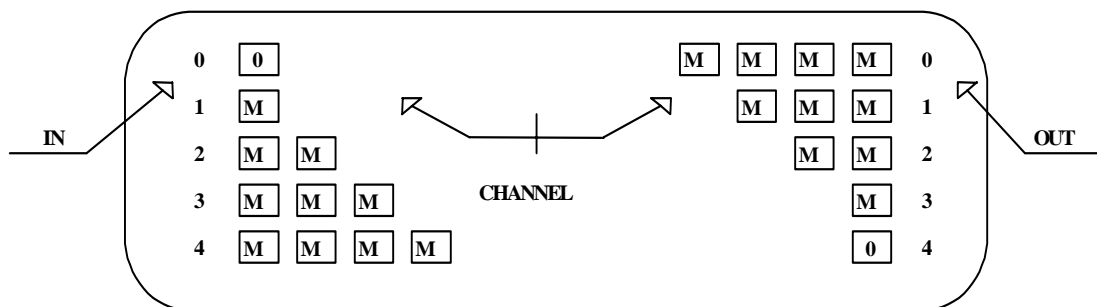

**Figure 22: Interleaver and de-interleaver structures**

### Reception indicator fields and slot boundary fields

A downstream channel can control up to 8 upstream channels and contains control information for each of its associated upstream channels. This information is contained within structures known as Flags. A set of Flags is represented by either 24 bits (denoted b0...b23) or by 3 bytes (denoted Rxa, Rxb and Rxc):

Rxa = (b0 ...b7) = (msb...lsb)

Rxb = (b8...b15) = (msb...lsb)

Rxc = (b16...b23) = (msb...lsb)

One or more consecutive MAC flags are associated to one upstream channel. This link is done in the MAC messages Default Configuration Message, Connect Message, Reprovision Message and Transmission Control Message. To the upstream channel "c" (parameter Service\_Channel or Upstream\_Channel\_Number or New\_Upstream\_Channel\_Number of the MAC messages mentioned above) are associated the MAC flags "x" and the following as described below. "x" corresponds to the parameter MAC\_Flag\_Set of the previous MAC messages. It is a 5 bit field and can take the values 1... 16. Values 0 and 17...31 are invalid.

In the OOB downstream case, each frame structure contains eight sets of Flags represented by  $R_{x_a}$ ,  $R_{x_b}$  and  $R_{x_c}$ , where  $x$  is replaced by the numbers 1...8. In the case of a 1,544 Mbit/s downstream bit rate, only one frame occurs during a 3 ms interval providing 8 sets of Flags. In the case of a 3,088 Mbit/s downstream bit rate, two frames A and B occur during a 3 ms interval, providing 16 sets of Flags. The second set of Flags (contained in - B) are denoted by  $R_{x_a}$ ,  $R_{x_b}$  and  $R_{x_c}$ , where  $x$  is replaced by the numbers 9 through 16.

In case of a 3,088 Mbit/s upstream channel, two sets of Flags are required. In this case, the `MAC_Flag_Set` parameter represents the first of two successively assigned Flag sets ( $R_{x_a}$ - $R_{x_c}$ ,  $R_{y_a}$ - $R_{y_c}$  with  $y = (x+1)$  with  $x$  belongs to [1, 7] for 1,544 Mbit/s DS and belongs to [1, 15] for 3,088 Mbit/s DS. In particular, if one downstream OOB 1,544 Mbit/s channel controls 3,088 Mbit/s upstream channels, at most 4 upstream channels can be controlled, due to the number of available Flags.

In case of a 6,176 Mbit/s upstream channel, four sets of Flags are required. In this case, the `MAC_Flag_Set` parameter represents the first of four successively assigned Flag sets ( $R_{x_a}$ - $R_{x_c}$ ,  $R_{u_a}$ - $R_{u_c}$ ,  $R_{v_a}$ - $R_{v_c}$ ,  $R_{w_a}$ - $R_{w_c}$  with  $u = (x+1)$ ,  $v = (x+2)$ ,  $w = (x+3)$ , with  $x$  belongs to [1, 5] for 1,544 Mbit/s DS and belongs to [1, 13] for 3,088 Mbit/s DS. In particular, if one downstream OOB 3,088 Mbit/s channel controls 6,176 Mbit/s upstream channels, at most 4 upstream channels can be controlled, due to the number of available Flags. And if one downstream OOB 1,544 Mbit/s channel controls 6,176 Mbit/s upstream channels, at most 2 upstream channels can be controlled.

The bits  $b_0$  to  $b_{23}$  are defined as follows:

- $b_0$  = ranging slot indicator for next 3 ms period (msb)  
(6 ms for 256 kbit/s)
- $b_1$ - $b_6$  = slot boundary definition field for next 3 ms period  
(6 ms for 256 kbit/s )
- $b_7$  = slot 1 reception indicator (as shown in Table 13)
- $b_8$  = slot 2 reception indicator (as shown in Table 13)
- $b_9$  = slot 3 reception indicator (as shown in Table 13)
- $b_{10}$  = slot 4 reception indicator (as shown in Table 13)
- $b_{11}$  = slot 5 reception indicator (as shown in Table 13)
- $b_{12}$  = slot 6 reception indicator (as shown in Table 13)
- $b_{13}$  = slot 7 reception indicator (as shown in Table 13)
- $b_{14}$  = slot 8 reception indicator (as shown in Table 13)
- $b_{15}$  = slot 9 reception indicator (as shown in Table 13)
- $b_{16}$ - $b_{17}$  = reservation control for next 3 ms period  
(6 ms for 256 kbit/s )
- $b_{18}$ - $b_{23}$  = CRC 6 parity (see definition in SL-ESF section)

When the upstream transmission grade is A/AQ, then only the first three slot reception indicators are valid. When the upstream transmission grade is B/BQ, then the 9 slots are valid. When the upstream transmission grade is C/CQ, the 9 slots of this field and the 9 slots of the following field are valid: two consecutive Slot Configuration fields are then used. The definition of the first Slot Configuration field is unchanged. The definition of the second Slot Configuration field extends the boundary definition to cover upstream slots 10 through 18, and the reception indicators to cover upstream slots 10 through 18. When the upstream transmission grade is D/DQ, four consecutive Slot Configuration fields are then used. The definition of the first Slot Configuration field is unchanged. The definition of the second Slot Configuration field extends the boundary definition to cover upstream slots 10 through 18, and the reception indicators to cover upstream slots 10 through 18. The definition of the third Slot Configuration field extends the boundary definition to cover upstream slots 19 through 27, and the reception indicators to cover upstream slots 19 through 27. The definition of the fourth Slot Configuration field extends the boundary definition to cover upstream slots 28 through 36, and the reception indicators to cover upstream slots 28 through 36.

In general, when the upstream rate is lower than the downstream rate, there are several OOB downstream superframes during groups of  $k$  upstream slots (where  $k = 3$  for grade A/AQ upstream,  $k = 9$  for grade B/BQ upstream). In that case, slot configuration information remain equal over all superframes corresponding to one group of  $k$  upstream slots.

**Ranging Slot Indicator (b0):** When this bit is active ( $b_0 = 1$ ), the first three slots of upstream channel "x" which correspond to the occurrence of the next superframe of the related downstream channel are designated as ranging slots. A ranging message may be transmitted in the second ranging slot according to the algorithm defined for ranging, and the first and third ranging slots may not be used for transmission (guard band for ranging operations).

**Slot Boundary Definition field (b1-b6):** Slot types are assigned to upstream slots using bits  $b_0 - b_6$ . The slots are grouped into "spans". In the case of upstream grades A and AQ, a span is the 3 slots between two 6(ms) time markers. Otherwise a span is 9 slots. In the case of upstream grades B and BQ there is 1 span between two 3(ms) time markers. In the case of upstream grades C and CQ there are 2 spans between two 3(ms) time markers. In the case of the upstream grades D and DQ there are 4 spans between two 3(ms) time markers. Within each span, the bits  $b_0 - b_6$  define regions, such that slots of the same type are contained within the same region. The order of the regions is Ranging slots, Contention based slots, Reserved slots and Fixed rate based slots. If a ranging slot is available within a "span", it will consist of the first three slot times in the "span", assuming  $b_1-b_6$  are not in the range 55-63 (see Table 12). A ranging slot is indicated by  $b_0 = 1$ . The boundaries between the remaining regions of the "spans" are defined by  $b_1-b_6$ . The boundaries are defined as shown in Table 10.

**Table 10: Slot Boundary Definition field (b1-b6)**

Boundary 0	slot 1
Boundary 1	slot 2
Boundary 2	slot 3
Boundary 3	slot 4
Boundary 4	slot 5
Boundary 5	slot 6
Boundary 6	slot 7
Boundary 7	slot 8
Boundary 8	slot 9
Boundary 9	

The boundary positions are defined by  $b_1-b_6$  as shown in Table 11.

**Table 11: Boundary positions (b1-b6)**

(note 1) (note 2)	0	1	2	3	4	5	6	7	8	9
0 (note 3)	0	1	2	3	4	5	6	7	8	9
1 (note 3)		10	11	12	13	14	15	16	17	18
2 (note 3)			19	20	21	22	23	24	25	26
3				27	28	29	30	31	32	33
4					34	35	36	37	38	39
5						40	41	42	43	44
6							45	46	47	48
7								49	50	51
8									52	53
9										54

NOTE 1: Row = Contention based/Reserved region boundary.  
 NOTE 2: Column = Reserved slot /Fixed rate based region boundary.  
 NOTE 3: When the ranging control slot indicator ( $b_0$ ) is set to "1", the values in rows 0 - 2 are illegal values, and values in row 3 means that there are no contention slots, because slots 1-3 are defined as ranging control slots.

EXAMPLE  $b_0 = 0, b_1-b_6 = 22$ : Contention (1-2), reserved (3-5), Fixed rate (6-9)

The remaining values of the Slot Boundary Definition Field are provided in Table 12.

**Table 12: Slot Boundary Definition Field**

<b>b1-b6 value</b>	<b>ranging control slots</b>	<b>contention slots</b>	<b>reservation slots</b>	<b>fixed rate slots</b>
55	1-6	7-9	-	-
56	1-6	7-8	-	9
57	1-6	7	8-9	-
58	1-6	7	8	9
59	1-6	7	-	8-9
60	1-6	-	7-8	9
61	1-6	-	7	8-9
62	1-6	-	-	7-9
63	1-9	-	-	-

NOTE 1: For  $b1-b6 = 55 - 63$ ,  $b0$  shall be set to 1. Note that for  $b1-b6$  between 55 and 62, two ranging slots are provided (2 and 5). For  $b1-b6 = 63$ , three ranging slots are provided (2, 5, and 8).

The values in the above Tables are derived from  $b1-b6$  in the following manner:

$$b1 + (b2 \times 2) + (b3 \times 4) + (b4 \times 8) + (b5 \times 16) + (b6 \times 32)$$

**Warning:** this formula indicates that  $b6$  is considered as msb of  $b1-b6$  word, whereas  $b0$  is msb of the entire word  $b0-b23$ . Although this "looks" inconsistent, it has not been changed for the purpose of compatibility with the DAVIC standard.

When the upstream data channel is a 256 kbit/s data channel, then only the first four rows and columns of Table 11 are valid, and Table 12 is not valid.

NOTE 2: If slot boundary fields change while some NIUs have already been allocated slots in the reservation slots area, these NIUs are responsible of updating the list of physical slots. Specifically, slots are assigned by MAC Reservation Grant messages, which contain a Reference slot that does not depend on the slot boundary fields and a Grant\_slot\_count which corresponds to the number of slots assigned within the reservation slots boundary field. If the field changes, the list of physical slots on which the NIU can transmit automatically changes accordingly.

**Slot Reception Indicators (b7 - b15):** When a slot reception indicator is active ("1"), this indicates that an upstream packet was received without collision. The relationship between a given US slot and its indicator is shown in Table 13. When the indicator is inactive ("0"), this indicates that either a collision was detected or no upstream packet was received in the corresponding upstream slot.

Slot reception indicators lead to the retransmission procedure only when contention access is used as described in clause 5.5.2.4.

Table 13: Relationship of US slot to DS Reception Indicator

	1,544 Mbit/s Downstream	3,088 Mbit/s Downstream
<b>Grade A/AQ Upstream</b>		
<b>Grade B/BQ Upstream</b>		
<b>Grade C/CQ Upstream</b>		
<b>Grade D/DQ Upstream</b>		
<p>NOTE 1: 'I' indicates the downstream frame(s) in which Reception Indicators (contained within the Flag Sets or Rxbits) are sent. These indicators control the upstream slots in the shaded area.</p> <p>NOTE 2: In the 3,088 Mbit/s downstream, two successive frames contain Flag Sets 1...16.</p> <p>NOTE 3: Two successive Flag Sets are used to control the 18 slots of a grade C/CQ upstream channel. In this case you can control max. 4 upstreams using the 1,544 Mbit/s downstream.</p> <p>NOTE 4: Four successive Flag Sets are used to control the 36 slots of a grade D/DQ upstream channel. In this case you can control max. 2 upstreams using the 1,544 Mbit/s downstream and max. 4 upstreams using the 3,088 Mbit/s downstream.</p> <p>NOTE 5: On this drawing, the DS 3 ms period #n is aligned with the US 3 ms #n only for ease of understanding. It is not at all supposed to be a time alignment. For timing relationship between US and DS refer to clause 5.4, Slot timing assignment.</p>		

**Reservation Control (b16-b17):** When the reservation control field has the value of 0, no reservation attempts are allowed to be transmitted on the corresponding QPSK upstream channel during the slot positions associated with the next 3 ms period. When the reservation control field has the value of 1, reservation attempts can be made. The values 2 and 3 are reserved. A reservation attempt corresponds to sending a MAC Reservation Request message or a piggyback request (see MAC section), b16 is msb.

**CRC 6 Parity (b18-b23):** This field contain a CRC 6 parity value calculated over the previous 18 bits. The CRC 6 parity value is described in the SL-ESF frame format clause 5.3.1.2, b18 is msb.

In the case where there is more than one OOB DS QPSK channel related to an upstream QPSK channel, the SL-ESF overhead bits and the payload R-bytes shall be identical in those OOB DS channels, with the exception of the overhead CRC (C1-C6) bits, which are specific to each of those OOB DS channels. Such related DS channels shall be synchronized (transmitted synchronously). This scenario applies for example when a lot more bandwidth is needed for DS information than US information. An NIU is but not required to have more than one QPSK tuner.

The MAC messages that are required to perform the MAC functions for the upstream channel shall be transmitted on each of its related OOB DS channels.

### Trailer bytes

These bytes are not used. They are equal to 0.

## 5.3.2 Forward Interaction Path (Downstream IB)

### 5.3.2.1 IB Signalling MPEG2-TS Format (MAC Control Message)

The structure that is utilized when the downstream QAM channel is carrying MPEG2-TS packets is shown in Figure 23. MSBs of each field are transmitted first.

4	3	2	3	26	26	40	40	40	4
MPEG Header	Upstream Marker	Slot Number	MAC Flg Control	MAC Flags	Ext. Flags	MAC msg.	MAC msg.	MAC msg.	rsrv

**Figure 23: Frame structure (MPEG-2 TS format)**

where:

**MPEG Header** is the 4 byte MPEG-2 Transport Stream Header as defined in ISO/IEC 13818-1 [20] with a specific PID designated for MAC messages. This PID is 0x1C. The transport\_scrambling\_control field of the MPEG header shall be set to '00'.

NOTE: The transport\_priority bit is ignored by the NIU. The payload\_unit\_start\_indicator bit is ignored by the NIU for MPEG TS packets containing MAC messages. The adaptation\_field\_control bits must be set to '01' for MPEG TS packets containing MAC messages.

**Upstream Marker** is a 24-bit field which provides upstream QPSK synchronization information. (As mentioned in clause 5.1.4, at least one MPEG TS packet with synchronization information shall be sent in every period of 3 ms). The definition of the field is as follows:

- **bit 0: upstream marker enable (msb)**

When this field has the value '1', the slot marker pointer is valid. When this field has the value '0', the slot marker pointer is not valid.

- **bit 1 - 3: MAC Message Framing**

Bit 1 relates to the first MAC message slot within the MPEG frame, bit 2 to the second, and bit 3 to the last slot. The meaning of each bit is:

- 0: a MAC message terminates in this slot.
- 1: a MAC message continues from this slot into the next, or the slot is unused, in which case the first two bytes of the slot are 0x0000.

After an unused slot, no more MAC messages can appear in that MPEG TS packet. One MAC message cannot be split to different MPEG TS packets. So the only valid interpretation of bit 1 – 3 is:

Bit 1 - 3	Slot 1	Slot 2	Slot 3
000	M040	M040	M040
001	M040	M040	Unused
010	M040	M080	
011	M040	Unused	Unused
100	M080		M040
101	M080		Unused
110	M120		
111	Unused	Unused	Unused

Where Mxxx means that a MAC message with not more than xxx bytes length is carried in that slot(s).

- **bit 4 - 7: reserved**

- **bit 8 - 23: upstream slot marker pointer**

The slot marker pointer is a 16 bit unsigned integer which indicates the number of downstream "symbol" clocks between the next Sync byte and the next 3 ms time marker. Bit 23 is to be considered as the most significant bit of this field.

**Slot Number** is a 16-bit field which is defined as follows: (as mentioned in clause 5.1.4, at least one MPEG TS packet with synchronization information shall be sent in every period of 3 ms).

- **bit 0: slot position register enable (msb)**

When this field has the value '1', the slot position register is valid. When this field has the value '0', the slot position register is not valid.

- **bit 1-3: reserved**

- **bit 4 is set to the value '1'. This bit is equivalent to M12 in the case of OOB downstream.**

- **bit 5: odd parity**

This bit provides odd parity for upstream slot position register. This bit is equivalent to M11 in the case of OOB downstream.

- **bits 6-15: upstream slot position register**

The upstream slot position register is a 10-bit counter which counts from 0 to n with bit 6 the msb. These bits are equivalent to M10-M1 in the case of OOB downstream.

(See clause 5.4 for more information on the functionality of the upstream slot position register).

**MAC Flag Control** is a 24-bit field (b0 (msb), b1, b2...b23) which provides control information which is used in conjunction with the 'MAC Flags' and 'Extension Flags' fields. The definition of the MAC Flag Control field is as follows:

- b0-b2 Channel 0 control field
- b3-b5 Channel 1 control field
- b6-b8 Channel 2 control field
- b9-b11 Channel 3 control field
- b12-b14 Channel 4 control field
- b15-b17 Channel 5 control field
- b18-b20 Channel 6 control field
- b21-b23 Channel 7 control field

Each of the above Channel "c" Control Fields is defined as follows:

- Channel "c" control field (a, b, c) = (bn, bn+1, bn+2) where  $n = 3 \times c$
- bit a: 0 - MAC Flag Set of channel "c" disabled.

1 - MAC Flag Set of channel "c" enabled:

'MAC Flag Set of Channel "c" enabled' means that the Mac Flags assigned to the upstream channel 'c' are valid in this MPEG TS packet. The relation between the channel number 'c' and the assigned Mac Flag sets is provided in the 'Default Configuration', 'Connect', 'Reprovision' and 'Transmission control' messages.

In case of a 3,088 Mbit/s upstream channel, two sets of Flags are required. In this case, the MAC\_Flag\_Set parameter represents the first of two successively assigned Flag sets. The definition of the second slot configuration field extends the boundary definition to slots 10 through 18, and the reception indicators cover slots 10 through 18.

In case of a 6,176 Mbit/s upstream channel, four sets of Flags are required. In this case, the MAC\_Flag\_Set parameter represents the first of four successively assigned Flag sets. The definition of the second slot configuration field extends the boundary definition to slots 10 through 18, and the reception indicators cover slots 10 through 18. The definition of the third Slot Configuration field extends the boundary definition to cover upstream slots 19 through 27, and the reception indicators to cover upstream slots 19 through 27. The definition of the fourth Slot Configuration field extends the boundary definition to cover upstream slots 28 through 36, and the reception indicators to cover upstream slots 28 through 36.

- bit b,c: 00 - all flags valid for second previous 3 ms (6 ms for 256 kbit/s Upstream) period (out-of-band signalling equivalent):
- 01 - flags valid for 1st ms (2 ms for 256 kbit/s Upstream) of previous 3 ms (6 ms for 256 kbit/s Upstream) period;
  - 10 - flags valid for 2nd ms (2 ms for 256 kbit/s Upstream) of previous 3 ms (6 ms for 256 kbit/s Upstream) period;
  - 11 - flags valid for 3rd ms (2 ms for 256 kbit/s Upstream) of previous 3 ms (6 ms for 256 kbit/s Upstream) period.

**MAC Flags** is a 26 byte field containing 8 slot configuration fields (24 bits each) which contain slot configuration information for the related upstream channels followed by two reserved bytes ( The First 3 bytes correspond to MAC Flag Set 1, second 3 bytes to MAC Flag Set 2, etc). The definition of each slot configuration field is defined as follows:

- b0 ranging control slot indicator for next 3 ms (6 ms for 256 kbit/s Upstream) period (msb)
- b1-b6 slot boundary definition field for next 3 ms (6 ms for 256 kbit/s Upstream) period
- b7 slot 1 reception indicator for [second] previous 3 ms (6 ms for 256 kbit/s Upstream) period
- b8 slot 2 reception indicator for [second] previous 3 ms (6 ms for 256 kbit/s Upstream) period
- b9 slot 3 reception indicator for [second] previous 3 ms (6 ms for 256 kbit/s Upstream) period
- b10 slot 4 reception indicator for [second] previous 3 ms (6 ms for 256 kbit/s Upstream) period
- b11 slot 5 reception indicator for [second] previous 3 ms (6 ms for 256 kbit/s Upstream) period
- b12 slot 6 reception indicator for [second] previous 3 ms (6 ms for 256 kbit/s Upstream) period
- b13 slot 7 reception indicator for [second] previous 3 ms (6 ms for 256 kbit/s Upstream) period
- b14 slot 8 reception indicator for [second] previous 3 ms (6 ms for 256 kbit/s Upstream) period
- b15 slot 9 reception indicator for [second] previous 3 ms (6 ms for 256 kbit/s Upstream) period
- b16-17 reservation control for next 3 ms (6 ms for 256 kbit/s Upstream) period
- b18-b23 CRC 6 parity

For a detailed description of the fields "ranging control slot indicator", "slot boundary definition", "reservation control" and "CRC 6 parity", please refer to clause 5.3.1.3.

The slot configuration fields are used in conjunction with the MAC Flag Control field defined above. Note that when the MAC Flag Control field designates that a 1 ms (2 ms for 256 kbit/s Upstream) flag update is enabled; (1) the reception indicators refer to the previous 3 ms (6 ms for 256 kbit/s Upstream) period (the bracketed term [second] is omitted from the definition), (2) only the reception indicators which relate to slots which occur during the designated 1 ms (2 ms for 256 kbit/s Upstream) period are valid, and (3) the ranging control slot indicator, slot boundary definition field, and reservation control field are valid and consistent during each 3 ms (6 ms for 256 kbit/s Upstream) period.

**Extension Flags** is a 26 byte field which is used when the MAC\_Flag\_Set parameter associated to one of the upstream channels (this link is done in the MAC Default Configuration Message, Connect Message, Reprovision Message and Transmission Control Message) is greater than 8 for a 256 kbit/s or 1,544 Mbit/s upstream channel, greater than 7 for a 3,088 Mbit/s upstream channel or greater than 5 for a 6,176 Mbit/s upstream channel. The definition of the Extension Flags field is identical to the definition of the MAC Flags field above. The "Extension Flags" field contains the MAC Flags from 9 to 16.



The **MAC Message** field contains a 40 byte message, the general format is defined in clause 5.5.2.7.

**reserved field c** is a 4 byte field reserved for future use.

### 5.3.2.2 Frequency of IB Signalling Information

#### IB Downstream and Upstream Time-Tick Definition

In the case of IB, downstream time-tick  $T_{dn}$  is the 3 ms time marker Downstream (defined in clause 5.4.2) (to derive the 6 ms period in the case of an upstream transmission bit rate of 256kbit/s, see clause 5.4.4).

IB Upstream Time-Tick, Absolute\_Time\_Offset and New\_Absolut\_Time\_Offset definitions are the same as for OOB (see clause 5.3.1.3).

#### Upstream Marker and Slot Position Register Number

The MAC Control Message structures shall be transmitted one time every 3 ms with an enabled slot position register (slot\_position\_register\_enable = 1) and a valid upstream marker (upstream\_Marker\_enable = 1) (i.e. both are valid in the same MPEG TS packet).

#### MAC Flag Control, MAC Flags & Extension Flags

The MAC Control Message structures containing MAC Flag Control, MAC Flags & Extension Flags shall be transmitted so as to the NIU has at least 1 ms to process the MAC Flag Information. This information shall be received by the NIU between two downstream time-ticks (see clause 5.3.1.3).

#### MAC Messages

Additional MAC Control Message structures containing only MAC messages, i.e. with a disabled slot position register (slot\_position\_register\_enable = 0), a disabled upstream marker (upstream\_marker\_enable = 0) may be transmitted at any time.

### 5.3.3 Return Interaction Path (Upstream)

#### 5.3.3.1 Slot Format

The format of the upstream slot depends on the modulation used.

The format for QPSK modulation is shown in Figure 24. A Unique Word (UW) (4 bytes) provides a burst mode acquisition method. The payload area (53 bytes) contains a single ATM cell. The RS Parity field (6 bytes) provides  $t = 3$  Reed Solomon protection RS(59,53) over the payload area. The Guard band (1 byte) provides spacing between adjacent upstream packets.

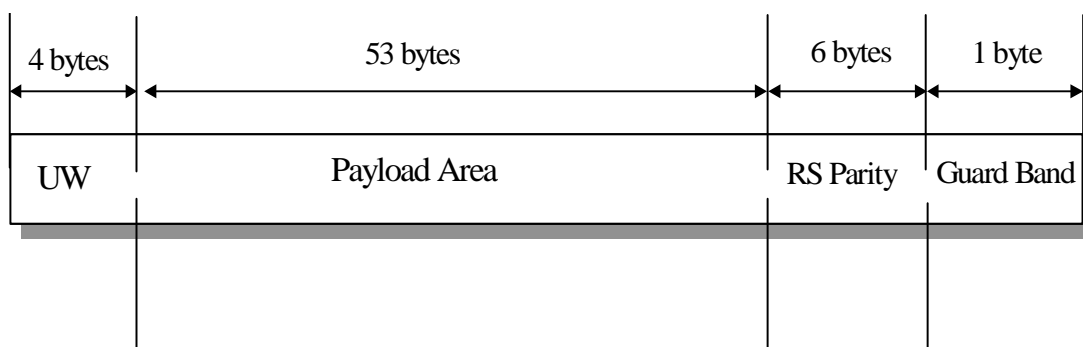
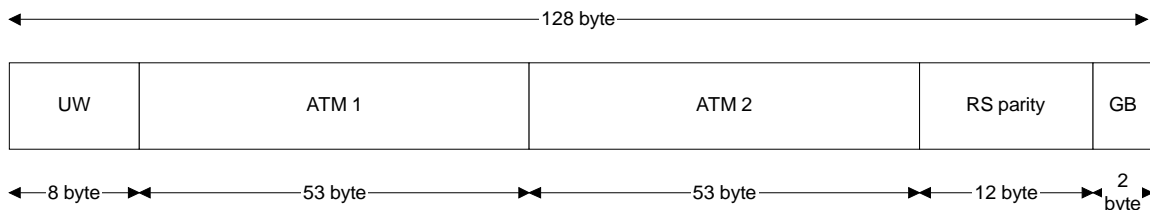

Figure 24: Slot format for QPSK

The format of an upstream packet for 16QAM modulation is shown in Figure 25. A Unique Word (UW) (8bytes) provides a burst mode acquisition method. The payload area (106 bytes) contains two ATM cells. The RS Parity field (12 bytes) provides  $t = 6$  Reed Solomon protection. In case the NIU sends 1 ATM cell in the slot, the data is sent in the first ATM cell, and the second ATM cell is sent as null ATM cell.



**Figure 25: Slot format for 16QAM**The structure and field coding of the ATM cells shall be consistent with the structure and coding given in ITU-T Recommendation I.361 [1] for ATM UNI

### Unique Word

For QPSK modulation, the unique word is four bytes long: CC CC CC 0D hex. The unique word for minislots is four bytes: CC CC CC 0E hex, transmitted in this order.

For 16QAM modulation, the unique word is eight bytes long: F3 F3 F3 F3 F3 F3 33 F7 hex. The unique word for minislots is also 8 bytes long: F3 F3 F3 F3 F3 F3 33 FB.

### ATM Cell Structure

The format for each ATM cell structure is illustrated below. This structure and field coding shall be consistent with the structure and coding given in ITU-T Recommendation I.361 [1] for ATM UNI.

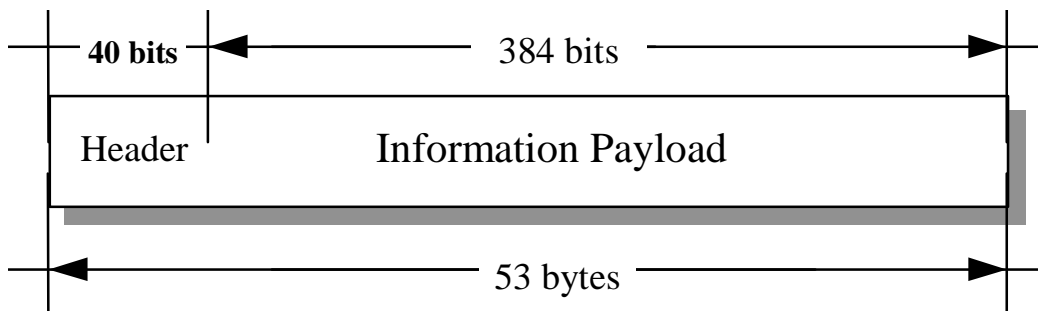

**Figure 26: ATM cell format**

The entire header (including the HEC byte) shall be protected by the Header Error Control (HEC) sequence. The HEC code shall be contained in the last byte of the ATM header. The HEC sequence shall be capable of:

- single-bit error correction;
- multiple-bit error detection.

Error detection in the ATM header shall be implemented as defined in [16]. The HEC byte shall be generated as described in [16], including the recommended modulo-2 addition (XOR) of the pattern 01010101b to the HEC bits. The generator polynomial coefficient set used and the HEC sequence generation procedure shall be in accordance with [16].

### Channel Coding

Reed-Solomon encoding shall be performed on the data contained in a single upstream packet (1 ATM cell for QPSK and the combined 2 ATM cells for 16QAM).

For QPSK  $T = 3$ , this means that 3 erroneous byte per ATM cell can be corrected. This process adds 6 parity bytes to the ATM cell to give a codeword of (59,53). The shortened Reed-Solomon Code shall be implemented by appending 196 bytes, all set to zero, before the information bytes at the input of a (255,249) encoder; after the coding procedure these bytes are discarded.

In the case of 16QAM modulation, the RS field should be calculated on the combined data stream of 2 ATM cells with  $T = 6$ . This will mean that 6 erroneous bytes for 2 ATM cells can be corrected. 12 parity bytes will be added, to give a codeword of (118,106).

The Reed-Solomon code shall have the following generator polynomials:

Code Generator Polynomial:

$$g(x) = (x + \mu^0)(x + \mu^1)(x + \mu^2) \dots (x + \mu^5),$$

where  $\mu = 02$  hex

Field Generator Polynomial:

$$p(x) = x^8 + x^4 + x^3 + x^2 + 1$$

### **Guard Band**

For QPSK the guard band is 1 byte long (4 QPSK symbols). It provides some extra protection against synchronization errors.

For 16QAM the guard band is 2 bytes long (4 16QAM symbols). It provides some extra protection against synchronization errors.

For the minislot format see clause 5.7.2.

### **5.3.4 Minimum Processing Time**

The NIU has to be able to process the boundary information in the Mac flag sets within 1 ms.

## 5.4 Slot Timing Assignment

### 5.4.1 Downstream Slot Position Reference (Downstream OOB)

Upstream synchronization is derived from the downstream extended superframe (OOB) by noting the slot positions as shown in Table 14.

**Table 14: Downstream slot position reference**

Frame Number	Bit Number	Overhead Bit	Slot position reference
1	0	<b>M1</b>	◆ Slot Position (see note)
2	193	C1	
3	386	M2	
4	579	F1 = 0	
5	772	M3	
6	965	C2	
7	1158	M4	
8	1351	F2 = 0	
9	1544	<b>M5</b>	◆ Slot Position
10	1737	C3	
11	1930	M6	
12	2123	F3 = 1	
13	2316	M7	
14	2509	C4	
15	2702	M8	
16	2895	F4 = 0	
17	3088	<b>M9</b>	◆ Slot Position
18	3281	C5	
19	3474	M10	
20	3667	F5 = 1	
21	3860	M11	
22	4053	C6	
23	4246	M12	
24	4439	F6 = 1	

**NOTE:** The first slot position is also called the 3 ms time marker in the case of 1,544 Mbit/s rate downstream. For the 3,088 Mbit/s rate downstream, the 3 ms time marker only appears once every two superframes. The M12 bit (see clause 5.4) is used to differentiate between the two superframes.

### 5.4.2 Downstream Slot Position Reference (Downstream IB)

Upstream synchronization is derived from the Transport Stream by noting the 3 ms time marker Downstream as shown in Figure 27. From the bits of the upstream marker field contained in the MPEG-2 TS packet, the 3 ms time marker is obtained by counting a number of symbol clocks equal to (b23-b8). This marker is equivalent to the first slot position of the superframe for the OOB case.

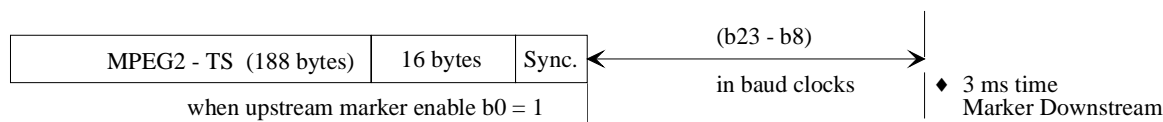

**Figure 27: Position of the 3 ms time marker for IB signalling**

In order to describe how the US slot position is derived from the location of the DS 3 ms time marker at the NIU, consider the following system diagram.

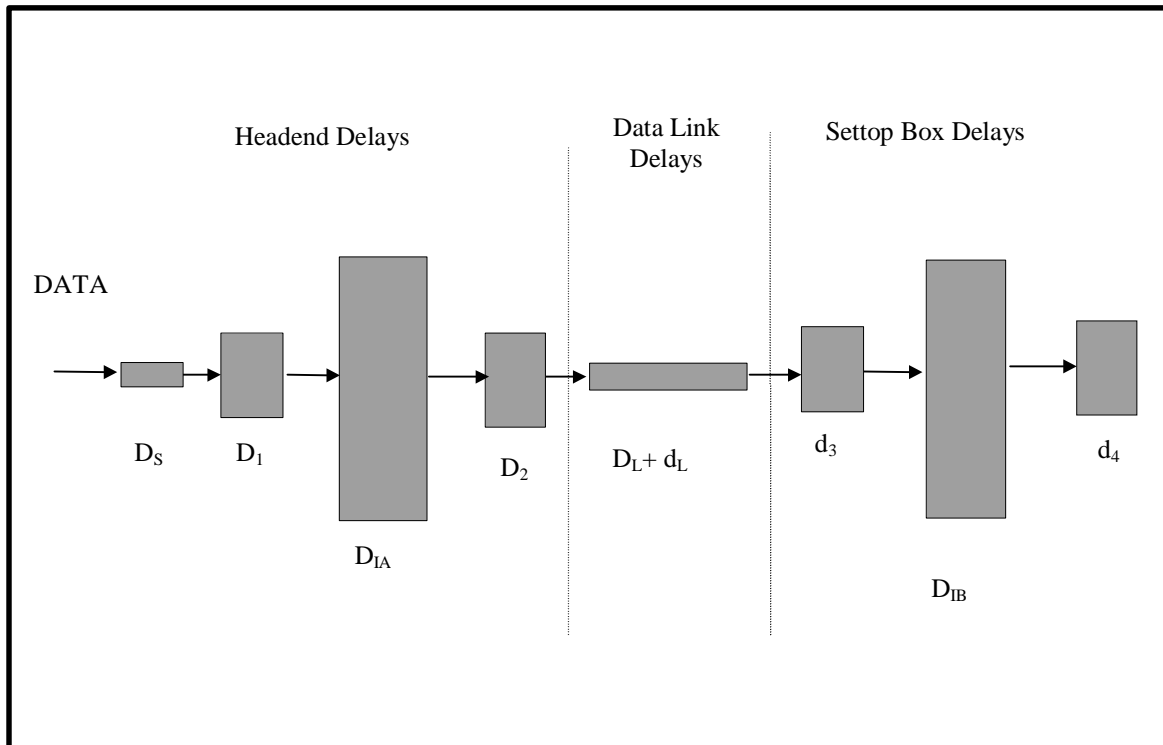

**Figure 28: System model for timing analysis**

The delay between the location of the end of the Upstream Marker and the beginning of the next Sync byte, designated as  $D_s$ , is a constant value for each bit rate equal to the equivalent time of 197 bytes, or

$$(197 \times 8 / x) \text{ symbol clocks}$$

where:

$x = 4$ , for 16 QAM

5, for 32-QAM

6, for 64 QAM

7, for 128-QAM

8, for 256 QAM

There will be some processing delay in the Headend hardware between the location where the Upstream Marker is inserted in the MAC packet and the arrival of the data into the interleaver. This should be a constant delay,  $D_1$ , which is the same for every incoming byte, including the sync byte following the Upstream Marker.

The delay due to the interleaving process in the Headend is  $D_{IA}$  and will be zero for each sync byte.

There will be some processing delay in the Headend hardware between the output of the interleaver and the output of the QAM modulator. This should be a constant delay,  $D_2$ , for every byte in the outgoing stream.

The data link is composed of two delay values,  $D_L$ , the constant link delay that every STU experiences, and  $d_L$ , the variable link delay for each STU which is due to the fact that each STU is located at a different distance from the Headend. This variable link delay is compensated for by the ranging operation.

There will be some processing delay in the STU hardware between the input of the QAM demodulator and the input of the de-interleaver. This delay is design dependent,  $d_3$ , and may be a constant delay or a variable delay for each byte in the data stream.

The delay due to the de-interleaving process in the STU is  $D_{IB}$ , and will be equal to the entire interleave delay for each sync byte.

The total interleave delay,

$$D_I = D_{IA} + D_{IB}$$

will be constant for each byte. The value will be given by

$$D_I = 204 \times 8 \times (\text{interleave\_depth}-1)/\text{bit rate}$$

for example, if the modulation is QAM 64 with a baud rate of 5,0 Mbit/s,

$$D_I = 204 \times 8 \times 11/30M = 598,4 \mu\text{s} \text{ or } 2,992 \text{ symbol clocks}$$

There will be some processing delay in the STU hardware between the output of the de-interleaver and the circuitry that utilizes the Upstream marker and following sync byte for generating the local 3 ms time marker. This delay, which includes Reed Solomon FEC, is design dependent,  $d_4$ , and may be a constant delay or a variable delay for each byte in the data stream.

The accumulated delay in the data link is composed of a number of constant terms and three variable terms. The constant terms will be identical for every STU that is utilizing a particular QAM channel for in-band timing and thus becomes a fixed offset between when the counter which is loading the Upstream Marker value and the actual location of the 3 ms time marker at each STU. Each STU is responsible for compensating for the design dependent delays,  $d_3$  and  $d_4$ , before utilizing the Upstream Marker value for generating the 3 ms time marker. The variable link delay,

$d_L$ , will be compensated for via the ranging algorithm, in the same way as performed when out-of-band signalling is employed.

### 5.4.3 Upstream Slot Positions

Transmission on each QPSK/16QAM upstream channel is based on dividing access by multiple NIU units by utilizing a negotiated bandwidth allocation slot access method. A slotting methodology allows the transmit slot locations to be synchronized to a common slot position reference, which is provided via the related downstream MAC control channel. Synchronizing the slot locations increases message throughput of the upstream channels since the upstream packets do not overlap during transmission.

The slot position reference for upstream slot locations is received via the related downstream MAC control channel by each NIU. Since each NIU receives the downstream slot position reference at a slightly different time, due to propagation delay in the transmission network, slot position ranging is required to align the actual slot locations for each related upstream channel. The upstream slot rates are 12 000 upstream slots/s when the upstream transmission grade is D/DQ, 6 000 upstream slots/s when the upstream transmission grade is C/CQ, 3 000 upstream slots/s when the upstream transmission grade is B/BQ and 500 upstream slots/s when the upstream transmission grade is A/AQ.

The number of slots available in any one second is given by:

$$\text{number of slots/s} = (\text{upstream transmission bit rate})/(\text{number of bits per upstream packet}) - (\text{extra guardband})$$

where extra guardband may be designated between groups of slots for alignment purposes. The number of bits per upstream packet is 512 for QPSK and 1024 for 16QAM.

The M-bits in the SL-ESF serve two purposes:

- to mark the slot positions for the upstream Contention and Reservation and Fixed Rate based signalling links (see clause 5.4);
- to provide slot count information for upstream message bandwidth allocation management in the NIU.

M-bits M1, M5, and M9 mark the start of an upstream slot position for upstream message transmission.

### 5.4.3.1 Rate 256 kbit/s QPSK, 512 kbit/s 16QAM

In the case where the upstream transmission grade is A/AQ and the downstream OOB rate is 1,544 Mbit/s, the upstream slots are numbered as follows:

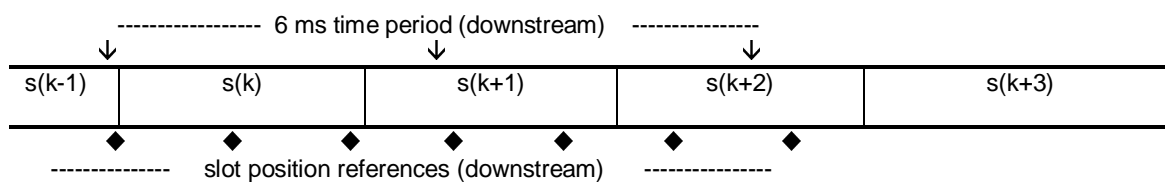

where k is a multiple of 3. In the case where the downstream OOB rate is 3,088 Mbit/s, there are 12 slot position references downstream during the transmission of 3 upstream packets. In the case of IB downstream, packet «k» is sent when the 3 ms time marker is received.

The relationship between the received slot position reference and the actual slot transmit position is given by:

$$\text{slot\_transmit\_position} = \text{slot\_position\_reference (valid)} + \text{slot\_position\_offset}$$

where only the slot\_position\_references which cause the upstream\_slot\_position\_counter to be loaded with an integer value are valid (see clause 5.4.4), and the slot\_position\_offset is derived from the Time\_Offset\_Value provided via the Range\_and\_Power\_Calibration\_Message in the MAC protocol.

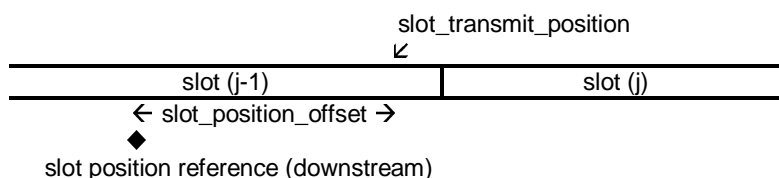

In the case where the upstream transmission grade is A/AQ, the actual slot transmission locations correspond directly to the slot transmit positions.

### 5.4.3.2 Rate 1,544 Mbit/s QPSK, 3,088 Mbit/s 16QAM

In the case where the upstream transmission grade is B/BQ and the downstream OOB rate is 1,544 Mbit/s, the upstream slots are numbered as follows:

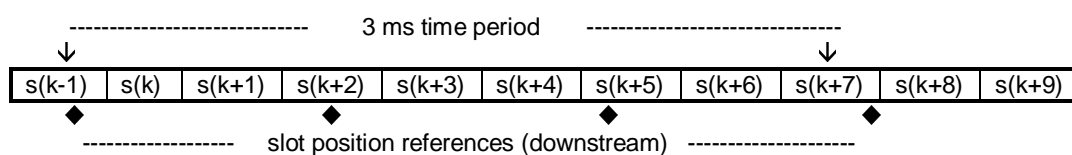

where k is a multiple of 9. In the case where the downstream OOB rate is 3,088 Mbit/s, there are 6 slot position references downstream during the transmission of 9 upstream packets. In the case of IB downstream, packet «k» is sent when the 3 ms time marker is received.

The relationship between the received slot position reference and the actual slot transmit position is given by:

$$\text{slot\_transmit\_position} = \text{slot\_position\_reference(valid)} + \text{slot\_position\_offset}$$

where only the slot\_position\_references which cause the upstream\_slot\_position\_counter to be loaded are valid (see clause 5.4.4), and the slot\_position\_offset is derived from the Time\_Offset\_Value provided via the Range\_and\_Power\_Calibration\_Message in the MAC protocol.

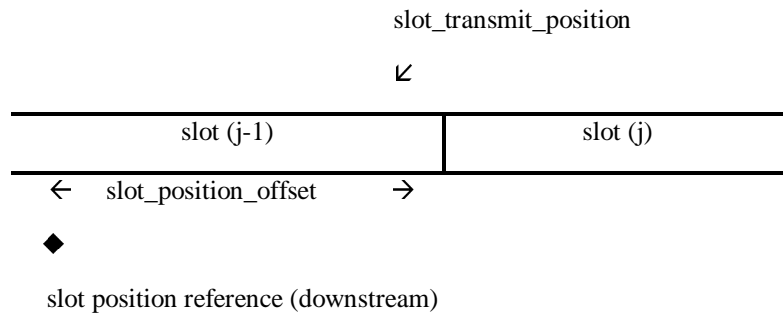

In the case where the upstream transmission grade is B/BQ, the actual slot transmission locations are given by

$$\text{slot\_transmission\_location (m)} = \text{slot\_transmit\_position} + (m \times \text{number of bits per upstream packet});$$

where m = 0, 1, 2; is the position of the slot with respect to the slot\_transmit\_position. This leaves a free time interval (FI = 8bits) before the next slot\_transmit\_position occurs, during which no NIU transmits anything. The number of bits per upstream packet is 512 for QPSK and 1024 for 16QAM.

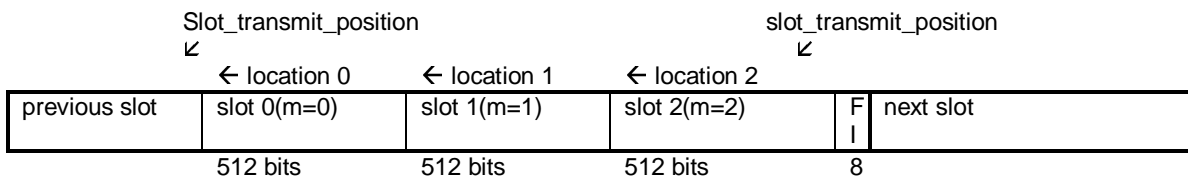

### 5.4.3.3 Rate 3,088 Mbit/s QPSK, 6,176 Mbit/s 16QAM

In the case where the upstream transmission grade is C/CQ and the downstream OOB rate is 1,544 Mbit/s, the upstream slots are numbered as shown below, where k is a multiple of 18.

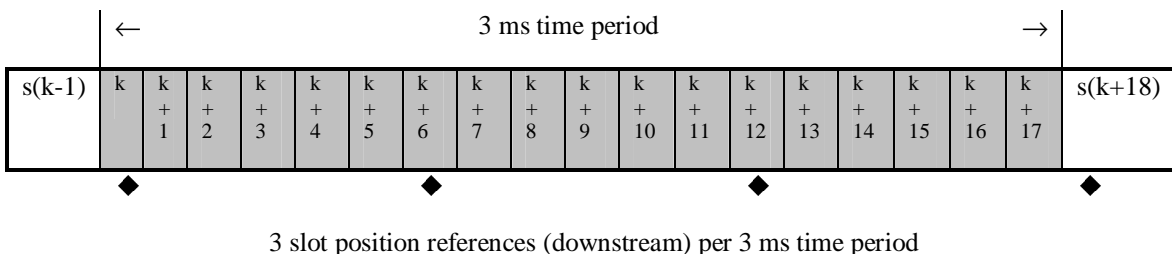

In the case where the downstream OOB rate is 3,088 Mbit/s, there are 6 slot position references downstream during the transmission of 18 upstream packets. In the case of IB downstream, packet «k» is sent when the 3 ms time marker is received.

The relationship between the received slot position reference and the actual slot transmit position is given by:

$$\text{slot\_transmit\_position} = \text{slot\_position\_reference(valid)} + \text{slot\_position\_offset}$$

where only the slot\_position\_references which cause the upstream\_slot\_position\_counter to be loaded are valid (see clause 5.4.4), and the slot\_position\_offset is derived from the Time\_Offset\_Value provided via the Range\_and\_Power\_Calibration\_Message.



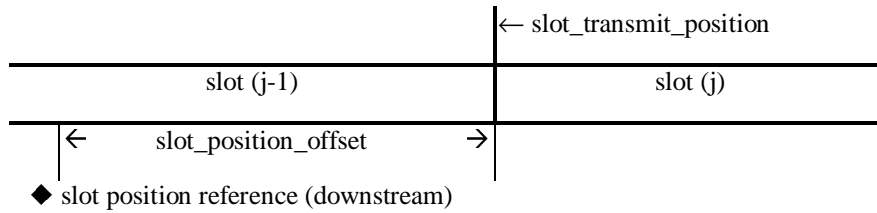

In the case where the upstream transmission grade is C/CQ, the actual slot transmission locations are given by:

$$\text{slot\_transmission\_location (m)} = \text{slot\_transmit\_position} + (m \times \text{number of bits per upstream packet});$$

where  $m = 0, 1, 2, 3, 4, 5$ ; is the position of the slot with respect to the slot\_transmit\_position. This leaves a free time interval (FI = 16 bits) before the next slot\_transmit\_position occurs, during which no NIU transmits anything. The number of bits per upstream packet is 512 for QPSK and 1024 for 16QAM.

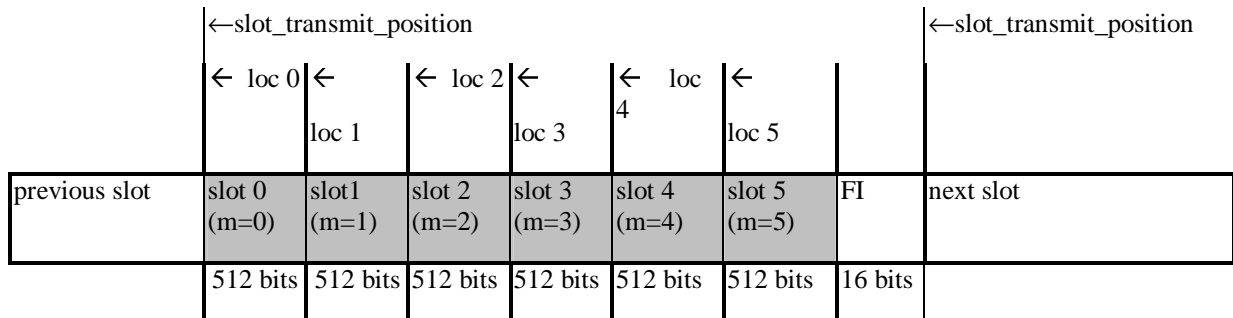

#### 5.4.3.4 Rate 6,176 Mbit/s QPSK, 12,352 Mbit/s 16QAM

In the case where the upstream transmission grade is D/DQ and the downstream OOB rate is 1,544 Mbit/s, the upstream slots are numbered as shown below, where  $k$  is a multiple of 36.

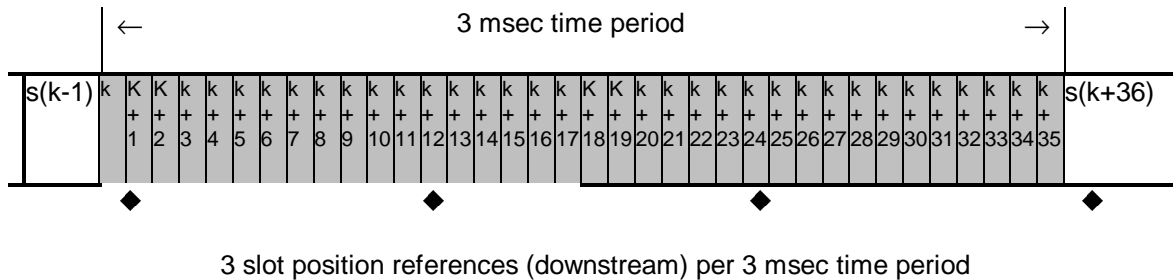

In the case where the downstream OOB rate is 3,088 Mbit/s, there are 6 slot position references downstream during the transmission of 36 upstream packets. In the case of IB downstream, packet "k" is sent when the 3 ms time marker is received.

The relationship between the received slot position reference and the actual slot transmit position is given by:

$$\text{slot\_transmit\_position} = \text{slot\_position\_reference(valid)} + \text{slot\_position\_offset}$$

where only the slot\_position\_references which cause the upstream\_slot\_position\_counter to be loaded are valid (see clause 5.4.4), and the slot\_position\_offset is derived from the Time\_Offset\_Value provided via the Range\_and\_Power\_Calibration\_Message.

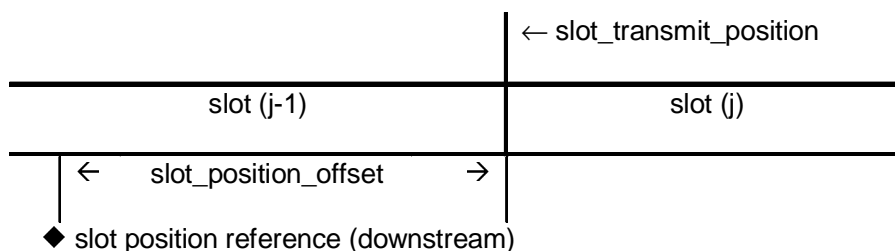

In the case where the upstream transmission grade is D/DQ, the actual slot transmission locations are given by:

$$\text{slot\_transmission\_location (m)} = \text{slot\_transmit\_position} + (m \times \text{number of bits per upstream packet});$$

where  $m = 0, 1, 2, 3, 4, 5, 6, 7, 8, 9, 10, 11$ ; is the position of the slot with respect to the `slot_transmit_position`. This leaves a free time interval ( $\text{FI} = 32$  bits) before the next `slot_transmit_position` occurs, during which no NIU transmits anything. The number of bits per upstream packet is 512 for QPSK and 1024 for 16QAM.

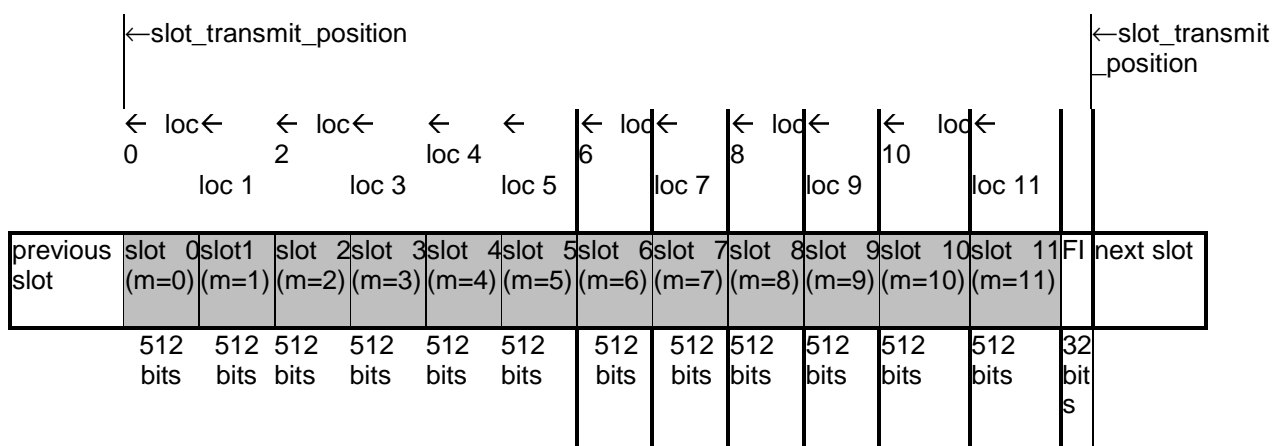

#### 5.4.4 Slot Position Counter

The M-bits M10 - M1 are a register, called the upstream slot position register, which counts from 0 to N, incrementing by one every 3 ms, where N is an unsigned integer which indicates slot position cycle size (the value of N is calculated from `Service_Channel_Last_Slot` sent in the Default Configuration Message and the upstream transmission bit rate of the service channel. For the case of a grade A/AQ service channel, the maximum value of `Service_Channel_Last_Slot` is 1535, for the cases of grade B/BQ and grade C/CQ the maximum value is imposed to be 8189, and for the case of grade D/DQ the maximum value is imposed to be 8171. The value of N shall be the same for all DS carriers, and N is related to the number of US slots by:

$$\text{Number\_of\_US\_Slots} = 3 \times m \times (N+1), \text{ where } m \text{ is related to US rate as described below.}$$

The upstream slot position register indicates the upstream slot positions that will correspond to the next SL-ESF frame.

For QPSK modulation, there are 12 upstream slots per ms when the upstream transmission bit rate is 6,176 Mbit/s, 6 upstream slots per ms when the upstream transmission bit rate is 3,088 Mbit/s, 3 upstream slots per ms when the upstream transmission bit rate is 1,544 Mbit/s, and there is 0,5 upstream slot per ms when the upstream transmission bit rate is 256 kbit/s. The corresponding upstream slot rates are, therefore, 12 000 upstream slots/s when the upstream transmission bit rate is 6,176 Mbit/s, 6 000 upstream slots/s when the upstream transmission bit rate is 3,088 Mbit/s, 3 000 upstream slots/s when the upstream transmission bit rate is 1,544 Mbit/s, and 500 upstream slots/s when the upstream transmission bit rate is 256 kbit/s.

For 16QAM modulation, there are 12 upstream slots per ms when the upstream transmission bit rate is 12,352 Mbit/s, 6 upstream slots per ms when the upstream transmission bit rate is 6,176 Mbit/s, 3 upstream slots per ms when the upstream transmission bit rate is 3,088 Mbit/s, and there is 0,5 upstream slot per ms when the upstream transmission bit rate is 512 kbit/s. The corresponding upstream slot rates are, therefore, 12000 upstream slots/s when the upstream transmission bit rate is 12,352 Mbit/s, 6 000 upstream slots/s when the upstream transmission bit rate is 6,176 Mbit/s, 3 000 upstream slots/s when the upstream transmission bit rate is 3,088 Mbit/s, and 500 upstream slots/s when the upstream transmission bit rate is 512 kbit/s.

For QPSK modulation, there are 36 upstream minislots per ms when the upstream data rate is 6,176 Mbit/s, there are 18 upstream minislots per ms when the upstream data rate is 3,088 Mbit/s, there are 9 upstream minislots per ms when the upstream data rate is 1,544 Mbit/s, and there are 1,5 upstream minislots per ms when the upstream data rate is 256 kbit/s. The corresponding upstream minislot rates are, therefore, 36 000 upstream minislots/s when the upstream data rate is 6,176 Mbit/s, 18 000 upstream minislots/s when the upstream data rate is 3,088 Mbit/s, 9 000 upstream minislots/s when the upstream data rate is 1,544 Mbit/s, and 1 500 upstream minislots/s when the upstream data rate is 256 kbit/s. The algorithm to determine the upstream slot position counter value is given below.

For 16QAM modulation, there are 36 upstream minislots per ms when the upstream data rate is 12,352 Mbit/s, there are 18 upstream minislots per ms when the upstream data rate is 6,176 Mbit/s, there are 9 upstream minislots per ms when the upstream data rate is 3,088 Mbit/s, and there are 1,5 upstream minislots per ms when the upstream data rate is 512 kbit/s. The corresponding upstream minislot rates are, therefore, 36 000 upstream minislots/s when the upstream data rate is 12,352 Mbit/s, 18 000 upstream minislots/s when the upstream data rate is 6,176 Mbit/s, 9 000 upstream minislots/s when the upstream data rate is 3,088 Mbit/s, and 1 500 upstream minislots/s when the upstream data rate is 512 kbit/s.

In the case of OOB downstream, the algorithm to determine the upstream slot position counter value is given below:

```
if (downstream_rate == 3,088 Mbit/s) {n = 1;}
else {n = 0;}
```

```
upstream_slot_position_register = value of M-bits latched at bit_position M11 (M10 - M1)
```

```
if (upstream_rate == 1,544 Mbit/s) {m = 3;}
else if (upstream_rate == 3,088 Mbit/s) {m = 6;}
    else if (upstream_rate == 6,176 Mbit/s) {m = 12;}
        else {m = 0,5}
```

```
if (bit_position == M1 and previous M12 == 1)
    {upstream_slot_position_counter = upstream_slot_position_register × 3 × m;}
if (bit_position == M5)
    if ( (n == 0) or (n == 1 and previous M12 == 0) )
        {upstream_slot_position_counter = upstream_slot_position_counter + m;}
if (bit_position == M9)
    if ( (n == 0) or (n == 1 and previous M12 == 1) )
        {upstream_slot_position_counter = upstream_slot_position_counter + m;}
if (bit_position == M11)
    {temp_upstream_slot_position_register = (M10, M9, M8, ..., M1);}
if ( (bit_position == M12 and M12 == 1) )
    {upstream_slot_position_register = temp_upstream_slot_position_register;}
```

where the M-bits will be defined as follows:

- M1 - M10 = 10 bit ESF counter which counts from 0 to N with M10 the most significant bit (MSB);
- M11 = odd parity for the ESF counter, i.e., M11 = 1 if the ESF Counter (M1-M10) has an even number of bits set to 1;
- M12 = 1: ESF counter valid  
0; ESF counter not valid

The values assigned to M12 are as follows:

- 1) When the QPSK downstream channel bit rate is 1,544 Mbit/s, the M12 bit, is always set to the value '1'.
- 2) When the QPSK downstream channel bit rate is 3,088 Mbit/s, the information is always transmitted in pairs of superframe, where superframe-A is the first superframe in the pair, and superframe-B is the second superframe in the pair. In this case, the M12 bit of superframe-A is set to the value '0' and the M12 bit of superframe-B is set to the value '1'.
- 3) When the downstream channel is IB, M12 = 1.

In the case of IB downstream, the upstream slot timing should mimic that of the OOB downstream.

## 5.5 MAC Functionality

### 5.5.1 MAC Reference Model

The scope of this clause is limited to the definition and specification of the MAC Layer protocol. The detailed operations within the MAC layer are hidden from the above layers.

This clause focuses on the required message flows between the INA and the NIU for Media Access Control. These areas are divided into three categories: Initialization, Provisioning and Sign On Management, Connection Management and Link Management.

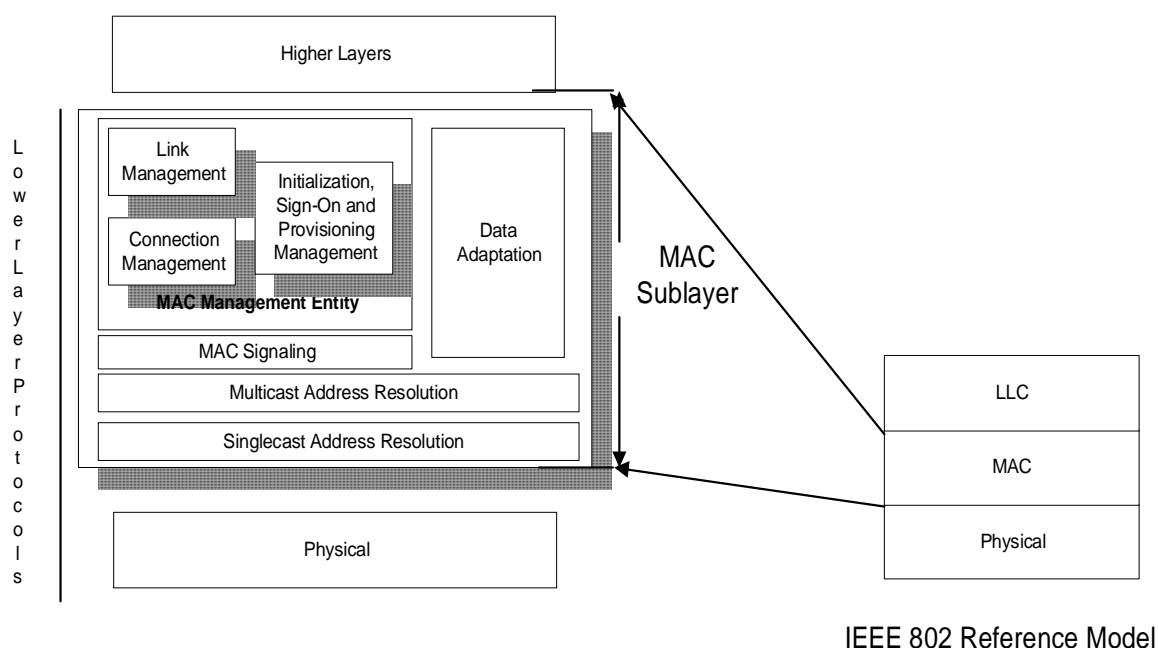

Figure 29: MAC Reference Model

## 5.5.2 MAC Concept

### 5.5.2.1 Relationship Between Higher Layers and MAC Protocol

The goal of the MAC protocol is to provide tools for higher layer protocols in order to transmit and receive data transparently and independently of the physical layer. Higher layer services are provided by the INA to the STU. The INA is thus responsible of indicating the transmission mode and rate to the MAC layer for each type of service.

Specifically, for each connection provided by higher layers on the INA side (VPI/VCI), a connection ID is associated at the MAC layer. The maximum number of simultaneous connections that a NIU should support is defined as follows:

- Level A: Only one connection at a time can be handled by a NIU;
- Level B: As many connections as needed, defined dynamically by the INA, following higher layers requests.

NOTE 1: Note that in this case all connections should be assigned to the same frequency upstream and downstream for implementation reasons.

NOTE 2: However bandwidth (time slots) does not need to be assigned immediately by the INA for a given connection. This means that a connection ID may exist at the NIU side without associated slot numbers.

The INA is responsible of providing transmission bandwidth to the NIUs when needed by higher layers. However, since the NIU shall transmit all data from the STU, the NIU is also responsible for requesting for more bandwidth if not already provided by the INA.

An initial connection is allocated to the STB by the INA, following the successful completion of sign-on at power up. This connection can be used to send data from higher layers leading to further interactive connections. Note that this connection can be associated to a zero transmission rate (no initial bandwidth allocation).

### 5.5.2.2 Relationship Between Physical Layer and MAC Protocol

Up to 8 Upstream channels can be related to each downstream channel which is designated as a MAC control channel. These upstream channels can be used in different, physically separated coaxial cells where space division multiplexing (SDM) is applied or within a single cell where frequency division multiplexing (FDM) is applied. Mixed scenarios where space and frequency division multiplexing is applied in either upstream or downstream direction are also possible. Network scenarios showing when to apply SDM or FDM can be found in [17]. An example of a frequency allocation for the FDM scenario is shown in Figure 30. This relationship consists of the following items:

- 1) Each of these related upstream channels share a common slot position. This reference is based on 1 ms time markers in case of OOB and 3 ms time markers in case of IB that are derived via information transmitted via the downstream MAC control channel.
- 2) Each of these related upstream channels derive slot numbers from information provided in the downstream MAC control channel.
- 3) The Messaging needed to perform MAC functions for each of these related upstream channels is transmitted via the downstream MAC control channel.

The Media Access Control Protocol supports multiple downstream Channels. In instances where multiple Channels are used, the INA shall specify a single OOB frequency called the Provisioning Channel, where NIUs' perform Initialization and Provisioning Functions. If both 1,544 Mbit/s and 3,088 Mbit/s downstream OOB channels co-exist on the network, there should be one provisioning channel with each rate. Also, in networks where IB NIUs exist, provisioning should be included in at least one IB channel. An a periodic message is sent on each downstream control channel which points to the downstream Provisioning Channel. In instances where only a single frequency is in use, the INA shall utilize that frequency for Initialization and Provisioning functions.

The Media Access Control protocol supports multiple upstream channels.

There are 2 types of upstream channels:

- Upstream channels that support only QPSK modulation.
- Upstream channels that support only 16QAM modulation.

The INA is responsible for classifying the different channels according to the INA and NIU capabilities.

INAs that support only QPSK modulation will allocate only QPSK channels. All NIUs regardless of their capabilities will use the QPSK channels with QPSK modulation.

INAs that support 16QAM modulation will allocate QPSK channels and 16QAM channels. NIUs that support 16QAM modulation should use the 16QAM upstream channels (but the INA is permitted to assign them to QPSK channels). NIUs that support only QPSK modulation will use only QPSK upstream channels.

One of the available upstream channels shall be designated the Service Channel. The service channel (and backup service channel) will use QPSK modulation. It may be necessary to provide a Backup Service Channel to make the system more reliable e.g. in a noisy environment. The Service Channel and the Backup Service Channel, respectively, shall be used by NIUs' entering the network via the Initialization and Provisioning procedure. The remaining upstream channels shall be used for upstream data transmission. In cases where only one upstream channel is utilized, the functions of the Service Channel shall reside in conjunction with regular upstream data transmission.

The Provisioning channel is the frequency channel on which the Default configuration message is transmitted. There can be several Provisioning channels in the system.

The Service channel is the frequency channel to which the Default configuration message field Service channel frequency points. The ranging following the Default configuration message is carried out on that Service channel. There can be several Service channels in the system.

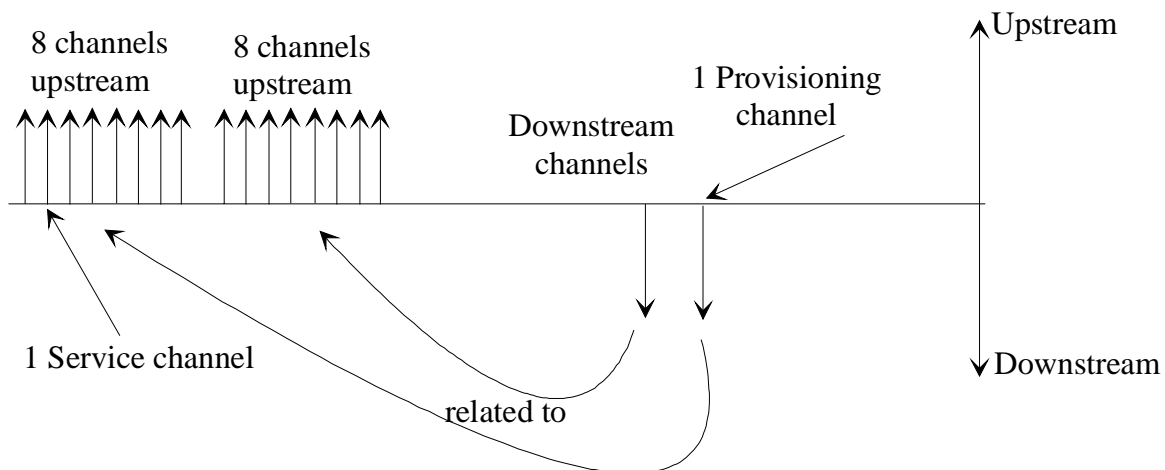

**Figure 30: Example of a frequency allocation for the FDM scenario**

### Upstream frequency change

All connections of a NIU are on the same frequency channel. The upstream frequency can be changed by Reprovision or Transmission control message (see clauses 5.5.10.2 and 5.5.10.4). If any of these messages change the frequency, the frequency is changed immediately, all connections remain established in any case.

When no `stop_upstream_transmission` command was given before or in the Reprovision or Transmission control message, sign-on is entered immediately after the upstream frequency change, reservation grants are lost and fixed rate slots are kept. (If the frequency change was made by the <MAC> Transmission Control Message, the fixed rate slot assignments remain the same. If the frequency change was made by the <MAC> Reprovision Message, the fixed rate slot assignments remain the same except if new slot assignments are provided in this message.)

When a `stop_upstream_transmission` command was given, sign-on is performed after a `start_upstream_transmission` command is received, reservation grants are lost and fixed rate slots are kept.

If any of the parameters: `Upstream_Channel_Number`, `Upstream_Rate` or `MAC_Flag_Set` has been changed, reservation grants as well as fixed rate slots are lost, the connection is still kept.

## Downstream frequency channel types

**Table 15: Possible combinations of downstream content types and physical channels (NIU Capabilities)**

Case	MAC		Data	
	OOB	IB	QPSK	QAM
1	X		X	
2	X			X
3	X		X	X
4		X		X

There are three types of content in the downstream direction MAC messages and MAC flags, data and video. There can be two types of physical channels: QPSK and QAM downstream channels. The QAM downstream channel may carry either MPEG or MAC messages directly on the physical layer frame structure. The possible combinations of the content and physical channels are shown in Table 15.

### Combination establishment

The NIU tunes to either a QPSK or QAM channel on which it locates the provisioning channel. The NIU tunes to it and gets its MAC information on that channel. If the Connect message gives a new downstream frequency, the MAC information is found on that frequency, if it is the same type of frequency channel.

### Change of downstream frequency

The downstream frequency can be changed by using either Reprovision or Transmission control message (see clauses 5.5.10.2 and 5.5.10.4). All NIUs' connections which use the same physical frequency channel (DS QPSK or DS QAM) are located on the same frequency. When the downstream frequency changes the connections on the earlier downstream frequency remain established in any case.

When no stop\_upstream\_transmission command was given before or in the Reprovision or Transmission control message, no sign-on is performed, reservation grants are lost and fixed rate slots are kept.

When a stop\_upstream\_transmission command was given, sign-on is performed after a start\_upstream\_transmission command, reservation grants are lost and fixed rate slots are kept.

### Change of combination

The combination can be changed with Connect message only immediately after the sign-on procedure or with Reprovision message at any time. The signalling channel cannot be changed to a different type of downstream channel.

### 5.5.2.3 Relationship Between Physical Layer Slot Position Counter and MAC Slot Assignment

M10 - M1 is a 10-bit superframe counter at the INA side, whereas the upstream slot position counter is an upstream slot counter at the NIUs side. The NIU slot position counter ( $M10 - M1 \times 3 \times m$ , where  $m = 0,5$  for 256 kbit/s,  $m = 3$  for 1,544 Mbit/s,  $m = 6$  for 3,088 Mbit/s and  $m = 12$  for 6,176 Mbit/s) may be implemented as a 16-bit counter which is compared to the 13-bit slot numbers assigned by the INA in MAC messages (list assignment). When the counter value equals any assigned value, the NIU is allowed to send a packet upstream.

#### 5.5.2.4 Access Modes (Contention/Ranging/Fixed rate/Reservation)

Different access modes are provided to the NIUs within access regions specified by information contained in the slot boundary fields of the downstream superframes. The limits between access regions allow users to know when to send data on contention without risks of collision with data of Reservation or Fixed Rate regions. Also, the separation between reservation and fixed rate regions provides two ways of assigning slots to NIUs. The following rules define how to select access modes:

- Data connections:

When the INA assigns a connection ID to the NIU, it either specifies a slot list to be used (Fixed rate access) or the NIU shall use contention or reserved access by following this algorithm:

When the NIU shall send more upstream packets for a specific VPI/VCI than what was assigned by the INA, it can use contention access only if the number of upstream packets to transmit is less than `Maximum_contention_access_message_length` (specified in the MAC Connect Message from the INA). The details of the contention access mechanism is explained below under a). The NIU can send one request for reservation access if the number of upstream packets is less than `Maximum_reservation_access_message_length` (specified in the MAC Connect Message from the INA). If more upstream packets shall be transmitted, the NIU shall send multiple requests for reservation access. If the NIU/STB is forced to use reservation access, and it has not yet been assigned a `Reservation_ID`, then it shall wait for an assignment before transmitting.

- MAC messages:

MAC messages can be sent on contention access, reservation access, fixed rate access or ranging access (ranging access is only allowed for calibration purposes).

Note that the VPI/VCI=0x00/0x0021 connection used for MAC messages is always set up, so the INA does not assign a particular connection ID which is normally used for reservation requests. Thus, in order to use reservation access, slots assigned for other connections may be used for MAC messages.

##### a) Contention Access

`Contention Access` indicates that data (MAC or bursty data traffic) is sent in the slots assigned to the contention access region in the upstream channel. It can be used either to send MAC messages or data. The VPI, VCI of the ATM cells are then used to determine the type and direction of the data in higher layers. Contention based access provides instant channel allocation for the NIU.

The Contention based technique is used for multiple subscribers that will have equal access to the signalling channel. It is possible that simultaneous transmissions occur in a single slot, which is called a collision. The INA utilizes the reception indicators to inform the NIUs' whether successful reception of upstream packets has been obtained.

The NIU executes a separate contention process for each VPI/VCI connection that requires contention access. The contention process is initiated by transmitting the first upstream packet in a contention slot. This contention slot is randomly chosen from the available contention slots in the first frame that contains at least one contention slot. The contention process has to wait until the reception indicator of the slot is received. If the indicator contains a positive acknowledgement, the upstream packet has been successfully received, and the next upstream packet, if present, can be transmitted by continuing the contention process. If the indicator contains a negative acknowledgement, a collision has been detected and the upstream packet can be retransmitted according to the procedure defined below. If the reception indicator is not received (e.g. due to CRC error), the NIU proceeds as if a positive acknowledgement would have been received.

If a collision has occurred the NIU is not obliged to retransmit the upstream packet that was originally transmitted. Instead it may choose to update the contents of the upstream packet, transmit another upstream packet belonging to the same VPI/VCI connection, or not to retransmit at all. In the latter case, the NIU is not allowed to restart a contention process for the same VPI/VCI connection at an earlier slot than the latest possible contention slot in which it could have retransmitted the upstream packet in the first contention process. Note that the allowed choices make it possible for the NIU to update the queue status when the upstream packet to be retransmitted contains a grant request.



A counter at the /STB records the number, denoted by `backoff_exponent`, of collisions encountered by an upstream packet. The `backoff_exponent` counter starts from a value determined by the `Min_Backoff_Exponent` variable. The `backoff_exponent` is used to generate a uniform random number between 1 and  $2^{\text{backoff\_exponent}}$ . This random number is used to schedule retransmission of the collided upstream packet. In particular, the random number indicates the number of contention access slots the /STB shall wait before it transmits. The first transmission is carried out in a random slot within the contention based access region. If the counter reaches the maximum number, determined by the `Max_Backoff_Exponent` variable, the value of the counter remains at this value regardless of the number of subsequent collisions. After a successful transmission the `backoff_exponent` counter is reset to a value determined by the `Min_Backoff_Exponent` variable. Informational Statement: The random access algorithm is unstable; the INA is expected to have intelligence to detect an unstable state of the random access algorithm and to solve it.

For minislots contention resolution refer to clause 5.7.3.

#### b) Ranging Access

`Ranging access` indicates that the data is sent in a slot preceded and followed by slots not used by other users. These slots allow users to adjust their clock depending on their distance to the INA such that their slots fall within the correct allocated time. They are either in the ranging slots region when the ranging control slot indicator `b0` received during the previous superframe was 1 (or when `b1-b6 = 55 to 63`), or reserved if the INA indicates to the NIU that a specific slot is reserved for ranging (via the Ranging and Power Calibration Message). In the latter case, the NIU is forbidden from ranging in the ranging slots region before the assigned slot appears.

Simultaneous transmissions in ranging slots are resolved through the procedure defined in clause A.1.

#### c) Fixed rate Access

NOTE: Fixed rate is called contentionless in DAVIC.

`Fixedrate_Access` indicates that data is sent in slots assigned to the fixed rate based access region in the upstream channel. These slots are uniquely assigned to a connection by the INA. It is not allowed that the INA changes the boundary fields such that an assigned fixed rate slot does not fit anymore in the fixed slot region.

#### d) Reservation Access

`Reservation Access` implies that data is sent in the slots assigned to the reservation region in the upstream channel. These slots are uniquely assigned once to a connection by the INA. This assignment is made at the request of the NIU for a given connection. It is also allowed to use such assignment in the fixed rate region. One reservation grant only grants consecutive slots in the same type of region. Requests are indicated via a request message in a contention slot, in a contention minislots, in a reserved slot, in a fixed rate slot or via the Piggybacking mechanism.

### 5.5.2.5 MAC Error Handling Procedures

Error handling procedures are under definition (Time out windows, power outage, etc.). An informative note on some error handling procedures can be found in annex A.

### 5.5.2.6 MAC Messages in the Mini Slots

MAC reservation request messages may also be transported in the minislots structure. For 16QAM modulation, the framing of the minislots Reservation Requests is described in clause 5.6.2. For QPSK modulation, it is described in clause 5.6.2 and in the following.

Error correction and/or detection is performed using a 2 byte Reed Solomon code. For QPSK modulation, Reed-Solomon encoding shall be performed on the 14 bytes following the Unique Word with  $T=1$  (see Figure 31). For 16QAM modulation, Reed-Solomon encoding shall be performed on the 9 bytes following the Unique Word with  $T=1$  (see Figure 32). This process adds 2 parity bytes to the MAC Message in the Minislots to give a code word of (16,14) for QPSK modulation and (11,9) for 16QAM modulation. Reed-Solomon encoding is performed on the MAC Message in the Minislots before upstream data randomization. The shortened Reed-Solomon code shall be implemented by appending 239 bytes for QPSK modulation (244 for 16QAM modulation), all set to zero, before the information bytes at the input of a (255,253) encoder; after the coding procedure these bytes are discarded.

The Reed-Solomon code shall have the following generator polynomials:

$$\text{Code Generator Polynomial: } g(x) = (x + \mu^0)(x + \mu^1)$$

where  $\mu = 02\text{hex}$

$$\text{Field Generator Polynomial: } p(x) = x^8 + x^4 + x^3 + x^2 + 1$$

For QPSK modulation, the Start Field (SF) for the QPSK minislot MAC messages is defined in Figure 31. The SF byte, the 13 payload bytes and the 2 RS bytes of the minislots are randomized and differentially encoded as defined for upstream ATM cells, whereas the unique word is sent in clear and not differentially encoded.

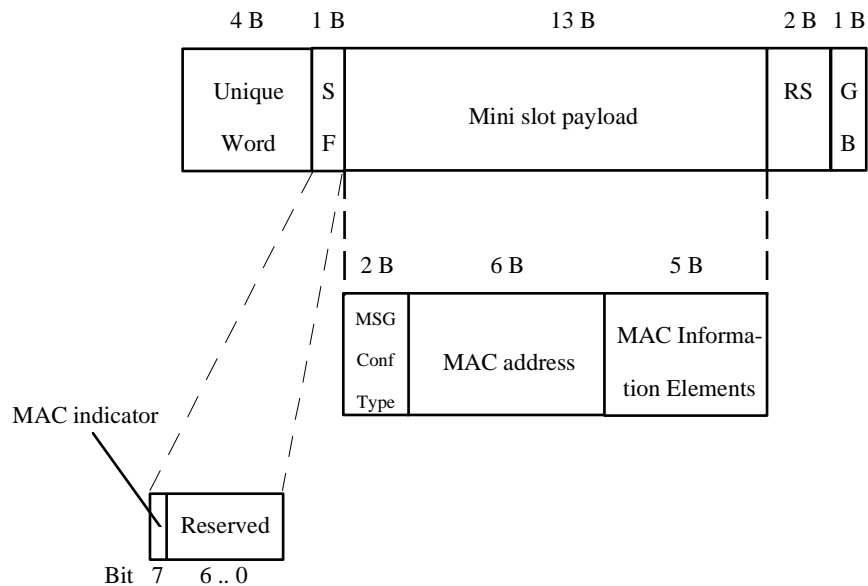

**Figure 31: MAC messages in the QPSK minislots**

Unique Word = 0xCCCCCC0E

SF = Start Field (Bit 7: MAC indicator, always set to 1; Bit 6 ... 0: reserved, shall be set to zero)

RS = Reed Solomon Bytes

GB = Guard Band

For 16QAM modulation, the minislot format is described in Figure 32.

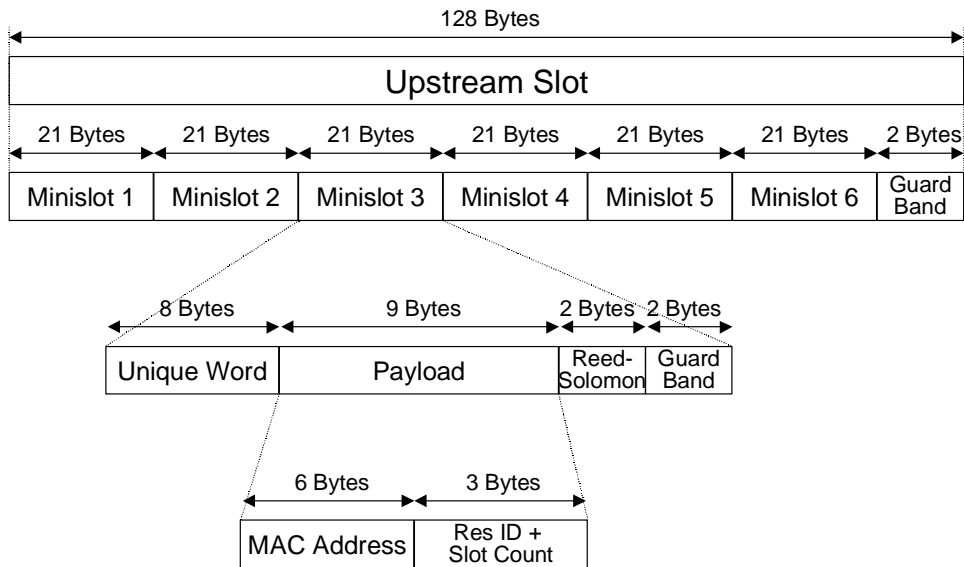

**Figure 32: MAC messages in the 16QAM minislots**

Unique Word = 0xF3F3F3F3F3F333FB

RS = Reed Solomon Bytes

GB = Guard Band

**Reservation Request Message**

For QPSK modulation, the Reservation Request Message has the same structure as in the case it is transported in an upstream ATM cell. The MAC message structure for carrying the Reservation Request Message is shown in Figure 33.

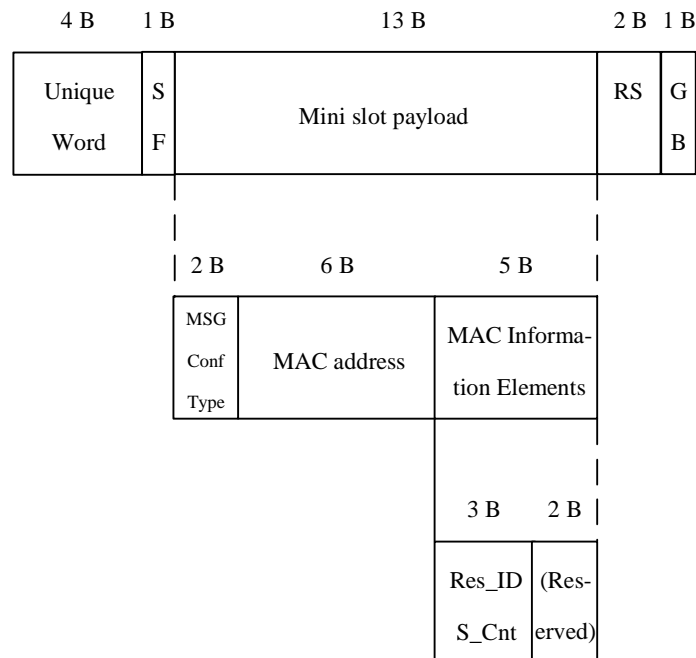

**Figure 33: Reservation Request Message in the QPSK minislot MAC message structure**

For 16QAM, the reservation request format is described in Figure 32.

### 5.5.2.7 MAC Message Format

The MAC message types are divided into the logical MAC states of Initialization, Sign On, Connection Management and Link Management. MAC messages are sent using Broadcast or Singlecast Addressing. Singlecast addressing shall utilize the 48-bit MAC address.

Regardless of the INA/NIU support for 16QAM modulation, the initialization, provisioning sign on and calibration messages (initial calibration) will be sent using QPSK modulation. In case the INA/NIU support 16QAM modulation, and the NIU uses an upstream channel with 16QAM modulation, all the following messages will be sent using 16QAM modulation.

**Table 16: MAC messages**

Message Type Value		Transmit Direction	Addressing Type
<b>MAC Initialization, Provisioning and Sign-On Messages</b>			
0x00	Used for fragmented messages (continued message)	up-/downstr.	Scast or Bcast
0x01	Provisioning Channel Message	downstream	Broadcast
0x02	Default Configuration Message	downstream	Broadcast
0x03	Sign-On Request Message	downstream	Broadcast
0x04	Sign-On Response Message	upstream	Singlecast
0x05	Ranging and Power Calibration Message	downstream	Singlecast
0x06	Ranging and Power Calibration Response Message	upstream	Singlecast
0x07	Initialization Complete Message	downstream	Singlecast
0x08-0x0B	[Reserved]		
0x0C	Security Sign-on (see note)	downstream	Singlecast
0x0D	Security Sign-on Response (see note)	upstream	Singlecast
0x0E-0x1E	[Reserved]		
0x1F	Wait (see note)	upstream	Singlecast
<b>MAC Connection Establishment and Termination Msgs</b>			
0x20-0x3F			
0x20	Connect Message	downstream	Singlecast
0x21	Connect Response Message	upstream	Singlecast
0x22	Reservation Request Message	upstream	Singlecast
0x23	Unused		Broadcast
0x24	Connect Confirm Message	downstream	Singlecast
0x25	Release Message	downstream	Singlecast
0x26	Release Response Message	upstream	Singlecast
0x28	Reservation Grant Message	downstream	Broadcast
0x29	Reservation ID Assignment	downstream	Singlecast
0x2A	Reservation Status Request	upstream	Singlecast
0x2B	Reservation ID Response Message	downstream	Singlecast
0x2C	Resource Request Message	upstream	Singlecast
0x2D	Resource Request Denied Message	downstream	Singlecast
0x2E	Suppression Data Message	up-/downstr.	Singlecast
0x2F	Suppression Acknowledgment Message	up-/downstr.	Singlecast
0x30	Main Key Exchange (see note)	downstream	Singlecast
0x31	Main Key Exchange Response (see note)	upstream	Singlecast
0x32	Quick Key Exchange (see note)	downstream	Singlecast
0x33	Quick Key Exchange Response (see note)	upstream	Singlecast
0x34	Explicit Key Exchange (see note)	downstream	Singlecast
0x35	Explicit Key Exchange Response (see note)	upstream	Singlecast
0x36-0x3F	[Reserved]		
<b>MAC Link Management Messages</b>			
0x27	Idle Message	upstream	Singlecast
0x40	Transmission Control Message	downstream	Scast or Bcast
0x41	Reprovision Message	downstream	Singlecast
0x42	Link Management Response Message	upstream	Singlecast
0x43	Status Request Message	downstream	Singlecast
0x44	Status Response Message	upstream	Singlecast
0x45-0x5F	[Reserved]		
NOTE: Optional MAC messages for the security option.			

To support the delivery of MAC related information to and from the NIU, a dedicated Virtual Channel shall be utilized. The VPI, VCI for this channel shall be 0x00/0x0021. MAC Messages shall not be encrypted. Therefore, any ATM cell carrying a MAC Message shall have the least significant two bits of its GFC field set to 00. The most significant two bits of the GFC field are reserved for future use, and shall be set to 00.

The timer accuracy of the MAC messages shall be  $\pm 3$  ms in the NIU, and the INA shall take this into account.

- Upstream MAC messages:

AAL5 (as specified in ITU-T Recommendation I.363 [2]) adaptation shall be used to encapsulate each MAC PDU in an ATM cell. Upstream MAC information should be single 40 bytes cell messages.

- Downstream OOB MAC messages:

AAL5 (as specified in ITU-T Recommendation I.363 [2]) adaptation shall be used to encapsulate each MAC PDU in an ATM cell. Downstream OOB MAC information may be longer than 40 bytes. All Downstream MAC messages shall be restricted to less than or equal to 120 bytes.

- Downstream IB MAC messages:

Downstream IB MAC messages are limited to a size of 120 bytes and shall be carried in a single MPEG TS packet. Longer messages shall be split into separate messages. No AAL5 layer is defined for MPEG-2 TS packets. MAC messages shall therefore be sent as explained in clause 5.3.2 using the three MAC Message Framing bits.

- MAC Fragmentation Protocol (optional):

Larger MAC messages up to 512 bytes may optionally be supported using the MAC fragmentation protocol. This capability is indicated by the NIU in the MAC\_Sign\_On\_Response.

A multi-fragment MAC message is composed of consecutive individual MAC messages with Syntax\_Indicator equal to Fragment\_No\_MAC\_Address or Fragment\_MAC\_Address\_Included.

The Fragment\_Count field of each individual MAC message indicates the number of fragments remaining of the full message, decreasing by one for each consecutive fragment. Thus the first fragment has Fragment\_Count equal to the total number of fragments in the message, and the last fragment has Fragment\_Count == 1.

Furthermore, the type of MAC message is indicated by the Message\_Type field of the first fragment, whereas all subsequent fragments have Message\_Type == 0.

The sender of a fragmented MAC message shall not interleave any other fragmented MAC messages for the same receiver into the string of fragments. This includes any fragmented broad-cast MAC messages, which shall therefore not be sent while there are any incomplete fragmented messages outstanding.

MAC messages of unfragmented syntax type can be interleaved with fragments destined for the same NIU. They are deemed to have arrived before the fragmented message, and should be processed immediately.

The receiver of a fragmented MAC message shall discard any message with missing fragments, as implied by the uniformly decreasing Fragment\_Count field in consecutive fragments. Likewise, it shall discard any stray fragments with Message\_Type == 0, for instance in the case where the first fragment was lost during transport.

The length of each fragment is implied by its transport context: ATM/AAL-5 for upstream and OOB downstream, MPEG encapsulation for IB downstream, etc.

The MAC\_Information\_Elements fields of each fragment are concatenated to form the MAC\_Information\_Elements field of the full MAC message. The message type is conveyed in the first fragment.

In the upstream direction, all fragments shall be of syntax type Fragment\_MAC\_Address\_Included, in order to allow the INA to use the MAC address to distinguish inter-mixed MAC messages and fragments coming from separate NIUs.

For a broad-cast in the downstream direction, each fragment is of syntax type `Fragment_No_MAC_Address`. For a single-cast downstream message, the first fragment shall be of syntax type `Fragment_MAC_Address_Included`, and include the MAC address of the target NIU. Subsequent fragments can also include the same MAC address value, or can be `Fragment_No_MAC_Address`, omitting the MAC address, when the INA ensures that the fragment is associated with the immediately preceding fragment in the transport stream, that is, not separated by messages or fragments for other NIUs.

Since MAC related information is terminated at the NIU and INA, a privately defined message structure will be utilized. The format of this message structure is illustrated below.

NOTE 1: All messages are sent most significant bit first.

NOTE 2: For all MAC messages where the parameter length is smaller than the field, the parameter shall be right justified with leading bits set to 0. All reserved fields in the MAC messages shall be set to 0.

NOTE 3: Message 0x23 is not used in the present release of the MAC protocol. It refers to DAVIC 1.0 protocol which is not supported by the present document.

NOTE 4: When no `MAC_Address` is specified in the message, it means that the message is sent broadcast. (`Syntax_indicator = 000`).

NOTE 5: Negative integers are sent in 2's complement.

**Table 17: MAC message structure**

<b>MAC_message(){</b>	<b>Bits</b>	<b>Bytes</b>	<b>Bit Number / Description</b>
<b>Message Configuration</b>		<b>1</b>	
Protocol_Version	5		
Syntax_Indicator	3		
<b>Message_Type</b>	<b>8</b>	<b>1</b>	
<i>if (Syntax_Indicator == 001    Syntax_Indicator == 011) {</i>			
<b>MAC_Address</b>	<b>(48)</b>	<b>(6)</b>	
<i>}</i>			
<i>if (Syntax_Indicator == 010    Syntax_Indicator == 011) {</i>			
<b>Reserved</b>	<b>(8)</b>	<b>(1)</b>	
<b>Fragment_Count</b>	<b>(8)</b>	<b>(1)</b>	
<i>}</i>			
<b>MAC_Information_Elements ()</b>		<b>N</b>	
<b>}</b>			

### MAC Information Elements

`MAC_Information_Elements` is a multiple byte field that contains the body of one and only one MAC message.

### Protocol Version

`Protocol_Version` is a 5-bit field used to identify the current MAC version. The value for this parameter is given in Table 18.

**Table 18: Protocol\_version coding**

Value	Definition
0	DAVIC 1.0 Compliant device (not consistent with the present document)
1	DAVIC 1.1 Compliant device
2	DAVIC 1.2 Compliant device
3-19	Reserved
20	EN 301 199 [18] compliant device
21-28	Reserved
29	ETS 300 800 V2 and DAVIC 1.5 compliant device
30	ETS 300 800 V1 compliant device
31	Reserved

### Syntax Indicator

`Syntax_Indicator` is a 3-bit enumerated type that indicates the addressing type contained in the MAC message.

Enum `Syntax_Indicator` {`No_MAC_Address`, `MAC_Address_Included`, `Fragment_No_MAC_Address`, `Fragment_MAC_Address`, reserved 4...7};

### MAC Address

`MAC_Address` is a 48-bit value representing the unique MAC address of the NIU. This MAC address may be hard coded in the NIU or be provided by external source.

### Fragment\_Count

Identification of fragment in a MAC message transmitted in multiple fragments. A MAC Message divided into N fragments, will be transmitted with `Fragment_Count` = N, N-1, ... 1.

## 5.5.3 MAC Initialization and Provisioning

This clause defines the procedure for Initialization and Provisioning that the MAC shall perform during power on or Reset. All INA/NIU will send and receive the messages during initialization and provisioning using QPSK modulation.

- 1) Upon a NIU becoming active (i.e. powered up), it shall first find the current provisioning frequency. The NIU shall receive the **<MAC> Provisioning Channel Message**. This message shall be sent aperiodically (at least one in 900 ms) on all downstream channels carrying MAC information when there are multiple channels. In the case of only a single channel, the message shall indicate the current channel is to be utilized for Provisioning. Upon receiving this message, the NIU shall tune to the Provisioning Channel. In the case of IB downstream, the IB channel to be used during provisioning can additionally be given by using EN 300 468 [21].
- 2) After a valid lock indication on a Provisioning Channel, the NIU shall await the **<MAC> DEFAULT CONFIGURATION MESSAGE**. When received, the NIU shall configure its parameters as defined in the default configuration message. The Default Configuration Parameters shall include default timer values, default power levels, default retry counts as well as other information related to the operation of the MAC protocol.

Figure 34 shows the signalling sequence.

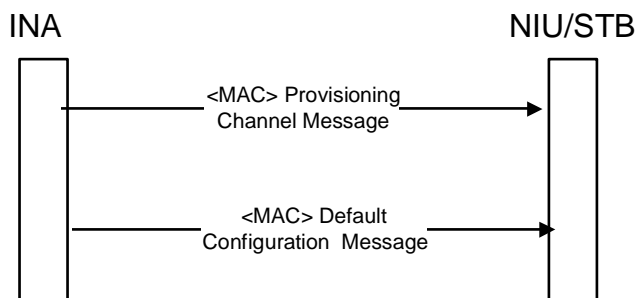

**Figure 34: Initialization and Provisioning signalling**

### 5.5.3.1 <MAC> Provisioning Channel Message (Broadcast Downstream)

The <MAC> PROVISIONING CHANNEL MESSAGE is sent by the INA to direct the NIU to the proper frequency where provisioning is performed. The format of the message is shown in Table 19.

**Table 19: Provisioning Channel Message Structure**

Provisioning_Channel_Message(){	Bits	Bytes	Bit Number/Description
<b>Provisioning_Channel_Control_Field</b>	8	1	
Reserved	7		7-1
Provisioning_Frequency_Included	1		0: {no=0, yes=1}
<i>if (Provisioning_Frequency_Included) {</i>			
<b>Provisioning_Frequency</b>	<b>(32)</b>	<b>(4)</b>	
<b>DownStream_Type</b>	<b>(8)</b>	<b>(1)</b>	
}			
}			

#### Provisioning Channel Control Field

Provisioning\_Channel\_Control\_Field is used to specify which parameters are included in the message:

Provisioning\_Frequency\_Included is a boolean when set, indicates that a downstream frequency is specified that the NIU should tune to begin the provisioning process. When cleared, indicates that the current downstream frequency is the provisioning frequency.

#### Provisioning Frequency

Provisioning\_Frequency is a 32-bit unsigned integer representing the Out-of-band Frequency in which NIU provisioning occurs. The unit of measure is Hertz.

#### Downstream Type

DownStream\_Type is an 8-bit enumerated type indicating the modulation format for the down stream connection. {QAM\_MPEG, QPSK\_1,544, QPSK\_3,088, 3...255 reserved} }

### 5.5.3.2 <MAC> Default Configuration Message (Broadcast Downstream)

The <MAC> DEFAULT CONFIGURATION MESSAGE is sent by the INA to the NIU. The message provides default parameter and configuration information to the NIU. The format of the message is shown in Table 20.



Table 20: Default configuration message structure

Default_Configuration_Message(){	Bits	Bytes	Bit Number/ Description
<b>Sign_On_Incr_Pwr_Retry_Count</b>	<b>8</b>	<b>1</b>	
<b>Service_Channel_Frequency</b>	<b>32</b>	<b>4</b>	
<b>Service_Channel_Control_Field</b>		<b>1</b>	
MAC_Flag_Set	5		7...3
Service_Channel	3		2...0
<b>Backup_Service_Channel_Frequency</b>	<b>32</b>	<b>4</b>	
<b>Backup_Service_Channel_Control_Field</b>		<b>1</b>	
Backup_MAC_Flag_Set	5		7...3
Backup_Service_Channel	3		2...0
<b>Service_Channel_Frame_Length</b>	<b>16</b>	<b>2</b>	
<b>Service_Channel_Last_Slot</b>	<b>16</b>	<b>2</b>	
<b>Max_Power_Level</b>	<b>8</b>	<b>1</b>	
<b>Min_Power_Level</b>	<b>8</b>	<b>1</b>	
<b>Upstream_Control_Field</b>		<b>1</b>	
Reserved	5		7...3
Upstream_Transmission_Rate	3		2...0
<b>Max_Backoff_Exponent</b>	<b>8</b>	<b>1</b>	
<b>Min_Backoff_Exponent</b>	<b>8</b>	<b>1</b>	
<b>Idle_Interval</b>	<b>16</b>	<b>2</b>	
<b>Absolute_Time_Offset</b>	<b>16</b>	<b>2</b>	
<b>frequency_ranging_step</b>	<b>8</b>	<b>1</b>	
<b>Number_of_Timeouts</b>	<b>8</b>	<b>1</b>	
for (l=0; l<Number_of_Timeouts;l++) {			
<b>Field</b>		<b>(1)</b>	
<b>Code</b>	(4)		
<b>Value</b>	(4)		
}			
<b>INA_Capabilities</b>		<b>4</b>	
Encapsulation	8		31...24
US_Bitrate	8		23...16
DS_OOB_Bitrate	4		15...12
Capabilities_extended_included	1		11: {no, yes}
Reserved	1		10: shall be 0
DS_Header_Suppression	1		9: {no, yes}
US_Header_Suppression	1		8: {no, yes}
Piggy_Back_Capable	1		7: {no, yes}
Resource_Request_Capable	1		6: {no, yes}
Fragmented_MAC_Messages	1		5: {no, yes}
Security_Supported	1		4: {no, yes}
Minislots_for_Reservation	1		3: {no, yes}
Reserved_for_DAVIC	1		2: shall be 0
IB_Signalling	1		1: {no, yes}
OOB_Signalling	1		0: {no, yes}
if (INA_capabilities &= Capabilities_extended_included )			
{			
<b>INA_capabilities_extended</b>		<b>4</b>	
Reserved	30		31...3: shall be 0
Session_binding	1		2:{no,yes}
16QAM_minislots	1		1: {no, yes}
16QAM	1		0: {no, yes}
}			
}			

### Sign-On Increment Power Retry Count

*Sign\_On\_Incr\_Pwr\_Retry\_Count* is an 8-bit unsigned integer representing the number of attempts the NIU should try to enter the system at the same power level before incrementing its power level by steps of max. 2 dB.

### Service Channel Frequency

`Service_Channel_Frequency` is a 32-bit unsigned integer representing the upstream frequency assigned to the service channel. The unit of measure is in Hertz.

### **MAC\_Flag\_Set**

`MAC_Flag_Set` is a 5-bit field representing the first Flag set assigned to the service channel. A downstream channel contains information for each of its associated upstream channels. This information is contained within structures known as MAC Flag Sets represented by either 24 bits (denoted b0...b23) or by 3 bytes (denoted Rxa, Rxb, Rxc). This information is uniquely assigned to a given upstream channel. Refer to clauses 5.3.1.3 and 5.3.2.1 for the use of this parameter.

### **Service Channel**

`Service_Channel` is a 3-bit field which defines the channel assigned to the `Service_Channel_Frequency`. It identifies the logical channel (denoted by 'c') assigned to the NIU/STB. Refer to clauses 5.3.2.1 and 5.3.3 for the use of this parameter.

### **Backup Service Channel Frequency**

`Backup_Service_Channel_Frequency` is a 32 bit unsigned integer representing the upstream frequency assigned to the backup service channel. The backup service channel is used when entry on the primary service channel fails. The unit of measure is in Hertz. If there is no Backup Service Channel, this parameter shall be equal to the Service Channel Frequency.

### **Backup\_MAC\_Flag\_Set**

`Backup_MAC_Flag_Set` is an 5-bit field representing the first Flag set assigned to the backup service channel. The function of this field is the same as the `MAC_Flag_Set` above but with respect to the backup service channel. If there is no Backup Service Channel, this parameter shall be equal to the MAC Flag Set.

### **Backup\_Service\_Channel**

`Backup_Service_Channel` is a 3-bit field which defines the channel assigned to the Backup `Service_Channel_Frequency`. The function of this field is the same as the `Service_Channel` above but with respect to the backup channel. If there is no Backup Service Channel, this parameter shall be equal to the Service Channel.

### **Service\_Channel\_Frame\_Length [reserved]**

Unused in this version.

### **Service Channel Last Slot**

`Service_Channel_Last_Slot` is a 16-bit unsigned integer representing the largest slot value of the NIUs' upstream slot position counter (as defined in clause 5.4.4).

Only 13 lowest significant bits shall be considered. 3 MSB are reserved for future use.

Informative note: Since the value of `Service_Channel_Last_Slot` equals  $((N+1) \times 3 \times m) - 1$ , where "N" is the maximum value of the upstream slot position register (M10-M1), and "m" is a constant dependent upon the upstream bit rate, (see clause 5.4.4), one may use it to calculate the fixed number N. The NIU is capable of deriving the `Last_Slot_number` for each channel from N and the upstream bit rate of the respective channel.

### **Maximum Power Level**

`MAX_Power_Level` is a 8-bit unsigned integer representing the maximum power the NIU shall be allowed to use to transmit upstream. The unit of measure is in dB $\mu$ V (RMS) on 75  $\Omega$ .

**Minimum Power Level**

`MIN_Power_Level` is an 8-bit unsigned integer representing the minimum power the NIU shall be allowed to use to transmit upstream. The unit of measure is in dB $\mu$ V (RMS) on 75  $\Omega$ .

**Upstream Transmission Rate**

`Upstream_Transmission_Rate` is a 3-bit enumerated type that indicates the upstream transmission bit rate.

```
enum Upstream_Transmission_Rate {Upstream_256K, Upstream_1,544M, Upstream_3,088M,
Upstream_6,176M, reserved 4...7};
```

**MIN\_Backoff\_Exponent**

`MIN_Backoff_Exponent` is an 8-bit unsigned integer representing the minimum value of the backoff exponent counter. Only the 5 least significant bits are valid, the 3 most significant bits are reserved for future use.

**MAX\_Backoff\_Exponent**

`MAX_Backoff_Exponent` is an 8-bit unsigned integer representing the maximum value of the backoff exponent counter. Only the 5 least significant bits are valid, the 3 most significant bits are reserved for future use.

**Idle\_Interval**

`Idle_Interval` is a 16-bit unsigned integer representing the predefined interval for the Idle Messages. Valid intervals shall be between 60 and 600, where the unit of the measure is in seconds. In addition, the value of zero indicates that no Idle messages shall be sent.

**Absolute\_Time\_Offset**

`Absolute_Time_Offset` is a 16-bit signed integer used to set the default `Absolute_Time_Offset` (defined in clause 5.3.1.3) when first signing on. The unit of measure is 100 ns.

**Frequency Ranging Step**

Used only for LMDS (EN 301 199 [18]).

**Number\_of\_Timeouts**

`Number_of_Timeouts` is a 8-bit unsigned integer which identifies the number of timeout codes and values included in the message.

**Code**

`Code` is a 4-bit unsigned integer which identifies the timeout or group of timeouts (according to Table 21, Table 22 and Table 51) for which the following value is given.

**Value**

`Value` is a 4-bit unsigned integer which gives the value for the timeout or group of timeouts identified by the preceding code. The timeout can be derived from Table 21a.

Table 21a

Value	Timeout (ms)
0	Infinite (disabled)
1	9
2	30
3	60
4	90
5	300
6	600
7	900
8	3000
9	6000
10	9000
11	30000
12	60000
13	Reserved
14	Reserved
15	Reserved

If no values are given in the <MAC> Default Configuration Message, the default values apply.

Table 21: Headend Timeout Values

Code	Transaction(s)	Default Value
0x0	Ranging and power calibration -> Ranging and power calibration response Connect -> Connect response (no frequency change) Release -> Release response Transmission control -> Link management response (no frequency change) Reservation ID assignment -> Reservation ID response Reprovision -> Link management response (no frequency change) Status request -> Status response message Init complete -> Connect response Init. complete -> Link management response	300
0x1	Connect -> Sign on response (only for frequency change) Reprovision -> Sign on response (only for frequency change) Transmission control -> Sign on response (only for frequency change)	3000

The Unit for the timeouts is the millisecond (ms).

These timeouts apply when the mentioned two messages are consecutive.

Table 22: Terminal Timeout Values

Code	Transaction(s)	Default Value
0x2	Default configuration interval(time between two Def. Conf. msg) Sign on request interval	900
0x3	Sign on response -> Ranging and power calibration Sign on response -> Initialization complete Ranging and power calibration response -> Ranging and power calibration Ranging and power calibration response -> Initialization complete Connect response -> Connect confirm Resource Request -> Release Resource Request -> Reservation_ID assignement	90
0x4	Initialization complete -> Connect Resource Request -> Resource Request Denied Resource Request -> Connect Resource Request -> Reprovision Timeout in ERROR state (time to wait before going to "Wait for Provisioning Message" state, see clause A.1)	300

The Unit for the timeouts is the millisecond (ms).  
These timeouts apply when the mentioned two messages are consecutive.

### INA\_Capabilities

INA\_Capabilities is a 32-bit field that indicates the capabilities of the INA. It has the following subfields:

Encapsulation is an 8-bit field that indicates the type(s) of encapsulation supported by the INA: {DIRECT\_IP, Ethernet\_MAC\_Bridging, PPP, reserved 3...7}. Bit 0 is the lsb and corresponds to bit 24 of the INA\_Capabilities field.

US\_Bitrate is an 8-bit field that indicates the upstream bitrate(s) supported by the INA: {256 kbit/s, 1,544 Mbit/s, 3,088 Mbit/s, 6,176 Mbit/s, reserved 4...7}. Bit 0 is the lsb and corresponds to bit 16 of the INA\_Capabilities field.

DS\_OOB\_Bitrate is a 4-bit field that indicates the downstream OOB bitrate(s) supported by the INA: {1,544 Mbit/s, 3,088 Mbit/s, reserved 2...3}. Bit 0 is the lsb and corresponds to bit 12 of the INA\_Capabilities field.

Capabilities\_extended\_included: 1-bit field. if true, the message includes the INA\_capabilities\_extended field.

Reserved: Reserved for future use

DS\_Header\_Suppression is a 1-bit field that indicates if the INA supports header suppression in downstream direction.

US\_Header\_Suppression is a 1-bit field that indicates if the INA supports header suppression in upstream direction.

Piggy\_Back\_Capable is a 1-bit field that indicates if the INA is able to process Piggy Back requests and assignments.

Resource\_Request\_Capable is a 1-bit field that indicates if the INA is able to process <MAC> Resource Request Messages.

Fragmented\_MAC\_Messages is a 1-bit field that indicates that the INA is able to support MAC messages having the compound MAC\_Information\_Elements field of a single up to 512 bytes in size. This flag is also for backwards compatibility with INAs not supporting MAC message fragmentation and re-assembly. By not setting this bit, the INA indicates that it does not support fragmented MAC messages at all, and will not understand or utilize the Fragment\_No\_MAC\_Address and Fragment\_MAC\_Address\_Included MAC message syntax types.

Security\_Supported is a 1-bit field that indicates that the INA is able to support the security extensions specified in this protocol.

Minislots\_for\_Reservation is an 1-bit field that indicates that the INA is capable of utilizing minislots.

Reserved\_for\_DAVIC: Reserved for compatibility with DAVIC.

IB\_Signalling is an 1-bit field that indicates that the INA is capable of utilizing IB signalling.

OOB\_Signalling is an 1-bit field that indicates that the INA is capable of utilizing OOB signalling.

### INA\_Capabilities\_Extended

INA\_Capabilities\_Extended is a 32-bit field that indicates further capabilities of the INA. It has the following subfields:

Reserved: Reserved for future use

Session\_binding is a 1-bit boolean field, indicating if the INA supports session binding .

16QAM\_Minislots is a 1-bit field that indicates if the INA supports 16QAM minislots.

16QAM is a 1-bit field that indicates if the INA supports 16QAM modulation.

## 5.5.4 Sign On and Calibration

The NIU shall Sign On via the Sign-On Procedure. The signalling flow for Sign-On is described below.

- The NIU shall tune to the downstream Provisioning channel and the upstream service channel with the information provided in the Initialization and Provisioning sequence.
- The NIU shall await the **<MAC> Sign-On Request Message** from the INA Entity.
- Upon receiving the **<MAC> Sign-On Request Message**, the NIU shall respond with the **<MAC> Sign-On Response Message**. The Sign-On Response Message shall be transmitted on a Ranging Slot. The NIU/STB shall either use settings of the last successful Sign-on procedure if it is enabled by the INA or the Min\_Power\_Level contained in the **<MAC> Default Configuration Message**.
- The INA, upon receiving the Sign-On Response Message shall validate the NIU, either sending **<MAC> Initialization Complete Message** or the **<MAC> Ranging and Power Calibration Message**.
- The NIU shall respond to the **<MAC> Ranging and Power Calibration Message** with the **<MAC> Ranging and Power Calibration Response Message**. The **<MAC> Ranging and Power Calibration Response Message** shall be transmitted on a Ranging Slot (which can either be in the ranging region (b0 = 1) or reserved region (if a ranging slot number is given in the message). The calibration sequence is not always necessary.
- The INA shall send the **<MAC> Initialization Complete Message** when the NIU is calibrated. The NIU is assumed to be calibrated if the message arrives within a window of  $\pm 0,75$  symbols (upstream rate) and a power within a window of  $\pm 1,5$  dB from their optimal value.

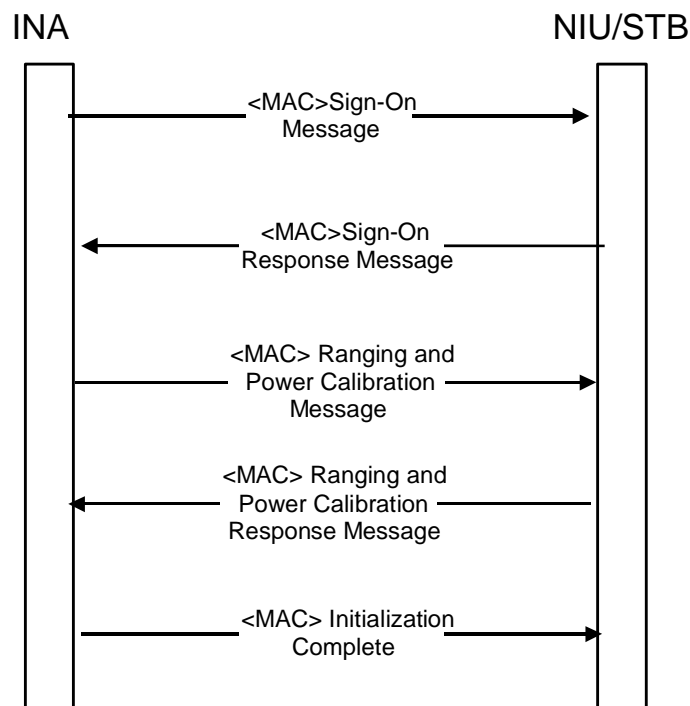

**Figure 35: Ranging and Calibration Signalling**

A more detailed description of the ranging and calibration process, including state diagrams and time outs, is given in clause A.1.

### 5.5.4.1 <MAC> Sign-On Request Message (Broadcast Downstream)

The **<MAC> Sign-On Request** message is issued periodically by the INA to allow a NIU to indicate its presence in the network. The format of this subcommand is shown in Table 23.

Table 23: Sign-On Request Message Structure

Sign-On_Request_Message(){	Bits	Bytes	Bit Number/Description
<b>Sign-On_Control_Field</b>		<b>1</b>	
Reserved	6		7...2
Need_Calibration	1		1: {0 = enable rapid sign-on, 1 = disable rapid sign-on}
Address_Filter_Params_Included	1		0: {no, yes}
<b>Response_Collection_Time_Window</b>	<b>16</b>	<b>2</b>	
<i>if (Sign-On_Control_Field &amp;=</i> <i>Address_Filter_Params_Included {</i>			
<b>Address_Position_Mask</b>	<b>(8)</b>	<b>(1)</b>	
<b>Address_Comparison_Value</b>	<b>(8)</b>	<b>(1)</b>	
}			
}			

### Sign-On Control Field

`Sign-On_Control_Field` specifies what parameters are included in the SIGN-ON REQUEST:

`Need_Calibration` indicates to the NIU that it has to enter the sign-on process starting with the `Min_Power_Level` and `Absolute_Time_Offset` (and `Frequency_Offset` for LMDS) defined in the <MAC> `Default_Configuration_message`. If the bit is not set, the NIU is allowed to start the sign-on with the values for `Power_Level` and `Time_Offset` (and `Frequency_Offset` for LMDS) that it has used for its last upstream transmission after successful sign-on. This bit is only to be taken into account for sign-on processes that follow the reception of a Transmission Control Message, Reprovision\_Message or Connect\_Message. In all other cases the parameters defined in the <MAC> `Default_Configuration_Message` have to be used independent of the setting of the `Need_Calibration` bit.

`Address_Filter_Params_Included` is a boolean, when set, indicates that the NIU should respond to the SIGN-ON REQUEST only if its address matches the filter requirements specified in the message.

### Response Collection Time Window

`Response_Collection_Time_Window` is a 16-bit unsigned integer that specifies the maximum time for the SIGN-ON RESPONSE message transmission randomization. The unit of measure is the millisecond (ms).

### Address Position Mask

`Address_Position_Mask` is an 8-bit unsigned integer that indicates the bit positions in the NIU MAC address that are used for address filtering comparison. The bit positions are comprised between bit number `Mask` and `Mask+7`. `Mask = 0` corresponds to the 8 LSBs of the address, i.e., it represents the number of bits shifted to the left. The maximum value is 40.

### Address Comparison Value

`Address_Comparison_Value` is an 8-bit unsigned integer that specifies the value that the NIU should use for MAC address comparison.

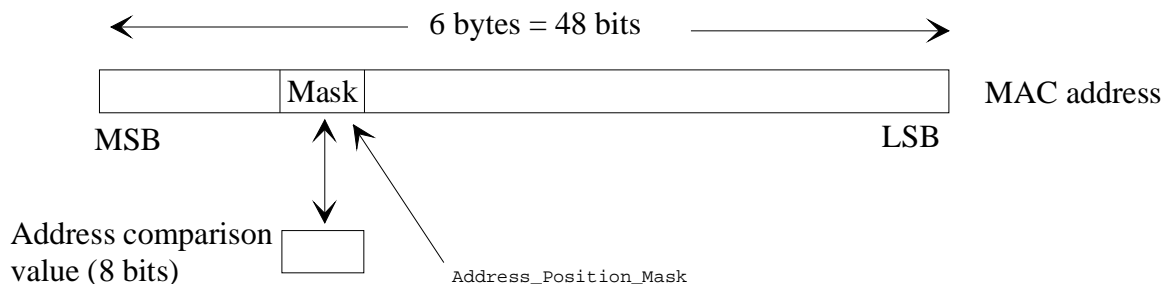

Figure 36: Position of Mask in MAC address

### 5.5.4.2 <MAC> Sign-On Response Message (Upstream Ranging)

The <MAC> Sign-On Response Message is sent by the NIU in response to the <MAC> Sign-On Request Message issued by the INA Entity. The NIU shall wait for a random time less than `Response_Collection_Time_Window` to send this message.

If the sign-on procedure did not start at the `Min_Power_Level` (see clause 5.5.4), when the NIU has not received any response from the INA after `Sign_On_Incr_Pwr_Retry_Count` attempts, it shall retry with the `Min_Power_Level`.

**Table 24: Sign-On response Message structure**

Sign-On_Response_Message(){	Bits	Bytes	Bit Number / Description
<b>NIU/STB_Status</b>		<b>4</b>	
Reserved	29		31...3
Network_Address_Registered	1		2:{no, yes}
Connection_Established	1		1:{no, yes}
Reserved for compatibility	1		0
<b>NIU/STB_Error_Code</b>		<b>2</b>	
Reserved	13		15...3
Connect_Confirm_Timeout	1		2:{no, yes}
First_Connection_Timeout	1		1:{no, yes}
Range_Response_Timeout	1		0:{no, yes}
<b>NIU/STB_Retry_Count</b>	<b>8</b>	<b>1</b>	
<b>NIU/STB_Capabilities</b>		<b>4</b>	
Encapsulation	8		31...24
US_Bitrate	8		23...16
DS_OOB_Bitrate	4		15...12
Capabilities_extended_included	1		11: {no, yes}
Reserved	1		10: shall be zero
DS_Header_Suppression	1		9: {no, yes}
US_Header_Suppression	1		8: {no, yes}
Piggy_Back_Capable	1		7: {no, yes}
Resource_Request_Capable	1		6: {no, yes}
Fragmented_MAC_Messages	1		5:{no, yes}
Security_Supported	1		4:{no, yes}
Minislots_for_Reservation	1		3: {no, yes}
Reserved_for_DAVIC	1		2: shall be zero
IB_Signalling	1		1: {no, yes}
OOB_Signalling	1		0: {no, yes}
<i>if (NIU_capabilities &amp;= capabilities_extended_included) {</i>			
<b>NIU_capabilities_extended</b>		<b>4</b>	
Reserved	30		31...4: must be 0
Session_binding	1		3:{no,yes}
Extended_Reprovision	1		2: {no, yes}
16QAM_minislots	1		1: {no, yes}
16QAM	1		0: {no, yes}
<i>}</i>			
<i>}</i>			

#### NIU/STB\_Status

NIU/STB\_Status is a 32-bit field that indicates the current state of the NIU/STB. It has the following subfields:

`Network_Address_Registered` indicates that the Network Interface Module has registered its NSAP Address with the Application Module. The NSAP Address is not currently used but remains reserved for this purpose.

`Connection_Established` indicates that the Network Interface Module has been assigned Connection parameters.



**NIU/STB\_Error\_Code**

NIU/STB\_Error\_Code is an 16-bit field that indicates the error condition within the NIU/STB. It has the following subfields:

Connect_Confirm_Timeout	(set to 1 for transition SCE:E4 or DCE:E8, see clause A.2)
First_Connection_Timeout	(set to 1 for transition DCE:E2, see clause A.2)
Range_Response_Timeout	(set to 1 for transition RC:E13, see clause A.1)

In case of a timeout in the current signalling, the corresponding subfield is set to one, see clause A.1.

**NIU/STB\_Retry\_Count**

NIU/STB\_Retry\_Count is a 8-bit unsigned integer that indicates the number of transmissions of the <MAC> Sign-On Response. This field is always included in the response to the <MAC> Sign-On Request. This field shall be initialized to zero whenever a Sign-On procedure is started, and this field shall be incremented by one each time the message is transmitted until the Sign-On procedure completes or the value reaches its maximum value (255). In the case that this field reaches its maximum value, it shall remain at the maximum value for the remainder of the current Sign-On procedure.

**NIU/STB\_Capabilities**

NIU/STB\_Capabilities is a 32-bit field that indicates the capabilities of the NIU/STB. It has the following subfields:

Encapsulation is an 8-bit field that indicates the type(s) of encapsulation supported by the NIU/STB: {DIRECT\_IP, Ethernet\_MAC\_Bridging, PPP, reserved 3...7}. Bit 0 is the lsb and corresponds to bit 24 of the NIU/STB\_Capabilities field.

US\_Bitrate is an 8-bit field that indicates the upstream bitrate(s) supported by the NIU/STB: {256 kbit/s, 1,544 Mbit/s, 3,088 Mbit/s, 6,176 Mbit/s, reserved 4...7}. Bit 0 is the lsb and corresponds to bit 16 of the NIU/STB\_Capabilities field.

DS\_OOB\_Bitrate is a 4-bit field that indicates the downstream OOB bitrate(s) supported by the NIU/STB: {1,544 Mbit/s, 3,088 Mbit/s, reserved 2...3}. Bit 0 is the lsb and corresponds to bit 12 of the NIU/STB\_Capabilities field.

Capabilities\_extended\_included: 1-bit field. if set to true, the message includes the NIU\_capabilities\_extended\_field.

Reserved: Reserved for future use.

DS\_Header\_Suppression is a 1-bit field that indicates if the NIU supports header suppression in downstream direction.

US\_Header\_Suppression is a 1-bit field that indicates if the NIU supports header suppression in upstream direction.

Piggy\_Back\_Capable is a 1-bit field that indicates if the NIU is able to append Piggy Back requests onto a PDU ATM cell.

Resource\_Request\_Capable is a 1-bit field that indicates if the NIU is able to send <MAC> Resource Request Messages.

Fragmented\_MAC\_Messages is a 1-bit field that indicates that the NIU/STB is able to support MAC messages having the compound MAC\_Information\_Elements field of a single up to 512 bytes in size. This flag is also for backwards compatibility with NIU/STBs not supporting MAC message fragmentation and re-assembly. By not setting this bit, the NIU/STB indicates that it does not support fragmented MAC messages at all, and will not understand or utilize the Fragment\_No\_MAC\_Address and Fragment\_MAC\_Address\_Included MAC message syntax types.

Security\_Supported is a 1-bit field that indicates that the NIU/STB is able to support the security extensions specified in this protocol.

Minislots\_for\_Reservation is a 1-bit field that indicates that the NIU/STB is capable of utilizing minislots.

Reserved\_for\_DAVIC: Reserved for compatibility with DAVIC.

IB\_Signalling is an 1-bit field that indicates that the NIU/STB is capable of utilizing IB signalling.

OOB\_Signalling is an 1-bit field that indicates that the NIU/STB is capable of utilizing OOB signalling.

### NIU/STB\_Capabilities\_Extended

NIU/STB\_Capabilities\_Extended is a 32-bit field that indicates the capabilities of the NIU/STB. It has the following subfields:

Reserved: Reserved for future use.

Session\_binding is a 1-bit field that indicates if the NIU supports session binding.

Extended\_Reprovision is a 1-bit field that indicates if the NIU supports extended reprovision.

16QAM\_Minislots is a 1-bit field that indicates if the NIU supports 16QAM minislots.

16QAM is a 1-bit field that indicates if the NIU supports 16QAM modulation.

### 5.5.4.3 <MAC> Ranging and Power Calibration Message (Singlecast Downstream)

The <MAC> RANGING AND POWER CALIBRATION MESSAGE is sent by the INA to the NIU to adjust the power level or time offset the NIU is using for upstream transmission. The format of this message is shown in the following Table. Minislots are not used for ranging.

**Table 25: Ranging and Power Calibration Message structure**

<b>Ranging_and_Power_Calibration_Message(){</b>	<b>Bits</b>	<b>Bytes</b>	<b>Bit Number / Description</b>
<b>Range_Power_Control_Field</b>		<b>1</b>	
Reserved	4		7-4: shall be 0.
Equalizer_coefficients_included	1		3: {no, yes}
Ranging_Slot_Included	1		2: {no, yes}
Time_Adjustment_Included	1		1: {no, yes}
Power_Adjustment_Included	1		0: {no, yes}
<i>if (Range_Power_Control_Field &amp;= Time_Adjustment_Included) {</i>			
<b>Time_Offset_Value</b>	<b>(16)</b>	<b>(2)</b>	
<i>}</i>			
<i>if (Range_Power_Control_Field &amp;= Power_Adjustment_Included) {</i>			
<b>Power_Control_Setting</b>	<b>(8)</b>	<b>(1)</b>	
<i>}</i>			
<i>if (Range_Power_Control_Field &amp;= Ranging_Slot_Included) {</i>			
<b>Ranging_Slot_Number</b>	<b>(16)</b>	<b>(2)</b>	
<i>}</i>			
<i>if (Range_Power_Control_Field &amp;= Equalizer_coefficients_included) {</i>			
<b>Equalizer_coefficients</b>	<b>(256)</b>	<b>(32)</b>	
<i>}</i>			
<i>}</i>			

#### Range and Power Control Field

Range\_Power\_Control\_Field specifies which Range and Power Control Parameters are included in the message.

#### Equalizer coefficients included

Equalizer\_coefficients\_included indicates if the message include a new set of coefficients for the NIU pre equalizer.

### Time Adjustment Included

`time_adjustment_included` is a boolean when set, indicates that a relative Time Offset Value is included that the NIU should use to adjust its upstream slot transmit position.

### Power Adjust Included

`power_adjust_included` is a boolean when set, indicates that a relative Power Control Setting is included in the message

### Ranging Slot Included

`Ranging_Slot_Included` is a boolean when set, indicates the calibration slot available. When this bit equals 1, the NIU shall send its response on the slot number given by **Ranging Slot Number**. When this bit equals 0, the NIU shall respond on a ranging slot as mentioned in clause A.1.

### Time Offset Value

`Time_Offset_Value` is a 16-bit short integer representing a relative offset of the upstream transmission timing. A negative value indicates an adjustment forward in time (later). A positive value indicates an adjustment back in time (earlier). The unit of measure is 100 ns (The NIU will adjust approximately its time offset to the closest value indicated by the `Time_Offset_Value` parameter, which implies that no extra clock is needed to adjust to the correct offset).

### Power Control Setting

`Power_Control_Setting` is an 8-bit signed integer to be used to set the new power level of the NIU. (A positive value represents an increase of the output power level).

$\text{New output\_power\_level} = \text{current output\_power\_level} + \text{power\_control\_setting} \times 0,5 \text{ dB.}$

### Ranging Slot Number

`Ranging_Slot_Number` is a 16-bit unsigned integer that represents the reserved access Slot Number assigned for Ranging the NIU. It shall be assigned by the INA in the reservation area. The INA shall assure that an unassigned slot precedes and follows the ranging slot.

Only 13 lowest significant bits shall be considered. 3 MSB are reserved for future used.

### Equalizer coefficients

`Equalizer_coefficients` field is a 32 byte field that lists the new coefficients for the NIU pre equalizer. The taps coefficient real and imaginary parts will consist of 16 bit, coded in fractional two's complement notation. The NIU will convolve these coefficients with the current coefficients. The coding order will be: tap0 [real, imag], tap1[real, imag] and so on.

#### 5.5.4.4 <MAC> Ranging and Power Calibration Response Message (Upstream Ranging or reserved)

The <MAC> RANGING AND POWER CALIBRATION RESPONSE Message is sent by the NIU to the INA in response to the <MAC> RANGING AND POWER CALIBRATION MESSAGE. The format of the message is shown in the following Table.

**Table 26: Ranging and Power Calibration Response Message Structure**

Ranging_Power_Response_Message(){	Bits	Bytes	Bit Number/ Description
<b>Power_Control_Setting</b>	<b>8</b>	<b>1</b>	
}			

## Power Control Setting

`Power_Control_Setting` is an 8-bit unsigned integer representing the actual power used by the NIU for upstream transmission. The unit of measure is 0,5 dB $\mu$ V.

### 5.5.4.5 <MAC> Initialization Complete Message (Singlecast Downstream)

The <> INITIALIZATION COMPLETE Message is sent by the INA to the /STB to indicate the end of the Sign-On and Provisioning procedure. The STB/ shall re-enter the initialization process after receiving a non-zero `Completion_Status_Field` value. The <MAC> Transmission Control Message can be used to stop the NIU from sending upstream messages.

Initialization_Complete_Message(){	Bits	Bytes	Bit Number/Description
<b>Completion_Status_Field</b>		<b>1</b>	
Reserved	4		7...4
Invalid_STB/	1		3:{no, yes}
Timing_Ranging_Error	1		2:{no, yes}
Power_Ranging_Error	1		1:{no, yes}
Other_Error	1		0:{no, yes}
}			

## Completion\_Status\_Field

`Completion_Status_Field` is an 8-bit field that indicates errors in the initialization phase. It has the following subfields:

`Invalid_STB/` is a boolean that (when set to 1) indicates that the STB/ is invalid.

`Timing_Ranging_Error` is a boolean that (when set to 1) indicates that the ranging has not succeeded.

`Power_Ranging_Error` is a boolean that (when set to 1) indicates that the power ranging has not succeeded.

`Other_Error` is a boolean that (when set to 1) indicates an error with unspecified type.

## 5.5.5 Connection Establishment

Two cases shall be considered:

- 1) Establishment of the first (initial) connection;
- 2) Establishment of additional connections.

### 5.5.5.1 Establishment of the First (Initial) Connection

After Initialization, Provisioning and Sign On Procedures are complete, the INA shall assign an upstream and downstream connection to the NIU. This connection can be assigned on any of the upstream channels, according to the NIU/INA capabilities:

NIUs that support 16QAM modulation can be assigned upstream channels that use either QPSK or 16QAM modulation. NIUs that support only QPSK modulation will be assigned any of the QPSK upstream channels.

The INA shall assign the connection by sending the <MAC> **Connect Message** to the NIU. This message shall contain the upstream connection parameters, the downstream frequency on which the connection is to reside, and the channel modulation. From this point, the NIU will use the modulation that is indicated by the channel (16QAM/QPSK).

The NIU, upon receiving the <MAC> **Connect Message** shall tune to the required upstream and downstream frequencies and send the <MAC> **Connect Response Message** confirming receipt of the message. However, if the US and/or the DS frequency contained in the <MAC> Connect Message is different than the current US and/or DS frequency, the NIU/STB shall tune to the new frequency(ies) and enter the Sign-On procedure as defined in clause 5.5.4, the Connection\_Established flag being set and the NIU/STB retry count reset. The NIU/STB shall send the <MAC> Connect Response Message after the <MAC> Initialization Complete Message.

Upon receipt of the <MAC> **Connect Response Message**, the INA shall confirm the new connection by sending the <MAC> **Connect Confirm Message**.

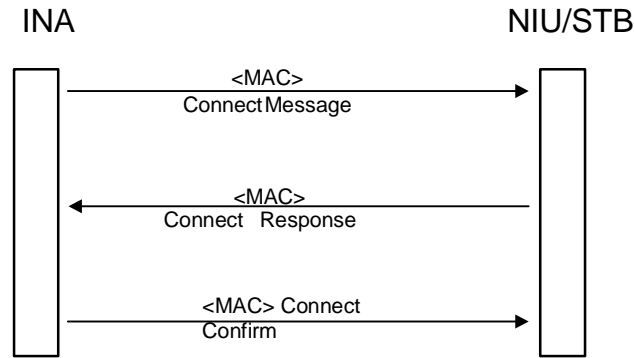

**Figure 37: Connection Signalling for the Initial Connection**

A more detailed description of the connection establishment process, including state diagrams and time outs, is given in clause A.2.

## &lt;MAC&gt; Connect Message (Singlecast Downstream)

Table 27: Connect Message Structure

Connect_Message (){	Bits	Bytes	Bit Number/ Description
<b>Connection_ID</b>	32	4	
<b>Session_Number</b>	32	4	
<b>Connection_Control_Field_Aux</b>		1	
Connection_control_field2_included	1		7: {no, yes}
IPv6_add	1		6: {no, yes}
Priority_Included	1		5: {no, yes}
Flowspec_DS_Included	1		4: {no, yes}
Session_Binding_US_Included	1		3: {no, yes}
Session_Binding_DS_Included	1		2: {no, yes}
Encapsulation_Included	1		1: {no, yes}
DS_Multiprotocol_CBD_Included	1		0: {no, yes}
<b>Resource_Number</b>	8	1	
<b>Connection_Control_Field</b>		1	
DS_ATM_CBD_Included	1		7: {no, yes}
DS_MPEG_CBD_Included	1		6: {no, yes}
US_ATM_CBD_Included	1		5: {no, yes}
Upstream_Channel_Number	3		4...2
Slot_List_Included	1		1: {no, yes}
Cyclic_Assignment	1		0: {no, yes}
<b>Frame_Length</b>	16	2	
<b>Maximum_Contention_Access_Message_Length</b>	8	1	
<b>Maximum_Reservation_Access_Message_Length</b>	8	1	
if (Connection_Control_Field &= DS_ATM_CBD_Included) {			
<b>Downstream_ATM_CBD()</b>	(64)	(8)	
}			
if (Connection_Control_Field &= DS_MPEG_CBD_Included) {			
<b>Downstream_MPEG_CBD()</b>	(48)	(6)	
}			
if (Connection_Control_Field &= US_ATM_CBD_Included) {			
<b>Upstream_ATM_CBD()</b>	(64)	(8)	
}			
if (Connection_Control_Field &=			
Slot_List_Included) {			
<b>Number_Slots_Defined</b>	(8)	(1)	
for (i=0; i<Number_Slots_Defined; i++){			
<b>Slot_Number</b>	(16)	(2)	
}			
}			
if (MAC_Control_Params == Cyclic_Assignment){			Fixed RateAccess
<b>Fixedrate_Start</b>	(16)	(2)	
<b>Fixedrate_Dist</b>	(16)	(2)	
<b>Fixedrate_End</b>	(16)	(2)	
}			
if (Connection_Control_Field_Aux &=			
DS_Multiprotocol_CBD_Included) {			
<b>Downstream_Multiprotocol_CBD()</b>	(48)	(6)	
}			
if (Connection_Control_Field_Aux &= Encapsulation_Included) {			
<b>Encapsulation</b>	(8)	(1)	
}			
if (Connection_Control_Field_Aux &= priority_Included) {			
<b>Priority</b>	(8)	(1)	
}			
if (Connection_Control_Field_Aux &= flowspec_DS_Included) {			
<b>Max_packet_size</b>	(16)	(2)	Bytes
<b>Average_bitrate</b>	(16)	(2)	Bytes/s
<b>Jitter</b>	(8)	(1)	ms
}			
if (Connection_Control_Field_Aux &=			

Connect_Message (){	Bits	Bytes	Bit Number/ Description
<i>upstream_session_binding_Included) &amp;&amp; (Connection_Control_Field_Aux != IPv6_add) {</i>			
<b>US_session_binding_control</b>	(32)	(4)	
<b>NIU_client_source_IP_add</b>	(32)	(4)	
<b>NIU_client_destination_IP_add</b>	(32)	(4)	
<b>NIU_client_source_port</b>	(16)	(2)	
<b>NIU_client_destination_port</b>	(16)	(2)	
<b>Upstream_transport_protocol</b>	(8)	(1)	
<b>NIU_client_source_MAC_add</b>	(48)	(6)	
<b>NIU_client_destination_MAC_add</b>	(48)	(6)	
<b>Upstream_interent_protocol</b>	(16)	(2)	
<b>Upstream_session_Id</b>	(32)	(4)	
}			
<i>if (Connection_control_aux_Field &amp;= downstream_session_binding_Included) &amp;&amp; (Connection_Control_Field_Aux != IPv6_add) {</i>			
<b>DS_session_binding_control</b>	(32)	(4)	
<b>INA_client_source_IP_add</b>	(32)	(4)	
<b>INA_client_destination_IP_add</b>	(32)	(4)	
<b>INA_client_source_port</b>	(16)	(2)	
<b>INA_client_destination_port</b>	(16)	(2)	
<b>Downstream_transport_protocol</b>	(8)	(1)	
<b>INA_client_source_MAC_add</b>	(48)	(6)	
<b>INA_client_destination_MAC_add</b>	(48)	(6)	
<b>Dowstream_interent_protocol</b>	(16)	(2)	
<b>Dowstream_session_Id</b>	(32)	(4)	
}			
<i>if (Connection_Control_Field_Aux &amp;=aux_control_field2_included) {</i>			
<b>Connection_control_field2</b>		(1)	
Reserved	(7)		7...1: shall be 0
Upstream_modulation_included	(1)		0: {no, yes}
<i>if (Connection_Control_Field2 &amp;= Upstream_modulation_included) {</i>			
<b>Upstream_Modulation</b>	(8)	(1)	
}			
}			

### Connection ID

Connection\_ID is a 32-bit unsigned integer representing a connection Identifier for the NIU Dynamic Connection.

### Session Number

Session\_Number is a 32-bit unsigned integer representing the Session that the connection parameters are associated. This parameter is not used by the present document.

### Connection Control Field\_Aux

Connection\_control\_field2\_included: a 1-bit field. if true, the message includes a Connection\_control\_field2 field.

IPv6\_add: if set to 1, IP addresses at the session binding blocks are IPv6 compatible.

Priority\_included: if set to 1, the message includes a priority field.

Flowspec\_DS\_included: if set to 1, the message includes a downstream flow spec.

Session\_binding\_US\_Included: if set to 1, the message includes a session binding description for the upstream.

Session\_binding\_DS\_included: if set to 1, the message includes a session binding description for the downstream.

Encapsulation\_Included is a boolean that indicates that the type of encapsulation is included in the message.

DS\_Multiprotocol\_CBD\_Included is a boolean that indicates that the Downstream Multiprotocol Descriptor is included in the message.

#### *Resource Number*

Resource\_Number is a 8-bit unsigned integer providing a unique number to the resource defined in the message. If the Connect Message is the result of a Resource Request by the NIU, it shall be equal to the Resource\_Request\_ID of the Resource Request, otherwise it shall be 0.

#### *Connection Control Field*

DS\_ATM\_CBD\_Included is a boolean that indicates that the Downstream Descriptor is included in the message.

DS\_MPEG\_CBD\_Included is a boolean that indicates that the Downstream Descriptor is included in the message.

US\_ATM\_CBD\_Included is a boolean that indicates that the Upstream Descriptor is included in the message.

Upstream\_Channel\_Number is a 3-bit unsigned integer which identifies the logical channel (denoted by 'c') assigned to the NIU/STB. Refer to clause 5.3.2.1 for the use of this parameter.

Slot\_List\_Included is a boolean that indicates that the Slot List is included in the message. Having Cyclic Assignments and Slot List Assignments for the same Connect\_ID at the same time is not allowed.

Cyclic\_Assignment is a boolean that indicates Cyclic Assignment. Having Cyclic Assignments and Slot List Assignments for the same Connect\_ID at the same time is not allowed.

The connection type can be deduced from the presence or the absence of the Connection Control Fields relative to the CBDs. The following table summarizes the valid combinations.

<b>DS_ATM_CBD</b>	<b>DS_MPEG_CBD</b>	<b>Connection Type</b>
YES	NO	OOB
NO	YES	DVB Multiprotocol Encapsulation over MPEG [6]
YES	YES	Reserved for ATM over DVB Data piping over MPEG [14]

All other combinations will not be used by the INA. If so, the message shall be ignored by the NIU/STB (no <MAC>Connect Response Message shall be sent).

#### *Frame Length*

Frame\_length - This 16-bit unsigned number represents the number of successive slots in the fixed rate access region associated with each fixed rate slot assignment. In the slot\_list method of allocating slots it represents the number of successive slots associated with each element in the list. In the cyclic method of allocating slots it represents the number of successive slots associated with the Fixedrate\_Start\_slot and those which are multiples of Fixedrate\_Distance from the Fixedrate\_Start\_slot within the Fixed rate access region.

#### *Maximum Contention Access Message Length*

Maximum\_contention\_access\_message\_length is an 8-bit number representing the maximum length of a message in upstream packets that may be transmitted using contention access. Any message greater than this should use reservation access.

#### *Maximum Reservation Access Message Length*

Maximum\_reservation\_access\_message\_length is an 8-bit number representing the maximum length of a message in upstream packets that may be transmitted using a single reservation access. Any message greater than this shall be transmitted by making multiple reservation requests.



*Downstream ATM Connection Block Descriptor***Table 28: Downstream\_ATM\_CBD substructure**

<b>Downstream_ATM_CBD(){</b>	<b>Bits</b>	<b>Bytes</b>	<b>Bit Number/Description</b>
Downstream_Frequency	32	4	
Downstream_VPI	8	1	
Downstream_VCI	16	2	
Downstream_Type	8	1	
}			

Downstream\_Frequency is a 32-bit unsigned integer representing the Frequency where the connection resides. The unit of measure is in Hertz.

Downstream\_VPI is an 8-bit unsigned integer representing the ATM Virtual Path Identifier that is used for downstream transmission over the Dynamic Connection.

Downstream\_VCI is a 16-bit unsigned integer representing the ATM Virtual Channel Identifier that is used for downstream transmission over the Dynamic Connection.

Downstream\_Type is an 8-bit enumerated type indicating the modulation format for the down stream connection. {QAM\_MPEG, QPSK\_1,544, QPSK\_3,088, 3...255 reserved}.

*Downstream MPEG Connection Block Descriptor***Table 29: Downstream\_MPEG\_CBD substructure**

<b>Downstream_MPEG_CBD(){</b>	<b>Bits</b>	<b>Bytes</b>	<b>Bit Number / Description</b>
Downstream_Frequency	32	4	
Program_Number	16	2	
}			

Downstream\_Frequency is a 32-bit unsigned integer representing the Frequency where the connection resides. The unit of measure is in Hertz.

Program\_Number is a 16-bit unsigned integer uniquely referencing the downstream virtual connection assignment (PID of the MPEG-2 header, **not** equal to the program number defined by MPEG-2!). Only the 13 least significant bits are valid, the three most significant bits are reserved for future use.

*Upstream ATM Connection Block Descriptor***Table 30: Upstream\_ATM\_CBD substructure**

<b>Upstream_ATM_CBD(){</b>	<b>Bits</b>	<b>Bytes</b>	<b>Bit Number / Description</b>
<b>Upstream_Frequency</b>	<b>32</b>	<b>4</b>	
<b>Upstream_VPI</b>	<b>8</b>	<b>1</b>	
<b>Upstream_VCI</b>	<b>16</b>	<b>2</b>	
MAC_Flag_Set	5	1	7...3
Upstream_Rate	3		2...0
}			

Upstream\_Frequency is a 32-bit unsigned integer representing the channel on assigned to the connection. The unit of measure is in Hertz.

Upstream\_VPI is an 8-bit unsigned integer representing the ATM Virtual Path Identifier that is used for upstream transmission over the Dynamic Connection.

`Upstream_VCI` is a 16-bit unsigned integer representing the ATM Virtual Channel Identifier that is used for upstream transmission over the Dynamic Connection.

`MAC_Flag_Set` is a 5-bit field representing the first Flag set assigned to the logical channel. A downstream channel contains information for each of its associated upstream channel. This information is contained within structures known as MAC Flag Sets represented by either 24 bits (denoted `b0...b23`) or by 3 bytes (denoted `Rxa, Rxb, Rxc`). This information is uniquely assigned to a given upstream channel. Refer to clauses 5.3.1.3 and 5.3.2.1 for the use of this parameter.

`Upstream_Rate` is a 3-bit enumerated type indicating the upstream transmission grade for the upstream connection. { `Upstream_A_AQ, Upstream_B_BQ, Upstream_C_CQ, Upstream_D_DQ, 4...7 reserved` }

#### *Number of Slots Defined*

`Number_Slots_Defined` is an 8-bit unsigned integer that represents the number of slot assignments contained in the message. The unit of measure is slots.

#### *Slot Number*

`Slot_Number` is a 16-bit unsigned integer that represents the Fixed rate based Slot Number assigned to the NIU. Only 13 lowest significant bits shall be considered. 3 MSB are reserved for future use.

#### *Fixed Rate Start*

`Fixedrate_Start` - This 16-bit unsigned number represents the starting slot within the fixed rate access region that is assigned to the NIU. The NIU may use the next `Frame_length` slots of the fixed rate access regions. Only 13 lowest significant bits shall be considered. 3 MSB are reserved for future use.

#### *Fixed Rate Distance*

`Fixedrate_Distance` - This 16-bit unsigned number represents the distance in slots (taking into account all slots of all regions) between additional slots assigned to the NIU. The NIU is assigned all slots that are a multiple of `Fixedrate_Distance` from the `Fixedrate_Start_slot` which do not exceed `Fixedrate_End_slot`. The NIU may use the next `Frame_length` slots of the fixed rate access regions from each of these additional slots.

#### *Fixed Rate End*

`Fixedrate_End` - This 16-bit unsigned number indicates the last slot that may be used for fixed rate access. The slots assigned to the NIU, as determined by using the `Fixedrate_Start_slot`, the `Fixedrate_Distance` and the `Frame_length`, cannot exceed this number. Only 13 lowest significant bits shall be considered. 3 MSB are reserved for future use.

#### *Downstream Multiprotocol Connection Block Descriptor*

**Table 31: Downstream\_Multiprotocol\_CBD substructure**

<b>Downstream_Multiprotocol_CBD(){</b>	<b>Bits</b>	<b>Bytes</b>	<b>Bit Number / Description</b>
<b>MAC_Address</b>	<b>48</b>	<b>6</b>	
<b>}</b>			

`MAC_Address` is a 48-bit MAC address, identifying the only MAC address (for the connection established by this `<MAC> Connect_Message`) (used for example for multicast) to filter on in the DVB Multiprotocol Encapsulation header, according to EN 301 192 [6]. By default (for connections where no `Downstream_Multiprotocol_CBD` is given in the `<MAC> Connect_Message`) the NIU filters on its own MAC address and the Broadcast MAC address `FF:FF:FF:FF:FF:FF`.

`Encapsulation` is an 8-bit field that indicates the type of encapsulation provided: { `Direct_IP, Ethernet_MAC_Bridging, PPP, reserved 3...7` }

`Priority`: 1 byte field. The value of the field defines the priority of the connection. Connections with low priority field value can be reprovisioned in order to accommodate the requirements of connections with high priority field. Priority values will be given according to the following table.

Application	Priority values
Standard data flow applications	0-79
Applications with QoS requirements	80-200
High priority applications	201-255

#### Downstream flow spec:

The downstream flow spec has three parameters:

**Max\_Packet\_size**: the size of the maximum packet (bytes) that will be sent through the connection in the downstream. The packet size includes propriety protocols header, transport protocol (UDP/TCP) header, and the IP header. The packet size does not include the Ethernet header.

**Average\_bitrate**: the avearge bit rate, in bytes/s.

**Jitter**: the total jitter that downstream packets can experience.

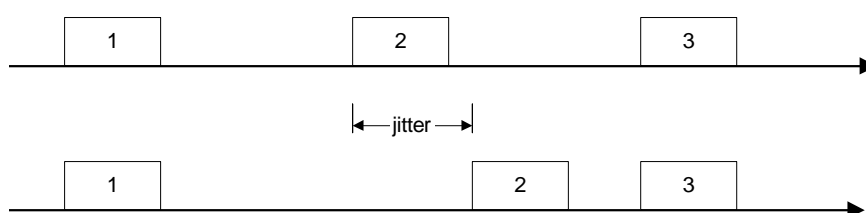

**Figure 38: Downstream Jitter Definition**

#### Session binding information:

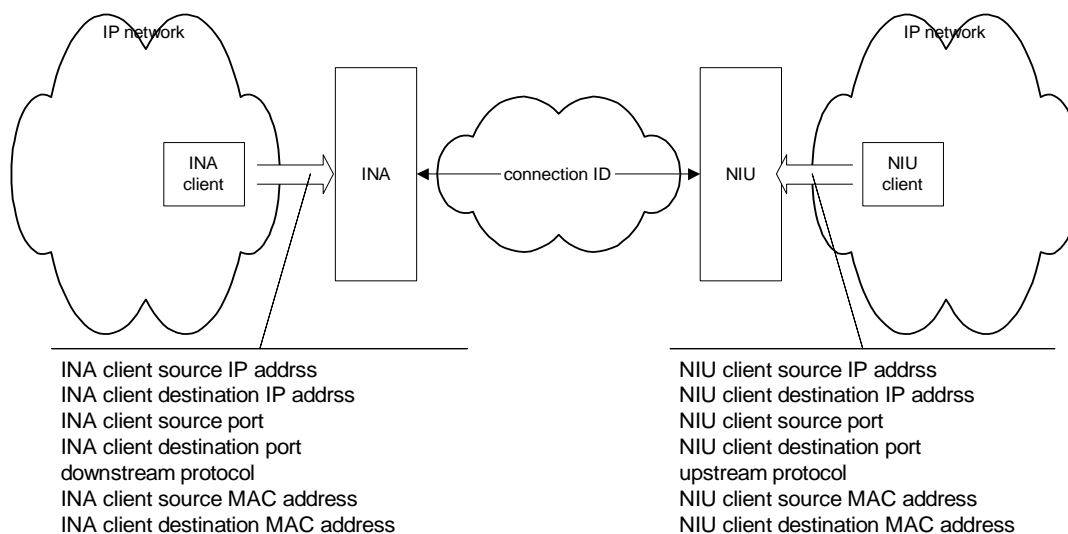

**Figure 39: Session Binding Information**

The upstream and downstream session binding blocks identify clients that are using the connection. The clients are identified by their source and destination, the source and destination ports (if relevant), and the protocol.

In most cases, the downstream and upstream session binding will be identical:

- NIU client source IP address = INA client destination IP address,
- NIU client source port = INA client destination port, and
- necessarily upstream protocol = downstream protocol.

In this case, only the upstream session binding is sent.

The message will contain a DS session binding only if there is a difference in the INA and NIU source destination ports and addresses:

(NIU client source IP address  $\neq$  INA client destination IP address,  
NIU client source port  $\neq$  INA client destination port ).

**US\_session\_binding\_control:** the interpretation of the US session binding block depends on the value of US\_session\_binding\_control field. The field acts as a bit map, indicating the existence of the different session binding parameters. If the bit attached to the session binding parameter, is set to 1, then the parameter exists in the message. If not, the session binding parameter does not exist. In case a bit indicating to a field that is not defined at the moment is set to 1, the NIU MUST treat the field as a 32-bit field long, and MAY ignore it.

The mapping between the current session binding parameters and the US\_session\_binding\_control field is described in Table 2.

US_session_binding_control bit number	US session binding parameter
0	NIU_client_source_IP_add
1	NIU_client_destination_IP_add
2	NIU_client_source_port
3	NIU_client_destination_port
4	Upstream_transport_protocol
5	<b>NIU_client_source_MAC_add</b>
6	<b>NIU_client_destination_MAC_add</b>
7	Upstream_ethernet_protocol
8	Upstream_session_Id
10-31	Reserved (must be set to 0)

NIU\_client\_source\_IP\_add: the IP source address of the NIU client.

NIU\_client\_destination\_IP\_add: the IP destination address of the INA client. 00

NIU\_client\_source\_port: the source port of the INA client.

NIU\_client\_destination\_port: the destination port of the INA client.

Upstream\_transport\_protocol: the transport protocol used by the NIU client (UDP/TCP).

NIU\_client\_source\_MAC\_add: a 48-bit unsigned integer that identifies the Ethernet MAC address of the NIU client.

NIU\_client\_destination\_MAC\_add: a 48-bit unsigned integer that identifies the destination Ethernet MAC address of the NIU client.

Upstream\_ethernet\_protocol: a 16-bit field, defining the internet protocol, as described in the ethernet header.

Upstream\_session\_Id: a 32-bit field, describing the session\_Id, as defined for PPPoE protocol.

**DS\_session\_binding\_control:** the interpretation of the DS session binding block depends on the value of DS\_session\_binding\_control field. The field acts as a bit map, indicating the existence of the different session binding parameters. If the bit attached to the session binding parameter, is set to 1, then the parameter exist. If not, the session binding parameter does not exist. In case a bit indicating to a field that is not defined at the moment is set to 1, the NIU MUST treat the filed as a 32-bit field long, and MAY ignore it.

The mapping between the current session binding parameters and the DS\_session\_binding\_control field is described in Table 2.

DS_session_binding_contr bit number	DS session binding parameter
0	INA_client_source_IP_add
1	INA_client_destination_IP_add
2	INA_client_source_port
3	INA_client_destination_port
4	Downstream_transport_protocol
5	INA_client_source_MAC_add
6	INA_client_destination_MAC_add
7	Downstream_ethernet_protocol
8	Downstream_session_Id
10-31	Reserved (must be set to 0)

INA\_client\_source\_IP\_add: the IP source address of the INA client.

INA\_client\_destination\_IP\_add: the IP destination address of the INA client 00

INA\_client\_source\_port: the source port of the INA client.

INA\_client\_destination\_port: the destination port of the INA client.

Downstream\_transport\_protocol: the transport protocol used by the INA client (UDP/TCP).

INA\_client\_source\_MAC\_add: a 48-bit unsigned integer that identifies the Ethernet MAC address of the INA client.

INA\_client\_destination\_MAC\_add: a 48-bit unsigned integer that identifies the destination Ethernet MAC address of the INA client.

Downstream\_ethernet\_protocol: a 16-bit field, defining the internet protocol, as described in the ethernet header.

Downstream\_session\_Id: a 32-bit field, describing the session\_Id, as defined for PPPoE protocol.

Connection\_control\_field2:

Reserved: 7-bit field, for future use. Shall be set to 0.

Upstream\_modulation\_included: if set to true, the message includes the upstream channel modulation type. If this field is not present the Up\_stream modulation is QPSK.

Upstream\_modulation:

Upstream\_modulation: 8-bits field enumerated type indicating the upstream channel modulation {QPSK, 16QAM, 2...255 reserved}

#### <MAC> Connect Response (Upstream Contention or Reserved)

The <MAC> CONNECT RESPONSE MESSAGE is sent to the INA from the NIU in response to the <MAC> CONNECT MESSAGE. The message shall be transmitted on the upstream frequency specified in the <MAC> CONNECT MESSAGE. If the Upstream frequency is different than the current upstream frequency, then the procedure described in clause 5.5.4 shall be used before the <MAC> Connect Response Message is sent. If the Connect Confirm message does not arrive within the specified time interval, the NIU shall resend the Connect Response message.

**Table 32: Connect response message structure**

Connect_Response(){	Bits	Bytes	Bit Number / Description
Connection_ID	32	4	
}			

Connection ID

Connection\_ID is a 32-bit unsigned integer representing a global connection Identifier for the NIU Dynamic Connection.

### <MAC> Connect Confirm (Singlecast Downstream)

The <MAC> Connect Confirm message is sent from the INA to the NIU.

**Table 33: Connect Confirm message structure**

Connect_Confirm(){	Bits	Bytes	Bit Number / Description
Connection_ID	32	4	
}			

#### Connection ID

Connection\_ID is a 32-bit unsigned integer representing a global connection Identifier for the NIU Dynamic Connection.

### 5.5.5.2 Establishment of Additional Connections

The INA can assign additional connections by using the <MAC> Connect Message described previously. The NIU can request such connections using the <MAC> Resource Request Message. Besides from that, the message sequence is the same as for the initial connection, with the following restrictions:

- For one NIU, the US frequency shall be the same for all connections, and the OOB and IB frequencies shall be the same for all OOB and IB connections respectively.
- If a <MAC>Connect Message is received with new values of US and/or DS frequency, the NIU/STB will ignore the message.
- If needed, the INA will use one of the resource management procedure to modify the US or DS frequency (see clause 5.5.10.2 and Link Management) before sending the additional <MAC>Connect Message.

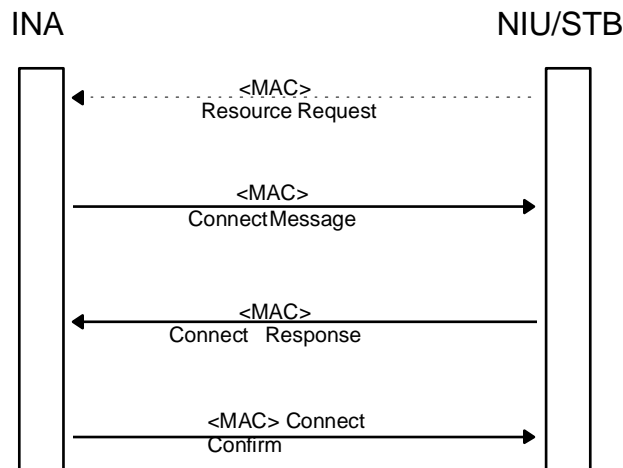

**Figure 40: Connection signalling for additional connections**

A more detailed description of the connection establishment process, including state diagrams and time outs, is given in clauses A.2 and A.5.

### <MAC> Resource Request Message (Upstream)

The NIU may request a new connection, may request to change the parameters of an existing connection and may request to release an existing connection by sending a <MAC> Resource Request Message to the INA. The INA can answer to that request by sending a <MAC> Connect Message, a <MAC> Reservation\_ID Assignment Message/<MAC> Reprovision Message or a <MAC> Release Message, respectively, to the NIU or by sending a <MAC> Resource Request Denied Message to the NIU.

Table 34: Resource Request Message Structure

Resource_Request_Message() {	Bits	Bytes	Bit Number/Description
<b>Resource_Request_ID</b>	<b>8</b>	<b>1</b>	
<b>Connection_ID</b>	<b>32</b>	<b>4</b>	
<b>Field</b>		<b>1</b>	
Aux_control_field_included	1		7: {no, yes}
Admit_flag	1		6: {no, yes}
Priority_included	1		5: {no, yes}
Max_packet_size_included	1		4: {no, yes}
Session_binding_US_IncludedRelease_Requested	1		3: {no, yes}
Reservation_ID_Requested	1		2: {no, yes}
Cyclic_Assignment_Needed	1		1: {no, yes}
<b>Requested_Bandwidth</b>	<b>24</b>	<b>3</b>	<b>The unit is slots/1 200 ms</b>
<b>Maximum_Distance_Between_Slots</b>	<b>16</b>	<b>2</b>	<b>The unit is slots</b>
<b>Encapsulation</b>	<b>8</b>	<b>1</b>	
<i>If (Field &amp;= aux_control_field_Included) {</i>			
<b>Aux_control_field</b>		<b>(1)</b>	
Reserved	(5)		7...2 must be 0
IPv6_add	(1)		2: {no,yes}
Flowspec_DS_included	(1)		1:{no, yes}
Session_binding_DS_included	(1)		0: {no, yes}
<i>}</i>			
<i>If (Field &amp;= priority_Included) {</i>			
<b>Priority</b>	<b>(8)</b>	<b>(1)</b>	
<i>}</i>			
<i>If (Field &amp;= max_packet_size_Included) {</i>			
<b>Frame_length</b>	<b>(16)</b>	<b>(2)</b>	Slots
<i>}</i>			
<i>If (aux_control_Field &amp;= Flowspec_DS_included) {</i>			
<b>Max_packet_size</b>	<b>(16)</b>	<b>(2)</b>	Bytes
<b>Average_bitrate</b>	<b>(16)</b>	<b>(2)</b>	Bytes/s
<b>Jitter</b>	<b>(8)</b>	<b>(1)</b>	ms
<i>}</i>			
<i>If (Field &amp;= session_binding_US_Included) &amp;&amp; (Aux_control_field != IPv6_add) { {</i>			
<b>NIU_client_source_IP_add</b>	<b>(32)</b>	<b>(4)</b>	
<b>US_session_binding_control</b>	<b>(32)</b>	<b>(4)</b>	
<b>NIU_client_destination_IP_add</b>	<b>(32)</b>	<b>(4)</b>	
<b>NIU_client_source_port</b>	<b>(16)</b>	<b>(2)</b>	
<b>NIU_client_destination_port</b>	<b>(16)</b>	<b>(2)</b>	
<b>Upstream_transport_protocol</b>	<b>(8)</b>	<b>(1)</b>	
<b>NIU_client_source_MAC_add</b>	<b>(48)</b>	<b>(6)</b>	
<b>NIU_client_destination_MAC_add</b>	<b>(48)</b>	<b>(6)</b>	
<b>Upstream_ethernet_protocol</b>	<b>(16)</b>	<b>(2)</b>	
<b>Upstream_session_Id</b>	<b>(32)</b>	<b>(4)</b>	
<i>}</i>			
<i>If (aux_control_Field &amp;= session_binding_DS_Included) &amp;&amp; (Aux_control_field != ipv6_add) { {</i>			
<b>DS_session_binding_control</b>	<b>(32)</b>	<b>(4)</b>	
<b>INA_client_source_IP_add</b>	<b>(32)</b>	<b>(4)</b>	
<b>INA_client_destination_IP_add</b>	<b>(32)</b>	<b>(4)</b>	
<b>INA_client_source_port</b>	<b>(16)</b>	<b>(2)</b>	
<b>INA_client_destination_port</b>	<b>(16)</b>	<b>(2)</b>	
<b>Downstream_transport_protocol</b>	<b>(8)</b>	<b>(1)</b>	
<b>INA_client_source_MAC_add</b>	<b>(48)</b>	<b>(6)</b>	
<b>INA_client_destination_MAC_add</b>	<b>(48)</b>	<b>(6)</b>	
<b>Downstream_ethernet_protocol</b>	<b>(16)</b>	<b>(2)</b>	
<b>Downstream_session_Id</b>	<b>(32)</b>	<b>(4)</b>	
<i>}</i>			
<i>}</i>			

Resource\_Request\_ID is an 8-bit unsigned integer which identifies the resource request. The value of the Resource\_Request\_ID is incremented by one for every new resource request of the NIU. **The value may not be 0.**

Connection\_ID is a 32-bit field which identifies the connection for which changes are requested. If the value of Connection\_ID is zero, a new connection is requested.

Aux\_control\_field\_included: if set to 1, the message control auxiliary control field.

Admit\_flag: if set to 1, the resources requested by the message should not be granted for the moment. The INA has to guarantee, that at the moment the resources were committed (admit\_flag = 0), the resources will be granted for the connection.

Priority\_included: if set to 1, the message includes a priority field.

Frame\_length\_included: if set to 1, the message includes a frame\_length field.

Session\_binding\_US\_Included: if set to 1, the message includes a session binding description for the upstream.

Release\_Requested: If set to one, the release of the connection is requested. In this case, all following parameters of the message shall be ignored by the INA.

Reservation\_ID\_Requested: If set to one, a Reservation\_ID is requested for the connection.

Cyclic\_Assignment\_Needed: If set to one, cyclic assignment is requested for fixed rate access for the connection. If Requested\_Bandwidth is zero, this field is ignored by the INA.

Requested\_Bandwidth: Gives the requested bandwidth for fixed rate access for the connection in slots/1 200 ms.

Maximum\_Distance\_Between\_Slots: Gives the requested maximum distance between assigned fixed rate slots. If Requested\_Bandwidth is zero, this field is ignored by the INA.

Encapsulation is an 8-bit field that indicates the type of encapsulation requested: {Direct\_IP, Ethernet\_MAC\_Bridging, PPP, reserved 3...7}.

*Aux\_control\_field:*

Reserved: 5-bits field, must be set to 0.

IPv6\_add: if set to true, the IP addresses at the session binding blocks are IPv6 compatible.

Flowspec\_DS\_included: if set to 1, indicates that the message includes a flowspec field for the downstream.

Session\_binding\_DS\_included: if set to 1, the message includes a session binding description for the upstream.

Connection\_ID: is a 32-bit field which identifies the connection for which changes are requested. If the value of Connection\_ID is zero, a new connection is requested. If the connection ID is not zero, but the INA can not attach a connection to the connection ID, the connection was requested for a packet cable session, and the connection\_ID is the gate number associated with the connection.

Priority: 1 byte field. The value of the field defines the priority of the connection. Connections with low priority field value can be reprovisioned in order to accommodate the requirements of connections with high priority field. Priority values will be given according to the following table.

Application	Priority values
Standard data flow applications	0-79
Applications with QoS requirements	80-200
High priority applications	201-255

*Upstream flow spec:*

The description of the upstream flow spec is done with three parameters:



**Frame\_length**: the number of consecutive slots that are required for the maximum packet size that will be sent through the connection in the upstream.

**Requested\_Bandwidth**: Gives the requested bandwidth for fixed rate access for the connection in slots/1 200 ms.

**Maximum\_Distance\_Between\_Slots**: Gives the requested maximum distance between assigned fixed rate slots. If **Requested\_Bandwidth** is zero, this field is ignored by the INA.

The INA MUST calculate the requested data rate and the allowed jitter in the following way:

The INA calculates the data rate by calculating the **average\_distance\_between\_slots**, requested by the NIU. If the INA allocates for the NIU the number of slots defined by **NIU\_frame\_length**, every **average\_distance\_between\_slots**, the NIU will not experience any jitter.

$$\text{Average\_distance\_between\_slots} = (\text{number\_of\_slots @ 1 200 ms} \times \text{max\_packet\_size}) / \text{requested\_bandwidth}.$$

The jitter every packet delivered by the NIU can tolerate is:

$$\text{Jitter} = \text{maximum\_distance\_between\_slots} - \text{average\_distance\_between\_slots}$$

When the INA allocates the slots for the NIU, it MUST take into consideration the BW requested by the NIU and the maximum delay.

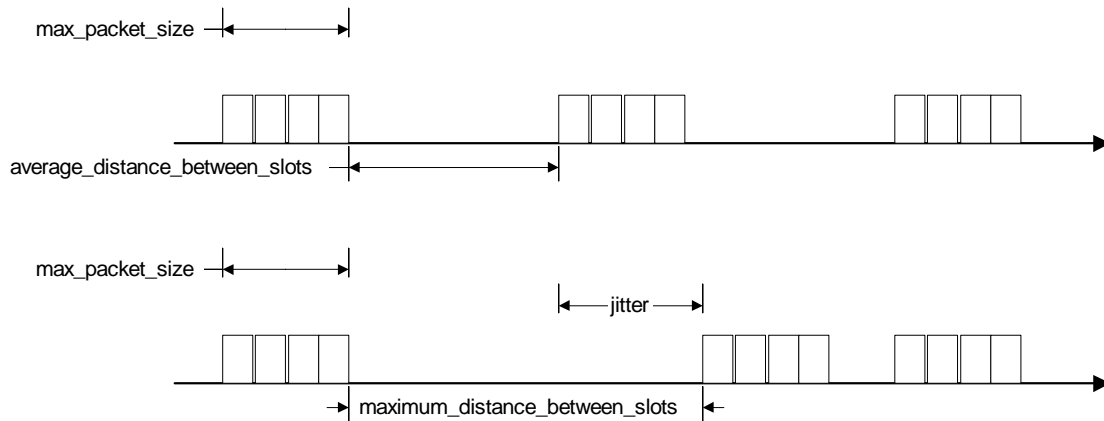

**Figure 41: Upstream Jitter Definition**

*Downstream flow spec (see clause 5.5.5.1):*

The downstream flow spec has three parameters:

**Max\_Packet\_size**: the size of the maximum packet (bytes) that will be sent through the connection in the downstream. The packet size includes propriety protocols header, transport protocol (UDP/TCP) header, and the IP header. The packet size does not include the Ethernet header.

**Average\_bitrate**: the average bit rate, in bytes/s.

**Jitter** the total jitter that downstream packets can experience.

*Session binding information (see clause 5.5.5.1):*

The upstream and downstream session binding blocks identify clients that are using the connection. The clients are identified by their source and destination, the source and destination ports (if relevant), and the protocol.

In most cases, the downstream and upstream session binding will be identical:

(NIU client source IP address = INA client destination IP address,  
 NIU client source port = INA client destination port,  
 and necessarily upstream protocol = downstream protocol).

In this case, only the downstream session binding is sent.

The message will contain a US session binding only if there is a difference in the INA and NIU source destination ports and addresses:

(NIU client source IP address  $\neq$  INA client destination IP address,  
NIU client source port  $\neq$  INA client destination port).

**US\_session\_binding\_control:** the interpretation of the US session binding block depends on the value of US\_session\_binding\_control field. The field acts as a bit map, indicating the existence of the different session binding parameters. If the bit attached to the session binding parameter, is set to 1, then the parameter exists in the message. If not, the session binding parameter does not exist. In case a bit indicating to a field that is not defined at the moment is set to 1, the NIU MUST treat the field as a 32-bit field long, and MAY ignore it.

The mapping between the current session binding parameters and the US\_session\_binding\_control field is described in Table 2.

US_session_binding_control bit number	US session binding parameter
0	NIU_client_source_IP_add
1	NIU_client_destination_IP_add
2	NIU_client_source_port
3	NIU_client_destination_port
4	Upstream_transport_protocol
5	<b>NIU_client_source_MAC_add</b>
6	<b>NIU_client_destination_MAC_add</b>
7	Upstream_ethernet_protocol
8	Upstream_session_Id
10-31	Reserved

NIU\_client\_source\_IP\_add: the IP source address of the NIU client.

NIU\_client\_destination\_IP\_add: the IP destination address of the INA client.

NIU\_client\_source\_port: the source port of the INA client.

NIU\_client\_destination\_port: the destination port of the INA client.

Upstream\_transport\_protocol: the transport protocol used by the NIU client .

NIU\_client\_source\_MAC\_add: a 48-bit unsigned integer that identifies the Ethernet MAC address of the NIU

client. NIU\_client\_destination\_MAC\_add: a 48-bit unsigned integer that identifies the destination Ethernet

MAC address of the NIU client. Upstream\_ethernet\_protocol: a 16-bit field, defining the internet protocol, as described in the ethernet header.

Upstream\_session\_Id: a 32-bit field, describing the session\_Id, as defined for PPPoE protocol.

**DS\_session\_binding\_control:** the interpretation of the DS session binding block depends on the value of DS\_session\_binding\_control field. The field acts as a bit map, indicating the existence of the different session binding parameters. If the bit attached to the session binding parameter, is set to 1, then the parameter exist. If not, the session binding parameter does not exist. In case a bit indicating to a field that is not defined at the moment is set to 1, the NIU MUST treat the field as a 32-bit field long, and MAY ignore it.

The mapping between the current session binding parameters and the DS\_session\_binding\_control field is described in Table 2.

DS_session_binding_contr bit number	DS session binding parameter
0	INA_client_source_IP_add
1	INA_client_destination_IP_add
2	INA_client_source_port
3	INA_client_destination_port
4	Downstream_transport_protocol
5	<b>INA_client_source_MAC_add</b>
6	<b>INA_client_destination_MAC_add</b>
7	Downstream_ethernet_protocol
8	Downstream_session_Id
10-31	Reserved

INA\_client\_source\_IP\_add: the IP source address of the INA client.

INA\_client\_destination\_IP\_add: the IP destination address of the INA client.

INA\_client\_source\_port: the source port of the INA client. INA\_client\_destination\_port: the destination port of the INA client.

Downstream\_transport\_protocol: the transport protocol used by the INA client .

INA\_client\_source\_MAC\_add: a 48-bit unsigned integer that identifies the Ethernet MAC address of the INA client.

INA\_client\_destination\_MAC\_add: a 48-bit unsigned integer that identifies the destination Ethernet MAC address of the INA client.

Downstream\_ethernet\_protocol: a 16-bit field, defining the internet protocol, as described in the ethernet header.

**Downstream\_session\_Id:** a 32-bit field, describing the session\_Id, as defined for PPPoE protocol.

#### <MAC> Resource Request Denied Message (Singlecast Downstream)

The INA may respond to a resource request of the NIU with a <MAC> Resource Request Denied Message:

**Table 35: Resource Request Denied Message Structure**

Resource_Request_Denied_Message() {	Bits	Bytes	Bit Number/Description
Resource_Request_ID	8	1	
}			

Resource\_Request\_ID is an 8-bit unsigned integer which identifies the resource request which is denied.

## 5.5.6 Connection Release

This clause defines the MAC signalling requirements for connection release. Figure 42 displays the signalling flow for releasing a connection. The NIU can request the release of a connection using the <MAC> **Resource Request Message**.

- 1) The NIU may request the release of a connection using the <MAC> **Resource Request Message**, or the INA itself can initiate the release process.
- 2) Upon receiving the <MAC> **Release Message** from the INA, the NIU shall tear down the upstream connection established for the specified Connection\_ID.
- 3) Upon teardown of the upstream connection, the NIU shall send the <MAC> **Release Response Message** on the upstream channel previously assigned for that connection. If the Connection\_ID is unknown by the NIU, it shall send zero in the response message. If the Number\_of\_Connections in the Connection Release Message is zero, then the NIU shall release all open connections.

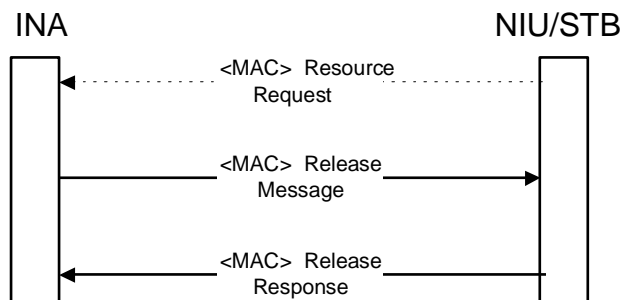

**Figure 42: Connection release signalling**

A more detailed description of the connection release process, including state diagrams and time outs, is given in clauses A.3 and A.5.

#### <MAC> Release Message (Singlecast Downstream)

The <MAC> Release Message is sent from the INA to the NIU to terminate a previously established connection.

**Table 36: Release Message Structure**

Release_Message(){	Bits	Bytes	Bit Number / Description
Number_of_Connections	8	1	
for(i=0;i<Number_of_Connections;i++){			
Connection_ID	(32)	(4)	
}			
}			

#### Connection ID

Connection\_ID is a 32-bit unsigned integer representing a global connection Identifier for the NIU Dynamic Connection.

#### <MAC> Release Response (Upstream contention or reserved)

The <MAC> RELEASE RESPONSE MESSAGE is sent by the NIU to the INA to acknowledge the release of a connection. The format of the message is shown in the following Table.

**Table 37: Release Response Message structure**

Release_Response_Message (){	Bits	Bytes	Bit Number / Description
Connection_ID	32	4	
}			

#### Connection ID

Connection\_ID is a 32-bit unsigned integer representing the global connection Identifier used by the NIU for this connection.

## 5.5.7 Fixed Rate Access

Fixed rate access is provided by the INA using the <MAC> Connect Message. The INA is also allowed to assign slots in fixed rate access to a connection in response to a <MAC> Reservation Request Message.

## 5.5.8 Contention Based Access

The NIU shall use contention based slots specified by the slot boundary definition fields (Rx) to transmit contention based messages or payload (see clause 5.3.1.3). The format of contention based MAC messages is described by the MAC message format (see clause 5.5.2.7). The format for payload transmission is described in clause 6.

## 5.5.9 Reservation Access

This clause defines the MAC signalling requirements for reservation access. Figure 43 displays the signalling flow for reserving an access.

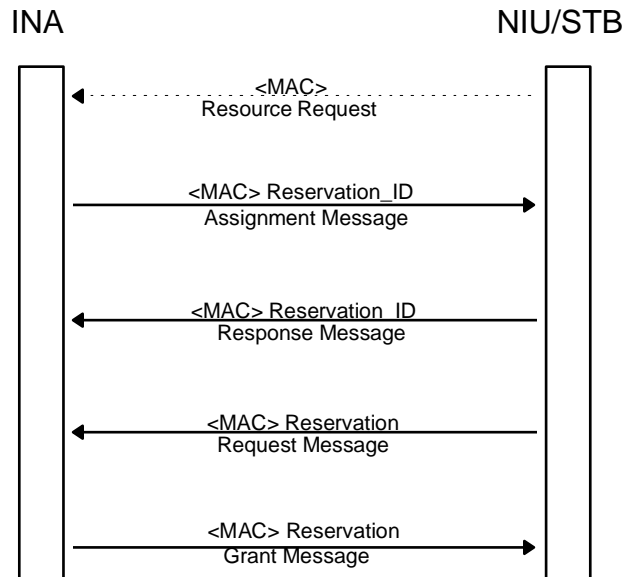

**Figure 43: Reservation access signalling**

- 1) The NIU can request a Reservation\_ID using the <MAC> Resource Request Message.
- 2) The NIU shall wait for a <MAC> Reservation ID Assignment Message from the INA before it can request reservation access and before it can send Piggy Back Reservation Requests.
- 3) At any time when needed after receiving the reservation ID, the NIU can request a certain number of slots to the INA using the <MAC> Reservation Request Message.
  - 3a) The INA shall respond to that message using the <MAC> Reservation Grant Message.
  - 3b) If the NIU has not received the <MAC> Reservation Grant Message before the Grant\_Protocol\_Timeout, it shall send a <MAC> Reservation Status Request to the INA. This leads back to 3 or 4.
- 4) At any time when needed after receiving the reservation ID, the NIU can request one of three prespecified number of slots (specified by the Piggy\_Back\_Request\_Values, which are set in the Reservation\_ID\_Assignment\_Message) by setting the two MSBs of the GFC contained in any Upstream ATM cell owned by given connection - to the correct corresponding value (01, 10 or 11; 00 indicates no requested Piggy Back reservation).
  - 4a) The INA shall respond to the Piggy Back request using the <MAC> Reservation Grant Message.
  - 4b) If the NIU has not received the <MAC> Reservation Grant Message before the Grant\_Protocol\_Timeout, it shall send a <MAC> Reservation Status Request to the INA. This leads back to 4 or 3.

- 4c) It is allowed to use "Continuous Piggybacking": Using this mechanism the NIU requests the minimum number slots possible (set of GFC\_xx\_Slots values) via a Piggybacking request in the last slot of an payload data upstream transmission even if no further data is in the upstream queue of the NIU. In the granted slot, an AAL5 frame with zero length can be sent upstream if no payload data is available. In this slot again a piggybacking request for the minimum possible number of slots can be issued. Instead of using the piggybacking indication with a zero payload AAL5 frame, it is also allowed to send a reservation request message in the upstream slot with Reservation\_Request\_Slot\_Count = 1. Short idle periods up to the length indicated in the Reservation ID Assignment Message can therefore be bridged without the need for contention access at the time where the next payload data is to be transferred. This improves the access delay, since the probability of collisions is avoided. On the other hand, some bandwidth might be wasted. It is up to the INA to set the maximum time for the bridging period (Continuous\_Piggy\_Timeout in the Reservation\_ID\_Assignment\_Message or the Configuration\_Message) by taking into account the tradeoff between throughput and access delay. A more detailed description of the reservation process, including state diagrams and time outs, is given in clauses A.4 and A.5.

#### <MAC> Reservation ID Assignment Message (Singlecast Downstream)

The <MAC> Reservation ID Assignment Message is used to assign the NIU a Reservation\_ID. In addition, the Reservation\_ID\_assignment\_message contains the three different reservation grant sizes used in the Piggy Back procedure and the timeout for continuous piggybacking. The NIU identifies its entry in the Reservation\_grant\_message by comparing the Reservation\_ID assigned to it by the Reservation\_ID\_assignment\_message and the entries in the Reservation\_Grant\_message.

The format of the message is given in Table 38.

**Table 38: Reservation ID assignment message structure**

Reservation_ID_Assignment_Message (){	Bits	Bytes	Bit Number / Description
Connection_ID	32	4	
Reservation_ID	16	2	
Grant_protocol_timeout	16	2	
Piggy_Back_Request_Values		4	
Continuous_Piggy_Back_Timeout	8		Unit is 9 ms
GFC_11_Slots	8		
GFC_10_Slots	8		
GFC_01_Slots	8		
}			

#### Connection ID

Connection\_ID is a 32-bit unsigned integer representing a global connection identifier for the NIU Dynamic Connection.

#### Reservation\_ID

Reservation\_ID is a 16-bit unsigned number representing an identifier for the connection. This is used as a short identifier by the NIU to identify the appropriate Reservation\_Grant\_Messages.

#### Grant\_protocol\_timeout

Grant\_protocol\_timeout is a 16-bit unsigned number representing the time in milliseconds that the NIU should wait before verifying the status of pending grants. This parameter specifies the time that the NIU should wait after receiving the last <MAC> Reservation\_grant\_message, with an entry addressed to the NIU, before initiating a reservation status request. If the NIU has pending grants and the timeout occurs, it should send the Reservation\_status\_request message to the INA. The INA will respond with the Reservation\_grant\_message (probably without granting any slots) to inform the NIU of any remaining slots left to be granted. This allows the NIU to correct any problems should they exist such as issuing an additional request for slots or waiting patiently for additional grants.

*Piggy\_Back\_Request\_Values*

*Continuous\_Piggy\_Back\_Timeout* is an 8-bit unsigned integer value representing the time period that can be bridged using the Continuous Piggybacking mechanism. The unit of the value is 9 ms. The timeout value indicates how long a NIU is allowed to request upstream slots with an empty payload data upstream queue after the first continuous piggybacking request was sent on the upstream channel. In order to offer an improved transmission performance (if the traffic characteristics are taken into account) a time period of up to 2,286 s can be bridged without using contention slots. If the value is set to zero, Continuous Piggybacking is disabled. If the value is set to 255, the timeout period is infinite.

*GFC\_11\_Slots* is an 8-bit unsigned value representing the number of slots being requested if the NIU sets the two MSBs of the GFC to a value of 11.

*GFC\_10\_Slots* is an 8-bit unsigned value representing the number of slots being requested if the NIU sets the two MSBs of the GFC to a value of 10.

*GFC\_01\_Slots* is an 8-bit unsigned value representing the number of slots being requested if the NIU sets the two MSBs of the GFC to a value of 01.

**<MAC> Reservation ID Response Message (Upstream contention or reserved)**

The <MAC> Reservation ID Response Message is used to acknowledge the receipt of the <MAC> *Reservation\_ID\_Assignment* message.

The format of the message is given below.

<b>Reservation_ID_Response_Message (){</b>	<b>Bits</b>	<b>Bytes</b>	<b>Bit Number/Description</b>
<b>Connection_ID</b>	<b>32</b>	<b>4</b>	
<b>Reservation_ID</b>	<b>16</b>	<b>2</b>	
}			

*Connection ID*

*Connection\_ID* is a 32-bit unsigned integer representing a global connection identifier for the NIU/STB Dynamic Connection.

*Reservation ID*

*Reservation\_ID* is a 16-bit unsigned number representing an identifier for the connection. This is used as a short identifier by the NIU/STB to identify the appropriate *Reservation\_Grant\_Messages*.

**<MAC> Reservation Request Message (Upstream contention or reserved)**

**Table 39: Reservation Request Message structure**

<b>Reservation_Request_message (){</b>	<b>Bits</b>	<b>Bytes</b>	<b>Bit Number / Description</b>
<b>Reservation_ID</b>	<b>16</b>	<b>2</b>	
<b>Reservation_request_slot_count</b>	<b>8</b>	<b>1</b>	
}			

This message is sent from the NIU to the INA.

*Reservation ID*

*Reservation\_ID* is a 16-bit unsigned number representing an identifier for the connection. This is used as a short identifier by the NIU to identify the appropriate *Reservation\_Grant\_Messages*.

*Reservation Request Slot Count*

*Reservation\_request\_slot\_count* is an 8-bit unsigned number representing the number of slots requested by the NIU. This is the number of sequential slots that will be allocated in the reservation region of the upstream channel. The INA will respond with the *Reservation\_Grant* message granting the request.

**<MAC> Reservation Grant Message (Broadcast Downstream)**

The <MAC> RESERVATION GRANT MESSAGE is used to indicate to the NIU which slots have been allocated in response to the Reservation Request message. The NIU identifies its entry in the Reservation\_grant\_message by comparing the Reservation\_ID assigned to it by the Reservation\_ID\_assignment\_message and the entries in the Reservation\_Grant\_message.

The format of the message is given in the following Table.

**Table 40: Reservation Grant Message structure**

<b>Reservation_grant_message ()</b>	<b>Bits</b>	<b>Bytes</b>	<b>Bit Number/ Description</b>
<b>Reference_slot</b>	<b>16</b>	<b>2</b>	
<b>Number_grants</b>	<b>8</b>	<b>1</b>	
<i>for (l=0; l&lt;Number_grants; l++){</i>			
<b>Reservation_ID</b>	<b>(16)</b>	<b>(2)</b>	
Grant_Slot_count	(4)	(2)	15...12
Remaining_slot_count	(5)		11...7
Grant_slot_offset	(7)		6...0
<i>}</i>			
<b>Number_of_US_Channels</b>	<b>8</b>	<b>1</b>	
<i>for(l=0; l&lt;Number_of_US_Channels;l++){</i>			
<b>Minislot_Control_Field</b>		<b>(1)</b>	
Upstream_Channel_Number	(3)		7...5
MS_Feedback_Included	(1)		4: {no, yes}
MS_Allocation_Included	(1)		3: {no, yes}
MS_16QAM_Enhancement_Included	(1)		2: {no, yes}
Reserved	(3)		1...0: shall be 0.
<i>if (MS_Feedback_Included    MS_Allocation_Included) {</i>			
<b>MS_Reference_Field</b>	<b>(16)</b>	<b>(2)</b>	
<i>}</i>			
<i>if (MS_Feedback_Included) {</i>			
<b>Number_of_Feedbacks</b>	<b>(8)</b>	<b>(1)</b>	
<i>for(l=0;l&lt;Number_of_Feedbacks; l++){</i>			
<b>Feedback_Offset</b>	<b>(8)</b>	<b>(1)</b>	
<b>Feedback_Collision_Number_1</b>	<b>(8)</b>	<b>(1)</b>	
<b>Feedback_Collision_Number_2</b>	<b>(8)</b>	<b>(1)</b>	
<b>Feedback_Collision_Number_3</b>	<b>(8)</b>	<b>(1)</b>	
<i>}</i>			
<i>}</i>			
<i>if (MS_Allocation_Included) {</i>			
<b>Entry_Field</b>		<b>(2)</b>	
Stack_Entry	(1)		15
Reserved	(3)		14...12
Entry_Spreading	(12)		11...0
<b>Number_of_Allocations</b>	<b>(8)</b>	<b>(1)</b>	
<i>for(l=0;l&lt;Number_of_Allocations; l++){</i>			
<b>Allocation_Offset</b>	<b>(8)</b>	<b>(1)</b>	
<b>Allocation_Collision_Number</b>	<b>(8)</b>	<b>(1)</b>	
<i>}</i>			
<i>}</i>			
<i>if ((MS_Feedback_Included)  (MS_allocation_included)) &amp;&amp; (MS_16QAM_Enhancement_Included) {</i>			
<b>Number_of_Feedbacks</b>	<b>(8)</b>	<b>(1)</b>	
<i>for(l=0;l&lt;Number_of_Feedbacks; l++){</i>			
<b>Feedback_Offset</b>	<b>(8)</b>	<b>(1)</b>	
<b>Feedback_Collision_Number_4</b>	<b>(8)</b>	<b>(1)</b>	
<b>Feedback_Collision_Number_5</b>	<b>(8)</b>	<b>(1)</b>	
<b>Feedback_Collision_Number_6</b>	<b>(8)</b>	<b>(1)</b>	
<i>}</i>			
<i>}</i>			
<i>if (MS_allocation_Included) &amp;&amp; (MS_16QAM_Enhancement_Included) {</i>			



<b>Reservation_grant_message (){</b>	<b>Bits</b>	<b>Bytes</b>	<b>Bit Number/ Description</b>
<b>Number_of_Allocations</b>			
<i>for(l=0;l&lt;Number_of_Allocations; l++) {</i>			
<b>Allocation_Offset</b>	<b>(8)</b>	<b>(1)</b>	
<b>Allocation_Collision_Number_Set2</b>	<b>(8)</b>	<b>(1)</b>	
<i>}</i>			
<i>}</i>			
<i>}</i>			
<i>}</i>			

### *Reference\_slot*

*Reference\_slot* is an 16-bit unsigned number indicating the reference point for the remaining parameters of this message. This represents a physical slot of the upstream channel. Since the upstream and downstream slots are not aligned, the INA shall send this message in a downstream slot such that it is received by the NIU before the *Reference\_slot* exists on the upstream channel. Only 13 lowest significant bits shall be considered. 3 MSB are reserved for future used.

### *Number\_grants*

*Number\_grants* is an 8-bit unsigned number representing the number of grants contained within this message. This can either correspond to grants for different NIUs, or to different *connection\_IDs* for the same NIU.

### *Reservation\_ID*

*Reservation\_ID* is a 16-bit unsigned number representing an identifier for the connection. This is used as a short identifier by the NIU to identify the appropriate *Reservation\_Grant\_Messages*.

### *Grant\_slot\_count*

*Grant\_slot\_count* is a 4-bit unsigned number representing the number of sequential slots currently granted for the upstream burst. A value of zero indicates that no slots are being granted. This would typically be the case in a response to a *Reservation\_status\_request* message.

Upon receipt of this message the NIU is assigned *Grant\_slot\_count* sequential slots in the region of the upstream channel starting at the position indicated by the *Reference\_slot* and *Grant\_slot\_offset* values (jumps are needed in the case where the number of slots granted exceeds the length of this region).

### *Remaining\_slot\_count*

*Remaining\_slot\_count* is a 5-bit unsigned number representing the remaining slots to be granted by the INA with subsequent grant messages. A value of 0x1f indicates that 31 or more slots will be made available in the future. A value of 0x00 indicates that no additional slots will be granted in the future and that the slots granted in this message represent the only remaining slots available for the connection. The NIU should monitor this count to determine if sufficient slots remain to satisfy current needs. Should additional slots be required because of lost grant messages or additional demand, additional slots should be requested using the *Reservation\_request\_message*. Additional *Reservation\_request\_messages* shall be sent only when the *Remaining\_slot\_count* is less than 15. To minimize contention on the upstream channel, the *Reservation\_request\_message* may be sent in one of the slots granted by the *Reservation\_grant\_message*. The remaining slot count is calculated for each grant in a *Reservation Grant* message.

### *Grant\_slot\_offset*

*Grant\_slot\_offset* is a 7-bit unsigned number representing the starting slot to be used for the upstream burst. This number is added to the *Reference\_slot* to determine the actual physical slot.

### *Number\_of\_US\_Channels*

*Number\_of\_Channels* is a 8-bit unsigned integer representing the number of Upstream channels in this message.

### *Minislot\_Control\_Field*

*Upstream\_Channel\_Number* is a 3-bit unsigned integer representing the upstream channel concerned by this iteration.

`MS_Feedback_Included` is a boolean that indicates that Minislot Feedback Section is included in the message.

`MS_Allocation_Included` is a boolean that indicates that Minislot Allocation Section is included in the message.

`MS_16QAM_Enhancement_Included` is a boolean that indicates that for 16QAM upstream modulation the minislot feature is used with two sets of 3 minislots each that are embedded in one 128 bytes upstream packet.

#### *Minislot\_Reference\_Field*

`Minislot_Reference_Field` is a 16-bit field of which the 13 LSBs represent the reference ATM slot number.

#### *Number\_of\_Feedbacks*

`Number_of_Feedbacks` is a 8-bit unsigned integer representing the number of three minislot feedback groups included.

#### *Feedback\_Offset*

`Feedback_Offset` is a 8-bit unsigned integer representing the offset of the group of three minislots in full slots. This number is added to the `Minislot_Reference_Field` to determine the actual physical slot.

#### *Feedback\_Collision\_Number\_1*

`Feedback_Collision_Number_1` is a 8-bit unsigned integer representing the first minislot collision identification in the group of three minislots. The values 0xFF and 0xFE represent for idle and successful transmission, respectively. Other values are called `Collision_Number` and are used to resolve contentions (see `Allocation_Collision_Number` field).

#### *Feedback\_Collision\_Number\_2*

`Feedback_Collision_Number_2` is a 8-bit unsigned integer representing the second minislot collision identification in the group of three minislots. The values 0xFF and 0xFE represent for idle and successful transmission, respectively. Other values are called `Collision_Number` and are used to resolve contentions (see `Allocation_Collision_Number` field).

#### *Feedback\_Collision\_Number\_3*

`Feedback_Collision_Number_3` is a 8-bit unsigned integer representing the third minislot collision identification in the group of three minislots. The values 0xFF and 0xFE represent for idle and successful transmission, respectively. Other values are called `Collision_Number` and are used to resolve contentions (see `Allocation_Collision_Number` field).

#### *Entry\_Field*

`Stack_Entry` is a boolean parameter. When it is set to 0, collision resolution is according to the tree algorithm (see clause 5.5.4) and NIUs with new requests have to wait for mini-slots with the `Allocation_Collision_Number` equal to 0 to enter the request contention process. When `Stack_Entry` is set to one, NIUs with new requests can enter the request contention process in any minislot (independent of the value of `Allocation_Collision_Number`). After entering in this way to the contention process, the collision resolution is identical to the tree mode. So, the difference between `Stack_Entry` set to 0 or 1 is that in the latter case NIUs do not have to wait for minislots with `Allocation_Collision_Number` equal to 0 before they can start sending a new request in contention mode.

`Entry_Spreading` is a 14-bit unsigned integer that is used to control the number of NIUs that enter the request contention process in minislots. The NIU generates a random number between 0 and `Entry_Spreading` (the random number generator in the NIU shall have a uniform distribution). If this number falls within the window from 0 to 2, then the NIU contends for access in the corresponding minislot, otherwise it will not transmit a request but wait for the next appropriate set of minislots and follow the same procedure again.

#### *Number\_of\_Allocations*

`Number_of_Allocations` is a 8-bit unsigned integer representing the number of contention resolution allocations included.

#### *Allocation\_Offset*

`Allocation_Offset` is a 8-bit unsigned integer representing the offset of the group of three minislots in full slots to be added to the `Minislot_Reference_Field` to determine the physical slot number of the group of three minislots.

*Allocation\_Collision\_Number*

*Allocation\_Collision\_Number* is a 8-bit unsigned integer associated with the group of three minislots. Only NIUs having their *Collision\_Number* equal to *Allocation\_Collision\_Number* are allowed to transmit in these minislots.

*Number\_of\_Feedbacks*

*Number\_of\_Feedbacks* is a 8-bit unsigned integer representing the number of three minislot feedback groups included.

*Feedback\_Offset*

*Feedback\_Offset* is a 8-bit unsigned integer representing the offset of the second group of three minislots in full slots. This number is added to the *Minislot\_Reference\_Field* to determine the actual physical slot.

*Feedback\_Collision\_Number\_4*

*Feedback\_Collision\_Number\_4* is a 8-bit unsigned integer representing the fourth minislot collision identification in the group of three minislots. The values 0xFF and 0xFE represent for idle and successful transmission, respectively. Other values are called *Collision\_Number* and are used to resolve contentions (see *Allocation\_Collision\_Number* field).

*Feedback\_Collision\_Number\_5*

*Feedback\_Collision\_Number\_5* is a 8-bit unsigned integer representing the fifth minislot collision identification in the group of three minislots. The values 0xFF and 0xFE represent for idle and successful transmission, respectively. Other values are called *Collision\_Number* and are used to resolve contentions (see *Allocation\_Collision\_Number* field).

*Feedback\_Collision\_Number\_6*

*Feedback\_Collision\_Number\_6* is a 8-bit unsigned integer representing the sixth minislot collision identification in the group of three minislots. The values 0xFF and 0xFE represent for idle and successful transmission, respectively. Other values are called *Collision\_Number* and are used to resolve contentions (see *Allocation\_Collision\_Number* field).

*Number\_of\_Allocations*

*Number\_of\_Allocations* is a 8-bit unsigned integer representing the number of contention resolution allocations included.

*Allocation\_Offset*

*Allocation\_Offset* is a 8-bit unsigned integer representing the offset of the second group of three minislots in full slots to be added to the *Minislot\_Reference\_Field* to determine the physical slot number of the group of three minislots.

*Allocation\_Collision\_Number\_Set2*

*Allocation\_Collision\_Number\_Set2* is a 8-bit unsigned integer associated with the second group of three minislots. Only NIUs having their *Collision\_Number* equal to *Allocation\_Collision\_Number\_Set2* are allowed to transmit in these minislots.

**<MAC> Reservation Status Request (Upstream contention or reserved)**

The <MAC> RESERVATION STATUS REQUEST Message is used to determine the status of the outstanding grants to be assigned by the INA. This message is only sent after the Grant protocol time-out is exceeded. The INA will respond with the *Reservation\_grant\_message* (possibly without granting any slots) to inform the NIU of any remaining slots left to be granted. This allows the NIU to correct any problems should they exist such as issuing an additional request for slots or waiting patiently for additional grants.

The format of the message is given in Table 41.

**Table 41: Reservation status request message structure**

<b>Reservation_Status_Request_Message (){</b>	<b>Bits</b>	<b>Bytes</b>	<b>Bit Number/Description</b>
<b>Reservation_ID</b>	<b>16</b>	<b>2</b>	
<b>Remaining_request_slot_count</b>	<b>8</b>	<b>1</b>	
<b>}</b>			

*Reservation\_ID*

*Reservation\_ID* is a 16-bit unsigned number representing an identifier for the connection. This is used as a short identifier by the NIU to identify the appropriate *Reservation\_Grant\_Messages*.

*Remaining\_request\_slot\_count*

*Remaining\_request\_slot\_count* is an 8-bit unsigned number representing the number of slots that the NIU is expecting to be granted.

## 5.5.10 MAC Link Management

The MAC Link Management tasks provide continuous monitoring and optimization of upstream resources. These functions include:

- Power and Timing Management;
- Fixed rate Allocation Management;
- Channel Error Management.

### 5.5.10.1 Power, Timing and Equalizer Management

The procedure shall provide continuous monitoring of upstream transmission from the NIU. The **<MAC> Ranging and Power Calibration Message** is used to maintain a NIU within predefined thresholds of power and time, and to adjust the pre equalizer coefficients.

The Upstream Burst Demodulator shall continuously monitor the upstream burst transmissions from an NIU. Upon detection of an NIU outside the predefined range, the INA shall send the **<MAC> Ranging and Power Calibration Message** to the NIU.

The pre-equalizer coefficients should be typically updated only when the INA recognizes that the channel response was changed.

The NIU/STB upstream power accuracy shall be better than or equal to  $\pm 1,5$  dB. The NIU/STB power resolution shall be 0,5 dB nominally.

A detailed description of the recalibration process, including state diagrams and time outs, is given in clause A.6.

### 5.5.10.2 TDMA Allocation Management

To ensure optimum assignment of TDMA resources, the INA shall ensure the upstream allocation of TDMA resources for various connections remain intact when allocating resources to a new connection. However, in the event that reconfiguration is required to minimize fragmentation of resources, then the INA shall dynamically reconfigure the upstream TDMA assignments to a NIU or group of NIUs. The **<MAC> Reprovision Message** is utilized to change previously established connection parameters.

The NIU can request the change of some parameters of existing connections by use of the **<MAC> Resource Request Message**, in which case the **<MAC> Reprovision Message** can be used by the INA to confirm the requested changes.

A detailed description of the reprovisioning process, including state diagrams and time outs, is given in clauses A.5 and A.7.

For a description of upstream and downstream frequency changes, see clause 5.5.2.2.

**<MAC> Reprovision Message (Singlecast Downstream)**

The <MAC> REPROVISION MESSAGE is sent by the INA to the NIU to:

- Reassign upstream resources (maintaining the originally requested QoS parameters at the establishment of the connection)
- Re-provision the NIU from one INA to another INA
- Re-provisioning the NIU within one INA
- Change connection parameters

When this message is sent in order to change the QoS parameters of a connection, it should refer only to 1 connection (since the `new_frame_length` parameter refers to all the connections in the message).

Two levels of re-provision can be supported by the NIU; Basic and extended re-provision. Extended re-provision is provided for re-provision the NIU from one INA to another and/or change the connection parameters. The following parameter groups are supported only by NIU that supports extended re-provision (according to its `NIU_Capabilities`):

- Minimum Reservation Length
- Maximum Contention Length
- New Connection parameters
- New DS parameters

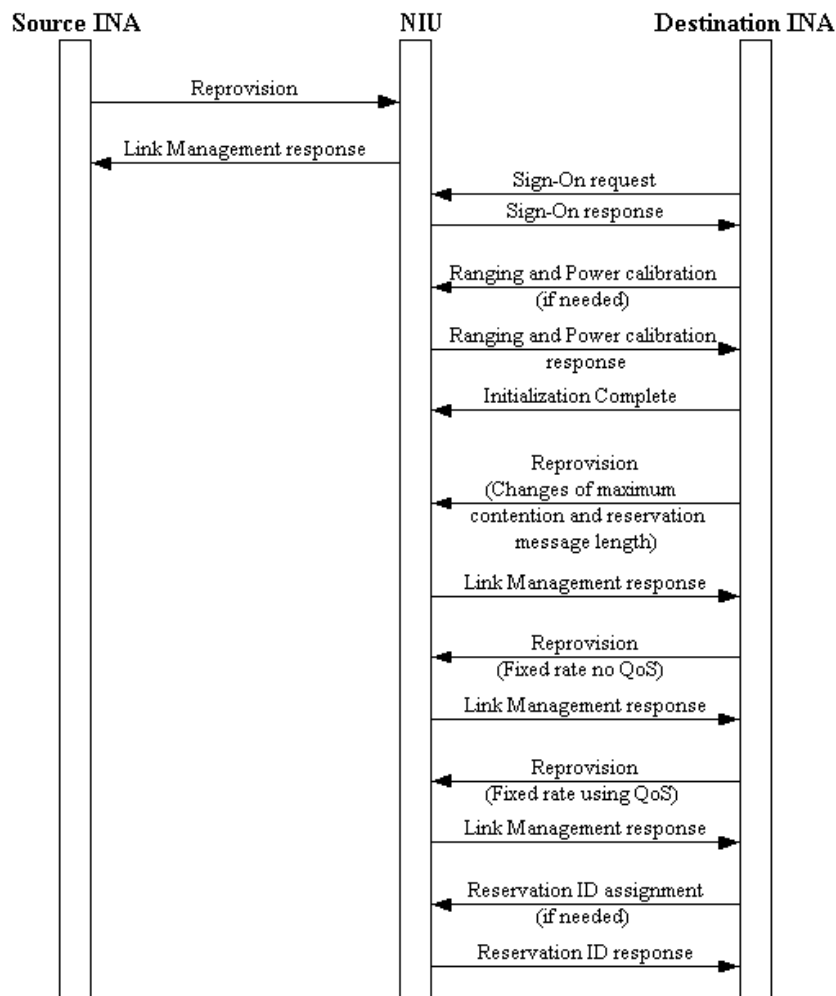

Figure 44: Example MAC message flow to re-provision a NIU from one INA to another INA

Table 42: Reprovision Message structure

Reprovision_Message (){	Bits	Bytes	Bit Number/ Description
<b>Reprovision_Control_Field</b>		<b>1</b>	
Reprovision_Control_aux_field_included	1		7 : {no, yes}
Delete_Reservation_IDs	1		6 : {no, yes}
New_Downstream_IB_Frequency	1		5 : {no, yes}
New_Downstream_OOB_Frequency	1		4 : {no, yes}
New_Upstream_Frequency_Included	1		3 : {no, yes}
New_Frame_Length_Included	1		2 : {no, yes}
New_Cyclical_Assignment_Included	1		1 : {no, yes}
New_Slot_List_Included	1		0 : {no, yes}
<i>if (Reprovision_Control_Field &amp;= New_Downstream_IB_Frequency) {</i>			
<b>New_Downstream_IB_Frequency</b>	<b>(32)</b>	<b>(4)</b>	
<i>}</i>			
<i>if (Reprovision_Control_Field &amp;= New_Downstream_OOB_Frequency) {</i>			
<b>New_Downstream_OOB_Frequency</b>	<b>(32)</b>	<b>(4)</b>	
<b>DownStream_Type</b>	<b>(8)</b>	<b>(1)</b>	
<i>}</i>			
<i>if (Reprovision_Control_Field &amp;= New_Upstream_Frequency_Included) {</i>			
<b>New_Upstream_Frequency</b>	<b>(32)</b>	<b>(4)</b>	
<b>New Upstream Parameters</b>		<b>(2)</b>	

Reprovision_Message (){	Bits	Bytes	Bit Number/ Description
New_Upstream_Channel Number	(3)		15...13
Reserved	(2)		12...11
Upstream_Rate	(3)		10...8: enum
MAC_Flag_Set	(5)		7...3
Upstream_Modulation	(3)		2...0: enum
}			
<i>if (Reprovision_Control_Field &amp;=</i> <i>New_Frame_Length_Included){</i>			
<b>New_Frame_Length</b>	<b>(16)</b>	<b>(2)</b>	<b>9-0 : Unsigned</b>
}			
<i>if (Reprovision_Control_Field &amp;=</i> <i>New_Slot_List_Included   </i> <i>New_Cyclical_Assignment_Included   </i> <i>Delete_Reservation_IDs){</i>			
<b>Number_of_Connections</b>	<b>(8)</b>	<b>(1)</b>	
<i>for(i=0;i&lt;Number_of_Connections;i++){</i>			
<b>Connection_ID</b>	<b>(32)</b>	<b>(1)</b>	
<i>if(Reprovision_Control_Field &amp;=</i> <i>new_slot_list_included){</i>			Fixed Rate Access
<b>Number_Slots_Defined</b>	<b>(8)</b>	<b>(1)</b>	
<i>for(i=0;i&lt;Number_Slots_Assigned;i++){</i>			
<b>Slot_Number</b>	<b>(16)</b>	<b>(2)</b>	
}			
}			
<i>if (Reprovision_Control_Field &amp;=</i> <i>new_cyclic_Assignment_included){</i>			Fixed Rate Access
<b>Fixedrate_Start</b>	<b>(16)</b>	<b>(2)</b>	
<b>Fixedrate_Dist</b>	<b>(16)</b>	<b>(2)</b>	
<b>Fixedrate_End</b>	<b>(16)</b>	<b>(2)</b>	
}			
}			
<i>if (Reprovision_Control_Field &amp;= Control_aux_field_included){</i>			
<b>Reprovision_Control_aux_field</b>		<b>(2)</b>	
Reserved	7		15...9: shall be 0
New_Maximum_Reservation_Length	(1)		8: {no,yes}
New_Maximum_Contention_Length	(1)		7: {no,yes}
New_Connections_Specified	(1)		6: {no,yes}
New_DS_Specified	(1)		5: {no,yes}
IPv6_add	1		4: {no,yes}
New_priority_included	1		3 : {no,yes}
New_DS_flowspec_included	1		2 : {no,yes}
New_US_session_binding_included	1		1 : {no,yes}
New_DS_session_binding_included	1		0 : {no,yes}
}			
<i>if (Reprovision_Control_aux_Field &amp;= new_priority_included){</i>			
<b>Priority</b>	<b>(8)</b>	<b>(1)</b>	
}			
<i>if (Reprovision_Control_aux_Field &amp;=</i> <i>new_DS_flowspec_included){</i>			
<b>Max_packet_size</b>	<b>(16)</b>	<b>(2)</b>	Bytes
<b>Average_bitrate</b>	<b>(16)</b>	<b>(2)</b>	Bytes/s
<b>Jitter</b>	<b>(8)</b>	<b>(1)</b>	Msec
}			
<i>if (Reprovision_Control_aux_Field &amp;=</i> <i>new_US_session_binding_included) )&amp;&amp;</i> <i>(Reprovision_Control_aux_field!= IPv6_add) {</i>			
<b>US_session_binding_control</b>	<b>(32)</b>	<b>(4)</b>	
<b>NIU_client_source_IP_add</b>	<b>(32)</b>	<b>(4)</b>	
<b>NIU_client_destination_IP_add</b>	<b>(32)</b>	<b>(4)</b>	
<b>NIU_client_source_port</b>	<b>(16)</b>	<b>(2)</b>	
<b>NIU_client_destination_port</b>	<b>(16)</b>	<b>(2)</b>	
<b>Upstream_transport_protocol</b>	<b>(8)</b>	<b>(1)</b>	

Reprovision_Message (){	Bits	Bytes	Bit Number/ Description
NIU_client_source_MAC_add	(48)	(6)	
NIU_client_destination_MAC_add	(48)	(6)	
Upstream_ethernet_protocol	(16)	(2)	
Upstream_session_Id	(32)	(4)	
}			
if (Reprovision_Control_aux_Field &= new_DS_session_binding_included){			
DS_session_binding_control	(32)	(4)	
INA_client_source_IP_add	(32)	(4)	
INA_client_destination_IP_add	(32)	(4)	
INA_client_source_port	(16)	(2)	
INA_client_destination_port	(16)	(2)	
Downstream_transport_protocol	(8)	(1)	
INA_client_source_MAC_add	(48)	(6)	
INA_client_destination_MAC_add	(48)	(6)	
Downstream_ethernet_protocol	(16)	(2)	
Downstream_session_Id	(32)	(4)	
}			
if (Reprovision_Control_Aux_Field &= New_DS_Specified){			
Reserved	(4)		7...4
New_DS_Modulation	(4)		3...0
New_DS_Symbol_Rate	(32)	(4)	
}			
if (Reprovision_Control_Aux_Field &= New_Connections_Specified){			
Connections	(8)	(1)	
for(i = 0; i < Connections; i++){			
Old_Connection_ID	(32)	(4)	
New_Connection_ID	(32)	(4)	
New_PID	(16)	(2)	
New_DSM-CC_MAC	(48)	(6)	
New_DS_VC	(24)	(3)	
New_US_VC	(24)	(3)	
}			
}			
if (Reprovision_Control_Aux_Field &= New_Maximum_Contention_Length){			
Maximum_Contention_Access_Message_Length	(8)	(1)	
}			
if (Reprovision_Control_Aux_Field &= New_Maximum_Reservation_Length){			
Maximum_Reservation_Access_Message_Length	(8)	(1)	
}			
}			

### Reprovision Control Field

Reprovision\_Control\_Field specifies what modifications to upstream resources are included. It consists of the following subfields:

Reprovision\_Control\_aux\_field\_included: if set to 1, indicates that the message includes an auxiliary control field.

Delete\_Reservation\_IDs is a Boolean that indicates that the NIU/STB shall delete all Reservation\_IDs that have been assigned to the Connection\_IDs contained in this message.

New\_Downstream\_IB\_Frequency is a boolean that indicates that a new downstream IB frequency is specified in the message.

New\_Downstream\_OOB\_Frequency is a boolean that indicates that a new downstream OOB frequency is specified in the message.



`New_Upstream_Frequency_Included` is a boolean that indicates that a new upstream frequency is specified in the message.

`New_Frame_Length_Included` is a boolean that indicates that a new upstream frame is specified in the message. In the Reprovision Message the `Frame_Length` is a global value which applies to all `connection_ID` referred in this message.

`New_Cyclical_Assignment_Included` is a boolean that indicates that a new cyclical assignment is specified in the message. If the connection has already cyclic fixed rate slots or a slot list assigned, these slots are lost. Having Cyclical Assignments and Slot List Assignments for the same `Connect_ID` at the same time is not allowed.

`New_Slot_List_Included` is a boolean that indicates that a new slot list is specified in the message. If the connection has already cyclic fixed rate slots or a slot list assigned, these slots are lost. Having Cyclical Assignments and Slot List Assignments for the same `Connect_ID` at the same time is not allowed.

#### *New Downstream IB Frequency*

`New_Downstream_IB_Frequency` is a 32-bit unsigned integer representing the reassigned downstream IB carrier center frequency. The unit of measure is Hertz.

#### *New Downstream OOB Frequency*

`New_Downstream_OOB_Frequency` is a 32-bit unsigned integer representing the reassigned downstream OOB carrier center frequency. The unit of measure is Hertz.

#### *DownStream Type*

`DownStream_Type` is an 8-bit enumerated type indicating the modulation format for the down stream connection. { reserved, QPSK\_1,544, QPSK\_3,088, 3...255 reserved }

#### *New Upstream Frequency*

`New_Upstream_Frequency` is a 32-bit unsigned integer representing the reassigned upstream carrier center frequency. The unit of measure is Hertz.

#### *New Upstream Parameters*

`New_Upstream_Channel_Number` is a 3-bit unsigned integer which identifies the new logical channel (denoted by 'c') assigned to the NIU/STB. Refer to clause 5.3.2.1 for the use of this parameter.

`Upstream_Rate` is an 3-bit enumerated type indicating the upstream transmission grade for the upstream connection. { `Upstream_A_AQ`, `Upstream_B_BQ`, `Upstream_C_CQ`, `Upstream_D_DQ`, 4...7 reserved }

`MAC_Flag_Set` is an 5-bit field representing the first MAC Flag set assigned to the new logical channel. A downstream channel contains information for each of its associated upstream channel. This information is contained within structures known as MAC Flag Sets represented by either 24-bits (denoted b0...b23) or by 3 bytes (denoted Rxa, Rxb, Rxc). This information is uniquely assigned to a given upstream channel. Refer to clauses 5.3.1.3 and 5.3.2.1 for the use of this parameter.

`Upstream_Modulation`: 3-bit field enumerated type indicating the upstream channel modulation { QPSK, 16QAM, 2...7 reserved }

#### *New Frame Length*

`New_Frame_Length` is a 16-bit unsigned integer representing the size of the reassigned upstream Fixed rate based frame. The unit of measure is in slots. `New_Frame_Length` is valid only for `connect_IDs` that are contained in this message.

#### *Number of Slots Defined*

`Number_Slots_Defined` is an 8-bit unsigned integer that represents the number of slot assignments contained in the message. The unit of measure is slots.

*Slot Number*

Slot\_Number is a 16-bit unsigned integer that represents the Fixed rate based Slot Number assigned to the Network Interface Unit. Only 13 lowest significant bits shall be considered. 3 MSB are reserved for future used.

*Fixed rate Start*

Fixedrate\_Start - This 16-bit unsigned number represents the starting slot within the fixed rate access region that is assigned to the NIU. The NIU may use the next Frame\_length slots of the fixed rate access regions. Only 13 lowest significant bits shall be considered. 3 MSB are reserved for future used.

*Fixed rate Distance*

Fixedrate\_Distance - This 16-bit unsigned number represents the distance in slots between additional slots assigned to the NIU. The NIU is assigned all slots that are a multiple of Fixedrate\_Distance from the Fixedrate\_Start\_slot which do not exceed Fixedrate\_End\_slot. The NIU may use the next Frame\_length slots of the fixed rate access regions from each of these additional slots.

*Fixed rate End*

Fixedrate\_End - This 16-bit unsigned number indicates the last slot that may be used for fixed rate access. The slots assigned to the NIU, as determined by using the Fixedrate\_Start\_slot, the Fixedrate\_Distance and the Frame\_length, cannot exceed this number. Only 13 lowest significant bits shall be considered. 3 MSB are reserved for future use.

*Reprovision\_Control\_aux\_field*

Reserved: 7-bit field, must be set to 0.

New\_Maximum\_Reservation\_Length is a Boolean that indicates a new maximum reservation access message length specification is present in the message (part of extended re-provision capability).

New\_Maximum\_Contention\_Length is a Boolean that indicates a new maximum contention access message length specification is present in the message (part of extended re-provision capability).

New\_Connections\_Specified is a Boolean that indicates a connection mapping Table is present in the message (part of extended re-provision capability).

New\_DS\_Specified is a Boolean that indicates a new downstream specification is present in the message (part of extended re-provision capability).

IPv6\_add: if set to 1, the IP addresses at the session binding blocks are IPv6 compatible.

New\_priority\_included: if set to 1, a new priority is sent for the connection.

New\_DS\_flowspec\_included: if set to 1, indicates that the message includes a new flow spec field for the downstream.

New\_US\_session\_binding\_included: if set to 1, the message includes a session binding description for the upstream.

New\_DS\_session\_binding\_included: if set to 1, the message includes a session binding description for the downstream.

Priority: 1 byte field. The value of the field defined the priority of the connection. Connections with low priority field value can be reprovisioned in order to accommodate the requirements of connection with high priority field. Priority values will be given according to the following Table.

Application	Priority values
Standard data flow applications	0-79
Applications with QoS requirements	80-200
High priority applications	201-255

*Downstream flow spec (see clause 5.5.5.1):*

The downstream flow spec has 3 parameters:

**Max\_Packet\_size**: the size of the maximum packet (bytes) that will be sent through the connection in the downstream. The packet size will be calculated with the overhead created by layer 3 header and above. Meaning that the packet size includes propriety protocols header, transport protocol (UDP/TCP) header, and the IP header. The packet size does not include the Ethernet header.

**Average\_bitrate**: the average bit rate, in bytes/s.

**Jitter**: the total jitter a downstream packet may experience.

*Session binding information (see clause 5.5.5.1):*

The upstream and downstream session binding blocks identify clients that are using the connection. The clients are identified by their source and destination, the source and destination ports (if relevant), and the protocol.

In most cases, the downstream and upstream session binding will be identical:

(NIU client source IP address = INA client destination IP address,  
NIU client source port = INA client destination port,  
and necessarily upstream protocol = downstream protocol).

In this case, only the downstream session binding is sent.

The message will contain a US session binding only if there is a difference in the INA and NIU source destination ports and addresses:

(NIU client source IP address  $\neq$  INA client destination IP address,  
NIU client source port  $\neq$  INA client destination port ).

**US\_session\_binding\_control**: the interpretation of the US session binding block depends on the value of **US\_session\_binding\_control** field. The field acts as a bit map, indicating the existence of the different session binding parameters. If the bit attached to the session binding parameter, is set to 1, then the parameter exists in the message. If not, the session binding parameter does not exist. In case a bit indicating to a field that is not defined at the moment is set to 1, the NIU MUST treat the field as a 32-bit field long, and MAY ignore it.

The mapping between the current session binding parameters and the **US\_session\_binding\_control** field is described in Table 2.

<b>US_session_binding_control bit number</b>	<b>US session binding parameter</b>
0	NIU_client_source_IP_add
1	NIU_client_destination_IP_add
2	NIU_client_source_port
3	NIU_client_destination_port
4	Upstream_transport_protocol
5	<b>NIU_client_source_MAC_add</b>
6	<b>NIU_client_destination_MAC_add</b>
7	Upstream_ethernet_protocol
8	Upstream_session_Id
10-31	Reserved

**NIU\_client\_source\_IP\_add**: the IP source address of the NIU client.

**NIU\_client\_destination\_IP\_add**: the IP destination address of the INA client.

**NIU\_client\_source\_port**: the source port of the INA client. **NIU\_client\_destination\_port**: the destination port of the INA client. **Upstream\_transport\_protocol**: the transport protocol used by the NIU client (UDP/TCP). **NIU\_client\_source\_MAC\_add**: a 48-bit unsigned integer that identifies the Ethernet MAC address of the NIU client.

**NIU\_client\_destination\_MAC\_add**: a 48-bit unsigned integer that identifies the destination Ethernet MAC address of the NIU client.

**Upstream\_ethernet\_protocol**: a 16-bit field, defining the internet protocol, as described in the ethernet header.

**Upstream\_session\_Id**: a 32-bit field, describing the session\_Id, as defined for PPPoE protocol.

**DS\_session\_binding\_control**: the interpretation of the DS session binding block depends on the value of DS\_session\_binding\_control field. The field acts as a bit map, indicating the existence of the different session binding parameters. If the bit attached to the session binding parameter, is set to 1, then the parameter exist. If not, the session binding parameter does not exist. In case a bit indicating to a field that is not defined at the moment is set to 1, the NIU MUST treat the filed as a 32-bit field long, and MAY ignore it.

The mapping between the current session binding parameters and the DS\_session\_binding\_control field is described in Table 2.

DS_session_binding_contr bit number	DS session binding parameter
0	INA_client_source_IP_add
1	INA_client_destination_IP_add
2	INA_client_source_port
3	INA_client_destination_port
4	Downstream_transport_protocol
5	INA_client_source_MAC_add
6	INA_client_destination_MAC_add
7	Downstream_ethernet_protocol
8	Downstream_session_Id
10-31	Reserved

**INA\_client\_source\_IP\_add**: the IP source address of the INA client.

**INA\_client\_destination\_IP\_add**: the IP destination address of the INA client.

**INA\_client\_source\_port**: the source port of the INA client. **INA\_client\_destination\_port**: the destination port of the INA client. **Downstream\_transport\_protocol**: the transport protocol used by the INA client (UDP/TCP). **INA\_client\_source\_MAC\_add**: a 48-bit unsigned integer that identifies the Ethernet MAC address of the INA client.

**INA\_client\_destination\_MAC\_add**: a 48-bit unsigned integer that identifies the destination Ethernet MAC address of the INA client.

**Downstream\_ethernet\_protocol**: a 16-bit field, defining the internet protocol, as described in the ethernet header.

**Downstream\_session\_Id**: a 32-bit field, describing the session\_Id, as defined for PPPoE protocol.

#### *New DS Modulation*

**New\_DS\_Modulation** is a 4-bit enumerated type indicating the modulation format for the downstream connection. {Reserved, QPSK, QAM8, QAM16, QAM32, QAM64, QAM128, QAM256, 8...15 reserved}.

#### *New DS Symbol Rate*

**New\_DS\_Symbol\_Rate** is a 32-bit unsigned integer representing the reassigned downstream symbol rate. The unit of measure is symbols/s.

#### *Connections*

**Connections** is a 8-bit unsigned integer defining the number of connection mappings defined in the message.

#### *Old Connection ID*

**Old\_Connection\_ID** is a 32-bit unsigned integer defining the connection ID being redefined.

#### *New Connection ID*

**New\_Connection\_ID** is a 32-bit unsigned integer defining the connection ID to be used on the destination INA.

*New PID*

*New\_PID* is a 16-bit unsigned integer defining MPEG program ID. Only the 13 least significant bits are valid, the three most significant bits are reserved for future use and must be zero.

*New\_DSM-CC\_MAC*

*New\_DSM-CC\_MAC* is a 6 byte field defining the MAC address that the NIU shall filter on in the DSM-CC header for the connection. Shall be ignored if set to 00:00:00:00:00:00.

*New\_DS\_VC*

*New\_DS\_VC* is a 24-bit unsigned integer defining the downstream VC. The upper 8-bit defines the ATM VPI and the lower 16-bit defines the ATM VCI.

*New\_US\_VC*

*New\_US\_VC* is a 24-bit unsigned integer defining the upstream VC. The upper 8-bit defines the ATM VPI and the lower 16-bit defines the ATM VCI.

*Maximum Contention Access Message Length*

*Maximum\_Contention\_Access\_Message\_Length* is an 8-bit number representing the maximum length of a message in ATM sized cells that may be transmitted using contention access. Any message greater than this should use reservation access. The new maximum contention access message length applies to the specified connections.

*Maximum Reservation Access Message Length*

*Maximum\_Reservation\_Access\_Message\_Length* is an 8-bit number representing the maximum length of a message in ATM sized cells that may be transmitted using a single reservation access. Any message greater than this shall be transmitted by making multiple reservation requests. The new maximum reservation access message length applies to the specified connections.

### 5.5.10.3 Channel Error Management

During periods of connection inactivity (no upstream <MAC> transmission by an NIU), the NIU shall enter an Idle Mode. Idle mode is characterized by periodic transmission by the NIU of a <MAC> **Idle Message**. The Idle Mode transmission shall occur at a periodic rate sufficient for the INA to establish Upstream Packet Error Rate statistics. The Idle Message shall be sent only when the NIU/STB has at least one connection, after the <MAC> Connect Confirm Message is received.

A detailed description of idle message transmission, including state diagrams and time outs, is given in clause A.10.

#### <MAC> Idle Message (Upstream contention or reserved)

The <MAC> **Idle Message** is sent by the NIU within the STB to the INA at predefined intervals (between 1 and 10 minutes) when the NIU is in idle mode. However, the INA may disable sending Idle Messages by sending a value of zero in the *Idle\_Interval* field contained in the <MAC> Default Configuration Message.

**Table 43: Idle Message structure**

<i>Idle_Message</i> () {	Bits	Bytes	Bit Number/ Description
<b>Idle_Sequence_Count</b>	8	1	
<b>Power_Control_Setting</b>	8	1	
}			

*Idle Sequence Count*

*Idle\_Sequence\_Count* is a 8-bit unsigned integer representing the count (modulo 256) of <MAC> IDLE MESSAGES transmitted while the NIU is Idle. It counts the number of transmitted Idle Messages since the last sign-on, thus it starts counting at 0.

### *Power Control Setting*

`Power_Control_Setting` is an 8-bit unsigned integer representing the actual power used by the NIU/STB for upstream transmission. The unit of measure is 0,5 dB $\mu$ V.

## 5.5.10.4 Link Management Messages

### **<MAC> Transmission Control Message (Singlecast or Broadcast Downstream)**

The <MAC> TRANSMISSION CONTROL MESSAGE is sent to the NIU from the INA to control several aspects of the upstream transmission. This includes stopping upstream transmission, re-enabling transmission from a NIU or group of NIUs' and rapidly changing the upstream frequency being used by a NIU or group of NIUs' (see clause 5.5.2.2). To identify a group of NIUs' for switching frequencies, the <MAC> TRANSMISSION CONTROL MESSAGE is sent in broadcast mode with the `Old_Downstream_IB_Frequency` or `Old_Downstream_OOB_Frequency` included in the message. When broadcast with the `Old_Downstream_IB_Frequency/Old_Downstream_OOB_Frequency`, the NIU shall compare its current frequency value to `Old_Downstream_IB_Frequency/Old_Downstream_OOB_Frequency`. When equal, the NIU shall switch to the new frequency specified in the message. When unequal, the NIU shall ignore the new frequency and remain on its current channel.

It is possible to give both a new downstream and a new upstream frequency in one message. In this case, every NIU takes into account only the new frequencies, for which the old frequency field matches.

A detailed description of the transmission control process, including state diagrams and time outs, is given in clause A.8.

Table 44: Transmission Control Message structure

Transmission_Control_Message(){	Bits	Bytes	Bit Number / Description
<b>Transmission_Control_Field</b>		1	
Reserved	1		7
Change_Timeouts	1		6: {no, yes}
Switch_Downstream_IB_Frequency	1		5: {no, yes}
Stop_Upstream_Transmission	1		4: {no, yes}
Start_Upstream_Transmission	1		3: {no, yes}
Old_Frequency_Included	1		2: {no, yes}
Switch_Downstream_OOB_Frequency	1		1: {no, yes}
Switch_Upstream_Frequency	1		0: {no, yes}
<i>if (Transmission_Control_Field &amp;= Switch_Upstream_Frequency &amp;&amp; Old_Frequency_Included){</i>			
<b>Old_Upstream_Frequency</b>	<b>(32)</b>	<b>(4)</b>	
<i>}</i>			
<i>if (Transmission_Control_Field &amp;= Switch_Upstream_Frequency){</i>			
<b>New_Upstream_Frequency</b>	<b>(32)</b>	<b>(4)</b>	
New_Upstream_Channel_Number	(3)	<b>(1)</b>	7...5
Reserved	(2)		4...3
Upstream_Rate	(3)		2...0: enum
MAC_Flag_Set	(5)	<b>(1)</b>	7...3
Upstream_Modulation	(3)		2...0: enum
<i>}</i>			
<i>if (Transmission_Control_Field &amp;= Switch_Downstream_OOB_Frequency &amp;&amp; Old_Frequency_Included){</i>			
<b>Old_Downstream_OOB_Frequency</b>	<b>(32)</b>	<b>(4)</b>	
<i>}</i>			
<i>if (Transmission_Control_Field &amp;= Switch_Downstream_OOB_Frequency){</i>			
<b>New_Downstream_OOB_Frequency</b>	<b>(32)</b>	<b>(4)</b>	
<b>Downstream_Type</b>	<b>(8)</b>	<b>(1)</b>	
<i>}</i>			
<i>if (Transmission_Control_Field &amp;= Switch_Downstream_IB_Frequency &amp;&amp; Old_Frequency_Included){</i>			
<b>Old_Downstream_IB_Frequency</b>	<b>(32)</b>	<b>(4)</b>	
<i>}</i>			
<i>if (Transmission_Control_Field &amp;= Switch_Downstream_IB_Frequency){</i>			
<b>New_Downstream_IB_Frequency</b>	<b>(32)</b>	<b>(4)</b>	
<i>}</i>			
<i>if (Transmission_Control_Field &amp;= Change_Timeouts){</i>			
<b>Number_of_Timeouts</b>	<b>(8)</b>	<b>(1)</b>	
<i>for (l=0; l&lt;Number_of_Timeouts;l++) {</i>			
<b>Field</b>		<b>(1)</b>	
Code	(4)		
Value	(4)		
<i>}</i>			
<i>}</i>			
<i>}</i>			

*Transmission Control Field*

`Transmission_Control_Field` specifies the control being asserted on the upstream channel:

`Change_Timeouts` is a boolean when set indicates that timeout codes and values are included in the message. These timeouts are to be taken into account by the NIU in any case, even if the parameters `Old_Upstream_Frequency`, `Old_Downstream_IB_Frequency` or `Old_Downstream_OOB_Frequency` do not match.

`Switch_Downstream_IB_Frequency` is a boolean when set indicates that a new downstream IB frequency is included in the message.

`Stop_Upstream_Transmission` is a boolean when set indicates that the NIU should enter the "stopped" state without sending a `Link_Management_Response_Message`. Whilst in the "stopped" state, the NIU ignores all downstream <MAC> messages except `Transmission_Control_Messages` and `Ranging_and_Power_Calibration_Messages`. `Transmission_Control_Messages` are processed, but no `Link_Management_Response_Messages` are sent. `Ranging_and_Power_Calibration_Messages` are processed and `Ranging_and_Power_Calibration_Response_Messages` are still sent.

`Start_Upstream_Transmission` is a boolean when set indicates that the Network Interface Unit, if it is in "stopped" state currently, should re-enter, or attempt to re-enter (in the case of having received an `Initialization_Complete_Message` containing a non-zero `Completion_Status_Field`) the "running" state by signing on and resuming transmission on its upstream channel.

`Old_Frequency_Included` is a boolean when set indicates that the Old Frequency value is included in the message and should be used to determine if a switch in frequency is necessary.

`Switch_Downstream_OOB_Frequency` is a boolean when set indicates that a new downstream OOB frequency is included in the message.

`Switch_Upstream_Frequency` is a boolean when set indicates that a new upstream frequency is included in the message. Typically, the `switch_upstream_frequency` and the `stop_upstream_transmission` are set simultaneously to allow the NIU to stop transmission and change channel. This would be followed by the <MAC> TRANSMISSION CONTROL MESSAGE with the `start_upstream_transmission` bit set.

*Old Upstream Frequency*

`Old_Upstream_Frequency` is a 32-bit unsigned integer representing the frequency that should be used by the NIU to compare with its current frequency to determine if a change in channel is required.

*New Upstream Frequency*

`New_Upstream_Frequency` is a 32-bit unsigned integer representing the reassigned upstream carrier center frequency. The unit of measure is Hertz.

`New_Upstream_Channel_Number` is a 3-bit unsigned integer which identifies the new logical channel (denoted by 'c') assigned to the NIU/STB. Refer to clause 5.3.2.1 for the use of this parameter.

`Upstream_Rate` is an 3-bit enumerated type indicating the upstream transmission grade for the upstream connection. { `Upstream_A_AQ`, `Upstream_B_BQ`, `Upstream_C_CQ`, `Upstream_D_DQ`, 4...7 reserved }

`MAC_Flag_Set` is a 5-bit field representing the first MAC Flag set assigned to the logical channel. A downstream channel contains information for each of its associated upstream channel. This information is contained within structures known as MAC Flag Sets represented by either 24-bits (denoted b0...b23) or by 3 bytes (denoted Rxa, Rxb, Rxc). This information is uniquely assigned to a given upstream channel. Refer to clauses 5.3.1.3 and 5.3.2.1 for the use of this parameter.

`Upstream_Modulation`: 3-bit field enumerated type indicating the upstream channel modulation { QPSK, 16QAM, 2...7 reserved }

*Old Downstream OOB Frequency*

`Old_Downstream_OOB_Frequency` is a 32-bit unsigned integer representing the frequency that should be used by the NIU to compare with its current frequency to determine if a change in channel is required.



*New Downstream OOB Frequency*

`New_Downstream_OOB_Frequency` is a 32-bit unsigned integer representing the reassigned downstream OOB carrier centre frequency. The unit of measure is Hertz.

`DownStream_Type` is an 8-bit enumerated type indicating the modulation format for the down stream connection. {reserved, QPSK\_1,544, QPSK\_3,088, 3...255 reserved}

*Old Downstream IB Frequency*

`Old_Downstream_IB_Frequency` is a 32-bit unsigned integer representing the frequency that should be used by the NIU to compare with its current frequency to determine if a change in channel is required.

*New Downstream IB Frequency*

`New_Downstream_IB_Frequency` is a 32-bit unsigned integer representing the reassigned downstream IB carrier centre frequency. The unit of measure is Hertz.

**Number\_of\_Timeouts**

`Number_of_Timeouts` is a 8-bit unsigned integer which identifies the number of timeout codes and values included in the message.

**Code**

`Code` is a 4-bit unsigned integer which identifies the timeout or group of timeouts (according to Table 21, Table 22 and Table 51) for which the following value is given.

**Value**

`Value` is a 4-bit unsigned integer which gives the value for the timeout or group of timeouts identified by the preceding code according to Table 21, Table 22 and Table 51 (if specified).

**<MAC> Link Management Response Message (Upstream contention or reserved)**

The <MAC> LINK MANAGEMENT RESPONSE MESSAGE is sent by the NIU to the INA to indicate the reception and the completion of processing of the previously sent Reprovision or singlecast Transmission Control Message. The <MAC> `Link_Management_Response_Message` is not sent in the following two cases:

- in response to a broadcast `Transmission_Control_Message`;
- after reception of a `Transmission_Control_Message` with Start bit set whilst in the `ERROR_STOPPED` state, see clause A.1.

The format of the message is shown in Table 45.

**Table 45: Link Management Response Message structure**

<code>Link_Management_Response_Message(){</code>	Bits	Bytes	Bit Number/Description
<code>Link_Management_Msg_Number</code>	16	2	
<code>}</code>			

*Link Management Message Number*

`Link_Management_Msg_Number` is a 16-bit unsigned integer representing the previously received Reprovision or `Transmission_Control_Message`. The valid values for `Link_Management_Msg_Number` are shown in Table 46.

**Table 46: Link Management Message Number**

Message Name	Link_Management_Msg_Number
Transmission Control Message	Transmission Control Message Type Value
Reprovision Message	Reprovision Message Type Value

**<MAC> Status Request Message (Downstream Singlecast)**

The STATUS REQUEST message is sent by the INA to the NIU to retrieve information about the NIUs' health, connection information and error states. The INA can request either the address parameters, error information, connection parameters or physical layer parameters from the NIU. The INA can only request one parameter type at a time to a particular NIU.

A detailed description of the status request process, including state diagrams and time outs, is given in clause A.9.

**Table 47: Status Request Message structure**

<b>Status_Request(){</b>	<b>Bits</b>	<b>Bytes</b>	<b>Bit Number/Description</b>
<b>Status_Control_Field</b>		<b>1</b>	
Status_Type	8		0..7:{enum type}
}			

*Status Control Field*

Status\_Type is a 8-bit enumerated type that indicates the status information the NIU should return

```
enum Status_Type {Address_Params, Error_Params, Connection_Params,
Physical_Layer_Params, reserved 4...255};
```

**<MAC> Status Response Message (Upstream contention or reserved)**

The <MAC> STATUS RESPONSE MESSAGE is sent by the NIU in response to the <MAC> STATUS REQUEST MESSAGE issued by the INA. The contents of the information provided in this message will vary depending on the request made by the INA and the state of the NIU. The message shall be dissociated into separate messages if the resulting length of the message exceeds 40 bytes, even if fragmentation of <MAC> messages is supported.

Table 48: Status Response Message Structure

Status_Response(){	Bits	Bytes	Bit Number/ Description
<b>NIU_Status</b>		<b>4</b>	
Reserved	29		31...3
Network_Address_Registered	1		2
Connection_Established	1		1
Calibration_Operation_Complete	1		0
<b>Response_Fields_Included</b>		<b>1</b>	
Reserved	4		4...7:
Address_Params_Included	1		3:{no, yes}
Error_Information_Included	1		2:{no, yes}
Connection_Params_Included	1		1:{no, yes}
Physical_Layer_Params_Included	1		0:{no, yes}
<i>if (Response_Fields_Included &amp;= Address_Params_Included){</i>			
<b>NSAP_Address</b>	<b>(160)</b>	<b>(20)</b>	
<b>MAC_Address</b>	<b>(48)</b>	<b>(6)</b>	
<i>}</i>			
<i>if (Response_Fields_Included &amp;= Error_Information_Included){</i>			
<b>Number_Error_Codes_Included</b>	<b>(8)</b>	<b>(1)</b>	
<i>for(i=0;i&lt;Number_Error_Codes_Included;   i++){</i>			
<b>Error_Param_code</b>	<b>(8)</b>	<b>(1)</b>	
<b>Error_Param_Value</b>	<b>(16)</b>	<b>(2)</b>	
<i>}</i>			
<i>}</i>			
<i>if (Response_Fields_Included &amp;= Connection_Params_Included) {</i>			
<b>Number_of_Connections</b>	<b>(8)</b>	<b>(1)</b>	
<i>for(i=0;i&lt;Number_of_Connections;i++){</i>			
<b>Connection_ID</b>	<b>(32)</b>	<b>(4)</b>	
<i>}</i>			
<i>}</i>			
<i>if (Response_Fields_Included &amp;= Physical_Layer_Params_Included) {</i>			
<b>Power_Control_Setting</b>	<b>(8)</b>	<b>(1)</b>	
<b>Reserved</b>	<b>(16)</b>	<b>(2)</b>	
<b>Time_Offset_Value</b>	<b>(16)</b>	<b>(2)</b>	
<b>Upstream_Frequency</b>	<b>(32)</b>	<b>(4)</b>	
<b>OOB_Downstream_Frequency</b>	<b>(32)</b>	<b>(4)</b>	
<b>IB_Downstream_Frequency</b>	<b>(32)</b>	<b>(4)</b>	
<b>SNR_Estimated</b>	<b>(8)</b>	<b>(1)</b>	
<b>Power_Level_Estimated</b>	<b>(8)</b>	<b>(1)</b>	
<i>}</i>			
<i>}</i>			

### NIU Status

NIU\_Status is a 32-bit unsigned integer that indicates the current state of the NIU.

NIU_Status	NIU Status Code
Calibration_Operation_Complete	0x01
Connection_Established	0x02
Network_Address_Registered (reserved)	0x04

The state Calibration\_Operation\_Complete is reached after an Initialization Complete Message with status zero. The Connection\_Established state indicates that the NIU has received a Connect Message indicating a connection which has not been released yet.

*Response Fields Included*

`Response_Fields_Included` is an 8-bit unsigned integer that indicates what parameters are contained in the upstream status response.

*NSAP Address*

`NSAP_Address` is a 20 byte address assigned to the NIU.

*MAC Address*

`MAC_Address` is a 6 byte address assigned to the NIU.

*Number of Error Codes Included*

`Number_Error_Codes_Included` is an 8-bit unsigned integer that indicates the number of error codes are contained in the response.

*Error Parameter Code*

`Error_Parameter_Code` is a 8-bit unsigned integers representing the type of error reported by the NIU. `Error_Parameter_Codes` not supported by the NIU are not sent.

**Table 49: Error Parameter Code**

<b>Error Parameter Code Name</b>	<b>Error Parameter Code</b>
Reserved for compatibility	0x00
Slot_Configuration_CRC_Error_Count	0x01
Reed_Solomon_Error_Count	0x02
ATM_Packet_Loss_Count	0x03
Slot_Configuration_Count	0x04
SL-ESF_CRC_Error_Count	0x05
Reed_Solomon_Errors_Correctable	0x06
Reed_Solomon_Errors_Non_Correctable	0x07
SL-ESF_Frame_Count	0x08

`Reserved_For_Compatibility` is reserved for compatibility with ETS 300 800 [24].

`Slot_Configuration_CRC_Error_Count` refers to the number of errors in `Slot_Configuration_Count` R bytes, as found by the CRC decoder.

`Reed_Solomon_Error_Count` refers the number of errors as corrected by the Reed\_Solomon decoder.

`ATM_Packet_Loss_Count` refers to the number of received ATM cells that were lost, either due to unrecoverable Reed-Solomon errors or because of an erroneous HEC of the ATM cells header.

`Slot_Configuration_Count` refers to the number of R-byte sets (R<sub>x</sub>a-R<sub>x</sub>c) used to calculate `Slot_Configuration_CRC_Error_Count`. This parameter is included so that NIUs can either measure only the errors in the R-byte set it is allocated to, or measure the errors in all R-byte sets.

`SL-ESF_CRC_Error_Count` refers to the number of CRC errors found in consecutive C1-C6.

`Reed_Solomon_Errors_Correctable` refers to MPEG frames received with correctable Reed Solomon Errors (IB only).

`Reed_Solomon_Errors_Non_Correctable` refers to MPEG frames received with non correctable Reed Solomon Errors (IB only).

`SL-ESF_Frame_Count` refers to the number of frames the statistics in this message apply on.

### *Error Parameter Value*

`Error_Parameter_Value` is a 16-bit unsigned integer representing error counts detected by the NIU. These values are set to 0 after they are transmitted to the INA. If the counter reaches its maximum value, it stops counting. The counter resumes counting after it is set to 0.

### *Number of Connections*

`Number_of_Connections` is an 8-bit unsigned integer that indicates the number of connections that are specified in the response. Specifically, if the number of connections is too large to have a MAC message with less than 40 bytes, it is possible to send separate messages with only the number of connections indicated in each message.

### *ConnectionID*

`Connection_ID` is a 32-bit unsigned integer representing the global connection Identifier used by the NIU for this connection.

### *Power Control Setting*

`Power_Control_Setting` is an 8-bit unsigned integer representing the actual power used by the NIU/STB for upstream transmission. The unit of measure is 0,5 dB $\mu$ V.

### *Time Offset Value*

`Time_Offset_Value` is a 16-bit short integer representing a relative offset of the upstream transmission timing (relative compared to the `Absolute_Time_Offset` given in the Default Configuration Message). A negative value indicates an adjustment forward in time. A positive value indicates an adjustment back in time. The unit of measure is 100 ns.

### *Upstream Frequency*

`Upstream_Frequency` is a 32-bit unsigned integer representing the channel assigned to the connections. The unit of measure is in Hertz.

### *Downstream Frequencies*

`OOB_Downstream_Frequency` is a 32-bit unsigned integer representing the Frequency where the connections on Out Of Band channel resides. The unit of measure is in Hertz. When not significant field, this field is set to 0.

`IB_Downstream_Frequency` is a 32-bit unsigned integer representing the Frequency where the connections on In Band channel resides. The unit of measure is in Hertz. When not significant field, this field is set to 0.

`SNR_Estimated` is an 8-bit unsigned integer specifying the NIU estimated signal to noise ratio of the downstream carrying MAC messages. The unit is dB  $\times$  2. If the NIU is not able to estimate the value, the value zero (0) is used.

`Power_Level_Estimated` is an 8-bit unsigned integer specifying the NIU estimated power level of the downstream carrying MAC messages. The unit is dB $\mu$ V  $\times$  2. If the NIU is not able to estimate the value, the value zero (0) is used.

## 5.6 Minislots

### 5.6.1 Carrying Minislots

Minislots may only be used to send <MAC> Reservation\_Request messages. Only contention access is allowed for minislots.

Minislots can be utilized in both in-band signalled and out-of-band signalled systems. The in-band signalling uses the same control fields as the out-of-band signalling inside the MAC flags, and the MAC messages are the same for both in-band and out-of-band signalling case. The phrase minislot refers to a physical frame structure of the upstream channel. The 64 byte (QPSK modulation) respectively 128 byte (16QAM modulation) upstream bursts are called upstream packets.

### 5.6.2 Minislot framing structure

In case minislots are used, the upstream slot structure is sub-divided into three (QPSK) respectively six (16QAM) 21 byte long mini-slots. Each of these minislots can be sent by different user terminals. The upstream channel can support a mixture of full slots and minislots. The format of the minislot is shown in the following Figures.

For QPSK it contains a 4 byte Unique Word (the minislot UW and the full slot UW will differ to enable simple decoding of the full slots and the minislots by the PHY), a 14 byte payload +2 bytes RS field and a single byte guard band.

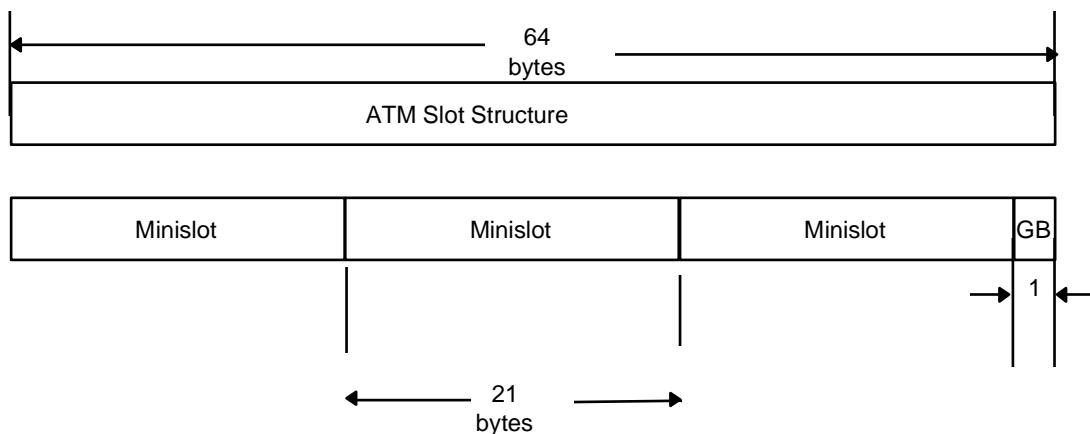

**Figure 45: Minislot Framing Structure for QPSK**

For the structure of the minislot itself see clause 5.5.2.6.

For 16QAM it contains a 8 byte Unique Word (the minislot UW and the full slot UW will differ to enable simple decoding of the full slots and the minislots by the PHY), a 9 bytes payload+2 bytes RS field, and a 2 byte guard band.

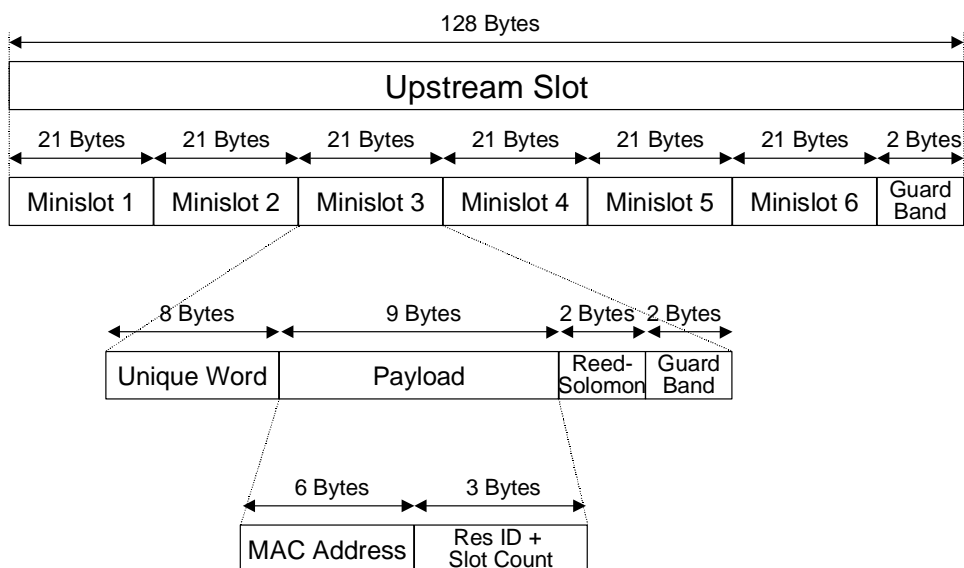

**Figure 46: Minislot Framing Structure for 16QAM**

### 5.6.3 Contention resolution for minislots

Minislots may carry the Reservation Request MAC message. The message is sent in a contention based minislot. In the case of collision, the resolution is carried out according to a INA controlled ternary splitting algorithm (see Figure 47). All necessary information is transmitted in the minislot feedback and minislot allocation sections of the Reservation\_Grant\_Message.

If Stack\_Entry is not set a NIU may enter the contention process only when the Allocation\_Collision\_Number is equal to zero. If Stack\_Entry is set, the NIU may enter the contention resolution in any of the contention based minislots, independent of the value of Allocation\_Collision\_Number. In both cases the random number for the minislot selection in the range between 0 and Entry\_Spreading shall be in the window from 0 to 2 before sending the request.

The Feedback\_Collision\_Number equals to 0xFF and 0xFE for idle and successful transmission, respectively. All other values of the Collision\_Number are numbered as collisions and used to select the retransmission minislots: the NIU shall retransmit in a minislot having an Allocation\_Collision\_Number equal to Collision\_Number

The retransmission of the collided request takes place in a minislot that is randomly selected among the group of three minislots with the corresponding Allocation\_Collision\_Number.

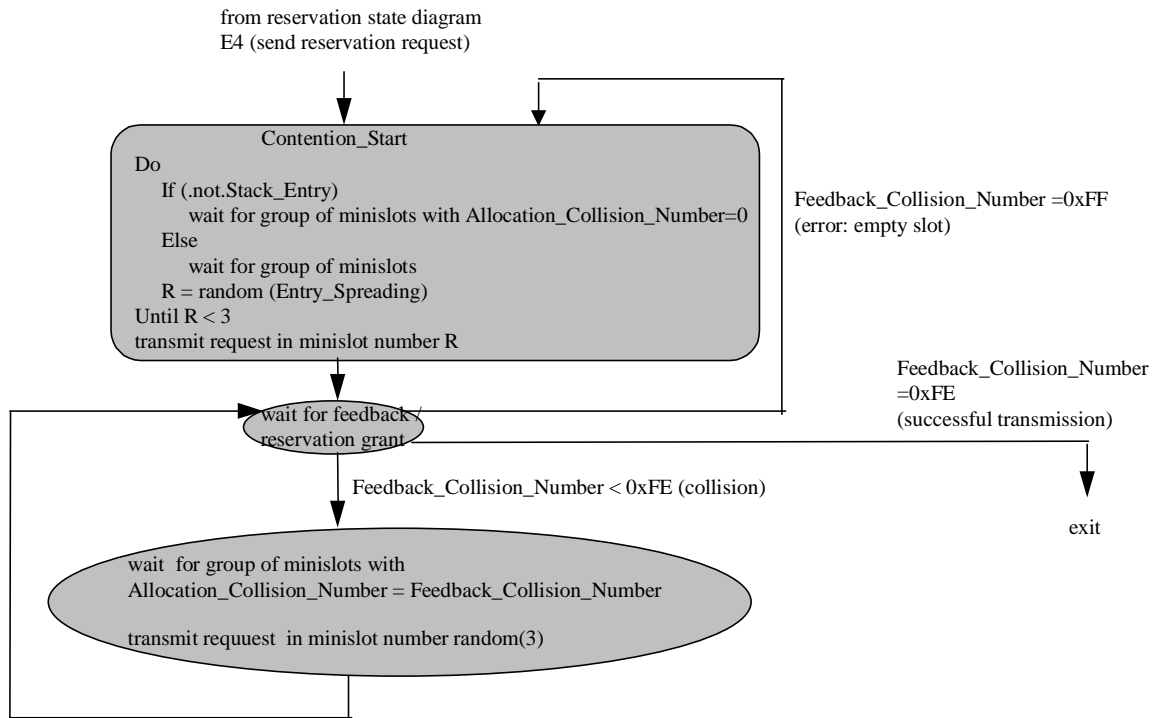

**Figure 47: Ternary Splitting Algorithm**



## 5.7 Header Suppression

The header suppression algorithm is based on the fact that for an IP session, most of the header fields are fixed. So, if we can determine in advance which fields will have a fixed value, we can save this fixed information on both sides of the link as reference. We will relate an IP packet to a session, and will only need to send the header changing fields. On the other side of the link, we will assign the packet to a session, and reconstruct the packet using the reference information.

### 5.7.1 The Suppression Scheme

Figure 48 presents the suppression scheme in the upstream direction.

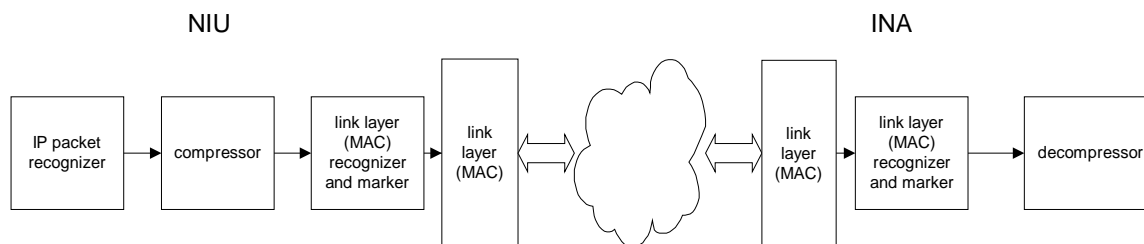

**Figure 48: Suppression Scheme**

The scheme in the downstream is identical to that in the upstream (compressor is located at the INA, decompressor at the NIU).

The suppression scheme includes two types of blocks:

- Blocks that are responsible for the suppression implementation. These are the compressor and the decompressor blocks, and their implementation is described in clause 5.7.2.
- Blocks that are intended to supply supporting services to the compressor and decompressor:
  1. IP recognizer: responsible for classifying the IP packets as either packets that should be suppressed or other IP packets.
  2. Link layer recognizer and marker: this block will be responsible for classifying the decompressor input packets. It should identify the suppressed packets, according to the suppression header.
  3. MAC

The MAC should guaranty the following functions:

- Negotiate the suppression direction (upstream/downstream/upstream and down stream) and mask (see clause 5.7.3).
- Deliver the value of the suppressed fields. Packets (suppressed or not) will be sent through the appropriate connection.

### 5.7.2 Suppression Algorithm

The scheme abides by the following guidelines:

- A session is defined according to the IP source/destination addresses, and the source/destination port. Every session is identified by a context ID.
- A suppression mask is used for defining the fixed fields. Since the fixed fields change according to the protocols used with the IP layer, the mask will change according to the application.

The mask is interpreted according to the following rules:

- The mask is always 103-bits long.

- A bit in the mask acts as a flag for a header byte: if the mask bit is 0, the header matching byte is fixed, and should be suppressed.
- The bit/byte matching is according to the sending order.
- For DVB encapsulations, the matching will be as follows:
  - Direct IP encapsulation: the mask MSB matches the first IP header byte.
  - Ethernet MAC Bridging: the mask MSB matches the first LLC/SNAP header byte.
- Every set of fixed fields value, has a generation number. If the value of fixed fields changes, the generation number also changes.

The suppression is performed in the following manner:

- Before sending suppressed packets, the suppressing entity (INA/NIU) **MUST** send a <MAC> suppression data message. The message defines if suppression is performed in this direction, and what is the suppression mask. The message also contains the value of the fixed fields that are being suppressed, the session context ID, and the generation number associated with the fixed fields value.
- After sending the message, the suppressing entity can start sending suppressed packets. When a suppressed packet is received at the decompressor, it is identified and associated to a session according to the suppression header (using the context ID number). The decompressor checks that the packet generation number equals the saved fixed fields' generation number (as sent by the <MAC> message). If the generation numbers are not equal - the fixed fields value known to the decompressor is not updated, and the packet cannot be reconstructed. If the numbers are equal, the fixed fields are added to the packet, and the packet is reconstructed.
- The decompressing entity **MUST** send a <MAC> suppression acknowledgment message within  $T_{ack} = 100$  ms. The message acknowledges the receiving entity ability to reconstruct the suppressed packets.
- If a <MAC> suppression acknowledgment message was not received within  $T_{ack}$ , the suppressing entity **MUST** send another <MAC> suppression data message.
- If a <MAC> suppression acknowledgment message was not sent after  $T_{fail} = 1$  s period, the suppressing entity **MUST** stop sending suppressed packets. The data **SHOULD** be sent through a different connection.

### 5.7.3 Negotiation of the Suppression Scheme

There are three options for suppression scheme: upstream suppression, downstream suppression, and full duplex (upstream and downstream) suppression. For every direction (upstream/downstream), the decision whether to suppress or not and according to what mask, is negotiated independently. The INA and the NIU negotiate through the <MAC> suppression data and <MAC> suppression acknowledgment messages.

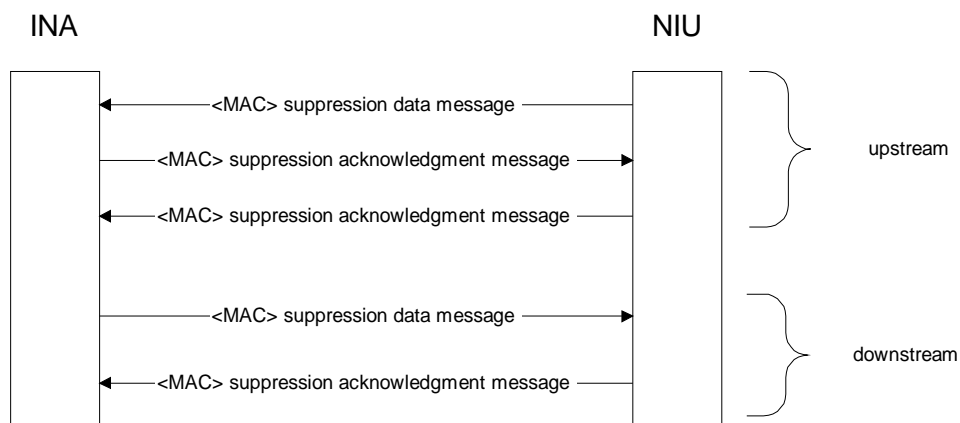
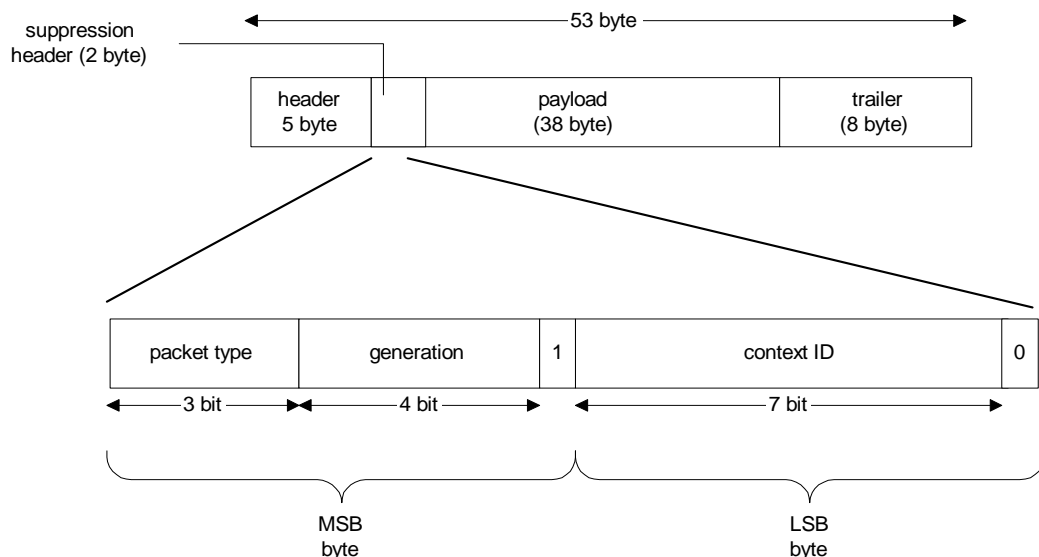

Figure 49: Suppression Negotiation

- **Upstream:**  
The NIU sends a proposed mask and set the suppression flag to true through the <MAC> suppression data message. The INA either accept (sends the same mask and flag) or sends a subset suggestion (either with a new mask and the suppression flag set to true, or the same mask and the suppression flag set to false) through the <MAC> suppression acknowledgment message.  
If the INA changes the mask, the NIU can reply with another <MAC> suppression acknowledgment message, with the suppression flag set to false.
- **Downstream:**  
The INA sends a proposed mask and set the suppression flag to true. The NIU either accept (sends the same mask and flag) or refuse the suppression by sending a <MAC> suppression acknowledgment message with the suppression flag set to false.
- **Full duplex:**  
In full duplex suppression **both** downstream and upstream scenarios **MUST** be performed: the negotiation and initialization of suppression in the upstream is independent of the negotiation and initialization of the suppression in the downstream. The INA will send <MAC> suppression data message for the downstream direction, and will receive a <MAC> suppression data message for the upstream direction. The NIU will send <MAC> suppression data message for the upstream direction, and will receive a <MAC> suppression data message for the downstream direction.

## 5.7.4 Suppression Header



**Figure 50: Suppression Header**

The suppression header will be added to all suppressed packets. Figure 50 describes the structure of an ATM cell that carries a suppressed packet. The suppression header is located right after the ATM header.

For Ethernet MAC bridging: the suppression for US, and OOB DS is done during ALL5 encapsulation - after adding the LLC/SNAP header and before the trailer is added. The suppression for IB DS is done during DSM-CC encapsulation: after adding the LLC/SNAP header and before CRC is added.

The header consist of three fields:

**Packet type:** 3 bit. Define the packet as created by the compressor.

Packet type	Value
Suppressed packet	0
Reserved	1
Not to be used	2-7

**Generation:** 4 bit. The session current generation number (see clause 5.7.1).

**Context ID:** 7 bit. An identifier for the session (see clause 5.7.1).

## 5.7.5 Header Suppression <MAC> Messages

### 5.7.5.1 <MAC> Suppression Data Message

The message is sent by the suppression initiator. It is used for negotiating the suppression mask and scheme, and for passing the fixed fields value. In case of upstream suppression, the NIU sends the message to the INA. In case of downstream suppression, the INA sends a single cast message to the relevant NIU.

If needed, the message should be fragmented.

Suppression_Data_Message(){	Bits	Bytes	Bit Number / Description
<b>Connection ID</b>	<b>32</b>	<b>4</b>	
<b>Context ID</b>	<b>8</b>	<b>1</b>	LSB bit is ignored
<b>Suppression control field</b>	<b>8</b>	<b>1</b>	
Reserved	5		Must be set to 0
direction	1		2:{US,DS}
Suppression_scheme_included	1		1: {no, yes}
Header_fields_included	1		0: {no, yes}
<i>if (suppression_control_field&amp;=suppression_sche_included){</i>			
<b>Suppression scheme</b>	<b>1</b>	<b>13</b>	
Suppression mask	103		
Suppression flag	1		103: {no, yes}
<i>}</i>			
<i>if (suppression_control_field &amp;=header_field_included){</i>			
<b>Generation number</b>	<b>8</b>	<b>1</b>	4 MSB bits are ignored
<b>Header length</b>	<b>8</b>	<b>1</b>	
<b>Header fields</b>			Up to 103 bytes
<i>}</i>			

**Connection ID:** 4 byte field, the connection ID that suppressed packets are sent through.

**Context ID:** 7-bit field. context ID is an identifier for the session (see clause 5.7.2). the suppression scheme header fields and generation number relates to suppressed packets that are sent through the connection ID and has that context ID in the suppression header.

**Suppression control field:** 8-bit control field.

Direction: if set to US, the message establishes suppression in the US. If set to DS, the message establishes suppression in the DS.

Suppression\_mask\_included: a Boolean, indicating whether the message includes a suppression mask and flag.

Header\_field\_included: a Boolean, indicating whether the message includes a value for the fixed fields.

**Suppression scheme:** 13 byte field.

Suppression mask: 103 bits, indicating what bytes of the header fields are suppressed. If the mask bit is 0, the matching header byte is suppressed (see clause 5.7.2).

Suppression flag: a Boolean. If set to true a suppression is performed.

**Generation number:** The generation number that is attached to the header fields value.

**Header length:** The number of bytes in the full header (the number of bytes that are sent in the **header fields** field).

**Header fields:** The full header of the packets (fixed and changing fields together). The field length changes according to the packet suppressed, but is limited in 103 bytes.

### 5.7.5.2 <MAC> Suppression Acknowledgment Message

This message acknowledges the receiving of a <MAC> suppression data message and for negotiating the suppression mask and scheme. If the message is sent by the INA, it is a single cast message.

Suppression_Acknowledgment_Message(){	Bits	Bytes	Bit Number/Description
<b>Connection ID</b>	<b>32</b>	<b>4</b>	
<b>Context ID</b>	<b>8</b>	<b>1</b>	LSB bit is ignored
<b>Suppression control field</b>	<b>8</b>	<b>1</b>	
Reserved	6		
Direction	1		2: {US, DS}
Suppression_scheme_included	1		1: {no, yes}
Header_ack_included	1		0: {no, yes}
<i>if (suppression_control_field&amp;=suppression_sche_included){</i>			
<b>Suppression scheme</b>	<b>1</b>	<b>13</b>	
Suppression mask	103		
Suppression flag	1		103: {no, yes}
<i>}</i>			
<i>if (suppression_control_field &amp;=header_field_included){</i>			
<b>Generation number</b>	<b>8</b>	<b>1</b>	4 MSB bits are ignored
<i>}</i>			

**Connection ID:** 4 byte field, the connection ID that suppressed packets are sent through.

**Context ID:** 7-bit field. Context ID is an identifier for the session (see clause 5.7.2). The suppression scheme header fields and generation number relates to suppressed packets that are sent through the connection ID and has that context ID in the suppression header.

**Suppression control field:** 8-bit control field.

Direction: if set to DS, the message acknowledges suppression in the DS. If set to US, the message acknowledge suppression in the US, .Suppression\_mask\_included: a Boolean, indicating whether the message includes a suppression mask and flag.

**Suppression scheme:** 13 byte field.

**Suppression mask:** 103-bits, indicating what bytes of the header fields are suppressed. If the mask bit is 0, the matching header byte is suppressed (see clause 5.7.2).Suppression flag: a Boolean. If set to true a suppression is performed.

**Generation number:** The generation number that is attached to the header fields' value.

### 5.7.6 Suppression of RTP sessions

Data packets that are carried by RTP protocols, contains the combination of RTP/UDP/IP headers.

Figure 51 describes the fixed fields for the packets.

Figure 52 describes the suppression mask for RTP sessions.

Figure 53 describes the format of a suppressed packet (without a suppression header).

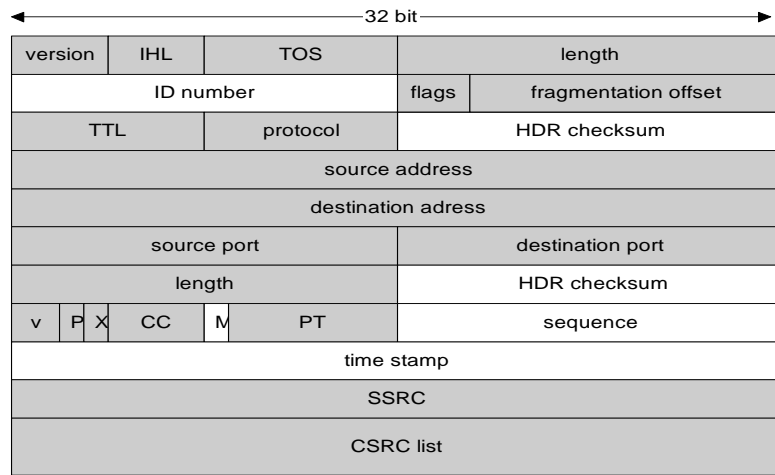

Figure 51: Fixed Fields for RTP/UDP/IP

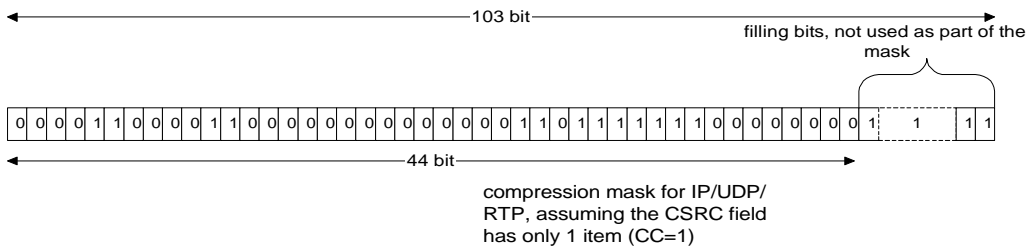

Figure 52: Suppression Mask for RTP/UDP/IP

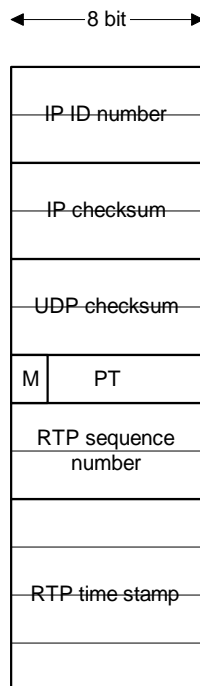

Figure 53: RTP/UDP/IP Header with Suppressed Fields

## 5.8 Security (optional)

The security solution consists of two separate sub-systems:

- a new set of MAC messages used for authentication and key-agreement between INA and NIU. These messages are used for key negotiation during connection setup as well as for on-the-fly update of keys (see clause 5.8.7);
- on-the-fly encryption and decryption of payload data streams passed between INA and NIU.

When a connection is being setup, before payload data is transferred, one of three new request/response MAC message-pairs is used to generate a session key specific to the payload stream associated with the connection.

The session key is a shared secret between the INA and the NIU: even if every MAC message is intercepted, the cryptographic properties of the protocol ensure that an eavesdropper cannot determine the session key value.

This is achieved by using a public-key protocol, which requires no up-front shared secret, or a simpler protocol based on a long-term shared secret between INA and NIU called a cookie. The cookie is 160-bits long. It is also used for authenticating the NIU to the INA during connection-setup.

Each NIU will store its own cookie in non-volatile storage, whereas the INA will maintain a data-base of the cookie values of the NIUs on its network. Cookie values will be updated occasionally as dictated by security policy, but they are less vulnerable than session keys: a successful brute-force attack on a session key reveals nothing about the cookie value, nor any other session key.

The new MAC messages also implement a defence against clones: a NIUs that is a physical copy of an existing NIU and attempts to operate on the network under the cloned identity (when the cloned NIU itself is not registered on the network). The anti-cloning measure is a simple non-volatile 8-bit counter that is incremented synchronously at the INA and NIU over time: if a clone NIU engages in traffic with the INA, this will be detected the next time the cloned NIU connects because the counter value will be out of synchronization.

If the clone attempts to operate concurrently with the cloned unit, there will be an immediate break-down of functionality for both units, due to confusion within the MAC protocol. This amounts to a denial-of-service attack, and the INA should be prepared for this kind of protocol failure.

Used mathematical operators and symbols in this clause:

×	multiplication
^	lower
~	concatenation
mod	modulo division
(unsigned char)x	NSI C cast operator: converts value x to unsigned char
""	empty string (zero length)
nonce1	random string (INA)
nonce2	random string (NIU)

### 5.8.1 Cryptographic primitives

The key exchange protocols and data stream encryption is based on a set of well-established primitive cryptographic functions. The functions and their associated key sizes can be changed in the future, in case crypt-analytic or brute-force attacks become a realistic threat.

The specific set of functions and key sizes are negotiated between INA and NIU at sign-on time. The functions supported at the present time are Diffie-Hellman, HMAC-SHA1, and DES. Check current cryptographic literature for any updates regarding their security and use.

The following clauses give a brief overview of the cryptographic primitives, and details on how they are used in the protocol. Later clauses describe the exact field layout of the new MAC messages.

The protocol parameters are described in terms of byte strings, where concatenation is denoted by the ~ operator. Integer quantities are represented as base-256 byte strings. Big-endian byte-ordering is used, that is, the most significant byte comes first. If necessary to reach a fixed length, the string is padded with zeros at the most significant end.

### 5.8.1.1 Public key exchange

A public key exchange primitive is used to allow the INA and NIU to agree on a secret, although communicating in public. The Diffie-Hellman scheme is based on unsigned integer arithmetic and works as follows (^ denotes exponentiation):

The INA chooses two public values, a large prime number **m**, and a (small) number **g** which is a generator modulo **m** (**that is,  $g^a \bmod m$  will generate all number from 0 to  $m-1$  for varying  $a$** ). The INA also chooses a secret number **x** < **m**, and sends the following three values to the NIU: **m**, **g**, **X** =  $g^x \bmod m$ .

The NIU chooses a secret value **y** < **m**, and responds to the INA with the value **Y** =  $g^y \bmod m$ .

The NIU now calculates  $s = X^y \bmod m = (g^x)^y \bmod m = g^{(x \times y)} \bmod m$ , whereas the INA calculates  $Y^x \bmod m = (g^y)^x \bmod m = g^{(y \times x)} = s$ , so the INA and NIU now agree on the value **s**.

The value of **s** is a secret shared between INA and NIU. To determine its value from the publicly communicated values **m**, **g**, **X**, and **Y**, an eavesdropper shall determine **x** or **y** by solving an equation of the form  $Z = g^z \bmod m$  for unknown **z**. This is known as the discreet logarithm problem and is computationally infeasible with current algorithms for sufficiently large values of **m**.

The parameter size supported are 512-bits for the prime number **m**, and hence also for the remaining values since all arithmetic is modulo **m**.

In the applicable MAC messages, the unsigned integer quantities **m**, **g**, **X**, and **Y** are encoded into fixed-size fields (64, 96, or 128 bytes) using big-endian byte-ordering.

### 5.8.1.2 Hashing

The protocol makes use of a keyed hash function that computes secure checksums which can only be verified with the possession of a secret key. The function has the one-way property, meaning that it is computationally infeasible to find an input value that maps to a given output value.

The hash function is also used to generate derived secret material based on a master secret. Because of the one-way property, the master secret is protected even if the derived secret is discovered.

In generic terms, the keyed hash function takes two byte strings as input, the key and a data string, and produces another string of bytes, the **digest**:

$$\text{digest} = H(\text{key}, \text{data})$$

The H function shall accept key and data parameters of any size, whereas the protocol is designed to accept digests of any size.

The specification currently supports the HMAC-SHA1 function defined in IETF RFC 2104 [5]. It produces a 20-byte digest.

### 5.8.1.3 Encryption

Payload data is encrypted and decrypted using a symmetric-key block cipher, which is used in Cipher Block Chaining (CBC) mode with special handling of any final odd-size block.

In generic terms, the encryption and decryption functions take two byte strings as input, the key and a data block, and produce as output another data block of the same length:

$$\text{ciphertext} = E(\text{key}, \text{plaintext})$$

$$D(\text{key}, \text{ciphertext}) = \text{plaintext}$$



The key length and block length is given by the chosen cipher, and the payload stream processing logic will apply it as appropriate to data units of various sizes.

The specification currently supports the DES algorithm, which has a block size is 8 bytes, and various options for key length based on an 8-byte raw key block (see clause 5.8.5).

#### 5.8.1.4 Pseudo-random numbers

The protocols used for generating secret values depend on the availability of a pseudo-random, that is, practically unpredictable, endless string of bytes. This will typically be produced with a Pseudo-Random Number Generator, PRNG, algorithm.

The random bytes are used to generate the secret Diffie-Hellman values,  $x$  and  $y$ , and for nonce values used during key exchange. The unpredictable nature of the random input ensures that different secret values are produced each time, and also prevents replay of old intercepted messages.

This specification does not require any particular algorithm, only that the INA and NIU each choose one that is well-established and cryptographically analysed.

The hardest aspect of using a PRNG is to initialize it with an unpredictable seed value. The seed should contain multiple high-granularity device-dependent time-samples, samplings of cable line noise, as well as any other available pseudo-random material, like file allocation Tables, etc. These random source values are then hashed together to squeeze out the entropy for the seed value.

### 5.8.2 Main Key Exchange, MKE

Main Key Exchange uses Diffie-Hellman to develop a shared secret between the INA and NIU, which is independent of the cookie value. Furthermore, it uses the cookie value to authenticate the NIU to the INA. It optionally uses the newly developed shared secret to update the cookie value. Finally, it derives a shared secret key used for the security context that is used to process payload stream data.

The exchange is initiated by the INA sending a message containing the Diffie-Hellman values,  $m$ ,  $g$ ,  $X$ , and a random nonce string, **nonce1**. The NIU responds with a message containing its Diffie-Hellman value,  $Y$ , a random nonce string, **nonce2**, and an authentication string, **auth**.

The INA and NIU each use the same formula to calculate the authentication string (~ means concatenation):

$$\mathbf{auth} = \mathbf{H} ( \mathbf{cookie}, \mathbf{nonce1} \sim \mathbf{nonce2} )$$

which is communicated by the NIU and checked by the INA. This proves the identity of the NIU, since it requires knowledge of the cookie to calculate the correct value of **auth**.

The NIU and INA each use the Diffie-Hellman values (see clause 5.8.1.1) to arrive at the same secret value,  $s$ :

$$s = g^{(x \times y)} \bmod m.$$

This unsigned integer value is encoded as a byte string, of length specified by the Diffie-Hellman parameter size, using big-endian byte ordering. It is then used to calculate a temporary shared secret string, **temp**:

$$\mathbf{temp} = \mathbf{H} ( \mathbf{encode} ( s ), \mathbf{nonce2} \sim \mathbf{nonce1} ).$$

If the cookie is to be updated, the new value is computed in sections for  $n = 1, 2, \dots$ :

$$\mathbf{newcookie}(n) = \mathbf{H} ( \mathbf{temp} \sim (\mathbf{unsigned\ char})1 \sim (\mathbf{unsigned\ char})n, "" )$$

where (unsigned char) is the cast operator of the C programming language, and "" is the empty string (zero length). These string values are computed and concatenated until the total length matches or exceeds the length of the cookie. The cookie is then obtained by taking the first 20 bytes out of the concatenated sections, starting from the beginning.

The session key used for payload stream encryption is likewise computed in sections:

$$\mathbf{key}(n) = \mathbf{H} ( \mathbf{temp} \sim (\mathbf{unsigned\ char}) 2 \sim (\mathbf{unsigned\ char}) n, "" )$$

where, again, a sufficient number of sections are calculated to produce enough bytes to cover the length of the key. The session key is obtained „in the same manner as the cookie" by taking the required number of bytes out of the concatenated sections, starting from the beginning.

### 5.8.3 Quick Key Exchange, QKE

Quick Key Exchange uses the existing cookie value to authenticate the NIU to the INA, and then derive a shared secret key used for the security context that is used to process payload stream data.

The exchange is initiated by the INA sending a message containing a random nonce string, **nonce1**. The NIU responds with a message containing a random nonce string, **nonce2**, and an authentication value, **auth**.

The value of **auth** is calculated in the same way as for Main Key Exchange, and is likewise used to verify the identity of the NIU (see clause 5.8.2).

The NIU and INA then each calculate a temporary shared secret string, **temp**:

$$\mathbf{temp} = \mathbf{H}(\mathbf{cookie} \sim (\mathbf{unsigned\ char})^3, \mathbf{nonce2} \sim \mathbf{nonce1})$$

This value is used to produce the payload encryption key in the same way as for Main Key Exchange (see clause 5.8.2).

### 5.8.4 Explicit Key Exchange, EKE

Explicit Key Exchange is used by the INA to deliver a pre-determined session key to the NIU. The session key is encrypted under a temporary key derived from the cookie value, and is used for the security context that is used to process payload stream data.

The delivery is performed by the INA sending a message containing a random nonce string, **nonce1**, and a byte string value, **encrypted key**, which has the same length as a key used for payload encryption. The NIU responds with a message containing a random nonce string, **nonce2**, and an authentication value, **auth**.

The value of **auth** is calculated in the same way as for Main Key Exchange, and is likewise used to verify the identity of the NIU (see clause 5.8.2).

Both the INA and NIU calculate a temporary shared secret string, **temp**:

$$\mathbf{temp} = \mathbf{H}(\mathbf{cookie} \sim (\mathbf{unsigned\ char})^4, \mathbf{nonce1})$$

which is used to produce sections of a temporary key, in the same way as for Main Key Exchange (see clause 5.8.2). The INA uses these temporary **key** string sections to XOR with the session key to obtain the **encrypted key** value, and the NIU performs a second XOR operation to decrypt the session key value.

For normal DES, 8 bytes of raw key data are delivered, which are used to derive the actual key with the appropriate number of effective bits, as described below (see clause 5.8.5).

### 5.8.5 Key derivation

The actual key value used for processing payload data is derived from the **key** sections developed during key exchange. For DES, 8 bytes of raw key data is required, so a single 20-byte section, **key(1)**, computed by HMAC-SHA1 is sufficient.

In each byte, the least significant bit is not used (it can be used as an odd-parity bit of the remaining 7-bits), bringing the effective key size down to 56-bits.

Furthermore, when used in 40-bit mode, the two most significant bits of each byte in the key are zeroed.

### 5.8.6 Data stream processing

Security can be applied to various payload data streams selectively. The elementary unit is called a security context, which contains two session keys used for encrypting and decrypting a stream of payload data. Only one of the keys is used to process any particular payload unit. Each key can be used for processing both upstream and downstream payload data.

Having two keys allows negotiation of a new key to take place while payload data is processed using the old one, and then do an immediate switch-over once the new key is agreed upon, without interrupting payload traffic. The INA initiates the key exchanges, and can start using a session key for downstream traffic encryption once the key exchange is complete. For upstream traffic encryption, the NIU should use whichever key was used by the INA in the most recent encrypted payload unit.

### 5.8.6.1 Payload streams

A payload stream is identified by either of:

- a 24-bit (UNI) ATM virtual circuit VPI/VCI: this is used for ATM-based IB downstream, OOB downstream, and upstream payload data. The ATM circuit can be one-to-one, or one end-point of a multi-cast circuit;
- a 48-bit MAC-address: this is used for DVB Multiprotocol Encapsulation downstream payload data. The MAC-address can be the physical address of the STB or a pseudo address used for MAC-address based multi-casting.

When a payload stream is secured, the NIU and the INA will have matching security contexts, which are used to encrypt/decrypt both upstream and downstream traffic. For unsecured payload streams there is no security context, and payload data is not encrypted.

To support encrypted multi-cast traffic, the same security context will be created for each member using EKE (see clause 5.8.4), so that each NIU can decrypt the common payload data stream.

### 5.8.6.2 Data encryption

Within a payload data stream, data is carried in individual units at the various protocol layers. Encryption is applied at the lowest layer possible, consistent with the payload stream:

- ATM-based payload streams: the unit of encryption is a single ATM cell. The 48-byte cell payload is encrypted using the security context implied by the associated connection.
- Encryption is transparent to higher-level protocol layers, which see only unencrypted cell payloads.
- DVB Multiprotocol Encapsulation payload streams: the unit of encryption is a single DVB Multiprotocol Encapsulation section. The datagram\_data\_bytes (between the MAC-address and the CRC/checksum) are encrypted using the security context implied by the associated connection. The DVB Multiprotocol Encapsulation payload to be encrypted will be adjusted to have a length of  $n \times 8$  bytes ( $n$  is an integer) by adding an appropriate amount (0 ... 7 bytes) of stuffing bytes before the CRC/checksum according to [6]. The CRC/checksum is calculated on the encrypted datagram bytes, while higher-level protocol layers see only unencrypted datagrams.

### 5.8.6.3 Encryption flags

There are flags in the header of each encryption unit specifying which of the two sessions keys of the security context is used.

The receiver will use the security context of the payload stream to see if decryption shall be done.

- ATM cells: the least significant two bits of the Generic Flow Control, GFC, field of the cell header are used:
  - 00: not encrypted
  - 01: reserved
  - 10: encrypted using session key 0
  - 11: encrypted using session key 1

The most significant two bits of the GFC field are reserved for future use, and shall be set to 00.

- DVB Multiprotocol Encapsulation sections, according to EN 301 192 [6]: the 2-bit payload\_scrambling\_control field in the section header is used:
  - 00: not encrypted
  - 01: reserved
  - 10: encrypted using session key 0
  - 11: encrypted using session key 1

The 2-bit address\_scrambling\_control field in the section header is 00 all the time (the address is not scrambled).

#### 5.8.6.4 Chaining and initialization vector

Within encryption units, the block encryption algorithm is used in Cipher Block Chaining mode, CBC: the first plain-text block is XOR'ed with an initialization vector (IV), and subsequent blocks are XOR'ed with the previous cipher-text block, before the block is encrypted. Decryption is opposite: each cipher-text block is first decrypted and then XOR'ed with the previous chaining value.

The value of the IV for a given encryption unit is zero.

#### 5.8.7 Security Establishment

Security issues are handled in the following situations:

- When a NIU registers on the network it will do an initial handshake with the INA to establish the level of security support, in particular the cryptographic algorithms and key sizes to be used subsequently.

The handshake consists of <MAC>**Security Sign-On** and <MAC>**Security Sign-On Response** messages (see clauses 5.8.9.1 and 5.8.9.2) which are exchanged immediately prior to the <MAC>**Initialization Complete** message.

A failure during this stage of the protocol causes the INA to revert to non-secure interaction with the NIU.

- The security context of a secured payload stream is established when the underlying MAC connection is created, before any stream data is transmitted. One session key is agreed, and the cookie and/or clone counter values may be updated as part of the exchange.

The key exchange consists of <MAC>**Main/Quick/Explicit Key Exchange** and <MAC>**Main/Quick/Explicit Key Exchange Response** messages (see clauses 5.8.9.3 to 5.8.9.8) which are exchanged immediately prior to the <MAC>**Connect Confirm** message.

A failure during this stage of the protocol causes the connection-setup operation to fail.

- After a connection is in use, each session key of the security context of the payload stream can be updated on-the-fly, that is, without re-establishing the underlying connection, and without interrupting payload data traffic. The cookie and/or clone counter values cannot be updated as part of the exchange.

A new session key is negotiated using the same MAC messages used during connection-setup. There is no <MAC>**Connect Confirm** message.

A failure during this stage of the protocol causes the connection to be dropped.

While a session key of the security context is being updated for a particular connection, payload stream data traffic should be encrypted using the other session key or not at all. Once the key exchange is complete, the INA can start using it for subsequent downstream traffic, thereby directing the NIU to use it for upstream traffic.

All three variants of key exchange messages authenticate the NIU based on the existing cookie value. They also perform the clone detection counter check, and optionally increment the clone counter. Only MKE can update the cookie.

The security MAC message flow is naturally serialized within the context of the particular connection that is being setup. But, in as far as multiple connections are being established concurrently, there can also be multiple concurrent key exchanges whose messages are interleaved. The NIU is free to complete outstanding key exchanges on separate connections in any order it chooses.

## 5.8.8 Persistent state variables

To facilitate authentication, key exchange, and clone detection, the NIU has a set of state variables whose values are retained across registrations and power cycles:

**Table 50: Persistent NIU variables**

Name	Function	Size
Cookie	authentication cookie	160 bits
Cookie_SN	cookie sequence number	1 bit
Clone_Counter	clone detection counter	8 bits
Clone_Counter_SN	clone counter sequence number	1 bit

The sequence numbers are used to ensure that the INA and NIU can stay synchronized even in case the NIU drops off the net in the middle of a protocol exchange.

### 5.8.8.1 Guaranteed delivery

Within the setup protocol for a MAC connection, the INA will ensure that a protocol exchange is complete before proceeding. If it does not receive a response MAC message within a given time-interval, it will re-transmit the original message unchanged. The NIU will do likewise in situations where it requires a response. If the number of re-transmissions exceeds three, the protocol fails.

Due to race conditions, superfluous re-transmissions may be generated by both INA and NIU. They shall discard such messages after the first message has in fact been received.

If the NIU is not ready to respond within the specified time out, it can send <MAC>Wait messages (see clause 5.8.9.9) to extend the time it has available to generate a proper response. Upon receiving the wait message, the INA will restart its timer and reset the retry count.

The protocol time-out values can be set by the <MAC> Default Configuration Message, otherwise the following default values apply.

**Table 51: Protocol time-out values**

Code	Protocol stage	Default Value
0xD	Security Sign-On	90
0xE	Main Key Exchange	600
0xF	Quick Key Exchange Explicit Key Exchange	300
NOTE: The Unit for the timeouts is millisecond (ms).		

## 5.8.9 Security MAC Messages

### 5.8.9.1 <MAC>Security Sign-On (Single-cast Downstream)

As part of the registration process when a NIU attaches to the network, the INA and NIU will negotiate the specific set of cryptographic algorithms and parameters used in the key exchange protocols and for payload encryption.

The selections are global, and apply to all subsequent security exchanges for as long as the NIU is registered on the network.

The selections affect the layout of the subsequent key exchange messages, since they have fields that vary in size according to the choice of algorithms and parameters.

The INA indicates which algorithms and parameters it supports by setting the appropriate bits in the <MAC>Security Sign-On message. There are four classes of algorithms, and the INA will set one or more bits in each of the four fields to indicate which specific choices it supports.

**Table 52: Security Sign-On message structure**

Security_Sign-On (){	Bits	Bytes	Bit Number/Description	Parameter bytes
<b>Public_Key_Alg</b> PKA_Reserved PKA_DH_512	7 1	1	<b>Public key algorithm choices:</b> 7...1: Reserved, shall be 0 0:(yes/no) Diffie-Hellman, 512 bits	P <sub>pka</sub> : 64
<b>Hash_Alg</b> HA_Reserved HA_HMACSHA1	7 1	1	<b>Hash algorithm choices:</b> 7...1: Reserved, shall be 0 0:(yes/no) HMAC-SHA1	P <sub>ha</sub> : 20
<b>Encryption_Alg</b> EA_Reserved EA_DES_56 EA_DES_40	6 1 1	1	<b>Encryption algorithm choices:</b> 7...2: Reserved, shall be 0 1:(yes/no) DES, 56 bit key 0:(yes/no) DES, 40 bit key	P <sub>ea</sub> : 8  8
<b>Nonce_Size</b> NS_Reserved NS_64	7 1	1	<b>Nonce size choices:</b> 7...1: Reserved, shall be 0 0: (yes/no) 8 random bytes	P <sub>ns</sub> : 8
<b>Reserved</b>	<b>32</b>	<b>4</b>	<b>Reserved for future use, shall be 0</b>	
}				

If the security option is supported, the minimum subset to support is PKA\_DH\_512, HA\_HMACSHA1, EA\_DES\_40, and NS\_64.

EA\_DES\_56 is optional.

### 5.8.9.2 <MAC>Security Sign-On Response (Upstream)

In its security sign-on response, the NIU indicates which specific algorithms and parameters to use. It does so by choosing one of the suggestions offered by the INA within each of the four classes.

The fields of the response message have the same definition as the message from the INA, except that exactly one bit will be set in each field.

If the NIU is unable to support any of the suggested algorithms for any class, it shall return an all-zero field value, and the INA will revert to non-secure communication or re-issue the <MAC>Security Sign-On message with different choices.

Table 53: Security Sign-On Response message structure

Security Sign-On_Response() {	Bits	Bytes	Bit Number/Description	Parameter bytes
<b>Public_Key_Algo</b> PKA_Reserved PKA_DH_512	7 1	<b>1</b>	<b>Public key algorithm choices:</b> 7...1: Reserved, shall be 0 0:(yes/no) Diffie-Hellman, 512 bits	P <sub>pka</sub> : 64
<b>Hash_Algo</b> HA_Reserved HA_HMACSHA1	7 1	<b>1</b>	<b>Hash algorithm choices:</b> 7...1: Reserved, shall be 0 0:(yes/no) HMAC-SHA1	P <sub>ha</sub> : 20
<b>Encryption_Algo</b> EA_Reserved EA_DES_56 EA_DES_40	6 1 1	<b>1</b>	<b>Encryption algorithm choices:</b> 7...2: Reserved, shall be 0 1:(yes/no) DES, 56 bit key 0:(yes/no) DES, 40 bit key	P <sub>ea</sub> : 8  8
<b>Nonce_Size</b> NS_Reserved NS_64	7 1	<b>1</b>	<b>Nonce size choices:</b> 7...1: Reserved, shall be 0 0: (yes/no) 8 random bytes	P <sub>ns</sub> : 8
<b>Reserved</b>	<b>32</b>	<b>4</b>	<b>Reserved for future use, shall be 0</b>	
}				

### 5.8.9.3 <MAC>Main Key Exchange (Single-cast Downstream)

The Main Key Exchange message is used to start a cookie-independent key exchange with the NIU, and also instructs the NIU whether to update its cookie value and clone counter value.

Table 54: Main Key Exchange message structure

Main_Key_Exchange () {	Bits	Bytes	Bit Number/Description
<b>Connection_ID</b>	<b>32</b>	<b>4</b>	<b>MAC connection identifier</b>
<b>Flags</b> Reserved FL_Initializing FL_Update_Cookie FL_Update_Counter FL_Session_Key	4 1 1 1 1	<b>1</b>	7...4: shall be 0 3:(yes/no) first ever key exchange 2:(yes/no) make new cookie value 1:(yes/no) increment clone counter 0: select session key 0 or 1
<b>Reserved</b>	<b>8</b>	<b>1</b>	<b>Reserved for future use, shall be 0</b>
<b>Nonce</b>		P <sub>ns</sub>	<b>Random string nonce1</b>
<b>DH_Modulus</b>		P <sub>pka</sub>	<b>Diffie-Hellman modulus m</b>
<b>DH_Generator</b>		P <sub>pka</sub>	<b>Diffie-Hellman generator g</b>
<b>DH_Public_X</b>		P <sub>pka</sub>	<b>Diffie-Hellman public value X</b>
}			

The FL\_Session\_Key bit specifies which session key of the security context to update.

If the FL\_Update\_Counter bit is set, it instructs the NIU to increment its clone detection counter.

If the FL\_Update\_Cookie bit is set, it instructs the NIU to generate a new cookie value to be used for future authentications and key exchanges, and to reset the clone detection counter to zero.

Any updates to the cookie, clone counter, or their associated sequence number bits do not take effect until the following <MAC>**Connect Confirm** message is received by the NIU.

If the `FL_Initializing` bit is set, it tells the NIU that the `Authenticator` field in the response will be ignored.

The sizes of the multi-byte fields are determined by the parameters of the algorithms selected during security sign-on (see clause 5.8.9.1).

The INA will use its own private Diffie-Hellman value,  $x$ , together with the fields of the response message from the NIU to derive the new session key value, as well as any new value for the cookie (see clause 5.8.2).

#### 5.8.9.4 <MAC>Main Key Exchange Response (Upstream)

The Main Key Exchange Response message authenticates the NIU and completes the cookie-independent key exchange with the INA. It also contains the current value of the clone detection counter.

**Table 55: Main Key Exchange Response message structure**

Main_Key_Exchange_Re-sponse () {	Bits	Bytes	Bit Number/Description
<b>Connection_ID</b>	<b>32</b>	<b>4</b>	<b>MAC connection identifier</b>
<b>Flags</b>		<b>1</b>	
Reserved FL_Cookie_SN	6		7...2: shall be 0
FL_Counter_SN	1		1: cookie sequence number
	1		0: clone counter sequence number
<b>Clone_Counter</b>	<b>8</b>	<b>1</b>	<b>Current clone counter value</b>
<b>Nonce</b>		<b>P<sub>ns</sub></b>	<b>Random string nonce2</b>
<b>Authenticator</b>		<b>P<sub>ha</sub></b>	<b>Authentication value auth</b>
<b>DH_Public_Y</b>		<b>P<sub>pka</sub></b>	<b>Diffie-Hellman public value Y</b>
}			

The `FL_Counter_SN` bit is the current sequence number of the clone detection counter. The **Clone\_Counter** field is the current value of the counter. A clone collision has been detected if the INA finds a mis-match from the expected value.

The `FL_Cookie_SN` bit is the sequence number of the cookie used for authentication.

If the `FL_Update_Cookie` bit was set by the INA, the NIU will generate a new cookie value and complement the cookie sequence number bit. It will also reset the clone counter value to zero and clear the clone counter sequence number bit.

If the `FL_Update_Counter` bit was set by the INA, the NIU will increment the value of the clone counter (modulo 256) and complement the clone counter sequence number bit.

Any updates to the cookie, clone counter, or their associated sequence number bits do not take effect, and shall not be committed to non-volatile storage, until the following <MAC>**Connect Confirm** message is received by the NIU.

The NIU uses its private Diffie-Hellman value,  $y$ , together with the message fields to derive the new session key value, as well as any new value for the cookie (see clause 5.8.2).

#### 5.8.9.5 <MAC>Quick Key Exchange (Single-cast Downstream)

The Quick Key Exchange message is used to start a cookie-dependent key exchange with the NIU, and also instructs the NIU whether to update its clone counter value.



Table 56: Quick Key Exchange message structure

Quick_Key_Exchange () {	Bits	Bytes	Bit Number/Description
Connection_ID	32	4	MAC connection identifier
Flags	8	1	
Reserved FL_Update_Counter	6		7...2: shall be 0
FL_Session_Key	1		1:(yes/no) increment clone counter
	1		0: select session key 0 or 1
Reserved	8	1	Reserved for future use, shall be 0
Nonce		P <sub>ns</sub>	Random string nonce <sup>1</sup>
}			

The FL\_Session\_Key bit specifies which session key of the security context to update.

If the FL\_Update\_Counter bit is set, it instructs the NIU to increment its clone detection counter.

The INA will use its knowledge of the cookie value together with the fields of the response message from the NIU to derive the session key value (see clause 5.8.3).

#### 5.8.9.6 <MAC>Quick Key Exchange Response (Upstream)

The Quick Key Exchange Response message authenticates the NIU and completes the cookie-dependent key exchange with the INA. It also contains the current value of the clone detection counter.

Table 57: Quick Key Exchange Response message structure

Quick_Key_Exchange_Re-sponse () {	Bits	Bytes	Bit Number/Description
Connection_ID	32	4	MAC connection identifier
Flags		1	
Reserved	6		7...2: shall be 0
FL_Cookie_SN	1		1: cookie sequence number
FL_Counter_SN	1		0: clone counter sequence number
Clone_Counter	8	1	Current clone counter value
Nonce		P <sub>ns</sub>	Random string nonce <sup>2</sup>
Authenticator		P <sub>ha</sub>	Authentication value auth
}			

The FL\_Cookie\_SN bit is the sequence number of the cookie used for authentication.

The FL\_Counter\_SN bit is the current sequence number of the clone detection counter. The Clone\_Counter field is the current value of the counter. A clone collision has been detected if the INA finds a mis-match from the expected value.

If the FL\_Update\_Counter bit was set by the INA, the NIU will increment the value of the clone counter (modulo 256) and complement the clone counter sequence number bit. The updated values do not take effect, and shall not be committed to non-volatile storage, until the following <MAC>Connect Confirm message is received by the NIU.

The NIU uses the cookie value together with the message fields to derive the session key value (see clause 5.8.3).

#### 5.8.9.7 <MAC>Explicit Key Exchange (Single-cast Downstream)

The Explicit Key Exchange message is used to securely deliver an existing session key value to the NIU, and also instructs the NIU whether to update its clone counter value.

Table 58: Explicit Key Exchange message structure

Explicit_Key_Exchange () {	Bits	Bytes	Bit Number/Description
Connection_ID	32	4	MAC connection identifier
Flags		1	
Reserved	6		7...2: shall be 0
FL_Update_Counter	1		1:(yes/no) increment clone counter
FL_Session_Key	1		0: select session key 0 or 1
Reserved	8	1	Reserved for future use, shall be 0
Nonce		P <sub>ns</sub>	Random string nonce1
Encryptedkey		P <sub>ea</sub>	Encrypted session key
}			

The FL\_Session\_Key bit specifies which session key of the security context to update.

If the FL\_Update\_Counter bit is set, it instructs the NIU to increment its clone detection counter.

The INA has used its knowledge of the cookie value to encrypt the session key value (see clause 5.8.4).

#### 5.8.9.8 <MAC>Explicit Key Exchange Response (Upstream)

The Explicit Key Exchange Response message authenticates the NIU and acknowledges receipt of the delivered key. It also contains the current value of the clone detection counter.

Table 59: Explicit Key Exchange Response message structure

Explicit_Key_Exchange_Response () {	Bits	Bytes	Bit Number/Description
Connection_ID	32	4	MAC connection identifier
Flags		1	
Reserved	6		7...2: shall be 0
FL_Cookie_SN	1		1: cookie sequence number
FL_Counter_SN	1		0: clone counter sequence number
Clone_Counter	8	1	Current clone counter value
Nonce		P <sub>ns</sub>	Random string nonce2
Authenticator		P <sub>ha</sub>	Authentication value auth
}			

The FL\_Cookie\_SN bit is the sequence number of the cookie used for authentication and session key decryption. If the INA determines that it has used the wrong cookie for session key encryption it will re-issue the <MAC>Explicit Key Exchange using the old cookie value.

The FL\_Counter\_SN bit is the current sequence number of the clone detection counter. The Clone\_Counter field is the current value of the counter. A clone collision has been detected if the INA finds a mis-match from the expected value.

If the FL\_Update\_Counter bit was set by the INA, the NIU will increment the value of the clone counter (modulo 256) and complement the clone counter sequence number bit. The updated values do not take effect, and shall not be committed to non-volatile storage, until the following <MAC>Connect Confirm message is received by the NIU.

The NIU uses the cookie value together with the message fields to decrypt the session key value (see clause 5.8.4).

#### 5.8.9.9 <MAC>Wait (Upstream)

The Wait message is used by the NIU to extend the time the INA waits for a reply to a given message. Upon receiving it, the INA will reset its time-out value and retry count (see clause 5.8.8.1).

**Table 60: Wait message structure**

Wait () {	Bits	Bytes	Bit Number/Description
Connection_ID	32	4	MAC connection identifier
Message_Type	8	1	Type of message from INA
Reserved	8	1	Reserved for future use, shall be 0
}			

The **Message\_Type** field is the message type value of the message received from the INA being processed. If the message is specific to a connection, the **Connection\_ID** field identifies which; otherwise this field is zero. The NIU indicates that it is currently unable to send a reply to the message.

## 6 Interactive Cable STB/Cable Data Modem Mid Layer Protocol

This clause describes the mid layers to be used when the present document is used to implement Interactive Cable STB respectively Cable Data Modem applications. Three solutions are given for this application, Direct IP, Ethernet MAC bridging and PPP. Direct IP is mandatory for both INA and NIU, the other two solutions are optional. Interoperability testing will be performed on Ethernet MAC bridging until end 99.

### 6.1 Direct IP

The goal of this clause is to allow compatible and interoperable implementations for transmitting IP datagrams [11] over ATM AAL5 [8] and DVB Multiprotocol Encapsulation [6], as used by the present document for upstream and downstream transmission.

#### 6.1.1 Framing

INA and NIU/STB shall support an MTU size of 1 500 Byte.

##### 6.1.1.1 Upstream and OOB Downstream

The IP datagram shall be carried as such in the payload of the AAL5 CPCS-PDU. This method is described in IETF/RFC 1483 [8] as VC based multiplexing for routed protocols and is generally also known as null encapsulation.

##### 6.1.1.2 IB Downstream

The IP datagram shall be carried as such in the DVB Multiprotocol Encapsulation sections of EN 301 192 [6], LLC\_SNAP\_flag is set to zero. Each IP datagram shall be carried in a single section.

### 6.1.2 Addressing

In upstream framing structure and in downstream out-of-band framing structure, the addressing of a specific NIU/STB is done with a VPI/VCI pair. At least one VPI/VCI pair is assigned per NIU/STB. The following VPI/VCI pairs are reserved:

**Table 61: Reserved VPI/VCI values**

VPI/VCI	remark
any/0x0000...0x001F	reserved for ATM use
0x00/0x0020	reserved for DAVIC use
0x00/0x0021	reserved for DVB MAC messages
0x00/0x0022	reserved for DirectIP broadcast
0x00/0x0023	reserved for Ethernet MAC Bridging broadcast

All other VPI/VCI pairs can be assigned by the INA for carrying IP traffic. The VPI/VCI is provided through the DVB MAC protocol.

#### 6.1.2.1 IP Broadcast and Multicast from STB/NIU to INA

All upstream IP broadcast and multicast packets shall be transmitted with an upstream VPI/VCI given in a MAC connect message.

#### 6.1.2.2 IP Broadcast and Multicast from INA to STB/NIU

##### **IB downstream**

For IB downstream, IP broadcast and multicast shall be carried out according to EN 301 192 [6] as described below.

IB downstream IP broadcast shall be transmitted with the broadcast MAC address FF:FF:FF:FF:FF:FF. An IP multicast group is joined according to the IGMP protocol [13]. Additionally, the INA may assign a new DVB MAC connection to the NIU/STB for that purpose, including a multicast MAC address. IB downstream multicast shall then be transmitted with that multicast MAC address.

##### **OOB downstream**

OOB downstream IP broadcast shall be transmitted with a VPI/VCI value of 0x00/0x0022. An IP multicast group is joined according to the IGMP protocol [13]. Additionally, the INA may assign a new MAC connection to the NIU/STB for that purpose. QPSK downstream multicast shall then be transmitted with the VPI/VCI given in the corresponding MAC connect message.

### 6.1.3 IP Address Assignment

The NIU/STB shall use either the BOOTP or the DHCP protocol according to IETF/RFC 951 [10] and IETF/RFC 2131 [9] to get an IP address from the network, unless a fixed IP address was assigned to the NIU/STB by the operator and made known to the INA. All additional IP addresses of customer premises equipment connected to the NIU/STB shall be assigned through BOOTP or DHCP, unless fixed IP addresses have been assigned by the operator. Singlecast downstream traffic with a destination IP address not assigned through BOOTP, DHCP or the operator shall be discarded by the INA. Upstream traffic with a source host IP address not assigned through BOOTP, DHCP or the operator shall be discarded by the NIU/STB and by the INA.

#### 6.1.4 INA Interfaces (Informative)

t.b.d.

#### 6.1.5 NIU/STB Interfaces (Informative)

t.b.d.

## 6.2 Ethernet MAC Bridging

The goal of this clause is to allow compatible and interoperable implementations for transmitting ISO 8802-3 [15] Ethernet MAC frames over ATM AAL5 [8] and DVB Multiprotocol Encapsulation [6], as used by the present document for upstream and downstream transmission.

### 6.2.1 Framing

#### 6.2.1.1 Upstream and OOB Downstream

The Ethernet MAC frame shall be carried in the payload of the AAL5 CPCS-PDU as described in IETF/RFC 1483 [8] as LLC encapsulation for bridged Ethernet/802.3 PDUs, using PID 0x00-07 (LAN FCS is not transmitted). No padding bytes are inserted between the LLC/SNAP header and the Ethernet MAC frame.

### 6.2.1.2 IB Downstream

The Ethernet MAC frame shall be carried in the payload of the DVB Multiprotocol Encapsulation sections as described in EN 301 192 [6], LLC\_SNAP\_flag is set to one. The value of the LLC/SNAP header is 0xAA-AA-03-00-80-C2-00-07. Each Ethernet MAC frame shall be carried in a single section.

## 6.2.2 Addressing

In upstream framing structure and in downstream out-of-band framing structure, the addressing of a specific NIU/STB is done with a VPI/VCI pair. At least one VPI/VCI pair is assigned per NIU/STB. The VPI/VCI pairs according to Table 61 are reserved.

All other VPI/VCI pairs can be assigned by the INA for carrying Ethernet traffic. The VPI/VCI is provided through the DVB MAC protocol.

## 6.3 PPP

The goal of this clause is to allow compatible and interoperable implementations for transmitting PPP packets over ATM AAL5 and DVB Multiprotocol Encapsulation [6], as used by the present document for upstream and downstream transmission.

### 6.3.1 Framing

The implementation shall be done according to the IETF RFC 2364 [22], as mentioned in paragraph 5.

#### 6.3.1.1 Upstream and OOB Downstream

The PPP frame shall be carried as such in the payload of the AAL5 CPCS-PDU. This method is described in IETF RFC 2364 [22] (Figure 1). The flag sequences, that delimit the beginning and the end of each frame, do not exist any more. The Asynchronous-Control-Character-Map (ACCM) is not negotiated. In this way, the stuffing procedure is no longer necessary.

#### 6.3.1.2 IB Downstream

The PPP datagrams shall be carried in the payload of the DSM-CC sections as described in EN 301 192 [6] (DVB multiprotocol encapsulation) with the LLC\_SNAP\_flag set to one. The encapsulation of PPP into LLC/SNAP is defined in IETF RFC 2364 [22] "PPP over AAL5" (with the NLPID value for PPP set to 0xCF). Each PPP frame shall be carried in a single section.

### 6.3.2 Addressing

In upstream framing structure and in downstream out-of-band framing structure, the addressing of a specific NIU/STB is done with a VPI/VCI pair. At least one VPI/VCI pair is assigned per NIU/STB. The VPI/VCI pairs according to Table 61 are reserved.

All other VPI/VCI pairs can be assigned by the INA for carrying PPP traffic. Each PPP connection will be associated to one VPI/VCI provided through the MAC DVB RC protocol.

### 6.3.3 IP Address Assignment

After receiving the MAC Connect confirm message, the NIU/STB uses IPCP protocol included in the PPP protocol, according to IETF RFC 1332 [23] to get an IP address from the network. The PPP protocol supports the case of a fixed IP address assigned to the STB/NIU.

In the case a fixed IP address has been assigned to the NIU/STB by the operator, the IPCP protocol shall be used to make this IP address known to the INA. The PPP IPCP *Configure-Request* of the NIU/STB states which IP-address is used.

The INA can provide an(other) IP address by NAKing this option, and returning a valid IP-address. The NIU/STB shall use this IP address even in the case, the NIU/STB has a fixed one.

### 6.3.4 Additional IP addresses

In the case the NIU/STB is also connected to customer premises equipment by a LAN, one of the following IP address assignment schemes shall be implemented:

- 1) the LAN has its own IP subnet address and subnet mask, in this case the NIU/STB acts like a router i.e. the IP subnet address and subnet mask of the LAN is completely independent of the INA. Or,
- 2) BOOTP/DHCP messages from the LAN are sent transparently through the PPP link to a server at the INA side.

Singlecast downstream traffic with a destination IP address not assigned through PPP or BOOTP/DHCP shall be discarded by the INA. Upstream traffic with a source host IP address not assigned PPP or BOOTP/DHCP shall be discarded by the NIU/STB and by the INA.

### 6.3.5 Security

The PAP or CHAP protocols will supply authentication and authorization mechanisms both included in PPP.

### 6.3.6 INA Interfaces (informative)

t.b.d.

### 6.3.7 NIU/STB Interfaces (informative)

t.b.d.

---

## Annex A (informative): MAC State Transitions and Time Outs

The boxes represent states, state-transitions are represented by arrows. State-transitions are triggered by events, denoted by: "Ex: <event>". Triggers are either the reception of MAC-messages or Time-Outs. An event can lead to a state-transition depending on a condition, this is denoted by "Ex: <event> && <condition>".

A time-out timer runs in all the states. The values of these time-out counters are denoted by Tx.

On the following pages the events are accompanied by actions that are performed by the state machine during the state transition. Some actions are performed only under a certain condition. To make this clear, "if then else" constructions are used.

## A.1 Initialization, Provisioning, Sign-On and Calibration

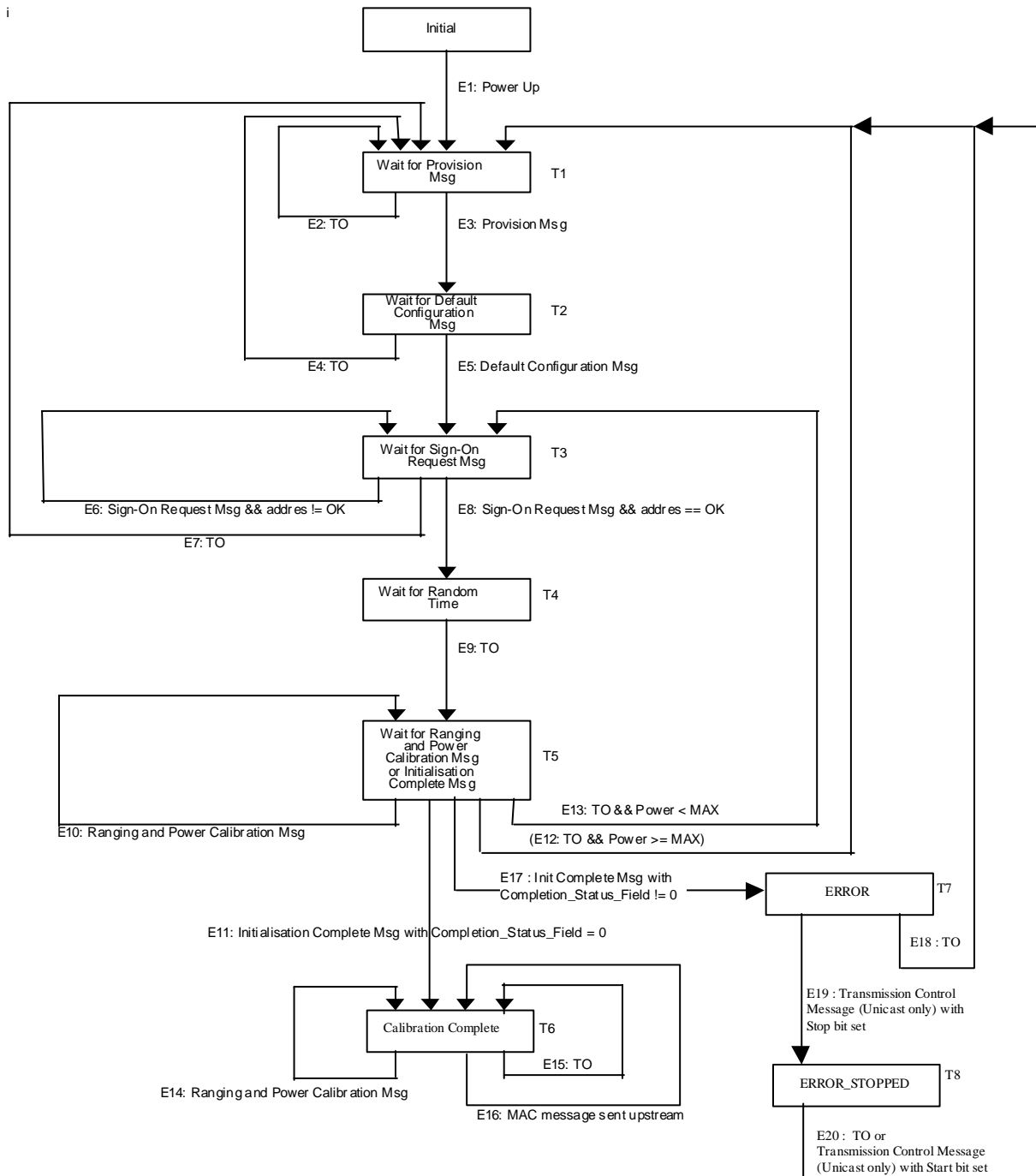

**Figure A.1: State Diagram for Ranging and Calibration**

- E1 Power up:  
Tune to any downstream channel  
(re)set timeout to T1
- E2 Time Out received:  
Tune to next downstream channel  
(re)set timeout to T1







## A.2 Connection Establishment

Two cases of connection establishment exist: connection establishment of the first or default connection, and connection establishment of additional connections after the default connection has been successfully established.

If the STB detects the continuous loss of carrier or framing for longer than LofTimeout, then the STB will consider all connections released and will go to the Wait for Login state (T0?).

### Default Connection Establishment

This procedure is started after a successful Sign-On and Calibration procedure. A special case exists when the STB loses the Initialization Complete Message but receives a Connect Message. In this special case, the STB shall proceed as if the Initialization Complete Message had been received.

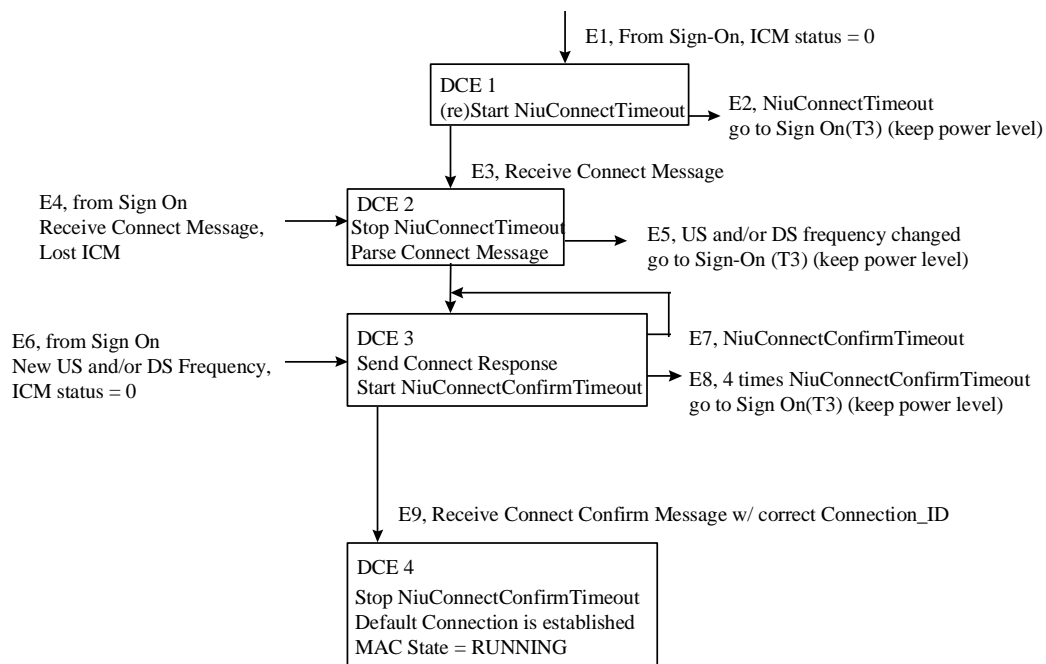

### Subsequent Connection Establishment

This procedure can be entered only when the STB has at least one operating (i.e. not STOPPED via a TCM) connection.

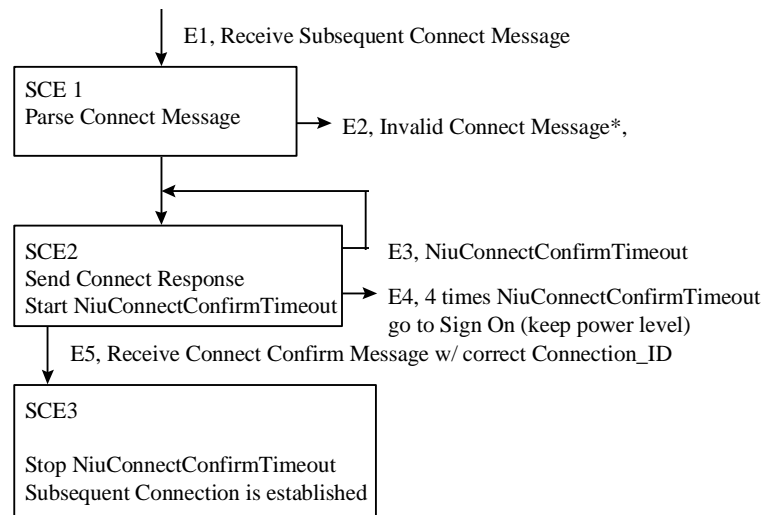

\* Subsequent Connect Message Validity

```

if (US frequency is different than the current US frequency) {
    message invalid
} else if (Connect Message contains both an IB and OOB DS frequency) {
    message invalid
} else if (Connect Message contains an IB freq and the STB currently has an open connection on a different IB freq) {
    message invalid
} else if (Connect Message contains an OOB freq and the STB currently has an open connection on a different OOB freq) {
    message invalid
}
  
```

## A.3 Connection Release

The STB may release connections only when it has at least one operating (i.e. not STOPPED by TCM) connection. If the STB has its number of connections reduced to one connection then the remaining connection is considered the default connection.

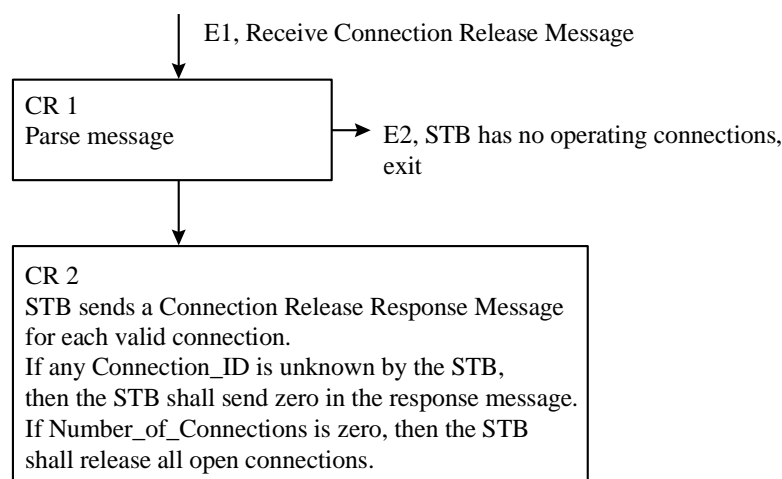

## A.4 Reservation Process

The Figure below gives a state diagram of the reservation process. The boxes represent states, state-transitions are represented by arrows. State-transitions are triggered by events, denoted by "Ex:<event>". Triggers are either the reception of MAC messages or time outs. An event can lead to a state-transition depending on a condition; this is denoted by "Ex:<event>&&<condition>".

A pending slot is defined as a slot for which no reservation request has been sent yet.

A requested slot is defined as a slot for which a reservation request has already been sent, but which is not yet granted.

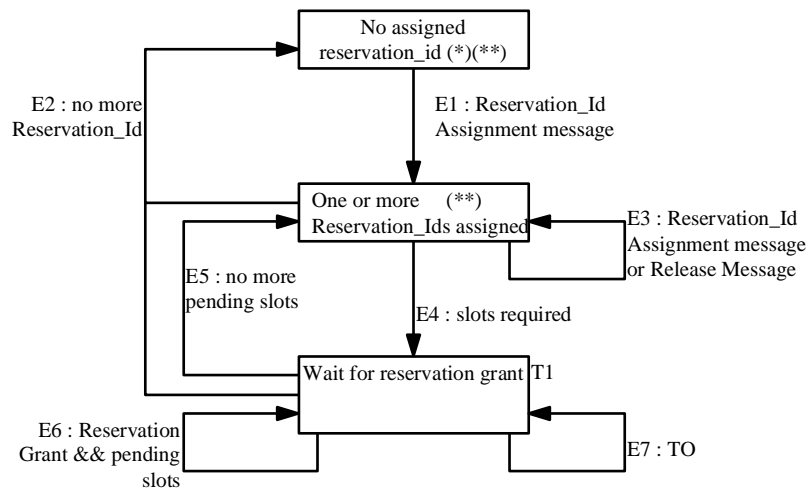

(\*) No assigned Reservation\_id' State is to be linked to the state diagram of connection establishment process.

(\*\*) No Time-Out is associated to this state since when transition shall occur is not in the scope of the present document.

- E1** Reservation\_Id Assignment message:  
 If a 'Reservation\_Id assignment' message is received with a valid connection\_id  
 Send a 'Reservation\_id response' message  
 Consider new parameters  
 Go to 'One or more Reservation\_Ids assigned'
- E2** No more reservation\_Id:  
 If a 'Release' message closes the last connection with an assigned reservation\_id,  
 Delete all slots allocated in reservation region for this connection  
 Go to 'No assigned reservation\_id' state  
 If a 'Reprovisioning' message is received with 'Delete\_Reservation\_IDs' bit set,  
 Delete all slots allocated in reservation region  
 Go to 'No assigned reservation\_id' state
- E3** 'Reservation\_Id Assignment' message or 'Release' message  
 If a 'Release' message closes the connection with an assigned reservation\_id (but not the last),  
 Delete all slots allocated in reservation region for this connection  
 Stay in same state  
 If a 'Reservation\_Id assignment' message is received with a valid connection\_id  
 Consider new parameters  
 Send a 'Reservation\_ID\_Response' message  
 Stay in same state

- E4 Reservation slots are required by the NIU:  
 If Piggy Back allowed and is being implemented  
   Send Piggy Back request by setting the appropriate GFC field bit on any upstream ATM cell of this connection  
   **OR**  
   Send a 'Reservation Request' message with reservation\_id corresponding to the connection  
 Maintain count of pending slots and requested slots for this connection  
 Set a timer to T1 (equal to 'grant\_protocol\_timeout' associated to the reservation\_id)  
 Go to 'Wait for reservation grant' state  
   **OR**  
 If (Continuous\_Piggy\_Back\_Timeout != 0) and (continuous piggyback timer not elapsed)  
   Send a 'Request indication' via Piggybacking in the last granted slot indicating the request of the minimum number of slots possible  
   If this is the first continuous piggyback request, set timer for continuous piggybacking to "Continuous\_Piggy\_Back\_Timeout"  
   Set timer of the connection to T1 (function of 'grant\_protocol\_timeout' associated to the reservation\_id)  
   Go to 'Wait for reservation grant' state
- E5 Reservation Grant message granting all requested slots:  
 If a 'reservation grant' message grants all the previous requests (i.e. with 'remaining\_slot\_count' field set to 0) and no pending slots  
   Disable active timers  
   Go to 'One or more Reservation\_IDs assigned' state
- E6 Reservation Grant message but requested slots still to be granted:  
 If a 'reservation grant' message grants previous requests (but not all or some with 'remaining\_slot\_count' field different from 0)  
   For connection with request not completely granted  
     Set timer of the connection to T1 (equal to 'grant\_protocol\_timeout' associated to the reservation\_id)  
     Update number of requested slots with 'granted slot count' field  
     If 'remaining\_slot\_count' < 15 and (pending\_slot\_count != 0 or requested\_slot\_count != remaining\_slot\_count)  
       If Piggy Back allowed and is being implemented  
         Send Piggy Back request by setting the appropriate GFC field bit on the next upstream ATM cell - either a contention based ATM cell, a reservation based PDU or a fixed access based ATM cell  
         **OR**  
         Send a 'Reservation Request' message with reservation\_id corresponding to the connection  
         Maintain count of pending slots and requested slots for this connection  
     For completely granted connection  
       Disable timer of the connection  
       Set number of requested slots to 0 for this connection  
       If pending slots exist  
         If Piggy Back allowed and is being implemented  
           Send Piggy Back request by setting the appropriate GFC field bit on the next upstream message - either a contention based ATM cell, a reservation based PDU or a fixed access based ATM cell  
           **OR**  
           Send a 'Reservation Request' message with reservation\_id corresponding to the connection  
           Maintain count of pending slots and requested slots for this connection  
           Set timer of the connection to T1 (function of 'grant\_protocol\_timeout' associated to the reservation\_id)  
 If new slots are required for a connection, update number of pending slots.  
 Stay in same status

- E7 Time Out received:  
If an active timer ellapsed  
    Send a reservation status request message for the associated connection  
Set timer of the connection to T1 (function of 'grant\_protocol\_timeout' associated to the reservation\_id)  
If new slots are required for a connection, update number of pending slots.  
Stay in same status

Time-out T1 is dynamically set by the INA in the 'Reservation\_Id\_Assignment' message (grant\_protocol\_timeout parameter).

---

## A.5 Resource Request

The NIU uses the <MAC> Resource Request Message to request a new connection or to change the parameters associated with an existing connection. In the above cases the resource allocation process is initiated by the NIU. After this initiation, the connections are allocated or changed by the INA using the MAC processes previously defined.

The following gives a state diagram of the Resource Request Processes, in terms of the processes already described and using the terminology as in the previous clauses.

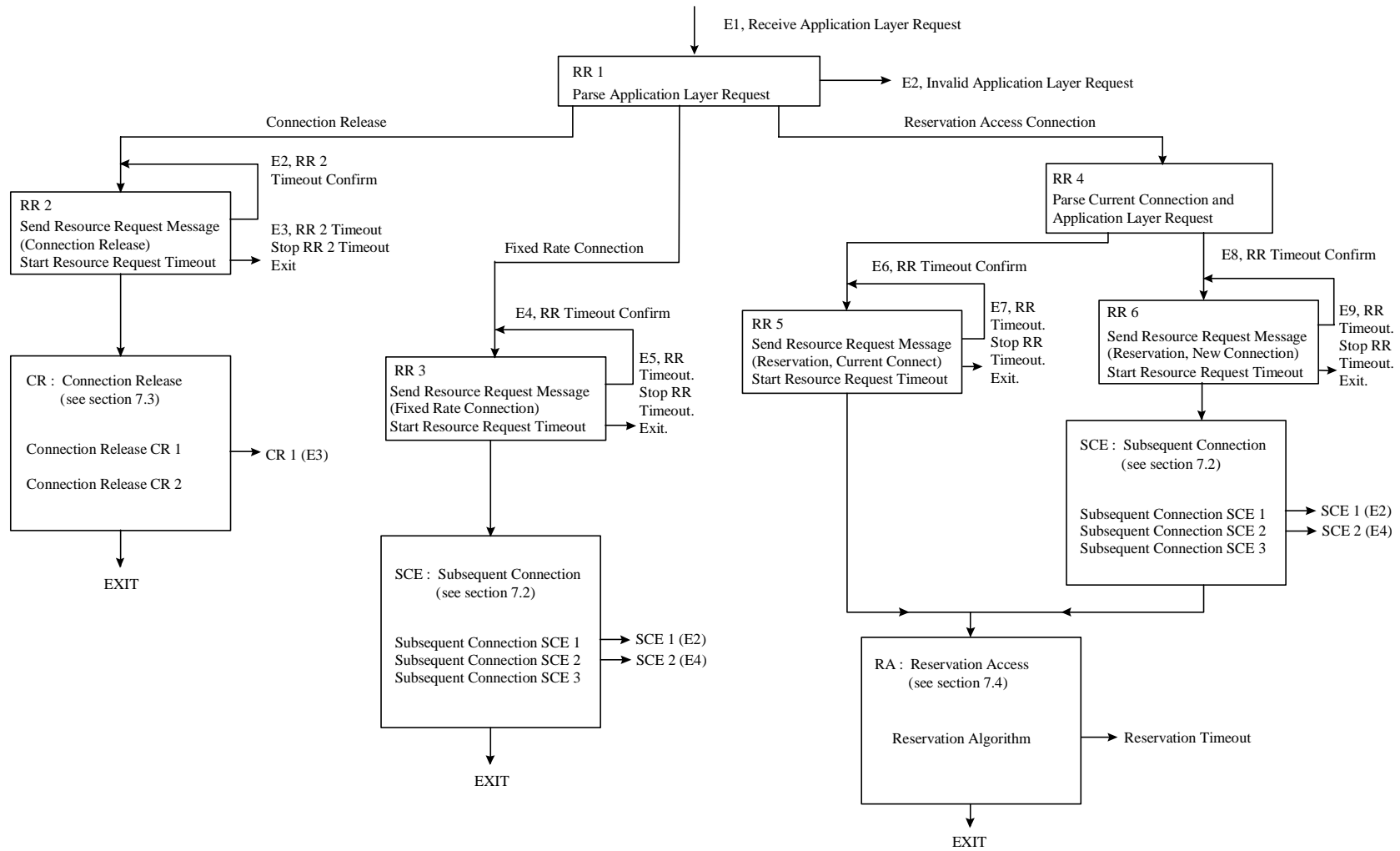



## A.6 Recalibration

The STB may be recalibrated whenever it has at least one open (i.e. STOPPED or RUNNING) connection.

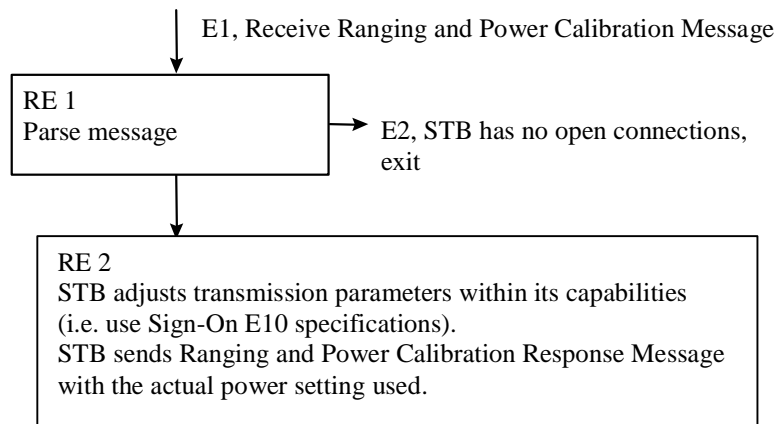

## A.7 Reprovision Message

The STB can be reprovisioned whenever it has at least one operating connection.

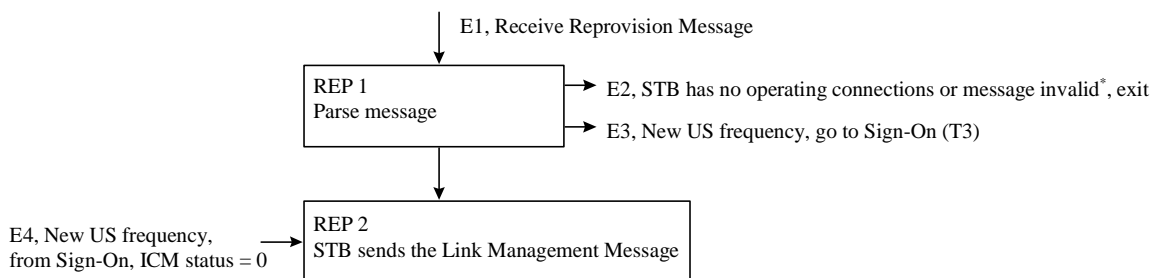

\* Reprovision Message Validity

Besides invalid parameter values, the received Reprovision Message will be considered invalid if the message contains both new Cyclic **and** Slot List assignments

## A.8 Transmission Control Message

The Transmission Control Message (TCM) controls aspects of upstream and downstream transmission. The commands are sent to the STB in either broadcast or singlecast mode. The STB is in one of the following MAC states:

- RUNNING, the STB has at least one operating connection.
- STOPPED, the STB has received a TCM Stop Upstream Transmission command.
- ERROR, the STB has received a ICM with non-zero Completion\_Status\_Field.
- ERROR\_STOPPED, the STB was in the ERROR state and received a TCM Stop\_Upstream\_Transmission command.
- NONE, the STB has no open connections.

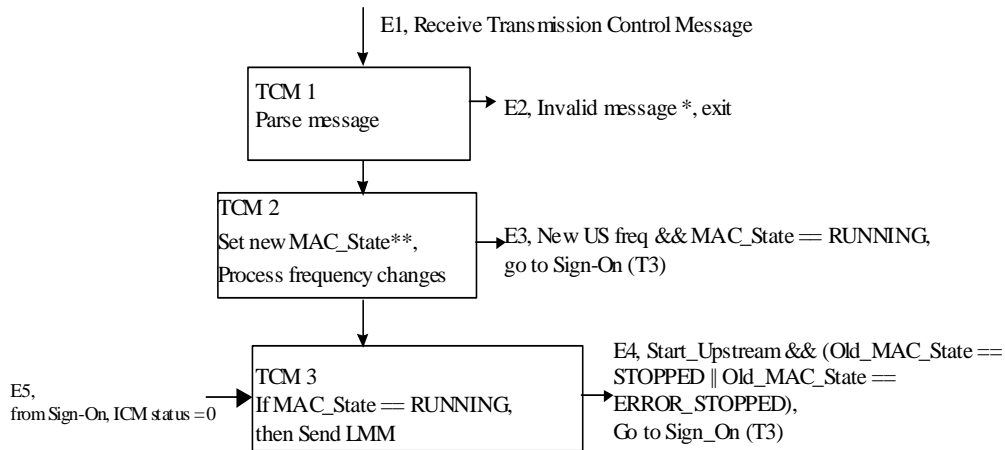

\* Invalid TCM

Besides invalid parameter values, the received TCM will be considered invalid if

(Start\_Upstream\_Transmission && Stop\_Upstream\_Transmission) or (Old\_Frequency != CurrentFrequency) in which case the STB will ignore the message.

\*\* new MAC

```

if (Start_Upstream_Transmission == 0 && Stop_Upstream_Transmission == 0) {
    New_MAC_State = Old_MAC_State
} else if (Start_Upstream_Transmission == 0 && Stop_Upstream_Transmission == 1) {
    if (Old_MAC_State == ERROR) New_MAC_State = ERROR_STOPPED
    else if (Old_MAC_State == ERROR_STOPPED) New_MAC_State = ERROR_STOPPED
    else New_MAC_State = STOPPED
} else if (Start_Upstream_Transmission == 1 && Stop_Upstream_Transmission == 0) {
    if (Old_MAC_State == ERROR) New_MAC_State = ERROR
    else if (Old_MAC_State == ERROR_STOPPED && Broadcast) New_MAC_State = ERROR_STOPPED
    else New_MAC_State = RUNNING
}
  
```

## A.9 Status Request Message

The STB can be queried for status whenever it has at least one operating connection.

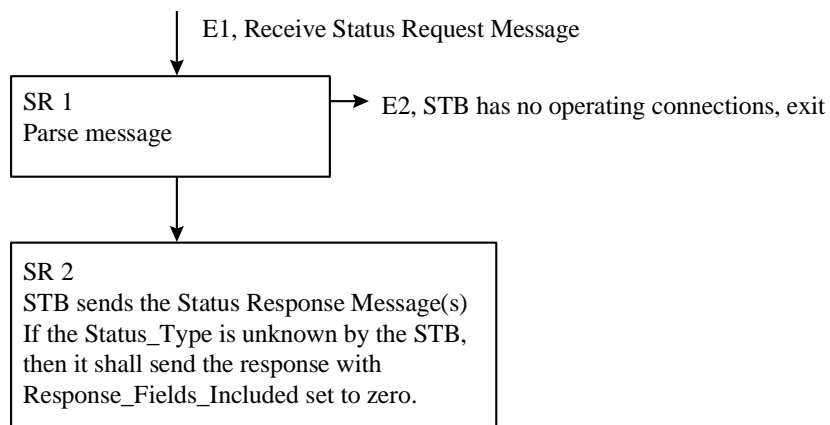

---

## A.10 Idle Message

The Idle Message is sent during periods of Upstream MAC message inactivity that exceeds a non-zero Idle\_Interval by the STB whenever it has at least one operating connection.

## Annex B (informative): MAC Primitives

In order to provide a common way to interface to the MAC functions, primitives are defined above the MAC Layer. These primitives are intended to cover both the Cable Modem (CM) and SetTopBox (STB) applications, and the INA function of the Head-Ends.

The MAC responsibility is mainly:

- The synchronization of the STB/CM to the network (initial physical link set-up) and establishment of the initial Connection.
- The management of the subsequent Connections between the INA and the STB/CM. (It gets the Connections allocated by the INA and insures also the functions relative to the various modes of communication, for example the acknowledgement of contention based transmissions or the reservation requests of bandwidth when needed).
- The periodical Link Management functions that insure a correct physical link (for example the power level and time offset modifications, or the re-assignments of resources requested by the INA).

The interface between MAC and the upper layer has been implemented using primitives. They have been defined as usually in the OSI layer model architecture.

Prefix	Identifier of the layer that provides the service.
Core	Name of the primitive, it is relative to the action performed.
Suffix	Indication of the data direction.

The advantage of primitives is that they provide a clear and deterministic mean of exchange between layers. In addition, this method permits an easier adaptation work as the final products can be implemented with various physical links between the NIU and the upper entity.

The MAC primitives can be split into two sets:

- The MAC Control and Resource primitives cover the signalling and link management information exchange between the MAC layer and the management entity of the STB/CM or the INA (clause B.1).
- The MAC Data primitives cover the transport of data application payload between the MAC layer and upper layer entities (clause 8.2).

The primitives correspond to an event. They carry parameters. In order to facilitate their identification and by consequence their processing they are identified by a unique id.

The id (Primitive\_id) is coded on 16 bits. The rules of numbering are:

b15 – b12	: Layer	: 0 = MAC, 1 = DL (other values (2 to 0xF) are reserved)
b11	: Control/data	: 1 the primitive is a control primitive, 0 the primitive is a data primitive
b10 – b0	: Primitive Nb	: root value of the Primitive_id

The root value of the Primitive\_id will be assigned starting from the value 1.

The primitives correspond to the definition of services that are deduced from the features of the MAC layer. But the various implementations of the present document will probably need more information exchanges based on new messages for manufacturers specificity. In order to allow the definition and usage of proprietary primitives, the values starting at 0x7FF and assigned on a decreasing scheme down to 0x400 can be used.

All parameters of the primitives are coded in the order they are listed, with the MSB first for each parameter. Unless otherwise noted, the type of the parameters is unsigned integer.

## B.1 Control and Resource Primitives

### B.1.1 On STB/CM side

#### B.1.1.1 <Prim> MAC\_ACTIVATION\_REQ

Parameter	Format	Comment
Primitive_id	16	0x0801
DS_Type	8	Downstream type
DS_IB_Symb_Rate_Nb	8	Number of In Band Symbol rates to try
DS_IB_Symb_Rate_List	16[Nb]	List of Symbol rate values (in Ksymbol/s)
DS_Freq_Nb	8	Number of Frequencies to try
DS_Freq_List	32[Freq_Nb]	List of Frequencies to try (in Hz)

The management entity asks the MAC layer to start the processing of network synchronization. It can provide the type of Downstream Channel. The list of frequencies is passed to accelerate the scanning. If no frequency is mentioned (Freq\_Nb = 0), the MAC layer will make a scan on the full set of DVB-RC frequencies.

In Band mode, the requestor can specify the Symbol rate. If it is not specified (i.e. DS\_IB\_Symb\_Rate\_Nb = 0), the MAC layer will try all the possible values.

After receiving this primitive, the MAC layer set-up the first frequency and starts the initial synchronization processing (Provisioning, Default Configuration, Sign-On exchange, Ranging and Power Calibration, Init Complete).

If it is not successful, the process is re-started for each new frequency of the list.

If all given frequencies in the list fail, a full scan is done.

When the Init Complete message is correctly decoded, or when the full set of frequencies and the full set of implemented downstream types has been tried without success, the primitive MAC\_ACTIVATION\_CNF is sent, specifying the success or the reason of the failure.

**DS\_Type** : 0 : OOB 1,544 Mbit/s 1 : OOB 3,088 Mbit/s 2 : IB MPEG 255 : All possible

**DS\_IB\_Symb\_Rate\_Nb** : Number of In Band Symbol Rate values to be used

**DS\_IB\_Symb\_Rate\_List** : Table of IB Symbol Rate values, unit is Ksymbol/s

**DS\_Freq\_Nb** : Number of frequencies to try (next parameter)

**DS\_Freq\_List** : Table of frequency values, coded in Hertz.

#### B.1.1.2 <Prim> MAC\_ACTIVATION\_CNF

Parameter	Format	Comment
Primitive_id	16	0x0802
Error_Code	32	Success or reason of the failure
DS_Frequency	32	Downstream frequency effectively used
DS_Type	8	Downstream type effectively used
DS_Symb_Rate	16	Downstream In Band symbol rate effectively used (Ksymbol/s)
US_Frequency	32	Upstream frequency used
US_Type	8	Upstream type used
INA_Capabilities	32	Capabilities of the INA

This primitive indicates the result of the MAC\_ACTIVATION\_REQ or the change of any of the listed parameters (for example due to reprovisioning).

**Error code:** a value of 0 means the success of the previous Activation Request, any other value will be used to indicate the reason of the failure. The least significant 8 bits are a copy of the Completion\_Status\_Field of the <MAC> Initialization Complete Message. If no <MAC> Initialization Complete Message was received, these bits are zero.

**DS\_Frequency:** Value of the downstream frequency where the MAC locked, in Hertz. Meaningless if Error\_Code  $\neq$  0.

**DS\_Type:** Downstream Type where the MAC locked (coding see above). Meaningless if Error\_Code  $\neq$  0.

**DS\_Symb\_Rate:** Downstream symbol rate in Ksym/s. Meaningless for Out Of Band and if Error\_code  $\neq$  0.

**US\_Frequency:** Upstream frequency used, in Hertz. Meaningless if Error\_code  $\neq$  0.

**US\_Type:** 0: QPSK 256 kbit/s, 1: QPSK 1,544 Mbit/s, 2: QPSK 3,088 Mbit/s, 3: QPSK 6,176 Mbit/s, 4: 16-QAM 512 kbit/s, 5: 16-QAM 3,088 Mbit/s, 6: 16-QAM 6,176 Mbit/s, 7: 16-QAM 12,352 Mbit/s. Meaningless if Error\_code  $\neq$  0.

**INA\_Capabilities:** A copy of the INA\_Capabilities field of the <MAC> Default Configuration Message in order to inform the higher layers of the NIU whether the INA is capable of Resource Requests, different encapsulation types, security, IB/OOB, ... Meaningless if Error\_code  $\neq$  0.

## B.1.1.3 &lt;Prim&gt; MAC\_CONNECT\_IND

Parameter	Format	Comment
Primitive_id	16	0x0803
Connect_Id	32	Connection identifier
Res_Req_Id	8	If not null, correspond to the identifier of a previous Resource Request
US_Fixed_Bandwidth	32	Upstream capacity of the connection in Fixed rate mode
US_Frame_length	16	The frame length for fixed rate connections
US_Fixed_rate_distance	32	The distance between frames, for fixed rate connections
DS_VP_VC_valid	8	Validity flag of the 2 next fields
DS_VPI	8	VPI value to be filtered in downstream for this connection
DS_VCI	16	VCI value to be filtered in downstream for this connection
US_frequency	32	The upstream frequency for this connection
US_VP_VC_valid	8	Validity flag of the 2 next fields
US_VPI	8	VPI value to be used in upstream for this connection
US_VCI	16	VCI value to be used in upstream for this connection
PID_valid	8	Validity flag of the next field
PID	32	MPEG PID value of the connection
MAC_add_valid	8	Validity flag of the next field
MAC_add	48	DSM-CC header MAC address of the connection
Encapsulation	8	Type of encapsulation for this connection
US_modulation_valid	8	Validity flag of the next field
US_modulation	8	The US modulation of the new connection
Priority_valid	8	Validity flag of the next field
Priority	8	Copy of the <MAC> Connect Message parameter
DS_Flowspec_valid		Validity flag of the next 3 fields
Max_packet_size	16	Copy of the <MAC> Connect Message parameter
Average_bitrate	16	Copy of the <MAC> Connect Message parameter
Jitter	8	Copy of the <MAC> Connect Message parameter
US_binding_valid	8	Validity flag of the next 10 fields
US_session_control_field	32	Control field for US session binding
NIU_client_source_IP_add	32	Copy of the <MAC> Connect Message parameter
NIU_client_destination_IP_add	32	Copy of the <MAC> Connect Message parameter
NIU_client_source_port	16	Copy of the <MAC> Connect Message parameter
NIU_client_destination_port	16	Copy of the <MAC> Connect Message parameter
Upstream_transport_protocol	8	Copy of the <MAC> Connect Message parameter
NIU_client_source_MAC_add	48	Copy of the <MAC> Connect Message parameter
NIU_client_destination_MAC_add	48	Copy of the <MAC> Connect Message parameter
US_internet_protocol	16	Copy of the <MAC> Connect Message parameter
US_session_ID	32	Copy of the <MAC> Connect Message parameter
DS_binding_valid	8	Validity flag of the next 10 fields
DS_session_control_field	32	Control field for US session binding
INA_client_source_IP_add	32	Copy of the <MAC> Connect Message parameter
INA_client_destination_IP_add	32	Copy of the <MAC> Connect Message parameter
INA_client_source_port	16	Copy of the <MAC> Connect Message parameter
INA_client_destination_port	16	Copy of the <MAC> Connect Message parameter
Downstream_transport_protocol	8	Copy of the <MAC> Connect Message parameter
INA_client_source_MAC_add	48	Copy of the <MAC> Connect Message parameter
INA_client_destination_MAC_add	48	Copy of the <MAC> Connect Message parameter
DS_internet_protocol	16	Copy of the <MAC> Connect Message parameter
DS_session_ID	32	Copy of the <MAC> Connect Message parameter

This primitive indicates that the MAC layer has received a Connect Message from the INA. The connection is either:

- the Default Connection (Connect Message) sent by the INA just after the Initialization Complete message (first connection);
- a subsequent Connect message;
- an answer to a Resource Request previously sent by the CM/STB (see Resource Request primitive);
- an indication of a change in the connection characteristics after reception of a Re provisioning message.

**Connect\_Id:** Is the identifier of the connection.

**Res\_Req\_Id:** If equal to 0, the connection corresponds to a spontaneous Connect Message coming from the INA, if not null, is the id of the corresponding Resource Request.

**US\_Bandwidth:** Gives the upstream transfer capacity in Fixed Rate mode (in slots/1200 ms). Zero if no fixed rate slots have been given by the INA.

**US\_Frame\_length:** The upstream frame length (slots), as given in the connect message, for fixed rate connections.

**US\_Fixed\_rate\_distance:** The distance between frames, for fixed rate connections as given in the connect message.

**DS\_VPI/DS\_VCI:** VPI/VCI pair if the Downstream CBD is mentioned in the Connect Message.

**US\_frequency:** The connection upstream frequency, as mentioned in the connect message.

**US\_VPI/US\_VCI:** VPI/VCI pair of the Upstream CBD, when this parameter is mentioned in the Connect Message (This parameter is provided for implementations that compose the AAL5 CPCS-PDU outside the MAC layer).

**PID\_valid:** The PID in the next field is valid (0 means invalid parameter).

**PID:** In IB, the connection uses this PID. (This parameter is provided for implementations that insure data filtering outside the MAC layer).

**MAC\_add:** In IB/MPE, a Mac address can be provided for multicast. (This parameter is provided for implementations that insure section filtering outside the MAC layer).

**Encapsulation:** Type of encapsulation provided. Correspond to the same field in the Connect message (ie. Direct\_IP, Ethernet\_Mac\_Bridging, PPP).

**US\_modulation\_valid:** The modulation in the next field is valid.

**US\_modulation:** The upstream modulation of the new connection (as given in the connect message).

#### B.1.1.4 <Prim>MAC\_RSV\_ID\_IND

Parameter	Format	Comment
Primitive_id	16	0x0804
Connect_Id	32	Connection identifier
Res_Req_Id	8	If not null, correspond to the identifier of a previous Resource Request

This primitive indicates to the upper layer that the connection can use Reservation mode from this time. It can be an answer to a previous Resource Request.

**Connect\_Id:** Is the identifier of the connection.

**Res\_Req\_Id:** If equal to 0, the Reservation Id corresponds to a spontaneous Reservation ID Assignment message coming from the INA. If not null, it gives the Identifier of a previous resource request.

#### B.1.1.5 <Prim> MAC\_RELEASE\_IND

Parameter	Format	Comment
Primitive_id	16	0x0805
Connect_Id	32	Connection identifier
Res-Req_Id	8	If not null, correspond to the identifier of a previous Resource Request

The MAC layer indicates that it has received a Release message for this connection from the INA.

**Connect\_Id:** Is the identifier of the connection.

**Res\_Req\_Id:** If equal to 0, the primitive corresponds to a spontaneous Release message coming from the INA. If not null, it gives the Identifier of a previous Resource Request from the upper layer requesting the release.



## B.1.1.6 &lt;Prim&gt; MAC\_RESOURCE\_REQ

Parameter	Format	Comment
Primitive_id	16	0x0806
Connect_Id	32	Connection identifier
Resource_Type	8	Type of Resource requested
US_Bandwidth	32	Upstream transfer capability
Slot_distance	16	Distance between slots requested
Encapsulation	8	Type of encapsulation
Admit_flag	8	LSB to be copied to the corresponding flag in the <MAC> Res Req Message
Priority_valid	8	Validity flag of the next field
Priority	8	To be copied to the <MAC> Res Req Message
Frame_Length_valid	8	Validity flag of the next field
Frame_Length	16	To be copied to the <MAC> Res Req Message
DS_Flowspec_valid	8	Validity flag of the next 3 fields
Max_packet_size	16	To be copied to the <MAC> Res Req Message
Average_bitrate	16	To be copied to the <MAC> Res Req Message
Jitter	8	To be copied to the <MAC> Res Req Message
US_binding_valid	8	Validity flag of the next 10 fields
US_session_control_field	32	Control field for the US session binding
NIU_client_source_IP_add	32	To be copied to the <MAC> Res Req Message
NIU_client_destination_IP_add	32	To be copied to the <MAC> Res Req Message
NIU_client_source_port	16	To be copied to the <MAC> Res Req Message
NIU_client_destination_port	16	To be copied to the <MAC> Res Req Message
Upstream_transport_protocol	8	To be copied to the <MAC> Res Req Message
NIU_client_source_MAC_add	48	To be copied to the <MAC> Res Req Message
NIU_client_destination_MAC_add	48	To be copied to the <MAC> Res Req Message
US_internet_protocol	16	To be copied to the <MAC> Res Req Message
US_session_ID	32	To be copied to the <MAC> Res Req Message
DS_binding_valid	8	Validity flag of the next 10 fields
DS_session_control_field		
INA_client_source_IP_add	32	To be copied to the <MAC> Res Req Message
INA_client_destination_IP_add	32	To be copied to the <MAC> Res Req Message
INA_client_source_port	16	To be copied to the <MAC> Res Req Message
INA_client_destination_port	16	To be copied to the <MAC> Res Req Message
Downstream_transport_protocol	8	To be copied to the <MAC> Res Req Message
INA_client_source_MAC_add	48	To be copied to the <MAC> Res Req Message
INA_client_destination_MAC_add	48	To be copied to the <MAC> Res Req Message
DS_internet_protocol	16	To be copied to the <MAC> Res Req Message
DS_session_ID	32	To be copied to the <MAC> Res Req Message

This primitive is used by the upper layer to ask for new resource. The MAC layer will send a Resource Request message to the INA.

As specified in the Resource Request message definition, upper layer can ask for a new connection, or a new upstream capacity (fixed rate bandwidth or a reservation id), or a connection release.

The final answer to this request shall be either a MAC\_CONNECT\_IND, or a MAC\_RSV\_ID\_IND, or a MAC\_RELEASE\_IND or a MAC\_RESOURCE\_DENIED\_IND.

**Connect\_Id:** Is the identifier of the connection, if it exists. If the connection is for packet cable application, the number is the gate number associated with the connection (even if the connection does not exist).

**Resource\_Type:** Type of Resource requested:

Bit field

**bit 0** (0x01): a reservation id

**bit 1** (0x02): a new connection in fixed rate mode

**bit 2** (0x04): a new connection in cyclic fixed rate mode

**bit 3** (0x08): upgrade bandwidth of an existing connection

**bit 4** (0x10): release of an existing connection

**bits 5 to 8**: reserved (must be set to 0)

**US\_Bandwidth**: Requested bandwidth for Fixed rate mode, unit is slots/1200 mS.

**Slot\_distance**: When cyclic assignment is required, maximum distance between the slots, unit is in slots.

**Encapsulation**: Type of encapsulation requested. Corresponds to the same field in the Connect Message (i.e. Direct\_IP, Ethernet\_Mac\_Bridging, PPP).

### B.1.1.7 <Prim>MAC\_RESOURCE\_CNF

Parameter	Format	Comment
Primitive_id	16	0x0807
Res_Req_Id	8	Identifier of the Resource Request

After reception of a MAC\_RESOURCE\_REQ, the MAC layer sends the Resource Request message to the INA, it creates an identifier and indicates it to the upper layer in order to identify the subsequent answer.

**Res\_Req\_Id**: The identifier of the last MAC\_RESOURCE\_REQ received by the MAC.

### B.1.1.8 <Prim>MAC\_RESOURCE\_DENIED\_IND

Parameter	Format	Comment
Primitive_id	16	0x0808
Res_Req_Id	8	Identifier of the Resource Request

This primitive indicates the reception of a Resource Denied Message, it is received after a Resource Request that has been refused by the INA.

**Res\_Req\_Id**: The identifier of a previous Resource Request that has been denied by the INA.

## B.1.2 On INA side

### B.1.2.1 <Prim> MAC\_INA\_RESOURCE\_REQ

Parameter	Format	Comment
Primitive_ID	16	0x0811
Primitive_Request_ID	16	Identifies the Primitive Request
MAC_address	48	MAC address of the NIU to which a new connection is requested.
Connect_ID	32	Connection identifier; 0 or packet cable gate ID for a new connection
Resource_Type	8	Type of Resource requested
US_Bandwidth	32	Upstream Bandwidth requested
Slot_distance	16	Maximum Distance between slots in upstream requested
Frame_length	16	The frame length for fixed rate connections
Encapsulation	8	Type of encapsulation requested. Corresponds to the same field in the Connect Message (i.e. Direct_IP, Ethernet_Mac_Bridging, PPP).
Priority_valid	8	Validity flag of the next field
Priority	8	To be copied to the corresponding <MAC> Message
DS_Flowspec_valid		Validity flag of the next 3 fields
Max_packet_size	16	To be copied to the corresponding <MAC> Message
Average_bitrate	16	To be copied to the corresponding <MAC> Message
Jitter	8	To be copied to the corresponding <MAC> Message
US_binding_valid	8	Validity flag of the next 10 fields
US_session_control_field	32	Control field for the US session binding
NIU_client_source_IP_add	32	To be copied to the corresponding <MAC> Message
NIU_client_destination_IP_add	32	To be copied to the corresponding <MAC> Message
NIU_client_source_port	16	To be copied to the corresponding <MAC> Message
NIU_client_destination_port	16	To be copied to the corresponding <MAC> Message
Upstream_transport_protocol	8	To be copied to the corresponding <MAC> Message
NIU_client_source_MAC_add	48	To be copied to the corresponding <MAC> Message
NIU_client_destination_MAC_add	48	To be copied to the corresponding <MAC> Message
US_internet_protocol	16	To be copied to the <MAC> Res Req Message
US_session_ID	32	To be copied to the <MAC> Res Req Message
DS_binding_valid	8	Validity flag of the next 10 fields
DS_session_control_field	32	Control field for th DS session binding
INA_client_source_IP_add	32	To be copied to the corresponding <MAC> Message
INA_client_destination_IP_add	32	To be copied to the corresponding <MAC> Message
INA_client_source_port	16	To be copied to the corresponding <MAC> Message
INA_client_destination_port	16	To be copied to the corresponding <MAC> Message
Downstream_transport_protocol	8	To be copied to the corresponding <MAC> Message
INA_client_source_MAC_add	48	To be copied to the corresponding <MAC> Message
INA_client_destination_MAC_add	48	To be copied to the corresponding <MAC> Message
DS_internet_protocol	16	To be copied to the <MAC> Res Req Message
DS_session_ID	32	To be copied to the <MAC> Res Req Message

This primitive is used by the upper layer to ask for a new resource. The upper layer can ask for a new connection, for the modification of an existing connection (e.g. fixed rate bandwidth or a reservation id), or for a connection release. The answer to this request shall be a <Prim> MAC\_INA\_RESOURCE\_IND.

#### Primitive\_Request\_ID:

**MAC\_address:** MAC address of the NIU concerned by this request.

**Connect\_Id:** Is the identifier of the connection, if it exists.

**Resource\_Type:** Type of Resource requested:

Bit field

**bit 0** (0x01): a reservation id

**bit 1** (0x02): a new connection in fixed rate mode

**bit 2** (0x04): a new connection in cyclic fixed rate mode

**bit 3** (0x08): upgrade bandwidth of an existing connection

**bit 4** (0x10): release an existing connection

**bits 5 to 8:** reserved (must be set to 0)

**US\_Bandwidth:** Requested bandwidth for Fixed rate mode, unit is slots/1 200 mS.

**Slot\_distance:** When cyclic assignment is required, maximum distance between the slots, unit is in slots.

**US\_Frame\_length:** The upstream frame length (slots), as given in the connect message, for fixed rate connections.

**Encapsulation:** Type of encapsulation requested. Corresponds to the same field in the Connect Message (i.e. Direct\_IP, Ethernet\_Mac\_Bridging, PPP).

### B.1.2.2 <Prim> MAC\_INA\_RESOURCE\_IND

Parameter	Format	Comment
Primitive_ID	16	0x0812
Primitive_Request_ID	16	Identifies the Primitive Request; 0 if not requested by the STU/Headend Network Adapter
Connect_Id	32	Connection identifier
Resource_Type	8	Type of Resource allocated
Error_Code	32	Specifies the type of error, if happened; zero for no error
US_Bandwidth	32	Upstream Bandwidth allocated
Slot_distance	16	Maximum Distance between slots in upstream assigned
Frame_length	16	The frame length in slots, for fixed rate connections
Encapsulation	8	Type of encapsulation assigned. Corresponds to the same field in the Connect message (i.e. Direct_IP, Ethernet_Mac_Bridging, PPP).
Priority_valid	8	Validity flag of the next field
Priority	8	Copy of the corresponding <MAC> Message
DS_Flowspec_valid		Validity flag of the next 3 fields
Max_packet_size	16	Copy of the corresponding <MAC> Message
Average_bitrate	16	Copy of the corresponding <MAC> Message
Jitter	8	Copy of the corresponding <MAC> Message
US_binding_valid	8	Validity flag of the next 10 fields
US_session_control_field	32	Control field for US session binding
NIU_client_source_IP_add	32	Copy of the corresponding <MAC> Message
NIU_client_destination_IP_add	32	Copy of the corresponding <MAC> Message
NIU_client_source_port	16	Copy of the corresponding <MAC> Message
NIU_client_destination_port	16	Copy of the corresponding <MAC> Message
Upstream_transport_protocol	8	Copy of the corresponding <MAC> Message
NIU_client_source_MAC_add	48	Copy of the corresponding <MAC> Message
NIU_client_destination_MAC_add	48	Copy of the corresponding <MAC> Message
US_internet_protocol	16	To be copied to the <MAC> Res Req Message
US_session_ID	32	To be copied to the <MAC> Res Req Message
DS_binding_valid	8	Validity flag of the next 10 fields
DS_session_control_field	32	Control field for DS session binding
INA_client_source_IP_add	32	Copy of the corresponding <MAC> Message
INA_client_destination_IP_add	32	Copy of the corresponding <MAC> Message
INA_client_source_port	16	Copy of the corresponding <MAC> Message
INA_client_destination_port	16	Copy of the corresponding <MAC> Message
Downstream_protocol	8	Copy of the corresponding <MAC> Message
INA_client_source_MAC_add	48	Copy of the corresponding <MAC> Message
INA_client_destination_MAC_add	48	Copy of the corresponding <MAC> Message
DS_internet_protocol	16	To be copied to the <MAC> Res Req Message
DS_session_ID	32	To be copied to the <MAC> Res Req Message

This primitive indicates that the MAC layer has changed or released an existing connection or established a new connection. The connection is either:

- the Default Connection (Connect Message sent by the INA just after the Initialization Complete message);
- a subsequent Connect message;
- an answer to a Resource Request previously sent by the CM/STB (see Resource Request primitive);
- an indication of a change in the connection characteristics after reception of a Re provisioning message.

**Primitive\_Request\_ID:**

**Connect\_Id:** Is the identifier of the connection, if it exists

**Resource\_Type:** Type of Resource requested:

Bit field

**bit 0** (0x01): a reservation id

**bit 1** (0x02): a new connection in fixed rate mode

**bit 2** (0x04): a new connection in cyclic fixed rate mode

**bit 3** (0x08): upgrade bandwidth of an existing connection

**bit 4** (0x10): release an existing connection

**bits 5 to 8:** reserved (must be set to 0)

**Error\_Code:** If not Null, the primitive is an answer to a previous MAC\_Resource\_REQ, and the request failed. The Error\_Code value correspond to the problem (TBD)

If value is 0, the Resource has been successfully set.

**DS\_Bandwidth:** Downstream Bandwidth requested. Unit t.b.d.

**DS\_Jitter:** Max. jitter in downstream requested. Unit t.b.d.

**US\_Bandwidth:** Requested bandwidth for Fixed rate mode, unit is slots/1 200 mS.

**Slot\_distance:** When cyclic assignment is required, maximum distance between the slots, unit is in slots.

**Encapsulation:** Type of encapsulation requested. Corresponds to the same field in the Connect Message (i.e. Direct\_IP, Ethernet\_Mac\_Bridging, PPP).

**User\_Port\_valid:** Validity flag of the next parameter ( 0 means invalid parameter).

**User\_Port\_ID:** Low latency Telephone port id

**Add\_Port\_Type:** Bit field that specifies TCP/UDP Port number and IP address validity:

**bit 0:** next IP address fields are valid

**bit 1:** next Port nb fields are valid and are TCP port

**bit 2:** next Port nb fields are valid and are UDP port

**bits 3 to 7:** Reserved (must be set to 0)

## B.2 Data Primitives

In this clause, two sets of primitives are presented. The first one at the Data Link level, the second at the MAC level. **One, and only one of them has to be used**, the choice will depend on the CM/STB or INA respective implementations.

The **DL\_** primitives serie is related to implementations where the MAC DVB-RC entity insures also the LLC function, (in that case, it is in fact a Data Link layer).

- In OOB, it consists in AAL5 reassembly and datagram recomposition following the encapsulation mode of the connection (i.e. Direct IP, Ethernet MAC bridging, PPP). The unit data are the datagrams.
- In IB, it consists in the MPE protocol filtering before datagram recomposition as in OOB.

The **MAC\_** primitives serie is intended to be used in systems where the MAC entity uses its native SDU as interface with the upper layer.

- In OOB, the ATM cells are the unit data exchanged.
- In IB, the downstream data unit is the payloads of the MPEG2\_TS frame, the upstream data unit is the ATM cells.

### B.2.1 <Prim> DL\_DATA\_IND

Parameter	Format	Comment
Primitive_ID	16	0x1001
Connect_ID	32	Connection identifier
Length	16	Length of the data buffer contained in the primitive
Data buffer	8[Length]	Received Datagram

This primitive is used to transfer the application data filtered by the MAC layer. The Connection identifier can be used to multiplex more efficiently the buffer when several connections exist.

### B.2.2 <Prim> DL\_DATA\_REQ

Parameter	Format	Comment
Primitive_ID	16	0x1002
Connect_ID	32	Connection identifier
Length	16	Length of the data buffer contained in the primitive
Data buffer	8[Length]	Datagram to be transmitted

The MAC layer is asked to transmit a network layer datagram. It will insure the segmentation function (and will use, in the NIU case, the upstream transmission mode of the connection).

### B.2.3 <Prim> MAC\_DATA\_IND

Parameter	Format	Comment
Primitive_ID	16	0x0001
Connect_ID	32	Connection identifier
Data_Type	8	Type of Data (ATM cells or MPEG packets)
Data_Unit_Nb	8	Number of ATM cells/MPEG packets contained in the primitive
Data_Unit_list	8[Unit Nb]	List of ATM Cells/MPEG packets

In OOB, when ATM cells whose VP/VC correspond to the value sent in a previous Connect Message, the MAC layer will then extract them from the physical frames and transfer to the application using this primitive. The broadcast VP/VC will also be taken into account.

In IB, the MAC layer filters the PID of the application, then extract the payload and passes it to the upper layer.

## B.2.4 <Prim> MAC\_DATA\_REQ

Parameter	Format	Comment
Primitive_ID	16	0x0002
Connect_ID	32	Connection identifier
Content_retry_count	8	Number of retries in Contention mode
US_mode (NIU only)	8	Mode of Upstream transmission
ATM_Cells_Nb	8	Number of ATM cells/MPEG packets contained in the primitive
ATM_Cells_List	8[ATM_Nb]	List of ATM Cells/MPEG packets

The upper layer asks the MAC layer to transmit messages. The data is formatted as a variable list of ATM cells/MPEG packets.

In case of the NIU, the MAC layer is able to execute the transmission in the three modes defined by ETS 300 800 [24]. It is mentioned by the upper layer in the parameter US\_mode that can take the following values:

**Contention mode:** As the ATM cells are transmitted in Contention region slots, each upstream packet must be acknowledged by the INA before the MAC layer sends the next one. If one acknowledgement is negative, the MAC layer will send it back "Contention\_retry\_count" times before stopping the transmission and indicating the error thanks to the MAC\_DATA\_CONF primitive.

**Reservation mode:** Before sending the upper layer message, the MAC layer must ask for reserved slots by sending a Reservation Request message to the INA. When the reserved slots are allocated (Grant message), the MAC layer uses these slots to transmit the application message. Another case of reservation mode occurs when the upper layer asks for transmission in Contention mode, and the number of ATM cells exceeds the number of ATM cells permitted in Contention mode.

**Fixed Rate mode:** In this mode, the upper layer asks the MAC layer to use the Fixed Rate slots allocated to the connection.

## B.2.5 <Prim> MAC\_DATA\_CONF

Parameter	Format	Comment
Primitive_ID	16	0x0003
Connect_ID	32	Connection identifier
Result	32	Success or reason of the failure. A value of 0 means the success of the previous Datat Request, any other value will be used to indicate the reason of the failure (as mentionned below)
Data_Unit_Nb	8	Number of ATM cells/MPEG packets effectively transmitted
US_mode (NIU only)	8	The transmission mode effectively used

This primitive is sent as an answer to a previous MAC\_DATA\_REQ.

The Result parameter specifies the result of its execution. It can take the following values:

- "OK": The transmission succeeded.
- "Contention\_Error": (NIU only) Contention\_retry\_count slots have not been acknowledged (in Contention mode), the transmission has stopped.
- "Reservation\_Failure": (NIU only) The reservation request did not succeed (no answer from the INA to the request).
- "Reservation\_Abort": (NIU only) Reservation request can be answered by several consecutive Grant messages, the sum of slots allocated in the successive Grant messages must then be equal to the requested number. This error occurs when Grant messages do not complete the number of slots in a pre-defined time-out.
- "Mode\_Not\_Permitted": (NIU only) If the application wants to use a transmission mode not allowed to this connection.

- "Unknown\_Error": Error not identified.

## B.3 Example MAC Control Scenarios

### B.3.1 Example MAC Control Scenario on STB/CM Side

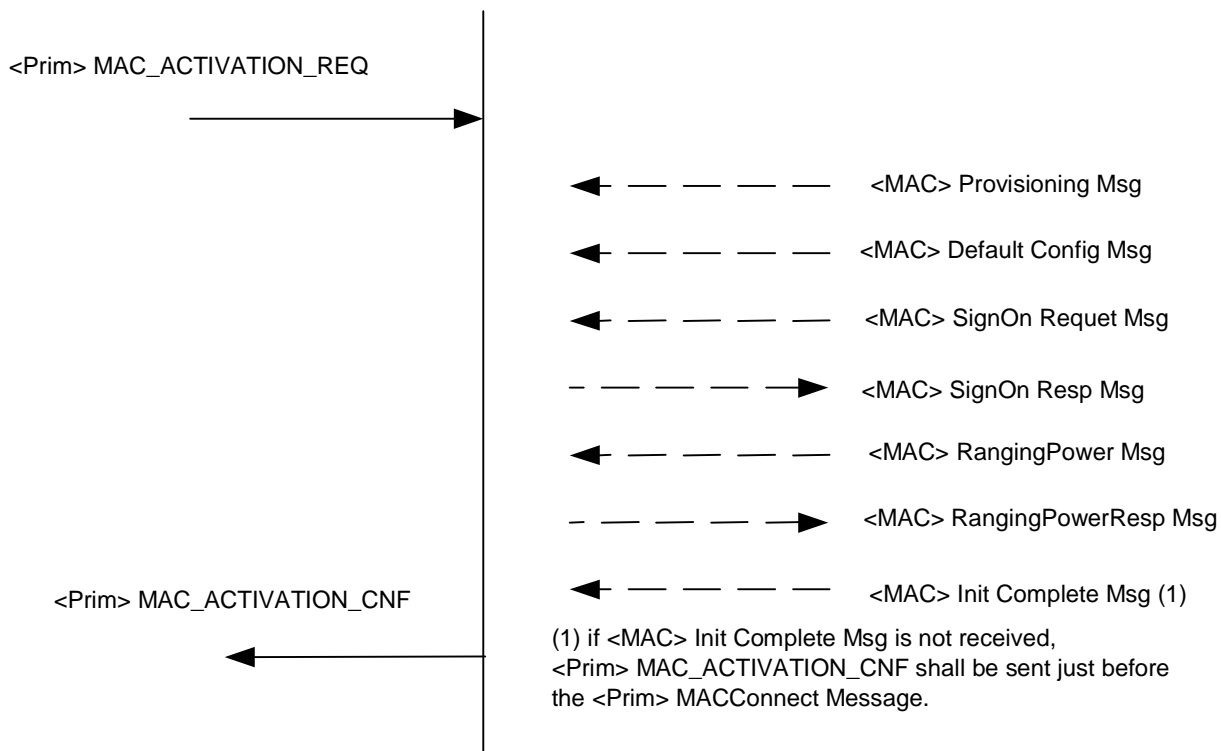



### B.3.2 Example Resource Management Scenario on STB/CM Side

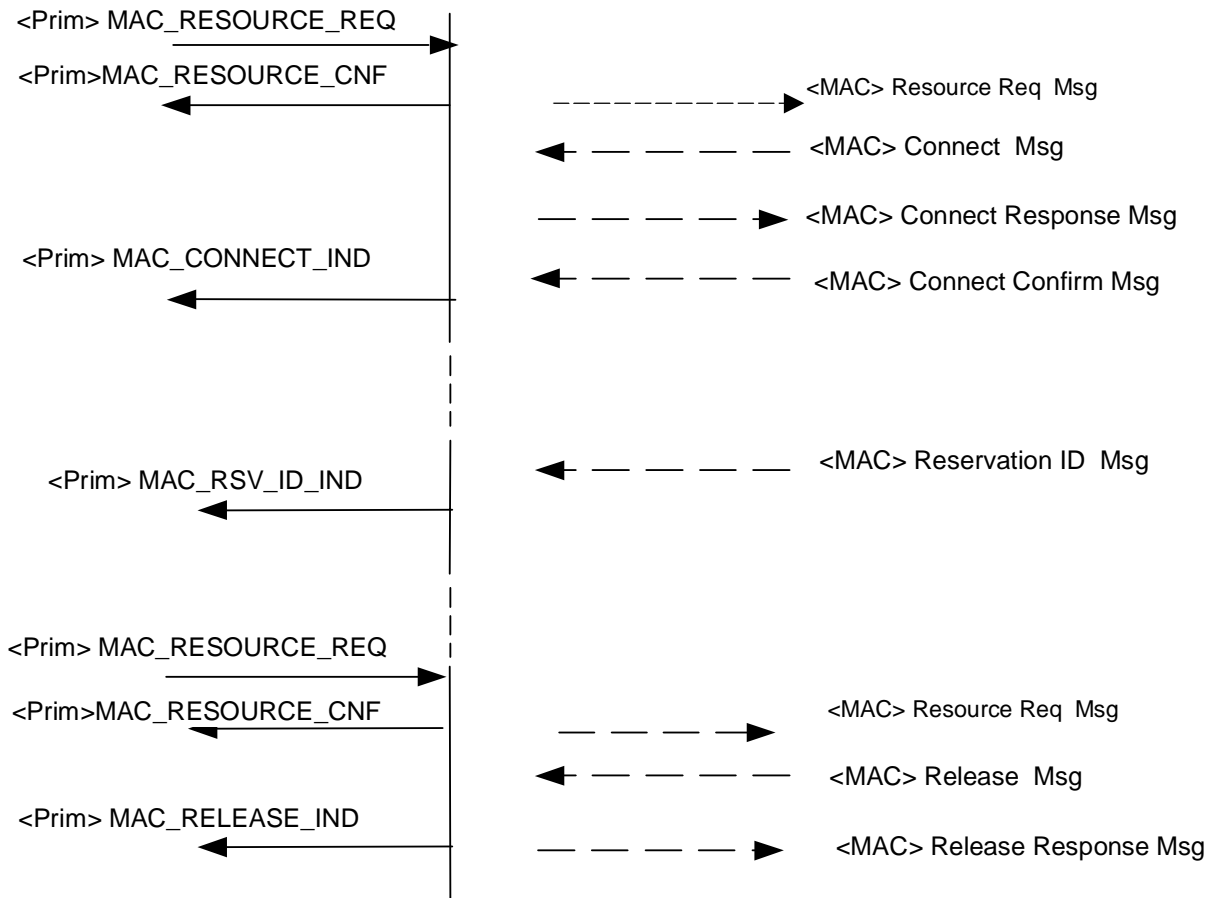

### B.3.3 Example Resource Management Scenario on INA Side

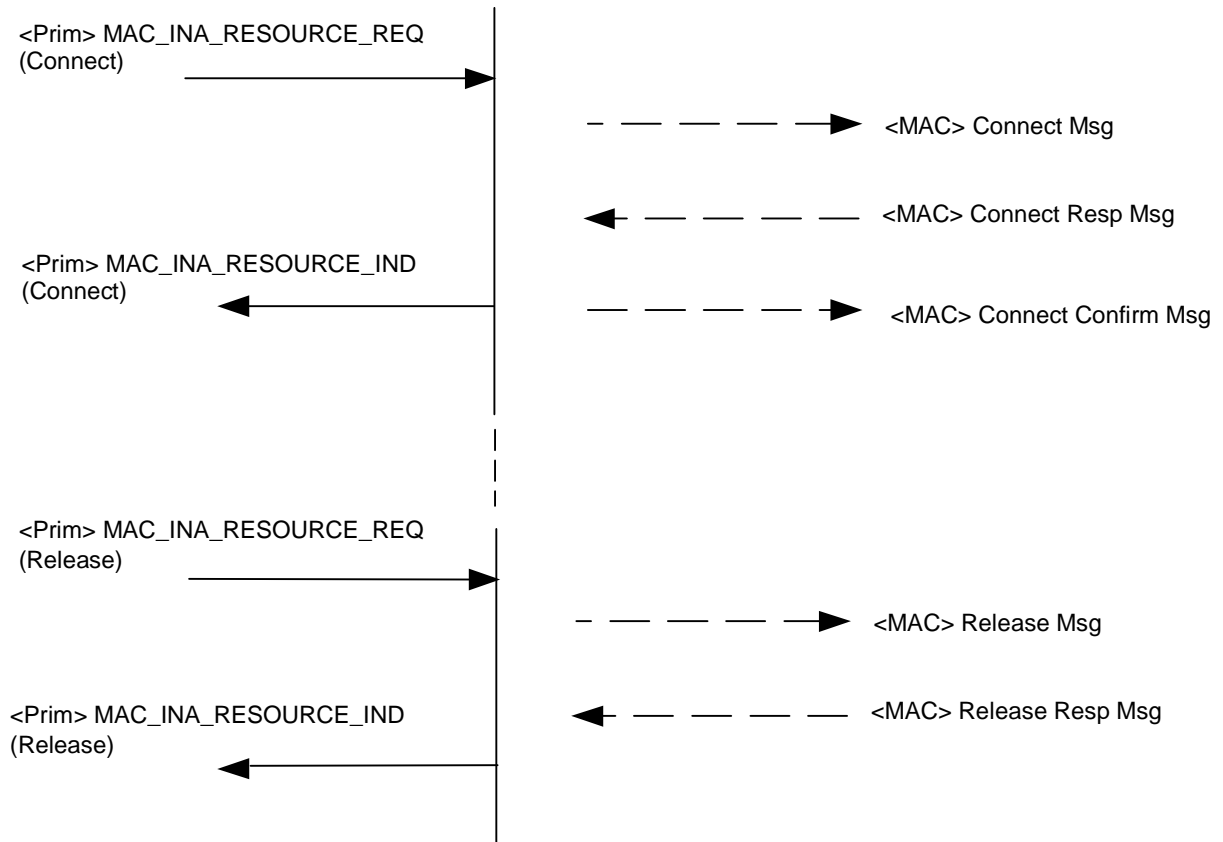

### B.3.4 Example Upstream Data Transfer Scenarios

#### Contention mode

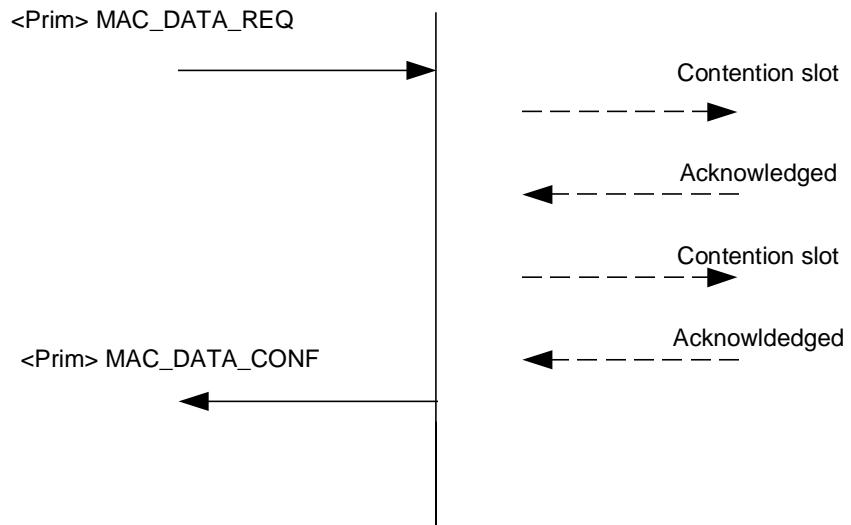

#### Fixed rate mode

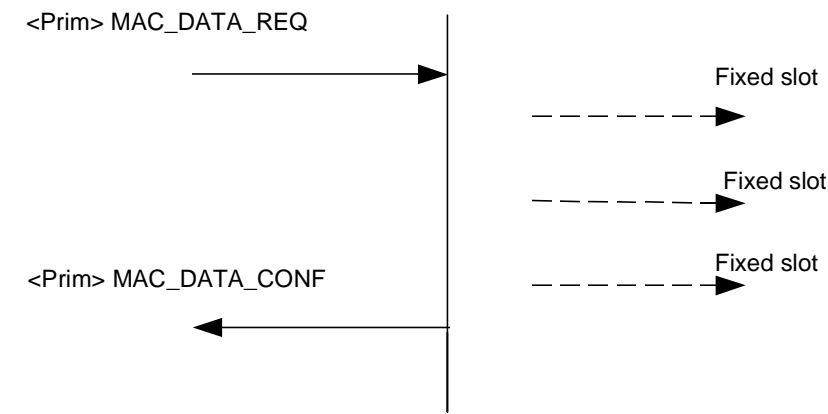

#### Reservation mode

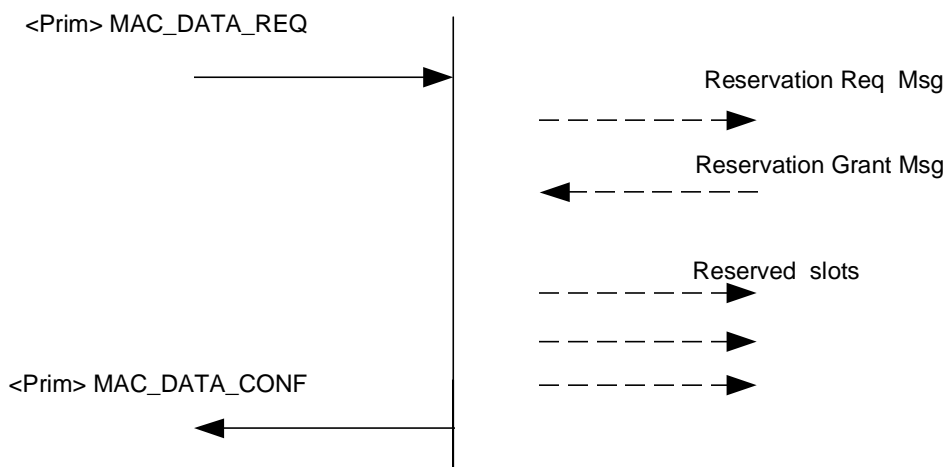

---

## Annex C (informative): Bibliography

[A] DVB-A008 (October 1995): "Commercial requirements for asymmetric interactive services supporting broadcast to the home with narrowband return channels".

[B] DAVIC 1.5 Specification: "DAVIC System Reference Model".

[C] 91/263/EEC: "Directive on Terminal equipment".

ITU-T Recommendation V.21 (1984): "300 bits per second duplex modem standardized for use in the general switched telephone network".

ITU-T Recommendation V.22 (1988): "1200 bits per second duplex modem standardized for use in the general switched telephone network and on point-to-point 2-wire leased telephone-type circuits".

IUT-T Recommendation V.22bis (1988): "2 400 bits per second duplex modem using the frequency division technique standardized for use on the general switched telephone network and on point-to-point 2-wire leased telephone-type circuits".

ITU-T Recommendation V.23 (1988): "600/1200-baud modem standardized for use in the general switched telephone network".

ITU-T Recommendation V.25 (1996): "Automatic answering equipment and general procedures for automatic calling equipment on the general switched telephone network including procedures for disabling of echo control devices for both manually and automatically established calls".

ITU-T Recommendation V.32 (1993): "A family of 2-wire, duplex modems operating at data signalling rates of up to 9600 bit/s for use on the general switched telephone network and on leased telephone-type circuits".

ITU-T Recommendation V.32bis (1991): "A duplex modem operating at data signalling rates of up to 14 400 bit/s for use on the general switched telephone network and on leased point-to-point 2-wire telephone-type circuits".

ITU-T Recommendation V.34 (1998): "A modem operating at data signalling rates of up to 33 600 bit/s for use on the general switched telephone network and on leased point-to-point 2-wire telephone-type circuits".

ITU-T Recommendation V.42 (1996): "Error-correcting procedures for DCEs using asynchronous-to-synchronous conversion".

EN 50201 (1998): "Interfaces for DVB-IRDs".

ETSI ETS 300 802: "Digital Video Broadcasting (DVB); Network-independent protocols for DVB interactive services".

EN 50083: "Cabled Distribution Systems for television and sound signals".

ETSI EN 300 421: "Digital Video Broadcasting (DVB); Framing structure, channel coding and modulation for 11/12 GHz satellite services".

---

## History

<b>Document history</b>		
Edition 1	July 1998	Publication as ETS 300 800
V1.2.1	April 2000	Publication
V1.3.1	August 2001	Membership Approval Procedure      MV 20011026: 2001-08-28 to 2001-10-26