

ETSI EN 305 174-1 V1.1.1 (2018-02)



**Access, Terminals, Transmission and Multiplexing (ATTM);
Broadband Deployment and Lifecycle Resource Management;
Part 1: Overview, common and generic aspects**

Reference

REN/ATTM-009

Keywordsbroadband, energy management, ICT,
sustainability**ETSI**

650 Route des Lucioles
F-06921 Sophia Antipolis Cedex - FRANCE

Tel.: +33 4 92 94 42 00 Fax: +33 4 93 65 47 16

Siret N° 348 623 562 00017 - NAF 742 C
Association à but non lucratif enregistrée à la
Sous-Préfecture de Grasse (06) N° 7803/88

Important notice

The present document can be downloaded from:

<http://www.etsi.org/standards-search>

The present document may be made available in electronic versions and/or in print. The content of any electronic and/or print versions of the present document shall not be modified without the prior written authorization of ETSI. In case of any existing or perceived difference in contents between such versions and/or in print, the only prevailing document is the print of the Portable Document Format (PDF) version kept on a specific network drive within ETSI Secretariat.

Users of the present document should be aware that the document may be subject to revision or change of status.

Information on the current status of this and other ETSI documents is available at

<https://portal.etsi.org/TB/ETSIDeliverableStatus.aspx>

If you find errors in the present document, please send your comment to one of the following services:

<https://portal.etsi.org/People/CommiteeSupportStaff.aspx>

Copyright Notification

No part may be reproduced or utilized in any form or by any means, electronic or mechanical, including photocopying and microfilm except as authorized by written permission of ETSI.

The content of the PDF version shall not be modified without the written authorization of ETSI.

The copyright and the foregoing restriction extend to reproduction in all media.

© ETSI 2018.

All rights reserved.

DECT™, **PLUGTESTS™**, **UMTS™** and the ETSI logo are trademarks of ETSI registered for the benefit of its Members.

3GPP™ and **LTE™** are trademarks of ETSI registered for the benefit of its Members and of the 3GPP Organizational Partners.

oneM2M logo is protected for the benefit of its Members.

GSM® and the GSM logo are trademarks registered and owned by the GSM Association.

Contents

Intellectual Property Rights	5
Foreword.....	5
Modal verbs terminology.....	6
Introduction	7
1 Scope	8
2 References	8
2.1 Normative references	8
2.2 Informative references.....	8
3 Definitions and abbreviations.....	9
3.1 Definitions.....	9
3.2 Abbreviations	11
4 Network sub-systems of broadband infrastructure.....	11
4.1 General	11
4.1.1 Network schematics.....	11
4.1.2 Energy management	12
4.2 ICT sites	13
4.2.1 General.....	13
4.2.2 Operator Site (OS).....	14
4.2.3 Network Data Centre (NDC).....	14
4.3 Network Distribution Nodes (NDNs).....	15
4.4 Core networks	15
4.5 Access networks.....	15
4.5.1 Fixed (broadband) access networks.....	15
4.5.2 Mobile (broadband) access networks.....	16
4.5.3 Cable access networks	17
4.6 Customer premises	17
4.6.1 General.....	17
4.6.2 Homes (single-tenant).....	18
4.6.3 Office premises (single-tenant).....	18
4.6.4 Multi-tenant premises (residential or commercial).....	19
5 Format of other standards in the ETSI EN 305 174 series	19
Annex A (informative): History of network schematics.....	20
Annex B (informative): Future structure of this multi-part deliverable.....	21
History	22

List of figures

Figure 1: Updated schematic of fixed and mobile communication networks	12
Figure 2: Network sub-systems of fixed broadband access network infrastructure	13
Figure 3: Network sub-systems of mobile broadband access network infrastructure	14
Figure 4: Fixed access network implementations.....	15
Figure 5: Access network technology options.....	16
Figure 6: Mobile access network technology options	16
Figure 7: Customer premises served by the cable operator access networks	17
Figure 8: Customer premises served by the fixed access networks.....	18
Figure A.1: Schematic of fixed and mobile communication networks (June 2011).....	20

Intellectual Property Rights

Essential patents

IPRs essential or potentially essential to normative deliverables may have been declared to ETSI. The information pertaining to these essential IPRs, if any, is publicly available for **ETSI members and non-members**, and can be found in ETSI SR 000 314: "*Intellectual Property Rights (IPRs); Essential, or potentially Essential, IPRs notified to ETSI in respect of ETSI standards*", which is available from the ETSI Secretariat. Latest updates are available on the ETSI Web server (<https://ipr.etsi.org/>).

Pursuant to the ETSI IPR Policy, no investigation, including IPR searches, has been carried out by ETSI. No guarantee can be given as to the existence of other IPRs not referenced in ETSI SR 000 314 (or the updates on the ETSI Web server) which are, or may be, or may become, essential to the present document.

Trademarks

The present document may include trademarks and/or tradenames which are asserted and/or registered by their owners. ETSI claims no ownership of these except for any which are indicated as being the property of ETSI, and conveys no right to use or reproduce any trademark and/or tradename. Mention of those trademarks in the present document does not constitute an endorsement by ETSI of products, services or organizations associated with those trademarks.

Foreword

This European Standard (EN) has been produced by ETSI Technical Committee Access, Terminals, Transmission and Multiplexing (ATTM).

The present document is part 1 of a multi-part deliverable covering lifecycle resource management of broadband deployment as identified below:

ETSI EN 305 174-1: "Overview, common and generic aspects";

ETSI EN 305 174-2: "ICT Sites";

ETSI TS 105 174-4: "Access Networks";

ETSI EN 305 174-5: "Customer network infrastructures";

ETSI TS 105 174-6: "Cable Access Networks";

ETSI TS 105 174-7: "Digital multiservice cities";

ETSI EN 305 174-8: "Management of end of life of ICT equipment (ICT waste / end of life)".

Other documents are planned for development to extend this multi-part deliverable. These are listed in annex B and are mentioned in the present document.

National transposition dates	
Date of adoption of this EN:	22 February 2018
Date of latest announcement of this EN (doa):	31 May 2018
Date of latest publication of new National Standard or endorsement of this EN (dop/e):	30 November 2018
Date of withdrawal of any conflicting National Standard (dow):	30 November 2018

Modal verbs terminology

In the present document "**shall**", "**shall not**", "**should**", "**should not**", "**may**", "**need not**", "**will**", "**will not**", "**can**" and "**cannot**" are to be interpreted as described in clause 3.2 of the [ETSI Drafting Rules](#) (Verbal forms for the expression of provisions).

"**must**" and "**must not**" are **NOT** allowed in ETSI deliverables except when used in direct citation.

Introduction

The increasing interaction between the different elements of the Information Communication Technology (ICT) sector (hardware, middleware, software and services) supports the concept of convergence in which:

- multi-service packages can be delivered over a common infrastructure;
- a variety of infrastructures is able to deliver these packages;
- a single multi-service-package may be delivered over different infrastructures.

As a result of this convergence, the development of new services, applications and content has resulted in:

- an increased demand for bandwidth, reliability, quality and performance, with a consequent increase in the demand for power which has implications for cost and, in some cases, availability;
- an associated continuous evolution of ICT equipment.

It is therefore important to consider the environmental viability of all network elements necessary to deliver the required services in terms of the management of their operational aspects i.e. energy management (including energy efficiency) and the management of the End-of-Life (EoL) of the ICT equipment.

NOTE: The term "environmental viability" is used while recognizing that well established treatments of "sustainability" feature three separate viability objectives (environmental, economic and social). For the purposes of this multi-part deliverable, only operational aspects of environmental viability are considered. A wider approach to environmental viability takes other factors into account including the use of raw materials and avoidance of hazardous substances in the construction of infrastructure or ICT equipment- these factors are not considered.

New technologies and infrastructure strategies are expected to enable operators to decrease the energy consumption, for a given level of service, of their existing and future infrastructures thus decreasing their costs. This requires a common understanding among market participants that only standards can produce.

This multi-part deliverable specifies the general engineering of various broadband infrastructures to enable the most effective energy management (and management of other resources) and the appropriate measures for EoL treatment of ICT equipment. Certain of the standards may specify requirements for interoperability.

The present document is part 1 of a multi-part deliverable and provides an overview of the standards series together with a definition of the common and generic aspects to which the other standards in the series conform.

The present document been produced by ETSI Technical Committees Access, Terminals, Transmission and Multiplexing (ATTM) and Cable in close collaboration with CENELEC via the Installations and Cabling Co-ordination Group (ICCG).

1 Scope

The present document is part 1 of a multi-part deliverable which specifies the general engineering of various broadband infrastructures to enable the most effective energy management (and management of other resources) and the appropriate measures for End-of-Life (EoL) treatment of ICT equipment.

This multi-part deliverable does not address the following aspects of the broadband network sub-systems:

- implications for carbon "footprint";
- resources used to construct the sub-systems;
- the nature or method of production of the energy consumed by the infrastructures.

The present document provides an overview of the ETSI EN 305 174 series of standards together with a definition of the common and generic aspects to which the other standards in the series conform.

Clause 2 and clause 3 contain references, definitions, symbols and abbreviations which relate to this part; similar information will be included in the corresponding clauses of the other parts, thus ensuring that each document can be used on a "stand-alone" basis.

Clause 4 describes the network sub-systems applicable to broadband infrastructures and their interconnections that are addressed by the ETSI EN 305 174 series.

Clause 5 specifies the format of the other parts of the ETSI EN 305 174 series (other than ETSI EN 305 174-8 [i.6]).

2 References

2.1 Normative references

References are either specific (identified by date of publication and/or edition number or version number) or non-specific. For specific references, only the cited version applies. For non-specific references, the latest version of the referenced document (including any amendments) applies.

Referenced documents which are not found to be publicly available in the expected location might be found at <https://docbox.etsi.org/Reference/>.

NOTE: While any hyperlinks included in this clause were valid at the time of publication, ETSI cannot guarantee their long term validity.

The following referenced documents are necessary for the application of the present document.

Not applicable.

2.2 Informative references

References are either specific (identified by date of publication and/or edition number or version number) or non-specific. For specific references, only the cited version applies. For non-specific references, the latest version of the referenced document (including any amendments) applies.

NOTE: While any hyperlinks included in this clause were valid at the time of publication, ETSI cannot guarantee their long term validity.

The following referenced documents are not necessary for the application of the present document but they assist the user with regard to a particular subject area.

- [i.1] Recommendation ITU-T I.113: "Series I: Integrated services digital network: General structure - Terminology: Vocabulary of terms for broadband aspects".

- [i.2] CENELEC EN 50700:2014: "Information technology - Premises distribution access network (PDAN) cabling to support deployment of optical broadband networks".
- [i.3] CENELEC EN 50174-3:2013: "Information technology - Cabling installation - Part 3: Installation planning and practices outside buildings".
- [i.4] ETSI EN 305 174-2: "Access, Terminals, Transmission and Multiplexing (ATTM); Broadband Deployment and Lifecycle Resource Management; Part 2: ICT Sites".
- [i.5] ETSI EN 305 174-5-1: "Access, Terminals, Transmission and Multiplexing (ATTM); Broadband Deployment and Lifecycle Resource Management; Part 5: Customer network infrastructures; Sub-part 1: Homes (single-tenant)".
- [i.6] ETSI EN 305 174-8: "Access, Terminals, Transmission and Multiplexing (ATTM); Broadband Deployment and Lifecycle Resource Management; Part 8: Management of end of life of ICT equipment (ICT waste / end of life)".
- [i.7] Mandate M/462: "Standardisation mandate addressed to CEN, CENELEC and ETSI in the field of ICT to enable efficient energy use in fixed and mobile information and communication networks".

3 Definitions and abbreviations

3.1 Definitions

For the purposes of the present document, the following terms and definitions apply:

access network: functional elements (that is equipment and infrastructure) that enable communication between an operator site (OS) and a customer network

access provider: operator or other entity providing the means to enable external telecommunications service provision to a subscriber

NOTE: Source: CENELEC EN 50700:2014 [i.2] and CENELEC EN 50174-3:2013 [i.3].

Base Station (BS): network telecommunications equipment which serves one or more cells within a coverage area of a mobile network

base station site: Network Distribution Node (NDN) which accommodates a base station

broadband: telecommunications service capable of providing more than 2 048 kbit/s (Recommendation ITU-T I.113 [i.1]) full-rate capacity in at least one direction

NOTE: ISDN is not considered to be a broadband technology and is not addressed in the present document.

cable access network: access network provided by cable operators comprising optical fibre and metallic cabling providing direct connection to customer premises

core network: functional elements (that is equipment and infrastructure) that enable communication between operator sites (OSs) or equivalent ICT sites

customer network: functional elements (that is equipment and infrastructure) that enable communication between a network interface unit (NIU), network termination point (NTP) or external network interface (ENTI), as appropriate, and one or more pieces of terminal equipment (TE)

Customer Premises (CP): any location which is the sole responsibility of the customer

End-of-Life (EoL): established point in a product life cycle after a period of primary use and at which a decision is required with regard to reuse, recycling or disposal

end-use IT equipment: terminal equipment (TE) of a fixed access network, user equipment (UE) of a mobile access network or network interface unit (NIU) of a cable access network

External Network Test Interface (ENTDI): point in or near the customer premises (inside or outside the customer network) accessible to the fixed access network operator for testing purposes

Fibre Node (FN): device which performs a media conversion between an optical fibre cable link and a coaxial cable link in a cable access network

fixed access network: access network provided by telecommunications operators comprising optical fibre and metallic cabling providing direct connection to customer premises

ICT equipment: equipment providing data storage, processing and transport services

NOTE: A combination of Information Technology Equipment and Network Telecommunications Equipment.

ICT site: site containing structures or group of structures dedicated to the accommodation, interconnection and operation of ICT equipment together with all the facilities and infrastructures for power distribution and environmental control together with the necessary levels of resilience and security required to provide the desired service availability

Information Technology Equipment (ITE): equipment providing data storage, processing and transport services for subsequent distribution by network telecommunications equipment (NTE)

Last Operators Connection point (LOC): interface to the fixed access transport networks of one or more operators from which cabling is routed to a customer network

mobile access network: telecommunications network in which the access to the network (connection between user equipment and network) is implemented over the air interface

Network Data Centre (NDC): data centre embedded within the core network

NOTE: A network data centre of a cable access network may be termed a master head-end.

Network Distribution Node (NDN): grouping of NTE equipment within the boundaries of an access network providing distribution of service from an operator site (OS)

NOTE: Where all the Network Telecommunications Equipment (NTE) at a given location is under common governance, any supporting infrastructure for power distribution and environmental control together with the necessary levels of resilience and security required to provide the desired service availability is included as part of the NDN.

Network Interface Unit (NIU): principal device within customer premises allowing user access to the services provided by the cable access network

Network Telecommunications Equipment (NTE): equipment between the boundaries of, and dedicated to providing connection to, core and/or access networks

Network Termination Point (NTP): physical point(s) at which a subscriber is provided with access to the operator network (this may be co-located with an external network test interface)

Operator Site (OS): premises accommodating network telecommunications equipment (NTE) providing direct connection to the core and access networks and which may also accommodate information technology equipment (ITE)

NOTE 1: An operator site that is only connected to the core network is considered as a network data centre.

NOTE 2: An operator site of a cable access network may be termed a local head-end.

service provider: operator of any service that furnishes telecommunications content (transmissions) delivered over access provider facilities

NOTE 1: The access provider and the service provider can be a single entity.

NOTE 2: Source: CENELEC EN 50700:2014 [i.2] and CENELEC EN 50174-3:2013 [i.3].

subscriber: identifiable entity within the premises that requires or may require a direct connection to the access network

Terminal Equipment (TE): principal device within customer premises allowing user access to the services provided by the fixed access network

User Equipment (UE): device allowing user access to the services provided by the mobile access network

3.2 Abbreviations

For the purposes of the present document, the following abbreviations apply:

ATTM	Access, Terminals, Transmission and Multiplexing
BS	Base Station
CENELEC	European Committee for Electrotechnical Standardization
CP	Customer Premises
ENTI	External Network Test Interface
EoL	End-of-Life
FN	Fibre Node
FTTB	Fibre To The Building
FTTC	Fibre To The Cabinet
FTTH	Fibre To The Home
HFC	Hybrid optical Fibre-Coaxial
ICCG	CENELEC/ETSI Installations and Cabling Co-ordination Group
ICT	Information Communications Technology
IT	Information Technology
KPI	Key Performance Indicator
LOC	Last Operators Connection point
NDC	Network Data Centre
NDN	Network Distribution Node
NIU	Network Interface Unit
NTE	Network Telecommunications Equipment
NTP	Network Termination Point
OS	Operator Site
R	Repeater
TE	Terminal Equipment
UE	User Equipment

4 Network sub-systems of broadband infrastructure

4.1 General

4.1.1 Network schematics

The network schematic used in the present document is shown in Figure 1. This has been updated since the original schematic included in the initial response to the Mandate M/462 [i.7]. The original schematic and details of the changes are listed in annex A.

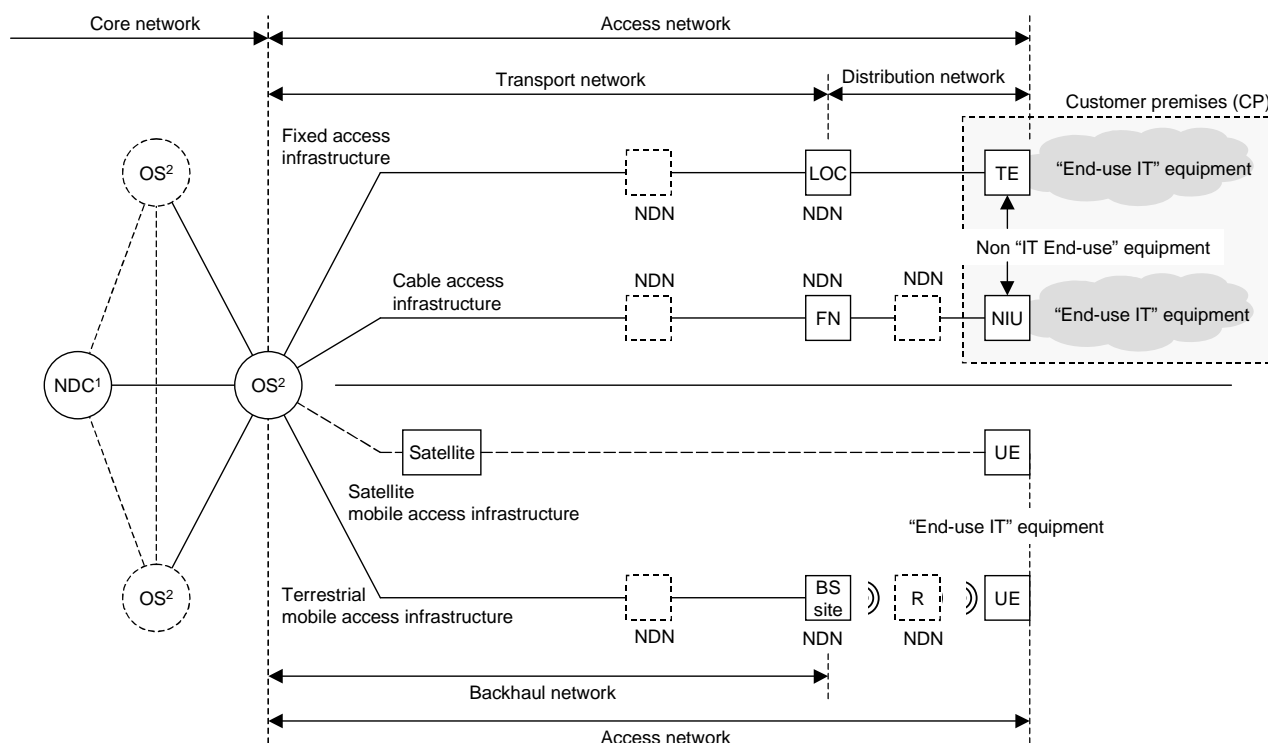

¹ For cable access networks this is termed "Master head-end/OS"

² For cable access networks this is termed "Local head-end/OS"

Figure 1: Updated schematic of fixed and mobile communication networks

The customer premises may take a number of forms. As detailed in clause 4.4 the subscriber may be residential or commercial and may be within single-tenanted or multi-tenanted premises. It is also necessary to distinguish between the access provider, who is responsible for the design, operation and maintenance of the access network, and the service provider that provides the service carried to the subscriber by the access network. These two entities may be different. A given access network may support multiple service providers.

4.1.2 Energy management

Broadband provision is an enabling technology capable of supporting a reduction of global energy consumption (for example, by providing facilities such as home working and video conferencing to reduce travel demands). For this reason, it may not be the case that the total energy consumption of broadband networks will be reduced, though the application of effective energy efficiency measures will minimize any increases due to predicted service evolution.

The scale of reductions in energy consumption and/or improvements of energy efficiency is:

- dependent on the network sub-systems;
- generally greater at the design stage rather than following improvements to existing infrastructures.

The potential reductions in energy consumption and/or improvements of energy efficiency in ICT sites as described in clause 4.2 are expected to be substantial but apply in only a relatively small number of locations and may prove vital where availability of power is restricted. These clearly defined premises are provided with appropriate Key Performance Indicators (KPIs) to determine relative performance levels in terms of energy efficiency.

By comparison to ICT sites the saving at the various network distribution nodes and within the cabling infrastructures of the individual access networks may be very much smaller but the aggregation of those saving may outweigh the energy efficiency gains elsewhere due to the very large number of customers, thus justifying their consideration and implementation. The communities served by customer networks are the recipients of the "energy efficiency enabling" technologies provided by broadband services and the relevant parts of this multi-part deliverable serves to indicate strategies/approaches that maximize the opportunities presented.

Within customer premises, it is generally the customer rather than the operator that funds the energy costs. Potential reductions in energy consumption may well be identifiable in design terms but they are generally not individually quantifiable due to the diversity of customer networks.

In addition to the procedures for the energy management, the ETSI EN 305 174 series standards also include requirements and recommendations for the End-of-Life (EoL) management of the ICT equipment.

4.2 ICT sites

4.2.1 General

ETSI EN 305 174-2 [i.4] specifies the requirements for resource management of ICT sites as a combination of:

- energy management (i.e. energy consumption and task efficiency);
- EoL management of ICT equipment by reference to ETSI EN 305 174-8 [i.6].

The requirements of ETSI EN 305 174-2 [i.4] address the following ICT sites:

- Operator Site (OS);
- Network Data Centre (NDC).

The OS accommodates the Network Telecommunication Equipment (NTE) that provides connection to the access and core networks - and is typically under control of the access provider. The NDC which provides the telecommunication service content may be under the separate control of the service provider(s). The requirements of ETSI EN 305 174-2 [i.4] do not differentiate between the two. It should be noted that an OS that is only connected to the core network is considered to be an NDC.

Figure 2 is a technology-agnostic diagram depicting a segment of a broadband network showing the interconnection of ICT sites comprising OSs and NDCs with customer premises installations for fixed access networks. In principle, every operator network can contain any number of each of these elements and may be connected to any number of other operator networks.

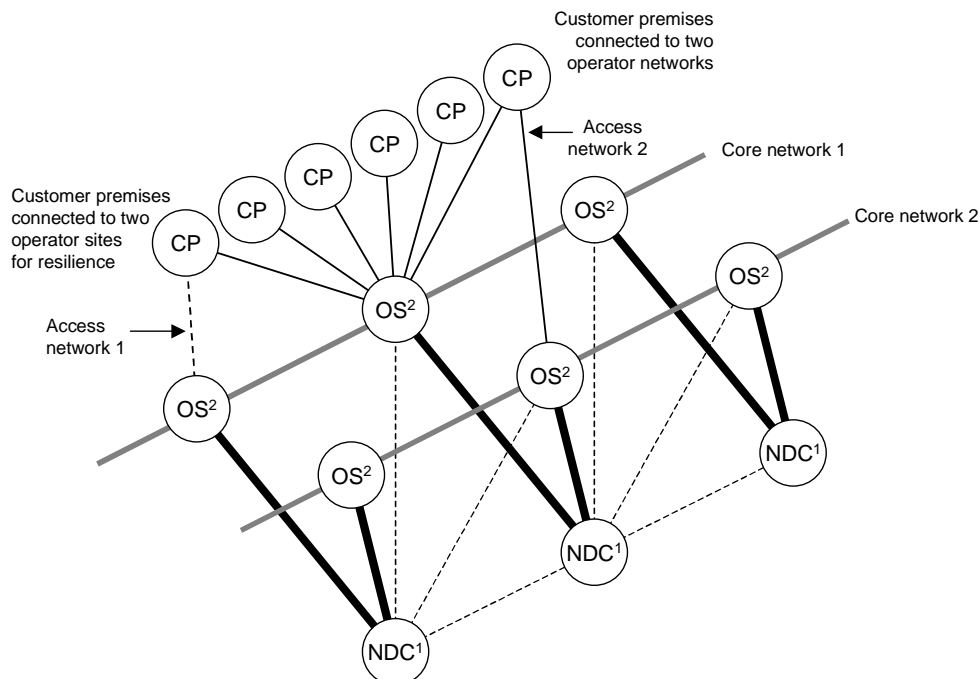

¹ For cable access networks this is termed "Master head-end/OS"

² For cable access networks this is termed "Local head-end/OS"

Figure 2: Network sub-systems of fixed broadband access network infrastructure

Figure 3 is a technology-agnostic diagram depicting a segment of a broadband network showing the interconnection of ICT sites and Base Stations (BS) for mobile access networks. Each BS may provide services to a variable number of "end-use IT equipments" shown as user equipment (UE) in Figure 3.

In principle, every operator network can contain any number of each of these elements and may be connected to any number of other operator networks.

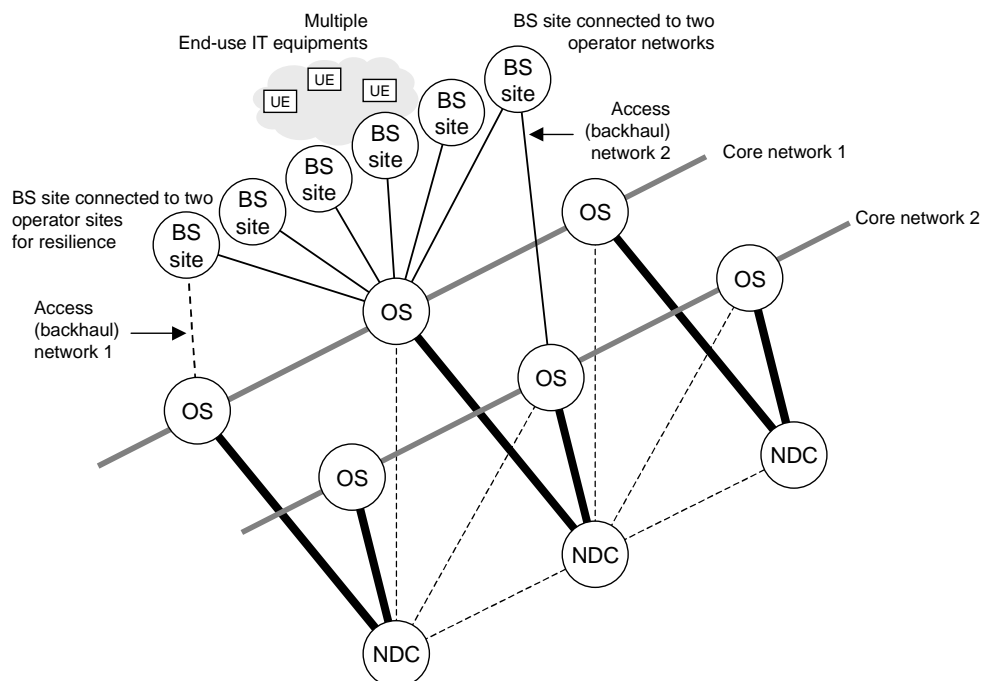

Figure 3: Network sub-systems of mobile broadband access network infrastructure

4.2.2 Operator Site (OS)

NOTE: This is equivalent to the master head-end for a cable access network.

With reference to Figure 2 and Figure 3 an OS is the network sub-system in the core network that enables the connectivity between network data centres and customer premises over which the required services can be delivered, using the access network. An OS also enables indirect connectivity between customer premises. An OS will almost invariably each serve many thousands of customer connections. Each customer connection may be comprised of multiple communication paths and serve a variety of applications.

4.2.3 Network Data Centre (NDC)

NOTE 1: This is equivalent to the local head-end for a cable access network.

With reference to Figure 2 and Figure 3 an NDC is a network sub-system serving the core network of one or more operators. Its functions include the storage, processing and dissemination of data as required to fulfil customer expectations, the hosting of the necessary applications, content hosting, etc.

To enable their functionality, each NDC shall be connected to at least one core network OS. For reasons of network resilience, an NDC will invariably be connected to more than one OS and to several other NDCs. An NDC may serve core networks operated by several network operators, thus enabling traffic between customers of different network operators.

NOTE 2: This description of an NDC excludes any locations containing servers and their related hardware that are used required solely for administrative functions such as customer management functions, billing, etc.

4.3 Network Distribution Nodes (NDNs)

The Network Distribution Nodes (NDNs) within the access network, are an essential design element and are typically under the control of the access provider.

The requirements and recommendations for the NDNs of the various access networks are addressed within the ETSI EN 305 174 series covering the relevant access network.

4.4 Core networks

A future ETSI EN 305 174-3, as described in annex B, specifies the requirements for resource management of core networks as a combination of:

- energy management (i.e. energy consumption and task efficiency);
- EoL management of ICT equipment by reference to ETSI EN 305 174-8 [i.6].

4.5 Access networks

4.5.1 Fixed (broadband) access networks

A future ETSI EN 305 174-4-1, as described in annex B, specifies the requirements for resource management of fixed access networks as a combination of:

- energy management (i.e. energy consumption and task efficiency);
- EoL management of ICT equipment by reference to ETSI EN 305 174-8 [i.6].

Figure 4 shows the fixed access network implementations addressed in ETSI EN 305 174-4-1. NDNs within "dashed" boxes are optional.

The configurations of the external network test interface (ENTI) and network termination point (NTP) are described in clause 4.6.

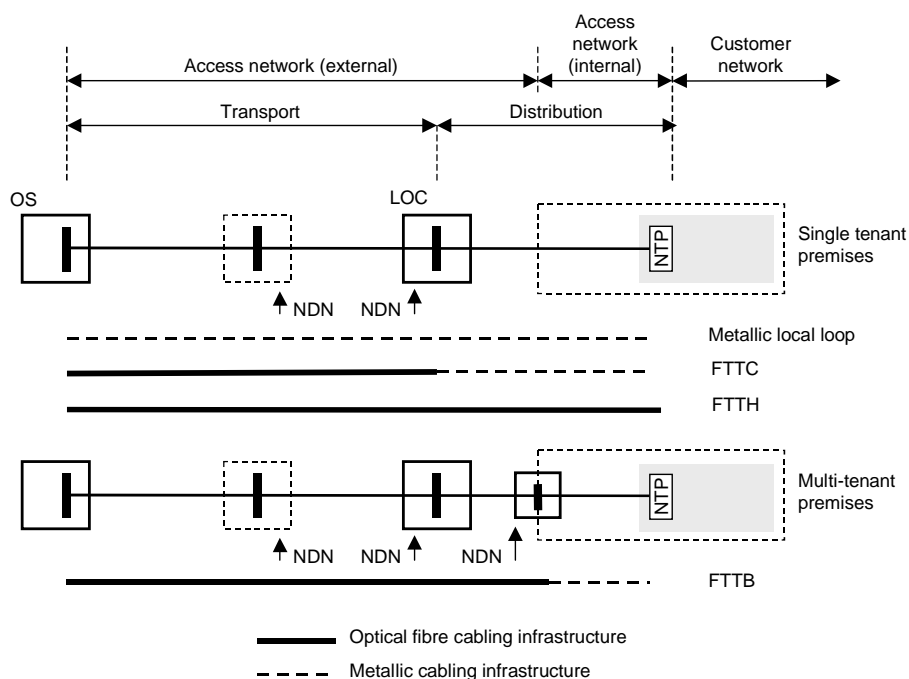

NOTE: Dotted line indicates metallic (balanced or coaxial) cabling.

Figure 4: Fixed access network implementations

Figure 5 shows the detailed implementations of Figure 4 which are addressed in ETSI EN 305 174-4-1.

The transmission media addressed comprise optical fibre cabling, balanced and coaxial metallic cabling.

A future ETSI EN 305 174-4-1 addresses "point-to-point" networks in all transmission media. Where the access network adopts a transport infrastructure implemented using optical fibre, the supported distribution infrastructures are:

- all supported media for point-to-point systems;
- optical fibre only for point-to-point (virtual) systems;
- optical fibre only for point-to-multi-point (passive) systems;
- optical fibre only for point-to-multi-point (virtual and passive) systems.

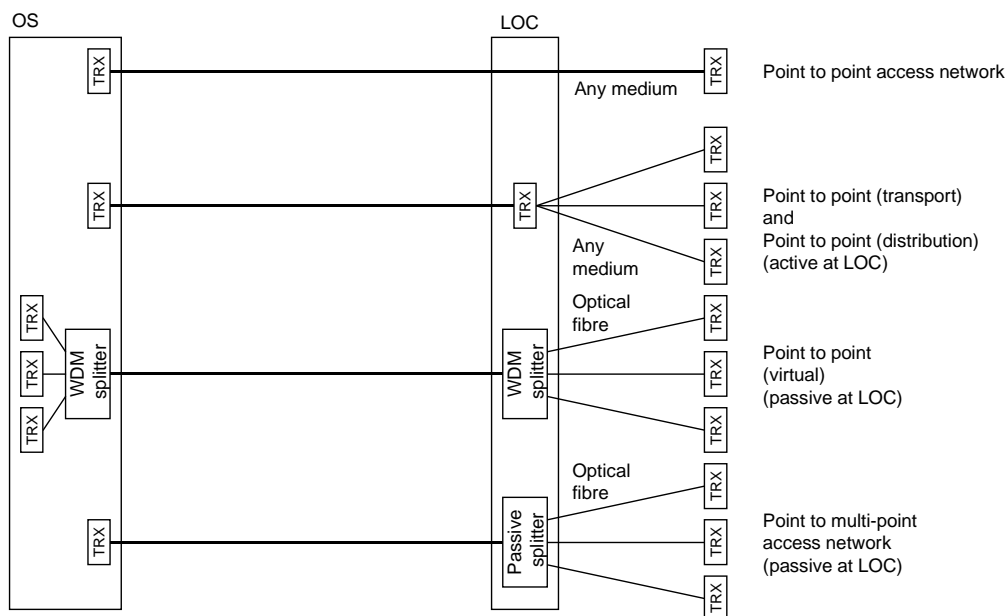

Figure 5: Access network technology options

4.5.2 Mobile (broadband) access networks

A future ETSI EN 305 174-4-2, as described in annex B, specifies the requirements for resource management of mobile access networks as a combination of:

- energy management (i.e. energy consumption and task efficiency);
- EoL management of ICT equipment by reference to ETSI EN 305 174-8 [i.6].

Figure 6 shows options for mobile access network implementations. NDNs within "dashed" boxes are optional.

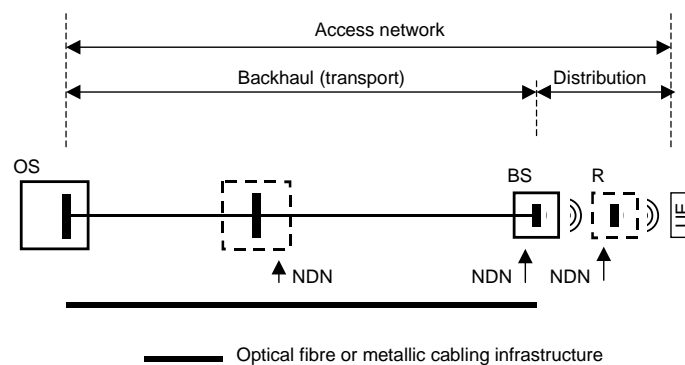

Figure 6: Mobile access network technology options

The energy consumption of the UE is outside the scope of Mandate M/462 [i.7] but the performance of the UE affects the energy management of the BS (and/or repeater (R)) and has to be taken into account in any analysis of the operational performance of the BS and the wider mobile broadband access network.

4.5.3 Cable access networks

A future ETSI EN 305 174-6, as described in annex B, specifies the requirements for resource management of Hybrid optical Fibre-Coaxial (HFC) cable access networks as a combination of:

- energy management (i.e. energy consumption and task efficiency);
- EoL management of ICT equipment by reference to ETSI EN 305 174-8 [i.6].

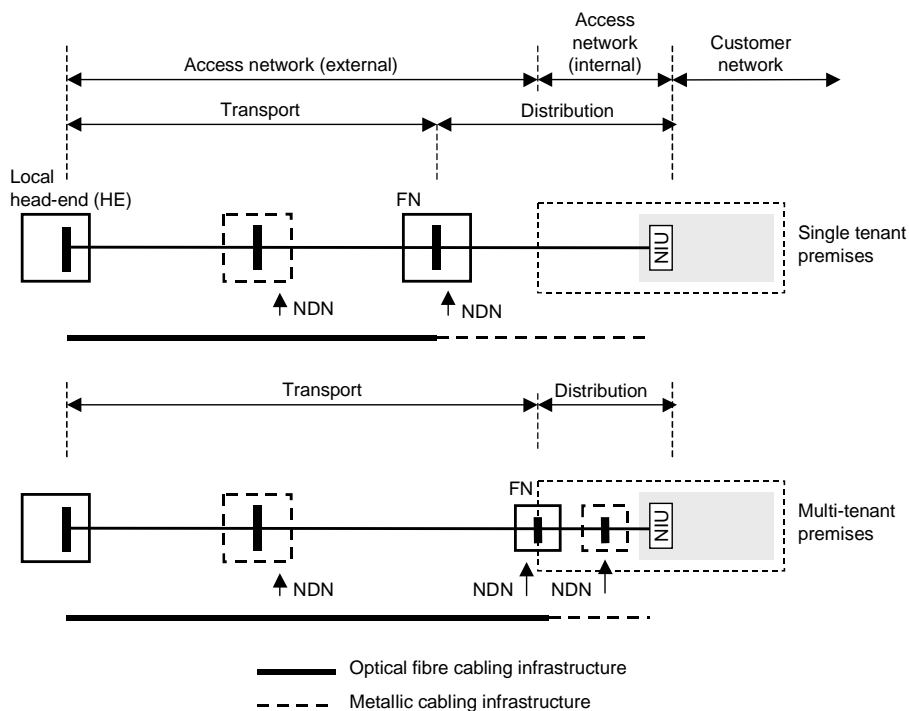

Figure 7: Customer premises served by the cable operator access networks

Figure 7 shows options for cable access network implementations. NDNs within "dashed" boxes are optional.

4.6 Customer premises

4.6.1 General

Both fixed access and cable access networks serve subscribers within customer premises. The customer premises are designated as either single-tenant or multi-tenant.

Figure 8 shows the types of premises served by the majority of access networks. Customer premises are connected to at least one OS in the core network and accommodate the terminal equipment required to provide those services to which the customer has chosen to subscribe, together with the local network equipment necessary to distribute those services within the customer network infrastructure.

Customer premises may be connected to two or more OSs on one or more core networks in order to provide the desired access network and/or service provider diversity.

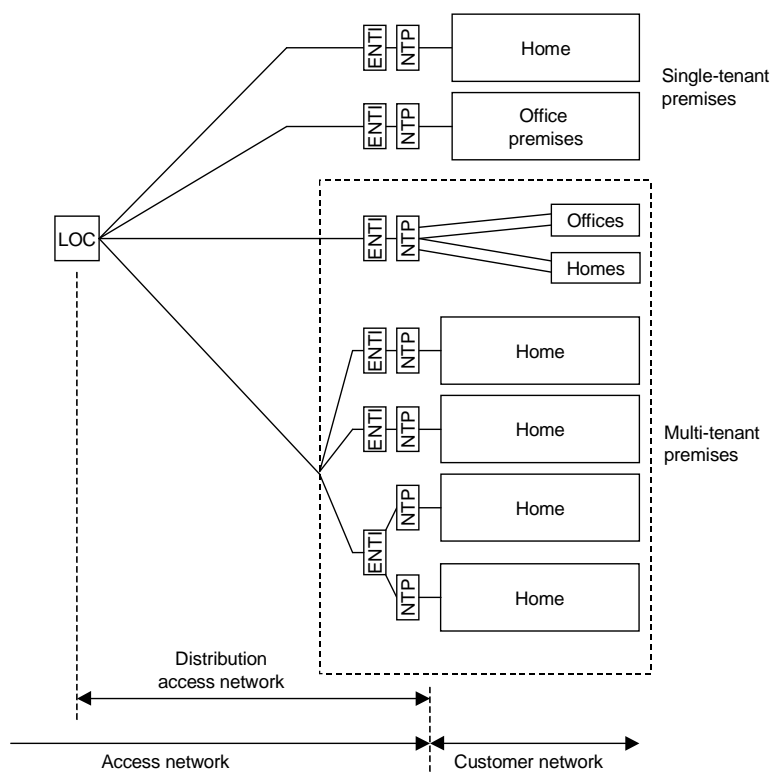

Figure 8: Customer premises served by the fixed access networks

4.6.2 Homes (single-tenant)

ETSI EN 305 174-5-1 [i.5] specifies the requirements for resource management of customer premises equipment in homes (single-tenant) as a combination of:

- energy management;
- EoL management of ICT equipment by reference to ETSI EN 305 174-8 [i.6].

Most single-tenant homes will be connected to a single access network as convergence allows the offerings of multiple service providers over that common infrastructure. However, it is not uncommon for multiple access networks to be provided to a single-tenant home. An example of such provision would be separate fixed access and cable access networks. The demand for high speed data in homes is expected to increase but the criticality of that provision is low since much of the increase is related to entertainment services.

4.6.3 Office premises (single-tenant)

A future ETSI EN 305 174-5-2, as described in annex B, specifies the requirements for resource management of customer premises equipment in office premises (single-tenant) as a combination of:

- energy management;
- EoL management of ICT equipment by reference to ETSI EN 305 174-8 [i.6].

Single-tenant premises include office (and other commercial and industrial premises) that will usually be equipped with their own customer premises distribution network.

Such premises vary significant in terms of size and complexity and may accommodate one or more data centres that are connected to at least one access network via one or more NTPs.

Single-tenant premises also include dedicated customer data centres which provide a private service to other customer premises via the access network(s) to which they are connected.

It should be noted that an ENTI for each of the access networks may be connected to more than one, service-specific NTP within the premises.

Businesses may demand high levels of service availability, independent of the amount of data transmitted. Such demands result in the connection of the customer premises to multiple OSs.

4.6.4 Multi-tenant premises (residential or commercial)

A future ETSI EN 305 174-5-4, as described in annex B, specifies the requirements for resource management of customer premises equipment in multi-tenant premises (residential or commercial) as a combination of:

- energy management;
- EoL management of ICT equipment by reference to ETSI EN 305 174-8 [i.6].

Multi-tenant premises can house homes and/or offices and in both cases can take two forms:

- a) one or more NTPs serve(s) each home or office within which there is a customer network;
- b) one or more NTPs serve(s) connects to a customer data centre from which services are distributed to each of the homes and/or offices via a third party - normally acting on behalf of the building owner. In such cases the customer network includes both the network within the individual homes and/or offices together with the building distribution network.

As detailed in clause 4.6.3 a given customer network may be serviced by a number of NTPs providing broadband delivery from a number of operator networks, thus providing resilience in the case of failure of one of the access networks. The reasons for this may be commercial or strategic (to provide resilience in the case of access network failure).

Multi-tenant premises, which may include a mix of residential and commercial subscribers, feature connection to an appropriate number of OSs based upon the levels of service availability required by the tenants and their type.

5 Format of other standards in the ETSI EN 305 174 series

The other standards in the ETSI EN 305 174 series (except for ETSI EN 305 174-8 [i.6]) shall adopt the following format:

- **Clause 4:** containing an introduction to the context of the element(s) of broadband infrastructure addressed by the specific part of the ETSI EN 305 174 series.
- **Clause 5:** containing a review of standardization applicable to the resource management of the element(s) of broadband infrastructure addressed by the specific part of the ETSI EN 305 174 series.
- **Clause 6:** containing the requirements of for resource management of the element(s) of broadband deployment addressed by the specific part of the ETSI EN 305 174 series which shall address:
 - 1) general design and operational engineering to support energy management where universal solutions are able to be defined - also addressing, where appropriate, interoperability;
 - 2) the application of KPIs to assess energy management trends;
 - 3) the treatment of EoL of ICT equipment via ETSI EN 305 174-8 [i.6].
- **Annexes** as required.

Annex A (informative): History of network schematics

The response of the European Standards Organizations (June 2011) to the European Commission in response to Mandate M/462 [i.7] (dealing with "efficient energy use in fixed and mobile information and communication networks") used Figure A.1 as an overall schematic to describe the fixed and mobile networks for the delivery of broadband services. Since that time the schematic has been subject to change and is replaced by Figure 1.

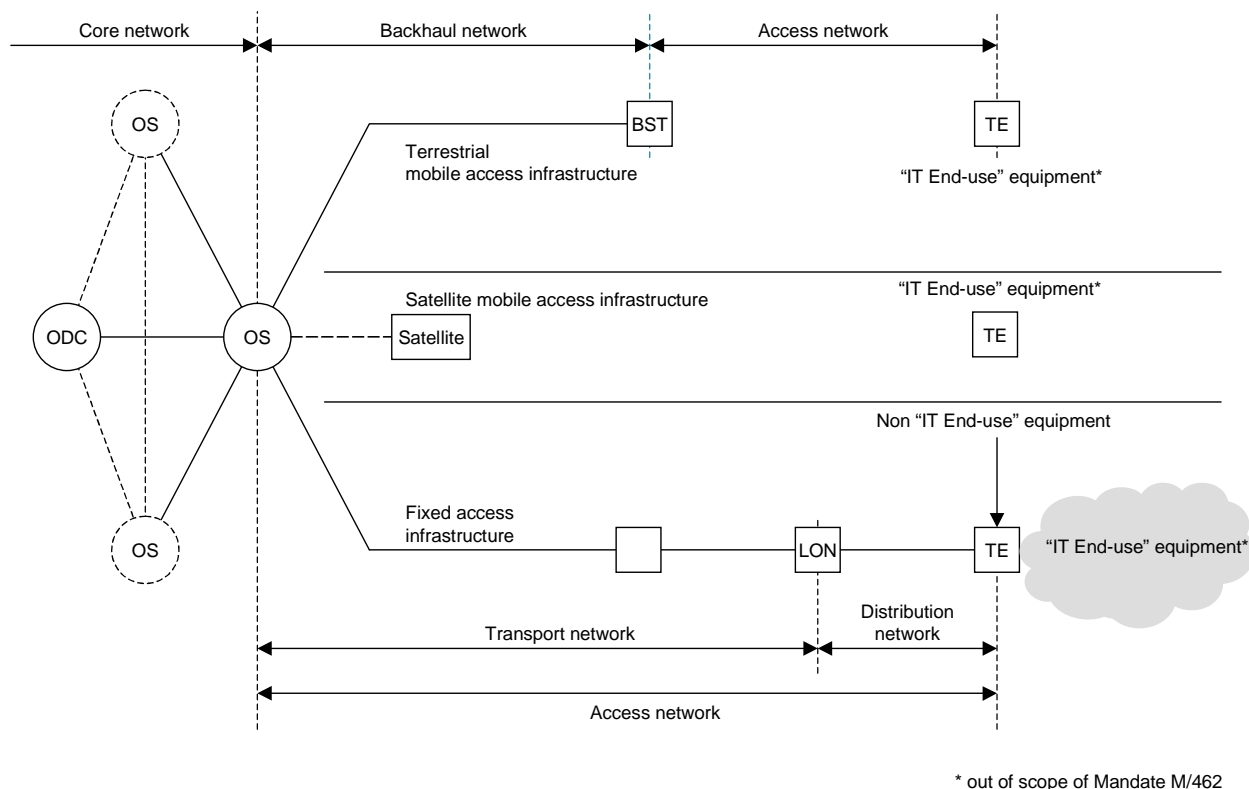

Figure A.1: Schematic of fixed and mobile communication networks (June 2011)

With reference to the differences between Figure A.1 and Figure 1 the following should be considered.

For all access networks, the operator data centre (ODC) has been replaced by a network data centre (NDC) and certain network distribution nodes (NDN) are shown within dashed boxes to indicate that they are optional.

Within the fixed access network, the term NDN is employed to describe a variety of aggregations of network telecommunications equipment (NTE) at locations between the operator site (OS) and the terminal equipment (TE). The last operator cabinet (LOC) is shown as a specific example of an NDN and has replaced the last operator node (LON). The other change for fixed access networks is that customer premises (CP) is shown.

Within the mobile access network, the term NDN is employed to describe a variety of aggregations of NTE at locations between the OS and the user equipment (UE) which has replaced the terminal equipment (TE). The base station (BS) site and repeater (R) are shown as specific examples of NDNs.

Within the satellite network UE has replaced TE.

Within the cable access network, the term NDN is employed to describe a variety of aggregations of NTE at locations between the local head-end (HE) and the network interface unit (NIU), which has replaced the TE. The fibre node (FN) is shown as specific example of an NDN. The other change for cable access networks is that customer premises (CP) is shown.

Annex B (informative): Future structure of this multi-part deliverable

The present document forms part of series of standards which are listed under Phase 2 of Mandate M/462 [i.7].

In addition to the documents listed in the Foreword, the series is intended to include the following:

ETSI EN 305 174-3: "Core, regional metropolitan networks";

ETSI EN 305 174-4: "Access Networks":

Sub-part 1: "Fixed access networks (excluding cable)";

Sub-part 2: "Mobile access networks";

ETSI EN 305 174-5: "Customer network infrastructures":

Sub-part 2: "Office premises (single-tenant)";

Sub-part 4: "Multi-tenant premises (residential and commercial)";

ETSI EN 305 174-6: "Cable Access Networks".

History

Document history		
V1.1.1	October 2009	Publication as ETSI TS 105 174-1
V1.2.1	September 2014	Publication as ETSI TS 105 174-1
V1.0.0	November 2017	EN Approval Procedure AP 20180222: 2017-11-24 to 2018-02-22
V1.1.1	February 2018	Publication