



**Short Range Devices (SRD)
and Ultra Wide Band (UWB);
Part 2: Measurement techniques
for receiver requirements**

ReferenceREN/ERM-TGUWB-619

Keywordsmeasurement, receiver, testing, UWB

ETSI650 Route des Lucioles
F-06921 Sophia Antipolis Cedex - FRANCE

Tel.: +33 4 92 94 42 00 Fax: +33 4 93 65 47 16

Siret N° 348 623 562 00017 - APE 7112B
Association à but non lucratif enregistrée à la
Sous-Préfecture de Grasse (06) N° w061004871

Important notice

The present document can be downloaded from:
<https://www.etsi.org/standards-search>

The present document may be made available in electronic versions and/or in print. The content of any electronic and/or print versions of the present document shall not be modified without the prior written authorization of ETSI. In case of any existing or perceived difference in contents between such versions and/or in print, the prevailing version of an ETSI deliverable is the one made publicly available in PDF format at www.etsi.org/deliver.

Users of the present document should be aware that the document may be subject to revision or change of status. Information on the current status of this and other ETSI documents is available at <https://portal.etsi.org/TB/ETSIDeliverableStatus.aspx>

If you find errors in the present document, please send your comment to one of the following services:
<https://portal.etsi.org/People/CommitteeSupportStaff.aspx>

If you find a security vulnerability in the present document, please report it through our Coordinated Vulnerability Disclosure Program:
<https://www.etsi.org/standards/coordinated-vulnerability-disclosure>

Notice of disclaimer & limitation of liability

The information provided in the present deliverable is directed solely to professionals who have the appropriate degree of experience to understand and interpret its content in accordance with generally accepted engineering or other professional standard and applicable regulations.

No recommendation as to products and services or vendors is made or should be implied. In no event shall ETSI be held liable for loss of profits or any other incidental or consequential damages.

Any software contained in this deliverable is provided "AS IS" with no warranties, express or implied, including but not limited to, the warranties of merchantability, fitness for a particular purpose and non-infringement of intellectual property rights and ETSI shall not be held liable in any event for any damages whatsoever (including, without limitation, damages for loss of profits, business interruption, loss of information, or any other pecuniary loss) arising out of or related to the use of or inability to use the software.

Copyright Notification

No part may be reproduced or utilized in any form or by any means, electronic or mechanical, including photocopying and microfilm except as authorized by written permission of ETSI.

The content of the PDF version shall not be modified without the written authorization of ETSI. The copyright and the foregoing restriction extend to reproduction in all media.

© ETSI 2024.
All rights reserved.

Contents

Intellectual Property Rights	6
Foreword.....	6
Modal verbs terminology.....	6
Introduction	7
1 Scope	8
2 References	8
2.1 Normative references	8
2.2 Informative references.....	8
3 Definition of terms, symbols and abbreviations.....	9
3.1 Terms.....	9
3.2 Symbols.....	10
3.3 Abbreviations	11
4 General	12
5 Receiver Requirements.....	12
5.1 General Guidance on RX measurement	12
5.2 Receiver Spurious Emissions	12
5.2.1 Description.....	12
5.2.2 Limits.....	12
5.2.3 Conformance.....	13
5.2.3.1 General	13
5.2.3.2 Step 1: Measurement with Peak Detector	13
5.2.3.3 Step 2: Measurement with Peak Detector and calculation RMS Value	14
5.3 Use-Case Specific Input Parameters for Receiver Baseline Requirements	15
5.3.1 Introduction.....	15
5.3.2 Wanted Technical Performance Criteria.....	15
5.3.3 Examples of Use-Case Specific Input Parameter for Receiver Tests	15
5.3.3.1 Communication/Location Tracking Device	15
5.3.3.2 Radio Determination Device (non-contact based)	16
5.3.3.3 Material contact-based radio determination device.....	18
5.4 Receiver Baseline Sensitivity (RBS).....	20
5.4.1 Description.....	20
5.4.2 Limits.....	20
5.4.3 Conformance.....	21
5.4.3.1 General	21
5.4.3.2 Conducted measurements for radio communication devices	21
5.4.3.2.0 General	21
5.4.3.2.1 Step 1: Wanted Technical Performance Criteria	21
5.4.3.2.2 Step 2: Sensitivity Requirement (Power)	21
5.4.3.2.3 Step 3: Measurement Procedure	21
5.4.3.2.4 Step 4: Wanted Technical Performance Criteria Assessment.....	23
5.4.3.3 Radiated Measurements for Radio Communication Devices with Power Limit.....	23
5.4.3.3.0 General	23
5.4.3.3.1 Step 1: Wanted Technical Performance Criteria	23
5.4.3.3.2 Step 2: Sensitivity Requirement (Power)	23
5.4.3.3.3 Step 3: Measurement Procedure	23
5.4.3.3.4 Step 4: Wanted Technical Performance Criteria Assessment.....	25
5.4.3.4 Radiated measurements for radio communication devices with distance limit.....	25
5.4.3.4.0 General	25
5.4.3.4.1 Step 1: Wanted Technical Performance Criteria	25
5.4.3.4.2 Step 2: Sensitivity Requirement (Distance).....	25
5.4.3.4.3 Step 3: Measurement Procedure	25
5.4.3.4.4 Step 4: Technical Wanted Performance Criteria Assessment.....	26
5.4.3.5 Radiated Measurements for Radiodetermination Applications with Distance Limit	26

5.4.3.5.0	General	26
5.4.3.5.1	Step 1: Technical Performance Criteria.....	26
5.4.3.5.2	Step 2: Sensitivity Requirement (Distance).....	27
5.4.3.5.3	Step 3: Measurement Procedure	27
5.4.3.5.4	Step 4: Wanted Technical Performance Criteria Assessment.....	28
5.4.3.6	Conducted measurements for radio determination devices	28
5.4.3.6.0	General	28
5.4.3.6.1	Step 1: Wanted Technical Performance Criteria	28
5.4.3.6.2	Step 2: Sensitivity Requirement (Power)	28
5.4.3.6.3	Step 3: Measurement Procedure	29
5.4.3.6.4	Step 4: Wanted Technical Performance Criteria Assessment.....	30
5.5	Receiver Baseline Resilience (RBR)	30
5.5.1	Description.....	30
5.5.2	RBR Requirements	30
5.5.2.1	Interferer test signal.....	30
5.5.2.2	RBR wanted performance criteria.....	30
5.5.3	Conformance.....	31
5.5.3.1	General	31
5.5.3.2	Conducted Measurements for Radio Communication Devices.....	31
5.5.3.2.1	Step 1: Start with the RBS Setup.....	31
5.5.3.2.2	Step 2: Adding Interfering Signal Source.....	31
5.5.3.2.3	Step 3: Degradation of Sensitivity Requirement	31
5.5.3.2.4	Step 4: Test of Wanted Technical Performance Criteria	31
5.5.3.2.5	Step 5: Measurement Assessment	32
5.5.3.2.6	Step 6: Repetition of steps 4 and 5	32
5.5.3.3	Radiated Measurements for Radio Communication Devices with Power Limit.....	32
5.5.3.3.1	Step 1: Start with the RBS Setup.....	32
5.5.3.3.2	Step 2: Adding Interfering Signal Source.....	32
5.5.3.3.3	Step 3: Degradation of Sensitivity Requirement	33
5.5.3.3.4	Step 4: Test of Wanted Technical Performance Criteria	33
5.5.3.3.5	Step 5: Measurement Assessment	33
5.5.3.3.6	Step 6: Repetition of steps 4 and 5	33
5.5.3.4	Radiated Measurements for Radio Communication Devices with Distance Limit	34
5.5.3.4.1	Step 1: Start with the RBS setup.....	34
5.5.3.4.2	Step 2: Adding interfering signal source	34
5.5.3.4.3	Step 3: Degradation of Sensitivity Requirement	35
5.5.3.4.4	Step 4: Test of Wanted Technical Performance Criteria	35
5.5.3.4.5	Step 5: Measurement Assessment	35
5.5.3.4.6	Step 6: Repetition of steps 4 and 5	35
5.5.3.5	Radiated Measurements for Radiodetermination Applications with Distance Limit	35
5.5.3.5.1	Step 1: Start with the RBS Setup.....	35
5.5.3.5.2	Step 2: Adding interfering signal source	35
5.5.3.5.3	Step 3: Degradation of Sensitivity Requirement	37
5.5.3.5.4	Step 4: Test of Wanted Technical Performance Criteria	37
5.5.3.5.5	Step 5: Measurement Assessment	37
5.5.3.5.6	Step 6: Repetition of steps 4 and 5	37
5.5.3.6	Conducted Measurements for Radio Determination Devices	37
5.5.3.6.1	Step 1: Start with the RBS Setup.....	37
5.5.3.6.2	Step 2: Adding Interfering Signal Source.....	37
5.5.3.6.3	Step 3: Degradation of Sensitivity Requirement	38
5.5.3.6.4	Step 4: Test of Wanted Technical Performance Criteria	38
5.5.3.6.5	Step 5: Measurement Assessment	38
5.5.3.6.6	Step 6: Repetition of steps 4 and 5	38
Annex A (normative):	Choose interferer for RBR.....	39
A.1	Introduction	39
A.2	Limits for the Interfering Signals	40
A.2.1	Interferer within OFR	40
A.2.1.0	Introduction.....	40
A.2.1.1	Option 1	40
A.2.1.2	Option 2	40

A.2.2	Interferer outside OFR.....	41
A.3	Guidance to Setup the Power Level of the Interfering Signals @ EUT for RBR tests	41
A.3.1	Radiated tests.....	41
A.3.2	Conducted tests	43
Annex B (informative): Guidance on Scaling Receiver Sensitivity.....		44
B.1	General	44
B.2	Scaling of power at the EUT	44
B.3	Scaling distance.....	44
Annex C (informative): Justification of receiver requirements from ETSI EG 203 336		46
C.1	General	46
C.2	Justification	46
C.3	Summary for the RBR requirement.....	48
C.4	Justification RBS-requirement for radio determination devices	49
Annex D (informative): Object and Radar Cross Section		51
D.1	Wanted objects	51
D.2	Direct Object Reflectors.....	51
D.3	Delay Line Object Reflectors	51
D.4	Electronic Object Reflectors	52
D.5	Test Setup with Conventional RCS within Chamber	52
D.6	Test Setup with Radar Object Generator.....	53
Annex E (normative): Assessment procedure to find direction of the highest sensitivity		54
E.1	General	54
E.2	Assessment for communication devices.....	54
E.3	Assessment for radiodetermination devices	55
Annex F (informative): Parameter and Specification in related Standards		56
Annex G (informative): Change history		58
History		59

Intellectual Property Rights

Essential patents

IPRs essential or potentially essential to normative deliverables may have been declared to ETSI. The declarations pertaining to these essential IPRs, if any, are publicly available for **ETSI members and non-members**, and can be found in ETSI SR 000 314: "*Intellectual Property Rights (IPRs); Essential, or potentially Essential, IPRs notified to ETSI in respect of ETSI standards*", which is available from the ETSI Secretariat. Latest updates are available on the ETSI Web server (<https://ipr.etsi.org/>).

Pursuant to the ETSI Directives including the ETSI IPR Policy, no investigation regarding the essentiality of IPRs, including IPR searches, has been carried out by ETSI. No guarantee can be given as to the existence of other IPRs not referenced in ETSI SR 000 314 (or the updates on the ETSI Web server) which are, or may be, or may become, essential to the present document.

Trademarks

The present document may include trademarks and/or tradenames which are asserted and/or registered by their owners. ETSI claims no ownership of these except for any which are indicated as being the property of ETSI, and conveys no right to use or reproduce any trademark and/or tradename. Mention of those trademarks in the present document does not constitute an endorsement by ETSI of products, services or organizations associated with those trademarks.

DECT™, **PLUGTESTS™**, **UMTS™** and the ETSI logo are trademarks of ETSI registered for the benefit of its Members. **3GPP™** and **LTE™** are trademarks of ETSI registered for the benefit of its Members and of the 3GPP Organizational Partners. **oneM2M™** logo is a trademark of ETSI registered for the benefit of its Members and of the oneM2M Partners. **GSM®** and the GSM logo are trademarks registered and owned by the GSM Association.

Foreword

This draft European Standard (EN) has been produced by ETSI Technical Committee Electromagnetic compatibility and Radio spectrum Matters (ERM), and is now submitted for the combined Public Enquiry and Vote phase of the ETSI EN Approval Procedure.

The present document is part 2 of a multi-part deliverable covering Short Range Devices (SRD) and Ultra Wide Band (UWB), as identified below:

Part 1: "Measurement techniques for transmitter requirements";

Part 2: "Measurement techniques for receiver requirements".

Proposed national transposition dates	
Date of latest announcement of this EN (doa):	3 months after ETSI publication
Date of latest publication of new National Standard or endorsement of this EN (dop/e):	6 months after doa
Date of withdrawal of any conflicting National Standard (dow):	6 months after doa

Modal verbs terminology

In the present document "**shall**", "**shall not**", "**should**", "**should not**", "**may**", "**need not**", "**will**", "**will not**", "**can**" and "**cannot**" are to be interpreted as described in clause 3.2 of the [ETSI Drafting Rules](#) (Verbal forms for the expression of provisions).

"**must**" and "**must not**" are **NOT** allowed in ETSI deliverables except when used in direct citation.

Introduction

The present document provides measurement procedures for receiver requirements to address the spectrum efficiency requirements set out in article 3.2 of the RED [i.7].

The basis for this RX concept was developed by ETSI during two Special Task Forces.

First Special Task Force: ETSI STF 494; Update of the UWB related Harmonised Standards covering the essential requirements set out in article 3.2 of the RED [i.7].

The STF 494:

- Started: 2015-05-25
- Ended: 2016-03-31

Outcome:

- ETSI TS 103 361 [i.4]

The second Special Task Force: ETSI STF 541; Signal interferer handling, a new RX requirement to cover the essential requirements set out in article 3.2 of the RED [i.7], was a continuation to implement and consider comments received after the publication of the ETSI TS 103 361 [i.4].

The STF 541:

- Started: 2017-10-06
- Ended: 2019-05-31

Outcome:

- ETSI TR 103 566 [i.2]
- ETSI TS 103 567 [i.3]

There is no specification of receiver parameter values within the present document. These values will be derived from technical specification defined by the responsible ETSI Technical Committees and/or the findings of regulatory studies conducted by the relevant bodies like CEPT/ECC WG SE. The limits/values for the baseline RX-conformance requirements will be specified in the related standard.

In addition to two receiver baseline requirements, it can be necessary that the RX spurious emission requirement could be a further RX requirement in the related standard. This could be necessary if the EUT has a receive only mode or if it is not co-located to the transmitter. The present document specifies the receiver spurious emission requirement and the corresponding test and measurement procedure in clause 5.2.

The present document provides practical information and guidance for the compliance receiver tests of UWB and Short Range technology and related devices.

It is recommended that, in drafting the related standards, a thorough analysis is conducted on all possible applicable receiver parameters (see annex C), selecting the most appropriate RX-requirements and having a robust reasoning for those that are disregarded.

1 Scope

The present document provides measurement procedures for receiver requirements to address the spectrum efficiency requirements set out in article 3.2 of the RED [i.7].

The baseline receiver concept is a set of two parameters given in clause 5 of the present document providing guidance for HS development, which can be further refined by the responsible TB.

Baseline receiver concept comprises the following parameters:

- Receiver Baseline Sensitivity (RBS); and
- Receiver Baseline Resilience (RBR).

The Baseline receiver concept is a further development of the signal interferer handling concept, see ETSI TS 103 361 [i.4].

2 References

2.1 Normative references

References are either specific (identified by date of publication and/or edition number or version number) or non-specific. For specific references, only the cited version applies. For non-specific references, the latest version of the referenced document (including any amendments) applies.

Referenced documents which are not found to be publicly available in the expected location might be found at <https://docbox.etsi.org/Reference/>.

NOTE: While any hyperlinks included in this clause were valid at the time of publication, ETSI cannot guarantee their long term validity.

The following referenced documents are necessary for the application of the present document.

- [1] [ETSI EN 303 883-1 \(V2.1.0\)](#): "Short Range Devices (SRD) and Ultra Wide Band (UWB); Part 1: Measurement techniques for transmitter requirements".

2.2 Informative references

References are either specific (identified by date of publication and/or edition number or version number) or non-specific. For specific references, only the cited version applies. For non-specific references, the latest version of the referenced document (including any amendments) applies.

NOTE: While any hyperlinks included in this clause were valid at the time of publication, ETSI cannot guarantee their long term validity.

The following referenced documents are not necessary for the application of the present document but they assist the user with regard to a particular subject area.

- [i.1] ETSI EG 203 336 (V1.2.1) (05-2020): "Guide for the selection of technical parameters for the production of Harmonised Standards covering article 3.1(b) and article 3.2 of Directive 2014/53/EU".
- [i.2] ETSI TR 103 566 (V1.1.1) (10-2018): "Evaluation status on receiver requirement on Signal interferer handling".
- [i.3] ETSI TS 103 567 (V1.1.1) (09-2019): "Requirements on signal interferer handling".
- [i.4] ETSI TS 103 361 (V1.1.1) (03-2016): "Short Range Devices (SRD) using Ultra Wide Band technology (UWB); Receiver technical requirements, parameters and measurement procedures to fulfil the requirements of the Directive 2014/53/EU".

- [i.5] [ERC Recommendation 74-01](#): "Unwanted emissions in the spurious domain", approved 1998, corrected May 2022.
- [i.6] ETSI TR 103 181-2 (V1.1.1) (06-2014): "Electromagnetic compatibility and Radio spectrum Matters (ERM); Short Range Devices (SRD) using Ultra Wide Band (UWB); Transmission characteristics Part 2: UWB mitigation techniques".
- [i.7] [Directive 2014/53/EU](#) of the European Parliament and of the Council of 16 April 2014 on the harmonisation of the laws of the Member States relating to the making available on the market of radio equipment and repealing Directive 1999/5/EC (RED).
- [i.8] European Communications Office: "[EFIS: ECO Frequency Information System](#)".
- [i.9] ETSI TR 103 181-1 (V1.1.1) (07-2015): "Short Range Devices (SRD) using Ultra Wide Band (UWB); Technical Report Part 1: UWB signal characteristics and overview CEPT/ECC and EC regulation".
- [i.10] ETSI TS 103 788 (V1.1.1) (09-2022): "Short Range Devices (SRD) and Ultra Wide Band (UWB); Measurement techniques and specification for RX conformance tests with target simulator".
- [i.11] ETSI TS 103 789 (V1.1.1) (05-2023): "Short Range Devices (SRD) and Ultra Wide Band (UWB); Radar related parameters and physical test setup for object detection, identification and RCS measurement".
- [i.12] ETSI TS 103 941 (V.0.1.1): "Ultra Wide Band (ERM); Radiated tests for UWB technology-based devices under extreme environmental conditions".

3 Definition of terms, symbols and abbreviations

3.1 Terms

For the purposes of the present document, the terms given in ETSI EN 303 883-1 [1] and the following apply:

event failure rate: ratio of failed tests compared to total number of tests

received power at the EUT ($P_{@EUT}$): received signal with a specified power level the EUT is able to detect

NOTE 1: $P_{@EUT}$ is similar to the specified sensitivity level for the EUT as specified in the related standard (kind of power (e.g. dBm or dBm/MHz) and limit, see note 2.

NOTE 2: $Sensitivity @ EUT = P_{@EUT}$.

Receiver Baseline Resilience (RBR): capability to maintain a pre-determined minimum acceptable level of performance in the presence of unwanted signals over the frequency band of operation, applicable adjacent and remote frequency bands

Receiver Baseline Sensitivity (RBS): capability to receive a wanted signal at application related defined input signal levels while providing a pre-determined minimum acceptable level of technical performance

NOTE 1: The pre-determined minimum acceptable level of technical performance is the basis for all other receiver parameters.

NOTE 2: The purpose of the sensitivity requirement is to assure a basic measure of efficient use of spectrum that strikes balance between sensitivity and the need to avoid being sensitive to interference.

Wanted Technical Performance Criteria (WTPC): specified technical behaviour of the EUT (e.g. information via use-interface) or specified measurable specified output signal to demonstrate that the EUT operates as intended

NOTE: The wanted technical performance will be specified in the rates standard and the requirement is closely linked with the use-case of the EUT.

3.2 Symbols

For the purposes of the present document, the following symbols apply:

σ	Radar Cross Section
ΔD	degradation of the distance from RBR test
Δf	additional frequency range to increase the range (ORF_{RBR}) for the RBR interferer assessment
A	size of the antenna aperture
A_{eff}	effective area of the antenna [m ²]
att	attenuation of the "Variable Attenuator" in [dB]
c	the velocity of light [m/s]
ca	cable attenuation
cf	coupling factor of the coupler in [dB]
d_g	degradation of the sensitivity in [dB]
dB	decibel
dB _i	gain in decibels relative to an isotropic antenna
dB _m	gain in decibels relative to one milliwatt
dl	attenuation of the "Delay Line" in [dB]
D	measurement distance
D_{int}	distance between interfering antenna and EUT
D_{min}	minimum distance from EUT to a specified object the EUT is able to detect
D_{real}	real distance between EUT and target simulator in [m]
D_{sens}	minimum range from an ideal/companion source to the EUT (RX) value in [m]
D_{scal}	scaled distance for the RBS tests
D_{sim}	simulated target distance within target simulator in [m]
f	test frequency in [GHz]
f_c	centre frequency of the EUT OFR
F_{LOWER}	lowest frequency of receiver spurious emission test
F_{UPPER}	highest frequency of receiver spurious emission test
$g_{measure}$	measurement antenna gain in [dBi] at test frequency f
g_i	measurement test antenna gain in [dBi] at test frequency f
g_e	EUT antenna gain in [dBi]
g_{rt}	measurement receiving test antenna gain in [dBi] at test frequency f
G_{int}	interfering transmit antenna
g_{int}	antenna gain of test antenna to transmit interfering signal [dBi]
G_{RX}	gain of the receiving antenna
G_{TX}	gain of the transmitting antenna
il	insertion loss of the coupler in [dB]
$IP_{@EUT}$	interfering Power@EUT
IP_{out}	output power of the interference signal source (generator)
ORF_{RBR}	Frequency range for the RBR interferer assessment
$P_{@EUT}$	Sensitivity @ EUT
P_{EUT}	measured transmitted power of the EUT [e.g. dBm/MHz] or in [W]
P_{meas}	measured received power with the spectrum analyser
P_{out}	output power of the signal generator A
P_{reg}	maximum regulated radiated emission for ideal TX/companion device
P_{RX}	power received back from the object by the EUT [W]
P_{trans}	measured transmitted power from the EUT in [dB]
P_{TX}	transmitter power [W]
$RBR_{in-band}$	frequency range for the RBR interferer assessment ($ORF_{RBR} + 2\Delta f$)
RX_{ref}	sensitivity limit at antenna port
$RX_{refsense}$	scaled sensitivity limit for the RBS test
SCP	Scaling factor (absolute value)
X_{VALUE}	symbol for a value/limit specified in the related standard

3.3 Abbreviations

For the purposes of the present document, the following abbreviations apply:

ACS	Adjacent Channel Selectivity
ADM	Accuracy in Distance Measurement
BER	Bit Error Rate
CATR	Compliant And TRansportable far-field
CEPT	European Conference of Postal and Telecommunications administrations
CW	Continuous Wave
DAA	Detect And Avoid
ECC	Electronic Communications Committee
ECO	European Communications Office
EFIS	ECO Frequency Information System
EFR	Event Failure Ratio
EN	European Norm
ENAP	EN Approval Process
ERM	Electromagnetic compatibility and Radio spectrum Matters
EUT	Equipment Under Test
EUT-RX	Receiver of the Equipment Under Test
FCC	Federal Communications Commission
FMCW	Frequency Modulated Continuous Wave
HH	Horizontal - Horizontal
LAES	Location tracking Applications for Emergency Services
LBT	Listen Before Talk
LT1	Location Tracking type 1
LT2	Location Tracking type 2
MIMO	Multiple Input Multiple Output
NA	Not Applicable
ODP	Object Detection Probability
OFR	Operating Frequency Range
OOB	Out Of Band
OTA	Over The Air
PER	Packet Error Rate
RBR	Receiver Baseline Resilience
RBS	Receiver Baseline Sensitivity
RBW	Resolution BandWidth
RC	Remote Consensus
RCS	Radar Cross Section
RED	Radio Equipment Directive
RF	Radio Frequency
RMS	Root Mean of Squares
RP	Radiated Power
RX	Receiver
SE	Spectrum Engineering
SRD	Short Range Device
STF	Special Task Force of ETSI
TB	Technical Body
TG	Technical Group
TPC	Total Power Control
TX	Transmitter
UWB	Ultra Wide Band
VBW	Video BandWidth
VV	Vertical - Vertical
WG	Working Group
WTPC	Wanted Technical Performance Criteria

4 General

The present document provides practical information and guidance for the compliance receiver tests of UWB and Short Range technology and devices.

The baseline receiver requirements were developed based on the findings of ETSI TR 103 566 [i.2] and ETSI TS 103 567 [i.3], where the signal interferer handling concept from ETSI TS 103 361 [i.4] has been analysed on its applicability for the RED [i.7].

The baseline receiver concept is a set of two parameters given in clause 5 of the present document providing guidance for harmonised standard development, which can be further refined by the responsible TB.

Baseline receiver concept comprises the following parameters:

- Receiver Baseline Sensitivity (RBS); see clause 5.4; and
- Receiver Baseline Resilience (RBR); see clause 5.5.

The baseline receiver concept is a further development of the signal interferer handling concept, see ETSI TS 103 361 [i.4].

In annex C these two parameters are put in relation to existing receiver parameters given in ETSI EG 203 336 [i.1] and the assessments prepared by ETSI STF 494 and 541. Annex C additionally provides the summary assessment/justification for this new baseline receiver concept described in the present document.

5 Receiver Requirements

5.1 General Guidance on RX measurement

Complementary information to the conformance tests in the clauses below are provided in annex A and B of ETSI EN 303 883-1 [1], for example:

- test conditions, power supply and ambient temperatures (see clause A.5 of ETSI EN 303 883-1 [1]);
- measurement uncertainty and the interpretation of the measurement results (see clause A.8 of ETSI EN 303 883-1 [1]);
- test setups and radiated measurements (see annex B of ETSI EN 303 883-1 [1]).

5.2 Receiver Spurious Emissions

5.2.1 Description

The RX spurious emissions shall be measured within the frequency range defined in table 2.

The receiver spurious emission requirement is applicable for communication and tracking EUT if the EUT is a receive only device (TX not implemented) or for EUT which has a receive only mode (TX off, standby, idle).

For radiodetermination and sensor applications (e.g. radar sensor) the receiver spurious emission requirement is applicable for EUT if it is a receive only device (receiver is separated from the transmitter within a separate housing) or for EUT which has a receive only mode (TX off, standby, idle). The receive only mode shall be specified in the related standard based on the intended-use and the EUT device categories. For EUT without a receive only mode than the spurious emissions are covered by provisions of clause 5.5 of ETSI EN 303 883-1 [1] on TX unwanted emissions.

5.2.2 Limits

The limit for RX spurious emissions could be provided in the applicable related standard.

If no limits for RX spurious emissions are provided in the related standard, then the limits in table 1 shall apply.

Table 1: Receiver spurious emission limits in line with ERC REC 74-01 [i.5]

Frequency range	Limit values
F_{LOWER} to 1 000 MHz (see note)	-57 dBm
$1 \text{ GHz} < f \leq F_{\text{UPPER}}$ (see note)	-47 dBm
NOTE: F_{UPPER} and F_{LOWER} are linked with the OFR of the EUT, see table 2.	

Table 2: Frequency range for the RX spurious emission test, linked with EUT OFR in line with ERC REC 74-01 [i.5]

Fundamental frequency range defined by f_L and f_H (see note 2)	Frequency range for measurements	
	Lower frequency (F_{LOWER}) (see note 3)	Upper frequency (F_{UPPER})
300 to 600 MHz	30 MHz	3 GHz
600 MHz to 5,2 GHz	30 MHz	5 th harmonic (see note 1)
5,2 to 13 GHz	30 MHz	26 GHz
13 to 150 GHz	30 MHz	2 nd harmonic (see note 1)
150 to 300 GHz	30 MHz	300 GHz
NOTE 1: F_{UPPER} is the stated harmonic of f_H (the upper edge of the OFR, which is measured in ETSI EN 303 883-1 [1], clause 5.2).		
NOTE 2: F_{LOWER} has to be selected based on f_L and F_{UPPER} based on f_H (f_L and f_H can be measured according to ETSI EN 303 883-1 [1], clause 5.2); for receive only devices f_H and f_L of the related EUT/companion device shall be used.		
NOTE 3: For EUT operating below 300 MHz the spurious emissions limits below 30 MHz shall be specified in the related standard.		

5.2.3 Conformance

5.2.3.1 General

The following conformance test shall be used for RX unwanted emissions (OOB and spurious emissions) if not otherwise specified in the related standard.

In case of integral antenna equipment with no antenna connector the measurement shall be radiated, otherwise equipment with antenna connectors, the measurement shall be at the antenna port (conducted). Therefore, the related standard need to specify the test setup (see for guidance ETSI EN 303 883-1 [1], clause B.1 for radiated or annex B.3 for conducted). The conformance test for TX unwanted emission need to be used to measure/asses the emission in each direction around the EUT as specified in the related standard (see for guidance ETSI EN 303 883-1 [1], clause B.1 and clause B.4 for radiated or clause B.3 for conducted).

The conformance test shall be performed in two steps:

- step 1: pre-scan with peak detector (see clause 5.2.3.2);
- step 2: if necessary, measurement with peak detector and calculate the RMS over 1 s, if not otherwise specified in the related standard (see clause 5.2.3.3).

NOTE: The split in two steps is done because: a complete scan with RMS could take a long time. The measurement with peak detector is an "overestimation" of the emission and is only to find the frequencies with the highest emissions that will be verified in step 2.

5.2.3.2 Step 1: Measurement with Peak Detector

The following spectrum analyser settings shall be used:

- Start frequency: F_{LOWER}
- Stop frequency: F_{UPPER}

NOTE 1: There could be a need to split the measurement into different frequency ranges depending on the measurement set-up (e.g. external mixers, bandwidth of antennas and waveguides, RBW).

- Resolution BandWidth (RBW):
 - ≥ 100 kHz between 30 MHz and 1 GHz
 - ≥ 1 MHz above 1 GHz
- Video BandWidth (VBW): \geq RBW
- Detector mode: peak
- Trace mode: max hold
- Sweep time: wait until the reading in the display is stable

Number of measurement points: At least equal to frequency span divided by RBW.

NOTE 2: The peak detector is sensitive to corruption by events occurring only once or for a very small amount of time and/or caused by different devices than the EUT.

NOTE 3: If the signal repetition of the EUT is known the measurement time per measurement point is equal or larger of the signal repetition time.

Assessment of step 1: Compare the measurement results with the limit (see related standard and table 1) and record the frequencies and direction of the emission (for radiated measurement) where the limit is exceeded. For these frequencies go to step 2 (clause 5.2.3.3).

5.2.3.3 Step 2: Measurement with Peak Detector and calculation RMS Value

- Set the spectrum analyser to zero span mode
- Resolution BandWidth (RBW):
 - 100 kHz between 30 MHz and 1 GHz
 - 1 MHz above 1 GHz
- Video BandWidth (VBW): \geq RBW
- Detector mode: peak
- Trace mode: clear write
- Sweep time: 1 s; if not otherwise specified in the related standard:
 - a) Set the spectrum analyser to the first recorded frequency (and direction) from step 1 (clause 5.2.3.2).
 - b) Measure and record the spurious emission value over the sweep time.
 - c) Calculate the RMS value over the sweep time, using the post processing capability function of the spectrum analyser.
 - d) Record the calculated RMS value and compare it against the limit (see related standard and table 1).
 - e) Repeat b) - d) for all frequencies from step 1.

5.3 Use-Case Specific Input Parameters for Receiver Baseline Requirements

5.3.1 Introduction

A meaningful test of receiver requirements is only possible with knowledge of the intended use (use cases) of the EUT. Therefore, the related standard (which is mostly use case specific) needs to provide all required use case specific input parameters for the receiver tests, such as:

- Wanted technical performance criteria to quantify the EUT output (e.g. BER in [%], PER in [%], false alarm rate, detection probability in [%], distance degradation).
- Sensitivity or distance limit for a radio communication application and/or a radiodetermination application.
- The RCS and the movement/velocity of the reference target for a radiodetermination application.

More information on possible parameters to be made available in related standards are offered in clauses 5.3.2 and 5.3.3.

5.3.2 Wanted Technical Performance Criteria

For radio communication applications the following wanted technical performance criteria might be possible:

- after demodulation, a raw data signal with a Bit Error Ratio (BER) of 10^{-3} without correction; or
- after demodulation, a message acceptance ratio of 80 %; or
- Packet Error Ratio (PER) [X] in %.

NOTE 1: For communication devices.

- Event Failure Ratio (EFR) [X] in %.

NOTE 2: For location tracking devices.

- For radiodetermination applications the following technical wanted performance criteria might be possible:
 - a false alarm rate of X %; or
 - a detection probability of X %;
 - measurement accuracy in $\pm X$ of the distance, speed, material parameter.

The lists of wanted technical performance criteria above are non-exhaustive lists, other requirements can be specified in the related standard.

5.3.3 Examples of Use-Case Specific Input Parameter for Receiver Tests

5.3.3.1 Communication/Location Tracking Device

Examples of use case specific input parameters for receiver tests for all kind of communication are provided in table 3 below. Such systems could be for example:

- Generic communication devices.
- Location tracking applications including Location Tracking type 1 (LT1), Location Tracking type 2 (LT2), and Location tracking Applications for Emergency Services (LAES), see ETSI TR 103 181-1 [i.9].
- Active/comfort keyless entry systems.

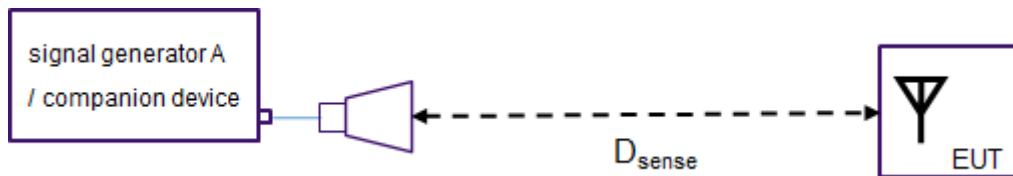

Figure 1: Generic communication (test) scenario

Table 3: Examples of wanted technical performance criteria for communication and location tracking applications

Use-case related requirements		
D_{sense}	Minimum range D_{sense} from an ideal/companion source to the EUT (RX) value in [m]	
P_{reg}	Maximum regulated radiated emission for ideal TX/companion device See note 1	
Signal information	Data rate, Bandwidth See note 1	
Possible wanted technical performance criterion		
Packet Error Ratio (PER)	XVALUE, see note 2	
Event Failure Ratio (EFR)	XVALUE, see note 3	Alternative
Sensitivity Limit at antenna port (RX_{ref})	XVALUE in [dBm or dBm/MHz]	Alternative
NOTE 1: See TX-requirement in related standard.		
NOTE 2: For communication devices.		
NOTE 3: For location tracking devices.		

Each related standard should provide such table for each operational mode defined in the related standard.

NOTE: Only the relevant requirement for the use-case needs to be provided in the related standard.

5.3.3.2 Radio Determination Device (non-contact based)

Examples of use case specific input parameters for receiver tests for all kind of radar such as determination devices, which are able to detect objects via air (non-contact base), are provided in table 4. Such systems could be for example:

- (Tank) level probing radar.
- Surveillance radars.
- Intrusion detection sensors.
- Through-free space non-contact vital signs sensor.

The technical wanted performance criteria of such EUT (see table 4) is the verification if the EUT is able to detect a specified object at a specified distance. This could be a static scenario (object quasi fixed relative to the EUT, see figure 2) or with a moving object (relative movements to the EUT, see figure 3).

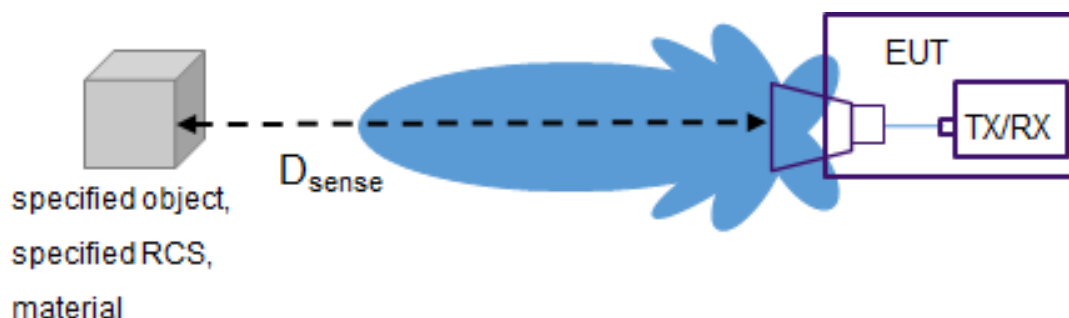

Figure 2: Generic static scenario

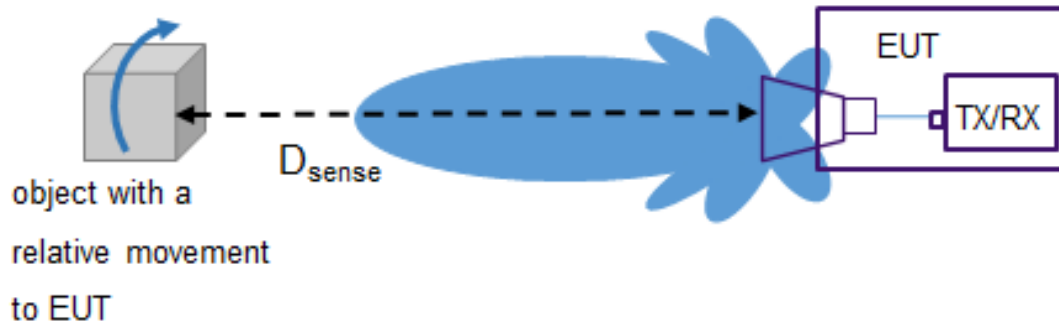

Figure 3: Generic scenario with movements

Table 4: Examples of wanted technical performance criteria for radio determination applications

Possible requirements related to the use-case/intended use (scope of the EN) for each RX-test		
Requirement	Remark	Limit
Possible wanted technical performance criteria		
Detection probability	Minimum value which each EUT shall fulfill (e.g. the detection probability limit is 90 % and the measured detection probability shall be ≥ 90 %)	X _{VALUE} in [%] over number of measurements of the EUT
False alarm rate	Maximum value which each EUT shall fulfill (e.g. false alarm rate limit is 10 % and the measured false alarm rate shall be ≤ 10 %)	X _{VALUE} in [%] over number of measurements of the EUT
Specification of distance and object for detection		
Distance/Sensitivity	Value of distance the EUT shall be able to detect the object (e.g. the EUT shall be able to detect a RCS of = 10 dBsm in a distance of = 10 m)	X _{VALUE} in [m]
RCS	Smallest object the EUT shall be able to detect	X _{VALUE} in [m ²]
RCS deviation		\pm X _{VALUE} in [m ²]
Distance deviation		\pm X _{VALUE} in [m] or \pm X _{VALUE} in [%] per distance
Object speed	If there is a speed dependent requirement, moving object information	X _{VALUE} in [m/s]
Object separation	Minimum distance between two object the EUT shall be able to differentiate	X _{VALUE} in [m]

Table 5: Example of wanted technical performance criteria for some specific radio determination application

Use-case related requirements	
D_{sense}	Can be specified either: <ul style="list-style-type: none"> • as distance (D_{sense}) between EUT and specified object (see below) in [m]; or • the field strength X_{VALUE} in [V/m] of the receiving signal at the EUT.
Object	To specify the smallest object the EUT shall be able to detect (RCS, object speed, object separation). EXAMPLE: The EUT shall be able to detect a RCS of = 2 m ² in a distance of $D_{\text{sens}} = 10$ m while fulfilling the wanted technical performance criteria (see below).
P_{reg}	Maximum regulated emission for ideal EUT. See note 1.
Scenario	Objects, Speed, object separation. See note 2.
Possible wanted technical performance criterion (see note 5)	
Object Detection Probability (ODP)	X_{VALUE} in [%]. See note 3. EXAMPLE: The detection probability limit is 90 % and the measured detection probability shall be ≥ 90 %).
False alarm rate	X_{VALUE} in [%]. See note 4. EXAMPLE: False alarm rate limit is 10 % and the measured false alarm rate shall be ≤ 10 %.
Accuracy in Distance Measurement (ADM)	$\ln \pm X_{\text{VALUE}}$ in [%] of the distance between EUT and object.
NOTE 1: See TX-requirement in the related EN. NOTE 2: Detailed scenario set-up shall be provided in related EN. NOTE 3: During number of measurements of the EUT. NOTE 4: During number of measurements of the EUT (alternative to ODP). NOTE 5: The related standard needs to specify at least one performance criteria for the specified intended use.	

Each related standard should provide such table for each operational mode defined in the standard.

NOTE: More information on object specification and RCS are provided in annex D.

5.3.3.3 Material contact-based radio determination device

These technical wanted performance requirement criteria cover all kind of determination devices which are in contact with the material under investigation (e.g. humidity measurement of a wall) or which are developed to detect an object inside another material (e.g. stud finder) or a combination of both (e.g. building material analysis).

In other words, the wanted technical performance criteria of such EUT is the verification if the EUT is able to detect an object inside another material or to determine specific characteristics of a material.

NOTE 1: For such devices there may be a need to have a relative "movement" between the EUT and the material/object under investigation. This could be realized by:

- EUT moved over the material under investigation, see figure 4.
- The antenna characteristics of the EUT can be changed (e.g. scanning antenna pattern), see figure 4.
- The object under investigation has its own movement (e.g. heartbeat detection), see figure 5.

This "relative" movement is part of the intend use/technical performance criteria and shall be specified in the related harmonised standard.

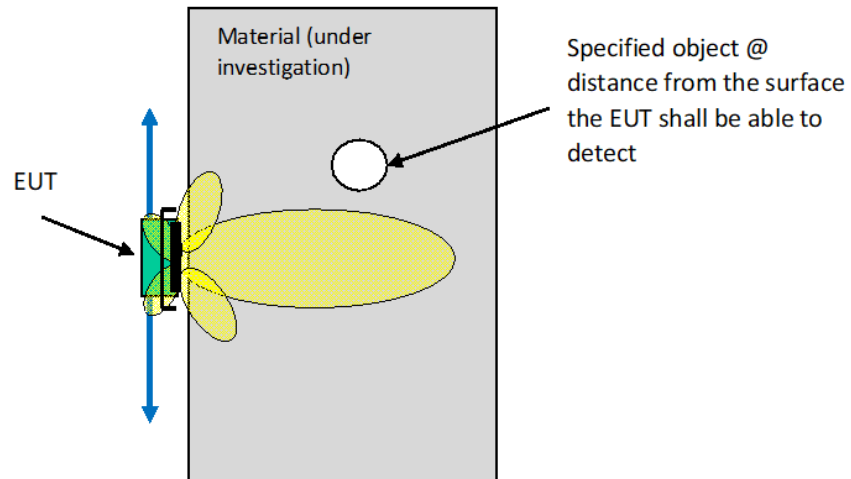

Figure 4: Scenario in which the EUT has a relative movement to the material under investigation

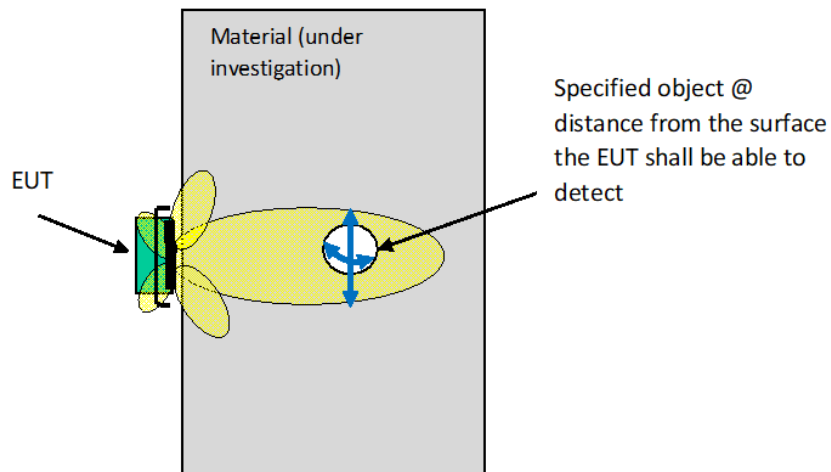

Figure 5: Scenario in which the object has a relative movement to the EUT

Examples of use case specific input parameters for receiver tests for these radio determination devices are provided in table 6.

NOTE 2: There are also use-case possible which are a combination of clauses 5.3.3.2 and 5.3.3.3. This could be the case if the material investigation will be realized via air, e.g. vital sign monitoring.

Table 6: Examples of wanted technical performance criterion for material investigation applications

Use-case related requirements	
D_{sense}	Specified distance D_{sense} between EUT and object (inside the material under investigation, see below).
Material parameters	Material characteristic information. See note 1.
Object	To specify the smallest object the EUT shall be able to detect (RCS, object size, object material, object speed, object separation). EXAMPLE: The EUT shall be able to detect a defined object in a distance of D_{sense} while fulfilling the technical wanted performance criteria (see below).
	Maximum regulated emission for ideal EUT. See note 2.
Scenario	Description of test scenario. See note 3.
Possible wanted technical performance criteria	
Object Detection Probability (ODP)	[X] in %. EXAMPLE: The detection probability limit is 90 % and the measured detection probability shall be ≥ 90 %.
Accuracy in Distance Measurement (ADM)	In \pm % of the distance between EUT and object.
Object detection	Yes/No.
NOTE 1: More information about RCS, see annex D. NOTE 2: See TX-requirement in the related EN. NOTE 3: Detailed scenario set-up shall be provided in related EN (included if a trained operator is necessary for the test to "realize" the relative movement between EUT and object).	

Each related standard should provide such a table for each operational mode defined in the standard.

NOTE 3: Only the relevant requirement for the use-case needs to be provided in the standard.

5.4 Receiver Baseline Sensitivity (RBS)

5.4.1 Description

Receiver Baseline Sensitivity is the capability to receive a wanted signal at application related defined input signal levels while providing a pre-determined minimum acceptable level of technical performance.

Two different use cases need to be differentiated due to the different test scenario:

- radio communication applications: EUT (Receiver) and a TX-counterpart; or
- radiodetermination applications: target with defined RCS in a distance to the Transceiver.

5.4.2 Limits

The limit for receiver (baseline) sensitivity needs to be provided in the related standard for the use cases requirements described in clause 5.3.2.

Examples are provided for:

- communication/location tracking devices in clause 5.3.3.1;
- for radio determination device (non-contact based) in clause 5.3.3.2;
- for material contact based radio determination devices in clause 5.3.3.3.

The sensitivity limit could be coupled to the TX power of the EUT or companion device. An example of how to couple the sensitivity limit with the TX power is described in annex B. The related "scaling" parameter SCP needs to be specified in the related standard.

5.4.3 Conformance

5.4.3.1 General

Table 7 summarizes applicable conformance tests and limits for the baseline sensitivity requirement dependent on:

- the application (radio communication or radiodetermination);
- the availability of an antenna connector;
- the availability of an adjustable TX counterpart.

Table 7: Sensitivity measurement procedures and conformance tests

Antenna connector (temporary or permanent)	Radio communication applications			Radiodetermination applications	
	Available	Not available (integral antenna)		Not available (integral antenna)	Available
Transmitter for Rx tests with adjustable Tx power (see note)	NA	Available	Not available	NA	NA
Test scenario	Conducted	Radiated	Radiated	Radiated	Conducted
Conformance tests	Clause 5.4.3.2	Clause 5.4.3.3	Clause 5.4.3.4	Clause 5.4.3.5	Clause 5.4.3.6

NOTE: TX signal of the same EUT or separate signal generator/companion device.

5.4.3.2 Conducted measurements for radio communication devices

5.4.3.2.0 General

A signal generator A (or a companion transmitter) shall produce a test signal according to the modulation of the EUT (see related standard).

5.4.3.2.1 Step 1: Wanted Technical Performance Criteria

Specifications for the technical performance criteria and the related parameters shall be taken from the related standard (see also clause 5.3.3.1 and table 3).

5.4.3.2.2 Step 2: Sensitivity Requirement (Power)

The sensitivity limit shall be derived based on the approach in clause B.1 for the case that the scaling factor approach from annex B is used in the related standard. Otherwise the related standard shall provide the sensitivity limit at the EUT.

5.4.3.2.3 Step 3: Measurement Procedure

The EUT shall be connected through a variable attenuator and a directional coupler to the output of a signal generator A (or a companion transmitter) according to figure 6.

The received power level at the EUT could be measured with a spectrum analyser at the output of the directional coupler according to figure 6.

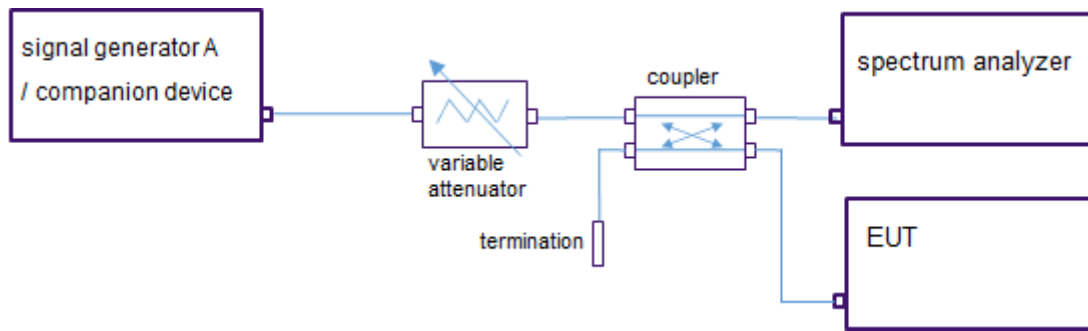

Figure 6: Conducted RBS measurement set-up for communication and location tracking applications

For Signal generator A: The output of signal generator A shall be switched on:

- at the operating frequency of the EUT.

For companion device: It shall be switched on:

- the output shall be set to the same mode and frequency as the EUT-RX.

The power at the EUT can be calculated as follows (see figure 7 and equation (1)) out of the measurement.

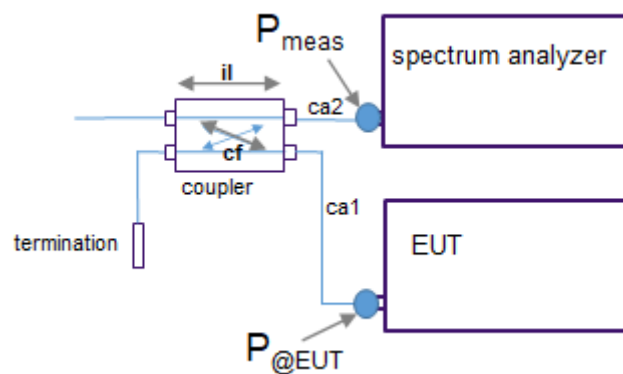

Figure 7: To calculate $P_{@EUT}$

$$P_{@EUT} = P_{meas} - ca1 - cf + il + ca2 \quad (1)$$

with:

- $P_{@EUT}$: received power at the EUT (similar (type and limit) to sensitivity level of the EUT as specified in the related EN).

NOTE 1: Some devices could use dBm limits, other dBm/MHz.

- P_{meas} : measured received power with the spectrum analyser in [see $P_{@EUT}$].
- ca : cable attenuation in [dB].
- cf : coupling factor of the coupler in [dB].
- il : insertion loss of the coupler in [dB].

NOTE 2: The usage of a directional coupler is from the technical point of view not necessary. The power at the EUT could be measured also by replacing the EUT with a spectrum analyser. But the usage of a directional coupler would allow the monitoring of the signal during the test and for the necessary "interferer tests" there would be no change in the signal path necessary to get an option to incorporate the interfering signal source into the test setup.

NOTE 3: Possible RX antenna gain and/or temporary antenna connector influences need to be considered in the assessment of the RBS requirement in the related standard.

The output power and/or the variable attenuator (see figure 6) shall be adjusted according to one of the following options:

- Option 1: Adjust the power at the EUT with the variable attenuator until the received power at the EUT is equal to or less the sensitivity limit specified in the related standard. The technical performance criterion (which shall be provided in the related standard), shall be then measured and recorded.
- Option 2: Adjust the power at the EUT with the variable attenuator until the technical performance criterion is just achieved; then measure the power at the EUT antenna port.

5.4.3.2.4 Step 4: Wanted Technical Performance Criteria Assessment

The test is passed, if the wanted technical performance criteria and the sensitivity limit are met, see related standard.

5.4.3.3 Radiated Measurements for Radio Communication Devices with Power Limit

5.4.3.3.0 General

A signal generator A (or a companion transmitter) shall produce a test signal according to the modulation of the EUT (see related standard).

A test site shall be selected from those described in ETSI EN 303 883-1 [1], clause B.2.2.

5.4.3.3.1 Step 1: Wanted Technical Performance Criteria

Specifications for the wanted technical performance criteria and the related parameters shall be taken from the related standard (see also clause 5.3.3.1 and table 3).

5.4.3.3.2 Step 2: Sensitivity Requirement (Power)

The sensitivity limit shall be derived based on the approach in clause B.2 for the case that the scaling factor approach from annex B is used in the related harmonised standard. Otherwise the related standard shall provide the sensitivity limit at the EUT.

5.4.3.3.3 Step 3: Measurement Procedure

5.4.3.3.3.1 General

For the test set-up the antenna pattern of the EUT needs to be considered.

For EUT with the same antenna used for transmit and receive (same antenna pattern for TX and RX) the EUT shall be pointed with the direction of the max TX emission to the main beam direction of the transmit test antenna, see figure 8.

After the arrangement the measurement procedure as described in clause 5.4.3.3.3.2 shall be used.

For EUT with another RX antenna pattern than for the TX antenna pattern, the direction of the highest sensitivity shall be considered. To assess the most sensitive direction, the assessment procedure as described in annex E shall be used.

5.4.3.3.3.2 Measurement Procedure

The principal set-up is shown in figure 8.

For the signal source two options are possible:

- With a signal generator: The output of a signal generator A shall be connected to a transmit test antenna. A transmit test antenna according to ETSI EN 303 883-1 [1], clause B.2.2.5 shall be placed to the test site pointing with its main beam direction to the EUT and at the same height as the EUT.
- With a companion transmitter: The companion transmitter with integral antenna shall be placed to the test site pointing with its main beam direction to the EUT and at the same height as the EUT.

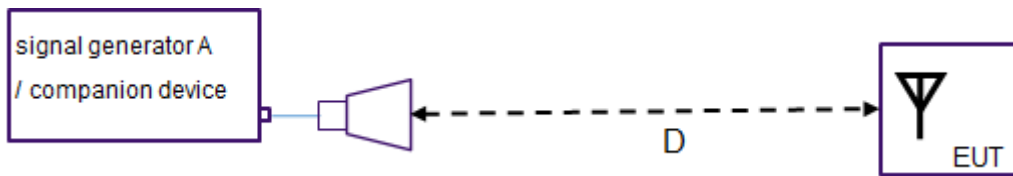

Figure 8: Radiated RBS test set-up for communication and location tracking use-cases

For Signal generator A: The output of signal generator A shall be switched on:

- at the operating frequency of the EUT.

For companion device: It shall be switched on:

- the output shall be set to the correct/similar mode than the EUT-RX.

Two options are possible to adjust the power at the EUT:

- Option 1 (recommended method): Adjust the power at the signal generator A/companion device and/or change the distance D until the received power at the EUT is equal to or less than the Sensitivity Requirement as assessed in step 2, (clause 5.4.3.3.2); record the power of signal generator A/companion device and distance D .
- Option 2: Adjust the power at the signal generator A/companion device and/or change the distance D until the wanted technical performance criterion is just achieved; record the power of signal generator A/companion device and distance D .

The power received at the EUT antenna port cannot directly be measured due to the integral antenna. Therefore, the power received at the EUT antenna port will be derived based on an assumed antenna gain of the EUT of 0 dBi. It can then be calculated with the known radiated power e.i.r.p. of the signal generator A (or of the companion transmitter), the distance D to the EUT and the test frequency f , see figure 9 and equation (2).

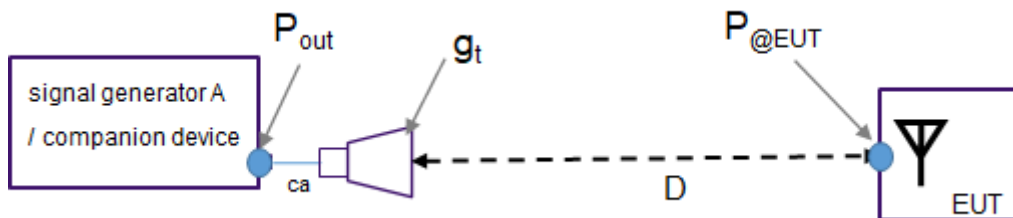

Figure 9: Calculation P_{out} for test the specified radiated sensitivity level of the EUT

$$P_{@EUT} = P_{out} + g_t - 32,5 - 20 \log(D) - 20 \log(f) - ca \quad (2)$$

with:

- P_{out} : output power of the signal generator A (same dimension as sensitivity limit of the EUT).
- g_t : measurement test antenna gain in [dBi] at test frequency f .
- D : distance in [m].
- f : test frequency in [GHz].
- ca : cable attenuation between Signal Generator A and test antenna in [dB].
- $P_{@EUT}$: received power at the EUT (similar (kind and limit) to sensitivity level of the EUT as specified in the related standard).

The power received at the EUT antenna port can alternatively be measured directly by replacing the EUT by a measurement antenna (known antenna gain) with a spectrum analyser, see figure 10 and equation (3).

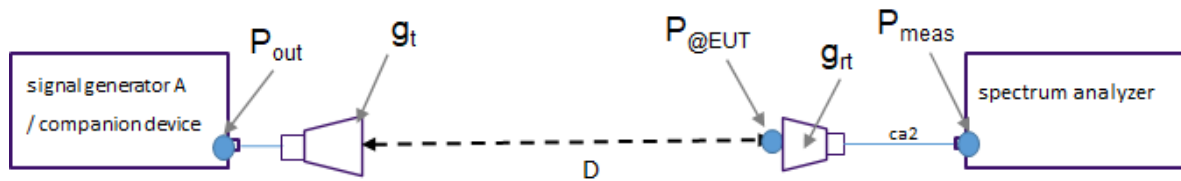

Figure 10: Measurement sensitivity level @ EUT

$$P_{@EUT} = P_{meas} + ca2 - g_{rt} \quad (3)$$

with:

- $P_{@EUT}$: received power at the EUT (similar (kind and limit) to sensitivity level of the EUT as specified in the related EN).
- P_{meas} : measured power at the spectrum analyser in [similar to sensitivity level of the EUT].
- g_{rt} : measurement receiving test antenna gain in [dBi] at test frequency f .
- $ca2$: cable attenuation between receiving test antenna and spectrum analyser in [dB].

5.4.3.3.4 Step 4: Wanted Technical Performance Criteria Assessment

The test is passed, if the technical wanted performance criteria and the sensitivity limit are met, see related standard.

5.4.3.4 Radiated measurements for radio communication devices with distance limit

5.4.3.4.0 General

A signal generator A (or a companion transmitter) shall produce a test signal according to the modulation of the EUT (see related standard).

A test site shall be selected from those described in ETSI EN 303 883-1 [1], clause B.2.2.

5.4.3.4.1 Step 1: Wanted Technical Performance Criteria

Specifications for the technical performance criteria and the related parameters shall be taken from the related standard (see also clause 5.3.3.1 and table 3).

5.4.3.4.2 Step 2: Sensitivity Requirement (Distance)

The sensitivity limit shall be derived based on the approach in clause B.3 for the case that the scaling factor approach from annex B is used in the related standard (D_{scal}) [m]. Otherwise the related harmonised standard shall provide the distance limit (D_{sens}) [m].

5.4.3.4.3 Step 3: Measurement Procedure

5.4.3.3.4.1 General

For the test set-up the antenna pattern of the EUT needs to be considered.

For EUT with the same antenna used for transmit and receive (same antenna pattern for TX and RX) the EUT shall be pointed with the direction of the max TX emission to the main beam direction of the transmit test antenna, see figure 11.

After the arrangement the measurement procedure as described in clause 5.4.3.3.4.2 shall be used.

For EUT with another RX antenna pattern than for the TX antenna pattern, the direction of the highest (sufficient) sensitivity shall be considered. To assess the most sensitive direction, the assessment procedure as described in annex E shall be used.

5.4.3.3.4.2 Measurement Procedure

The principal set-up is shown in figure 11.

For the signal source two options are possible:

- The output of a signal generator A shall be connected to a transmit test antenna. The transmit test antenna according to ETSI EN 303 883-1 [1], clause B.2.2.5 shall be placed on the test site pointing to the EUT and at the same height as the EUT.
- Alternatively, a companion transmitter could be used with the antenna main beam direction pointing to the EUT.

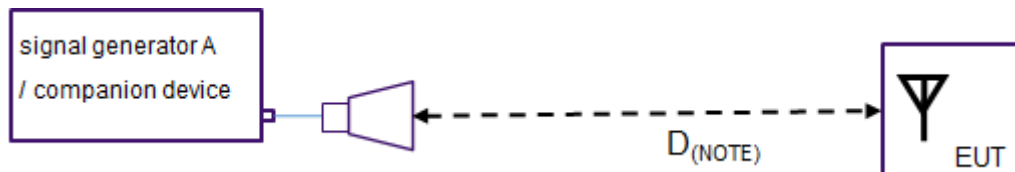

NOTE: Distance (D) see step 2, clause 5.4.3.4.2.

Figure 11: Radiated RBS test set-up for communication & location tracking use-cases; distance limit

The TX power of the signal generator A with test antenna and of the companion device shall be at the same level as the EUT. This shall be verified by the TX measurement specified in the related standard.

For Signal generator A: The output of signal generator A (or companion transmitter) shall be switched on:

- at the operating frequency of the EUT;
- the radiated power of the companion device or of signal generator plus test antenna shall be equal to the radiated power of the EUT (see related standard).

For companion device:

- the output shall be set to the correct/similar mode than the EUT-RX.

Two methods are now possible:

- Option 1 (recommended method): Adjust the distance D to the distance limit assessed in step 2 (clause 5.4.3.4.2); measure and record the technical wanted performance criteria.
- Option 2: Adjust the distance D until the technical wanted performance criteria is just achieved; record distance D. For this option the measured distance shall be larger than the distance limit in step 2 (clause 5.4.3.4.2).

5.4.3.4.4 Step 4: Technical Wanted Performance Criteria Assessment

The test is passed, if the technical wanted performance criteria and the sensitivity limit are met, see related standard.

5.4.3.5 Radiated Measurements for Radiodetermination Applications with Distance Limit

5.4.3.5.0 General

A test site shall be selected from those described in ETSI EN 303 883-1 [1], clause B.2.2.

5.4.3.5.1 Step 1: Technical Performance Criteria

Specifications for the technical performance criteria and the related parameters shall be taken from the applicable standard (see also clauses 5.3.3.2 and 5.3.3.3).

The test scenario shall be set-up as described in the related standard.

5.4.3.5.2 Step 2: Sensitivity Requirement (Distance)

The sensitivity limit shall be derived based on the approach in clause B.3 for the case that the scaling factor approach from annex B is used in the related standard (D_{scal} [m]). Otherwise the related standard shall define the distance of the detection range of the EUT as distance for the sensitivity requirement, D_{sens} [m].

5.4.3.5.3 Step 3: Measurement Procedure

5.4.3.5.3.1 General

For the test set-up the antenna pattern of the EUT needs to be considered.

For EUT with the same antenna used for transmit and receive (same antenna pattern for TX and RX) the EUT shall be pointed with the direction of the max TX emission to the main beam direction of the transmit test antenna, see figure 12.

After the arrangement the measurement procedure as described in clause 5.4.3.5.3.2 shall be used.

For EUT with another RX antenna pattern than for the TX antenna pattern, the direction of the highest (sufficient) sensitivity shall be considered. To assess the most sensitive direction, the assessment procedure as described in annex E shall be used.

5.4.3.5.3.2 Measurement Procedure

The EUT shall be placed with its operational direction pointing to the reference target/object (to be taken from the related standard, see also clauses 5.3.3.2 and 5.3.3.3) in a given distance. The target could also be simulated with a target simulator (see below and annex D).

In figure 12, a generic determination use case "via" free space is shown. Examples of other possible use-cases are described in clauses 5.3.3.2 and 5.3.3.3.

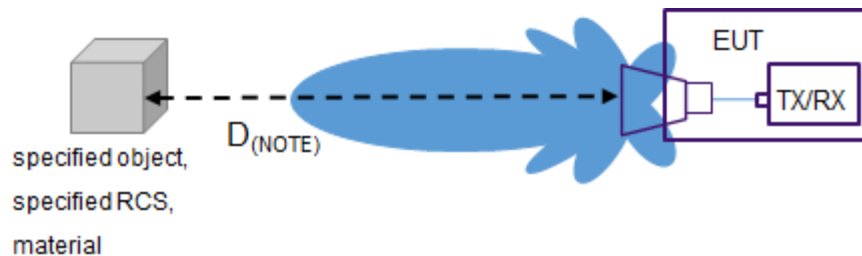

NOTE: Distance (D) see step 2, clause 5.4.3.5.2.

Figure 12: Radiated RBS test set-up for radio determination via free space

For radio determination applications which work on close contact with a "material" the EUT (see clause 5.3.3.3 and figure 13) shall be placed as described in the user manual to the reference material/object. The detailed test procedure shall be described in the related standard.

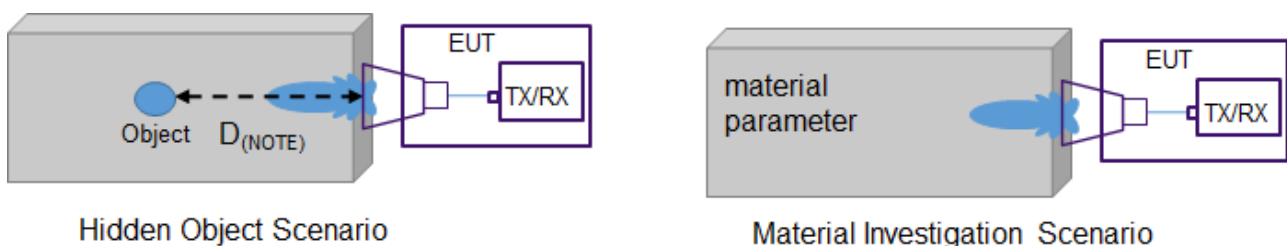

NOTE: Distance (D) see step 2, clause 5.4.3.5.2.

Figure 13: Radiated RBS test set-up for radio determination in contact with material

For the case that the usage of a target simulator (see annex D) is specified within the related standard (e.g. if D_{sense} is too large for realization within test environment), then the distance of D_{sense} can be assessed as shown in figure 14 and equation (4). For more details on target simulator, see ETSI TS 103 788 [i.10].

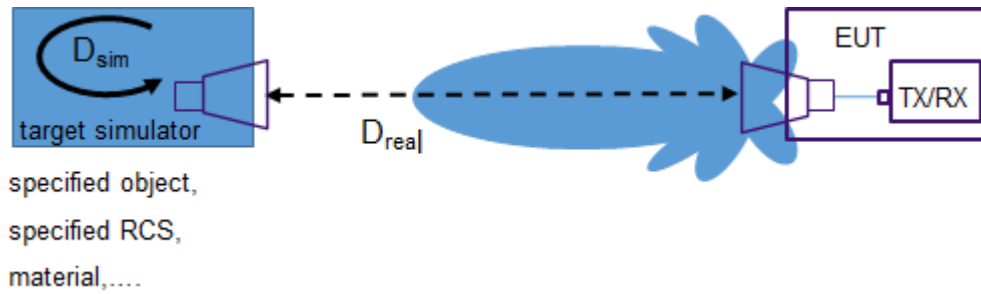

Figure 14: Radiated RBS test set-up for radio determination via free space and target simulator

$$D_{\text{sense}} = D_{\text{real}} + D_{\text{sim}} \quad (4)$$

with:

- D_{sens} : specified distance in the related standard for the RBS test [m], see clause 5.4.3.5.2 and related standard.
- D_{real} : real distance between EUT and target simulator in [m].
- D_{sim} : simulated target distance within target simulator in [m].

The EUT shall be switched on.

Two methods are now possible:

- Option 1 (recommended method): Adjust the distance D to the distance limit assessed in step 2 (clause 5.4.3.5.2); measure and record the technical wanted performance criteria.
- Option 2: Adjust the distance D until the technical wanted performance criteria is just achieved; record distance D . For this option the measured distance shall be larger than the distance limit in step 2 (clause 5.4.3.5.2).

5.4.3.5.4 Step 4: Wanted Technical Performance Criteria Assessment

The test is passed, if the wanted technical performance criteria and the sensitivity limit are met, see related standard.

5.4.3.6 Conducted measurements for radio determination devices

5.4.3.6.0 General

A specific test site is not required as the measurement is conducted.

5.4.3.6.1 Step 1: Wanted Technical Performance Criteria

The information on the technical performance criteria and the related parameters shall be taken from the related harmonised standard (see also clauses 5.3.3.2 and 5.3.3.3).

5.4.3.6.2 Step 2: Sensitivity Requirement (Power)

The sensitivity limit shall be derived based on the approach in clause B.2 for the case that the scaling factor approach from annex B is used in the related harmonised standard. Otherwise the related harmonised standard shall provide the sensitivity limit in dBm at the EUT antenna port.

5.4.3.6.3 Step 3: Measurement Procedure

The EUT shall be connected through a coupler, a variable attenuator and a delay line to a short-circuited cable. The short-circuited cable is to create a defined RX-signal. The minimum length of the cable (specific for the delay line) shall be specified in the related standard. By adapting the variable attenuator, the reflected power can be adjusted and thus also the received power at the EUT antenna port. The coupler is not necessary for RBS assessment but later required for the RBR test (see clause 5.5). A test set-up is shown in figure 15. The spectrum analyser is optional and not mandatory.

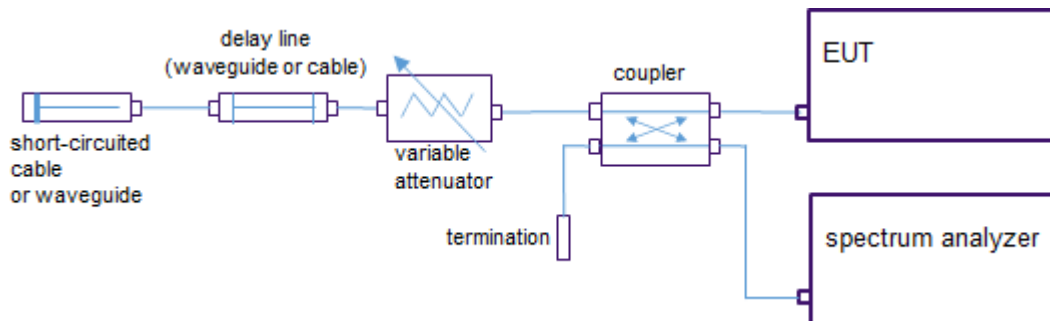

Figure 15: Conducted RBS test setup for radiodetermination applications

The power at the EUT ($P_{@EUT}$) can be calculated (see (equation (5))) as follows (see figure 16) out of the measurement.

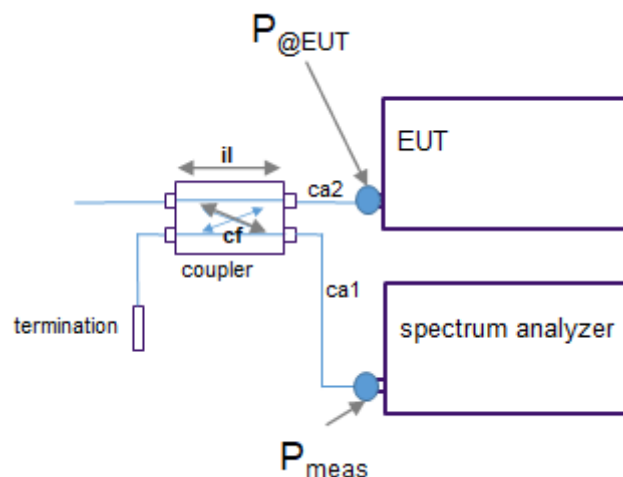

Figure 16: Calculation of the sensitivity @ EUT

$$P_{@EUT} = P_{meas} + ca1 + cf - il - ca2 \quad (5)$$

with:

- P_{meas} : measured received power in (similar to sensitivity level of the EUT or transmit power of the EUT).
- ca : cable attenuation in [dB].
- cf : coupling factor of the coupler in [dB].
- il : insertion loss of the coupler in [dB].
- $P_{@EUT}$: received power at the EUT (similar (type and limit) to sensitivity level of the EUT as specified in the related standard).

An alternative assessment/calculation without the use of a spectrum analyser is given in equation (6) and figure 17.

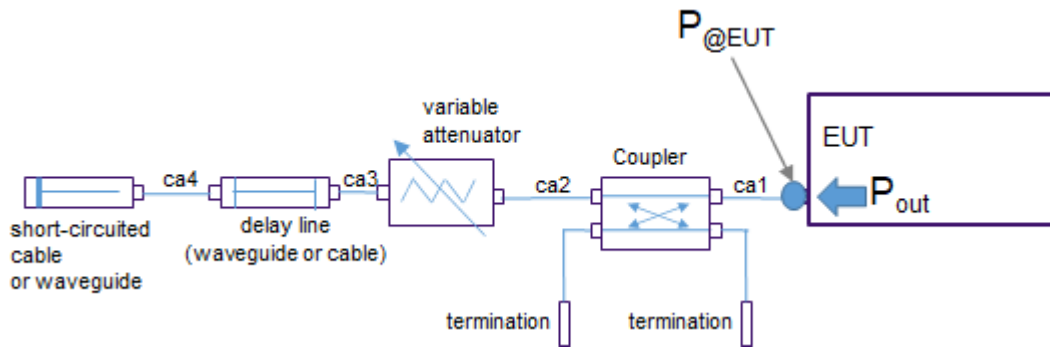

Figure 17: Calculation of the sensitivity @ EUT

$$P_{@EUT} = P_{out} - 2 \times (ca1 + ca2 + ca3 + ca4 + il + dl + att) \quad (6)$$

with:

- P_{out} : measured transmitted power in (dBm/MHz or dBm).
- caX: cable attenuation in [dB].
- il: insertion loss of the coupler in [dB].
- dl: attenuation of the "Delay Line" in [dB].
- att: attenuation of the "Variable Attenuator" in [dB].

The variable attenuator shall be adjusted according to one of the following options:

- Option 1: Adjust the power at the EUT with the variable attenuator until the received power at the EUT is equal to or less the sensitivity requirement as assessed in step 2 (clause 5.4.3.6.2) specified in the related standard. The wanted technical performance criterion (which shall be provided in the related standard), shall be then measured and recorded.
- Option 2: Adjust the power at the EUT with the variable attenuator until the technical performance criterion is just achieved; then measure the power at the EUT antenna port.

5.4.3.6.4 Step 4: Wanted Technical Performance Criteria Assessment

The test is passed, if the wanted technical performance criteria and the sensitivity limit are met, see related standard.

5.5 Receiver Baseline Resilience (RBR)

5.5.1 Description

Receiver Baseline Resilience (RBR) is defined as the capability to maintain a pre-determined minimum acceptable level of performance in the presence of unwanted signals in the frequency band of operation, applicable adjacent and remote frequency bands.

5.5.2 RBR Requirements

5.5.2.1 Interferer test signal

If nothing is specified in the related standard, then the test signals described in clause A.2 shall be used.

5.5.2.2 RBR wanted performance criteria

The RBR wanted performance criteria shall be specified in the related standard.

5.5.3 Conformance

5.5.3.1 General

For the RBR conformance test the RBS measurement shall be used as starting point. Table 8 below shows the relationship between RBS (see clause 5.4.3.1; table 7) and RBR tests.

Table 8: Overview of RBS and RBR measurement procedures

	Radio communication applications			Radiodetermination applications	
	Available	Not available (integral antenna)		Not available (integral antenna)	Available
Antenna connector (temporary or permanent)	Available	Not available (integral antenna)		Not available (integral antenna)	Available
Transmitter for RX tests with adjustable TX power. See note.	NA	Available	Not available	NA	NA
Test scenario	Conducted	Radiated	Radiated	Radiated	Conducted
RBS Conformance tests	Clause 5.4.3.2	Clause 5.4.3.3	Clause 5.4.3.4	Clause 5.4.3.5	Clause 5.4.3.6
RBR Conformance tests	Clause 5.5.3.2	Clause 5.5.3.3	Clause 5.5.3.4	Clause 5.5.3.5	Clause 5.5.3.6

NOTE: TX signal of the same EUT or separate signal generator/companion device.

5.5.3.2 Conducted Measurements for Radio Communication Devices

5.5.3.2.1 Step 1: Start with the RBS Setup

The RBR measurement should continue where the RBS measurement has stopped in clause 5.4.3.2.

5.5.3.2.2 Step 2: Adding Interfering Signal Source

Add the interfering signal source to the conformance RBS test set-up (see figure 18).

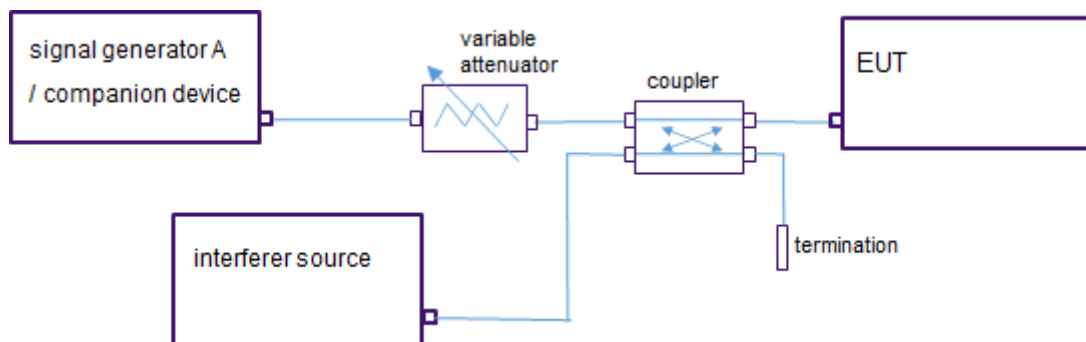

Figure 18: Conducted RBR test set-up for communication

The output power of the interfering source shall be calculated that the interferer power level at the EUT is as specified in clause 5.5.2. For power level calculation, see clause A.3.

5.5.3.2.3 Step 3: Degradation of Sensitivity Requirement

A degradation of the sensitivity d_g in dB should be specified in the related standard. If nothing is specified in the related standard a value of 3 dB shall be used.

5.5.3.2.4 Step 4: Test of Wanted Technical Performance Criteria

- Switch on EUT and Signal generator A/companion device.
- Check if EUT is working as intended (see RBS test).
- Switching on Interferer source with signals as specified in clause 5.5.2.

- Measure and record the technical performance criteria at the EUT.

Two methods are now possible:

- Option 1: Increase the power at the EUT with the variable attenuator to a value of sensitivity + d_g from step 3 (see clause 5.5.3.2.3).
- Option 2: Adjust the power at the EUT with the variable attenuator until the technical wanted performance criteria is just achieved; then measure the power at the EUT antenna port.

5.5.3.2.5 Step 5: Measurement Assessment

The test is passed, if the technical wanted performance criteria and the RBR limits are met, see related standard.

5.5.3.2.6 Step 6: Repetition of steps 4 and 5

Repetition of steps 4 and 5 for each interfering signal as specified in clause 5.5.2.

5.5.3.3 Radiated Measurements for Radio Communication Devices with Power Limit

5.5.3.3.1 Step 1: Start with the RBS Setup

The RBR measurement should continue where the RBS measurement has stopped in clause 5.4.3.3.

The same orientation between EUT and test antenna shall be kept.

5.5.3.3.2 Step 2: Adding Interfering Signal Source

Add the interfering signal source to the conformance RBS test set-up (see figure 19a and figure 19b). Figure 19b provides an alternative test set-up for scenarios if:

- Transmit test antenna and interfering transmit antenna cannot be arranged within the main beam of the EUT antenna pattern.

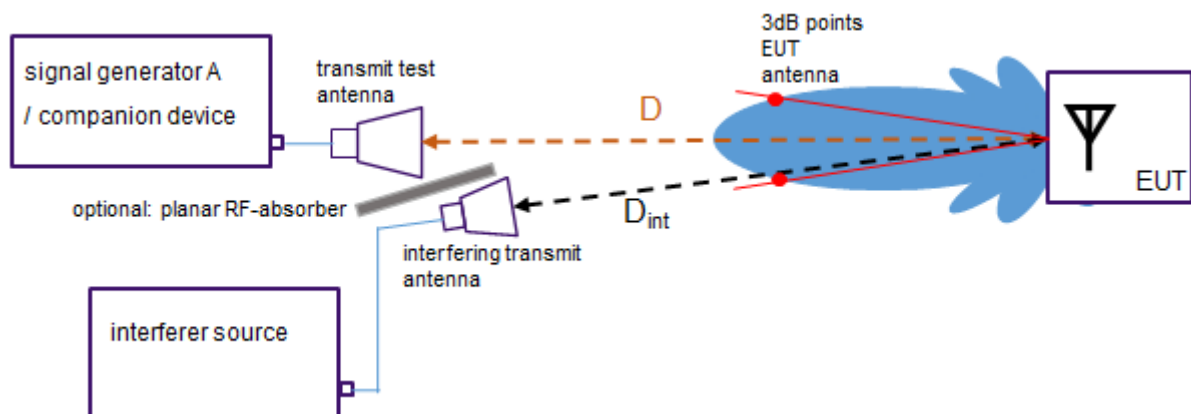

NOTE: The planar RF-absorber is optional to reduce the cross talk between transmit test antenna and interfering transmit antenna. If such planar RF-absorber will be used, the power levels (transmit and interfering signal) at the EUT shall be checked again, see clause 5.4.3.3.2, figure 10.

Figure 19a: Radiated RBR test set-up for communication

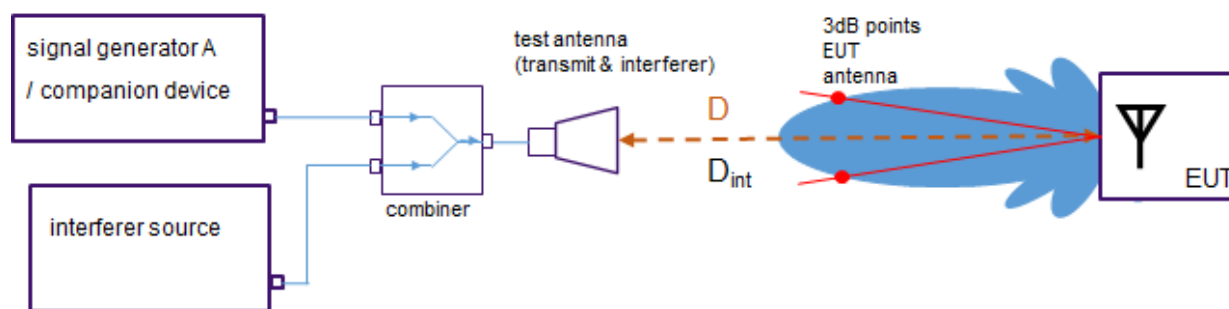

Figure 19b: Radiated RBR test set-up for communication with combiner

The antenna causing the interfering signal (interfering transmit antenna) shall be adjusted/placed in such way that:

- the main beam direction is pointing towards the EUT;
- the interfering signal is within the half-power BeamWidth of the EUT; (see description in ETSI EN 303 883-1 [1], clause 5.12.1);
- D_{int} is large enough that the EUT is within the farfield of the test antenna for the interfering signal.

NOTE: To assess farfield conditions see description in ETSI EN 303 883-1 [1], clause B.2.3.5.

The output power of the interfering source and D_{int} shall be calculated that the interferer power level at the EUT is as specified in clause 5.5.2. For power level calculation, see clause A.3.

If the test set-up as shown in figure 19b will be used, the additional attenuation of the combiner and possible additional cables need to be considered. For the signal generator A/companion device this could be by increasing the transmit power or by reduction of the distance compared to RBS test set-up. For the interfere source signal this could be considered by increasing the power level (to compensate the additional attenuation) compared to the calculation in clause A.3.

5.5.3.3.3 Step 3: Degradation of Sensitivity Requirement

A degradation of the sensitivity d_g in dB should be specified in the related standard. If nothing is specified in the related standard a value of 3 dB shall be used.

5.5.3.3.4 Step 4: Test of Wanted Technical Performance Criteria

- Switch on EUT and Signal generator A/companion device.
- Check if EUT is working as intended (see RBS test).
- Switch on Interferer source with signals as specified in clause 5.5.2.
- Measure and record the technical performance criteria at the EUT.

Assessment:

- Increase the power at the EUT to a value of sensitivity + d_g from step 3 (e.g. at the signal generator A/companion device and/or by changing the distance D).

5.5.3.3.5 Step 5: Measurement Assessment

The test is passed, if the technical wanted performance criteria and the RBR limits are met, see related standard.

5.5.3.3.6 Step 6: Repetition of steps 4 and 5

Repetition of steps 4 and 5 for each interfering signal as specified in clause 5.5.2.

5.5.3.4 Radiated Measurements for Radio Communication Devices with Distance Limit

5.5.3.4.1 Step 1: Start with the RBS setup

The RBR measurement should continue where the RBS measurement has stopped in clause 5.4.3.4.

The same orientation between EUT and test antenna shall be kept.

5.5.3.4.2 Step 2: Adding interfering signal source

Add the interfering signal source to the conformance RBS test set-up (see figure 20a and figure 20b). Figure 20b provides an alternative test set-up for scenarios if:

- Transmit test antenna and interfering transmit antenna cannot be arranged within the main beam of the EUT antenna pattern.

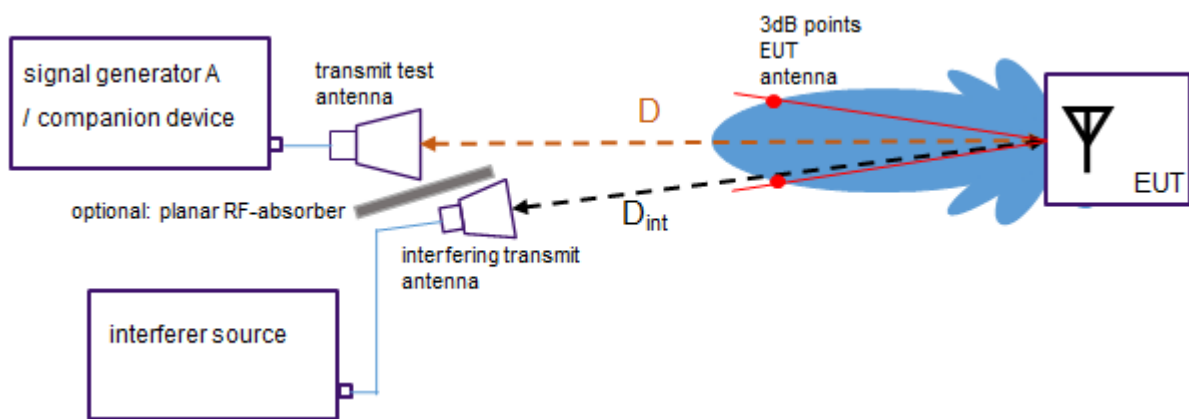

Figure 20a: Radiated RBR test set-up for communication

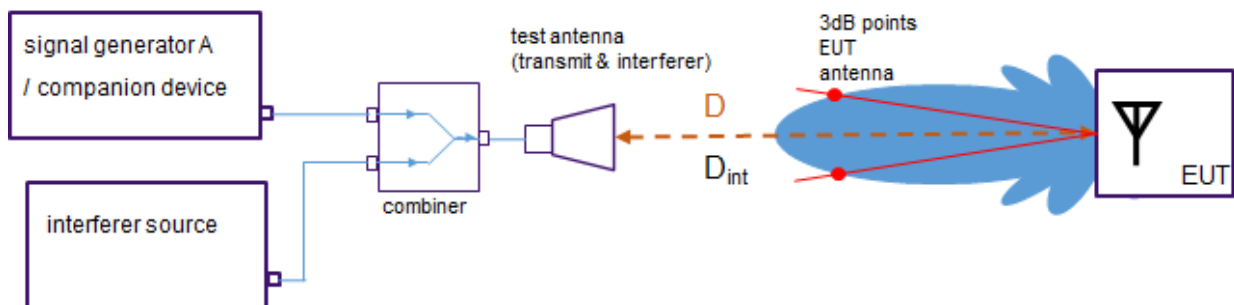

Figure 20b: Radiated RBR test set-up for communication with combiner for transmit and interferer signal

The antenna causing the interfering signal shall be adjusted/placed in such way that:

- the main beam direction is pointing towards the EUT;
- the interfering signal is within the half-power BeamWidth of the EUT; (see description in ETSI EN 303 883-1 [1], clause 5.12.1);
- D_{int} is large enough that the EUT is within the farfield of the test antenna for the interfering signal.

NOTE: To assess farfield conditions see description in ETSI EN 303 883-1 [1], clause B.2.3.5.

The output power of the interfering source and D_{int} shall be calculated that the interferer power level at the EUT is as specified in clause 5.5.2. For power level calculation, see clause A.3.

If the test set-up as shown in figure 20b will be used, the additional attenuation of the combiner and possible additional cables need to be considered. For the signal generator A/companion device this could be by increasing the transmit power or by reduction of the distance compared to RBS test set-up. For the interfere source signal this could be considered by increasing the power level (to compensate the additional attenuation) compared to the calculation in clause A.3.

5.5.3.4.3 Step 3: Degradation of Sensitivity Requirement

A degradation ΔD of the distance as assessed in the related step 2 of the RBS test (see clause 5.4.3.4.2) should be specified in the related standard. If nothing is specified in the related standard a value of 30 % from the distance in step 2 of the RBS (clause 5.4.3.4.2) test shall be used as ΔD .

The context for the distance is shown in equation (7):

$$D = D_{\text{sense/scal}} - \Delta D \quad (7)$$

with:

- D: Distance for the test.
- $D_{\text{sense/scal}}$: Distance from RBS measurement see clause 5.4.3.4.2.
- ΔD : Degradation of the distance from RBR test, measurement see clause 5.5.3.4.3.

5.5.3.4.4 Step 4: Test of Wanted Technical Performance Criteria

- Switch on EUT and Signal generator A/companion device.
- Check if EUT is working as intended (see RBS test).
- Switch on Interferer source with signals as specified in clause 5.5.2.
- Measure and record the technical wanted performance criteria at the EUT.

Two methods are now possible:

- Option 1 (recommended method): Decrease the distance D, see equation (7); measure and record the technical wanted performance criteria.
- Option 2: Adjust the distance D until the technical performance criterion is just achieved; record distance D. For this option the measured distance shall be larger than the distance limit in step 3 of the test (see clause 5.5.3.4.3).

5.5.3.4.5 Step 5: Measurement Assessment

The test is passed, if the technical wanted performance criteria and the RBR limits are met, see related standard.

5.5.3.4.6 Step 6: Repetition of steps 4 and 5

Repetition of steps 4 and 5 for each interfering signal as specified in clause 5.5.2.

5.5.3.5 Radiated Measurements for Radiodetermination Applications with Distance Limit

5.5.3.5.1 Step 1: Start with the RBS Setup

The RBR measurement should continue where the RBS measurement has stopped in clause 5.4.3.5.

5.5.3.5.2 Step 2: Adding interfering signal source

Add the interfering signal source to the conformance RBS test set-up (see figures 21 and 22).

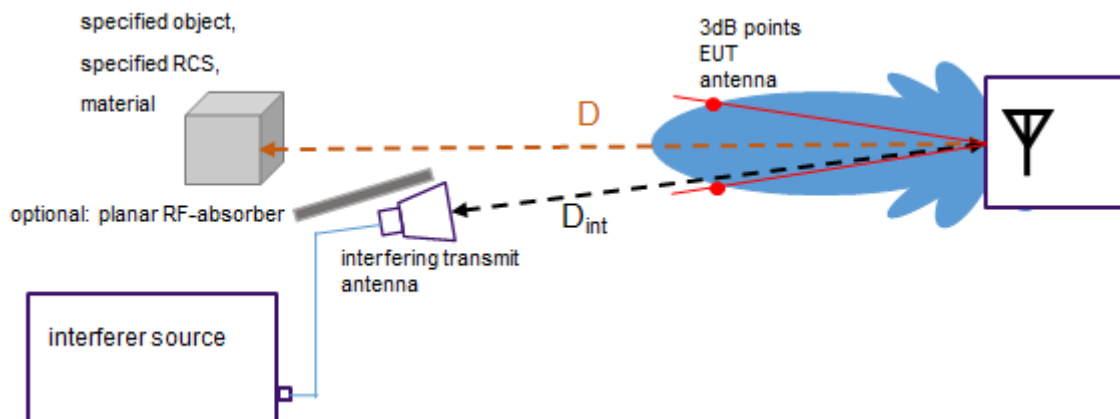

Figure 21: Radiated RBR test set-up for radiodetermination via free space

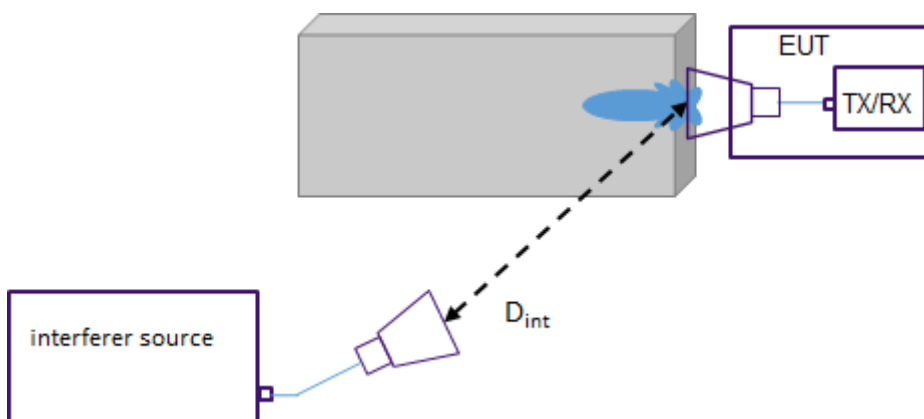

Figure 22: Radiated RBR test set-up for contact-based radiodetermination

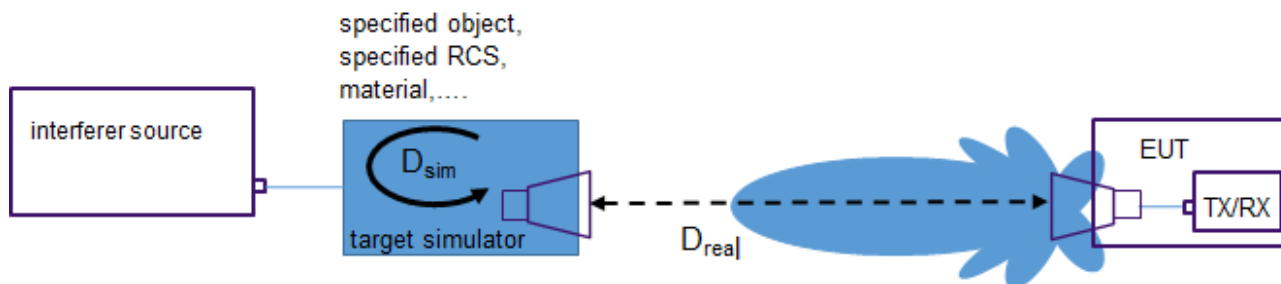

Figure 23: Radiated RBR test set-up for radio determination via free space and target simulator

The antenna causing the interfering signal shall be adjusted/placed in such way that:

- the main beam direction is pointing towards the EUT;
- the interfering signal is within the half-power BeamWidth of the EUT; (see description in ETSI EN 303 883-1 [1], clause 5.12.1).
- For contact-based radio determination EUT (see figure 22), the "position" of the Interfering Source shall be specified in the related standard.
- For test set-up using a target simulator (see figure 23) the interferer source can directly be connected to the target simulator (see ETSI TS 103 788 [i.10]). To adjust the specified interferer signal power level at the EUT, see manual of the target simulator.
- D_{int} is large enough that the EUT is within the farfield of the test antenna for the interfering signal.

NOTE: To assess farfield conditions see description in ETSI EN 303 883-1 [1], clause B.2.3.5

The output power of the interfering source and the D_{int} shall be calculated that the interferer power level at the EUT is as specified in clause 5.5.2. For power level calculation, see clause A.3.

5.5.3.5.3 Step 3: Degradation of Sensitivity Requirement

A degradation ΔD of the distance as assessed in the related step 2 of the RBS (see clause 5.4.3.5.2) test should be specified in the related standard. If nothing is specified in the related standard a value of 30 % shall be used as ΔD .

The context for the distance is shown in equation (8):

$$D = D_{\text{sense/scal}} - \Delta D \quad (8)$$

with:

- D: Distance for the test.
- $D_{\text{sens/scal}}$: Distance from RBS measurement see clause 5.4.3.5.2.
- ΔD : Degradation of the distance from RBR test, measurement see clause 5.5.3.5.3.

5.5.3.5.4 Step 4: Test of Wanted Technical Performance Criteria

- Switch on EUT.
- Check if EUT is working as intended (see RBS test).
- Switch on Interferer source with signals as specified in clause 5.5.2.
- Measure and record the technical performance criteria at the EUT.

Two methods are now possible:

- Option 1 (recommended method): Decrease the distance D to $D_{\text{sense/scal}} - \Delta D$ (see equation (8)); measure and record the performance criterion.
- Option 2: Adjust the distance D until the technical performance criterion is just achieved; record distance D. For this option the measured distance shall be larger than the distance limit in step 3.

5.5.3.5.5 Step 5: Measurement Assessment

The test is passed, if the technical wanted performance criteria and the RBR limits are met, see related standard.

5.5.3.5.6 Step 6: Repetition of steps 4 and 5

Repetition of steps 4 and 5 for each interfering signal as specified in clause 5.5.2.

5.5.3.6 Conducted Measurements for Radio Determination Devices

5.5.3.6.1 Step 1: Start with the RBS Setup

The RBR measurement should continue where the RBS measurement has stopped in clause 5.4.3.6.

5.5.3.6.2 Step 2: Adding Interfering Signal Source

Add the interfering signal source to the conformance RBS test set-up (see figure 24).

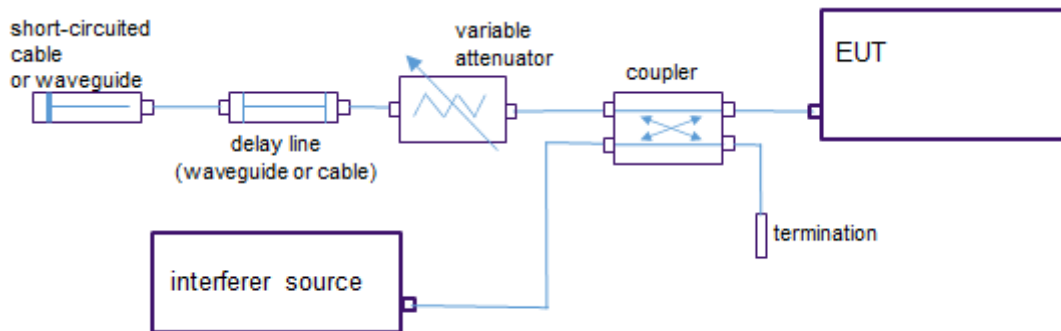

Figure 24: Conducted RBR test set-up for radiodetermination

The output power of the interfering source shall be calculated that the interferer power level at the EUT is as specified in clause 5.5.2. For power level calculation, see clause A.3.

5.5.3.6.3 Step 3: Degradation of Sensitivity Requirement

A degradation of the sensitivity d_g in dB should be specified in the related standard. If nothing is specified in the related standard a value of 3 dB shall be used.

5.5.3.6.4 Step 4: Test of Wanted Technical Performance Criteria

- Switch on EUT.
- Check if EUT is working as intended (see RBS test).
- Switch on Interferer source with signals as specified in clause 5.5.2.
- Measure and record the technical performance criteria at the EUT.

Two methods are now possible:

- Option 1: Increase the power at the EUT with the variable attenuator to a value of the sensitivity requirement as assessed in step 3, (clause 5.5.3.6.3).
- Option 2: Adjust the power at the EUT with the variable attenuator until the technical performance criterion is just achieved; then measure the power at the EUT antenna port.

5.5.3.6.5 Step 5: Measurement Assessment

The test is passed, if the technical wanted performance criteria and the RBR limits are met, see related standard.

5.5.3.6.6 Step 6: Repetition of steps 4 and 5

Repetition of steps 4 and 5 for each interfering signal as specified in clause 5.5.2.

Annex A (normative): Choose interferer for RBR

A.1 Introduction

Annex A provides a procedure to select the necessary "interfering" test signals for the RBR assessment. The justification for the selected receiver requirements and interfering signals is provided in annex C.

The RBR tests are split into tests within OFR (see clause A.2.1) and outside OFR (see clause A.2.2).

For the RBR in-band tests (see clause A.2.1) the number of interfering test signals is dependent on the OFR of the EUT:

- for EUT with OFR < 500 MHz: at least one interferer, see figure A.1;
- for EUT with OFR \geq 500 MHz: three interferer, see figure A.2.

The reason for this approach is that the probability of a radio receiver to get interfered from other radio users is closely linked with the OFR of the EUT. The larger the OFR of the EUT is, the higher the probability that the EUT will be interfered. To account for that the number of interfering signals was increased to three for a higher OFR.

This approach was developed in ETSI TS 103 361 [i.4] and is still valid. The 500 MHz was chosen because of the FCC definition of UWB having an OFR of at least 500 MHz (see clause 4.2 of ETSI EN 303 883-1 [1]). For the RBR-test the OFR of the TX measurement shall be taken (see clause 5.2 in ETSI EN 303 883-1 [1]).

For the RBR tests outside OFR the test signals are generally put to $f_c \pm$ OFR (to account for adjacent interferers, e.g. similar to ACS) and $f_c + 2x$ OFR (to account for further away interferers, e.g. similar to blocking).

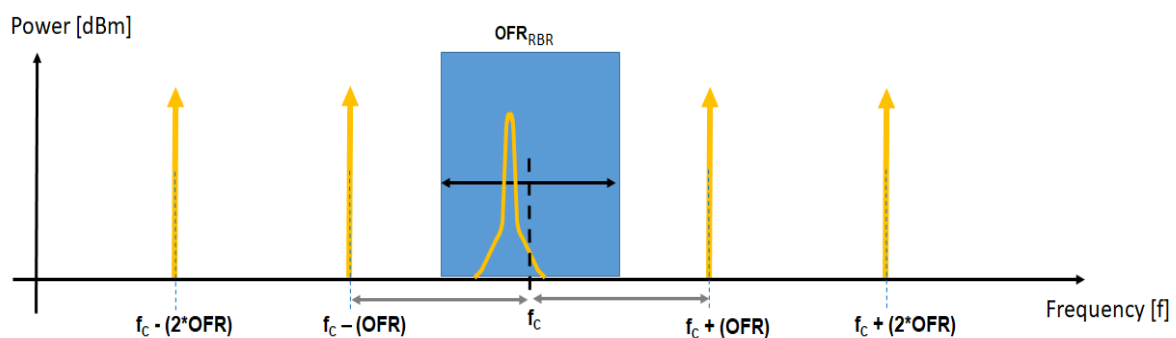

Figure A.1: Frequencies for the RBR tests based on option 1

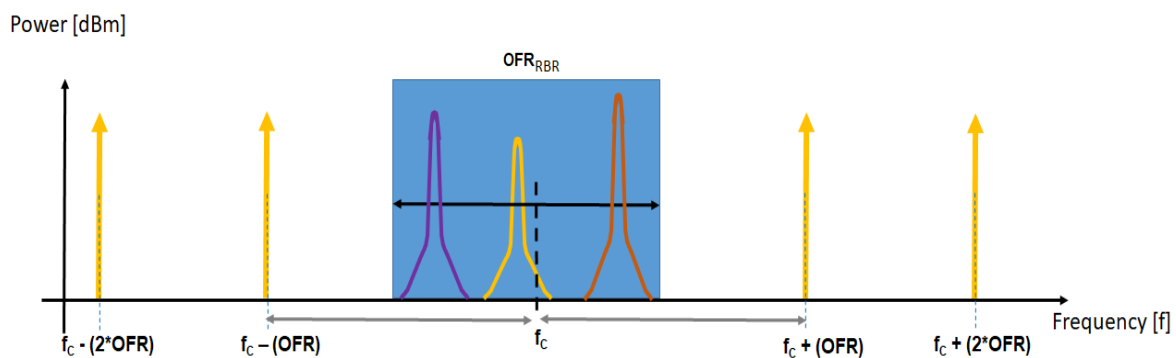

Figure A.2: Frequencies for the RBR tests based on option 2

A.2 Limits for the Interfering Signals

A.2.1 Interferer within OFR

A.2.1.0 Introduction

If not otherwise specified in the related standard, then one of the following two approaches shall be used in the related standard:

- Option 1 in clause A.2.1.1 uses the approach from ETSI TS 103 361 [i.4].
- Option 2 in clause A.2.1.2 is a simplified approach which was developed based on the experience with ETSI TS 103 361 [i.4], where the selection of frequency and power for the test signals requires a huge effort and the availability of very complex lists of all possible interfering signals and for all possible applications. The selection of interferer frequencies and power levels in this clause are applicable for all frequency ranges and applications. The assumed interferer power level in this clause (100 mW e.i.r.p. at 2 m under line of sight conditions with 10 dB additional losses) was derived from a detailed analysis of ETSI TS 103 361 [i.4] and it represents a worst case interfering signal compared to ETSI TS 103 361 [i.4].

A.2.1.1 Option 1

The assessment procedure in ETSI TS 103 361 [i.4] shall be used in the following way:

- The interferer test frequency range shall be the OFR (as derived from the TX requirements of the EUT) and not as specified in clause 9.1.2 of ETSI TS 103 361 [i.4].
- Depending the OFR (see clause A.1):
 - For $\text{OFR} < 500 \text{ MHz}$: at least the highest interferer shall be assessed.
 - For $\text{OFR} \geq 500 \text{ MHz}$: the three highest interferer shall be assessed.

NOTE: Depending on the assessment and the allocations within the OFR it could that there are less than possible three interferers present. In this case, all possible interferers are assessed.

- The assessment/selection of interferers (frequency, power, modulation, duty cycle) shall be as given in clause 9.3 of ETSI TS 103 361 [i.4]. If not otherwise specified in the related standard, then the configuration of each test signal shall be as provided in clause 8 of ETSI TS 103 361 [i.4] and the related standard shall specify which option in that clause (CW, wideband, duty-cycled or real interferer) shall be used for the test signal.
- The related standard shall specify which application class in clause 7 of ETSI TS 103 361 [i.4] is relevant to the device under test (i.e. indoor, outdoor, mobile (indoor/outdoor), level-probing/tank-level-probing or automotive)

If in ETSI TS 103 361 [i.4] no information is available for radio application within OFR, then the related standard shall provide this information (e.g. the EFIS [i.8] database could be consulted at <https://efis.cept.org/>).

The result of the interferer assessment shall be documented inside the technical documentation file, see Directive 2014/53/EU [i.7], article 21.

A.2.1.2 Option 2

If not otherwise specified in the related standard, then the following values shall be used:

- Interferer test frequencies are dependent on the OFR (see further information in clause A.1):
 - For $\text{OFR} < 500 \text{ MHz}$: at f_C .
 - For $\text{OFR} \geq 500 \text{ MHz}$: at f_C and $f_C \pm 0,3 \times \text{OFR}$.

- Level of Interferer signal:
 - For equipment with integral antenna and without access to the EUT antenna port the field strength at EUT shall be 0,27 V/m.

NOTE 1: The above value was calculated with the following equation (A.1):

$$E \left[\frac{V}{m} \right] = \sqrt{\frac{0,1 [W] \times 0,1 \times 377 [Ohm]}{4 \times \pi \times 2 [m]^2}} \quad (A.1)$$

it assumes an interferer with 100 mW e.i.r.p. at 2 m distance under line of sight conditions with 10 dB additional losses.

- For equipment with access to the EUT antenna port the power at EUT shall be calculated with the following equation (A.2):

$$P_e [dBm] = 20 [dBm] - 32,5 d - 20 \log(f [GHz]) - 20 \log(2 [m]) - 10 [dB] \quad (A.2)$$

NOTE 2: The above equation (A.2) assumes an interferer with 100 mW e.i.r.p. at 2 m distance under line of sight conditions with 10 dB additional losses with an assumed Rx antenna gain of 0 dBi; the formula gives -28,5 dBm at 1 GHz, -48,5 dBm at 10 GHz, -68,5 dBm at 100 GHz.

NOTE 3: The above limits are equivalent for an RX antenna gain of 0 dBi.

- Interferer modulation: CW.

The result of the interferer assessment shall be documented inside the technical documentation file.

A.2.2 Interferer outside OFR

If nothing different is specified in the related standard the following values shall be taken:

- Interfering signal @ $f_c \pm (X) \times \text{OFR}$ with $X = 1 \ \& \ 2$ (if not otherwise specified in the related standard).
- Modulation of interfering signal: CW (if not otherwise specified in the related standard).
- Level of interfering signal based on the intended use: to be specified in the related standard (e.g. considering ETSI TS 103 361 [i.4]).
- For the calculated frequency of interferer below f_c (Interfering signal @ $f_c - (X \times \text{OFR})$) it could be that the test frequency is very low or even below 0 Hz. Only test frequencies above 30 MHz shall be considered. For frequencies below 30 MHz, the immunity of the EUT will be assessed based on the required assessment outlined in Directive 2014/53/EU [i.7], article 3.1(b).

A.3 Guidance to Setup the Power Level of the Interfering Signals @ EUT for RBR tests

A.3.1 Radiated tests

The radiated "interfering" path could be seen as shown in figure A.3.

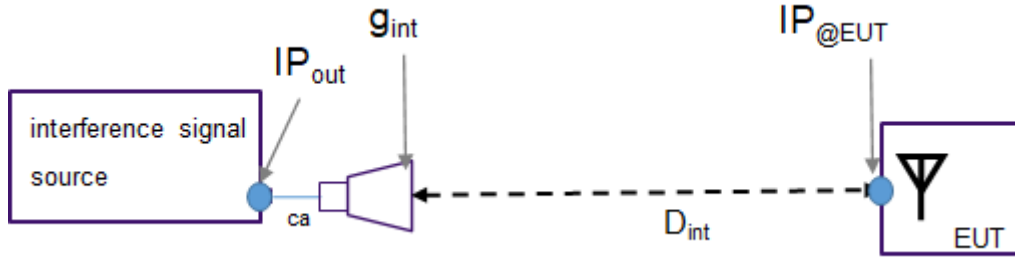

Figure A.3: Radiated scenario for RBR interferer assessment

A certain interfering Power@EUT ($IP_{@EUT}$) with a interfering transmit antenna (G_{int}) with gain g_{int} and a distance D_{int} between interfering transmit antenna and EUT can be achieved by setting the interference signal source generator to the power IP_{out} (see figure A.3) according to equation (A.3).

$$IP_{out}[\text{dBm}] = IP_{@EUT}[\text{dBm}] + 20\log\left(4 \times \pi \times D_{int} \times \frac{f_c}{c}\right) - g_{int}[\text{dBi}] + ca[\text{dB}] \quad (\text{A.3})$$

with:

- f_c : is the centre frequency of the interferer [Hz].
- c : the velocity of light [m/s].
- D_{int} : distance between interfering signal source and the EUT during the test [m].
- g_{int} : antenna gain of test antenna to transmit interfering signal [dBi].
- ca : are cable losses in the test-set-up [dB].

NOTE 1: The above approach assumes an EUT antenna gain of 0 dBi.

The calculated output power for interfering signal source could be tested if the EUT will be replaced by a typical TX-emission set-up (measurement antenna and receiver). More information is available in ETSI EN 303 883-1 [1].

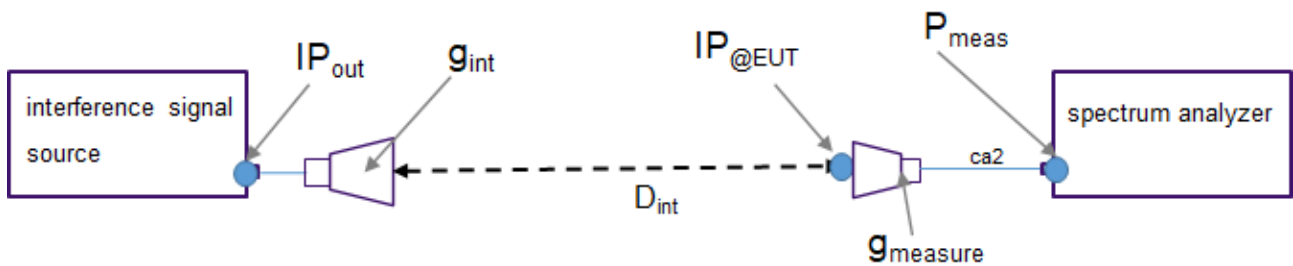

Figure A.4: Radiated set-up to evaluate interferer level at EUT

The correct interfering power levels @ EUT can be checked in the following way:

- Replace EUT by a known measurement antenna $g_{measure}$ and a spectrum analyser (see figure A.4).

NOTE 2: For measurement of radiated power see for information ETSI EN 303 883-1 [1], clause 5.3.

- Pointing the measurement antenna (with the antenna gain $g_{measure}$) to the interfering signal source (antenna gain g_{int}).
- Set-up the interfering signals source with the interfering signals at D_{int} .

To assess the interfering power level @ EUT (see equation (A.4)) following correction shall be considered:

$$IP_{@EUT} = P_{meas} + ca2 - g_{measure} \quad (\text{A.4})$$

with:

- P_{meas} : measured power at the spectrum analyser in [dBm].
- g_{measure} : measurement receiving test antenna gain in [dBi] at test frequency f .
- $ca2$: cable attenuation between receiving test antenna and spectrum analyser in [dB].

A.3.2 Conducted tests

- The received signal level from the interferer source could be checked with the test set-up for the sensitivity test in clauses 5.3.3.2 (communication) and 5.4.3.6 (radio determination).
- The output power of the interfering source shall be adjusted taking into account the coupling attenuation of the coupler and the cable attenuation, see figure A.5 and equation (A.5).

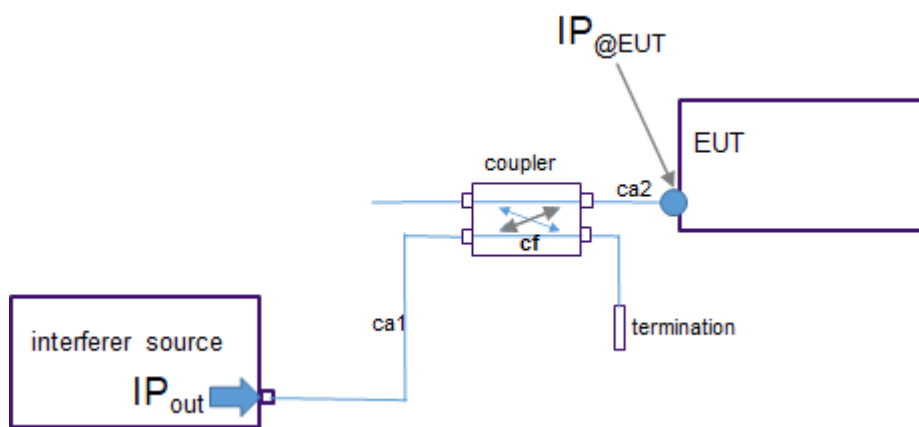

Figure A.5: Conducted RBR test set-up for radiodetermination

$$IP_{\text{out}} = IP_{\text{@EUT}} + ca1 + cf + ca2 \quad (\text{A.5})$$

NOTE: The interfering power at the EUT could also be tested by replacing the EUT with a measurement receiver (e.g. spectrum analyser).

Annex B (informative): Guidance on Scaling Receiver Sensitivity

B.1 General

The receiver sensitivity limit of a EUT can be scaled with the TX power of the same device or companion device according to the receiver baseline sensitivity in ETSI TS 103 567 [i.3].

This concept is proposed to be used to calculate the sensitivity limit either by scaling the power or the distance for devices which have lower transmit power for the function to comply the technical performance criteria specified in the related harmonised standard compared with the regulated limit. The detailed description how this approach can be considered in a harmonised standard is provided below.

B.2 Scaling of power at the EUT

The harmonised standard offers the following information:

- P_{reg} : regulated Tx power limit, related EUT regulation considered in the related standard (e.g. dBm/MHz, W, or dBm).
- RX_{ref} : reference sensitivity limit at the antenna port of the EUT [dBm].
- SCP: scaling factor (absolute value).

In addition, the actual emission of the EUT needs to be considered:

- P_{EUT} : measured transmitted power of the EUT (e.g. dBm/MHz, W, or dBm).

NOTE 1: P_{EUT} will be measured/considered based on the related (harmonised) standard (e.g. radio determination use-cases) or the transmitted power of a companion device (e.g. communication or tracking systems).

The scaled sensitivity limit (RX_{refsens}) for the RBS test is calculated according to equation (B.1) by using the TX power measurement result of the EUT (P_{EUT}):

$$RX_{\text{refsens}}[\text{dBm}] = RX_{\text{ref}}[\text{dBm}] + SCP \times 10 \log \left(\frac{P_{\text{reg}}[\text{W}]}{P_{\text{EUT}}[\text{W}]} \right) = RX_{\text{ref}}[\text{dBm}] + SCP \times (P_{\text{reg}}[\text{dBm}] - P_{\text{EUT}}[\text{dBm}]) \quad (\text{B.1})$$

NOTE 2: The related standard specifies which power limit and measurement result is used. If nothing is specified, the mean power spectral density in dBm/MHz e.i.r.p. limit and measurement result is used.

EXAMPLE:

- $RX_{\text{ref}} = -70$ dBm for P_{reg} limit of $-41,3$ dBm/MHz e.i.r.p.
- $SCP = 2$.
- With a P_{EUT} of $-44,3$ dBm/MHz.

With this information and equation (B.1) RX_{refsens} for the RBS test would be:

$$RX_{\text{refsens}} \text{ dBm} = -70 \text{ dBm} + 2 \times (-41,3 \text{ dBm/MHz} + 44,3 \text{ dBm/MHz}) = -64 \text{ dBm} \quad (\text{B.2})$$

B.3 Scaling distance

The harmonised standard offers the following information:

- P_{reg} : regulated Tx power limit, related EUT regulation considered in the related standard (e.g. dBm/MHz, W, or dBm).

- D_{sense} : reference distance between object or companion device and the EUT in [m].
- SCP: scaling factor (absolute value).

In addition, the actual emission of the EUT needs to be considered:

- P_{EUT} : measured transmitted power of the EUT [e.g. dBm/MHz, W, or dBm].

NOTE 1: P_{EUT} will be measured/considered based on the related (harmonised) standard (e.g. radio determination use-cases) or the transmitted power of a companion device (e.g. communication or tracking systems).

The scaled distance (D_{scal}) for the RBS test is calculated according to equation (B.3) by using the RP power measurement result of the EUT (P_{EUT}):

$$D_{\text{scal}} [\text{m}] = D_{\text{sense}} [\text{m}] \times 10^{\frac{-(P_{\text{reg}}[\text{dBm}] - P_{\text{EUT}}[\text{dBm}])}{\text{SCP}}} \quad (\text{B.3})$$

NOTE 2: The related standard specifies which power limit and measurement result is used. If nothing is specified, the mean power spectral density in dBm/MHz e.i.r.p. limit and measurement result is used.

EXAMPLE:

- $D_{\text{sense}} = 10$ m for P_{reg} limit of -41,3 dBm/MHz e.i.r.p.
- SCP = 20.
- With a P_{EUT} of -44,3 dBm/MHz.

With this information and equation (B.3) D_{scal} for the RBS test would be:

$$D_{\text{scal}} [\text{m}] = 10 \text{ m} \times 10^{\frac{-\left(-41,3 \frac{\text{dBm}}{\text{MHz}} + 44,3 \frac{\text{dBm}}{\text{MHz}}\right)}{20}} = 7,07 \text{ m} \quad (\text{B.4})$$

Annex C (informative): Justification of receiver requirements from ETSI EG 203 336

C.1 General

Parameter of the (baseline) RX requirement concept:

- Receiver Baseline Sensitivity (RBS): is the capability to receive a wanted signal at application related defined input signal levels while providing a pre-determined minimum acceptable level of technical performance.
- Receiver Baseline Resilience (RBR): is defined as the capability to maintain a pre-determined minimum acceptable level of performance in the presence of unwanted signals over the frequency band of operation, applicable adjacent and remote frequency bands.

Application notes:

- The purpose of the RBR requirement is to assure a basic measure of interference robustness; its value should be consistent with the state-of-the-art technologies making use of RF transmission.
- The underlying assumption is that a poor RBR value at any frequency indicates a poor receiver design that is not spectrum efficient.
- The level(s) of the unwanted signal(s) and the frequency of their sources is usually given in radio compatibility studies; such studies usually make assumptions about the robustness of victim receivers.
- The unwanted signal levels can be specified as an absolute value or as relative values, e.g. as the difference between the wanted and the unwanted signals. The specification is the responsibility of the relevant Technical Body and includes the assumed coexistence scenarios for the application covered in the related (harmonised) standard.

C.2 Justification

These parameters were assessed compared to the RX-requirements in ETSI EG 203 336 [i.1] and the outcome of ETSI STF 494 (ETSI TS 103 361 [i.4]) and ETSI STF 541 (ETSI TS 103 567 [i.3]). The assessment result and summary for a justification of the baseline receiver concept is provided in table C.1.

Table C.1: Justification of RX-requirements in relation to new baseline Rx-requirement

RX parameter in ETSI EG 203 336 [i.1]	Applicable/tested	Justification
Sensitivity	Covered by RBS	See Baseline Sensitivity requirement. A justification for radio determination applications is provided in clause C.4.
Co-channel rejection	Covered by RBR	Based on ETSI TS 103 567 [i.3], this requirement/effect is covered by a specified "interfering" signal within OFR (see annex A) or specified signal in the related standard. This in-band interfering test with a realistic signal can be seen as the worst case for intermodulation, spurious response rejection and reciprocal mixing. The used interfered power is significantly higher than any expected effect caused by intermodulation, spurious response rejection and reciprocal mixing within the receiver.
Adjacent channel selectivity (ACS)	Covered by RBR	Based on ETSI TS 103 567 [i.3], this requirement/effect is covered by a specified "interfering" signal adjacent to OFR (see annex A e.g. @ $f_c \pm \text{OFR}$) or specified signal in the related standard.
Blocking	Covered by RBR	Based on ETSI TS 103 567 [i.3], this requirement/effect is covered by a specified "interfering" signal at specified frequencies (see annex A) or directly specified signal in the related standard.
Intermodulation	Covered by RBR	Based on ETSI TS 103 567 [i.3] and the definition of Intermodulation the effect is not relevant for EUT using this RX-concept (RBS/RBR). In ETSI Guide there was direct in-band test. Only the intermodulation requirement was for evaluating interfering signals @ f_c of RX (within OFR). But with the direct in-band interferer test in the RBR requirement it will be checked in which way the EUT can handle signals within OFR. Therefore, the effect of intermodulation is tested with the in-band interferer.
Spurious response rejection	Covered by RBR	With the direct in-band interferer test in the RBR requirement it will be checked in which way the EUT can handle signals within OFR. RBR requirement require tests with the highest "interfering" signal within the OFR and the physical effect that a spurious response rejection of signals within the RX will be not higher (in power) compared to the highest interfering signals this test is not necessary. Therefore, effects based on the spurious response are tested with the in-band interferer tests. See ETSI TS 103 567 [i.3].
Dynamic range	Partly covered by RBS	Dynamic range comprises the highest and lowest receiving signal at the EUT. The lowest receiving signal is related to the Sensitivity limit of the receiver and therefore covered by the RBS test. The knowledge about the highest possible receiving signal of the EUT does not provide any additional information about the spectrum efficient use. This parameter provides only information about the kind and the quality of the receiver. Due to the low TX-power for typical UWB EUT the Dynamic range test can be replaced by the RBS test. In addition, the RBR test with the highest in-band interferer provided information about the non-linearity based on high receiving signal levels. But if the dynamic range requirement is important based on the technical wanted performance criteria/use-case of the EUT, the related standard therefore specifies a set of parameters with the related conformance test set-up to create the maximum signal at the receiver. For the Dynamic range test the same setup as for the RBS requirement assessment can be used.
Desensitization (In-band signals)	Covered by RBR	Covered by an interfering signal in-band (within OFR).
Reciprocal Mixing	Covered by RBR	With the direct in-band interferer test in the RBR requirement it will be checked in which way the EUT can handle signals within OFR. RBR requirement require tests with the highest "interfering" signal within the OFR and the physical effect that a intermodulation of signals within the RX will be not higher (in power) compared to the highest interfering signals this test is not necessary. Therefore, effects based on the reciprocal mixing are tested with the in-band interferer tests. See ETSI TS 103 567 [i.3].

C.3 Summary for the RBR requirement

The highest interfering signal **within** OFR during the RBR test could replace following receiver requirements from the ETSI EG 203 336 [i.1]:

- desensitization;
- co-channel rejection;
- intermodulation;

NOTE 1: The three highest interfering signals (see annex A) could have a higher power level compared to a "similar" signal use for RX-requirements in the ETSI EG 203 336 [i.1] and therefore the impact/interference to the receiver could be larger.

- reciprocal mixing; and
- spurious response rejection

NOTE 2: In-band interfering test with a realistic signal can be seen as the worst case for intermodulation, spurious response rejection and reciprocal mixing. The used interfered power is significantly higher than any expected effect caused by intermodulation, spurious response rejection and reciprocal mixing within the receiver.

Specified CW signals @ specified frequencies (see figure A.1 and figure A.2) during the RBR test could replace following requirements from the ETSI EG 203 336 [i.1] and could therefore replace:

- Adjacent Signal Selectivity.
- Blocking.

NOTE 3: The power of the CW interferer and @ which frequency the interferer has to be placed will be specified in the related standard or as an alternative a typical interfering signal could be taken see procedure in annex A.

Summary mapping/replacement (see table C.2) of the baseline receiver requirements in relation with the RX-requirements described in ETSI EG 203 336 [i.1] and the assessment in ETSI TS 103 567 [i.3].

Table C.2: Mapping RX - requirement from ETSI EG 203 336 [i.1] and ETSI TS 103 567 [i.3] with baseline RX-requirements

RX-requirements ETSI EG 203 336 [i.1]	Baseline RX Requirement		Comment
	RBS	RBR	
Sensitivity	X		Sensitivity test could be replaced by dynamic range assessment, is specified in the related standard
Co-channel rejection		X	Interferer within OFR
Adjacent channel selectivity		X	Interferer @ $f_c \pm$ OFR
Blocking		X	Interferer @ $f_c \pm 2 \times$ OFR
Intermodulation		X	Interferer within OFR
Spurious response rejection		X	Interferer within OFR
Desensitization (In-band signals)		X	Interferer within OFR
Reciprocal Mixing		X	Interferer within OFR

NOTE 4: If Active Mitigation, like LBT, DAA or TPC (for more info see ETSI TR 103 181-2 [i.6]) is used there is no need for a specific RX-test within OFR.

C.4 Justification RBS-requirement for radio determination devices

The clause provides the technical theoretical background to justify the RBS requirement for radio determination use-cases based on a specified object (with radar cross section) @ a specified distance. These specifications are directly linked with the "estimated" received power at the EUT.

The RCS of a radar target is the hypothetical area required to intercept the transmitted power density at the target such that if the total intercepted power were re-radiated isotropically, the power density actually observed at the receiver is produced. This is a complex statement that can be understood by examining the monostatic (radar transmitter and receiver co-located, see figure C.1).

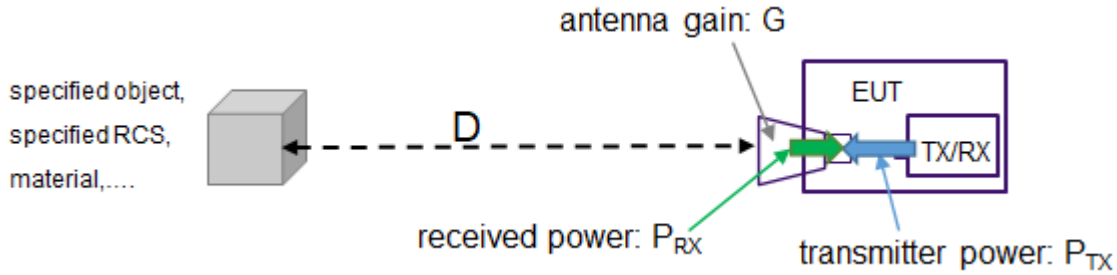

Figure C.1: Scenario for RBS justification for radio determination applications

The related radar equation (see equation (C.1)) could be written as:

$$P_{RX} = \frac{P_{TX} \times G_{TX}}{4 \times \pi \times D^2} \times RCS \times \frac{1}{4 \times \pi \times D^2} \times A_{eff} \quad (C.1)$$

with:

- P_{TX} : transmitter power [W]
- G_{TX} : gain of the transmit antenna
- D : distance between EUT and object [m]
- RCS : radar cross section [m²]
- P_{RX} : power received back from the object by the EUT [W]
- A_{eff} : effective area of the receiving antenna [m²], see equation (C.2):

$$A_{eff} = \frac{G_{RX} \times \lambda^2}{4 \times \pi} \quad (C.2)$$

with:

- G_{RX} : gain of the receiving antenna
- λ : wavelength of the radio signal [m]

and provided that the transmitter and the receiver are co-located, and the same antenna is used for transmitting and receiving ($G_{TX} = G_{RX} = G$):

$$P_{RX} = \frac{P_{TX} \times G_{TX}}{4 \times \pi \times D^2} \times RCS \times \frac{1}{4 \times \pi \times D^2} \times \frac{G_{RX} \times \lambda^2}{4 \times \pi} \quad (C.3)$$

$$P_{RX} = \frac{P_{TX} \times G^2 \times \lambda^2}{(4 \times \pi)^3 \times D^4} \times RCS \quad (C.4)$$

A radio determination device (EUT) is only able to detect a signal reflected from an object (target) if the signal is above the sensitivity level of the EUT receiver. The level "above" the sensitivity is necessary to guarantee an object detection (detection probability):

$$P_{RX} \geq \text{Sensitivity of RX} \quad (\text{C.5})$$

For the RBS requirement (sensitivity) for radiodetermination in a harmonised standard it is therefore sufficient to specify:

- the object (kind of) or a representative RCS (which could be realized by e.g. triple mirror, see ETSI TS 103 789 [i.11], table A.1);
- a minimum distance of the object to the EUT; and
- a technical wanted performance criteria: e.g. detection probability.

The antenna gain and transmit power is given by the TX-requirements in the harmonised standard (part of the radio regulation).

With these set of specified requirements/parameters in the related standard each EUT has to fulfil a clear minimum level of sensitivity to guarantee a level of detection.

Annex D (informative): Object and Radar Cross Section

D.1 Wanted objects

In radar measurements power is transmitted towards an object and the reflected power is received. The received power depends - among others - on the radar cross section σ of the object:

$$P_{Rx} \propto \sigma \quad (D.1)$$

The radar cross section σ in turn depends on several parameters:

- Frequency of radar signal.
- Object material.
- Object shape.
- Object size.
- Object motion.
- More information on Radar Cross Section in relation to object are provided in ETSI TS 103 789 [i.11], clause 5

D.2 Direct Object Reflectors

By using well conducting metal as material and by limiting the complexity of the geometric shape and by avoiding motion, reflectors can be realized for which the reflection behavior is simple enough to be analytically computed.

- More information on Direct Object Reflectors see ETSI TS 103 789 [i.11], clauses 4.2 and A.1.

By adding motion to a direct object reflector, the occurring Doppler effect causes the reflected power to be shifted in frequency ($f_c + f_D$):

$$f_D = \frac{2 \times v_r}{\lambda} \quad (D.2)$$

Motion towards (v_r) the radar sensor gives a positive frequency shift while motion away from the radar sensor gives a negative frequency shift.

An example of such a reflector is a rotating fan.

D.3 Delay Line Object Reflectors

To realize an object reflector at a distance larger than the size of a test lab, a wound-up waveguide can be used as shown in figure D.1.

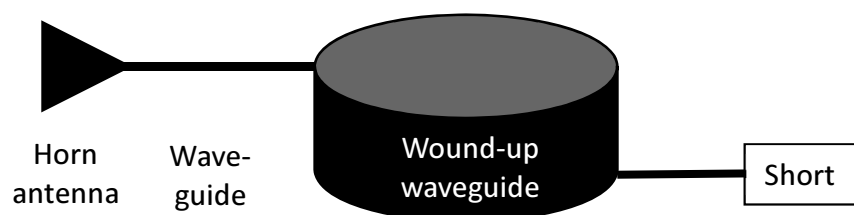

Figure D.1: Schematic diagram of a delay line object reflector with wound-up waveguide

The effective length is equal to the waveguide length multiplied by the ratio of speed of light in free space and phase velocity in the waveguide.

D.4 Electronic Object Reflectors

More information on electronic object reflectors also named target simulators, see ETSI TS 103 788 [i.10].

D.5 Test Setup with Conventional RCS within Chamber

To measure the performance of a radar sensor in a reproducible environment with reduced noise anechoic chambers are used, see figure D.2. The radar sensor is mounted inside the chamber which causes radar echo signals to be absorbed by specific absorption material in form of pyramids.

Placing a corner reflector with great RCS at a certain distance, the radar measures the corresponding object at the certain range. Due to the physical size limits of anechoic chambers the radar can only measure the maximum distance at which the corner reflector can be placed at.

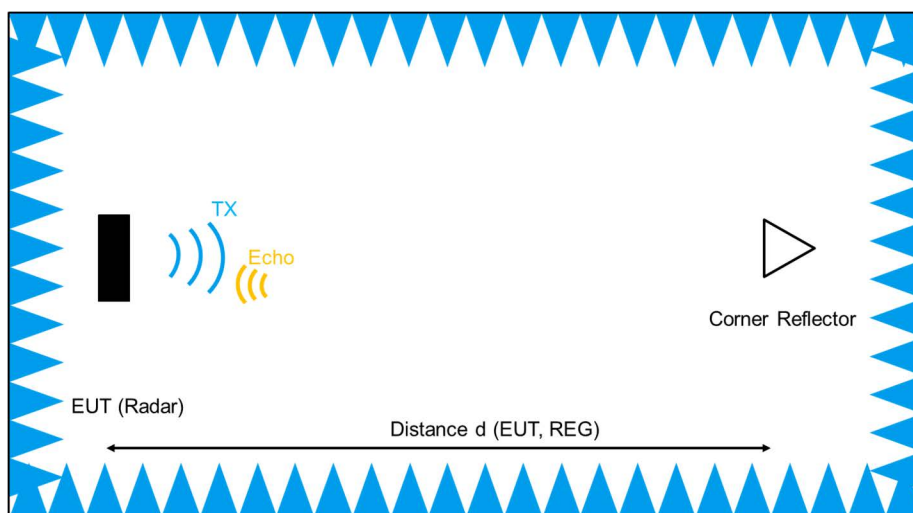

Figure D.2: Radar corner reflector inside an anechoic chamber

In addition, near-field and far-field considerations have to be taken into account, see figure D.3. The Fresnel region, is the region up to the far field in which a quadratic phase approximation can be used in the vector potential integral. Far field: radial dependence of electric and magnetic fields varies approximately as $\frac{e^{-i\omega D}}{d}$ (dependency on distance D only).

The zones depend on the wavelength and antenna size of the radar under test. Close to the radar up to $\frac{\lambda}{2\pi}$ the reactive zone is present, which leads to the near-field zone and then far-field starting approximately from $\frac{2A^2}{\lambda}$. This clarifies that a radar operating at 77 GHz with 5 cm antenna aperture A would require 1,3 m distance to be in far field according to theory.

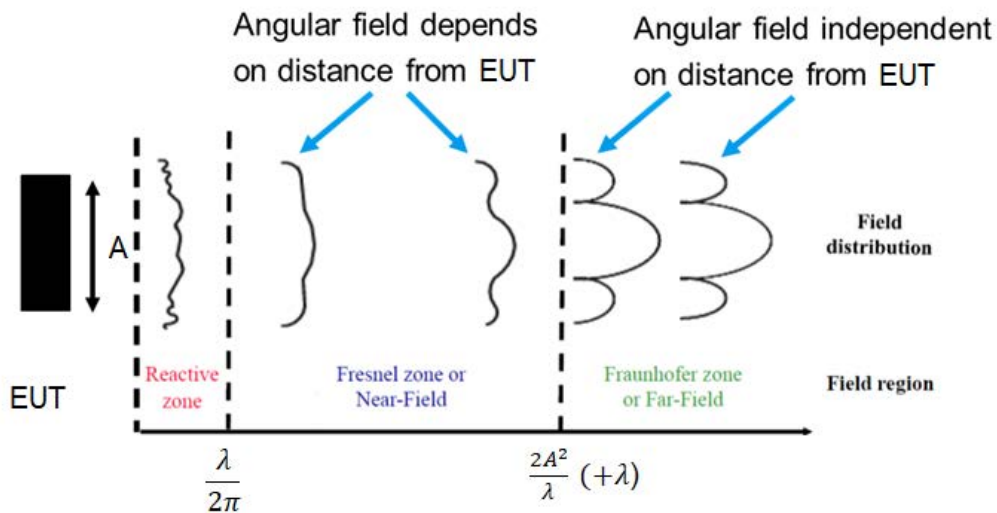

Figure D.3: Near-field and far-field considerations

Figure D.4 shows an antenna array of a base station at 2,7 GHz and that theory is only an approximation. Electromagnetic wave properties do not change at sharp borders at certain distances, but this is rather a constantly adapting process.

However, one can see that due to high frequency and small aperture size, automotive radar can be tested at comparably small ranges, e.g. 1,3 m.

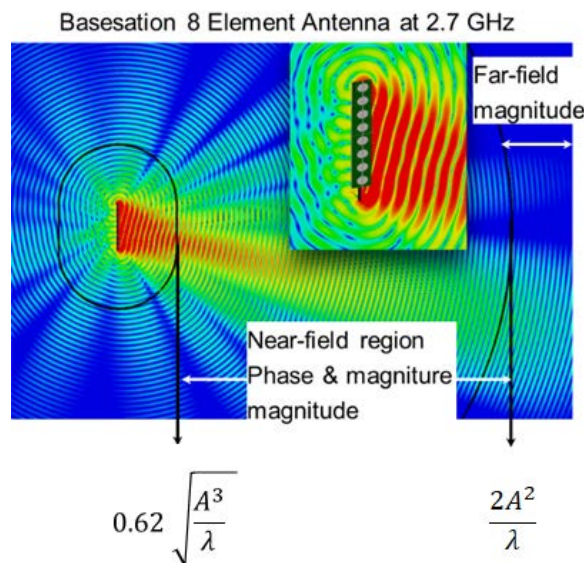

Figure D.4: Example of an 8 element antenna at 2,7 GHz, near-field and far-field effects

D.6 Test Setup with Radar Object Generator

More information on electronic object reflectors also named target simulators, see ETSI TS 103 788 [i.10]

Annex E (normative): Assessment procedure to find direction of the highest sensitivity

E.1 General

For EUT with different TX and RX antenna pattern the test shall be performed in the direction of the highest RX sensitivity (or in any direction with sufficient sensitivity).

Therefore the arrangement between transmit test antenna/target shall be in the direction of the highest sensitivity (highest gain of the RX antenna).

For such EUT with different TX/RX pattern the measurement procedures need to be adjusted.

Therefore, for EUT:

- Under clause 5.4.3.3 "Radiated Measurements for Radio Communication Devices with Power Limit" and clause 5.4.3.4 "Radiated measurements for radio communication devices with distance limit", see clause E.2.
- Under clause 5.4.3.5 "Radiated Measurements for Radiodetermination Applications with Distance Limit", see clause E.3.

E.2 Assessment for communication devices

For the first arrangement between the EUT and transmit test antenna the direction of the highest TX emission shall be used for the arrangement. The direction with the highest TX emission shall be pointed to the main beam direction of the transmit test antenna, see clause 5.4.3.3.3.2; figure 8 for communication devices with power limit or clause 5.4.3.3.4.2; figure 11 for communication devices with a distance limit.

The transmit test antenna according to ETSI EN 303 883-1 [1], clause B.2.2.5 shall be placed to the test site and pointing with its main beam direction to the EUT and at the same height as the EUT as well.

After arrangement of EUT and transmit test antenna start with the assessment steps to find the direction with the highest (minimum required) sensitivity.

Assessment steps:

- Step 1: after arrangement follow the measurement and assessment procedure in:
 - clause 5.4.3.3.3.2 (measurement) and clause 5.4.3.3.4 (assessment) in for communication devices with power limit;
 - clause 5.4.3.3.4.2 (measurement) and clause 5.4.3.4.4 (assessment) for communication devices with a distance limit.
- Step 2: assess result out of step 1, if:
 - if the assessment of the of the wanted technical performance criterium is passed the EUT RX sensitivity is sufficient (minimum specified RBS limit in related standard is reached);
 - if the wanted technical performance criterium is not passed, go to step 3.
- Step 3: turn the EUT horizontal (right from top view) by 10 deg (if not otherwise specified in the related standard) and go back to step 1:
 - If after three steps no positive assessment go back to the first arrangement and turn horizontal by 10deg (left from the top view) and restart with step 1.

- If after now six steps (three right/three left) in the horizontal directions go back to the first arrangement and turn now vertical by 10 deg upwards.
 - If after three steps upwards in the vertical direction no positive assessment go back to the first arrangement and turn now vertical by 10 deg downward.
 - If after this steps no positive assessment all other points around the sphere need to be assessed (vertical and horizontal steps) to find the most sensitive direction.
- Step 4: If no direction was found the EUT will not pass the wanted technical criteria and the sensitivity limit as specified in the related standard.

E.3 Assessment for radiodetermination devices

For the first arrangement between the EUT and test target the direction of the highest TX emission shall be used for the arrangement. The direction with the highest TX emission shall be pointed to main direction of the test target (direction of the specified RCS (see related standard and TS 103 789 [i.11], Annex A), see clause 5.4.3.5.3.2; figure 12 for radio determination devices with a distance limit.

The test target according as specified in the related standard shall be placed to the test site and pointing with the specified orientation (RCS) to the EUT and at the same height as the EUT as well.

After arrangement of EUT and test target start with the assessment steps to find the direction with the highest (minimum required) sensitivity.

Assessment steps:

- Step 1: after arrangement follow the measurement and assessment procedure in:
 - clause 5.4.3.5.3.2 (measurement) and clause 5.4.3.5.4 (assessment) for communication devices with a distance limit.
- Step 2: assess result out of step 1, if:
 - if the assessment of the of the wanted technical performance criterium is passed the EUT RX sensitivity is sufficient (minimum specified RBS limit in related standard is reached);
 - if the wanted technical performance criterium is not passed, go to step 3.
- Step 3: turn the EUT horizontal (right from top view) by 10 deg (if not otherwise specified in the related standard) and go back to step 1:
 - If after three steps no positive assessment go back to the first arrangement and turn horizontal by 10deg (left from the top view) and restart with step 1.
 - If after now six steps (three right/three left) in the horizontal directions go back to the first arrangement and turn now vertical by 10 deg upwards.
 - If after three steps upwards in the vertical direction no positive assessment go back to the first arrangement and turn now vertical by 10 deg downward.
 - If after this steps no positive assessment all other points around the sphere need to be assessed (vertical and horizontal steps) to find the most sensitive direction.
- Step 4: If no direction was found the EUT will not pass the wanted technical criteria and the sensitivity limit as specified in the related standard.

Annex F (informative): Parameter and Specification in related Standards

This clause provides a quick overview on parameter or other conformance test relevant points (e.g. test set-up, test environment) the related standard need to specify for RX measurements. A kind of checklist is provided in table F.1 (general issues)

Table F.1. checklist on issues the related standard need to consider

General issues for all RX requirements		
Issue	The related standard (rS) need to consider and specify	See clause
Test site	For each requirement one test site. See note.	ETSI EN 303 883-1 [1] for the environment (OATS, SAC and FAR), see clause 5.1
Kind of conformance test (radiated or conducted)	if the RX requirement will be tested radiated or conducted. And if there are different option necessary (depending on e.g. EUT categories) the rS need to specify the circumstances under which situation which test site apply. To avoid errors in testing results for the RBS and RBR requirement the rS need to specify the testing based on the same measurement procedure concept.	See related clause 5 For same test, see table 8 in clause 5.5.3.1
Environmental conditions	Not applicable Justification: considering ETSI EN 303 883-1 [1] and ETSI TS 103 941 [i.12] currently there is no justified RX-parameter assessment of the environmental profile. Based on the difficulties (see ETSI TS 103 941 RX testing over the complete environmental profile seems to be very difficult (space inside the chamber; all additional relevant parts for testing (companion device, interfering signal source, target) has to be outside the temperature chamber and within the "main" focus of the EUT.	Clause 5.1 and ETSI EN 303 883-1 [1] and ETSI TS 103 941 [i.12].
EUT categories and wanted technical performance criteria	The same EUT categories as for the TX-testing need to be considered. In addition, the rS need to specify the related test set-up to reflect the intended use (e.g. target, etc.). This information (kind of) and to prepare the target need to be specified in the rS (e.g. specific Annexes).	ETSI EN 303 883-1 [1] And clause 5.3
	For radar like use-cases the ETSI TS 103 788 [i.10] and ETSI TS 103 789 [i.11] need to be considered to specify the necessary target.	See ETSI TS 103 788 [i.10] ETSI TS 103 789 [i.11]
RX requirement justification	He related rS need to provide the information on the RX-requirement justification (specific Annex in rS).	Annex C
General issues for measurement/requirement		
RBS testing	The rS need to specify the related conformance test procedure based on the intended – use and the wanted technical performance.	5.4.3.1; table 7
	The rS need to specify the related wanted technical performance criteria based on the intended.	5.3.2 (general) 5.3.3.1 for communication /tracking devices 5.3.3.2 determination devices 5.3.3.3 material contact-based devices
RBR testing	The rS need to specify the related conformance test procedure based on the RBS test.	5.5.3.1; table 8
	The rS need to specify the wanted technical performance criteria based on the intended use (EUT category) and the related RBS test.	5.4.1
	The rS need to specify the Interfering signals based on the EUT category, intended use, etc. Therefore, it could be necessary to provide a list of relevant interferers with all essential parameter.	Annex A

General issues for all RX requirements		
Issue	The related standard (rS) need to consider and specify	See clause
RX spurious emission	The rS need to specify if for the EUT (category) and the intended use the RX – spurious emission test is applicable. If applicable the rS need to specify the test site and the operational mode of the EUT for which the testing in applicable.	5.2
NOTE: This could be different for EUT categories (intended use).		

Annex G (informative): Change history

Version	Information about changes
1.1.1	First initial version of ETSI EN 303 883-2 to provide a common EN to provide receiver conformance test set-ups for device under the interferer signal handling concept
2.1.1	<p>The main changes compared to the previous version are:</p> <ul style="list-style-type: none"> • revise the text and adding reference to ETSI documents with more details to make the receiver testing more precise <ul style="list-style-type: none"> – ETSI TS 103 788 (V1.1.1) (2022-09): "Short Range Devices (SRD) and Ultra Wide Band (UWB); Measurement techniques and specification for RX conformance tests with target simulator" – ETSI TS 103 789 (V1.1.1) (2023-05): "Short Range Devices (SRD) and Ultra Wide Band (UWB); Radar related parameters and physical test setup for object detection, identification and RCS measurement" • Adding a guidance to find the direction of the highest RX sensitivity level (Annex E) • Update Annex A to reflect ECC discussions on receiver resilience

History

Document history		
V1.1.1	September 2016	Publication as ETSI EN 303 883
V1.2.1	February 2021	Publication
V2.1.0	January 2024	EN Approval Procedure AP 20240411: 2024-01-12 to 2024-04-11