

ETSI EN 303 758 V1.1.1 (2021-07)



**TETRA radio equipment using non-constant envelope
modulation operating in a channel bandwidth
of 25 kHz, 50 kHz, 100 kHz or 150 kHz;
Harmonised Standard for access to radio spectrum**

ReferenceDEN/ERM-TGDMMR-381

Keywordsdata, mobile, PMR, radio, repeater, TETRA, voice

ETSI650 Route des Lucioles
F-06921 Sophia Antipolis Cedex - FRANCE

Tel.: +33 4 92 94 42 00 Fax: +33 4 93 65 47 16

Siret N° 348 623 562 00017 - APE 7112B
Association à but non lucratif enregistrée à la
Sous-Préfecture de Grasse (06) N° w061004871

Important notice

The present document can be downloaded from:

<http://www.etsi.org/standards-search>

The present document may be made available in electronic versions and/or in print. The content of any electronic and/or print versions of the present document shall not be modified without the prior written authorization of ETSI. In case of any existing or perceived difference in contents between such versions and/or in print, the prevailing version of an ETSI deliverable is the one made publicly available in PDF format at www.etsi.org/deliver.

Users of the present document should be aware that the document may be subject to revision or change of status.

Information on the current status of this and other ETSI documents is available at

<https://portal.etsi.org/TB/ETSIDeliverableStatus.aspx>

If you find errors in the present document, please send your comment to one of the following services:

<https://portal.etsi.org/People/CommitteeSupportStaff.aspx>

Notice of disclaimer & limitation of liability

The information provided in the present deliverable is directed solely to professionals who have the appropriate degree of experience to understand and interpret its content in accordance with generally accepted engineering or other professional standard and applicable regulations.

No recommendation as to products and services or vendors is made or should be implied.

In no event shall ETSI be held liable for loss of profits or any other incidental or consequential damages.

Any software contained in this deliverable is provided "AS IS" with no warranties, express or implied, including but not limited to, the warranties of merchantability, fitness for a particular purpose and non-infringement of intellectual property rights and ETSI shall not be held liable in any event for any damages whatsoever (including, without limitation, damages for loss of profits, business interruption, loss of information, or any other pecuniary loss) arising out of or related to the use of or inability to use the software.

Copyright Notification

No part may be reproduced or utilized in any form or by any means, electronic or mechanical, including photocopying and microfilm except as authorized by written permission of ETSI.

The content of the PDF version shall not be modified without the written authorization of ETSI.

The copyright and the foregoing restriction extend to reproduction in all media.

© ETSI 2021.
All rights reserved.

Contents

| | |
|--|----|
| Intellectual Property Rights | 7 |
| Foreword..... | 7 |
| Modal verbs terminology..... | 8 |
| 1 Scope | 9 |
| 2 References | 9 |
| 2.1 Normative references | 9 |
| 2.2 Informative references..... | 10 |
| 3 Definition of terms, symbols and abbreviations..... | 11 |
| 3.1 Terms..... | 11 |
| 3.2 Symbols..... | 12 |
| 3.3 Abbreviations | 12 |
| 4 General | 13 |
| 4.1 Testing..... | 13 |
| 4.1.1 Choice of model for testing | 13 |
| 4.1.1.1 General..... | 13 |
| 4.1.1.2 Auxiliary test equipment..... | 13 |
| 4.1.2 Presentation of equipment for testing purposes | 14 |
| 4.2 Mechanical and electrical design..... | 14 |
| 4.2.1 Transmitter shut-off facility..... | 14 |
| 4.3 Measuring continuous mode equipment..... | 14 |
| 4.4 Measuring discontinuous mode equipment | 14 |
| 4.5 Equipment supporting more than one channel bandwidth..... | 14 |
| 4.6 Environmental profile..... | 15 |
| 5 Test conditions, power sources and ambient temperatures | 15 |
| 5.1 Normal and extreme test conditions | 15 |
| 5.2 Test power source..... | 15 |
| 5.3 Normal test conditions..... | 15 |
| 5.3.1 Normal temperature and humidity | 15 |
| 5.3.2 Normal test power source | 15 |
| 5.3.2.1 Mains voltage..... | 15 |
| 5.3.2.2 Regulated lead-acid battery power sources used on vehicles..... | 16 |
| 5.3.2.3 Other power sources..... | 16 |
| 5.4 Extreme test conditions | 16 |
| 5.4.1 Extreme temperatures | 16 |
| 5.4.2 Extreme test source voltages..... | 16 |
| 5.4.2.1 Mains voltage..... | 16 |
| 5.4.2.2 Regulated lead-acid battery power sources used on vehicles..... | 16 |
| 5.4.2.3 Power sources using other types of batteries..... | 16 |
| 5.4.2.4 Other power sources..... | 16 |
| 5.5 Procedure for tests at extreme temperatures..... | 17 |
| 5.5.1 Thermal balance..... | 17 |
| 5.5.2 Procedure for equipment designed for continuous transmission..... | 17 |
| 5.5.3 Procedure for equipment designed for intermittent transmission | 17 |
| 5.5.4 Testing of equipment that does not have an external 50 Ω RF connector (integral antenna equipment)..... | 17 |
| 6 General conditions of measurement | 18 |
| 6.1 Arrangements for test signals applied to the receiver input..... | 18 |
| 6.2 Test load (artificial antenna)..... | 18 |
| 6.3 Test signals (wanted and unwanted signals)..... | 18 |
| 6.3.1 General..... | 18 |
| 6.3.2 Test signal T1 (TETRA wanted signal, phase modulation)..... | 18 |
| 6.3.2.1 Test signal framing..... | 18 |
| 6.3.2.2 MS testing | 18 |

| | | |
|-----------|---|----|
| 6.3.2.3 | BS testing | 19 |
| 6.3.3 | Test signal T2 (TETRA interferer) | 20 |
| 6.3.4 | Test signal T3 (unmodulated interferer) | 20 |
| 6.3.5 | Test signal T4 (TETRA wanted signal, QAM) | 20 |
| 6.3.5.1 | Test signal structure | 20 |
| 6.3.5.2 | MS testing | 20 |
| 6.3.5.2.1 | Test signal usage | 20 |
| 6.3.5.2.2 | Use of synchronization burst in frame 18 when testing CA MSs | 22 |
| 6.3.5.2.3 | Use of frequency correction burst in frame 18 when testing DA MSs | 24 |
| 6.3.5.3 | BS testing | 26 |
| 6.4 | Transceiver data interface | 26 |
| 6.5 | Duplex equipment | 26 |
| 6.6 | Measurement filter definition | 27 |
| 6.7 | TMO Repeaters | 27 |
| 7 | Technical characteristics of the transmitter | 27 |
| 7.1 | Transmitter output power (conducted) | 27 |
| 7.1.1 | Definitions | 27 |
| 7.1.2 | Method of measurement | 28 |
| 7.1.3 | Limits | 28 |
| 7.2 | Adjacent and alternate channel power | 29 |
| 7.2.1 | Definition | 29 |
| 7.2.2 | Method of measurement | 30 |
| 7.2.3 | Limits | 31 |
| 7.2.3.1 | Limits for TMO Repeaters | 31 |
| 7.2.3.2 | Limits for BS and MS equipment | 31 |
| 7.2.3.2.1 | Limit values for phase modulation | 31 |
| 7.2.3.2.2 | Limit values for QAM | 32 |
| 7.3 | Unwanted emissions in the spurious domain | 33 |
| 7.3.1 | Definition | 33 |
| 7.3.2 | Method of measuring the power level | 33 |
| 7.3.2.1 | Measurement options | 33 |
| 7.3.2.2 | Method of measuring conducted spurious emissions | 34 |
| 7.3.2.3 | Method of measuring radiated spurious emissions | 34 |
| 7.3.2.4 | Method of measuring the effective radiated power | 35 |
| 7.3.2.5 | Method of measuring wideband noise | 35 |
| 7.3.3 | Limits | 36 |
| 7.3.3.1 | Spurious emissions power | 36 |
| 7.3.3.2 | Wideband noise power | 37 |
| 7.3.3.2.1 | Limit values for MS and BS for phase modulation | 37 |
| 7.3.3.2.2 | Limit values for MS and BS for QAM | 38 |
| 7.3.3.2.3 | Limit values for TMO repeater equipment | 39 |
| 7.4 | Intermodulation attenuation | 40 |
| 7.4.1 | Applicability | 40 |
| 7.4.2 | Definition | 40 |
| 7.4.3 | Method of measurement | 40 |
| 7.4.3.1 | Measurement for TMO repeater equipment | 40 |
| 7.4.3.2 | Measurement for BS | 41 |
| 7.4.4 | Limits | 41 |
| 7.4.4.1 | Limits for TMO repeater equipment | 41 |
| 7.4.4.2 | Limits for BS equipment | 42 |
| 7.5 | Adjacent channel transient power measurements | 42 |
| 7.5.1 | Definition | 42 |
| 7.5.2 | Method of Measurement | 42 |
| 7.5.3 | Limits | 43 |
| 7.6 | Frequency error | 43 |
| 7.6.1 | Definition | 43 |
| 7.6.2 | Method of measurement | 43 |
| 7.6.3 | Limits | 44 |
| 7.7 | Out of band gain for TMO repeater equipment | 44 |
| 7.7.1 | Applicability | 44 |
| 7.7.2 | Definition | 44 |

| | | |
|-------------------------------|---|-----------|
| 7.7.3 | Method of measurement | 44 |
| 7.7.4 | Limits..... | 45 |
| 7.8 | Modulation accuracy | 45 |
| 7.8.1 | Applicability | 45 |
| 7.8.2 | Definition..... | 45 |
| 7.8.3 | Method of measurement | 45 |
| 7.8.4 | Limits..... | 46 |
| 8 | Technical characteristics of the receiver | 46 |
| 8.1 | Applicability..... | 46 |
| 8.2 | Receiver sensitivity | 46 |
| 8.2.1 | General..... | 46 |
| 8.2.2 | Definition..... | 46 |
| 8.2.3 | Method of measurement | 47 |
| 8.2.4 | Limits..... | 47 |
| 8.2.4.1 | Limit values for phase modulation..... | 47 |
| 8.2.4.2 | Limit values for QAM..... | 48 |
| 8.3 | Blocking or desensitization | 48 |
| 8.3.1 | Definition..... | 48 |
| 8.3.2 | Method of measurement | 48 |
| 8.3.3 | Limits..... | 49 |
| 8.4 | Adjacent channel selectivity..... | 49 |
| 8.4.1 | Definition..... | 49 |
| 8.4.2 | Method of measurement | 49 |
| 8.4.3 | Limits..... | 50 |
| 8.5 | Spurious radiations..... | 51 |
| 8.5.1 | Definition..... | 51 |
| 8.5.2 | Methods of measurement..... | 51 |
| 8.5.2.1 | Method of measuring the power level in a specified load..... | 51 |
| 8.5.2.2 | Method of measuring the effective radiated power..... | 51 |
| 8.5.3 | Limits..... | 52 |
| 8.6 | Co-channel rejection..... | 53 |
| 8.6.1 | Definition..... | 53 |
| 8.6.2 | Method of measurement | 53 |
| 8.6.3 | Limits..... | 54 |
| 8.6.3.1 | Limit values for phase modulation..... | 54 |
| 8.6.3.2 | Limit values for QAM..... | 54 |
| 8.7 | Intermodulation response rejection | 54 |
| 8.7.1 | Definition..... | 54 |
| 8.7.2 | Method of measurement | 55 |
| 8.7.3 | Limit | 55 |
| 8.8 | Spurious response rejection..... | 56 |
| 8.8.1 | Definition..... | 56 |
| 8.8.2 | Method of measurement | 56 |
| 8.8.3 | Limits..... | 56 |
| Annex A (informative): | Relationship between the present document and the essential requirements of Directive 2014/53/EU | 57 |
| Annex B (normative): | Radiated measurement..... | 59 |
| B.1 | Test sites and general arrangements for measurements involving the use of radiated fields | 59 |
| B.1.1 | General | 59 |
| B.1.2 | Anechoic chamber..... | 59 |
| B.1.3 | Anechoic chamber with a conductive ground plane..... | 60 |
| B.1.4 | Open Area Test Site (OATS) | 61 |
| B.1.5 | Test antenna..... | 62 |
| B.1.6 | Substitution antenna | 62 |
| B.1.7 | Measuring antenna | 63 |
| B.2 | Guidance on the use of radiation test sites | 63 |
| B.2.1 | General | 63 |
| B.2.2 | Verification of the test site | 63 |

| | | |
|-------------------------------|--|-----------|
| B.2.3 | Preparation of the EUT..... | 63 |
| B.2.4 | Power supplies to the EUT..... | 63 |
| B.2.5 | Range length..... | 63 |
| B.2.6 | Site preparation | 64 |
| B.3 | Coupling of signals..... | 65 |
| B.3.1 | General | 65 |
| B.3.2 | Data signals | 65 |
| Annex C (normative): | Spectrum analyser specification | 66 |
| Annex D (normative): | TETRA receiver testing..... | 67 |
| D.1 | Test signal T1/T4, content of BSCH, BSCH-Q/T, BNCH/T and BNCH-Q/T..... | 67 |
| D.2 | Frequencies of spurious response..... | 72 |
| Annex E (informative): | Example arrangement for transmitter intermodulation measurement.... | 74 |
| Annex F (informative): | Maximum measurement uncertainty..... | 75 |
| Annex G (informative): | Selection of technical parameters to meet the essential requirements of Directive 2014/53/EU..... | 76 |
| Annex H (informative): | Change History | 77 |
| History | | 78 |

Intellectual Property Rights

Essential patents

IPRs essential or potentially essential to normative deliverables may have been declared to ETSI. The declarations pertaining to these essential IPRs, if any, are publicly available for **ETSI members and non-members**, and can be found in ETSI SR 000 314: "*Intellectual Property Rights (IPRs); Essential, or potentially Essential, IPRs notified to ETSI in respect of ETSI standards*", which is available from the ETSI Secretariat. Latest updates are available on the ETSI Web server (<https://ipr.etsi.org/>).

Pursuant to the ETSI Directives including the ETSI IPR Policy, no investigation regarding the essentiality of IPRs, including IPR searches, has been carried out by ETSI. No guarantee can be given as to the existence of other IPRs not referenced in ETSI SR 000 314 (or the updates on the ETSI Web server) which are, or may be, or may become, essential to the present document.

Trademarks

The present document may include trademarks and/or tradenames which are asserted and/or registered by their owners. ETSI claims no ownership of these except for any which are indicated as being the property of ETSI, and conveys no right to use or reproduce any trademark and/or tradename. Mention of those trademarks in the present document does not constitute an endorsement by ETSI of products, services or organizations associated with those trademarks.

DECT™, **PLUGTESTS™**, **UMTS™** and the ETSI logo are trademarks of ETSI registered for the benefit of its Members. **3GPP™** and **LTE™** are trademarks of ETSI registered for the benefit of its Members and of the 3GPP Organizational Partners. **oneM2M™** logo is a trademark of ETSI registered for the benefit of its Members and of the oneM2M Partners. **GSM®** and the GSM logo are trademarks registered and owned by the GSM Association.

Foreword

This Harmonised European Standard (EN) has been produced by ETSI Technical Committee Electromagnetic compatibility and Radio spectrum Matters (ERM).

The present document has been prepared under the Commission's standardisation request C(2015) 5376 final [i.6] to provide one voluntary means of conforming to the essential requirements of Directive 2014/53/EU on the harmonisation of the laws of the Member States relating to the making available on the market of radio equipment and repealing Directive 1999/5/EC [i.2].

Once the present document is cited in the Official Journal of the European Union under that Directive, compliance with the normative clauses of the present document given in table A.1 confers, within the limits of the scope of the present document, a presumption of conformity with the corresponding essential requirements of that Directive and associated EFTA regulations.

| National transposition dates | |
|--|-------------------|
| Date of adoption of this EN: | 30 June 2021 |
| Date of latest announcement of this EN (doa): | 30 September 2021 |
| Date of latest publication of new National Standard or endorsement of this EN (dop/e): | 31 March 2022 |
| Date of withdrawal of any conflicting National Standard (dow): | 31 March 2023 |

Modal verbs terminology

In the present document "**shall**", "**shall not**", "**should**", "**should not**", "**may**", "**need not**", "**will**", "**will not**", "**can**" and "**cannot**" are to be interpreted as described in clause 3.2 of the [ETSI Drafting Rules](#) (Verbal forms for the expression of provisions).

"**must**" and "**must not**" are **NOT** allowed in ETSI deliverables except when used in direct citation.

1 Scope

The present document specifies the technical requirements and methods of measurements for TETRA radio transmitters and receivers used in stations and technical requirements and methods of measurements for TMO repeater in the Private Mobile Radio (PMR) service.

It applies to use in the land mobile service, operating on radio frequencies between 137 MHz and 1 GHz, with channel separations of 25 kHz, 50 kHz, 100 kHz and 150 kHz.

Table 1: Radiocommunications service frequency bands

| | Radiocommunications service frequency bands |
|----------|--|
| Transmit | 137 MHz to 1 000 MHz |
| Receive | 137 MHz to 1 000 MHz |

It applies to equipment for continuous and/or discontinuous transmission of data and/or digital speech.

The equipment (base station and mobile station) comprises a transmitter and associated encoder and modulator and/or a receiver and associated demodulator and decoder.

The types of equipment covered by the present document are as follows:

- base station (equipment fitted with an antenna connector, intended for use in a fixed location);
- mobile station (equipment fitted with an antenna connector, normally used in a vehicle or as a transportable);
- TMO Repeater; and
- those hand portable stations:
 - a) fitted with an antenna connector; or
 - b) without an external antenna connector (integral antenna equipment), but fitted with a permanent internal or a temporary internal 50 Ω Radio Frequency (RF) connector which allows access to the transmitter output and the receiver input.

Hand portable equipment without an external or internal RF connector and without the possibility of having a temporary internal 50 Ω RF connector is not covered by the present document.

NOTE: The relationship between the present document and essential requirements of article 3.2 of Directive 2014/53/EU [i.2] is given in annex A.

2 References

2.1 Normative references

References are either specific (identified by date of publication and/or edition number or version number) or non-specific. For specific references, only the cited version applies. For non-specific references, the latest version of the referenced document (including any amendments) applies.

Referenced documents which are not found to be publicly available in the expected location might be found at <https://docbox.etsi.org/Reference>.

NOTE: While any hyperlinks included in this clause were valid at the time of publication, ETSI cannot guarantee their long term validity.

The following referenced documents are necessary for the application of the present document.

- [1] Recommendation ITU-T O.153 (10-1992): "Basic parameters for the measurement of error performance at bit rates below the primary rate".

- [2] IEEE/ANSI C63.5 (2017): "American National Standard for Electromagnetic Compatibility -- Radiated Emission Measurements in Electromagnetic Interference (EMI) Control -- Calibration and Qualification of Antennas (9 kHz to 40 GHz)".
- [3] ETSI EN 300 392-2 (V3.8.1) (08-2016): "Terrestrial Trunked Radio (TETRA); Voice plus Data (V+D); Part 2: Air Interface (AI)".

2.2 Informative references

References are either specific (identified by date of publication and/or edition number or version number) or non-specific. For specific references, only the cited version applies. For non-specific references, the latest version of the referenced document (including any amendments) applies.

NOTE: While any hyperlinks included in this clause were valid at the time of publication, ETSI cannot guarantee their long term validity.

The following referenced documents are not necessary for the application of the present document but they assist the user with regard to a particular subject area.

- [i.1] CEPT/ERC/REC 74-01 (2019): "Unwanted Emissions in the Spurious domain".
- [i.2] Directive 2014/53/EU of the European Parliament and of the Council of 16 April 2014 on the harmonisation of the laws of the Member States relating to the making available on the market of radio equipment and repealing Directive 1999/5/EC.

NOTE: Article 3.2 and article 10.8.

- [i.3] ETSI TS 101 789-1 (V1.1.2): "Terrestrial Trunked Radio (TETRA); TMO Repeaters; Part 1: Requirements, test methods and limits".
- [i.4] ETSI EN 300 394-1 (V3.3.1) (04-2015): "Terrestrial Trunked Radio (TETRA); Conformance testing specification; Part 1: Radio".
- [i.5] ETSI EN 303 035-1 (V1.2.1) (12-2001): "Terrestrial Trunked Radio (TETRA); Harmonized EN for TETRA equipment covering essential requirements under article 3.2 of the R&TTE Directive; Part 1: Voice plus Data (V+D)".
- [i.6] Commission Implementing Decision C(2015) 5376 final of 4.8.2015 on a standardisation request to the European Committee for Electrotechnical Standardisation and to the European Telecommunications Standards Institute as regards radio equipment in support of Directive 2014/53/EU of the European Parliament and of the Council.
- [i.7] ETSI EN 300 793 (V1.1.1) (02-1998): "Electromagnetic compatibility and Radio spectrum Matters (ERM); Land mobile service; Presentation of equipment for type testing".
- [i.8] ETSI TR 102 273 (V1.2.1) (12-2001) (all parts): "Electromagnetic compatibility and Radio spectrum Matters (ERM); Improvement on Radiated Methods of Measurement (using test site) and evaluation of the corresponding measurement uncertainties".
- [i.9] ETSI EG 203 336 (V1.2.1) (05-2020): "Guide for the selection of technical parameters for the production of Harmonised Standards covering article 3.1(b) and article 3.2 of Directive 2014/53/EU".

3 Definition of terms, symbols and abbreviations

3.1 Terms

For the purposes of the present document, the following terms apply:

base station: equipment fitted with an antenna connector, for use with an external antenna, and intended for use in a fixed location

bit: binary digit

block: smallest quantity of information that is sent over the radio channel

NOTE: A constant number of useful bits are always sent together with the corresponding redundancy bits.

broadband repeater: repeater which is designed for operation on any combination of carriers (up to a specified maximum number) within the operating band of the repeater

burst or transmission (physical): one or several packets transmitted between power on and power off of a particular transmitter

channelized repeater: repeater which is designed for operation on a specified subset of carriers within the operating band of the repeater

NOTE: The subset of the channels may be determined during the manufacture of the repeater, or may be programmable.

conducted measurements: measurements which are made using direct 50 Ω connection to the equipment under test

data transmission systems: systems which transmit and/or receive data and/or digitized voice

downlink: signal path where base station transmits and mobile or hand portable station receives

hand portable station: equipment either fitted with an antenna connector or integral antenna, or both, normally used on a stand-alone basis, to be carried on a person or held in the hand

NOTE: Test limits specified for MS within the present document apply to mobile stations and handportable stations.

integral antenna: antenna designed to be connected to the equipment without the use of a 50 Ω external connector and considered to be part of the equipment

NOTE: An integral antenna may be fitted internally or externally to the equipment.

mobile station: mobile equipment fitted with an antenna connector, for use with an external antenna, normally used in a vehicle or as a transportable station

NOTE: Test limits specified for MS within the present document apply to mobile stations and handportable stations.

radiated measurements: measurements which involve the absolute measurement of a radiated field

receive band of the equipment: maximum frequency range in accordance with the intended operation of the equipment over which the receiver can be operated without reprogramming or realignment

spurious emissions: unwanted emissions in the spurious domain

testing laboratory: laboratory that performs tests

TMO Repeater: bi-directional Radio Frequency (RF) amplifier which can amplify and transmit a received Mobile Station (MS) signal in the MS transmit band, simultaneously it can amplify and transmit a received Base Station (BS) RF signal in the BS transmit band

transmit band of the equipment: maximum frequency range in accordance with the intended operation of the equipment over which the transmitter can be operated without reprogramming or realignment

Trunked Mode Operation (TMO): mode of operation where a network is used for communication

uplink: signal path where mobile or hand portable station transmits and base station receives

3.2 Symbols

For the purposes of the present document, the following symbols apply:

| | |
|--------------|--|
| α | Filter roll-off factor |
| dB | decibel |
| dBm | dB relative to 1 mW |
| dB μ V | dB relative to 1 μ V |
| f_c | channel centre frequency |
| f_{lo} | Local Oscillator frequency |
| f_{rb} | the frequency offset corresponding to the near edge of the receive band, or 5 MHz (10 MHz for frequencies above 520 MHz), whichever is greater |
| T1, T2, etc. | names of test signals defined in clause 6.3 |
| P_A | average power |
| V_{min} | minimum extreme test Voltage |
| V_{max} | maximum extreme test Voltage |
| T_{min} | minimum extreme test Temperature |
| T_{max} | maximum extreme test Temperature |
| λ | wavelength |

3.3 Abbreviations

For the purposes of the present document, the following abbreviations apply:

| | |
|--------|--|
| AACH | Access Assignment CHannel |
| AACH-Q | Access Assignment CHannel, QAM |
| AC | Alternating Current |
| ACP | Adjacent Channel Power |
| AGC | Automatic Gain Control |
| BCC | Base station Colour Code |
| BER | Bit Error Rate |
| BLCH | Base station Linearization CHannel |
| BNCH/T | Broadcast Network CHannel, Test mode |
| BS | Base Station |
| BSCH | Broadcast Synchronization CHannel |
| BW | BandWidth |
| CA | Conventional Access |
| CA MS | Conventional Access Mobile Station |
| CEPT | European Conference of Postal and Telecommunications administrations |
| CLCH | Common Linearization CHannel |
| CW | Continuous Wave |
| DA | Direct Access |
| DA MS | Direct Access Mobile Station |
| dBc | decibels relative to the transmitter power |
| DC | Direct Current |
| DMO | Direct Mode Operation |
| DQPSK | Differential Quadrature Phase Shift Keying |
| DTX | Discontinuous Transmission |
| EC | European Community |
| EFTA | European Free Trade Association |
| EUT | Equipment Under Test |
| FCB | Frequency Correction downlink Burst |

| | |
|----------------|--|
| FER | Frame Erasure Rate |
| IF | Intermediate Frequency |
| ITU-T | International Telecommunication Union - Telecommunication standardization sector |
| MCC | Mobile Country Code |
| MNC | Mobile Network Code |
| MS | Mobile Station |
| OATS | Open Area Test Site |
| PDU | Protocol Data Unit |
| PMR | Private Mobile Radio |
| ppm | parts per million |
| PQ | Power level of QAM burst |
| PRBS | Pseudo Random Bit Sequence |
| QAM | Quadrature Amplitude Modulation |
| RDC | Radio Downlink Counter |
| RF | Radio Frequency |
| rms | root mean square |
| Rx | Receiver |
| SCH/F | Signalling CHannel Full |
| SCH/HD | Signalling CHannel, Half size Downlink |
| SCH/HU | Signalling CHannel, Half size Uplink |
| SICH-Q/D | Slot Information CHannel, QAM Downlink |
| SN-Q | Symbol Number in QAM |
| STCH | STealing CHannel |
| TCH/S | Traffic CHannel, Speech |
| TETRA | TErrestrial Trunked RAdio |
| TMO | Trunked Mode Operation |
| Tx | Transmitter |
| VSWR | Voltage Standing Wave Ratio |
| $\pi/4$ -DQPSK | $\pi/4$ -shifted Differential Quaternary Phase Shift Keying |

4 General

4.1 Testing

4.1.1 Choice of model for testing

4.1.1.1 General

One or more samples of the equipment shall be provided, as appropriate for testing. Stand-alone equipment shall be complete with any ancillary equipment needed for testing.

If an equipment has several optional features, considered not to affect the RF parameters, then the tests need only be performed on the equipment configured with the combination of features considered to be the most complex. Where practicable, equipment to be tested shall provide a 50 Ω connector for conducted RF power level measurements.

In the case of integral antenna equipment, if the equipment does not have an internal permanent 50 Ω connector then it is permissible to use a second sample of the equipment with a temporary antenna connector fitted to facilitate testing. Any such modified sample shall not be used for any radiated measurements, except as noted in clause 5.5.4.

The performance of the equipment to be tested shall be representative of the performance of the corresponding production model.

4.1.1.2 Auxiliary test equipment

All necessary test signal sources, setting up instructions and other product information shall be made available with the equipment to be tested.

4.1.2 Presentation of equipment for testing purposes

The radio tests shall be performed on one or more frequency channels selected from the lowest 5, the highest 5 and/or the middle 5 radio frequency channels of either the transmit or receive band of the equipment, whichever is appropriate, according to the test requirements of the clauses of the present document.

NOTE: Permitting a selection from a range of five channels in each case is intended to allow any interference effects at spot frequencies in the measurement arrangement to be avoided.

The frequency ranges, the range of operating conditions and power requirements as applicable, shall be in accordance with the intended use of the equipment to establish the appropriate test conditions. For BS and MS equipment information related to radio sub-system of equipment includes the transmit and receive frequency bands, first local oscillator frequency and intermediate frequencies of the receiver.

All requirements applicable to mobile stations within the present document also apply to handportable stations.

Additionally, technical documentation and operating manuals, sufficient to make the test, shall be supplied. All necessary setting up instructions and other product information shall be made available with the equipment to be tested, in accordance with article 10.8 of Directive 2014/53/EU [i.2].

For TMO Repeater Equipment the intended use of the equipment shall include:

- a) the operating band or bands of the repeater;
- b) the maximum rated output power per channel;
- c) the number of channels supported by the repeater.

Guidance on the presentation of equipment is also given in ETSI EN 300 793 [i.7].

4.2 Mechanical and electrical design

4.2.1 Transmitter shut-off facility

When a timer for an automatic shut-off facility is operative, at the moment of the time-out the transmitter shall automatically be switched off (the re-activation of the transmitter shall reset the timer).

A shut-off facility shall be inoperative for the duration of the measurements unless it has to remain operative to protect the equipment. If the shut-off facility is left operative the status of the equipment shall be indicated.

4.3 Measuring continuous mode equipment

In the case of measurements performed on equipment designed to operate only in continuous mode, requirements such as "equipment shall be set in continuous mode" shall be interpreted as "equipment shall be used in its normal transmission mode (in this case, the continuous mode)".

4.4 Measuring discontinuous mode equipment

When it is specified that the transmission shall be continuous for the duration of the measurement(s), the transmitter under test shall be set to operate in continuous mode. If this is not possible, the measurements shall be carried out in a period shorter than the duration of the transmitted burst. It may be necessary to extend the duration of the burst.

When measurements are made in discontinuous mode, the reported values can be average values. This averaging shall be made using a set of measurements, each of these measurements being made during a burst or a part of it.

4.5 Equipment supporting more than one channel bandwidth

In the case of equipment supporting more than one channel bandwidth, measurements shall be performed on each channel bandwidth implemented.

4.6 Environmental profile

The technical requirements of the present document apply under the environmental profile for operation of the equipment, which shall be in accordance with its intended use, but as a minimum, shall be that specified in the test conditions contained in the present document. The equipment shall comply with all the technical requirements of the present document at all times when operating within the boundary limits of the operational environmental profile defined by its intended use.

5 Test conditions, power sources and ambient temperatures

5.1 Normal and extreme test conditions

Testing shall be performed under normal test conditions, and also, where stated, under extreme test conditions.

The test conditions and procedures shall be as specified in clauses 5.2 to 5.5.

5.2 Test power source

During testing the power source of the equipment shall be replaced by a test power source capable of producing normal and extreme test voltages as specified in clauses 5.3.2 and 5.4.2. The internal impedance of the test power source shall be low enough for its effect on the test results to be negligible. For the purpose of tests, the voltage of the power source shall be measured at the input terminals of the equipment.

For battery operated equipment the battery shall be removed and the test power source shall be applied as close to the battery terminals as practicable.

During tests of DC powered equipment the voltage at the input terminals of the equipment shall be maintained within a tolerance of $< \pm 1$ % relative to the voltage at the beginning of each test. The value of this tolerance is critical for power measurements. Using a smaller tolerance will provide better measurement uncertainty values.

5.3 Normal test conditions

5.3.1 Normal temperature and humidity

The normal temperature and humidity conditions for tests shall be any convenient combination of temperature and humidity within the following ranges:

- temperature: +15 °C to +35 °C;
- relative humidity: 20 % to 75 %.

When it is impracticable to carry out the tests under these conditions, a note to this effect, stating the ambient temperature and relative humidity during the tests, shall be added to the test report.

5.3.2 Normal test power source

5.3.2.1 Mains voltage

The normal test voltage for equipment to be connected to the mains shall be the nominal mains voltage. For the purpose of the present document, the nominal voltage shall be the declared voltage or any of the declared voltages for which the equipment was designed.

The frequency of the test power source corresponding to the AC mains shall be between 49 Hz and 51 Hz.

5.3.2.2 Regulated lead-acid battery power sources used on vehicles

When the radio equipment is intended for operation from the usual types of regulated lead-acid battery power source used on vehicles the normal test voltage shall be 1,1 times the nominal voltage of the battery (for nominal voltages of 6 V and 12 V, these are 6,6 V and 13,2 V respectively).

5.3.2.3 Other power sources

For operation from other power sources or types of battery (primary or secondary), the normal test voltage shall be that appropriate for the intended use of the equipment.

5.4 Extreme test conditions

5.4.1 Extreme temperatures

For tests at extreme temperatures, measurements shall be made in accordance with the procedures specified in clause 5.5, at the upper and lower temperatures shall be as follows:

- the lower temperature shall be $-20\text{ }^{\circ}\text{C}$ except for BS and TMO repeater equipment where the lowest intended operational temperature of the BS/repeater shall apply if this is higher than $-20\text{ }^{\circ}\text{C}$;
- the upper temperature shall be $+55\text{ }^{\circ}\text{C}$ except for BS and TMO repeater equipment where the highest intended operational temperature of the BS/repeater shall apply if this is lower than $+55\text{ }^{\circ}\text{C}$.

In the case of base stations and TMO repeater equipment, the conditions for the intended installation of the equipment shall be used.

5.4.2 Extreme test source voltages

5.4.2.1 Mains voltage

The extreme test voltage for equipment to be connected to an AC mains source shall be the nominal mains voltage $\pm 10\%$.

5.4.2.2 Regulated lead-acid battery power sources used on vehicles

When the equipment is intended for operation from the usual types of regulated lead-acid battery power sources used on vehicles the extreme test voltages shall be 1,3 and 0,9 times the nominal voltage of the battery (for a nominal voltage of 6 V, these are 7,8 V and 5,4 V respectively and for a nominal voltage of 12 V, these are 15,6 V and 10,8 V respectively).

5.4.2.3 Power sources using other types of batteries

The lower extreme test voltages for equipment with power sources using batteries shall be as follows:

- for the nickel metal-hydride, leclanché or lithium type: 0,85 times the nominal battery voltage;
- for the mercury or nickel-cadmium type: 0,9 times the nominal battery voltage.

No upper extreme test voltages apply.

In the case where no upper extreme test voltage is applicable, the corresponding four extreme test conditions are:

- V_{\min}/T_{\min} , V_{\min}/T_{\max} ;
- $(V_{\max} = \text{nominal})/T_{\min}$, $(V_{\max} = \text{nominal})/T_{\max}$.

5.4.2.4 Other power sources

For equipment using other power sources, or capable of being operated from a variety of power sources, the extreme test voltages shall be those in accordance with the intended use of the equipment.

5.5 Procedure for tests at extreme temperatures

5.5.1 Thermal balance

Before measurements are made the equipment shall have reached thermal balance in the test chamber. The equipment shall be switched off during the temperature stabilizing period.

In the case of equipment containing temperature stabilization circuits designed to operate continuously, the temperature stabilization circuits may be switched on for 15 minutes after thermal balance has been obtained, and the equipment shall then meet the specified requirements. For such equipment the power source circuit feeding the crystal oven (if any) shall be arranged to be independent of the power source for the rest of the equipment for the purposes of testing.

If the thermal balance is not checked by measurements, a temperature stabilizing period of at least one hour, or a longer period as may be decided by the testing laboratory, shall be allowed. The sequence of measurements shall be chosen, and the humidity content in the test chamber shall be controlled so that excessive condensation does not occur.

5.5.2 Procedure for equipment designed for continuous transmission

If the equipment is intended for continuous transmission, the test procedure shall be as follows.

- Before tests at the upper extreme temperature, the equipment shall be placed in the test chamber, and left until thermal balance is attained. The equipment shall then be switched on in the transmit condition with modulation T1 or T4 (as appropriate, see clause 6.3), for a period of half an hour, after which the equipment shall meet the specified requirements.
- Before tests at the lower extreme temperature, the equipment shall be left in the test chamber until thermal balance is attained, then switched to the standby or receive condition for a period of one minute, after which the equipment shall meet the specified requirements.

5.5.3 Procedure for equipment designed for intermittent transmission

If the equipment is intended for intermittent transmission, the test procedure shall be as follows.

- Before tests at the upper extreme temperature, the equipment shall be placed in the test chamber, and left until thermal balance is attained. The equipment shall then be switched on for one minute in the transmit condition with modulation T1 or T4 (as appropriate, see clause 6.3), followed by four minutes in the receive condition, after which the equipment shall meet the specified requirements.
- For tests at the lower extreme temperature, the equipment shall be left in the test chamber until thermal balance is attained, then switched to the standby or receive condition for one minute, after which the equipment shall meet the specified requirements.

5.5.4 Testing of equipment that does not have an external 50 Ω RF connector (integral antenna equipment)

Where equipment has an internal 50 Ω connector it shall be permitted to perform the tests at this connector.

Equipment may also have a temporary internal 50 Ω connector installed for the purposes of testing.

No connection shall be made to any internal permanent or temporary antenna connector during the performance of radiated emissions measurements, unless such action forms an essential part of the normal intended operation of the equipment.

6 General conditions of measurement

6.1 Arrangements for test signals applied to the receiver input

Sources of test signals for application to the receiver input shall be connected in such a way that the source impedance presented to the receiver input is 50Ω (clause 6.5) with a return loss equal to or greater than 20 dB.

This requirement shall be met irrespective of whether one or more signals using a combining network are applied to the receiver.

The effects of any intermodulation products and noise produced in the test signal sources should be negligible.

6.2 Test load (artificial antenna)

For conducted measurements of the transmitter, a power attenuator ("artificial antenna") shall be used, exhibiting a load impedance of 50Ω to the antenna connector with a return loss equal to or greater than 20 dB and capable of dissipating the transmitter output power.

6.3 Test signals (wanted and unwanted signals)

6.3.1 General

The modulation of the test signals T1, to be described below, shall comply with ETSI EN 300 392-2 [3], clause 5. The modulation filter is specified by a set of windowed discrete impulse response samples, $\{g'_j\}$, where $j = 0 \dots N-1$, and

$$g'_j = w_j g \left(TN_s \left(\frac{j}{N-1} - \frac{1}{2} \right) \right)$$

where $g(t)$ is the symbol waveform defined in ETSI EN 300 392-2 [3], clause 5, N_s is the number of symbols spanned by the filter and T is the symbol duration as defined in ETSI EN 300 392-2 [3], clause 5. N_s shall be at least 15. The window coefficients, w_j , are defined by:

$$w_j = 1 - \left(\frac{j - \frac{1}{2}(N-1)}{\frac{1}{2}(N+1)} \right)^2$$

6.3.2 Test signal T1 (TETRA wanted signal, phase modulation)

6.3.2.1 Test signal framing

The T1 signal sequence shall comply with the TETRA air interface multiframe, frame and slot/burst/sub burst structure and is the wanted signal transmitted by the test system during frames 1 to 17 in all receiver tests. The modulation type shall be $\pi/4$ -DQPSK or $\pi/8$ -D8PSK (where supported). The information transmitted by the test system in frame 18 of T1 is used for test control purposes. The slot structure of T1 in frames 1 to 17 is dependent upon the type of receiver test being conducted, defined by the channel type number.

6.3.2.2 MS testing

During MS receiver testing, the test system shall transmit in timeslot 1 of T1 continuous down link burst and channel types according to tables 2a and 2b.

On frame 18 according to table 2a.

Table 2a: Test system transmission

| Burst type | Block 1 | Block 2 | Broadcast Block |
|-----------------|---------|---------|-----------------|
| synchronization | BSCH | BNCH/T | AACH |

The BNCH/T is a logical channel specific to the test mode. The contents of the BSCH and BNCH/T to be used during the test are given in clause D.1. The Main Carrier, Frequency Band and Offset parameters contained in the BNCH/T shall indicate the downlink frequency of the T1 test signal being generated. The Duplex Spacing and Reverse Operation parameters contained in the BNCH/T shall indicate the required uplink frequency with respect to the indicated downlink frequency. These parameters are defined in ETSI EN 300 392-2 [3], clause 21.

On frame 1 to 17, one of the following channel types according to table 2b.

Table 2b: Channel types

| Channel type | Burst type | Block 1 | Block 2 | Broadcast Block |
|--------------|------------|-------------|---------|-----------------|
| 0 | normal | TCH/7,2 | | AACH |
| 1 | normal | TCH/7,2 | | AACH |
| 21 | normal | TCH-P8/10,8 | | AACH |

The T1 signal shall be scrambled according to ETSI EN 300 392-2 [3], clause 8, using the scrambling sequence generated from the 30 bits of the extended colour code, except for the BSCH where the 30 bits shall be set equal to zero. The extended colour code shall be formed from the values of MCC + MNC + BCC which are transmitted in the T1 signal BSCH information defined in table D.1. The MS under test shall use the scrambling sequence indicated by the T1 signal.

A bit stream, produced by repeating a pseudo random sequence with a length of 511 bits according to Recommendation ITU-T O.153 [1], clause 2.1, shall be used as the information to be transmitted over the logical channel to be tested. Unless otherwise specified the contents of any logical channels not currently being tested is undefined. The test system shall support at least one of the pseudo random bit sequence alternatives:

- sequence continues without breaks from one multiframe to another; or
- sequence is repeated for each multiframe starting with frame 1, timeslot 1.

The indication of the sequence type may be defined in BNCH/T, see table D.2.

NOTE: For channel type 3, the logical channels BNCH and STCH have the same coding, interleaving format and performance specification as SCH/HD and are not, therefore, specifically tested.

Channel types 1 and 21 shall be tested in continuous transmission mode where channel type 0 is inserted in time slots 2 to 4 of frames 1 to 18.

6.3.2.3 BS testing

During BS receiver testing the test system shall transmit in timeslot 1 of T1 up link burst and channel types according to tables 3a and 3b.

On frame 18 according to table 3a.

Table 3a: Test system transmission

| Channel type | Burst type | Block 1 | Block 2 |
|--------------|------------|---------|---------|
| 8 | Normal | SCH/F | |

On frame 1 to 17 one of the following channel types according to table 3b.

Table 3b: Channel types

| Channel type | Burst type | Block 1 / Sub slot 1 | Block 2 / Sub slot 2 |
|--------------|------------|----------------------|----------------------|
| 7 | normal | TCH/7,2 | |
| 21 | normal | TCH-P8/10,8 | |

For BS receiver testing, channel type 7 shall be inserted in time slots 2 to 4 of all uplink frames 1 to 18. A bit stream, produced by repeating a pseudo random sequence with a length of 511 bits according to Recommendation ITU-T O.153 [1], clause 2.1, shall be used as the information to be transmitted over the logical channel. The test system shall support at least one of the pseudo random bit sequence alternatives:

- sequence continues without breaks from one multiframe to another; or
- sequence is repeated for each multiframe starting with frame 1, timeslot 1.

NOTE: The selection of the type of pseudo random bit sequence in BS receiver testing is out of scope of the present document.

6.3.3 Test signal T2 (TETRA interferer)

The phase modulated test signal T2 is a $\pi/4$ -DQPSK modulated continuous radio signal following the structure of TETRA signals, but with all modulating bits (including training sequences) derived directly from pseudo random bit sequence (with a length of 511 bits according to Recommendation ITU-T O.153 [1], clause 2.1).

The QAM modulated test signal T2 is a 4-QAM, 16-QAM, or 64-QAM modulated continuous signal with a bandwidth of 25 kHz (T2-25), 50 kHz (T2-50), 100 kHz (T2-100), or 150 kHz (T2-150) following the structure of TETRA signals, but with all modulating symbols' underlying bits (including synchronization and pilot symbols) derived directly from pseudo random bit sequence (with a length of 511 bits according to Recommendation ITU-T O.153 [1], clause 2.1). The selection of 4-QAM, 16-QAM or 64-QAM shall be according to the requirements of the test that requires the use of test signal T2.

In each case, the bit sequence of T2 shall be decorrelated with the bit sequence used for test signal T1.

T2 is used as an unwanted (modulated) signal.

6.3.4 Test signal T3 (unmodulated interferer)

Test signal T3 is an unmodulated continuous sinusoidal radio signal. T3 is used as an unwanted (unmodulated) signal.

6.3.5 Test signal T4 (TETRA wanted signal, QAM)

6.3.5.1 Test signal structure

The T4 signal sequence shall comply with the TETRA air interface multiframe, frame and slot/burst/sub burst structure and is the wanted signal transmitted by the test system during all QAM receiver tests.

The bandwidth of T4 shall be 25 kHz, 50 kHz, 100 kHz, or 150 kHz during QAM modulation, and 25 kHz during $\pi/4$ -DQPSK modulation. The selection of 4-QAM, 16-QAM or 64-QAM shall be according to the requirements of the test that requires the use of test signal T4.

6.3.5.2 MS testing

6.3.5.2.1 Test signal usage

The slot structure of T4 for downlink in frames 1 to 17 is that of the normal downlink burst for QAM modulation.

a) CA MS testing

In the case that CA MS performance is tested, $\pi/4$ -DQPSK modulation shall be transmitted in part of frame 18. The $\pi/4$ -DQPSK information transmitted by the test system in frame 18 slot 3 of T4 is used for test control purposes. The structure of the $\pi/4$ -DQPSK transmission in frame 18 is defined in clause 6.3.5.2.2.

During CA MS receiver testing, the test system shall transmit T4 continuous down link burst and channel types according to tables 2a and 4b.

On timeslot 3 of frame 18 according to table 2a.

On frame 1 to 17 one of the channel types according to table 4b.

b) DA MS testing

In the case that DA MS performance is tested, QAM modulation shall be transmitted in part of frame 18. The 4-QAM information transmitted by the test system in frame 18 slot 1 of T4 is used for test control purposes. The structure of the QAM transmission in frame 18 is defined in clause 6.3.5.2.3.

During DA MS receiver testing, the test system shall transmit T4 continuous down link burst and channel types according to tables 4a and 4b.

On timeslot 1 of frame 18 according to table 4a.

Table 4a: Test system transmission

| Burst type | Frequency correction data set A | Slot header |
|----------------------|---------------------------------|---------------------|
| frequency correction | BSCH-Q/T | AACH-Q and SICH-Q/D |

The BSCH-Q/T is a logical channel specific to the test mode. The contents of the BSCH-Q/T to be used during the test are given in clause D.1. The Main Carrier, Frequency Band and Offset parameters contained in the BSCH-Q/T shall indicate the downlink frequency of the T4 test signal being generated. The Duplex Spacing and Reverse Operation parameters contained in the BSCH-Q/T shall indicate the required uplink frequency with respect to the indicated downlink frequency. These parameters are defined in ETSI EN 300 392-2 [3], clause 21.

On frame 1 to 17 one of the channel types according to table 4b.

c) CA and DA MS testing

During both CA MS receiver testing and DA MS receiver testing, the test system shall continuously transmit test signal T4 with channel type 27 (SCH-Q/D) in timeslot 1 of frames 1 to 17, if one slot testing is used, and in timeslots 1 to 4 of frames 1 to 17, if four slots testing is used.

Table 4b: Channel types

| Channel type | Burst type | Downlink data set | Slot header |
|--------------|------------|-------------------|---------------------|
| 27 | normal | SCH-Q/D | AACH-Q and SICH-Q/D |
| 27a | normal | SCH-Q/D | AACH-Q and SICH-Q/D |

The pseudo random bit sequence continues from one used slot to another. If one slot testing is used, the test system shall continuously transmit test signal T4 with channel type 27a (SCH-Q/D) in timeslots 2 to 4 of frames 1 to 17. Channel type 27a is not intended to be received and decoded by the MS under test; its content is undefined and is independent of the content of channel type 27. The test system shall transmit on frame 18 according to clause 6.3.5.2.2. The T4 signal shall be scrambled according to ETSI EN 300 392-2 [3], clause 8, using the scrambling sequence generated from the 30 bits of the extended colour code, except for the BSCH or BSCH-Q/T where the 30 bits shall be set equal to zero. The extended colour code shall be formed from the values of MCC + MNC + BCC which are transmitted in the T4 signal BSCH information defined in table D.1 or BSCH-Q/T information defined in table D.3. The MS under test shall use the scrambling sequence indicated by the T4 signal.

A bit stream, produced by repeating a pseudo random sequence with a length of 511 bits according to Recommendation ITU-T O.153 [1], clause 2.1, shall be used as the information to be transmitted over the logical channel to be tested. The test system shall support at least one of the pseudo random bit sequence alternatives:

- sequence continues without breaks from one multiframe to another; or
- sequence is repeated for each multiframe starting with frame 1, timeslot 1.

The indication of the sequence type may be defined in BNCH/T, see table D.2 and in BSCH-Q/T, see table D.3.

The SICH-Q/D logical channel and the AACH-Q logical channel do not provide valid control information in the T4 test signal: each logical channel carries a separate continuous pseudo random bit sequence of length 511 bits which is independent of the bit sequence in the SCH-Q/D logical channel. Unless otherwise specified the contents of any logical channels not currently being tested is undefined.

NOTE 1: QAM-SLOTINFO has no meaning in the slot header of data stream, which follows the T4 signal. Modulation and code rate information in these slots is indicated by the information element QAM_payload_type in BSCH-Q/T, BNCH-Q/T or BNCH/T channel.

One or four slots may be used for test data, when MS is tested. Whether one slot or four slots are used for testing is defined by the element "test signal width" in BNCH/T as defined in table D.2 and BSCH-Q/T as defined in table D.3.

NOTE 2: When four slots testing is made the test connection TTCI needs to support higher data rate.

NOTE 3: Four slots testing is not compatible with the RF loopback tests.

6.3.5.2.2 Use of synchronization burst in frame 18 when testing CA MSs

Figure 1 illustrates the method in which the test equipment's power, modulation type and RF bandwidth vary with time in the T4 signal.

In figure 1, a phase modulation synchronization continuous downlink burst is transmitted during frame 18 slot 3. The QAM signal under test is transmitted during all slots of frames 1 to 17.

The MS under test shall monitor the BNCH/T logical channel transmitted in frame 18 slot 3 in order to detect any changes in the type of test being indicated.

Figure 1 shows that frame 17 slot 4 contains a QAM burst transmitted at the RF power level P_Q required for the particular QAM FER and BER measurement in QAM bandwidth f_Q (which may be 25 kHz, 50 kHz, 100 kHz or 150 kHz, according to the test in progress).

Frame 18 slot 1 contains the first two symbols $SN-Q1$ and $SN-Q2$ of a new QAM burst at the same RF power level and RF bandwidth – these contain synchronization pilot symbols and are provided to allow the MS to interpolate back into frame 17 slot 4 for channel estimation purposes.

From just after the symbol time of $SN-Q2$ until 0,5 QAM symbol periods after symbol time $SN-Q4$ the test equipment may ramp its QAM signal down to zero RF level (i.e. from 3 750/9 μ s until 13 125/9 μ s after the start of slot 1). After ramping down the RF output shall then remain at zero power until symbol time $SN133$ of slot 2).

NOTE: A slot starts at symbol times $SN0$ and $SN-Q1$ (ETSI EN 300 392-2 [3], clauses 7.3.2 and 7.4.1).

Frame 18 slot 1 after $SN-Q2$ is used for the QAM frequency correction burst (FCB) when DA MS performance is tested, see clause 6.3.5.2.3. A CA MS is not required to decode any transmissions it receives in frame 18 slot 1 after $SN-Q2$.

After the symbol time $SN133$ of slot 2 (i.e. 66 500/9 μ s after the start of slot 2), the test equipment shall ramp up and transmit $\pi/4$ -DQPSK symbols. This transmission shall be at the same power as frame 18 slot 3 and may be used by the MS for AGC purposes. The test equipment shall transmit a synchronization continuous down-link burst in slot 3, commencing with the first five symbols of the $\pi/4$ -DQPSK normal training sequence 3 as symbols $SN251$ to $SN255$ of frame 18 slot 2 (slot 2 symbol time $SN251$ occurs 125 500/9 μ s after the start of slot 2).

The synchronization continuous downlink burst sent in slot 3 has the form shown for the T1 test signal in clause 6.3.2 for frame 18 slot 1 of the T1 test signal. It contains BSCH in block 1 and BNCH/T in block 2. The synchronization continuous downlink burst includes the $\pi/4$ -DQPSK normal training sequence 3 at the start and end of slot 3. The last six symbols of the $\pi/4$ -DQPSK normal training sequence 3 at the end of slot 3 extend into slot 4, comprising symbols $SN1$ to $SN6$ of slot 4. The $\pi/4$ -DQPSK signalling shall be transmitted in a 25 kHz bandwidth.

The phase modulation transmission shall be aligned so that symbol time $SN0$ for slot 3 occurs $255\,000/9\ \mu\text{s} \pm 125/9\ \mu\text{s}$ after the start of frame 18 slot 1. The centre frequency of the phase modulation transmission shall be the same as the centre frequency of the QAM channel.

The mean power level of the phase modulation transmission should be user-adjustable in the range -115 dBm to -20 dBm. The mean power level of the QAM transmission in frames 1 to 17 may be above or below this level, depending on the type of test.

Transmission of phase modulation stops at the end of the $\pi/4$ -DQPSK normal training sequence 3 that terminates on symbol $SN6$ of frame 18 slot 4 (i.e. at $3\,000/9\ \mu\text{s}$ after the start of slot 4). The phase modulation is ramped down to zero RF power from symbol times $SN6$ until $SN21$ (i.e. from $3\,000/9\ \mu\text{s}$ until $10\,500/9\ \mu\text{s}$ after the start of slot 4).

The phase modulation signal completes its ramp down 0,2 QAM symbol periods ($750/9\ \mu\text{s}$) before symbol time $SN-Q4$ of slot 4 (i.e. at $10\,500/9\ \mu\text{s}$ after the start of slot 4). Starting at symbol time $SN-Q25$ the test generator shall ramp up and transmit QAM symbols. The mean power of this transmission shall be same as in frame 1 slot 1. This transmission may be used by the MS for AGC purposes.

The QAM transmission commencing at $SN-Q25$ of frame 18 slot 4 shall be aligned so that $SN-Q1$ of frame 1 slot 1 occurs at $510\,000/9\ \mu\text{s} \pm 125/9\ \mu\text{s}$ after the start of frame 18 slot 1 and $255\,000/9\ \mu\text{s} \pm 125/9\ \mu\text{s}$ after the symbol time of the $SN0$ symbol that was transmitted in frame 18 slot 3.

The MS under test may use the phase modulation synchronization bursts to obtain initial frequency and time synchronization to an accuracy of $\pm 100\ \text{Hz}$ and $\pm 125/9\ \mu\text{s}$ (1/4 of a phase modulation symbol). It may then maintain this synchronization until frame 1 slot 1, and obtain fine synchronization from the QAM pilot symbols. Normally the MS is expected to maintain QAM synchronization, so it should not be necessary for the MS to resynchronize on subsequent phase modulation bursts.

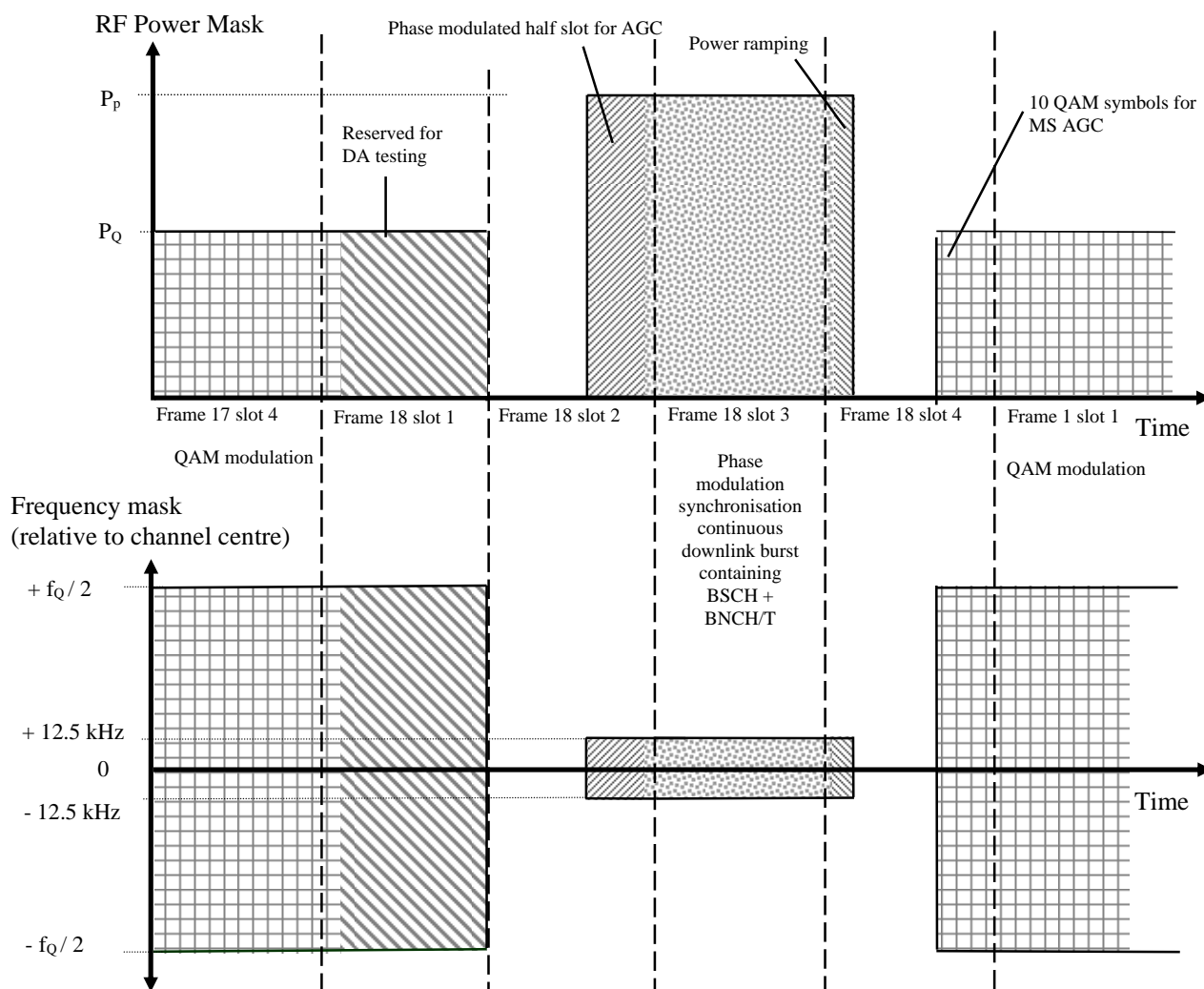

Figure 1: Variation of power, modulation type and frequency in a T4 signal for CA testing

6.3.5.2.3 Use of frequency correction burst in frame 18 when testing DA MSs

Figure 2 illustrates the method in which the test equipment's power, modulation type and RF bandwidth vary with time in the T4 signal.

In figure 2, a QAM frequency correction burst (FCB) is transmitted during frame 18 slot 1. The QAM signal under test is transmitted during all slots of frames 1 to 17.

The MS under test shall monitor the BSCH-Q/T logical channel transmitted in frame 18 slot 1 in order to detect any changes in the type of test being indicated. In case continuous QAM transmission is used, the slots 2 to 4 in frame 18 include SCH-Q/D without any useful information.

Figure 2 shows that frame 17 slot 4 contains a QAM burst transmitted at the RF power level P_Q required for the particular QAM FER and BER measurement in QAM bandwidth f_Q (which may be 25 kHz, 50 kHz, 100 kHz or 150 kHz, according to the test in progress).

The FCB shall be transmitted with the same RF bandwidth, frequency and mean power level as the transmissions in frames 1 to 17.

During the period between symbol time of $SN-Q2$ of slot 2 and 0,5 QAM symbol periods after symbol time $SN-Q4$ of slot 2 (i.e. from $3\ 750/9\ \mu\text{s}$ until $13\ 125/9\ \mu\text{s}$ after the start of slot 2) the QAM transmission may ramp down to zero RF level. The RF output shall then remain at zero power until at least symbol time $SN133$ of slot 2 (i.e. $66\ 500/9\ \mu\text{s}$ after the start of slot 2). Alternatively, the QAM transmission may be continuous over the frame 18.

NOTE 1: A slot starts at symbol times SN_0 and $SN-Q_1$ (ETSI EN 300 392-2 [3], clauses 7.3.2 and 7.4.1).

In frame 18 slot 4 starting at symbol time $SN-Q_{25}$ the test generator shall ramp up (if not already transmitting) and shall transmit QAM symbols. The mean power of this transmission shall be same as in frame 1 slot 1. This transmission may be used by the MS for AGC purposes.

The QAM transmission commencing at $SN-Q_{25}$ of frame 18 slot 4 shall be aligned so that $SN-Q_1$ of frame 1 slot 1 occurs at $510\,000/9\ \mu\text{s} \pm 125/9\ \mu\text{s}$ after the start of frame 18 slot 1.

The MS under test may use the FCB to obtain initial frequency and time synchronization to an accuracy of $\pm 100\ \text{Hz}$ and $\pm 125/9\ \mu\text{s}$. The MS is then expected to maintain QAM synchronization from the QAM pilot symbols in the SCH-Q/D transmissions in frames 1 to 17. It should not be necessary for the MS to resynchronize on subsequent FCBs.

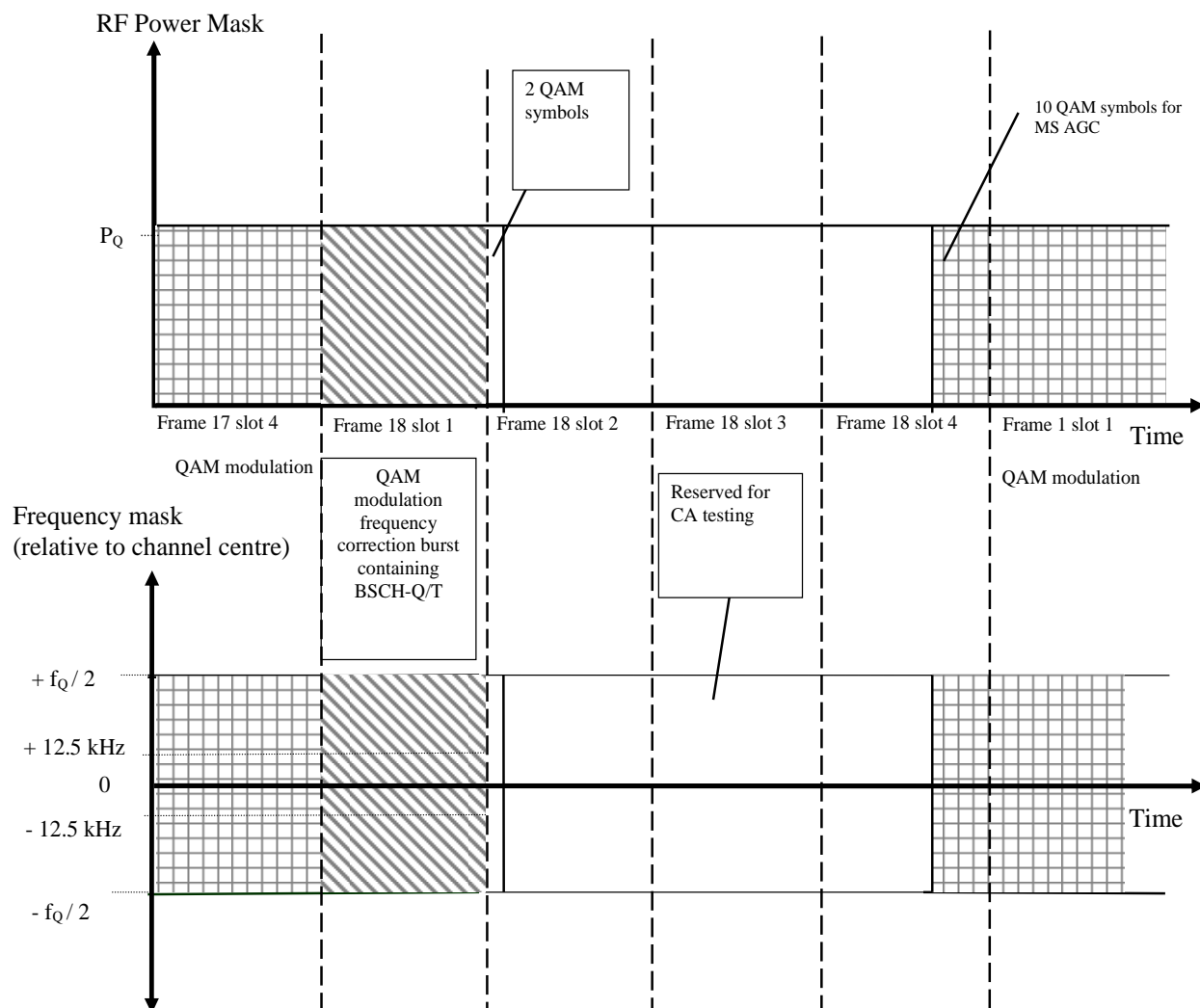

Figure 2: Variation of power, modulation type and frequency in a T4 signal for DA testing

NOTE 2: It is permitted to combine T4 signal in frame 18 slot 1 as described in figure 1 and T4 signal in frame 18 slot 3 as described in figure 2 in a single burst.

6.3.5.3 BS testing

During BS receiver testing the test system shall transmit test signal T4 in uplink timeslot 1, or in case four slots testing is made in all four timeslots, and channel types according to tables 5a and 5b.

On frame 18 according to table 5a.

Table 5a: Test system transmission in frame 18

| Channel type | Burst type | Sub slot 1 | Sub slot 2 |
|--------------|------------|------------|------------|
| 26 | Normal | SCH-Q/U | |

On frame 1 to 17 one of the following channel types according to table 5b.

Table 5b: Test system transmission in frames 1 ... 17

| Channel type | Burst type | Sub slot 1 | Sub slot 2 |
|--------------|------------|------------|------------|
| 25 | Control | SCH-Q/HU | SCH-Q/HU |
| 26 | Normal | SCH-Q/U | |

In case channel type 25 is used the data stream is inserted in Sub slot 1 and Sub slot 2.

In each case, a valid SICH-Q/U for the modulation used during the test shall be mapped onto the header block of each uplink slot or sub slot.

For BS receiver testing, in case 1 slots testing is made, channel type 26 shall be inserted in time slots 2 to 4 of all uplink frames 1 to 17. A bit stream, produced by repeating a pseudo random sequence with a length of 511 bits according to Recommendation ITU-T O.153 [1], clause 2.1, shall be used as the information to be transmitted over the logical channel. The test system shall support at least one of the pseudo random bit sequence alternatives:

- sequence continues without breaks from one multiframe to another; or
- sequence is repeated for each multiframe starting with frame 1, timeslot 1.

NOTE: The selection of the type of pseudo random bit sequence in BS receiver testing is out of scope of the present document.

6.4 Transceiver data interface

Equipment that does not integrate the keyboard and display used for normal operation shall either provide a standardized interface (preferably) or other suitable (proprietary) interfaces.

In the case where the equipment uses a proprietary interface, appropriate means and documentation allowing for the equipment to be tested are expected to be provided with the measurements.

Variation in the level of the input signals, within the specified limits for that interface, shall have no measurable influence on the characteristics of the signals on the radio path.

6.5 Duplex equipment

If the equipment is provided with a built-in duplex filter or with a separate associated filter, the requirements of the present document shall be met when the measurements are carried out using the antenna connector of the filter.

Duplex equipment having integral antenna may be tested using the internal or temporary antenna connector.

6.6 Measurement filter definition

For power measurements on $\pi/4$ -DQPSK and $\pi/8$ -D8PSK modulated signals the measurement filter shall be a linear phase filter which is defined by the magnitude of its frequency response:

$$|H(f)| = G(f).$$

$$G(f) = 1 \quad \text{for} \quad |f| \leq (1 - \alpha)/2T$$

$$G(f) = \sqrt{0.5(1 - \sin(\pi(2|f|T - 1)/2\alpha))} \quad \text{for} \quad (1 - \alpha)/2T \leq |f| \leq (1 + \alpha)/2T$$

$$G(f) = 0 \quad \text{for} \quad |f| \geq (1 + \alpha)/2T$$

Where:

- T is the symbol duration;
- α is the roll-off factor, which determines the width of the filter band at a given symbol rate.

The value of α shall be 0,35.

The symbol rate shall be 18 000 symbols per second for $\pi/4$ -DQPSK modulated signals and 27 000 symbols per second for $\pi/8$ -D8PSK modulated signals.

For power measurements on QAM modulated signals the measurement filter is defined in ETSI EN 300 392-2 [3], clause 5.17.

6.7 TMO Repeaters

A repeater can be designed to amplify the whole transmit RF band or just a part of the band. In the latter case the repeater can be either broadband, with frequency band selective filtering, or channelized, with channel selective filtering.

For TMO Repeater equipment the following conditions shall apply:

- the equipment shall be operated at maximum gain unless otherwise specified;
- measurements apply to both the uplink and downlink direction of the repeater;
- as appropriate for the transmitter tests, the relevant antenna input port of the repeater shall be connected to a RF signal generator which shall excite the repeater with a continuous RF signal modulated with test signal T1 or T4 as appropriate; the input level to the repeater shall be increased, until the maximum rated output power per channel is reached.

Information and background on test methods and configuration of this type of equipment can be found in ETSI TS 101 789-1 [i.3] with further relevant information available in ETSI EN 300 394-1 [i.4] and ETSI EN 303 035-1 [i.5].

7 Technical characteristics of the transmitter

7.1 Transmitter output power (conducted)

7.1.1 Definitions

The P_A of the transmitter is the average power during the useful part of the burst as defined in ETSI EN 300 392-2 [3], clause 9.4.

The power classes and associated nominal power levels shall be those at which the transmitter is intended to operate, and shall be according those specified in ETSI EN 300 392-2 [3], clause 6.4.

7.1.2 Method of measurement

The measurement shall be performed with test signal T1 or T4 (as appropriate, see clause 6.3) applied at the transmitter. The modulation used shall be recorded in the test report. The transmitter or test arrangement may be operated in a test mode which excludes BLCH and CLCH transmissions.

The transmitter shall be set in continuous transmission mode. If this is not possible, the measurements shall be carried out during the useful part of the transmitted burst. If the output power of the transmitter is adjustable the maximum output level shall be selected.

For a phase modulated transmitter, the measurement may be made by a power measuring device that is synchronized to the symbol rate and incorporates the measurement filter defined in clause 6.6 or by a fast-acting power measuring device that is not synchronized to the symbol rate. Within each burst, the measurement shall take an average over at least 200 symbols in a phase modulated burst. When using an unsynchronized power meter the measurement filter shall not be used.

For a QAM transmitter, the measurement may be made by measuring the power of each sub-carrier using a power measuring device that is synchronized to the symbol rate and incorporates the measurement filter defined in ETSI EN 300 392-2 [3], clause 5.17, and calculating the transmitter power by summing the results of the measurements of every sub-carrier. Alternatively, a fast-acting power measuring device that is not synchronized to the symbol rate may be utilized. Within each QAM burst, the measurement shall take an average over at least 26 symbols. When using an unsynchronized power meter a measurement filter shall not be used.

The P_A of the transmitter shall be measured and averaged over at least 20 bursts.

For a TMO repeater, the measurements shall be performed in both the uplink and downlink direction, at maximum and minimum gain and on channels at the upper and lower limits of operational frequency band of the repeater, in accordance with the intended operation of the equipment.

The measurement shall be conducted at one each of the lowest, middle and highest radio frequency channels of the transmit band (see clause 4.1.2).

The measurement shall be made under normal test conditions (see clause 5.3) and extreme test conditions (see clauses 5.4.1 and 5.4.2).

7.1.3 Limits

The measured P_A under normal and extreme test conditions shall be within the limits stated in tables 6a, 6b, 6c or 6d according to power class.

Table 6a: Power limits for BS for phase modulation

| Power class | Minimum power under normal test conditions | Maximum power under normal test conditions | Minimum power under extreme test conditions | Maximum power under extreme test conditions |
|-------------|--|--|---|---|
| 1 (40 W) | 44 dBm | 48 dBm | 42 dBm | 49 dBm |
| 2 (25 W) | 42 dBm | 46 dBm | 40 dBm | 47 dBm |
| 3 (15 W) | 40 dBm | 44 dBm | 38 dBm | 45 dBm |
| 4 (10 W) | 38 dBm | 42 dBm | 36 dBm | 43 dBm |
| 5 (6,3 W) | 36 dBm | 40 dBm | 34 dBm | 41 dBm |
| 6 (4 W) | 34 dBm | 38 dBm | 32 dBm | 39 dBm |
| 7 (2,5 W) | 32 dBm | 36 dBm | 30 dBm | 37 dBm |
| 8 (1,6 W) | 30 dBm | 34 dBm | 28 dBm | 35 dBm |
| 9 (1 W) | 28 dBm | 32 dBm | 26 dBm | 33 dBm |
| 10 (0,6 W) | 26 dBm | 30 dBm | 24 dBm | 31 dBm |

Table 6b: Power limits for BS for QAM

| Power class | Minimum power under normal test conditions | Maximum power under normal test conditions | Minimum power under extreme test conditions | Maximum power under extreme test conditions |
|-------------|--|--|---|---|
| 1 (40 W) | 44 dBm | 48 dBm | 42 dBm | 49 dBm |
| 2 (25 W) | 42 dBm | 46 dBm | 40 dBm | 47 dBm |
| 3 (15 W) | 40 dBm | 44 dBm | 38 dBm | 45 dBm |
| 4 (10 W) | 38 dBm | 42 dBm | 36 dBm | 43 dBm |
| 5 (6,3 W) | 36 dBm | 40 dBm | 34 dBm | 41 dBm |
| 6 (4 W) | 34 dBm | 38 dBm | 32 dBm | 39 dBm |
| 7 (2,5 W) | 32 dBm | 36 dBm | 30 dBm | 37 dBm |
| 8 (1,6 W) | 30 dBm | 34 dBm | 28 dBm | 35 dBm |
| 9 (1 W) | 28 dBm | 32 dBm | 26 dBm | 33 dBm |
| 10 (0,6 W) | 26 dBm | 30 dBm | 24 dBm | 31 dBm |

Table 6c: Power limits for MS for phase modulation

| Power class | Minimum power under normal test conditions | Maximum power under normal test conditions | Minimum power under extreme test conditions | Maximum power under extreme test conditions |
|--------------|--|--|---|---|
| 1 (30 W) | 43 dBm | 47 dBm | 41 dBm | 48 dBm |
| 1L (17,5 W) | 40,5 dBm | 44,5 dBm | 38,5 dBm | 45,5 dBm |
| 2 (10 W) | 38 dBm | 42 dBm | 36 dBm | 43 dBm |
| 2L (5,6 W) | 35,5 dBm | 39,5 dBm | 33,5 dBm | 40,5 dBm |
| 3 (3 W) | 33 dBm | 37 dBm | 31 dBm | 38 dBm |
| 3L (1,8 W) | 30,5 dBm | 34,5 dBm | 28,5 dBm | 35,5 dBm |
| 4 (1 W) | 28 dBm | 32 dBm | 26 dBm | 33 dBm |
| 4L (0,56 W) | 25,5 dBm | 29,5 dBm | 23,5 dBm | 30,5 dBm |

Table 6d: Power limits for MS for QAM

| Power class | Minimum power under normal test conditions | Maximum power under normal test conditions | Minimum power under extreme test conditions | Maximum power under extreme test conditions |
|--------------|--|--|---|---|
| 1 (30 W) | 43 dBm | 47 dBm | 41 dBm | 48 dBm |
| 1L (17,5 W) | 40,5 dBm | 44,5 dBm | 38,5 dBm | 45,5 dBm |
| 2 (10 W) | 38 dBm | 42 dBm | 36 dBm | 43 dBm |
| 2L (5,6 W) | 35,5 dBm | 39,5 dBm | 33,5 dBm | 40,5 dBm |
| 3 (3 W) | 33 dBm | 37 dBm | 31 dBm | 38 dBm |
| 3L (1,8 W) | 30,5 dBm | 34,5 dBm | 28,5 dBm | 35,5 dBm |
| 4 (1 W) | 28 dBm | 32 dBm | 26 dBm | 33 dBm |
| 4L (0,56 W) | 25,5 dBm | 29,5 dBm | 23,5 dBm | 30,5 dBm |
| 5 (0,32 W) | 23 dBm | 27 dBm | 21 dBm | 28 dBm |
| 5L (0,18 W) | 20,5 dBm | 24,5 dBm | 18,5 dBm | 25,5 dBm |

7.2 Adjacent and alternate channel power

7.2.1 Definition

The adjacent channel power is that part of the total output power of a transmitter, under defined conditions of modulation, which falls within specified passbands centred on the nominal frequency of either of the adjacent channels.

The alternate channel power is that part of the total output power of a transmitter, under defined conditions of modulation, which falls within specified passbands centred on the nominal frequency of any of the alternate channels.

The adjacent and alternate channels are defined as having channel bandwidths of 25 kHz, the specified passband of which is equal to the bandwidth of a square root raised cosine filter given in clause 6.6. The adjacent, alternate and wanted channels are depicted in figure 3.

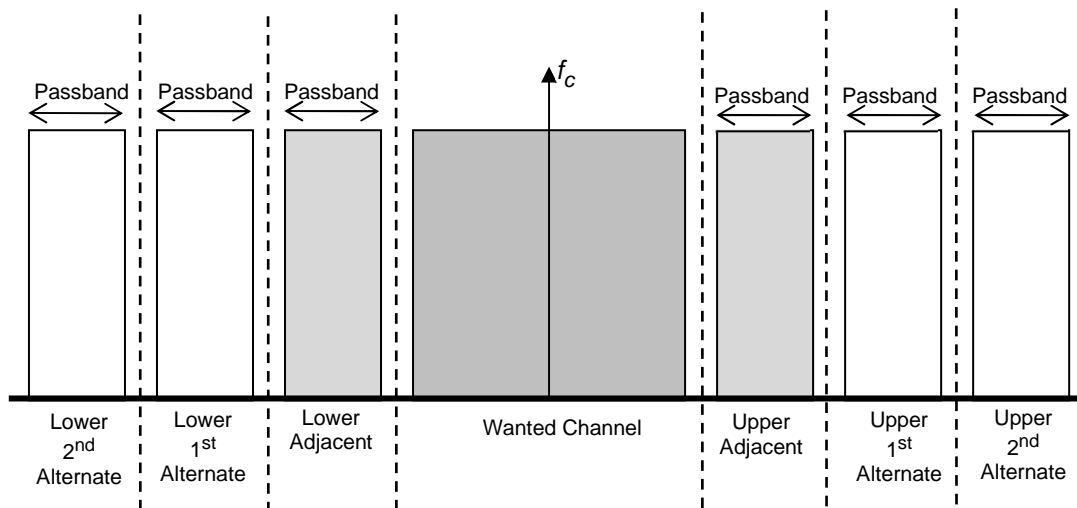

NOTE: This measurement is complemented by adjacent channel transient power measurements.

Figure 3: Adjacent and alternate channel definitions

7.2.2 Method of measurement

The test shall be conducted in one of the middle radio frequency channels of the equipment's transmit band (see clause 4.1.2) and in the case of MS and BS equipment repeated at minimum power level.

The transmitter or test arrangement may be operated in a test mode which excludes BLCH and CLCH transmissions.

The transmitter shall be operated at the value of P_A determined under normal test conditions.

The transmitter shall be modulated with test signal T1 or T4 as appropriate. The modulation used shall be recorded in the test report.

The transmitter shall be set in continuous transmission mode. If continuous transmission mode is not possible, the measurements shall be timed to occur only during the useful part of the burst, the measurements including at least 200 symbols in each phase modulated burst or 26 symbols in each QAM burst.

The 0 dB reference for the transmitter output power shall be obtained by either using the method described in clause 7.1 or by direct measurement by the adjacent and alternate channel power measurement equipment (e.g. a spectrum analyser) with the bandwidth of the equipment adjusted to measure the power of the full bandwidth of the wanted signal.

The adjacent and alternate channel powers shall be measured through measurement filter defined in clause 6.6 or using a spectrum analyser with the bandwidth set to 18 kHz.

If using a power measuring receiver with the measurement filter defined in clause 6.6, the measurement filter shall be centred on the frequency defined in table 7 as the centre of the adjacent channel. Alternatively a spectrum analyser with a bandwidth set to 18 kHz may be used. The power averaged over at least 20 bursts shall be recorded (the adjacent channel power). The measurement shall be carried out for both of the upper and lower adjacent channels. The measurement shall be made under normal test conditions (see clause 5.3) and repeated under extreme test conditions (clauses 5.4.1 and 5.4.2 applied simultaneously).

The adjacent channel power ratio is the difference (in dB) between the measured wanted channel power (P_A) and the largest adjacent channel power resulting from the measurements of the two channels above and below the wanted channel.

The measurement shall be repeated with the measurement filter centred on the frequencies defined in table 7 for the upper and lower 1st and 2nd alternate channels. The average power measured through the measurement filter averaged over at least 20 bursts shall be recorded (the alternate channel power). The measurement shall be made under normal test conditions (see clause 5.3) and repeated under extreme test conditions (see clauses 5.4.1 and 5.4.2 applied simultaneously).

The alternate channel power ratio is the difference (in dB) between the measured wanted channel power and the largest alternate channel power from the two alternate channels above and below the wanted channel.

Table 7: Summary of measurement offset

| | 25 kHz Channels | 50 kHz Channels | 100 kHz Channels | 150 kHz Channels |
|---|-----------------|-----------------|------------------|------------------|
| Nominal Channel Bandwidth (for measurement of P_A) | 25 kHz | 50 kHz | 100 kHz | 150 kHz |
| Centre of Adjacent Channel (relative to centre of the nominal channel) | ±25 kHz | ±37,5 kHz | ±62,5 kHz | ±87,5 kHz |
| Centre of 1st Alternate Channel (relative to centre of the nominal channel) | ±50 kHz | ±62,5 kHz | ±87,5 kHz | ±112,5 kHz |
| Centre of 2nd Alternate Channel (relative to centre of the nominal channel) | ±75 kHz | ±87,5 kHz | ±112,5 kHz | ±137,5 kHz |

For TMO Repeater equipment this test shall be performed in both the uplink and downlink direction at the centre of the repeaters operating band.

7.2.3 Limits

7.2.3.1 Limits for TMO Repeaters

The limits detailed in the following table 8a shall not be exceeded for adjacent channel power.

Table 8a: Maximum adjacent and alternate channel power for TMO repeater equipment

| Frequency offset | Maximum Level at normal test conditions | Maximum Level at extreme test conditions |
|--------------------------|---|--|
| Adjacent channel | -60 dBc | -50 dBc |
| Alternate channel | -70 dBc | -60 dBc |
| Second alternate channel | -70 dBc | -60 dBc |

At no offset shall the level of ACP need to be below 0,2 µW (-36 dBm), under both normal and extreme conditions.

7.2.3.2 Limits for BS and MS equipment

7.2.3.2.1 Limit values for phase modulation

The limit values given in tables 8b to 8d shall not be exceeded at the listed frequency offsets from the nominal carrier frequency. For frequencies below 700 MHz, tables 8b and 8c apply. For frequencies above 700 MHz, table 8d applies.

Table 8b: Maximum adjacent and alternate channel power levels for MS power classes 4 and 4L

| Frequency offset | Maximum level (normal test conditions) | Maximum level (extreme test conditions) |
|------------------|--|---|
| 25 kHz | -55 dBc | -45 dBc |
| 50 kHz | -70 dBc | -60 dBc |
| 75 kHz | -70 dBc | -60 dBc |

Table 8c: Maximum adjacent and alternate channel power levels for other power classes

| Frequency offset | Maximum level (normal test conditions) | Maximum level (extreme test conditions) |
|------------------|---|--|
| 25 kHz | -60 dBc | -50 dBc |
| 50 kHz | -70 dBc | -60 dBc |
| 75 kHz | -70 dBc | -60 dBc |

Table 8d: Maximum adjacent and alternate channel power levels for frequencies above 700 MHz

| Frequency offset | Maximum level (normal test conditions) | Maximum level (extreme test conditions) |
|---|---|--|
| 25 kHz | -55 dBc | -45 dBc |
| 50 kHz | -65 dBc | -55 dBc |
| 75 kHz | -65 dBc (note 1) | -55 dBc (note 2) |
| NOTE 1: A level of -70 dBc shall apply for BS Power Classes 1, 2 and 3 and for MS Power Classes 1 and 1L. | | |
| NOTE 2: A level of -60 dBc shall apply for BS Power Classes 1, 2 and 3 and for MS Power Classes 1 and 1L. | | |

These requirements shall be measured under normal and extreme test conditions. In any case, no requirement less than -36 dBm shall apply i.e. the maximum power level need not be less than -36 dBm.

NOTE: 0 dBc refers to the P_A of the BS or MS.

7.2.3.2.2 Limit values for QAM

The levels given in tables 8e, 8f, 8g and 8h shall not be exceeded at the listed frequency offsets from the nominal carrier frequency.

Table 8e: Maximum adjacent and alternate power levels for 25 kHz QAM

| Frequency offset | Maximum level for MS and BS |
|------------------|--------------------------------|
| 25 kHz | -55 dBc |
| 50 kHz | -65 dBc |
| 75 kHz | -67 dBc |

Table 8f: Maximum adjacent and alternate power levels for 50 kHz QAM

| Frequency offset | Maximum level for MS and BS |
|------------------|--------------------------------|
| 37,5 kHz | -55 dBc |
| 62,5 kHz | -63 dBc |
| 87,5 kHz | -65 dBc |

Table 8g: Maximum adjacent and alternate power levels for 100 kHz QAM

| Frequency offset | Maximum level for MS and BS |
|------------------|--------------------------------|
| 62,5 kHz | -55 dBc |
| 87,5 kHz | -60 dBc |
| 112,5 kHz | -60 dBc |

Table 8h: Maximum adjacent and alternate power levels for 150 kHz QAM

| Frequency offset | Maximum level for MS and BS |
|------------------|-----------------------------|
| 87,5 kHz | -55 dBc |
| 112,5 kHz | -60 dBc |
| 137,5 kHz | -60 dBc |

For extreme test conditions, add 10 dB to the maximum level. These requirements shall be measured under normal and extreme test conditions. In any case, no requirement less than -36 dBm shall apply i.e. the maximum power level need not be less than -36 dBm.

7.3 Unwanted emissions in the spurious domain

7.3.1 Definition

Spurious emissions are emissions on a frequency, or frequencies, which are outside the necessary bandwidth and the level of which may be reduced without affecting the corresponding transmission of information. Spurious emissions include harmonic emissions, parasitic emissions, intermodulation products and frequency conversion products but exclude out of band emissions in the adjacent channels, the first alternate channels and the second alternate channels. For the purpose of the present document the transition point between spurious domain and the out of band domain is taken as 12,5 kHz less than the centre frequency of the lower second alternate channel, and 12,5 kHz greater than the centre frequency of the upper second alternate channel, where the adjacent and alternate channels are those defined in clause 7.2.1.

This test shall be carried out at one of the middle frequency radio channels of the operating frequency range of the transmitter (see clause 4.1.2).

For TMO Repeater equipment this test shall be performed in both the uplink and downlink direction at the centre of the repeaters operating band.

For TMO Repeater equipment the measurements shall be performed for frequency offsets from the carrier frequency greater than 600 kHz under the following two conditions:

- i) Without any RF input signal. The relevant input antenna port of the repeater shall be terminated with 50 Ω .
- ii) With a continuous sinusoidal RF input signal at the centre of the repeaters operating band.

For TMO Repeater the Tx Standby function is not applicable.

7.3.2 Method of measuring the power level

7.3.2.1 Measurement options

The level of spurious emissions shall be considered to be either:

- a) their power level in a specified load (conducted spurious emission); and
- b) their effective radiated power when radiated by the cabinet and structure of the equipment (cabinet radiation);
or
- c) their effective radiated power when radiated by the cabinet and by the integral antenna, in the case of hand portable equipment fitted with such an antenna and no external RF connector.

NOTE: There only two options allowed either both a) and b) or only c).

In addition equipment shall be specifically measured for wideband noise.

7.3.2.2 Method of measuring conducted spurious emissions

This method applies only to equipment with an external 50 Ω antenna connector.

Spurious emissions shall be measured as the mean power level of any signal delivered into a 50 Ω load. This may be done by connecting the transmitter output through an attenuator to either a spectrum analyser (see also annex C) or selective voltmeter or by monitoring the relative levels of the spurious signals delivered to an artificial antenna (see clause 6.2).

The transmitter shall be modulated with the test signal T1 or T4 (as appropriate, see clause 6.3). If possible, the modulation should be continuous for the duration of the measurement. For BS and MS equipment measurements made over the frequency range 30 MHz to 4 GHz. For TMO repeater equipment measurements made over the frequency range 9 kHz to 4 GHz. For equipment operating on frequencies above 470 MHz the measurements shall also be performed over the frequency range 4 GHz to 12,75 GHz if emissions are detected within 10 dB of the specified limit between 1,5 GHz and 4 GHz.

The measurements shall be performed excluding the operating channel of the transmitter and the out of band domain defined in clause 7.3.1.

As a general rule, the resolution bandwidth of the measuring receiver should be equal to the reference bandwidth as given in clause 7.3.3 (see note). The bandwidth used in this measurement for each spurious emission shall be sufficiently narrow to reject emissions in the out of band domain defined in clause 7.3.1.

For BS and MS equipment the measurement shall be repeated with the transmitter in the "stand-by" position.

NOTE: *"To improve measurement accuracy, sensitivity and efficiency, the resolution bandwidth can be different from the reference bandwidth. When the resolution bandwidth is smaller than the reference bandwidth, the result should be integrated over the reference bandwidth. When the resolution bandwidth is greater than the reference bandwidth, the result for broadband spurious emissions should be normalised to the bandwidth ratio. For discrete spurious emissions, normalisation is not applicable, while integration over the reference bandwidth is still applicable;"* (extract from CEPT/ERC/REC 74-01 [i.1], note 5, page 4).

7.3.2.3 Method of measuring radiated spurious emissions

This method applies only to equipment with an external antenna connector.

On a test site, selected from annex B, the equipment shall be placed at the specified height on a non-conducting support and in the position closest to normal use in accordance with the intended operation of the equipment.

The transmitter antenna connector shall be connected to an artificial antenna (see clause 6.2).

The output of the test antenna shall be connected to a measuring receiver.

The test antenna shall be orientated for vertical polarization and the length of the test antenna shall be chosen to correspond to the frequency of the measuring receiver.

The transmitter shall be switched on with TETRA modulation, and the measuring receiver shall be tuned over the frequency range 30 MHz to 4 GHz, except for the operating channel of the transmitter and the out of band domain defined in clause 7.3.1. At each frequency at which a discrete spurious component is detected, the test antenna shall be raised and lowered through the specified range of heights until a maximum signal level is detected on the measuring receiver.

When a test site according to clause B.1.2 is used there is no need to vary the height of the antenna.

The transmitter shall then be rotated through 360° in the horizontal plane, until the maximum signal level is detected by the measuring receiver.

The transmitter shall be modulated by the test signal T1 or T4 (as appropriate, see clause 6.3). If possible, the modulation should be continuous for the duration of the measurement. When burst transmission is used, the mean power of any spurious emissions shall be measured using averaging over the duration of the burst. The measuring receiver shall measure the mean power and this power shall be noted. The horizontal and vertical orientation of the antenna shall also be noted.

The transmitter shall be replaced by a substitution antenna as defined in clause B.1.6.

The substitution antenna shall be orientated for vertical polarization and the length of the substitution antenna shall be adjusted to correspond to the frequency of the spurious component detected.

The substitution antenna shall be connected to a calibrated signal generator.

The frequency of the calibrated signal generator shall be set to the frequency of the spurious component detected.

The input attenuator setting of the measuring receiver shall be adjusted in order to increase the sensitivity of the measuring receiver, if necessary.

The test antenna shall be raised and lowered through the specified range of heights to ensure that the maximum signal is received.

When a test site according to clause B.1.2 is used there is no need to vary the height of the antenna.

The input signal to the substitution antenna shall be adjusted to the level that produced a level detected by the measuring receiver, that is equal to the level noted while the spurious component was measured, corrected for the change of input attenuator setting of the measuring receiver.

The input level to the substitution antenna shall be recorded as power level.

The measurement shall be repeated with the test antenna and the substitution antenna orientated for horizontal polarization.

The measure of the effective radiated power of the spurious components is the larger of the two power levels recorded for each spurious component at the input to the substitution antenna, corrected for the gain of the antenna if necessary.

For equipment operating on frequencies above 470 MHz the measurements shall also be performed over the frequency range 4 GHz to 12,75 GHz if emissions are detected within 10 dB of the specified limit between 1,5 GHz and 4 GHz.

As a general rule, the resolution bandwidth of the measuring receiver should be equal to the reference bandwidth as given in clause 7.3.3 (see note). The bandwidth used in this measurement for each spurious emission shall be sufficiently narrow to reject emissions in the operating channel of the transmitter and the out of band domain defined in clause 7.3.1.

The measurement shall be repeated with the transmitter in the "stand-by" position.

NOTE: *"To improve measurement accuracy, sensitivity and efficiency, the resolution bandwidth can be different from the reference bandwidth. When the resolution bandwidth is smaller than the reference bandwidth, the result should be integrated over the reference bandwidth. When the resolution bandwidth is greater than the reference bandwidth, the result for broadband spurious emissions should be normalised to the bandwidth ratio. For discrete spurious emissions, normalisation is not applicable, while integration over the reference bandwidth is still applicable;"* (extract from CEPT/ERC/REC 74-01 [i.1], note 5, page 4).

7.3.2.4 Method of measuring the effective radiated power

This method applies only to equipment without an external 50 Ω antenna connector.

The method of measurement shall be performed according to clause 7.3.2.3, except that the transmitter output shall be connected to the integral antenna and not to an artificial antenna.

7.3.2.5 Method of measuring wideband noise

This method applies to all equipment.

Spurious emissions shall be measured as the mean power level of any signal delivered into a 50 Ω load from either the permanent or temporary antenna connector, as appropriate.

For BS and MS equipment the transmitter shall be modulated with the test signal T1 or T4 (as appropriate, see clause 6.3). If possible, the modulation should be continuous for the duration of the measurement, if this is not possible, the measurements shall be carried out in a period shorter than the duration of the transmitted burst.

Wideband noise level at selected frequency offsets from the on channel shall be measured through the measurement filter, refer to clause 6.6 or if a spectrum analyser is used a power measuring bandwidth of 18 kHz shall be used. The Average power within the bandwidth shall be recorded.

The selected frequency offsets shall cover at least the frequencies indicated in table 9.

If a discrete spurious lies in one of these bands, then the closest discrete spurious free frequency with a larger frequency offset shall be chosen (frequency steps shall be in 25 kHz increments).

The measurement shall be performed at the specified offsets above and below the nominal frequency of the transmitter.

Table 9: Selected frequency offsets for wideband noise measurement

| Bandwidth (kHz) | Frequency offset (kHz) |
|-----------------|------------------------|
| 25 | 112,5 |
| 25 | 262,5 |
| 25 | 512,5 |
| 25 | 2 512,5 |
| 25 | $f_{rb} + 12,5$ |
| 50 | 125 |
| 50 | 275 |
| 50 | 512,5 |
| 50 | $f_{rb} + 12,5$ |
| 100 | 150 |
| 100 | 300 |
| 100 | 550 |
| 100 | 1 012,5 |
| 100 | $f_{rb} + 12,5$ |
| 150 | 175 |
| 150 | 325 |
| 150 | 575 |
| 150 | 1 512,5 |
| 150 | $f_{rb} + 12,5$ |

NOTE: See clause 3.2 for definition of f_{rb} .

7.3.3 Limits

7.3.3.1 Spurious emissions power

The mean power of any spurious emission, occurring at frequencies at a greater frequency offset from the operating frequency of the transmitter than the transition point between the out of band domain and spurious domain as defined in clause 7.3.1 of the present document, shall not exceed the values given in tables 10a and 10b.

For TMO Repeater the Tx Standby function is not applicable.

Table 10a: Conducted emissions

| Frequency range | 9 kHz to 1 GHz | Above 1 GHz to 4 GHz, or above 1 GHz to 12,75 GHz (see clause 7.4.2.2) |
|-----------------|--------------------------|--|
| Tx operating | 0,25 μ W (-36,0 dBm) | 1,0 μ W (-30,0 dBm) |
| Tx Standby | 2,0 nW (-57,0 dBm) | 20,0 nW (-47,0 dBm) |

Table 10b: Radiated emissions

| Frequency range | 30 MHz to 1 GHz | Above 1 GHz to 4 GHz, or above 1 GHz to 12,75 GHz (see clause 7.4.2.3) |
|-----------------|--------------------------|--|
| Tx operating | 0,25 μ W (-36,0 dBm) | 1,0 μ W (-30,0 dBm) |
| Tx Standby | 2,0 nW (-57,0 dBm) | 20,0 nW (-47,0 dBm) |

Table 11a: Reference bandwidths to be used for the measurement of spurious emissions outside the frequency offsets specified for BS and MS equipment in table 11b and for TMO repeater equipment in table 11c

| Frequency range | Reference bandwidth |
|--------------------|---------------------|
| 9 kHz to 150 kHz | 1 kHz |
| 150 kHz to 30 MHz | 10 kHz |
| 30 MHz to 1 GHz | 100 kHz |
| 1 GHz to 12,75 GHz | 1 MHz |

Table 11b: Reference bandwidths to be used close to the wanted emission for BS and MS equipment

| Frequency offset from carrier | Reference bandwidth |
|---|---------------------|
| From transition point to (transition point + 50 kHz) (see note) | 1 kHz |
| (transition point + 50 kHz) to 500 kHz | 10 kHz |

NOTE: The transition point between out of band domain and spurious domain is defined in clause 7.3.1.

Table 11c: Reference bandwidths to be used for TMO repeater

| Frequency offset from carrier | Reference bandwidth |
|---|---------------------|
| 600 kHz to TMO repeater operating band edge | 1 kHz |
| Frequency offset from the TMO repeater operating band | Reference bandwidth |
| > 0 MHz | 10 kHz |
| > 2 MHz | 30 kHz |
| > 5 MHz | 100 kHz |

7.3.3.2 Wideband noise power

7.3.3.2.1 Limit values for MS and BS for phase modulation

The wideband noise levels shall not exceed the limits shown in tables 12a and 12b for the power classes as stated and at the listed offsets from the nominal carrier frequency. The requirements apply symmetrically to both sides of the transmitter band.

Table 12a: Wideband noise limits for frequencies below 700 MHz

| Frequency offset | Maximum wideband noise level | | |
|---------------------|---|--|---|
| | MS power classes 4 or 4L (≤ 1 W) | MS power classes 3 or 3L (1,8 or 3 W) | MS power classes 1 to 2L ($\geq 5,6$ W) |
| 100 kHz to 250 kHz | -75 dBc | -78 dBc | -80 dBc |
| 250 kHz to 500 kHz | -80 dBc | -83 dBc | -85 dBc |
| 500 kHz to f_{rb} | -80 dBc | -85 dBc | -90 dBc |
| > f_{rb} | -100 dBc | -100 dBc | -100 dBc |

NOTE: f_{rb} denotes the frequency offset corresponding to the near edge of the received band or 5 MHz (10 MHz for frequencies above 520 MHz) whichever is greater. All levels are expressed in dBc relative to the actual transmitted power level, and in any case no limit tighter than -55 dBm for offsets $\leq f_{rb}$ or -70 dBm for offsets $> f_{rb}$ shall apply.

Table 12b: Wideband noise limits for frequencies above 700 MHz

| Frequency offset | Maximum wideband noise level | | |
|---------------------|---|---|---|
| | MS power classes 4 or 4L (≤ 1 W) | MS power classes 3L to 2 (1,8 W to 10 W) and BS power classes 4 to 10 (≤ 10 W) | MS power classes 1 and 1L ($\geq 17,5$ W) and BS power classes 1 to 3 ($\geq 17,5$ W) |
| 100 kHz to 250 kHz | -74 dBc | -74 dBc | -80 dBc |
| 250 kHz to 500 kHz | -80 dBc | -80 dBc | -85 dBc |
| 500 kHz to f_{rb} | -80 dBc | -85 dBc | -90 dBc |
| $> f_{rb}$ | -100 dBc | -100 dBc | -100 dBc |

NOTE: f_{rb} denotes the frequency offset corresponding to the near edge of the received band or 10 MHz whichever is greater. All levels are expressed in dBc relative to the actual transmitted power level, and in any case no limit tighter than -55 dBm for offsets $\leq f_{rb}$ or -70 dBm for offsets $> f_{rb}$ shall apply.

These requirements shall be measured under normal conditions.

7.3.3.2.2 Limit values for MS and BS for QAM

The wideband noise levels, measured in clause 7.3.2.5 shall not exceed the limits shown in tables 13a to 13d, for the nominal power levels (P_A , as measured in clause 7.1.2) as stated, and at the listed offsets from the nominal carrier frequency. When applicable, relative measurements (dBc) shall refer to the power level P_A measured in clause 7.2.2. The requirements apply symmetrically to both sides of the transmitter band.

Table 13a: Wideband noise limits 25 kHz QAM

| Frequency offset | Maximum wideband noise level | |
|-----------------------|---|---|
| | MS power classes 3 to 4L (≤ 3 W) | MS power classes 2L to 1 ($\geq 5,6$ W) BS all classes |
| 100 kHz to 250 kHz | -70 dBc | -70 dBc |
| 250 kHz to 500 kHz | -74 dBc | -80 dBc |
| 500 kHz to 2 500 kHz | -80 dBc | -80 dBc |
| 2 500 kHz to f_{rb} | -80 dBc | -90 dBc |
| $> f_{rb}$ | -95 dBc | -95 dBc |

NOTE: f_{rb} denotes the frequency offset corresponding to the near edge of the receive band or 5 MHz (10 MHz for frequencies above 520 MHz) whichever is greater.

Table 13b: Wideband noise limits 50 kHz QAM

| Frequency offset | Maximum wideband noise level for MS and BS | |
|------------------------|--|---|
| | MS power classes 3 to 4L (≤ 3 W) | MS power classes 2L to 1 ($\geq 5,6$ W) BS all classes |
| 112,5 kHz to 262,5 kHz | -68 dBc | -70 dBc |
| 262,5 kHz to 500 kHz | -72 dBc | -75 dBc |
| 500 kHz to f_{rb} | -78 dBc | -80 dBc |
| $> f_{rb}$ | -95 dBc | -95 dBc |

NOTE: f_{rb} denotes the frequency offset corresponding to the near edge of the receive band or 5 MHz (10 MHz for frequencies above 520 MHz) whichever is greater.

Table 13c: Wideband noise limits 100 kHz QAM

| Frequency offset | Maximum wideband noise level for MS and BS | |
|------------------------|--|---|
| | MS power classes 3 to 4L (≤ 3 W) | MS power classes 2L to 1 ($\geq 5,6$ W) BS all classes |
| 137,5 kHz to 287,5 kHz | -60 dBc | -70 dBc |
| 287,5 kHz to 537,5 kHz | -65 dBc | -70 dBc |
| 537,5 kHz to 1 000 kHz | -73 dBc | -75 dBc |
| 1 000 kHz to f_{rb} | -73 dBc | -80 dBc |
| $> f_{rb}$ | -95 dBc | -95 dBc |

NOTE: f_{rb} denotes the frequency offset corresponding to the near edge of the receive band or 5 MHz (10 MHz for frequencies above 520 MHz) whichever is greater.

Table 13d: Wideband noise limits 150 kHz QAM

| Frequency offset | Maximum wideband noise level for MS and BS | |
|------------------------|--|---|
| | MS power classes 3 to 4L (≤ 3 W) | MS power classes 2L to 1 ($\geq 5,6$ W) BS all classes |
| 162,5 kHz to 312,5 kHz | -60 dBc | -60 dBc |
| 312,5 kHz to 562,5 kHz | -63 dBc | -70 dBc |
| 562,5 kHz to 1 500 kHz | -70 dBc | -75 dBc |
| 1 500 kHz – f_{rb} | -70 dBc | -80 dBc |
| $> f_{rb}$ | -95 dBc | -95 dBc |

NOTE: f_{rb} denotes the frequency offset corresponding to the near edge of the receive band or 5 MHz (10 MHz for frequencies above 520 MHz) whichever is greater.

For all levels in tables 13a to 13d, no limit tighter than -55 dBm for offsets $< f_{rb}$ or -70 dBm for offsets $> f_{rb}$ shall apply.

7.3.3.2.3 Limit values for TMO repeater equipment

The wideband noise levels, measured in clause 7.3.2.5 shall not exceed the limits shown in tables 13e to 13h, for the nominal power levels (P_A) as stated, and at the listed offsets from the nominal carrier frequency. When applicable, relative measurements (dBc) shall refer to the power level P_A measured in clause 7.2.2. The requirements apply symmetrically to both sides of the transmitter band.

Table 13e: Wideband noise limits 25 kHz for TMO repeater equipment

| Frequency offset | Maximum wideband noise level |
|--------------------|------------------------------|
| 100 kHz to 250 kHz | -70 dBc |
| 250 kHz to 500 kHz | -80 dBc |
| 500 kHz - f_{rb} | -80 dBc |
| $> f_{rb}$ | -95 dBc |

NOTE: f_{rb} denotes the frequency offset corresponding to the near edge of the receive band or 5 MHz (10 MHz for frequencies above 520 MHz) whichever is greater.

Table 13f: Wideband noise limits 50 kHz for TMO repeater equipment

| Frequency offset | Maximum wideband noise level |
|------------------------|------------------------------|
| 112,5 kHz to 262,5 kHz | -70 dBc |
| 262,5 kHz to 500 kHz | -75 dBc |
| 500 kHz - f_{rb} | -80 dBc |
| $> f_{rb}$ | -95 dBc |

NOTE: f_{rb} denotes the frequency offset corresponding to the near edge of the receive band or 5 MHz (10 MHz for frequencies above 520 MHz) whichever is greater.

Table 13g: Wideband noise limits 100 kHz for TMO repeater equipment

| Frequency offset | Maximum wideband noise level |
|--|------------------------------|
| 137,5 kHz to 287,5 kHz | -70 dBc |
| 287,5 kHz to 537,5 kHz | -70 dBc |
| 537,5 kHz - f_{rb} | -75 dBc |
| $> f_{rb}$ | -95 dBc |
| NOTE: f_{rb} denotes the frequency offset corresponding to the near edge of the receive band or 5 MHz (10 MHz for frequencies above 520 MHz) whichever is greater. | |

Table 13h: Wideband noise limits 150 kHz for TMO repeater equipment

| Frequency offset | Maximum wideband noise level |
|--|------------------------------|
| 162,5 kHz to 312,5 kHz | -60 dBc |
| 312,5 kHz to 562,5 kHz | -70 dBc |
| 562,5 kHz - f_{rb} | -75 dBc |
| $> f_{rb}$ | -95 dBc |
| NOTE: f_{rb} denotes the frequency offset corresponding to the near edge of the receive band or 5 MHz (10 MHz for frequencies above 520 MHz) whichever is greater. | |

For all levels in tables 13e to 13h, no limit tighter than -55 dBm for offsets $< f_{rb}$ or -70 dBm for offsets $> f_{rb}$ shall apply.

7.4 Intermodulation attenuation

7.4.1 Applicability

This requirement applies only to transmitters to be used in base stations or TMO repeater.

7.4.2 Definition

For the purpose of the present document the intermodulation attenuation is a measure of the capability of a transmitter to inhibit the generation of signals in its non-linear elements caused by the presence of the transmitter and an interfering signal entering the transmitter via its antenna at a prescribed level.

7.4.3 Method of measurement

7.4.3.1 Measurement for TMO repeater equipment

Two continuous sinusoidal RF signals shall be fed to the input antenna port of the repeater using a combining device. The frequencies of both RF signals shall be within the repeater's operating band. The spacing between both RF signals shall be the minimum possible spacing supported by the equipment or 200 kHz whichever is greater. The input signals and resulting product shall be within the operating band of the repeater.

The level of both RF input signals shall be increased, until the maximum rated output power per channel is reached.

In case of a repeater only supporting one channel, one RF input signal shall be set to the operating frequency and the other RF input signal at an offset of 100 kHz to either side successively. In this case the input signal at the repeaters operating frequency shall be increased, until the maximum rated output power per channel is reached. The second signal shall be set to the same input level.

The level of the third order intermodulation products shall be measured by means of a selective measurement device presenting to the repeater a load with an impedance of 50 Ω .

The test shall be repeated with both RF input signals increased by 10 dB each.

NOTE: In this case, the automatic gain (level) control may reduce the gain to a value less than maximum gain in order to keep the maximum rated output power per channel, in accordance with the intended operation of the equipment.

An average power measurement shall be performed using a bandwidth of 3 kHz. This test shall be performed in both the uplink and downlink direction at the centre of the repeaters operating band.

The measurement shall be made under normal test conditions (see clause 5.3) on a middle frequency of the operating band of the transmitter (see clause 4.1.2).

7.4.3.2 Measurement for BS

The measurement shall be carried out at one of the middle frequency radio channels of the transmitter (see clause 4.1.2) and at power level P_A under normal test conditions.

The transmitter shall be presented with a 50 Ω load impedance, and shall be coupled to a spectrum analyser via a directional coupler which is arranged to couple the signal output from the transmitter into the spectrum analyser. Attenuators may be used as needed to prevent overloading of the directional coupler and spectrum analyser.

An interfering test signal source shall be arranged to present an unmodulated signal (test signal T3) to the transmitter output connector at a power level 30 dB lower than the transmitter power output. Sufficient attenuators or other means shall be used to ensure that the transmitter and interfering test signal source are both presented with a 50 Ω load impedance throughout the test, and that any intermodulation product formed by any part of the measurement arrangement is sufficiently low as to not influence the output of the test. Isolators may be used if needed to achieve this.

The transmitter under test and the test signal source shall be physically separated in such a way that the measurement is not influenced by direct radiation.

An example measurement arrangement is provided in annex E of the present document.

Prior to carrying out the measurement using the chosen measurement arrangement, which may be according to the example described in annex E of the present document or another arrangement, the power level, P_A , of the transmitter under test shall be measured according to clause 7.1.2 and the value recorded.

To carry out the test using the chosen measurement arrangement, modulation test signal T1 or T4 (as appropriate, see clause 6.3) shall be applied at the transmitter. The transmitter under test shall be set in continuous transmission mode. If this is not possible, the measurement shall be carried out in a period shorter than the duration of the transmitted burst. The power level shall be P_A .

The interfering test signal source shall be unmodulated and the frequency shall be within 400 kHz to 600 kHz above the frequency of the transmitter under test.

The frequency shall be chosen in such a way that the intermodulation components to be measured do not coincide with other spurious components. The power output of the interfering test signal source shall be adjusted to provide the interfering signal to the transmitter output connector at a level of 30 dB below the P_A level recorded above. The value of the intermodulation component shall be obtained by using the spectrum analyser to measure the largest third order intermodulation component. The spectrum analyser bandwidth used for the measurement shall be sufficient to capture the bandwidth of the appropriate T1 or T4 test signal.

This value shall be recorded.

This measurement shall be repeated with the interfering test signal source at a frequency within 400 kHz to 600 kHz below the frequency of the transmitter under test.

The intermodulation attenuation of the equipment under test is calculated using the higher of the two intermodulation component values recorded in above. The intermodulation attenuation ratio is the difference between the intermodulation component and P_A .

7.4.4 Limits

7.4.4.1 Limits for TMO repeater equipment

The level of intermodulation product shall be less than the higher of -60 dBc or -36 dBm.

7.4.4.2 Limits for BS equipment

Two classes of transmitter intermodulation attenuation are defined, the equipment shall fulfil one of the requirements:

- in general the intermodulation attenuation ratio shall be at least 40,0 dB for any intermodulation component;
- for base station equipment to be used in special service conditions (e.g. at sites where more than one transmitter will be in service) or when the regulatory authority makes it a condition of the licence, the intermodulation attenuation ratio shall be at least 70,0 dB for any intermodulation component. In the case where the performance is achieved by additional internal or external isolating devices (such as circulators) these are expected to be available at the time the measurements are made and shall be used for the measurements.

7.5 Adjacent channel transient power measurements

7.5.1 Definition

Transients power is the power falling into adjacent spectrum due to switching the transmitter on and off.

7.5.2 Method of Measurement

Modulation test signal T1 or T4 shall be applied at the transmitter.

The measurement shall be conducted at one of the middle radio frequency channels of the MS or discontinuous mode BS transmit band (see clause 4.1.2). This test shall be carried out at maximum nominal power (P_A , as measured in clause 7.1.2).

For TMO Repeater equipment this test shall be performed in both the uplink and downlink direction at the centre of the repeaters operating band.

The measurement procedure shall be as follows:

- the output of the transmitter shall be connected to the input of the spectrum analyser by a 50 Ω power attenuator to ensure that the impedance presented to the transmitter is 50 Ω and the level at the spectrum analyser input is appropriate. The spectrum analyser shall meet the requirements of annex C and its settings shall be adjusted to:
 - Zero frequency span
 - Resolution bandwidth: 1 kHz
 - Video bandwidth: 10 kHz
 - Peak hold
- the transmitter shall be operated at the maximum rated transmitter power level, under normal test conditions (see clause 5.3);
- by tuning the spectrum analyser centre frequency to the measurement frequencies the power level is measured at the frequencies given in table 14, the measurement being carried out at positive and negative frequency offsets;

Table 14: Frequency displacements

| Channel separation (kHz) | Adjacent Channel Measurement | 1 MHz Measurement |
|-----------------------------|----------------------------------|----------------------------------|
| | Displacement from f_c (kHz) | Displacement from f_c (MHz) |
| 25 | 25 | 1 |
| 50 | 37,5 | 1 |
| 100 | 62,5 | 1 |
| 150 | 87,5 | 1 |

- d) the duration of each measurement (at each frequency) will be such as to cover at least 10 transmissions at f_c , each transmission consisting of a Rx to Tx followed by a Tx to Rx transition;
- e) the spectrum analyser shall be used to record the envelope of the transient power as a function of time. The peak envelope transient power shall be noted for each measurement offset.

7.5.3 Limits

The transient power, in the adjacent channels shall not exceed a value of 45 dB below the P_A of the transmitter for power classes 4 and 4L and shall not exceed a value of 50 dB below the P_A of the transmitter for other power classes, without the need to be below -36,0 dBm.

For measurements at 1 MHz the transient power shall not exceed 45 dB below the P_A of the transmitter, without the need to be below -36,0 dBm.

7.6 Frequency error

7.6.1 Definition

The frequency error of the transmitter is the difference between the measured carrier frequency in the absence of modulation (or with modulation, provided that the presence of modulation allows sufficiently accurate measurement of the carrier frequency), and the nominal frequency of the transmitter.

7.6.2 Method of measurement

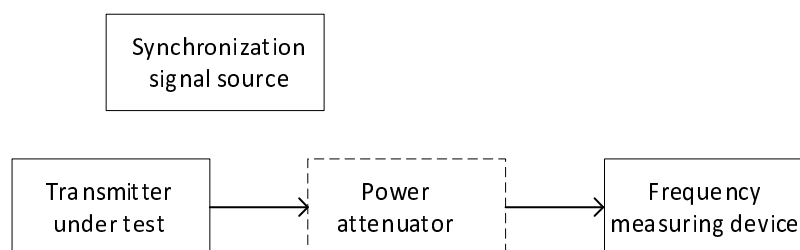

Figure 4: Measurement arrangement

The equipment shall be connected to the frequency measuring device via a power attenuator (if required) as shown in figure 4.

The carrier frequency shall either be measured in the absence of modulation or when modulated by a signal that allows carrier frequency measurement in conjunction with the frequency measuring device used for the measurement. The measurement shall be made under normal test conditions (see clause 5.3) and extreme test conditions (see clauses 5.4.1 and 5.4.2 applied simultaneously). The measurement shall be conducted at one of the middle radio frequency channels of the operating band of the transmitter (see clause 4.1.2).

For equipment that does not permit transmission without synchronizing to a base station the frequency error of the transmitter shall be measured after the equipment has synchronized to a suitable signal, in accordance with the intended operation of the equipment. Such equipment shall prohibit start of transmission if synchronization has not been performed for greater than 4 minutes prior to transmission.

Details of any synchronization signals used and timings of these signals shall be recorded in the test report.

7.6.3 Limits

The frequency error shall not exceed the values given in table 15, under normal and extreme test conditions, or in any intermediate set of conditions. However, for practical reasons the measurement shall be performed only at nominal and extreme test conditions.

Table 15: Frequency error

| Frequency error limit | | | |
|--|---------------------------|----------------------------|---------------------------|
| Above 137 MHz to 520 MHz | | Above 520 MHz to 1 000 MHz | |
| BS | MS | BS | MS |
| ±0,2 ppm | TMO ±100 Hz DMO ±1 kHz | ±0,1 ppm | TMO ±100 Hz DMO ±1 kHz |
| NOTE: For mobile and hand portable equipment that is tested following synchronization (see clause 7.6.2) the frequency error shall at no time exceed the above limits up to 4 minutes after the start of transmission. | | | |

7.7 Out of band gain for TMO repeater equipment

7.7.1 Applicability

This requirement only applies to TMO repeater equipment.

7.7.2 Definition

Out of band gain refers to the net gain of the repeater outside the relevant transmit bands. The test also checks the net gain at harmonic frequencies.

7.7.3 Method of measurement

The TMO repeater shall be set to maximum gain. In case of a channelized repeater, two of the channel selective modules shall be set to the lowermost and the uppermost channels within the repeater's operating band.

A continuous sinusoidal RF signal shall be fed successively at frequency offsets Y from the edges of the relevant MS or BS transmit frequency band into the relevant input port of the repeater. The frequency offsets Y shall have the following values:

- 50 kHz;
- 75 kHz;
- 125 kHz;
- 250 kHz; and
- 500 kHz.

The test shall be repeated with an continuous sinusoidal RF signal successively set to all harmonic frequencies of the repeaters operating band up to 12,75 GHz (i.e. multiples of the centre frequency of the repeaters operating band up to 12,75 GHz).

The power level of the RF input signal shall be at least 5 dB below the power level which would produce, when applied within the operating band, the rated output power, in accordance with the intended operation of the equipment. This is to ensure that the equipment is operating in the linear output range.

Alternatively the measurement of the net gain over the above defined frequency range can be done with a network analyser.

The average output power in each case shall be measured and the net gain shall be recorded.

The measurements shall apply to both the uplink and downlink direction of the repeater.

The measurement shall be made under normal test conditions (see clause 5.3) and extreme test conditions (see clauses 5.4.1 and 5.4.2).

7.7.4 Limits

For TMO repeaters with an operating frequency band of 1 MHz or less the limits detailed in table 16 shall not be exceeded.

Table 16: Maximum gain

| Frequency offset from the - 6 dB point | Maximum gain |
|--|--------------|
| 50 kHz | 63 dB |
| 75 kHz | 50 dB |
| 125 kHz | 30 dB |
| 250 kHz | 20 dB |
| ≥ 500 kHz | 10 dB |

For TMO repeaters with an operating frequency band greater than 1 MHz the limits detailed in table 17 shall not be exceeded.

Table 17: Maximum gain

| Frequency offset from the - 6 dB point | Maximum gain |
|--|--------------|
| 50 kHz | 75 dB |
| 75 kHz | 70 dB |
| 125 kHz | 65 dB |
| 250 kHz | 32 dB |
| ≥ 500 kHz | 28 dB |

The limits in tables 16 and 17 shall be applicable for tests under normal test conditions (see clause 5.3) and extreme test conditions (see clauses 5.4.1 and 5.4.2).

7.8 Modulation accuracy

7.8.1 Applicability

This requirement applies to BS, MS and TMO repeater equipment.

7.8.2 Definition

Modulation accuracy is defined according to ETSI EN 300 392-2 [3], clause 6.4.

NOTE: TETRA modulation [3] is used in this test as a measurement of modulation accuracy.

7.8.3 Method of measurement

The modulation accuracy shall be tested as follows:

- a) the test shall be carried out at maximum nominal power (P_A , as measured in clause 7.1.2) for BS and MS or at maximum nominal gain for TMO repeater equipment;
- b) a T1 or T4 (as appropriate, see clause 6.3) test signal shall be applied to the repeater; MS and BS;

- c) a measurement system shall capture a representation of the transmit burst's vector error at sampling times t_k (symbol by symbol) where t_k is the symbol time corresponding to the k^{th} symbol; for each symbol the sampling system shall compute the vector error $Z'(k) - S(k)$ defined in ETSI EN 300 392-2 [3], clause 6.6.1.2, where $Z'(k)$ is the normalized modulation symbol transmitted by the repeater, BS or MS and $S(k)$ is the modulation symbol which would be transmitted by an ideal repeater, BS or MS; the measurement system shall calculate the RMS vector error for all symbols of the burst as defined in ETSI EN 300 392-2 [3], clause 6.6.1.2; the measuring system shall also calculate the peak vector error magnitude $|Z'(k)-S(k)|$ as defined in ETSI EN 300 392-2 [3], clause 6.6.1.2 for each symbol of the burst and shall calculate the mean residual carrier magnitude $\langle C_0 \rangle$ averaged over all values C_0 of the burst for phase modulation only;
- d) the procedure described in step c) shall be repeated for 200 bursts;
- e) the procedures described in steps a) to b) shall be performed on one each of the lowest, highest and middle radio frequency channels in the transmit band (see clause 4.1.2);
- f) the measurements shall be repeated for both the uplink and downlink directions of the repeater.

7.8.4 Limits

The RMS vector error in any burst shall be less than 0,1 for phase modulation and QAM.

The peak vector error magnitude shall be less than 0,3 for any symbol for phase modulation only.

8 Technical characteristics of the receiver

8.1 Applicability

The receiver requirements in clauses 8.2 to 8.8 require the possibility to demodulate the received signal to make the various measurements however a TMO repeater is, in principle, a bidirectional (uplink and downlink) amplifier, which does not have a receiver in this sense

NOTE: The TMO repeater does not demodulate.

Repeater requirements are defined for both directions of the repeater (uplink and downlink) and hence can be considered as receiver requirements as well. As a result receiver requirements from clauses 8.2 to 8.8 shall not apply to TMO Repeaters.

8.2 Receiver sensitivity

8.2.1 General

The tests shall be carried out at one each of the lowest, highest and middle frequency radio channels of the operating frequency range of the receiver (see clause 4.1.2) and at normal and extreme test conditions.

8.2.2 Definition

The specified sensitivity is the average signal power at the receiver input, produced by a signal at the nominal frequency of the receiver, modulated with the normal test signal (see clause 6.3), which will, without interference, produce after demodulation a data signal with a bit error ratio less than or equal to a specified value.

8.2.3 Method of measurement

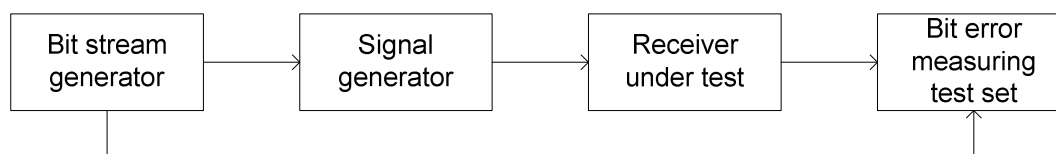

Figure 5: Measurement arrangement

The measurement arrangement is shown in figure 5. The measurement procedure shall be as follows:

- an input signal with a frequency equal to the nominal frequency of the receiver, modulated by the normal test signal T1 or T4 (see clause 6.3), set to the level specified in clause 8.2.4 applicable to the condition under test, shall be applied to the receiver input terminals;
- the bit pattern of the modulating signal shall be compared to the bit pattern obtained from the receiver after demodulation;
- the bit error ratio shall be recorded and compared to the limits specified in clause 8.2.4 for the applicable receiver modulation type and bandwidth;
- the measurement shall be carried out under normal and extreme test conditions (see clauses 5.4.1 and 5.4.2 applied simultaneously).

8.2.4 Limits

8.2.4.1 Limit values for phase modulation

The specified sensitivity for a $\pi/4$ -DQPSK BS receiver under normal and extreme test conditions given in table 18a shall result in a BER not exceeding 4 %.

Table 18a: BS receiver sensitivity for $\pi/4$ -DQPSK

| Test condition | Sensitivity |
|----------------|-------------|
| Normal | -115 dBm |
| Extreme | -109 dBm |

The specified sensitivity for a $\pi/8$ -DQPSK BS receiver under normal and extreme test conditions given in table 18b shall result in a BER not exceeding 3,1 %.

Table 18b: BS receiver sensitivity for $\pi/8$ -D8PSK

| Test condition | Sensitivity |
|----------------|-------------|
| Normal | -110 dBm |
| Extreme | -104 dBm |

The specified sensitivity for a $\pi/4$ -DQPSK MS receiver under normal and extreme test conditions given in table 18c shall result in a BER not exceeding 4,3 %.

Table 18c: MS receiver sensitivity for $\pi/4$ -DQPSK

| Test condition | Sensitivity |
|----------------|-------------|
| Normal | -112 dBm |
| Extreme | -106 dBm |

The specified sensitivity for a $\pi/8$ -DQPSK MS receiver under normal and extreme test conditions given in table 18d shall result in a BER not exceeding 3,1 %.

Table 18d: MS receiver sensitivity $\pi/8$ -D8PSK

| Test condition | Sensitivity |
|----------------|-------------|
| Normal | -107 dBm |
| Extreme | -101 dBm |

8.2.4.2 Limit values for QAM

The specified sensitivity for a MS receiver under normal test conditions given in table 18e shall result in a BER not exceeding 3,7 %. In extreme test conditions, the specified signal level shall be increased by 6 dB.

Table 18e: QAM sensitivity levels for MS

| Channel BW | 4-QAM Sensitivity | 16-QAM Sensitivity | 64-QAM Sensitivity |
|------------|-------------------|--------------------|--------------------|
| 25 kHz | -113 dBm | -106 dBm | -101 dBm |
| 50 kHz | -110 dBm | -103 dBm | -97 dBm |
| 100 kHz | -107 dBm | -100 dBm | -95 dBm |
| 150 kHz | -105 dBm | -99 dBm | -93 dBm |

The specified sensitivity for a BS receiver under normal test conditions given in table 18f shall result in a BER not exceeding 3,7 %. In extreme test conditions, the specified signal level shall be increased by 6 dB.

Table 18f: QAM sensitivity levels for BS

| Channel BW | 4-QAM Sensitivity | 16-QAM Sensitivity | 64-QAM Sensitivity |
|------------|-------------------|--------------------|--------------------|
| 25 kHz | -116 dBm | -109 dBm | -104 dBm |
| 50 kHz | -113 dBm | -106 dBm | -100 dBm |
| 100 kHz | -110 dBm | -103 dBm | -98 dBm |
| 150 kHz | -108 dBm | -102 dBm | -96 dBm |

8.3 Blocking or desensitization

8.3.1 Definition

Blocking is a measure of the capability of the receiver to receive a wanted modulated signal without exceeding a given degradation due to the presence of an unwanted input signal at any frequencies other than those of the spurious responses or the adjacent channels.

8.3.2 Method of measurement

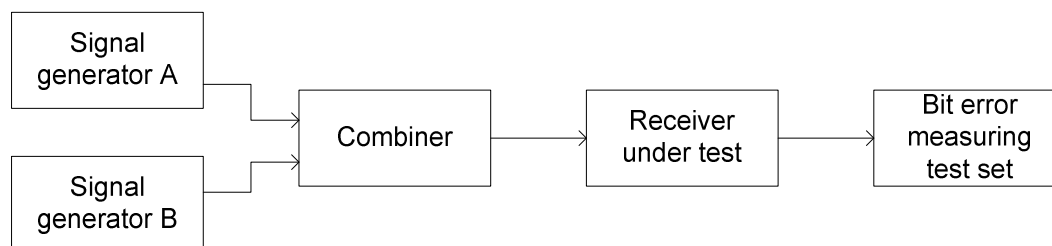

Figure 6: Measurement arrangement

The measurement arrangement is shown in figure 6. Tests shall be carried out at one of the middle frequency radio channels of the operating range of the receiver (see clause 4.1.2). The measurement procedure shall be as follows:

- a) two signal generators, A and B, shall be connected to the receiver via a combining network:
 - the wanted signal, provided by signal generator A, shall be at the nominal frequency of the receiver and shall be modulated by the normal test signal T1 or T4 (see clause 6.3);
 - the unwanted signal, provided by signal generator B, shall be the unmodulated test signal T3 and shall be at a frequency from 1 MHz to 10 MHz away from the nominal frequency of the receiver;

for practical reasons the measurements shall be carried out at frequencies of the unwanted signal at approximately ± 1 MHz, ± 2 MHz, ± 5 MHz and ± 10 MHz, avoiding those frequencies at which spurious responses occur;
- b) the level of the wanted signal from generator A shall be adjusted to the level which is 3 dB above the level of the limit of the specified sensitivity (tables 18a to 18f), at the receiver input terminals;
- c) signal generator B shall be adjusted to a value of -25 dBm;
- d) the bit error ratio shall be recorded and compared to the limits specified in clause 8.3.3 for the applicable receiver modulation type;
- e) the measurement shall be repeated for all the frequencies defined in step a).

8.3.3 Limits

At the specified blocking interferer level of -25 dBm for any frequency within the specified ranges the bit error rate shall not exceed the following values:

- for a $\pi/4$ -DQPSK BS receiver, the BER shall not exceed 4 %;
- for a $\pi/4$ -DQPSK MS receiver, the BER shall not exceed 4,3 %;
- for a $\pi/8$ -DQPSK receiver, the BER shall not exceed 3,1 %;
- for a QAM receiver, the BER shall not exceed 3,7 %.

8.4 Adjacent channel selectivity

8.4.1 Definition

The adjacent channel selectivity is the measure of the capability of the receiver to receive a wanted modulated signal at the nominal frequency without exceeding a given degradation due to the presence of an unwanted signal in 25 kHz bandwidth channels that are adjacent to the channel for which the equipment is intended.

8.4.2 Method of measurement

For equipment that supports adaptive rates, testing is only required at the maximum bit rate that is in accordance with the intended operation of the equipment and is compliant to the present document.

Tests shall be carried out at one of the middle frequency radio channels of the operating range of the receiver (see clause 4.1.2).

The measurement procedure shall be as follows:

- a) two signal generators, A and B, shall be connected to the receiver via a combining network:
 - the wanted signal, provided by signal generator A, shall be at the nominal frequency of the receiver and shall be modulated by the test signal T1 or T4 (see clause 6.3);
 - the unwanted signal, provided by signal generator B, shall be modulated with test signal T2 (using phase modulation in all test cases, see clause 6.3.3) and shall be at the frequency of the 25 kHz bandwidth channel immediately above that of the wanted signal (see table 19);

Table 19: Summary of measurement offset

| | 25 kHz channels | 50 kHz channels | 100 kHz channels | 150 kHz channels |
|---|------------------------|------------------------|-------------------------|-------------------------|
| Nominal Channel Bandwidth | 25 kHz | 50 kHz | 100 kHz | 150 kHz |
| Centre of Adjacent Channel (relative to centre of the nominal channel) | ±25 kHz | ±37,5 kHz | ±62,5 kHz | ±87,5 kHz |

- b) the level of the wanted signal from generator A shall be adjusted to the level which is 3 dB above the relevant limit in tables 18a to 18f, at the receiver input terminals;
- c) signal generator B shall be adjusted to the interferer level for the appropriate receiver modulation type and bandwidth specified in clause 8.4.3;
- d) the bit error ratio shall be recorded and compared to the limits specified in clause 8.4.3 for the applicable receiver modulation type and bandwidth;
- e) the measurement shall be repeated with the unwanted signal at the frequency of the channel below that of the wanted signal;
- f) the measurement shall be repeated under extreme test conditions (see clauses 5.4.1 and 5.4.2 applied simultaneously), with the amplitude of the wanted test signal adjusted to a level 9 dB above the relevant receiver sensitivity level specified for normal conditions in tables 18a to 18f (i.e. to 6 dB above the level of the wanted test signal used in this test in normal conditions).

8.4.3 Limits

The level of the unwanted signal for adjacent channel interference tests are shown in tables 20a and 20b.

Table 20a: Adjacent channel unwanted signal mean power levels for phase modulation

| Channel bandwidth | Interferer level for MS | Interferer level for BS |
|--------------------------|--------------------------------|--------------------------------|
| 25 kHz | -60 dBm | -58 dBm |

For a $\pi/4$ -DQPSK receiver, the BER recorded shall not exceed 4 % for BS or 4,3 % for MS for either adjacent channel.

For a $\pi/8$ -DQPSK receiver, the BER recorded shall not exceed 3,1 % for either adjacent channel.

Table 20b: Adjacent channel unwanted signal mean power levels for QAM

| Channel bandwidth | Interferer level for MS | Interferer level for BS |
|--------------------------|--------------------------------|--------------------------------|
| 25 kHz | -63 dBm | -62 dBm |
| 50 kHz | -65 dBm | -65 dBm |
| 100 kHz | -65 dBm | -65 dBm |
| 150 kHz | -65 dBm | -65 dBm |

For a QAM receiver, the BER recorded shall not exceed 3,7 % for either adjacent channel.

8.5 Spurious radiations

8.5.1 Definition

Spurious radiations from the receiver are components at any frequency, radiated by the equipment and antenna. For transmit only equipment that does not have a receiver this requirement shall apply with the transmitter in an inactive or standby condition.

For equipment with an external 50 Ω antenna connector, the levels of spurious radiations are considered to be:

- a) their power level in a specified load (conducted spurious emission); and
- b) their effective radiated power when radiated by the cabinet and structure of the equipment (cabinet radiation);
or for equipment without an external antenna connector;
- c) their effective radiated power when radiated by the cabinet and the integral antenna.

NOTE: There are only two options allowed - either both a) and b) or only c).

8.5.2 Methods of measurement

8.5.2.1 Method of measuring the power level in a specified load

This method applies only to equipment with an external 50 Ω antenna connector.

Tests shall be carried out at one of the middle frequency radio channels of the operating range of the receiver (see clause 4.1.2).

For equipment that supports adaptive rates, testing is only required at the maximum bit rate that is in accordance with the intended operation of the equipment and is compliant to the present document.

Spurious radiations shall be measured as the power level of any discrete signal at the input terminals of the receiver. The receiver input terminals are connected to a spectrum analyser or selective voltmeter having an input impedance of 50 Ω and the receiver switched on.

If the detecting device is not calibrated in terms of power input, the level of any detected components shall be determined by a substitution method using a signal generator.

The measurements shall extend over the frequency range 9 kHz to 4 GHz for equipment operating on frequencies not exceeding 470 MHz or over the frequency range 9 kHz to 12,75 GHz for equipment operating on frequencies above 470 MHz.

At each frequency at which a spurious component is detected, the power level shall be recorded as the spurious level delivered into the specified load.

8.5.2.2 Method of measuring the effective radiated power

This method applies only to equipment having an external antenna connector.

Tests shall be carried out at one of the middle frequency radio channels of the operating range of the receiver (see clause 4.1.2).

For equipment that supports adaptive rates, testing is only required at the maximum bit rate that is in accordance with the intended operation of the equipment and is compliant to the present document.

The measurement procedure shall be as follows:

- a) a test site which fulfils the requirements for the specified frequency range of this measurement shall be used (see annex B):

the equipment shall be placed at the specified height on a non-conducting support and in the position closest to normal use that is in accordance with the intended operation of the equipment;

- b) the receiver antenna connector shall be connected to an artificial antenna (see clause 6.2):
- the test antenna shall be orientated for vertical polarization and the length of the test antenna shall be chosen to correspond to the frequency of the measuring receiver;
 - the output of the test antenna shall be connected to a measuring receiver;
- c) radiation of any spurious components shall be detected by the test antenna and receiver, over the frequency range 30 MHz to 4 GHz. For equipment operating on frequencies above 470 MHz the measurements shall also be performed over the frequency range 4 GHz to 12,75 GHz if emissions are detected within 10 dB of the specified limit between 1,5 GHz and 4 GHz;
- d) at each frequency at which a component is detected the test antenna shall be raised and lowered through the specified range of height until a maximum signal level is detected by the measuring receiver;
- when a test site according to clause B.1.2 is used, there is no need to vary the height of the antenna;
- e) the receiver shall then be rotated through 360° in the horizontal plane until the maximum signal level detected by the measuring receiver;
- the maximum signal level detected by the measuring receiver shall be noted;
- f) the receiver shall be replaced by a substitution antenna as defined in clause B.1.6;
- the substitution antenna shall be orientated for vertical polarization and the length of the substitution antenna shall be adjusted to correspond to the frequency of the spurious component detected;
- g) the substitution antenna shall be connected to a calibrated signal generator;
- the frequency of the calibrated signal generator shall be set to the frequency of the spurious component detected;
- h) the input attenuator setting of the measuring receiver shall be adjusted in order to increase the sensitivity of the measuring receiver if necessary;
- i) the test antenna shall be raised and lowered through the specified range of height to ensure that the maximum signal is received:
- the input signal to the substitution antenna shall be adjusted to the level that produces a level detected by the measuring receiver, that is equal to the level noted while the spurious component was measured, corrected for the change of input attenuator setting of the measuring receiver;
- the input level of the substitution antenna shall be recorded as a power level, corrected for the change of input attenuator setting of the measuring receiver;
- j) the measurement shall be repeated with the test antenna and the substitution antenna orientated for horizontal polarization;
- k) the measure of the effective radiated power of the spurious components is the larger of the two power levels recorded for each spurious component at the input to the substitution antenna, corrected for the gain of the antenna if necessary.

8.5.3 Limits

The mean power of any spurious radiations shall not exceed the values given in tables 21a and 21b using the appropriate reference bandwidths from table 22.

Table 21a: Conducted components

| Frequency range | 9 kHz to 1 GHz | Above 1 GHz to 4 GHz, or above 1 GHz to 12,75 GHz, (see clause 8.5.2) |
|-----------------|--------------------|---|
| Limit | 2,0 nW (-57,0 dBm) | 20,0 nW (-47,0 dBm) |

Table 21b: Radiated components

| | | |
|------------------------|--------------------|---|
| Frequency range | 30 MHz to 1 GHz | Above 1 GHz to 4 GHz or above 1 GHz to 12,75 GHz (see clause 8.5.2.2) |
| Limit | 2,0 nW (-57,0 dBm) | 20,0 nW (-47,0 dBm) |

Table 22: Reference bandwidths to be used for the measurement of spurious radiations

| Frequency range | Reference bandwidth |
|------------------------|----------------------------|
| 9 kHz to 150 kHz | 1 kHz |
| 150 kHz to 30 MHz | 10 kHz |
| 30 MHz to 1 GHz | 100 kHz |
| 1 GHz to 12,75 GHz | 1 MHz |

8.6 Co-channel rejection

8.6.1 Definition

The co-channel rejection is a measure of the capability of the receiver to receive a wanted modulated signal without exceeding a given degradation due the presence of an unwanted modulated signal, both signals being at the nominal frequency of the receiver.

8.6.2 Method of measurement

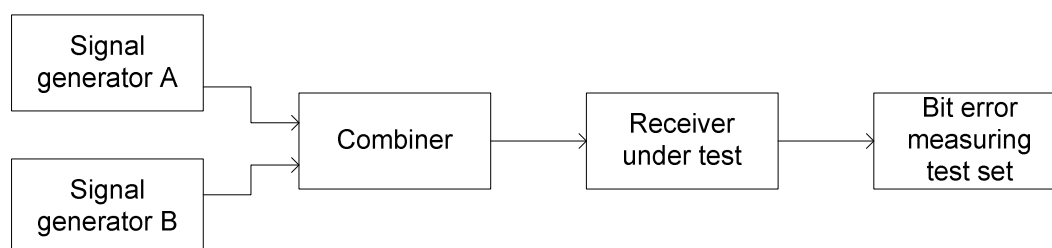
**Figure 7: Measurement arrangement**

Tests shall be carried out at one of the middle frequency radio channels of the operating range of the receiver (see clause 4.1.2) under normal test conditions. The measurement procedure shall be as follows:

- a) two signal generators, A and B, shall be connected to the receiver via a combining network:
 - the wanted signal, provided by signal generator A, shall be at the nominal frequency of the receiver and shall be modulated by the test signal T1 or T4 (see clause 6.3) and set to the level specified in clause 8.6.3 for the appropriate receiver modulation type and bandwidth;
 - the unwanted signal, provided by signal generator B, shall be modulated with signal T2, T2-25, T2-50, T2-100 or T2-150 (see clause 6.3) equivalent to the characteristics of the wanted signal and set to the level specified in clause 8.6.3 for the appropriate receiver modulation type and bandwidth;
 - both input signals shall be at the nominal frequency of the receiver under test;
- b) with both signal generators switched on, the bit error ratio shall be recorded and compared to the limits specified in clause 8.6.3 for the applicable receiver modulation and bandwidth.

NOTE: The value of the co-channel rejection ratio is the ratio of the wanted signal level to the unwanted signal level, and when expressed in dB is generally positive.

8.6.3 Limits

8.6.3.1 Limit values for phase modulation

The measurement conditions, value of the co-channel rejection ratio expressed in dB, and maximum permitted bit error rate at the specified test conditions shall be as shown in table 23.

Table 23: Co-channel measurement conditions and performance for phase modulation

| Modulation type | Wanted signal level | Unwanted signal level | Co-channel ratio | Maximum bit error rate |
|-----------------|---------------------|-----------------------|------------------|------------------------|
| $\pi/4$ -DQPSK | -85 dBm | -95 dBm | 10 dB | 4 % (BS) |
| $\pi/4$ -DQPSK | -85 dBm | -95 dBm | 10 dB | 4,3 % (MS) |
| $\pi/8$ -DQPSK | -74 dBm | -90 dBm | 16 dB | 3,1 % |

8.6.3.2 Limit values for QAM

The measurement conditions, value of the co-channel rejection ratio, expressed in dB, and maximum permitted bit error rate at the specified test conditions shall be as shown in table 24.

Table 24: Co-channel measurement conditions and performance for different channel bandwidths and gross (on-air) bit rates

| Channel BW | Data Rate | Wanted signal level | Unwanted signal level | Co-channel ratio | Maximum bit error rate |
|------------|-----------------------------|---------------------|-----------------------|------------------|------------------------|
| 25 kHz | 38,4 kbit/s or less | -84 dBm | -96 dBm | 12 dB | 3,7 % |
| | 38,5 kbits to 76,8 kbit/s | -70 dBm | -89 dBm | 19 dB | 3,7 % |
| | Greater than 76,8 kbit/s | -60 dBm | -84 dBm | 24 dB | 3,7 % |
| 50 kHz | 76,8 kbit/s or less | -81 dBm | -93 dBm | 12 dB | 3,7 % |
| | 76,9 kbits to 153,6 kbit/s | -67 dBm | -86 dBm | 19 dB | 3,7 % |
| | Greater than 153,6 kbit/s | -56 dBm | -80 dBm | 24 dB | 3,7 % |
| 100 kHz | 153,6 kbit/s or less | -78 dBm | -90 dBm | 12 dB | 3,7 % |
| | 153,7 kbits to 307,2 kbit/s | -64 dBm | -83 dBm | 19 dB | 3,7 % |
| | Greater than 307,2 kbit/s | -54 dBm | -78 dBm | 24 dB | 3,7 % |
| 150 kHz | 230,4 kbit/s or less | -76 dBm | -88 dBm | 12 dB | 3,7 % |
| | 230,5 kbits to 460,8 kbit/s | -63 dBm | -82 dBm | 19 dB | 3,7 % |
| | Greater than 460,8 kbit/s | -52 dBm | -76 dBm | 24 dB | 3,7 % |

8.7 Intermodulation response rejection

8.7.1 Definition

The intermodulation response rejection is a measure of the capability of the receiver to receive a wanted modulated signal, without exceeding a given degradation due to the presence of two or more unwanted signals with a specific frequency relationship to the wanted signal frequency.

8.7.2 Method of measurement

Tests shall be carried out at one of the middle frequency radio channels of the operating range of the receiver (see clause 4.1.2). For equipment that supports adaptive rates, testing is only required at the maximum bit rate that is in accordance with the intended operation of the equipment and is compliant to the present document.

The measurement procedure shall be as follows:

- a) three signal generators, A, B and C, shall be connected to the receiver via a combining network:
 - the wanted signal, provided by signal generator A, shall be at the nominal frequency (f_c) of the receiver and shall be modulated by the test signal T1 or T4 (see clause 6.3);
 - the first unwanted signal, provided by signal generator B shall be the unmodulated test signal T3 and adjusted to a frequency above the nominal frequency of the receiver (f_1);
 - the second unwanted signal, provided by signal generator C, shall be modulated with test signal T2 (using phase modulation in all test cases, see clause 6.3.3) and adjusted above the nominal frequency of the receiver (f_2);
 - the frequencies f_c , f_1 and f_2 shall have the following relationship $f_c = 2f_1 - f_2$ and $|f_2 - f_1| = f_x$. Where f_x is defined in table 25;

Table 25: f_x definition

| Channel bandwidth | f_x |
|-------------------|-----------|
| 25 kHz | 200 kHz |
| 50 kHz | 400 kHz |
| 100 kHz | 800 kHz |
| 150 kHz | 1 200 kHz |

- b) the level of the wanted signal from generator A shall be adjusted to the level which is 3 dB above the relevant receiver sensitivity specification in tables 18a to 18f, at the receiver input terminals;
- c) signal generators B and C shall be adjusted to a level of -47 dBm;
- d) the bit error ratio shall be recorded and compared to the limits specified in clause 8.7.3 for the applicable receiver modulation type;
- e) the measurement shall be repeated with the unwanted signal generators B and C at the frequencies below that of the wanted signal while still meeting the relationship $f_c = 2f_1 - f_2$ and $|f_2 - f_1| = f_x$.

8.7.3 Limit

At the specified intermodulation interferer level of -47 dBm, the bit error rate shall not exceed the following values:

- for a $\pi/4$ -DQPSK BS receiver, the BER shall not exceed 4 %;
- for a $\pi/4$ -DQPSK MS receiver, the BER shall not exceed 4,3 %;
- for a $\pi/8$ -DQPSK receiver, the BER shall not exceed 3,9 %;
- for a QAM receiver, the BER shall not exceed 3,7 %.

8.8 Spurious response rejection

8.8.1 Definition

Spurious response rejection is a measure of the capability of a receiver to receive a wanted modulated signal without exceeding a given degradation due to the presence of an unwanted unmodulated signal at any other frequency at which a response is obtained, i.e. for which the blocking limit is not met.

8.8.2 Method of measurement

Tests shall be carried out at one of the middle frequency radio channels of the operating range of the receiver (see clause 4.1.2) under normal test conditions:

- a) The same test configuration and conditions as in clause 8.3 for blocking or desensitization are applied with exceptions. The frequency and level of the wanted signal provided by signal generator A providing test signal T1 or T4 shall be according to clause 8.3. The frequency of the interfering signal provided by signal generator B providing test signal T3 is set to the frequencies as defined in clause D.2, and the power level of the interfering signal is set to the level specified in ETSI EN 300 392-2 [3], tables 6.21 to 6.25: Blocking levels of the receiver, according to receiver modulation type and bandwidth. For each interfering frequency the error rate shall be measured. An interfering frequency where the blocking bit error rate limit in clause 8.8.3 is not fulfilled is defined as a spurious response frequency.
- b) For each spurious response frequency the error rate shall be measured with a power level of the interfering signal of -45 dBm.
- c) For each of the spurious response frequencies found in step a) the frequency and bit error rate shall be indicated.

8.8.3 Limits

For each spurious response frequency recorded in step a) of clause 8.8.2, the bit error rate recorded in step b) of clause 8.8.2 at the specified interference level of -45 dBm shall be as follows:

- for a $\pi/4$ -DQPSK BS receiver, the BER recorded shall not exceed 4 %;
- for a $\pi/4$ -DQPSK MS receiver, the BER shall not exceed 4,3 %;
- for a $\pi/8$ -DQPSK receiver, the BER recorded shall not exceed 3,1 %;
- for a QAM receiver, the BER shall not exceed 3,7 %.

The number of spurious responses where the blocking requirements as defined in step a) are not met shall not exceed $0,05 \times$ (number of frequency channels in the limited frequency range, as defined in clause D.2).

Annex A (informative): Relationship between the present document and the essential requirements of Directive 2014/53/EU

The present document has been prepared under the Commission's standardisation request C(2015) 5376 final [i.6] to provide one voluntary means of conforming to the essential requirements of Directive 2014/53/EU on the harmonisation of the laws of the Member States relating to the making available on the market of radio equipment and repealing Directive 1999/5/EC [i.2].

Once the present document is cited in the Official Journal of the European Union under that Directive, compliance with the normative clauses of the present document given in table A.1 confers, within the limits of the scope of the present document, a presumption of conformity with the corresponding essential requirements of that Directive and associated EFTA regulations.

Table A.1: Relationship between the present document and the essential requirements of Directive 2014/53/EU

| Harmonised Standard ETSI EN 303 758 | | | | | |
|-------------------------------------|---|-------------------------------------|-----------------------------------|----------------------------|--|
| Requirement | | | | Requirement Conditionality | |
| No | Description | Essential requirements of Directive | Clause(s) of the present document | U/C | Condition |
| 1 | Transmitter frequency error | 3.2 | 7.6 | U | |
| 2 | Transmitter output power (conducted) | 3.2 | 7.1 | U | |
| 3 | Transmitter adjacent and alternate channel power | 3.2 | 7.2 | U | |
| 4 | Transmitter unwanted emissions in the spurious domain | 3.2 | 7.3 | U | |
| 5 | Transmitter intermodulation attenuation | 3.2 | 7.4 | C | Applies only to base station and TMO Repeater equipment. |
| 6 | Transmitter adjacent channel transient power measurements | 3.2 | 7.5 | C | Does not apply to continuous mode base station. |
| 7 | Out of band gain for TMO repeater equipment | 3.2 | 7.7 | C | Applies only to TMO Repeater equipment. |
| 8 | Modulation accuracy | 3.2 | 7.8 | U | |
| 9 | Receiver spurious radiations | 3.2 | 8.5 | C | Does not apply to TMO Repeater. |
| 10 | Receiver sensitivity | 3.2 | 8.2 | C | Does not apply to TMO Repeater. |
| 11 | Receiver co-channel rejection | 3.2 | 8.6 | C | Does not apply to TMO Repeater. |
| 12 | Receiver adjacent channel selectivity | 3.2 | 8.4 | C | Does not apply to TMO Repeater. |
| 13 | Receiver intermodulation response rejection | 3.2 | 8.7 | C | Does not apply to TMO Repeater. |
| 14 | Receiver blocking or desensitization | 3.2 | 8.3 | C | Does not apply to TMO Repeater. |
| 15 | Receiver spurious response rejection | 3.2 | 8.8 | C | Does not apply to TMO Repeater. |

Key to columns:

Requirement:

No A unique identifier for one row of the table which may be used to identify a requirement.

Description A textual reference to the requirement.

Essential requirements of Directive

Identification of article(s) defining the requirement in the Directive.

Clause(s) of the present document

Identification of clause(s) defining the requirement in the present document unless another document is referenced explicitly.

Requirement Conditionality:

| | |
|------------------|---|
| U/C | Indicates whether the requirement is unconditionally applicable (U) or is conditional upon the manufacturer's claimed functionality of the equipment (C). |
| Condition | Explains the conditions when the requirement is or is not applicable for a requirement which is classified "conditional". |

Presumption of conformity stays valid only as long as a reference to the present document is maintained in the list published in the Official Journal of the European Union. Users of the present document should consult frequently the latest list published in the Official Journal of the European Union.

Other Union legislation may be applicable to the product(s) falling within the scope of the present document.

Annex B (normative): Radiated measurement

B.1 Test sites and general arrangements for measurements involving the use of radiated fields

B.1.1 General

This annex introduces three most commonly available test sites, an Anechoic Chamber, an Anechoic Chamber with a ground plane and an Open Area Test Site (OATS), which may be used for radiated tests. These test sites are generally referred to as free field test sites. Both absolute and relative measurements can be performed in these sites. Where absolute measurements are to be carried out, the chamber should be verified. A detailed verification procedure is described in ETSI TR 102 273 [i.8] relevant parts 2, 3 and 4.

NOTE: To ensure reproducibility and traceability of radiated measurements only these test sites should be used in measurements in accordance with the present document.

B.1.2 Anechoic chamber

An anechoic chamber is an enclosure, usually shielded, whose internal walls, floor and ceiling are covered with radio absorbing material, normally of the pyramidal urethane foam type. The chamber usually contains an antenna support at one end and a turntable at the other. A typical anechoic chamber is shown in figure B.1.

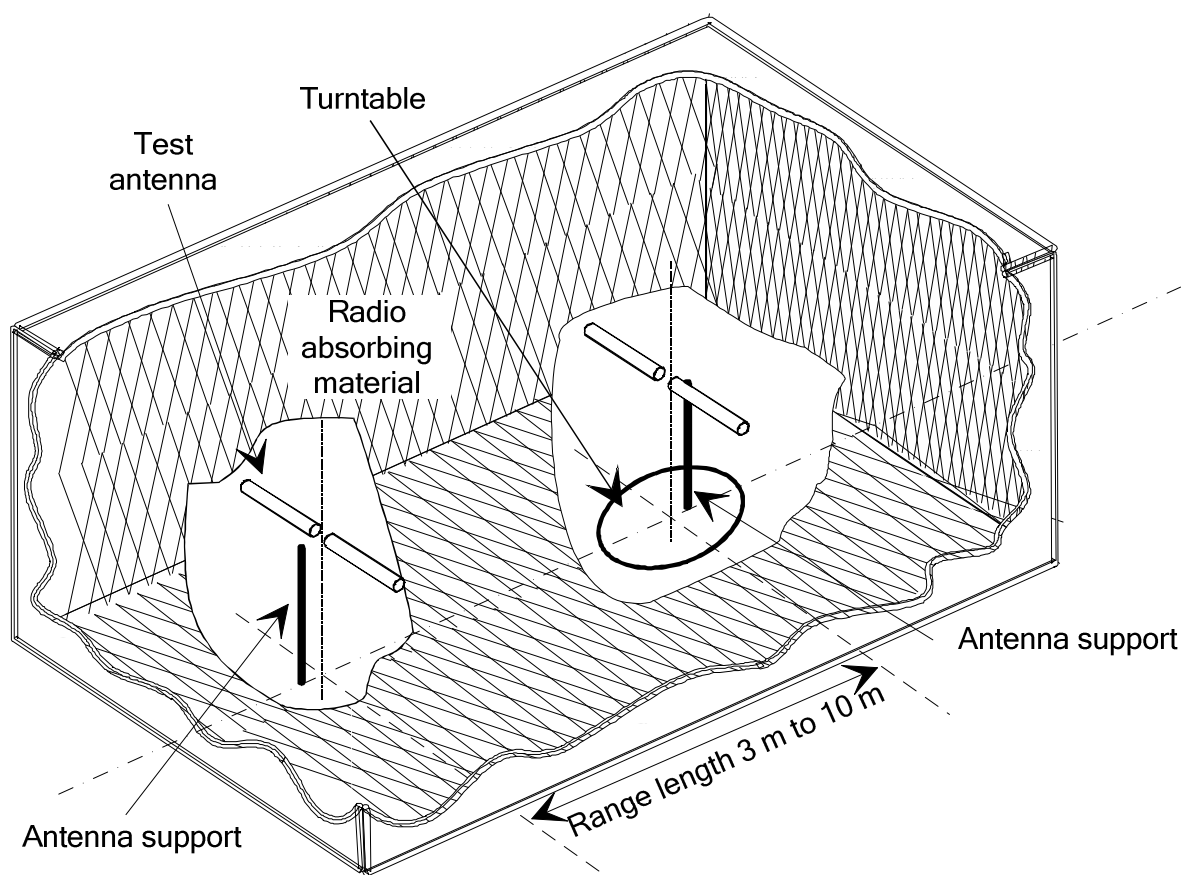

Figure B.1: A typical anechoic chamber

The chamber shielding and radio absorbing material work together to provide a controlled environment for testing purposes. This type of test chamber attempts to simulate free space conditions.

The shielding provides a test space, with reduced levels of interference from ambient signals and other outside effects, whilst the radio absorbing material minimizes unwanted reflections from the walls and ceiling which can influence the measurements. In practice it is relatively easy for shielding to provide high levels (80 dB to 140 dB) of ambient interference rejection, normally making ambient interference negligible.

A turntable is capable of rotation through 360° in the horizontal plane and it is used to support the test sample (EUT) at a suitable height (e.g. 1 m) above the ground plane. The chamber shall be large enough to allow the measuring distance of at least 3 m or $2(d_1 + d_2)^2/\lambda$ (m), whichever is greater (see clause B.2.5). The distance used in actual measurements shall be recorded with the test results.

The anechoic chamber generally has several advantages over other test facilities. There is minimal ambient interference, minimal floor, ceiling and wall reflections and it is independent of the weather. It does however have some disadvantages which include limited measuring distance and limited lower frequency usage due to the size of the pyramidal absorbers. To improve low frequency performance, a combination structure of ferrite tiles and urethane foam absorbers is commonly used.

All types of emission, sensitivity and immunity testing can be carried out within an Anechoic Chamber without limitation.

B.1.3 Anechoic chamber with a conductive ground plane

An anechoic chamber with a conductive ground plane is an enclosure, usually shielded, whose internal walls and ceiling are covered with radio absorbing material, normally of the pyramidal urethane foam type. The floor, which is metallic, is not covered and forms the ground plane. The chamber usually contains an antenna mast at one end and a turntable at the other. A typical anechoic chamber with a conductive ground plane is shown in figure B.2.

This type of test chamber attempts to simulate an ideal Open Area Test Site whose primary characteristic is a perfectly conducting ground plane of infinite extent.

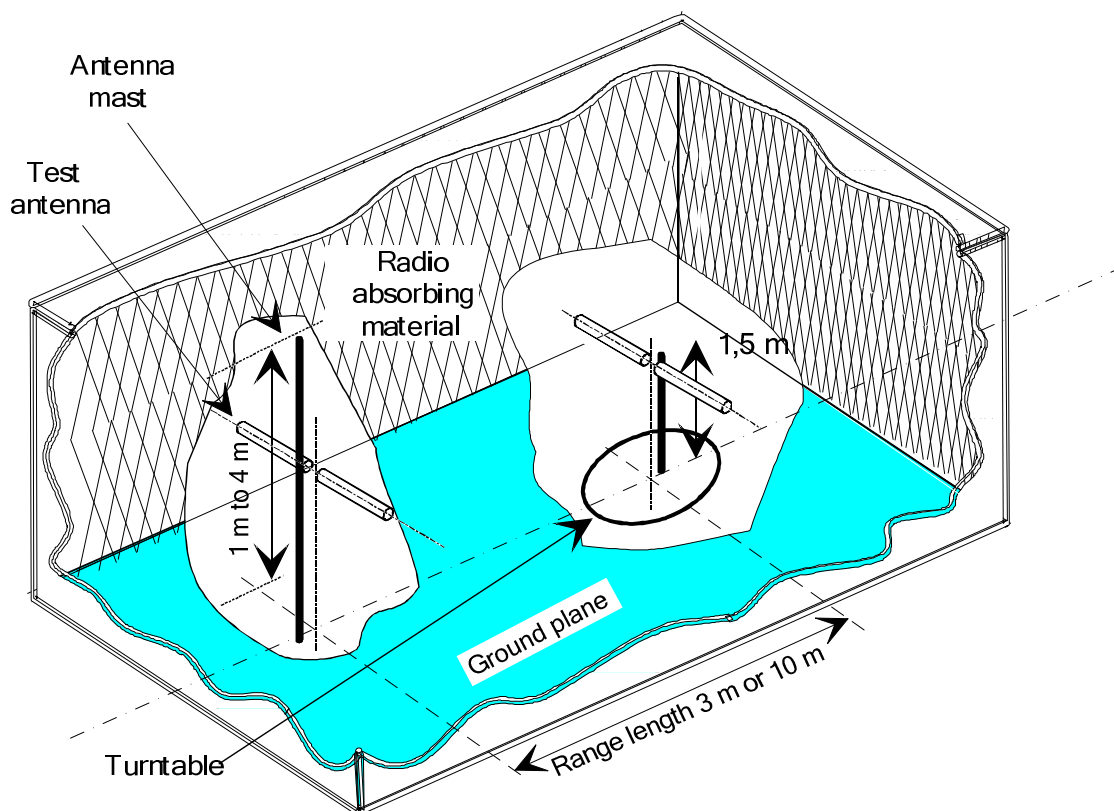

Figure B.2: A typical anechoic chamber with a conductive ground plane

In this facility the ground plane creates the wanted reflection path, such that the signal received by the receiving antenna is the sum of the signals from both the direct and reflected transmission paths. This creates a unique received signal level for each height of the transmitting antenna (or EUT) and the receiving antenna above the ground plane.

The antenna mast provides a variable height facility (from 1 to 4 metres) so that the position of the test antenna can be optimized for maximum coupled signal between antennas or between a EUT and the test antenna.

A turntable is capable of rotation through 360° in the horizontal plane and it is used to support the test sample (EUT) at a specified height, usually 1,5 metres above the ground plane. The chamber shall be large enough to allow the measuring distance of at least 3 m or $2(d_1 + d_2)/\lambda$ (m), whichever is greater (see clause B.2.5). The distance used in actual measurements shall be recorded with the test results.

Emission testing involves firstly "peaking" the field strength from the EUT by raising and lowering the receiving antenna on the mast (to obtain the maximum constructive interference of the direct and reflected signals from the EUT) and then rotating the turntable for a "peak" in the azimuth plane. At this height of the test antenna on the mast, the amplitude of the received signal is noted. Secondly the EUT is replaced by a substitution antenna (positioned at the EUT's phase or volume centre) which is connected to a signal generator. The signal is again "peaked" and the signal generator output adjusted until the level, noted in stage one, is again measured on the receiving device.

Receiver sensitivity tests over a ground plane also involve "peaking" the field strength by raising and lowering the test antenna on the mast to obtain the maximum constructive interference of the direct and reflected signals, this time using a measuring antenna which has been positioned where the phase or volume centre of the EUT will be during testing. A transform factor is derived. The test antenna remains at the same height for stage two, during which the measuring antenna is replaced by the EUT. The amplitude of the transmitted signal is reduced to determine the field strength level at which a specified response is obtained from the EUT.

B.1.4 Open Area Test Site (OATS)

An Open Area Test Site comprises a turntable at one end and an antenna mast of variable height at the other end above a ground plane which, in the ideal case, is perfectly conducting and of infinite extent. In practice, while good conductivity can be achieved, the ground plane size has to be limited. A typical Open Area Test Site is shown in figure B.3.

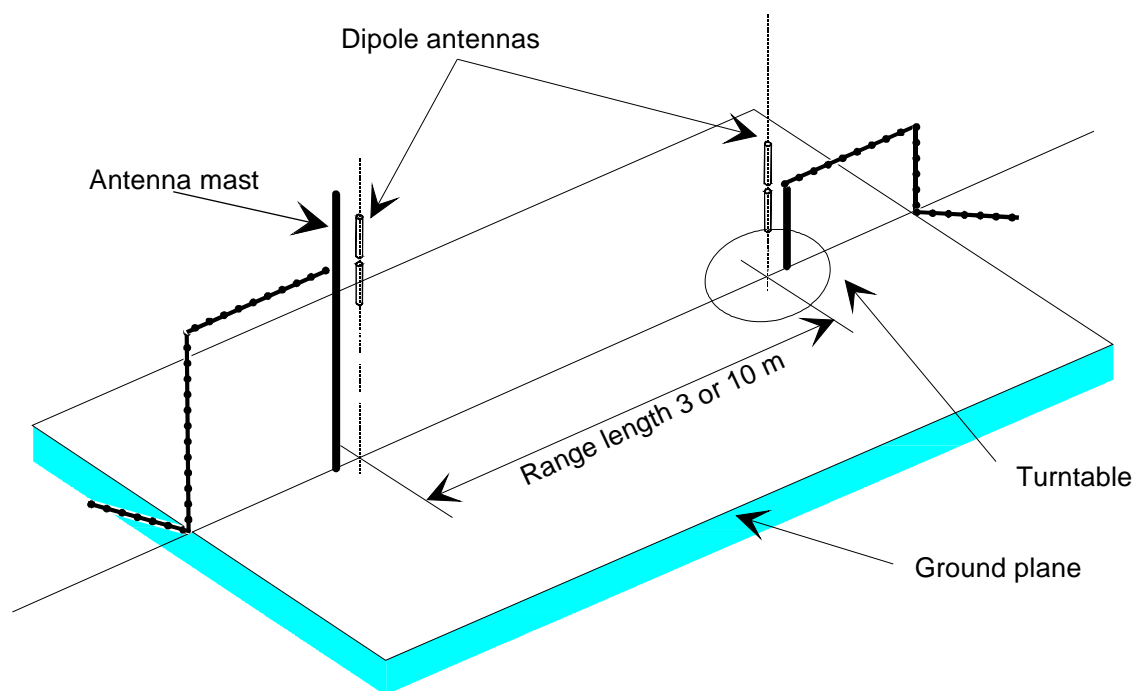

Figure B.3: A typical Open Area Test Site

The ground plane creates a wanted reflection path, such that the signal received by the receiving antenna is the sum of the signals received from the direct and reflected transmission paths. The phasing of these two signals creates a unique received level for each height of the transmitting antenna (or EUT) and the receiving antenna above the ground plane.

Site qualification concerning antenna positions, turntable, measurement distance and other arrangements are same as for anechoic chamber with a ground plane. In radiated measurements an OATS is also used by the same way as anechoic chamber with a ground plane.

Typical measuring arrangement common for ground plane test sites is presented in figure B.4.

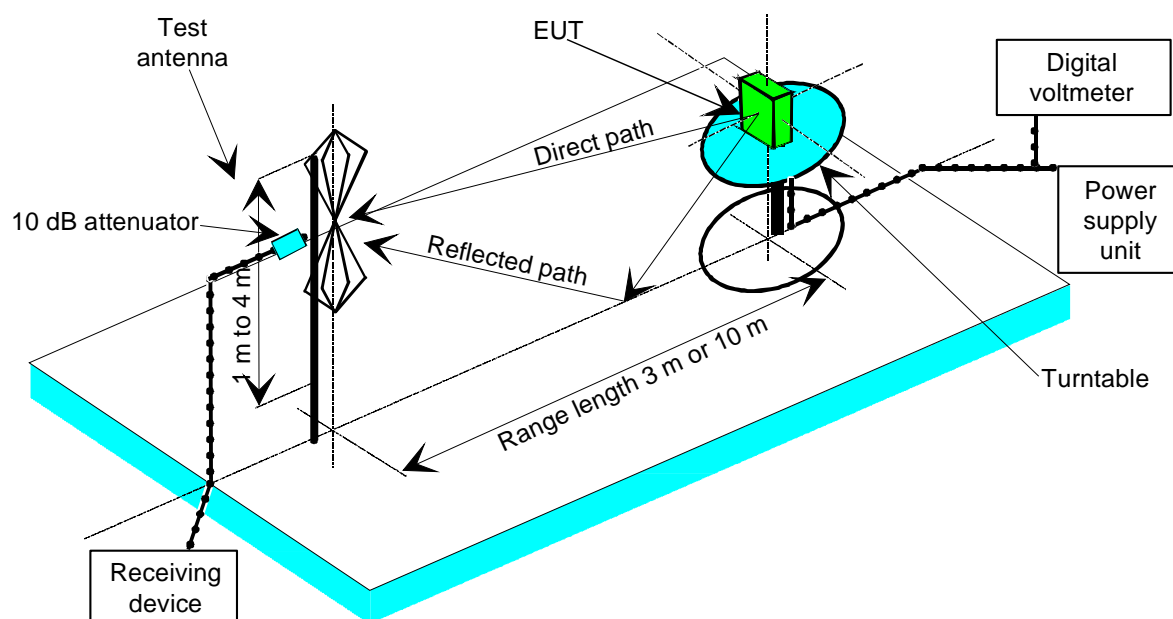

Figure B.4: Measuring arrangement on ground plane test site (OATS set-up for spurious emission testing)

B.1.5 Test antenna

A test antenna is always used in radiated test methods. In emission tests (i.e. frequency error, effective radiated power, spurious emissions and adjacent channel power) the test antenna is used to detect the field from the EUT in one stage of the measurement and from the substitution antenna in the other stage. When the test site is used for the measurement of receiver characteristics (i.e. sensitivity and various immunity parameters) the antenna is used as the transmitting device.

The test antenna should be mounted on a support capable of allowing the antenna to be used in either horizontal or vertical polarization which, on ground plane sites (i.e. Anechoic Chambers with ground planes and Open Area Test Sites), should additionally allow the height of its centre above the ground to be varied over the specified range (usually 1 to 4 metres).

In the frequency band 30 MHz to 1 000 MHz, dipole antennas (constructed in accordance with IEEE/ANSI C63.5 [2]) are generally recommended. For frequencies of 80 MHz and above, the dipoles should have their arm lengths set for resonance at the frequency of test. Below 80 MHz, shortened arm lengths are recommended. For spurious emission testing, however, a combination of biconical antennas (commonly termed "bicones") and log periodic dipole array antennas (commonly termed "log periodics") could be used to cover the entire 30 MHz to 1 000 MHz band. Above 1 000 MHz, waveguide horns are recommended although, again, log periodics could be used.

NOTE: The gain of a horn antenna is generally expressed relative to an isotropic radiator.

B.1.6 Substitution antenna

The substitution antenna is used to replace the EUT for tests in which a transmitting parameter (i.e. frequency error, effective radiated power, spurious emissions and adjacent channel power) is being measured. For measurements in the frequency band 30 MHz to 1 000 MHz, the substitution antenna should be a dipole antenna (constructed in accordance with IEEE/ANSI C63.5 [2]). For frequencies of 80 MHz and above, the dipoles should have their arm lengths set for resonance at the frequency of test. Below 80 MHz, shortened arm lengths are recommended. For measurements above 1 000 MHz, a waveguide horn is recommended. The centre of this antenna should coincide with either the phase centre or volume centre.

B.1.7 Measuring antenna

The measuring antenna is used in tests on a EUT in which a receiving parameter (i.e. sensitivity and various immunity tests) is being measured. Its purpose is to enable a measurement of the electric field strength in the vicinity of the EUT. For measurements in the frequency band 30 MHz to 1 000 MHz, the measuring antenna should be a dipole antenna (constructed in accordance with IEEE/ANSI C63.5 [2], clause 6.3). For frequencies of 80 MHz and above, the dipoles should have their arm lengths set for resonance at the frequency of test. Below 80 MHz, shortened arm lengths are recommended. The centre of this antenna should coincide with either the phase centre or volume centre (as specified in the test method) of the EUT.

B.2 Guidance on the use of radiation test sites

B.2.1 General

This clause details procedures, test equipment arrangements and verification that should be carried out before any of the radiated test are undertaken. These schemes are common to all types of test sites described in annex B.

B.2.2 Verification of the test site

No test should be carried out on a test site which does not possess a valid certificate of verification. The verification procedures for the different types of test sites described in annex B (i.e. Anechoic Chamber, Anechoic Chamber with a ground plane and Open Area Test Site) are given in ETSI TR 102 273 [i.8] parts 2, 3 and 4, respectively.

B.2.3 Preparation of the EUT

Information should be supplied about the EUT covering the operating frequency, polarization, supply voltage(s) and the reference face. Additional information, specific to the type of EUT should include, where relevant, carrier power, channel separation, whether different operating modes are available (e.g. high and low power modes) and if operation is continuous or is subject to a maximum test duty cycle (e.g. 1 minute on, 4 minutes off).

Where necessary, a mounting bracket of minimal size should be available for mounting the EUT on the turntable. This bracket should be made from low conductivity, low relative dielectric constant (i.e. less than 1,5) material(s) such as expanded polystyrene, balsa wood, etc.

B.2.4 Power supplies to the EUT

All tests should be performed using power supplies wherever possible, including tests on EUT designed for battery-only use. In all cases, power leads should be connected to the EUT's supply terminals (and monitored with a digital voltmeter) but the battery should remain present, electrically isolated from the rest of the equipment, possibly by putting tape over its contacts.

The presence of these power cables can, however, affect the measured performance of the EUT. For this reason, they should be made to be "transparent" as far as the testing is concerned. This can be achieved by routing them away from the EUT and down to the either the screen, ground plane or facility wall (as appropriate) by the shortest possible paths. Precautions should be taken to minimize pick-up on these leads (e.g. the leads could be twisted together, loaded with ferrite beads at 0,15 metre spacing or otherwise loaded).

B.2.5 Range length

The range length for all these types of test facility should be adequate to allow for testing in the far-field of the EUT i.e. it should be equal to or exceed:

$$\frac{2(d_1 + d_2)^2}{\lambda}$$

Where:

- d_1 is the largest dimension of the EUT/dipole after substitution (m);
- d_2 is the largest dimension of the test antenna (m);
- λ is the test frequency wavelength (m).

It should be noted that in the substitution part of this measurement, where both test and substitution antennas are half wavelength dipoles, this minimum range length for far-field testing would be:

$$2\lambda$$

It should be noted in test reports when either of these conditions is not met so that the additional measurement uncertainty can be incorporated into the results.

NOTE 1: For the fully anechoic chamber, no part of the volume of the EUT should, at any angle of rotation of the turntable, fall outside the "quiet zone" of the chamber at the nominal frequency of the test.

NOTE 2: The "quiet zone" is a volume within the Anechoic Chamber (without a ground plane) in which a specified performance has either been proven by test, or is guaranteed by the designer/manufacturer. The specified performance is usually the reflectivity of the absorbing panels or a directly related parameter (e.g. signal uniformity in amplitude and phase). It should be noted however that the defining levels of the quiet zone tend to vary.

NOTE 3: For the anechoic chamber with a ground plane, a full height scanning capability, i.e. 1 to 4 metres, should be available for which no part of the test antenna should come within 1 metre of the absorbing panels. For both types of Anechoic Chamber, the reflectivity of the absorbing panels should not be worse than -5 dB.

NOTE 4: For both the anechoic chamber with a ground plane and the Open Area Test Site, no part of any antenna should come within 0,25 metre of the ground plane at any time throughout the tests. Where any of these conditions cannot be met, measurements should not be carried out.

B.2.6 Site preparation

The cables for both ends of the test site should be routed horizontally away from the testing area for a minimum of 2 metres (unless, in the case both types of anechoic chamber, a back wall is reached) and then allowed to drop vertically and out through either the ground plane or screen (as appropriate) to the test equipment. Precautions should be taken to minimize pick up on these leads (e.g. dressing with ferrite beads, or other loading). The cables, their routing and dressing should be identical to the verification set-up.

NOTE: For ground reflection test sites (i.e. anechoic chambers with ground planes and Open Area Test Sites) which incorporate a cable drum with the antenna mast, the 2 metres requirement may be impossible to comply with.

Calibration data for all items of test equipment should be available and valid. For test, substitution and measuring antennas, the data should include gain relative to an isotropic radiator (or antenna factor) for the frequency of test. Also, the VSWR of the substitution and measuring antennas should be known.

The calibration data on all cables and attenuators should include insertion loss and VSWR throughout the entire frequency range of the tests. All VSWR and insertion loss figures should be recorded in the log book results sheet for the specific test.

Where correction factors/tables are required, these should be immediately available.

For all items of test equipment, the maximum errors they exhibit should be known along with the distribution of the error e.g.:

- cable loss: $\pm 0,5$ dB with a rectangular distribution;
- measuring receiver: 1,0 dB (standard deviation) signal level accuracy with a Gaussian error distribution.

At the start of measurements, system checks should be made on the items of test equipment used on the test site.

B.3 Coupling of signals

B.3.1 General

The presence of leads in the radiated field may cause a disturbance of that field and lead to additional measurement uncertainty. These disturbances can be minimized by using suitable coupling methods, offering signal isolation and minimum field disturbance (e.g. optical and acoustic coupling).

B.3.2 Data signals

Isolation can be provided by the use of optical, ultrasonic or infra-red means. Field disturbance can be minimized by using a suitable fibre optic connection. ultrasonic or infra-red radiated connections require suitable measures for the minimization of ambient noise.

Annex C (normative): Spectrum analyser specification

Methods of measurement in clauses 7.2 to 7.5 refer to the use of a spectrum analyser. The characteristics of the spectrum analyser shall meet at least the following requirements:

- the reading accuracy of the frequency marker shall be within ± 100 Hz;
- the accuracy of relative amplitude measurements shall be within $\pm 3,5$ dB;
- detector modes supported: Positive Peak and rms;

and if used for measurement in clause 7.3:

- frequency range: 9 kHz to 4 GHz (9 kHz to 12,75 GHz for equipment capable of operating at frequencies greater than 470 MHz).

It shall be possible to adjust the spectrum analyser to allow the separation on its screen of two equal amplitude components with a frequency difference of 500 Hz.

For statistically distributed modulations, the spectrum analyser and the integrating device (when appropriate) needs to allow determination of the power spectral density (energy per time and bandwidth), which has to be integrated over the bandwidth in question.

The spectrum analyser should have a dynamic range greater than 90 dB and the average phase noise in the adjacent and alternate channels shall be such that measurement of adjacent and alternate channel power (see clause 7.3) is not limited by phase noise. In order to confirm this the selected measurement technique for clause 7.3.2 shall be used to measure the adjacent and alternate channel power with a CW signal source with average phase noise of less than -120 dBc/Hz at 25 kHz offset and -125 dBc/Hz at 50 kHz. The maximum adjacent channel power observed with these conditions shall not exceed -65 dBc, and the maximum alternate channel power measured with these conditions shall not exceed -70 dBc.

Annex D (normative): TETRA receiver testing

D.1 Test signal T1/T4, content of BSCH, BSCH-Q/T, BNCH/T and BNCH-Q/T

Tables D.1, D.2, D.3 and D.4 define the information content of the BSCH, BNCH/T, BSCH-Q/T and BNCH-Q/T bursts, used during testing as follows:

- BSCH and BNCH/T are sent by the test equipment using $\pi/4$ -DQPSK modulation, when MS performance is tested on a phase modulated channel.
- BSCH and BNCH/T are sent by the test equipment using $\pi/4$ -DQPSK modulation, when CA MS performance is tested on a QAM channel.
- BSCH and BNCH/T are sent by the BS using $\pi/4$ -DQPSK modulation, when BS performance is tested on a phase modulated channel.
- BSCH-Q/T is sent by the test equipment using QAM, when DA MS performance is tested on a QAM channel.
- BNCH-Q/T is sent by the BS using QAM, when BS performance is tested on a QAM channel.

Table D.1: Test signal T1/T4 content of the BSCH

| Information element | Size (bits) | Values | Meaning |
|--------------------------|-------------|---------------------------------|--|
| System code | 4 | 0xxx ₂ | V+D reserved |
| | | 1xxx ₂ | Reserved |
| Base Colour Code | 6 | xxxxxx ₂ | Any BCC value 1 to 63 |
| Timeslot number | 2 | 00 ₂ | Timeslot 1, used when testing MS performance on a phase modulated channel |
| | | 01 ₂ | Reserved |
| | | 10 ₂ | Timeslot 3, used when testing CA MS performance on a QAM modulated channel |
| | | 11 ₂ | Reserved |
| Frame number | 5 | 10010 ₂ | Frame 18 |
| Multiframe number | 6 | 111100 ₂ | Multiframe 60 |
| Sharing mode | 2 | 00 ₂ | Continuous transmission |
| TS reserved frames | 3 | xxx ₂ | Do not care |
| U-plane DTX | 1 | x ₂ | Do not care |
| Frame 18 extension | 1 | x ₂ | Do not care |
| Reserved | 1 | x ₂ | Do not care |
| Mobile Country Code | 10 | xxxxxxxxx ₂ | Any MCC value 0 to 1 023 |
| Mobile Network Code | 14 | xxxxxxx xxxxxxx ₂ | Any MNC value 0 to 16 383 |
| Neighbour Cell Broadcast | 2 | 00 ₂ | Do not care |
| Cell Service Level | 2 | 00 ₂ | Do not care |
| Late Entry | 1 | 0 ₂ | Do not care |

Table D.2: Test signal T1/T4 content of the BNCH/T

| Information element | Size (bits) | Values | Meaning |
|--|--------------------|--|--|
| PDU type | 2 | 10 ₂ | Broadcast PDU |
| Broadcast type | 2 | 00 ₂ | SYSINFO PDU |
| Main carrier | 12 | | Test signal carrier number (defined in ETSI EN 300 392-2 [3], clause 21.5.2) |
| Frequency band | 4 | | Test signal carrier band (defined in ETSI EN 300 392-2 [3], clause 21.5.2) |
| Offset | 2 | xx ₂ | Frequency offset (defined in ETSI EN 300 392-2 [3], clause 21.5.2) |
| Duplex spacing | 3 | | Defined in ETSI EN 300 392-2 [3], clause 21.5.2 |
| Reverse operation | 1 | 0 ₂ 1 ₂ | Normal (see ETSI EN 300 392-2 [3], clause 21.5.2) Reverse |
| No of common secondary control channels in use | 2 | 00 ₂ | None |
| MS_TXPWR_MAX_CELL | 3 | 000 ₂ | Reserved |
| | | 001 ₂ | 15 dBm |
| | | 010 ₂ | 20 dBm |
| | | 011 ₂ | 25 dBm |
| | | 100 ₂ | 30 dBm |
| | | 101 ₂ | 35 dBm |
| | | 110 ₂ | 40 dBm |
| | | 111 ₂ | 45 dBm |
| RXLEV_ACCESS_MIN | 4 | 0000 ₂ | Defined in ETSI EN 300 392-2 [3], clause 21 |
| ACCESS_PARAMETER | 4 | 0000 ₂ to 1111 ₂ | -53 dBm to -23 dBm in 2 dB steps for subsequent power adjustments |
| RADIO_DOWNLINK_TIMEOUT | 4 | 0000 ₂ | Disable Radio Downlink Counter (RDC) |
| Tx_on | 1 | 0 ₂ | Reception on |
| | | 1 ₂ | Transmission on |
| Tx_burst_type | 1 | 0 ₂ | Normal uplink burst |
| | | 1 ₂ | Control uplink burst |
| T1_T4_burst_type | 5 | 00000 ₂ | Reserved |
| | | 00001 ₂ | Type 1: TCH/7,2 (downlink) |
| | | 00010 ₂ | Type 2: SCH/F(downlink) |
| | | 00011 ₂ | Type 3: BSCH +SCH/HD (downlink) |
| | | 00100 ₂ | Type 4: TCH/2,4 N = 1 (downlink) |
| | | 00101 ₂ | Type 5: Reserved, see note 1 |
| | | 00110 ₂ | Type 6: Reserved, see note 1 |
| | | 00111 ₂ | Type 7: TCH/7,2 (uplink) |
| | | 01000 ₂ | Type 8: SCH/F (uplink) |
| | | 01001 ₂ | Type 9: STCH + STCH (uplink) |
| | | 01010 ₂ | Type 10: TCH/2,4 N = 1 (uplink) |
| | | 01011 ₂ | Type 11: SCH/HU + SCH/HU (uplink) |
| | | 01100 ₂ | Type 12: Reserved, see note 1 |
| | | 01101 ₂ | Type 13: random synchronization bursts |
| | | 01110 ₂ | Type 14: random synchronization sub-bursts |
| | | 01111 ₂ | Type 15: TCH/S PRBS tests (downlink) |
| | | 10000 ₂ | Type 16: TCH/S PRBS tests (uplink) |
| | | 10001 ₂ | Type 17: TCH/4,8 N = 1 (downlink) |
| | | 10010 ₂ | Type 18: TCH/4,8 N = 1 (uplink) |
| | | 10011 ₂ | Type 19: TCH/S speech codec test (downlink) |
| | | 10100 ₂ | Type 20: TCH/S speech codec test (uplink) |
| | | 10101 ₂ | Type 21: TCH-P8/10,8 |
| 10110 ₂ | Type 22: SCH-P8/HD | | |

| Information element | Size (bits) | Values | Meaning |
|---|-------------|--|---|
| | | 10111 ₂ | Type 23: SCH-P8/HU |
| | | 11000 ₂ | Type 24: SCH-P8/F |
| | | 11001 ₂ | Type 25: SCH-Q/HU |
| | | 11010 ₂ | Type 26: SCH-Q/U |
| | | 11011 ₂ | Type 27: SCH-Q/D |
| | | 11100 ₂ | Type 28: SCH-Q/RA |
| | | 11101 ₂ to 11110 ₂ | Reserved |
| | | 11111 ₂ | Extension |
| Loop_back | 1 | 0 ₂ | Loopback off |
| | | 1 ₂ | Loopback on |
| Error correction, (see note 2) | 1 | 0 ₂ | Error correction on |
| | | 1 ₂ | Error correction off |
| Extended burst type | 5 | 00000 ₂ | Reserved |
| Reserved, (see note 3) | 30 | All bits set to 0 ₂ | Reserved |
| QAM_payload_type (see note 4) | 5 | 00000 ₂ | 4-QAM rate = 1/2 |
| | | 00001 ₂ | 4-QAM rate = 1 |
| | | 00010 ₂ | 16-QAM rate = 1/2 |
| | | 00011 ₂ | 16-QAM rate = 1 |
| | | 00100 ₂ | 64-QAM rate = 1/2 |
| | | 00101 ₂ | 64-QAM rate = 2/3 |
| | | 00110 ₂ | 64-QAM rate = 1 |
| | | 00111 ₂ to 11111 ₂ | Reserved |
| Carrier bandwidth (see note 4) | 3 | 000 ₂ | 25 kHz |
| | | 001 ₂ | 50 kHz |
| | | 010 ₂ | 100 kHz |
| | | 011 ₂ | 150 kHz |
| | | 1XX ₂ | Reserved |
| Test signal width (see note 4) | 1 | 0 ₂ | One slot test signal |
| | | 1 ₂ | Four slots test signal |
| PRBS continuation (see note 5) | 2 | 00 ₂ | Pseudo random bit sequence continuation is undefined |
| | | 01 ₂ | Pseudo random bit sequence starts on the beginning of each multiframe |
| | | 10 ₂ | Pseudo random bit sequence continues from one multiframe to another |
| | | 11 ₂ | Reserved |
| Reserved (see note 3) | 26 | All bits set to 0 ₂ | Reserved |
| NOTE 1: Type 5, type 6 and type 12 were used for the TETRA Packet Data Optimized service which is now historical, and may not be available any other purpose. | | | |
| NOTE 2: This information element is used only when testing QAM bursts and should be set to 0 when testing phase modulation bursts. | | | |
| NOTE 3: The total length is 124 for phase modulation bursts. | | | |
| NOTE 4: This information element is only used for T4 burst type 25, 26, 27 and 28 and should be set to 0 in all the other cases. | | | |
| NOTE 5: Pseudo random bit sequence continues from one slot to another, when four slots test signal is used. | | | |

Table D.3: Test signal T4 content of the BSCH-Q/T

| Information element | Size (bits) | Values | Meaning |
|---------------------|-------------|--|--|
| System code | 4 | 0xxx ₂ | V+D reserved |
| | | 1xxx ₂ | Reserved |
| Base Colour Code | 6 | xxxxxx ₂ | Any BCC value 1 to 63 |
| Timeslot number | 2 | 00 ₂ | Timeslot 1 |
| Frame number | 5 | 10010 ₂ | Frame 18 |
| Multiframe number | 6 | 111100 ₂ | Multiframe 60 |
| Mobile Country Code | 10 | xxxxxxxxxx ₂ | Any MCC value 0 to 1 023 |
| Mobile Network Code | 14 | xxxxxxx xxxxxx ₂ | Any MNC value 0 to 16 383 |
| Main carrier | 12 | | Test signal carrier number (defined in ETSI EN 300 392-2 [3], clause 21.5.2) |
| Frequency band | 4 | | Test signal carrier band (defined in ETSI EN 300 392-2 [3], clause 21.5.2) |
| Offset | 2 | xx ₂ | Frequency offset (defined in ETSI EN 300 392-2 [3], clause 21.5.2) |
| Duplex spacing | 3 | | Defined in ETSI EN 300 392-2 [3], clause 21.5.2 |
| Reverse operation | 1 | 0 ₂ | Normal (see ETSI EN 300 392-2 [3], clause 21.5.2) |
| | | 1 ₂ | Reverse |
| MS_TXPWR_MAX_CELL | 3 | 000 ₂ | Reserved |
| | | 001 ₂ | 15 dBm |
| | | 010 ₂ | 20 dBm |
| | | 011 ₂ | 25 dBm |
| | | 100 ₂ | 30 dBm |
| | | 101 ₂ | 35 dBm |
| | | 110 ₂ | 40 dBm |
| 111 ₂ | 45 dBm | | |
| ACCESS_PARAMETER | 4 | 0000 ₂ to 1111 ₂ | -53 dBm to -23 dBm in 2 dB steps for subsequent power adjustments |
| Tx_on | 1 | 0 ₂ | Reception on |
| | | 1 ₂ | Transmission on |
| Tx_burst_type | 1 | 0 ₂ | Normal uplink burst |
| | | 1 ₂ | Control uplink burst |
| T1_T4_burst_type | 5 | 00000 ₂ to 11000 ₂ | Reserved |
| | | 11001 ₂ | Type 25: SCH-Q/HU |
| | | 11010 ₂ | Type 26: SCH-Q/U |
| | | 11011 ₂ | Type 27: SCH-Q/D |
| | | 11100 ₂ | Type 28: SCH-Q/RA |
| | | 11101 ₂ to 11110 ₂ | Reserved |
| 11111 ₂ | Extension | | |
| Loop_back | 1 | 0 ₂ | Loopback off |
| | | 1 ₂ | Loopback on |
| Error correction | 1 | 0 ₂ | Error correction on |
| | | 1 ₂ | Error correction off |
| QAM_payload_type | 5 | 00000 ₂ | 4-QAM rate = 1/2 |
| | | 00001 ₂ | 4-QAM rate = 1 |
| | | 00010 ₂ | 16-QAM rate = 1/2 |
| | | 00011 ₂ | 16-QAM rate = 1 |
| | | 00100 ₂ | 64-QAM rate = 1/2 |
| | | 00101 ₂ | 64-QAM rate = 2/3 |
| | | 00110 ₂ | 64-QAM rate = 1 |
| | | 00111 ₂ to 11111 ₂ | Reserved |
| Carrier bandwidth | 3 | 000 ₂ | 25 kHz |
| | | 001 ₂ | 50 kHz |

| Information element | Size (bits) | Values | Meaning |
|--------------------------------|-------------|--------------------------------|---|
| | | 01 ₂ | 100 kHz |
| | | 011 ₂ | 150 kHz |
| | | 1XX ₂ | Reserved |
| Test signal width | 1 | 0 ₂ | One slot test signal |
| | | 1 ₂ | Four slots test signal |
| PRBS continuation (see note 1) | 2 | 00 ₂ | Pseudo random bit sequence continuation is undefined |
| | | 01 ₂ | Pseudo random bit sequence starts on the beginning of each multiframe |
| | | 10 ₂ | Pseudo random bit sequence continues from one multiframe to another |
| | | 11 ₂ | Reserved |
| Reserved (see note 2) | 21 | All bits set to 0 ₂ | Reserved |

NOTE 1: Pseudo random bit sequence continues from one slot to another, when four slots test signal is used.
NOTE 2: The length of the BSCH-Q/T PDU is 117 bits.

Table D.4: Test signal T4 content of the BNCH-Q/T

| Information element | Size (bits) | Values | Meaning |
|--|-------------|--|--|
| PDU type | 2 | 10 ₂ | Broadcast PDU |
| Broadcast type | 2 | 00 ₂ | SYSINFO PDU |
| Main carrier | 12 | | Test signal carrier number (defined in ETSI EN 300 392-2 [3], clause 21.5.2) |
| Frequency band | 4 | | Test signal carrier band (defined in ETSI EN 300 392-2 [3], clause 21.5.2) |
| Offset | 2 | xx ₂ | Frequency offset (defined in ETSI EN 300 392-2 [3], clause 21.5.2) |
| Duplex spacing | 3 | | Defined in ETSI EN 300 392-2 [3], clause 21.5.2 |
| Reverse operation | 1 | 0 ₂ | Normal (see ETSI EN 300 392-2 [3], clause 21.5.2) |
| | | 1 ₂ | Reverse |
| No of common secondary control channels in use | 2 | 00 ₂ | None |
| MS_TXPWR_MAX_CELL | 3 | 000 ₂ | Reserved |
| | | 001 ₂ | 15 dBm |
| | | 010 ₂ | 20 dBm |
| | | 011 ₂ | 25 dBm |
| | | 100 ₂ | 30 dBm |
| | | 101 ₂ | 35 dBm |
| | | 110 ₂ | 40 dBm |
| | | 111 ₂ | 45 dBm |
| RXLEV_ACCESS_MIN | 4 | 0000 ₂ | Defined in ETSI EN 300 392-2 [3], clause 21 |
| ACCESS_PARAMETER | 4 | 0000 ₂ to 1111 ₂ | -53 dBm to -23 dBm in 2 dB steps for subsequent power adjustments |
| RADIO_DOWNLINK_TIMEOUT | 4 | 0000 ₂ | Disable Radio Downlink Counter (RDC) |
| Tx_on | 1 | 0 ₂ | Reception on |
| | | 1 ₂ | Transmission on |
| Tx_burst_type | 1 | 0 ₂ | Normal uplink burst |
| | | 1 ₂ | Control uplink burst |
| T1_T4_burst_type | 5 | 00000 ₂ to 11000 ₂ | Reserved |
| | | 11001 ₂ | Type 25: SCH-Q/HU |
| | | 11010 ₂ | Type 26: SCH-Q/U |
| | | 11011 ₂ | Type 27: SCH-Q/D |
| | | 11100 ₂ | Type 28: SCH-Q/RA |
| | | 11101 ₂ to 11110 ₂ | Reserved |
| 11111 ₂ | Extension | | |

| Information element | Size (bits) | Values | Meaning |
|----------------------|-------------|--|---------------------------|
| Loop_back | 1 | 0 ₂ | Loopback off |
| | | 1 ₂ | Loopback on |
| Error correction | 1 | 0 ₂ | Error correction on |
| | | 1 ₂ | Error correction off |
| Extended burst type | 5 | 00000 ₂ | Reserved |
| Base Colour Code | 6 | xxxxxx ₂ | Any BCC value 1 to 63 |
| Mobile Country Code | 10 | xxxxxxxxxx ₂ | Any MCC value 0 to 1 023 |
| Mobile Network Code | 14 | xxxxxxxxxxxxxx ₂ | Any MNC value 0 to 16 383 |
| QAM_payload_type | 5 | 00000 ₂ | 4-QAM rate = 1/2 |
| | | 00001 ₂ | 4-QAM rate = 1 |
| | | 00010 ₂ | 16-QAM rate = 1/2 |
| | | 00011 ₂ | 16-QAM rate = 1 |
| | | 00100 ₂ | 64-QAM rate = 1/2 |
| | | 00101 ₂ | 64-QAM rate = 2/3 |
| | | 00110 ₂ | 64-QAM rate = 1 |
| | | 00111 ₂ to 11111 ₂ | Reserved |
| Carrier bandwidth | 3 | 000 ₂ | 25 kHz |
| | | 001 ₂ | 50 kHz |
| | | 010 ₂ | 100 kHz |
| | | 011 ₂ | 150 kHz |
| | | 1XX ₂ | Reserved |
| Test signal width | 1 | 0 ₂ | One slot test signal |
| | | 1 ₂ | Four slots test signal |
| Reserved, (see note) | 89 | All bits set to 0 ₂ | Reserved |

NOTE: The total length of the PDU is 185.

D.2 Frequencies of spurious response

This annex provides a definition of the interfering frequencies which are used during measurement of the spurious response rejection.

The interfering frequencies which are used during measurement of the spurious response rejection are defined as the combined frequencies of two sets of frequencies:

- a) All frequencies (f_l) in integer steps of the bandwidth of the signal divided by four and within the limited frequency range:

$$f_{lo} - \sum_{i=1}^n f_{ij} - sr/2 \leq f_l \leq f_{lo} + \sum_{i=1}^n f_{ij} + sr/2$$

where (sr) is the receive band of the equipment, (f_{lo}) is the frequency of the local oscillator signal applied to the first mixer of the receiver and (f_{i1}, \dots, f_{in}) is the intermediate frequencies of the receiver.

- b) The discrete frequencies at which spurious response can occur outside the range determined in a) above for the remainder of the frequency range of interest up to 4 GHz determined as $nf_{lo} \pm f_{i1}$ and $pf_r \pm f_{i1}$, where n is an integer greater than or equal to 2, p is an integer greater than or equal to 1, (f_r) is the frequency of any other oscillator used to generate reference frequencies in the receiver and (f_{i1}) is the first intermediate frequencies of the receiver.

Frequencies less than f_{spur} offset from the wanted frequency of the receiver are excluded from frequency sets a) and b) where f_{spur} is defined in table D.5 below.

Table D.5: Offset frequency f_{spur} within which tests are excluded

| Channel bandwidth | Offset from nominal Rx frequency |
|-------------------|----------------------------------|
| 25 kHz | 50 kHz |
| 50 kHz | 100 kHz |
| 100 kHz | 200 kHz |
| 150 kHz | 300 kHz |

For the calculations a) and b) above, the manufacturer shall state the frequency of the receiver (f_{θ}), the frequency of the local oscillator signal (f_{lo}) applied to the 1st mixer of the receiver, the frequency (f_r) of any other oscillator used to generate reference frequencies in the receiver, the intermediate frequencies (f_{i1}, \dots, f_{in}) and the switching range (sr) of the receiver (ETSI EN 300 392-2 [3]).

Annex E (informative): Example arrangement for transmitter intermodulation measurement

This annex describes an example measurement arrangement for transmitter intermodulation, in accordance with the requirements of clause 7.4.3.2 of the present document.

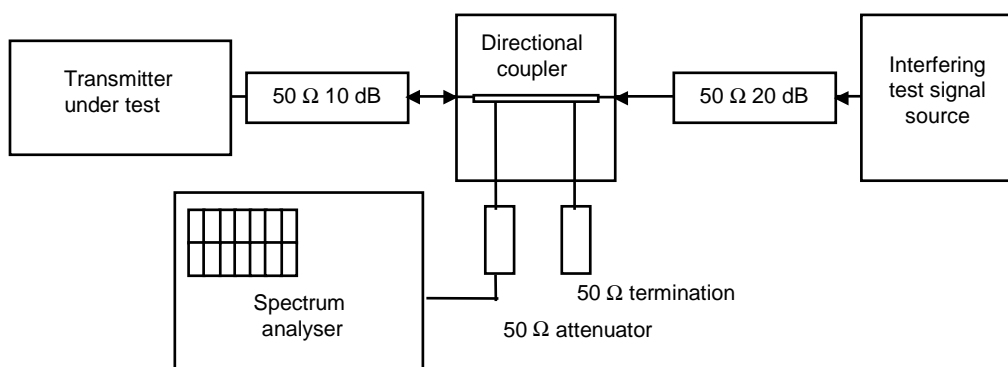

Figure E.1: Measurement arrangement

In this example arrangement, shown in figure E.1, the transmitter is connected to a 50 Ω 10 dB power attenuator and via a directional coupler to a spectrum analyser. An additional attenuator may be required between the directional coupler and the spectrum analyser to avoid overloading.

The interfering signal source can be either a transmitter providing the same power output as the transmitter under test and be of a similar type or a signal generator and a power amplifier of equivalent intermodulation attenuation as that required from the transmitter, capable of delivering the same output power as the transmitter under test. In either case the interfering signal source needs to be capable of generating a CW signal at power level equivalent to P_A .

The insertion loss of the directional coupler should be measured so levels may be adjusted to allow for it and it is effectively "calibrated out of the measurement system". The directional coupler needs to have sufficient bandwidth for the test and a directivity of more than 20 dB.

Annex F (informative): Maximum measurement uncertainty

The measurements described in the present document are based on the following assumptions:

- the measured value related to the corresponding limit is used to decide whether an equipment meets the requirements of the present document;
- the value of the measurement uncertainty for the measurement of each parameter is included in the test report.

Table F.1 shows the recommended values for the maximum measurement uncertainty figures.

Table F.1: Maximum measurement uncertainty

| Parameter | Uncertainty |
|--|----------------------------|
| Radio Frequency | $\pm 0,01$ ppm |
| RF Power (up to 160 W) | $\pm 0,75$ dB |
| Radiated RF power | ± 6 dB |
| Adjacent channel power | ± 3 dB |
| Conducted spurious emission of transmitter valid up to 12,75 GHz | ± 4 dB |
| Conducted spurious emission of receiver, valid up to 12,75 GHz | ± 7 dB |
| Two-signal measurement, valid up to 4 GHz | ± 4 dB |
| Three-signal measurement | ± 3 dB |
| Radiated emission of the transmitter, valid up to 4 GHz | ± 6 dB |
| Radiated emission of receiver, valid up to 4 GHz | ± 6 dB |
| Transmitter attack time | ± 20 % |
| Transmitter release time | ± 20 % |
| Transmitter transient frequency (frequency difference) | ± 250 Hz |
| Transmitter intermodulation | ± 3 dB |
| Modulation accuracy: <ul style="list-style-type: none"> • RMS vector error • Peak vector error | $\pm 1,0$ % $\pm 3,0$ % |
| Receiver desensitization | $\pm 0,5$ dB |
| Temperature | ± 2 K |
| Humidity | ± 10 % |
| NOTE: Valid up to 1 GHz for the RF parameters unless otherwise stated. | |

Annex G (informative): Selection of technical parameters to meet the essential requirements of Directive 2014/53/EU

ETSI EG 203 336 [i.9], clause 5 lists the technical parameters applicable to transmitters and receivers that should be considered when producing Harmonised Standards that are intended to cover the essential requirements in article 3.2 of Directive 2014/53/EU [i.2]. Table G.1 contains the parameters listed in ETSI EG 203 336 [i.9], clause 5 for transmitter and receiver, and cross references these to the clauses within the present document in which the requirements for measurement of such parameters are satisfied.

Table G.1: Cross reference of clauses in the present document to technical parameters for transmitter and receiver listed in ETSI EG 203 336

| Clause in ETSI EG 203 336 [i.9] | Parameter in ETSI EG 203 336 [i.9] | Clause in present document | Parameter in the present document |
|---|--|----------------------------|---|
| 5.2.2 | Transmitter power limits | 7.1 | Transmitter output power (conducted) |
| 5.2.3 | Transmitter power accuracy | 7.1 | Transmitter output power (conducted) |
| 5.2.4 | Transmitter spectrum mask | 7.2 7.3 | Adjacent and alternate channel power Unwanted emissions in the spurious domain |
| 5.2.5 | Transmitter frequency stability | 7.6 | Frequency error |
| 5.2.6 | Transmitter intermodulation attenuation | 7.4 | Intermodulation attenuation |
| 5.2.7.2 | Transmitter unwanted emissions in the out of band domain | 7.2 | Adjacent and alternate channel power |
| 5.2.7.3 | Transmitter unwanted emissions in the spurious domain | 7.3 | Unwanted emissions in the spurious domain note 1 |
| 5.2.8 | Transmitter time domain characteristics | 7.5 | Adjacent channel transient power measurements |
| 5.2.9 | Transmitter transients | 7.5 | Adjacent channel transient power measurements |
| 5.3.2 | Receiver sensitivity | 8.2 | Receiver sensitivity |
| 5.3.3 | Receiver co-channel rejection | 8.6 | Co channel rejection |
| 5.3.4.2.1 | Receiver adjacent channel selectivity | 8.4 | Adjacent channel selectivity |
| 5.3.4.2.2 | Receiver adjacent band selectivity | 8.3 | Blocking or desensitization |
| 5.3.4.3 | Receiver blocking | 8.3 | Blocking or desensitization |
| 5.3.4.4 | Receiver spurious response rejection | 8.8 | Spurious response rejection |
| 5.3.4.5 | Receiver radio-frequency intermodulation | 8.7 | Intermodulation response rejection |
| 5.3.5 | Receiver unwanted emissions in the spurious domain | 8.5 | Spurious radiations See note 2 |
| 5.3.6.1 | Receiver dynamic range | 8.4 8.3 8.7 | Adjacent channel selectivity Blocking or desensitization Intermodulation response rejection See note 3 |
| 5.3.6.2 | Reciprocal mixing | 8.4 8.3 | Adjacent channel selectivity Blocking or desensitization |
| NOTE 1: Clause 7.3 of the present document specifies measurements for both conducted and radiated unwanted emissions in the spurious domain from the transmitter under test. | | | |
| NOTE 2: Clause 8.5 of the present document specifies measurements for both conducted and radiated unwanted emissions in the spurious domain from the receiver under test. | | | |
| NOTE 3: ETSI EG 203 336 [i.9], clause 5.3.6.1 considers that the dynamic range of a receiver can be implicitly covered where interference characteristics are specified in terms of selectivity requirements, including blocking. | | | |

Annex H (informative): Change History

| Version | Information about changes |
|---------|---------------------------|
| 1.1.1 | First publication |
| | |

History

| Document history | | |
|-------------------------|------------|---|
| V1.1.0 | April 2021 | EN Approval Procedure AP 20210630: 2021-04-01 to 2021-06-30 |
| V1.1.1 | July 2021 | Publication |
| | | |
| | | |
| | | |