



**Amplifiers and active antennas for
TV broadcast reception in domestic premises;
Harmonised Standard covering the essential requirements
of article 3.2 of Directive 2014/53/EU**

Reference

DEN/ERM-TG17-16

Keywords

amplification, antenna, broadcasting, harmonised standard

ETSI

650 Route des Lucioles
F-06921 Sophia Antipolis Cedex - FRANCE

Tel.: +33 4 92 94 42 00 Fax: +33 4 93 65 47 16

Siret N° 348 623 562 00017 - NAF 742 C
Association à but non lucratif enregistrée à la
Sous-Préfecture de Grasse (06) N° 7803/88

Important notice

The present document can be downloaded from:
<http://www.etsi.org/standards-search>

The present document may be made available in electronic versions and/or in print. The content of any electronic and/or print versions of the present document shall not be modified without the prior written authorization of ETSI. In case of any existing or perceived difference in contents between such versions and/or in print, the only prevailing document is the print of the Portable Document Format (PDF) version kept on a specific network drive within ETSI Secretariat.

Users of the present document should be aware that the document may be subject to revision or change of status. Information on the current status of this and other ETSI documents is available at
<https://portal.etsi.org/TB/ETSIDeliverableStatus.aspx>

If you find errors in the present document, please send your comment to one of the following services:
<https://portal.etsi.org/People/CommiteeSupportStaff.aspx>

Copyright Notification

No part may be reproduced or utilized in any form or by any means, electronic or mechanical, including photocopying and microfilm except as authorized by written permission of ETSI.

The content of the PDF version shall not be modified without the written authorization of ETSI.
The copyright and the foregoing restriction extend to reproduction in all media.

© European Telecommunications Standards Institute 2016.
All rights reserved.

DECT™, **PLUGTESTS™**, **UMTS™** and the ETSI logo are Trade Marks of ETSI registered for the benefit of its Members.
3GPP™ and **LTE™** are Trade Marks of ETSI registered for the benefit of its Members and of the 3GPP Organizational Partners.
GSM® and the GSM logo are Trade Marks registered and owned by the GSM Association.

Contents

Intellectual Property Rights	5
Foreword.....	5
Modal verbs terminology.....	5
Introduction	5
1 Scope	6
2 References	6
2.1 Normative references	6
2.2 Informative references.....	6
3 Definitions, symbols and abbreviations	7
3.1 Definitions	7
3.2 Symbols.....	7
3.3 Abbreviations	7
4 Technical requirements specifications	8
4.1 Environmental profile.....	8
4.2 General conditions of measurement	8
4.2.1 General.....	8
4.2.2 Equipment configuration	8
4.2.3 Test conditions.....	8
4.2.3.1 General	8
4.2.3.2 Normal test conditions	9
4.2.3.2.1 Normal temperature and humidity.....	9
4.2.3.2.2 Extreme temperatures	9
4.3 General assessment.....	9
4.4 Equipment categorization.....	9
4.5 Conformance requirements	10
4.5.1 Gain	10
4.5.1.1 Definition	10
4.5.1.2 Limits	10
4.5.1.3 Conformance.....	11
4.5.2 Noise figure	11
4.5.2.1 Definition	11
4.5.2.2 Limits	11
4.5.2.3 Conformance.....	11
4.5.3 Amplifier intermodulation	12
4.5.3.1 Definition	12
4.5.3.2 Limits	12
4.5.3.3 Conformance.....	12
4.5.4 Return loss	12
4.5.4.1 Definition	12
4.5.4.2 Limits	13
4.5.4.3 Conformance.....	13
4.5.5 Selectivity	13
4.5.5.1 Definition	13
4.5.5.2 Classification 1.....	13
4.5.5.3 Classification 2.....	14
4.5.5.4 Classification 3.....	14
4.5.5.5 Classification 4.....	15
4.5.5.6 Conformance.....	16
4.5.6 Active antenna gain	16
4.5.6.1 Definition	16
4.5.6.2 Limits	16
4.5.6.3 Conformance.....	16
4.5.7 Active antenna figure of merit	16
4.5.7.1 Definition	16

4.5.7.2	Limits	17
4.5.7.3	Conformance	17
4.5.8	Active antenna intermodulation	17
4.5.8.1	Definition	17
4.5.8.2	Limits	17
4.5.8.3	Conformance	17
4.5.9	Internal immunity	18
4.5.9.1	Definition	18
4.5.9.2	Limits	18
4.5.9.3	Conformance	18
4.5.10	RF Connectors	18
5	Testing for compliance with technical requirements	18
5.1	Environmental conditions for testing	18
5.2	Interpretation of the measurement results	18
5.3	Methods of measurement	19
5.3.1	Amplifier gain	19
5.3.2	Noise figure	19
5.3.3	Amplifier intermodulation	21
5.3.4	Return loss	22
5.3.5	Selectivity	22
5.3.6	Active antenna gain	23
5.3.7	Active antenna figure of merit	23
5.3.8	Active antenna intermodulation	24
5.3.9	Internal immunity	24
5.3.9.1	Method of measurement	24
Annex A (informative):	Relationship between the present document and the essential requirements of Directive 2014/53/EU	25
Annex B (informative):	Active Antenna Theory	26
Annex C (informative):	Change History	28
History		29

Intellectual Property Rights

IPRs essential or potentially essential to the present document may have been declared to ETSI. The information pertaining to these essential IPRs, if any, is publicly available for **ETSI members and non-members**, and can be found in ETSI SR 000 314: "*Intellectual Property Rights (IPRs); Essential, or potentially Essential, IPRs notified to ETSI in respect of ETSI standards*", which is available from the ETSI Secretariat. Latest updates are available on the ETSI Web server (<https://ipr.etsi.org>).

Pursuant to the ETSI IPR Policy, no investigation, including IPR searches, has been carried out by ETSI. No guarantee can be given as to the existence of other IPRs not referenced in ETSI SR 000 314 (or the updates on the ETSI Web server) which are, or may be, or may become, essential to the present document.

Foreword

This final draft Harmonised European Standard (EN) has been produced by ETSI Technical Committee Electromagnetic compatibility and Radio spectrum Matters (ERM), and is now submitted for the Vote phase of the ETSI standards EN Approval Procedure.

The present document has been prepared under the Commission's standardisation request C(2015) 5376 final [i.4] to provide one voluntary means of conforming to the essential requirements of Directive 2014/53/EU on the harmonisation of the laws of the Member States relating to the making available on the market of radio equipment and repealing Directive 1999/5/EC [i.1].

Once the present document is cited in the Official Journal of the European Union under that Directive, compliance with the normative clauses of the present document given in table A.1 confers, within the limits of the scope of the present document, a presumption of conformity with the corresponding essential requirements of that Directive and associated EFTA regulations.

Other Union legislation may be applicable to the product(s) falling within the scope of the present document.

Proposed national transposition dates	
Date of latest announcement of this EN (doa):	3 months after ETSI publication
Date of latest publication of new National Standard or endorsement of this EN (dop/e):	6 months after doa
Date of withdrawal of any conflicting National Standard (dow):	18 months after doa

Modal verbs terminology

In the present document "**shall**", "**shall not**", "**should**", "**should not**", "**may**", "**need not**", "**will**", "**will not**", "**can**" and "**cannot**" are to be interpreted as described in clause 3.2 of the [ETSI Drafting Rules](#) (Verbal forms for the expression of provisions).

"**must**" and "**must not**" are **NOT** allowed in ETSI deliverables except when used in direct citation.

Introduction

The present document is a Harmonised Standard for amplifiers and active antennas used for broadcast TV reception from 470 MHz to 790 MHz and VHF (174 MHz to 230 MHz).

The primary purpose of the present document is to specify technical parameters to limit the interfering effects caused by unwanted signals on TV reception.

1 Scope

The present document covers amplifiers and indoor active antennas for broadcast TV and sound reception at UHF (470 MHz to 790 MHz) and at VHF (174 MHz to 230 MHz).

The present document covers the essential requirements of article 3.2 of Directive 2014/53/EU [i.1] under the conditions identified in annex A.

2 References

2.1 Normative references

References are specific, identified by date of publication and/or edition number or version number. Only the cited version applies.

Referenced documents which are not found to be publicly available in the expected location might be found at <http://docbox.etsi.org/Reference>.

NOTE: While any hyperlinks included in this clause were valid at the time of publication, ETSI cannot guarantee their long-term validity.

The following referenced documents are necessary for the application of the present document.

- [1] CENELEC EN 50083-2:2012: "Cable networks for television signals, sound signals and interactive services - Part 2: Electromagnetic compatibility for equipment".

2.2 Informative references

References are either specific (identified by date of publication and/or edition number or version number) or non-specific. For specific references, only the cited version applies. For non-specific references, the latest version of the referenced document (including any amendments) applies.

NOTE: While any hyperlinks included in this clause were valid at the time of publication, ETSI cannot guarantee their long-term validity.

The following referenced documents are not necessary for the application of the present document but they assist the user with regard to a particular subject area.

- [i.1] Directive 2014/53/EU of the European Parliament and of the Council of 16 April 2014 on the harmonisation of the laws of the Member States relating to the making available on the market of radio equipment and repealing Directive 1999/5/EC.
- [i.2] Rohde & Schwarz Application Note 1MA78-0E: "The Y Factor Technique for Noise Figure Measurements", May 2012.
- [i.3] Agilent Technologies Application note 1439 5988-8571EN: "Measuring Noise Figure with a Spectrum Analyzer", 2003.
- [i.4] Commission Implementing Decision C(2015) 5376 final of 4.8.2015 on a standardisation request to the European Committee for Electrotechnical Standardisation and to the European Telecommunications Standards Institute as regards radio equipment in support of Directive 2014/53/EU of the European Parliament and of the Council.
- [i.5] Kraus, J. D.: "Antennas", second edition, McGraw-Hill International 1988.
- [i.6] ETSI TR 100 028 all parts (V1.4.1) (12-2001): "Electromagnetic compatibility and Radio spectrum Matters (ERM); Uncertainties in the measurement of mobile radio equipment characteristics".

- [i.7] IEC 61169-24:2009: "Radio-frequency connectors - Part 24: Sectional specification - Radio frequency coaxial connectors with screw coupling, typically for use in 75 Ω cable networks (type F)".
- [i.8] IEC 61169-2:2007: "Radio-frequency connectors - Part 2: Sectional specification - Radio frequency coaxial connectors of type 9,52".

3 Definitions, symbols and abbreviations

3.1 Definitions

For the purpose of the present document, the following terms and definitions apply:

amplifier: indoor or outdoor equipment intended to amplify terrestrial broadcast signals

active antenna: antenna equipped with an integrated low noise amplifier for indoor use (equipment type A)

category: method of classifying equipment according to its type {P,D,L} and selectivity class {0,1,2,3,4}

Digital Terrestrial Television (DTT): platform for the delivery of digital TV content via terrestrial broadcasting

domestic amplifier: general purpose amplifier for use in domestic premises intended to amplify terrestrial broadcast signals (equipment type D)

internal immunity: ability of a device, equipment or system to perform without degradation in the presence of electromagnetic disturbances appearing at its normal input terminals or antennas

launch amplifier: high output level amplifier used to distribute terrestrial broadcast signals to multiple receivers (equipment type L)

preamplifier: low noise amplifier with one or more outputs typically used immediately after a terrestrial receive antenna

NOTE: A masthead amplifier is a preamplifier for outdoor use with terrestrial broadcast signals (equipment type P).

UHF (Ultra High Frequency) band: broadcast band from 470 MHz to 790 MHz divided into 40 channels, each 8 MHz wide, numbered from 21 to 60

VHF (Very High Frequency) band: broadcast band from 174 MHz to 230 MHz divided into 8 channels, each 7 MHz wide, numbered from 5 to 12

3.2 Symbols

For the purposes of the present document, the following symbols apply:

<i>nf</i>	Noise Figure, expressed in dB
F	Noise Factor
IM3	3rd order intercept

3.3 Abbreviations

For the purposes of the present document, the following abbreviations apply:

AAUT	Active Antenna Under Test
AC	Alternating Current
AUT	Amplifier Under Test
CW	Carrier Wave
DC	Direct Current
ENR	Excess Noise Ratio
E-UTRA	Evolved Universal Terrestrial Radio Access

GTEM	Gigahertz Transverse ElectroMagnetic
IMD	Intermodulation Distortion
IMT	International Mobile Telecommunication
MATV	Master Antenna Television
RF	Radio Frequency
RL	Return Loss
SNR	Signal to Noise Ratio
SWR	Standing Wave Ratio
TOI	Third Order Intercept
TV	TeleVision
UHF	Ultra High Frequency
VHF	Very High Frequency

4 Technical requirements specifications

4.1 Environmental profile

The technical requirements of the present document apply under the environmental profile for operation of the equipment, which shall be declared by the manufacturer. The equipment shall comply with all the technical requirements of the present document which are identified as applicable in annex A at all times when operating within the boundary limits of the declared operational environmental profile.

4.2 General conditions of measurement

4.2.1 General

This clause gives the general operational conditions. The product-specific operating conditions will be derived from the product description and documentation and stated in the test report.

The levels of the test signals shall be expressed either in terms of the power relative to 1 mW (dBm) for amplifiers or the field strength relative to 1 μ V/m (dB μ V/m) for antennas.

4.2.2 Equipment configuration

Power and signal distribution, grounding, interconnecting cabling and physical placement of equipment of a test system shall simulate the typical application and usage in so far as is practicable, and shall be in accordance with the relevant product specifications.

Only configurations within the range of setting likely to occur in normal use need be considered.

4.2.3 Test conditions

4.2.3.1 General

The equipment shall be tested under normal test conditions according to the relevant product and basic standards or to the information accompanying the equipment, which shall be within the manufacturers declared range of humidity, temperature and supply voltage. The test conditions shall be recorded in the test report.

The test configuration and mode of operation shall be representative of the intended use and shall be recorded in the test report.

Typical test equipment will usually have a characteristic impedance of 50 Ω and antennas or amplifiers typically have a characteristic impedance of 75 Ω . In such cases, impedance matching attenuators or transformers should be used to interface to the equipment under test.

The equipment under test should be fed by the intended power supply supplied by the manufacturer or a suitable equivalent.

For amplifiers with multiple inputs or multiple outputs, any ports that would otherwise be unconnected shall be terminated in a well-matched load. For devices with multiple outputs, all outputs should be tested.

4.2.3.2 Normal test conditions

4.2.3.2.1 Normal temperature and humidity

The normal temperature and humidity conditions for tests shall be a combination of temperature and humidity within the following ranges:

- temperature: +15 °C to +35 °C;
- relative humidity: 20 % to 95 %, non-condensing.

4.2.3.2.2 Extreme temperatures

For tests at extreme temperatures, measurements shall be made at a lower temperature of -10 °C and an upper temperature of +55 °C.

4.3 General assessment

The manufacturer shall at the time of submission of the equipment for test, supply the following information to be recorded in the test report:

- the intended functions of the equipment which shall be in accordance with the documentation accompanying the equipment;
- the equipment category, as defined in clause 4.4;
- the ancillary equipment (power supply for example) to be supplied with the equipment for testing (where applicable);
- an exhaustive list of ports, classified as either power or signal. Power ports shall further be classified as AC or DC power;
- the operating frequency ranges over which the equipment is intended to operate;
- the environment(s) in which the equipment is intended to be used.

4.4 Equipment categorization

The equipment covered by the present document is classified according to table 1 and table 2. The equipment type and selectivity classification appropriate for the RF environment are combined to describe an equipment category.

Table 1: Equipment types

Equipment Type	Description	Notes
P	Preamplifiers	Low noise amplifiers with one or more outputs.
D	Domestic amplifiers	Amplifiers with one or more outputs not intended for low noise applications.
L	Launch amplifiers	High output level amplifiers used for MATV systems.
A	Active antennas	Amplified domestic antenna for indoor use.

Table 2: RF environment and selectivity classification

Selectivity Classification	Intended RF environment	Notes
0	IMT is not deployed in the range from 694 MHz to 862 MHz. Devices have wideband response, with no selectivity.	This classification is expected to have a limited lifetime and may be withdrawn subject to European decisions relating to the band 694 MHz to 790 MHz. Wideband components (e.g. launch amplifiers) may still be appropriate where filters are included elsewhere in the system.
1	IMT is deployed above 700 MHz (E-UTRA band 28 and band 20). Devices have selectivity to reject IMT signals above 700 MHz.	Provides selectivity to reject LTE-700 (E-UTRA band 28) and LTE-800 (E-UTRA band 20) signals.
2	IMT is deployed above 700 MHz or below 470 MHz. Devices have selectivity to reject IMT signals below 470 MHz and above 700 MHz.	Provides selectivity to reject LTE-700 (E-UTRA band 28), LTE-800 (E-UTRA band 20) and IMT signals below 470 MHz.
3	IMT is deployed above 790 MHz (E-UTRA band 20). Devices have selectivity to reject IMT signals above 790 MHz. DTT is not deployed in channel 60 (782 MHz to 790 MHz).	Provides selectivity to reject LTE-800 (E-UTRA band 20). Filter rolls off in DTT channel 60.
4	IMT is deployed above 790 MHz (E-UTRA band 20). Devices have selectivity to reject IMT signals above 790 MHz. DTT is deployed in channel 60 (782 MHz to 790 MHz).	Provides selectivity to reject LTE-800 (E-UTRA band 20). DTT channel 60 preserved.

For example, equipment type P and selectivity classification 0 denotes a wideband preamplifier (equipment category P0) intended for use where IMT is not deployed in the range from 694 MHz to 862 MHz.

4.5 Conformance requirements

4.5.1 Gain

4.5.1.1 Definition

This is the ratio of the power at the output of an amplifier to the power at the input expressed in dB.

4.5.1.2 Limits

The permitted gain variation with frequency shall be as shown in table 3.

Table 3: Amplifier gain variation

Test number	Test description	Frequency Range			Category {P,D,L}{0}
		Start (MHz)	Stop (MHz)	Step (MHz)	Maximum gain variation (dB)
1	UHF amplifier gain variation	470	790	≤ 2	4
2	VHF amplifier gain variation	174	230	≤ 1	4
NOTE 1: The gain variation is the difference between the maximum gain and the minimum gain over the specified test frequency range.					
NOTE 2: For amplifiers operating over a reduced frequency band, the start and stop frequencies shall be chosen to match the stated operating frequency range.					
NOTE 3: The maximum gain measured over the specified test frequencies shall be equal to or greater than the gain stated by the manufacturer.					
NOTE 4: For frequency selective equipment (selectivity classification 1–4), limits in clause 4.5.5 shall apply.					

4.5.1.3 Conformance

Conformance tests described in clause 5.3.1 shall be carried out.

4.5.2 Noise figure

4.5.2.1 Definition

The noise factor (F) is defined as the degradation of the signal-to-noise ratio (SNR) resulting from noise generated by the amplifier:

$$F = \frac{C_1/N_1}{C_2/N_2}$$

where: C_1 = power of input signal;

C_2 = power of output signal;

N_1 = power of noise at input (thermal noise at 290 K);

N_2 = power of noise at output.

The noise figure, nf , is the noise factor converted to decibel notation:

$$nf = 10 \times \log_{10}(F)$$

The noise figure (nf) is defined at the standard noise temperature (290 K) over the bandwidth of interest.

4.5.2.2 Limits

The maximum noise figure limit shall be as specified in table 4.

Table 4: Amplifier noise figure

Test number	Test description	Test Frequencies (MHz)	Maximum noise figure (dB)		
			Category {P,D}{0}	Category {P,D}{1,2,3,4}	Category {L}{0,1,2,3,4}
1	Noise figure UHF amplifiers	F_0	3	4	7
		F_1			
		F_2			
2	Noise figure VHF amplifiers	205,5	3	4	7

NOTE: The test frequencies F_0, F_1, F_2 are defined in table 5.

Table 5: Test frequencies

Test Frequencies (MHz)	Category {P,D,L}{0}	Category {P,D,L}{1}	Category {P,D,L}{2}	Category {P,D,L}{3}	Category {P,D,L}{4}
F_0	470	470	478	470	470
F_1	666	586	586	626	626
F_2	862	696	696	774	782

NOTE: For amplifiers operating over a reduced frequency band, test frequencies corresponding to the maximum -8 MHz, minimum +8 MHz and centre frequency of the stated band of operation shall be chosen.

4.5.2.3 Conformance

Conformance tests described in clause 5.3.2 shall be carried out.

4.5.3 Amplifier intermodulation

4.5.3.1 Definition

Intermodulation distortion is a non-linear distortion characterized by the appearance of output signals at frequencies corresponding to the sum and difference of the fundamentals and harmonics of the signals applied at the input. The linearity of an RF amplifier is characterized in terms of its third order intercept, which is measured using a two-tone test. Wanted signals at frequencies F_1 and F_2 are applied at the amplifier input and the non-linearity manifests itself in the form of unwanted third order intermodulation products at the output generated at frequencies $2 F_1 - F_2$ and $2 F_2 - F_1$.

The third-order input intercept (TOI_{input}) value is an imaginary point corresponding to the input level of each of a pair of CW tones that would generate equal levels of the wanted and unwanted third-order products at the output of the amplifier. This point is never reached, as an amplifier will saturate before this condition can occur, but it is useful as it allows the level of intermodulation distortion to be predicted at a given input signal level.

4.5.3.2 Limits

The value of TOI_{input} shall exceed the values shown in table 6.

Table 6: Third order input intercept limits

Test number	Test description	Test Frequencies (MHz)	Minimum Input Intercept (dBm)
			Category {P,D,L}{0,1,2,3,4}
1	UHF amplifier input TOI	F_0	-4
		F_1	
		F_2	
2	VHF amplifier input TOI	205,5	-4

NOTE: The test frequencies F_0, F_1, F_2 are defined in table 5.

4.5.3.3 Conformance

Conformance tests described in clause 5.3.3 shall be carried out.

4.5.4 Return loss

4.5.4.1 Definition

The return loss, RL , is a measure of the attenuation of the reflected signal, P_{ref} , relative to the incident signal, P_{inc} , that results when an amplifier (or other RF component) is connected to an RF system of a given characteristic impedance Z_0 . The reflected signal results from a mismatch between the characteristic impedance of the system and the terminal impedances of the amplifier.

$$\begin{aligned}
 RL(dB) &= -10 \times \log_{10} \left(\frac{P_{ref}}{P_{inc}} \right) \\
 &= -20 \times \log_{10} \left| \frac{Z_a - Z_0}{Z_a + Z_0} \right|
 \end{aligned}$$

where:

Z_a is the impedance of the amplifier (defined separately at the input and output).

P_{ref} is the power reflected by the AUT in the linear domain.

P_{inc} is the incident power in the linear domain.

The return loss is thus a measure of mismatch between the amplifier (input or output) impedance and the characteristic impedance of the RF system.

4.5.4.2 Limits

At the input port, the return loss (RL_{input}) depends upon the class of amplifier and shall be equal to or greater than the values in table 7.

Table 7: Input return loss limits

Test number	Test description	Test Frequencies (MHz)	Minimum input return loss (dB)	
			Category {P}{0,1,2,3,4}	Category {D,L}{0,1,2,3,4}
1	UHF amplifier input return loss	F_0	5	8
		F_1		
		F_2		
2	VHF amplifier input return loss	205,5	5	8

NOTE: The test frequencies F_0, F_1, F_2 are defined in table 5.

The value of return losses at the output port (RL_{output}) shall be equal to or greater than the limits in table 8.

Table 8: Output return loss limits

Test number	Test description	Test Frequencies (MHz)	Minimum output return loss (dB)	
			Category {P}{0,1,2,3,4}	Category {D,L}{0,1,2,3,4}
1	UHF amplifier output return loss	F_0	8	8
		F_1		
		F_2		
2	VHF amplifier output return loss	205,5	8	8

NOTE: The test frequencies F_0, F_1, F_2 are defined in table 5.

4.5.4.3 Conformance

Conformance tests described in clause 5.3.4 shall be carried out.

4.5.5 Selectivity

4.5.5.1 Definition

This clause applies for equipment claiming resilience to IMT interference (i.e. selectivity classifications {1,2,3,4} as defined in table 2.

4.5.5.2 Classification 1

Adjacent band selectivity shall not exceed the limits specified in table 9, additionally shown in figure 1.

Table 9: Adjacent band selectivity limits (classification 1)

Frequency (MHz)	Relative gain g_r (dB)	
	Maximum (dB)	Minimum (dB)
$470 < F \leq 686$	+2	-2
$686 < F \leq 694$	+2	-4
$694 < F \leq 703$	+2	-
$703 < F \leq 738$	-10	-
$738 < F \leq 960$	-25	-

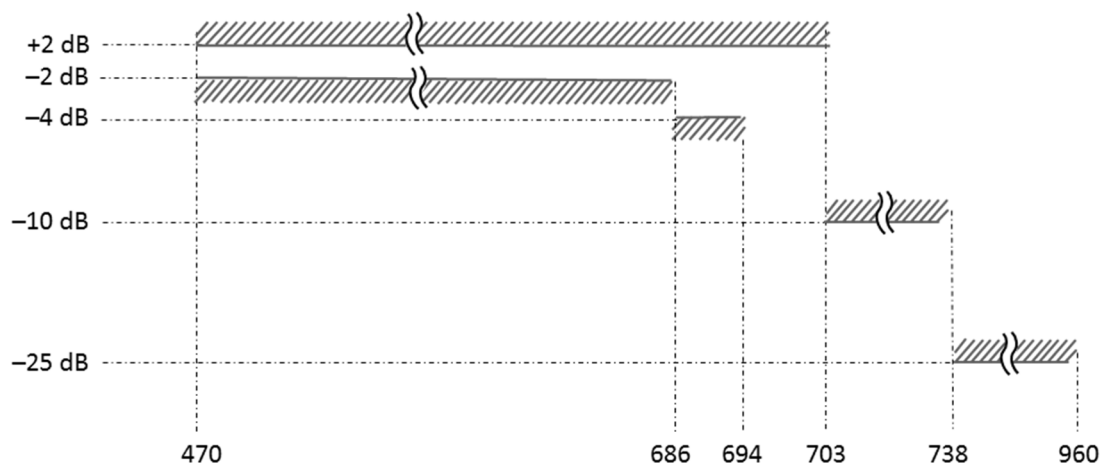

Figure 1: Adjacent band selectivity limits (classification 1)

4.5.5.3 Classification 2

Adjacent band selectivity shall not exceed the limits specified in table 10, additionally shown in figure 2.

Table 10: Adjacent band selectivity limits (classification 2)

Frequency (MHz)	Relative gain g_r (dB)	
	Maximum (dB)	Minimum (dB)
$410 < F \leq 467$	-	-10
$467 < F \leq 470$	+2	-
$470 < F \leq 478$	+2	-4
$478 < F \leq 686$	+2	-2
$686 < F \leq 694$	+2	-4
$694 < F \leq 703$	+2	-
$703 < F \leq 738$	-10	-
$738 < F \leq 960$	-25	-

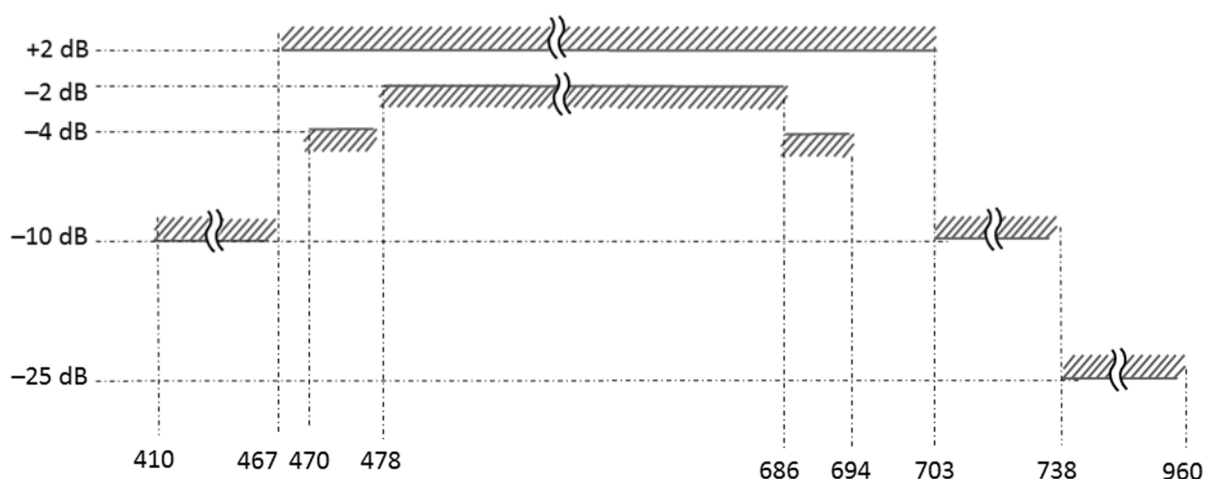

Figure 2: Adjacent band selectivity limits (classification 2)

4.5.5.4 Classification 3

Adjacent band selectivity shall not exceed the limits specified in table 11, additionally shown in figure 3.

Table 11: Adjacent band selectivity limits (classification 3)

Frequency (MHz)	Relative gain g_r (dB)	
	Maximum (dB)	Minimum (dB)
$470 < F \leq 774$	+2	-2
$774 < F \leq 782$	+2	-4
$782 < F \leq 791$	+2	-
$791 < F \leq 960$	-15	-

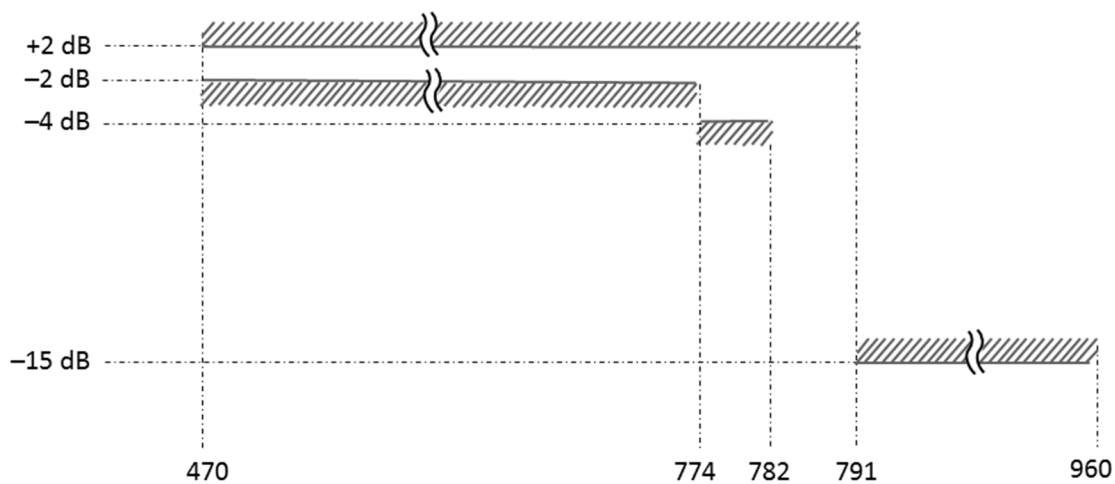
**Figure 3: Adjacent band selectivity limits (classification 3)**

4.5.5.5 Classification 4

Adjacent band selectivity shall not exceed the limits specified in table 12, additionally shown in figure 4.

Table 12: Adjacent band selectivity limits (classification 4)

Frequency (MHz)	Relative gain g_r (dB)	
	Maximum (dB)	Minimum (dB)
$470 < F \leq 782$	+2	-2
$782 < F \leq 790$	+2	-4
$790 < F \leq 796$	+2	-
$796 < F \leq 960$	-15	-

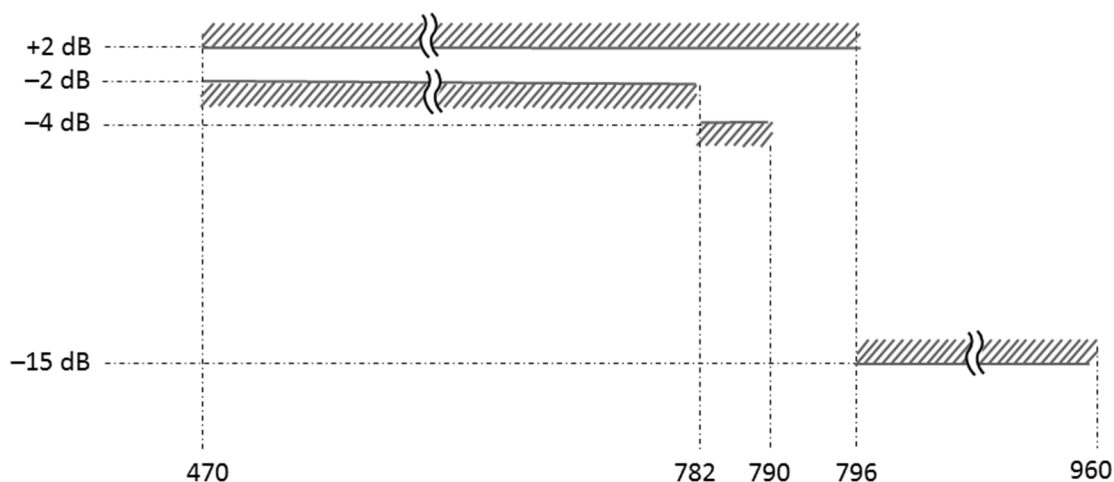

Figure 4: Adjacent band selectivity limits (classification 4)

4.5.5.6 Conformance

Conformance tests described in clause 5.3.5 shall be carried out.

4.5.6 Active antenna gain

4.5.6.1 Definition

The active antenna gain is defined as the sum of the passive antenna gain and the amplifier gain.

4.5.6.2 Limits

The active antenna gain shall fall between the maximum and minimum values given in table 13.

Table 13: Active antenna gain limits

Test number	Test description	Frequency Range			Category {A}{0,1,2,3,4}	
		Start (MHz)	Stop (MHz)	Step (MHz)	Minimum gain (dBi)	Maximum gain (dBi)
1	UHF antenna gain	478	854	≤ 2	6	20
2	VHF antenna gain	181	223	≤ 1	3	17

NOTE 1: For antennas operating over a reduced frequency band, test frequencies corresponding to the maximum -8 MHz, minimum +8 MHz and centre frequency of the stated band of operation shall be chosen.

NOTE 2: The maximum gain measured over the specified test frequencies shall be equal to or greater than the gain stated by the manufacturer.

4.5.6.3 Conformance

Conformance tests described in clause 5.3.6 shall be carried out.

4.5.7 Active antenna figure of merit

4.5.7.1 Definition

A useful figure of merit (FoM) for an active antenna is the passive antenna gain, g_i , less the amplifier noise figure f_a . For further technical details, see annex B.

4.5.7.2 Limits

The measured value of the FoM for the AAUT shall exceed the values in table 14 at each of the specified test frequencies.

Table 14: Antenna figure of merit

Test number	Test description	Test Frequencies (MHz)	Category {A}{0,1,2,3,4}
			Minimum FoM , ($g_i - f_a$) (dB)
1	UHF antenna FoM	478	-5
		630	
		782	
2	VHF antenna FoM	205,5	-8
NOTE: For antennas operating over a reduced frequency band, test frequencies shall be chosen as follows: minimum frequency +8 MHz, centre frequency, maximum frequency -8 MHz.			

4.5.7.3 Conformance

Conformance tests described in clause 5.3.7 shall be carried out.

4.5.8 Active antenna intermodulation

4.5.8.1 Definition

Intermodulation distortion is a non-linear distortion characterized by the appearance of frequencies corresponding to the sum and difference frequencies of the fundamentals and harmonics that are transmitted through the device.

The third-order input intercept (e_{toi}) value is an imaginary point corresponding to the input field strength of each of a pair of CW tones that would generate equal levels of the wanted and unwanted third-order products at the output of the active antenna. This point is never reached, as the active antenna will saturate before this condition can occur, but it is useful as it allows the level of intermodulation distortion to be predicted at a given input signal.

4.5.8.2 Limits

The input referred third order intercept e_{toi} shall exceed the values in table 15.

Table 15: Active antenna input intercept

Test number	Test description	Test Frequencies (MHz)	Category {A}{0,1,2,3,4}
			Minimum e_{toi} (dB μ V/m)
1	UHF antenna input intercept	478	130
		630	
		782	
2	VHF antenna input intercept	205,5	130
NOTE: For antennas operating over a reduced frequency band, test frequencies shall be chosen as follows: minimum frequency +8 MHz, centre frequency, maximum frequency -8 MHz.			

4.5.8.3 Conformance

Conformance tests described in clause 5.3.8 shall be carried out.

4.5.9 Internal immunity

4.5.9.1 Definition

Internal immunity is defined in CENELEC EN 50083-2 [1], clause 4.5.

4.5.9.2 Limits

The limits given in CENELEC EN 50083-2 [1], clause 4.5.2 shall be applied.

NOTE: This is subject to review and a new work item is being considered.

4.5.9.3 Conformance

Conformance tests described in clause 5.3.9 shall be carried out.

4.5.10 RF Connectors

The recommended connector for amplifiers is the female F-type connector (IEC 61169-24 [i.7]). For active antennas, either the IEC 61169-24 [i.7] or IEC 61169-2 [i.8] connectors of either sex may be used, but the former is preferred.

5 Testing for compliance with technical requirements

5.1 Environmental conditions for testing

Tests defined in the present document shall be carried out at representative points within the boundary limits of the declared operational environmental profile.

Where technical performance varies subject to environmental conditions, tests shall be carried out under a sufficient variety of environmental conditions (within the boundary limits of the declared operational environmental profile) to give confidence of compliance for the affected technical requirements.

5.2 Interpretation of the measurement results

The interpretation of the results recorded in a test report for the measurements described in the present document shall be as follows:

- the measured value related to the corresponding limit shall be used to decide whether an equipment meets the requirements of the present document;
- the value of the measurement uncertainty for the measurement of each parameter shall be included in the test report;
- the recorded value of the measurement uncertainty shall be, for each measurement, equal to or less than the figures in table 13.

For the test methods, according to the present document, the measurement uncertainty figures shall be calculated and shall correspond to an expansion factor (coverage factor) $k = 1,96$ or $k = 2$ (which provide confidence levels of respectively 95 % and 95,45 % in the case where the distributions characterizing the actual measurement uncertainties are normal (Gaussian)). Principles for the calculation of measurement uncertainty are contained in ETSI TR 100 028 [i.6].

Table 16 is based on such expansion factors.

Table 16: Maximum measurement uncertainty

Parameter	Uncertainty
RF frequency	$< \pm 1 \times 10^{-5}$
Radiated RF power	$< \pm 6$ dB
Conducted RF power variations using a test fixture	$< \pm 0,75$ dB

5.3 Methods of measurement

5.3.1 Amplifier gain

The measurement shall be made either with a network analyser or a spectrum analyser equipped with an RF tracking generator (figure 5). The output level of the tracking generator shall be set to an appropriate power level to avoid saturation and connected to the input port of the AUT.

If the gain can be varied, the test shall be carried out at the maximum gain of the amplifier. For amplifiers fitted with slope controls, the slope should be set to the flat position.

The amplifier gain in the log domain, g (dB), is defined by:

$$g(\text{dB}) = 10 \times \log_{10}(P_{out}/P_{in})$$

where P_{out} is the output power and P_{in} is the input power measured in the linear domain (W).

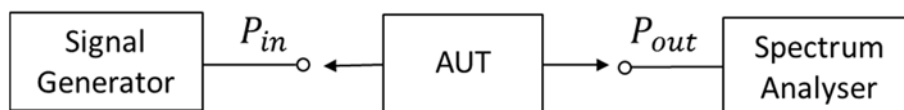

Figure 5: Measurement arrangement for amplifier gain test

The gain variation is defined as the difference between the maximum and minimum gain measured over the specified test frequencies.

5.3.2 Noise figure

The noise figure shall be measured with a calibrated noise generator operating in the frequency band of use for the AUT together with either a spectrum analyser or an automatic noise figure instrument. A noise figure instrument, if available, automates the process and replaces the spectrum analyser.

The measurement method is known as the "Y-Factor Method" and uses a noise generator with a calibrated Excess Noise Ratio (ENR). The ENR is defined as:

$$ENR_{dB} = 10 \times \log_{10} \left[\frac{T_s^{On} - T_s^{Off}}{T_0} \right]$$

where:

- T_s^{On} is the noise temperature of the noise source in its "on state";
- T_s^{Off} is the noise temperature of the noise source in its "off state"; and
- T_0 is the reference noise temperature (290 K).

The AUT shall be connected as shown in figure 6. The cable connection between the noise generator and the AUT should be kept as short as possible. The impedances of all test equipment should be adapted to that of the AUT with matching attenuators or transformers if required. Impedance transformers are preferable to matching attenuators to maintain the noise floor of the spectrum analyser.

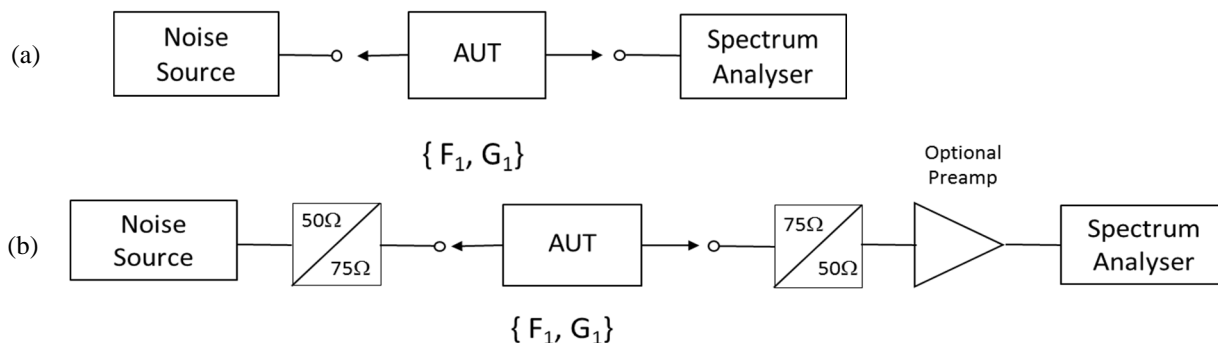

Figure 6: Measurement arrangements for noise figure test

The following measurement procedure shall be followed:

- 1) Set the spectrum analyser to a reference level appropriate for the AUT. Set the analyser to zero span, at the required test frequency. Set the detector to "rms" (for analysers that do not have an rms detector, the sample detector is recommended as an alternative), the sweep time to 20 seconds, the number measurement points to 501 (the number of measurement points cannot be altered on some analysers; alternatives to 501 may also be satisfactory dependent upon the analyser characteristics) the video bandwidth to 300 kHz (the video bandwidth setting is disabled on some analysers when the rms detector is selected), and the resolution bandwidth to 100 kHz to give a smooth trace with noise ripples < 0,25 dB. Set the spectrum analyser input attenuator to 0 dB and enable its pre-amplifier (where fitted).

- 2) Disconnect the AUT and terminate the input to the spectrum analyser with a 75 Ω load and record the displayed average noise level, p_{DANL} .

Reconnect the AUT and record the level in dBm of the amplified noise with the noise source in its off state, p_{off} . Calculate the noise corrected value, $p_{off,corr}$, using:

$$p_{off,corr} = 10 \times \log_{10} \left(10^{\left(\frac{p_{off}}{10}\right)} - 10^{\left(\frac{p_{DANL}}{10}\right)} \right)$$

- 3) Record the level of the amplified noise with the noise source in its on state, p_{on} . Calculate the noise corrected value, $p_{on,corr}$, using:

$$p_{on,corr} = 10 \times \log_{10} \left(10^{\left(\frac{p_{on}}{10}\right)} - 10^{\left(\frac{p_{DANL}}{10}\right)} \right)$$

- 4) Calculate the Y factor:

$$Y = 10^{((p_{on,corr} - p_{off,corr})/10)}$$

- 5) Calculate and record the value of the noise figure for the AUT thus:

$$nf = ENR_{dB} - 10 \times \log_{10}(Y - 1)$$

Repeat step 1) to step 5) at the specified test frequencies.

Other factors that may need to be considered to ensure accuracy include the loss associated with the impedance transformers and RF cables and the ENR value of the noise source. For further information, see application notes [i.2] and [i.3].

5.3.3 Amplifier intermodulation

Two equal amplitude, sinusoidal, non-harmonically related tones at ± 100 kHz from the required test frequency shall be injected by means of a combiner to the AUT input. The linearity of the signal generators and the combining arrangement should be checked on a spectrum analyser to ensure any third order intermodulation products in the generators are below -55 dBc.

The third order products shall be measured with a spectrum analyser as shown in figure 7 and figure 8.

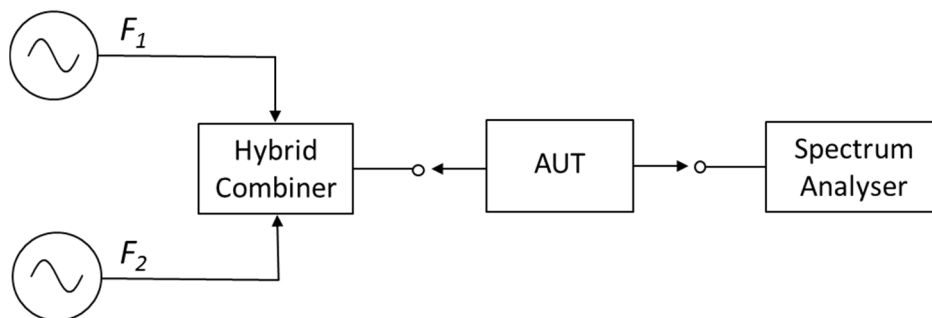

Figure 7: Measurement arrangement for intermodulation test

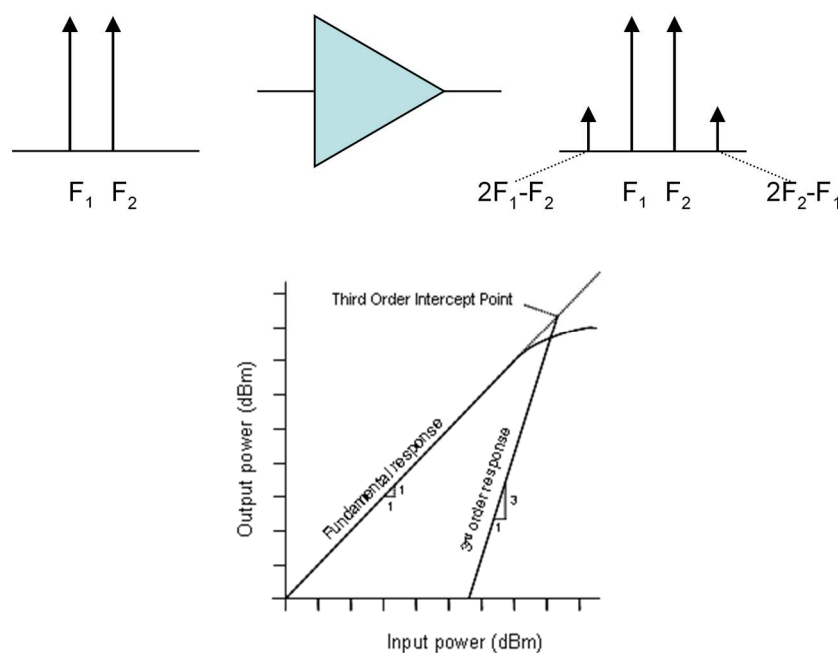

Figure 8: Third order IMD illustration

The level of each of the two tones shall be increased to a level p_{in} , until the larger of the two third order (IM3) products is between 38 dB and 42 dB below that of the wanted two tones at the output. The relative level of the worst product (IM3) shall be recorded.

The input referred, third order intercept (TOI) expressed in the log domain is given by:

$$TOI_{input} = p_{in} + \frac{IM3}{2}$$

where:

p_{in} is the level of each tone at the amplifier input expressed in dBm;

$IM3$ is the measured relative level of the worst third order intermodulation product, i.e. between 38 dBc and 42 dBc.

For variable gain amplifiers, the gain should be set to maximum. For amplifiers fitted with slope controls, the slope should be set to the flat position.

The test shall be repeated at the specified test frequencies.

5.3.4 Return loss

Return loss shall be measured with a network analyser, which should be calibrated to account for coupler directivity and cable loss (figure 9 (a)). As an alternative it may also be measured with a spectrum analyser equipped with a tracking generator using an external SWR bridge (figure 9 (b)), but calibration is generally more difficult.

The network analyser source power (or spectrum analyser tracking generator level) should be chosen to prevent saturation of the AUT. Precision RF adaptors and cable assemblies, designed for constant impedance, should be used to minimize degradation of the measured return loss.

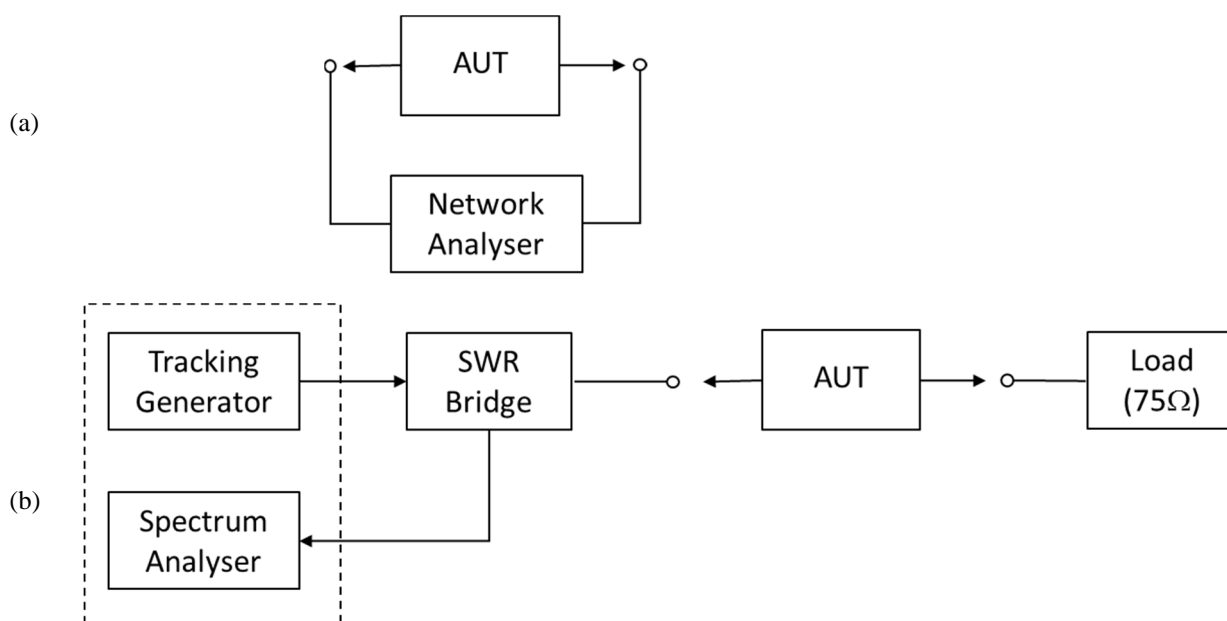

Figure 9: Return loss measurement arrangements using either a network analyser (a) or a spectrum analyser and an external bridge (b)

5.3.5 Selectivity

The selectivity measurement shall be made with a network analyser or a spectrum analyser equipped with an RF tracking generator as shown in figure 10. The output level of the tracking generator is set at an appropriate power level and connected to the input port of the A.U.T. The gain shall be measured across the specified frequency range.

If the amplifier gain can be varied, the test shall be carried out at the maximum gain. For amplifiers fitted with slope controls, the slope should be set to the flat position.

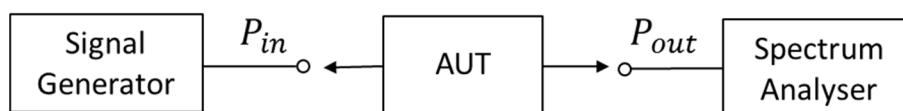

Figure 10: Amplifier frequency response measurement test arrangement

The amplifier gain in the log domain, $g(dB)$, is defined by:

$$g(f) = 10 \times \log_{10}(P_{out}/P_{in})$$

where:

P_{out} is the output power; and

P_{in} is the input power measured in the linear domain (W).

The measured frequency response shall meet the specified selectivity template.

5.3.6 Active antenna gain

This shall be measured using a GTEM cell as shown in figure 11.

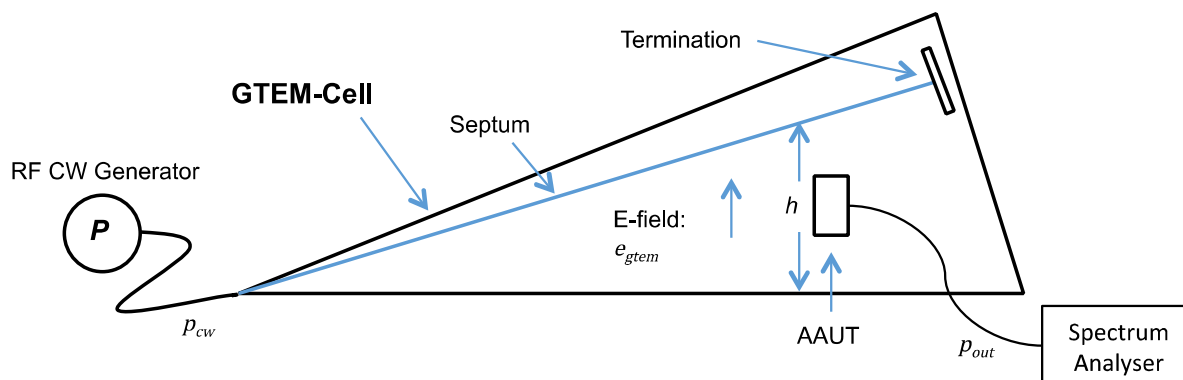

Figure 11: Active antenna gain test arrangement

The active antenna under test (AAUT) should be positioned at the optimum location within the GTEM cell, as specified by the cell manufacturer, taking into account the polarization of the generated field and the directivity of the AAUT. For variable gain AAUTs the gain shall be set to maximum.

Connections between the AAUT and the outside world shall be arranged to avoid common-mode effects and the ingress of interference. Common mode effects can be reduced by placing the AAUT on the floor of the GTEM cell, but the calibration of the GTEM cell will need to be adjusted to account for this.

The electric field, e_{gtem} , expressed in dB μ V/m seen by the AAUT shall be derived from the input power to the GTEM cell, p_{cw} , expressed in dBm using the relevant calibration data (see annex B). The gain of the AAUT is given by:

$$g_{aaut} = (g_i + g_a) = 77,2 + 20 \times \log_{10}(f_{MHz}) + p_{out,cw} - e_{gtem,cw}$$

where:

$p_{out,cw}$ is the output power in dBm at the output port of the AAUT;

$e_{gtem,cw}$ is the electric field in dB μ V/m seen by the AAUT within the GTEM cell.

An electric field, $e_{gtem,cw} = 70$ dB μ V/m shall be used for the tests.

5.3.7 Active antenna figure of merit

The antenna gain, g_{aaut} , at the specified test frequencies shall first be measured using the method described in clause 5.3.6.

With the AAUT in a GTEM cell with no RF signal applied, the noise power, p_n , delivered to the spectrum analyser by the AAUT shall be measured in an 8 MHz bandwidth with a spectrum analyser using the channel power measurement function.

The figure of merit (FoM) for the AAUT shall be calculated using:

$$FoM = (g_i - f_a) = -105 - p_n + g_{aaut}$$

The measurements shall be repeated at the specified test frequencies.

5.3.8 Active antenna intermodulation

The active antenna should be positioned in the GTEM cell as shown in figure 12.

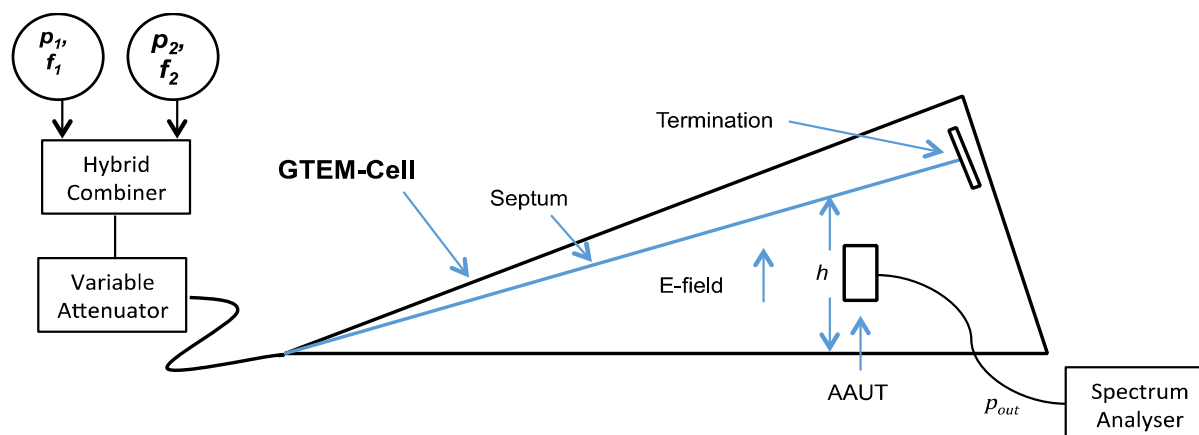

Figure 12: Active antenna intermodulation test arrangement

Two equal amplitude, sinusoidal, non-harmonically related tones at ± 100 kHz from the required test frequency shall be injected by means of a combiner to the AAUT as shown in figure 12. Note the linearity of the signal generators and the combining arrangement should be checked on a spectrum analyser to ensure any third order intermodulation products from the generators are below -55 dBc.

The third order products on the output signal, p_{out} , are measured, with a spectrum analyser.

The level of each of two tones shall be increased using the variable attenuator until the larger of the two third order (IM3) products measured on the spectrum analyser is between 38 dB and 42 dB below the wanted two tones at the output.

The input referred, third order intercept (TOI) expressed in the log domain is given by:

$$e_{toi} = p_{out} + \frac{IM3}{2} + (77,2 + 20 \times \log_{10}(f_{MHz}) - g_{aaut})$$

where:

p_{out} is the level of each of the tone at the amplifier input expressed in dBm;

$IM3$ is the measured level of the worst third order intermodulation product, i.e. between 38 dBc and 42 dBc;

f_{MHz} is the centre frequency of the two tones in MHz used for the test;

g_{aaut} is the active antenna gain measured using the procedure in clause 5.3.6.

The measurement shall be repeated for each of the specified test frequencies.

The calibration of the GTEM cell is not important for this measurement as the calibrated gain measurement, g_{aaut} , is used to calculate the input intercept from the measured output intercept ($p_{out} + \frac{IM3}{2}$). It is sometimes useful to place the AAUT above the septum of the GTEM cell to reduce the level of the signal required from the signal generators.

5.3.9 Internal immunity

5.3.9.1 Method of measurement

The internal immunity test shall be applied using the CENELEC EN 50083-2 [1] standard method.

Annex A (informative): Relationship between the present document and the essential requirements of Directive 2014/53/EU

The present document has been prepared under the Commission's standardisation request C(2015) 5376 final [i.4] to provide one voluntary means of conforming to the essential requirements of Directive 2014/53/EU on the harmonisation of the laws of the Member States relating to the making available on the market of radio equipment and repealing Directive 1999/5/EC [i.1].

Once the present document is cited in the Official Journal of the European Union under that Directive, compliance with the normative clauses of the present document given in table A.1 confers, within the limits of the scope of the present document, a presumption of conformity with the corresponding essential requirements of that Directive, and associated EFTA regulations.

Table A.1: Correspondence between the present document requirements and the essential requirements of Directive 2014/53/EU

Harmonised Standard ETSI EN 303 354				
Requirement			Requirement Conditionality	
No	Description	Reference: Clause(s) No	U/C	Condition
1	Gain	4.5.1	C	Amplifier requirement (category {P, D, L})
2	Noise figure	4.5.2	C	Amplifier requirement (category {P, D, L})
3	Amplifier intermodulation	4.5.3	C	Amplifier requirement (category {P, D, L})
4	Return loss	4.5.4	C	Amplifier requirement (category {P, D, L})
5	Selectivity classifications	4.5.5	C	Equipment category {A,P,D,L}{1,2}
6	Active antenna gain	4.5.6	C	Antenna specification (category {A})
7	Active antenna figure of merit	4.5.7	C	Antenna specification (category {A})
8	Active antenna intermodulation	4.5.8	C	Antenna specification (category {A})
9	Internal immunity	4.5.9	C	Amplifier requirement (category {P, D, L})
10	Unwanted emissions in the spurious domain	4.5.10	U	

Key to columns:

Requirement:

No A unique identifier for one row of the table which may be used to identify a requirement.

Description A textual reference to the requirement.

Clause Number Identification of clause(s) defining the requirement in the present document unless another document is referenced explicitly.

Requirement Conditionality:

U/C Indicates whether the requirement is unconditionally applicable (U) or is conditional upon the manufacturers claimed functionality of the equipment (C).

Condition Explains the conditions when the requirement is or is not applicable for a requirement which is classified "conditional".

Presumption of conformity stays valid only as long as a reference to the present document is maintained in the list published in the Official Journal of the European Union. Users of the present document should consult frequently the latest list published in the Official Journal of the European Union.

Other Union legislation may be applicable to the product(s) falling within the scope of the present document.

Annex B (informative): Active Antenna Theory

Consider an active antenna comprising a passive antenna with gain G_i relative to an isotropic radiator connected to an amplifier with a noise factor F_a and a gain G_a (all quantities in the linear domain).

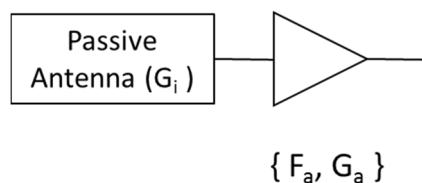

The antenna aperture, A_e , is given by [i.5]:

$$A_e = G_i \times \frac{\lambda^2}{4\pi}$$

And the power, P , delivered by the active antenna illuminated by an electric field E (V/m) is given by:

$$P = \frac{E^2}{Z_0} \times A_e \times G_a = \frac{E^2}{377} \times \frac{\lambda^2}{4\pi} \times G_i \times G_a = \frac{E^2 \lambda^2}{1\,508 \times \pi} \times G_i \times G_a = \frac{E^2 c^2}{1\,508 \times \pi \times f^2} \times G_i \times G_a$$

where:

Z_0 is the impedance of free space (nominally 377 Ω);

E is the incident electric field (V/m);

λ is the wavelength of the incident electric field (m);

c is the speed of light in free space ($2,998 \times 10^8$ m/s);

f is the frequency (Hz).

Note all quantities are measured in the linear domain. Converting to the log (dB) domain:

$$p_{dBW} = 10 \times \log_{10} \left(\frac{c^2}{1\,508 \times \pi} \right) + 20 \times \log_{10}(E) - 20 \times \log_{10}(f) + 10 \times \log_{10}(G_i) + 10 \times \log_{10}(G_a)$$

$$p_{dBW} = 10 \times \log_{10} \left(\frac{c^2}{1\,508 \times \pi} \right) + \frac{e_{dBV}}{m} - 20 \times \log_{10}(f) + g_i + g_a$$

where:

p_{dBW} is the power delivered by the antenna in dB relative to 1 W;

$e_{dBV/m}$ is the incident electric field in dB relative to (1 V/m);

g_i is the antenna gain in the log domain relative to an isotropic antenna (dBi);

g_a is the amplifier gain in the log domain (dB).

Scaling to power relative to 1 mW, p_{dBm} , at a frequency, f_{MHz} , for an electric field, $e_{dB\mu V/m}$ gives:

$$p_{dBm} = -30 + 10 \times \log_{10} \left(\frac{c^2}{1\,508 \times \pi} \right) + \left(\frac{e_{dB\mu V}}{m} - 120 \right) - (120 + 20 \times \log_{10}(f_{MHz})) + g_i + g_a$$

$$p_{dBm} = \left\{ 10 \times \log_{10} \left(\frac{c^2}{1\,508 \times \pi} \right) - 210 \right\} + e_{dB\mu V/m} - 20 \times \log_{10}(f_{MHz}) + g_i + g_a$$

$$p_{dBm} = -77,2 + e_{dB\mu V/m} - 20 \times \log_{10}(f_{MHz}) + g_i + g_a$$

The active antenna gain, g_{aaut} , can thus be calculated from the output power, p_{dBm} , from an AAUT illuminated by a known electric field, $e_{dB\mu V/m}$, using:

$$g_{aaut} = g_i + g_a = p_{dBm} + 77,2 - e_{dB\mu V/m} + 20 \times \log_{10}(f_{MHz})$$

A useful figure of merit (FoM) for an active antenna is the passive antenna gain, g_i , less the amplifier noise figure f_a . Increasing the passive gain, g_i , or decreasing the noise figure, f_a , will improve reception in a typical application.

The power, P_N , in mW, delivered by an active antenna in a GTEM cell with no E field applied measured in a bandwidth of B_{MHz} is given by:

$$P_N = 1\,000 \times G_a F_a k T B_{MHz}$$

Converting to the log domain (dB), the power referenced to 1 mw, $p_{n,dBm}$, is given by:

$$p_{n,dBm} = g_a + f_a + 10 \times \log_{10}(kT) + 10 \times \log_{10}(B_{MHz}) + 30$$

$$p_{n,dBm} = g_a + f_a + 10 \times \log_{10}(B_{MHz}) - 114$$

Substituting:

$$g_a = g_{aaut} - g_i$$

Gives:

$$p_{n,dBm} = g_{aaut} - g_i + f_a + 10 \times \log_{10}(B_{MHz}) - 114$$

Rearranging this equation allows the antenna figure of merit, FoM , to be calculated from the active antenna gain and the noise power delivered by an unilluminated antenna:

$$FoM = (g_i - f_a) = -114 + 10 \times \log_{10}(B_{MHz}) - p_{n,dBm} + g_{aaut}$$

Annex C (informative): Change History

Version	Information about changes
V1.1.1	First published version.

History

Document history				
V1.0.2	June 2016	EN Approval Procedure	AP 20160913:	2016-06-15 to 2016-09-13
V1.1.0	November 2016	Vote	V 20170120:	2016-11-21 to 2017-01-20