



EUROPEAN STANDARD

**Broadcast Sound Receivers;
Part 1: Generic requirements and measuring methods**

ReferenceDEN/ERM-TG17-151

Keywordsbroadcast, digital, radio, receiver

ETSI

650 Route des Lucioles
F-06921 Sophia Antipolis Cedex - FRANCE

Tel.: +33 4 92 94 42 00 Fax: +33 4 93 65 47 16

Siret N° 348 623 562 00017 - NAF 742 C
Association à but non lucratif enregistrée à la
Sous-Préfecture de Grasse (06) N° 7803/88

Important notice

The present document can be downloaded from:

<http://www.etsi.org/standards-search>

The present document may be made available in electronic versions and/or in print. The content of any electronic and/or print versions of the present document shall not be modified without the prior written authorization of ETSI. In case of any existing or perceived difference in contents between such versions and/or in print, the prevailing version of an ETSI deliverable is the one made publicly available in PDF format at www.etsi.org/deliver.

Users of the present document should be aware that the document may be subject to revision or change of status.

Information on the current status of this and other ETSI documents is available at

<https://portal.etsi.org/TB/ETSIDeliverableStatus.aspx>

If you find errors in the present document, please send your comment to one of the following services:

<https://portal.etsi.org/People/CommiteeSupportStaff.aspx>

Copyright Notification

No part may be reproduced or utilized in any form or by any means, electronic or mechanical, including photocopying and microfilm except as authorized by written permission of ETSI.

The content of the PDF version shall not be modified without the written authorization of ETSI.

The copyright and the foregoing restriction extend to reproduction in all media.

© ETSI 2019.

All rights reserved.

DECT™, **PLUGTESTS™**, **UMTS™** and the ETSI logo are trademarks of ETSI registered for the benefit of its Members.

3GPP™ and **LTE™** are trademarks of ETSI registered for the benefit of its Members and of the 3GPP Organizational Partners.

oneM2M™ logo is a trademark of ETSI registered for the benefit of its Members and of the oneM2M Partners.

GSM® and the GSM logo are trademarks registered and owned by the GSM Association.

Contents

Intellectual Property Rights	4
Foreword.....	4
Modal verbs terminology.....	5
1 Scope	6
2 References	6
2.1 Normative references	6
2.2 Informative references.....	6
3 Definition of terms, symbols and abbreviations.....	7
3.1 Terms.....	7
3.2 Symbols.....	7
3.3 Abbreviations	7
4 Technical requirements specifications	8
4.1 Environmental profile.....	8
4.2 Conformance requirements	8
4.2.1 Broadcast radio modulation methods.....	8
4.2.2 Broadcast radio frequency bands	8
5 Testing for compliance with technical requirements.....	9
5.1 Environmental conditions for testing	9
5.2 Interpretation of the measurement results	9
5.3 Methods of measurement	9
5.3.1 Generic methods of measurement.....	9
5.3.2 Generic measurement set-up for radiated testing.....	10
5.3.3 Generic measurement set-up for conducted testing	13
5.3.4 Sensitivity measurement methods.....	14
5.3.4.1 Analogue (AM and FM) sensitivity measurements.....	14
5.3.4.2 Digital (DAB and DRM) sensitivity measurements.....	14
5.3.5 Adjacent channel selectivity and blocking measurement methods	14
5.3.5.1 Analogue (AM and FM) adjacent channel selectivity and blocking measurements	14
5.3.5.2 Digital (DAB and DRM) adjacent channel selectivity and blocking measurements.....	15
Annex A (informative): A fibre-optic link for receiver testing.....	16
Annex B (informative): Measurement set-up for electrical methods during radiated testing	18
Annex C (informative): Change History	19
History	20

Intellectual Property Rights

Essential patents

IPRs essential or potentially essential to normative deliverables may have been declared to ETSI. The information pertaining to these essential IPRs, if any, is publicly available for **ETSI members and non-members**, and can be found in ETSI SR 000 314: "*Intellectual Property Rights (IPRs); Essential, or potentially Essential, IPRs notified to ETSI in respect of ETSI standards*", which is available from the ETSI Secretariat. Latest updates are available on the ETSI Web server (<https://ipr.etsi.org/>).

Pursuant to the ETSI IPR Policy, no investigation, including IPR searches, has been carried out by ETSI. No guarantee can be given as to the existence of other IPRs not referenced in ETSI SR 000 314 (or the updates on the ETSI Web server) which are, or may be, or may become, essential to the present document.

Trademarks

The present document may include trademarks and/or tradenames which are asserted and/or registered by their owners. ETSI claims no ownership of these except for any which are indicated as being the property of ETSI, and conveys no right to use or reproduce any trademark and/or tradename. Mention of those trademarks in the present document does not constitute an endorsement by ETSI of products, services or organizations associated with those trademarks.

Foreword

This final draft European Standard (EN) has been produced by ETSI Technical Committee Electromagnetic compatibility and Radio spectrum Matters (ERM), and is now submitted for the Vote phase of the ETSI standards EN Approval Procedure.

The present document is part 1 of a multi-part deliverable covering the requirements and measuring methods for broadcast sound receivers to meet the essential requirements of article 3.2 of Directive 2014/53/EU [i.1], as identified below:

Part 1: "Generic requirements and measuring methods";

Part 2: "AM broadcast sound service";

Part 3: "FM broadcast sound service";

Part 4: "DAB broadcast sound service";

Part 5: "DRM broadcast sound service".

The test data files are contained in archive en_30334501v010101v0.zip which accompanies the present document.

Proposed national transposition dates	
Date of latest announcement of this EN (doa):	3 months after ETSI publication
Date of latest publication of new National Standard or endorsement of this EN (dop/e):	6 months after doa
Date of withdrawal of any conflicting National Standard (dow):	18 months after doa

Modal verbs terminology

In the present document "**shall**", "**shall not**", "**should**", "**should not**", "**may**", "**need not**", "**will**", "**will not**", "**can**" and "**cannot**" are to be interpreted as described in clause 3.2 of the [ETSI Drafting Rules](#) (Verbal forms for the expression of provisions).

"**must**" and "**must not**" are **NOT** allowed in ETSI deliverables except when used in direct citation.

1 Scope

The present document specifies generic requirements and methods of measurements for devices, including the supplied antenna, that receive broadcast sound services, whether analogue or digital modulation is used to meet the essential requirements of article 3.2 of Directive 2014/53/EU [i.1]. Subsequent parts of this multi-part deliverable provide the necessary test signal configurations and limits for the different broadcast sound services. Multi-function devices may also fall under the requirements of other documents.

2 References

2.1 Normative references

References are either specific (identified by date of publication and/or edition number or version number) or non-specific. For specific references, only the cited version applies. For non-specific references, the latest version of the referenced document (including any amendments) applies.

Referenced documents which are not found to be publicly available in the expected location might be found at <https://docbox.etsi.org/Reference/>.

NOTE: While any hyperlinks included in this clause were valid at the time of publication, ETSI cannot guarantee their long term validity.

The following referenced documents are necessary for the application of the present document.

- [1] CENELEC EN 55032:2015: "Electromagnetic compatibility of multimedia equipment - Emission Requirements".
- [2] IEC 60315-1 (1988): "Methods of measurement on radio receivers for various classes of emission. Part 1: General considerations and methods of measurement, including audio-frequency measurements".
- [3] Recommendation ITU-R BS.468-4 (07/1986): "Measurement of audio-frequency noise voltage level in sound broadcasting".

2.2 Informative references

References are either specific (identified by date of publication and/or edition number or version number) or non-specific. For specific references, only the cited version applies. For non-specific references, the latest version of the referenced document (including any amendments) applies.

NOTE: While any hyperlinks included in this clause were valid at the time of publication, ETSI cannot guarantee their long term validity.

The following referenced documents are not necessary for the application of the present document but they assist the user with regard to a particular subject area.

- [i.1] Directive 2014/53/EU of the European Parliament and of the Council of 16 April 2014 on the harmonisation of the laws of the Member States relating to the making available on the market of radio equipment and repealing Directive 1999/5/EC.
- [i.2] ETSI TR 100 028 (all parts): "Electromagnetic compatibility and Radio spectrum Matters (ERM); Uncertainties in the measurement of mobile radio equipment characteristics".
- [i.3] ETSI TR 100 028-2: "Electromagnetic compatibility and Radio spectrum Matters (ERM); Uncertainties in the measurement of mobile radio equipment characteristics; Part 2".
- [i.4] ECA table in ERC report 25.

NOTE: Available at www.efis.dk.

- [i.5] CISPR 35: "Electromagnetic Compatibility of Multimedia equipment - Immunity Requirements".
- [i.6] BBC Research & Development White Paper WHP 335: "A Fibre-Optic Link for Use During Receiver Testing".

NOTE: Available at <http://downloads.bbc.co.uk/rd/pubs/whp/whp-pdf-files/WHP335.pdf>.

3 Definition of terms, symbols and abbreviations

3.1 Terms

For the purposes of the present document, the terms given in Directive 2014/53/EU [i.1] and the following apply:

adjacent channel selectivity: at a given frequency separation, ratio of the maximum unwanted signal level to the wanted signal level necessary to provide a given level of audio quality

blocking: at a given frequency separation, ratio of the maximum AM unwanted signal level to the wanted signal level necessary to provide a given level of audio quality

built-in antenna: antenna that cannot be detached from the equipment

dBm: decibels relative to 1 mW of power

external antenna: antenna designed to be connected to the equipment with the use of a 50 Ω or 75 Ω external connector

integral antenna: antenna which is detachable from the equipment without the use of any tools, and not using a 50 Ω or 75 Ω external connector

NOTE: A device that uses a supplied earphone as the antenna has an integral antenna.

sensitivity: minimum wanted signal level required to provide a given level of audio quality

3.2 Symbols

Void.

3.3 Abbreviations

For the purposes of the present document, the following abbreviations apply:

AM	Amplitude Modulation
AMSS	Amplitude Modulation Signalling System
BBC	British Broadcasting Corporation
BS	Broadcast service (Sound)
CISPR	Comité International Spécial des Perturbations Radioélectriques
CMAD	Common Mode Absorption Device
DAB	Digital Audio Broadcasting
DRM	Digital Radio Mondiale
EC	European Commission
ECA	European Common Allocation
EU	European Union
FAR	Fully Anechoic Room
FM	Frequency Modulation
GTEM	Gigahertz Transverse ElectroMagnetic
HF	High Frequency
IEC	International Electrotechnical Commission
ITU-R	International Telecommunications Union - Radiocommunications
LED	Light Emitting Diode

LF	Low Frequency
MF	Medium Frequency
RDS	Radio Data System
RF	Radio Frequency
RUT	Receiver Under Test
S/PDIF	Sony/Philips Digital InterFace
SAC	Semi Anechoic Chamber
THD	Total Harmonic Distortion
THD+N	Total Harmonic Distortion plus Noise
UI	User Interface
VHF	Very High Frequency

4 Technical requirements specifications

4.1 Environmental profile

The technical requirements of the present document apply under the environmental profile for operation of the equipment, which shall be declared by the manufacturer.

4.2 Conformance requirements

4.2.1 Broadcast radio modulation methods

The following broadcast radio modulation methods are considered feasible within the current authorization regime in Europe:

- Amplitude modulation, with or without AMSS (AM).
- Frequency modulation, with or without RDS (FM).
- Digital Audio Broadcasting (DAB).
- Digital Radio Mondiale (DRM).

Broadcast radio receivers may include demodulation capability for one or more of these modulation methods. Conformance shall only be required for each of the modulation methods included in the receiver.

4.2.2 Broadcast radio frequency bands

The following frequency bands are identified in the ECA table [i.4] for broadcast radio services:

- Low frequency (LF): 148,5 kHz to 283,5 kHz.
- Medium frequency (MF): 526,5 kHz to 1 606,5 kHz.
- High Frequency (HF): 3 950 kHz to 4 000 kHz, 5 900 kHz to 6 200 kHz, 7 200 kHz to 7 450 kHz, 9 400 kHz to 9 900 kHz, 11 600 kHz to 12 100 kHz, 13 570 kHz to 13 870 kHz, 15 100 kHz to 15 800 kHz, 17 480 kHz to 17 900 kHz, 18 900 kHz to 19 020 kHz, 21 450 kHz to 21 850 kHz and 25 670 kHz to 26 100 kHz.
- VHF band I: 47 MHz to 68 MHz.
- VHF band II: 87,5 MHz to 108 MHz.
- VHF band III: 174 MHz to 240 MHz.

Broadcast radio receivers may include tuning capability for one or more of these frequency bands. Conformance shall only be required for each of the frequency bands included in the receiver.

5 Testing for compliance with technical requirements

5.1 Environmental conditions for testing

The equipment shall be tested under normal test conditions according to the relevant product and basic standards or to the information accompanying the equipment, which are within the manufacturers declared range of humidity, temperature and supply voltage. The test conditions shall be recorded in the test report.

5.2 Interpretation of the measurement results

The interpretation of the results recorded in a test report for the measurements described in the present document shall be as follows:

- the measured value related to the corresponding limit will be used to decide whether an equipment meets the requirements of the present document;
- the value of the measurement uncertainty for the measurement of each parameter shall be included in the test report;
- the recorded value of the measurement uncertainty shall be, for each measurement, equal to or less than the figures in table 1.

For the test methods, according to the present document, the measurement uncertainty figures shall be calculated and shall correspond to an expansion factor (coverage factor) $k = 1,96$ or $k = 2$ (which provide confidence levels of respectively 95 % and 95,45 % in the case where the distributions characterizing the actual measurement uncertainties are normal (Gaussian)). Principles for the calculation of measurement uncertainty are contained in ETSI TR 100 028 [i.2], in particular in annex D of the ETSI TR 100 028-2 [i.3].

Table 1 is based on such expansion factors.

Table 1: Maximum measurement uncertainty

Parameter	Uncertainty
Uncertainty in conducted measurements	± 1 dB
Uncertainty in radiated measurements	± 6 dB

5.3 Methods of measurement

5.3.1 Generic methods of measurement

Two generic methods of measurement are applicable to verifying the performance of the receiving equipment in question. The conducted test methods shall be used for receivers with an external antenna connector. The radiated test methods shall be used for all other receivers.

For both generic methods, two generators are needed. One provides the wanted signal, and the other the unwanted signal, or interferer (when required). The two signals are combined in such a way as to maintain isolation between the generators. It is necessary to provide calibrated attenuators for control of the individual levels; very often these will be built into the generators. Where the attenuators are external, cable lengths should be kept short to avoid cross-coupling effects.

The tests require the audio output of the receiver to be measured. All tonal controls (user operated and/or preset, for example, vehicle specific equaliser, etc.) shall be set to provide a flat response during the testing. The measurement device for the different modulation methods is given in table 2.

Table 2: Measurement device requirements

Modulation method	Measurement device on audio output
Analogue (AM and FM)	quasi-peak detector employing Recommendation ITU-R BS.468-4 [3], clause 1 weighting
Digital (DAB and DRM)	none (listen to audio)

5.3.2 Generic measurement set-up for radiated testing

The measurement set-up is shown in figure 1 where © represents the calibration point of the system.

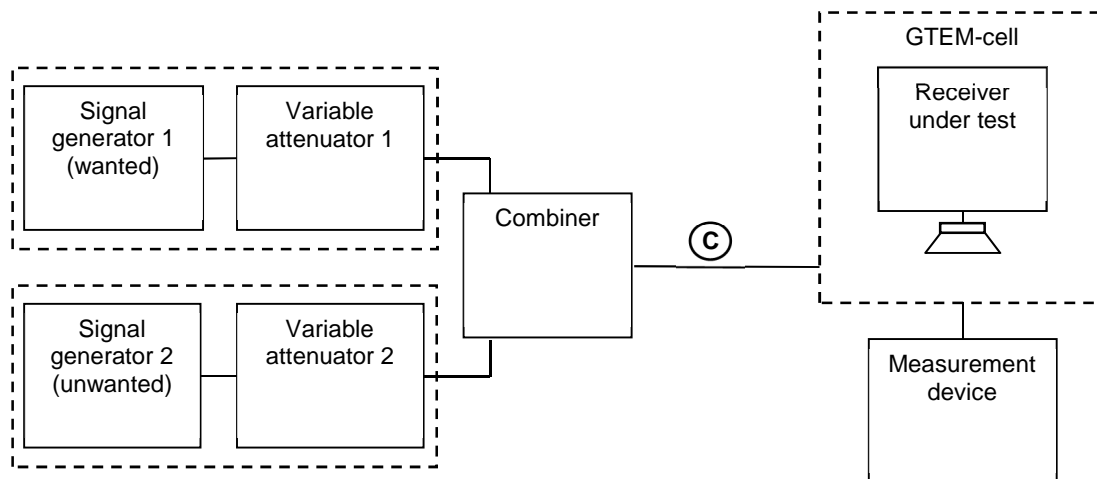

Figure 1: Generic measurement arrangement for receivers with built-in or integral antennas

The combiner shall be appropriate for the frequency range of the testing and shall be designed so as to prevent coupling between the two signal generators. Some test houses have experienced difficulties using hybrid combining networks at LF and MF. In such cases a resistive combiner may be appropriate, but care should be taken to ensure the coupling between the generators does not result in unwanted intermodulation products. Hybrid combiners are available for use at LF and MF and these usually give better performance than resistive combining networks.

Signal generator 1 and signal generator 2 may be combined as a single item of test equipment. In this case either the RF signal or the baseband signal may be combined internally, as long as the signal at calibration point © is equivalent to the signal generated in the setup according to figure 1.

The power levels of the two generators are measured at ©. For a 50 Ω system, when the power at © is P W, the nominal field-strength E is given by:

$$\frac{\sqrt{50 \times P}}{h}$$

where h is the height of the cell's septum above its floor in metres. The exact relationship between P and E should be obtained from the manufacturer of the cell.

The GTEM cell shall be of sufficient dimensions to provide a uniform field with the antenna fully extended; a minimum floor to ceiling height of 2 m is recommended. Figure 2 shows the usable volume of the GTEM cell.

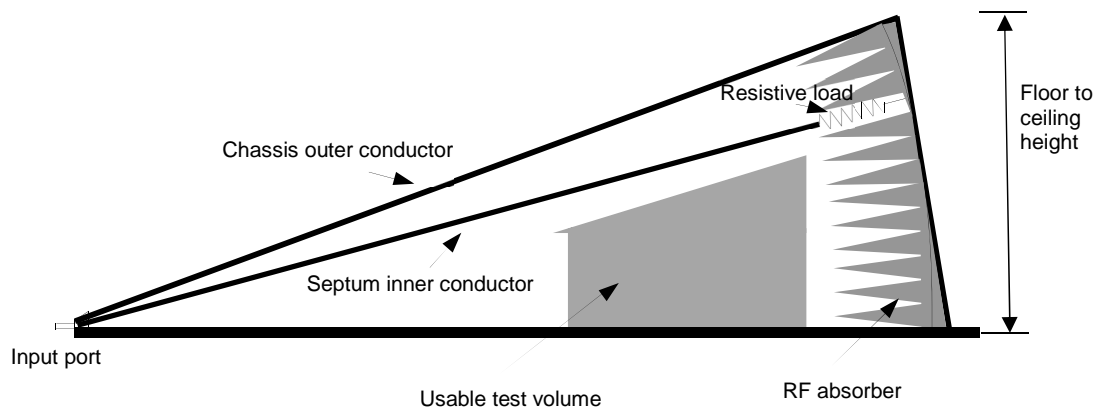

Figure 2: Side elevation of GTEM-cell showing usable test volume

Details of the positioning of the receiver under test within the GTEM-cell are shown in figure 3:

- If the receiver under test is capable of running on internal batteries, then the testing shall be performed with new batteries fitted and no connection made to any external power source; the receiver shall be placed in the centre of the usable volume. If the receiver under test can only be operated with mains power or another external power source, the receiver shall be placed as close to the floor as possible whilst remaining in the calibrated zone and the power connection shall be run vertically from the receiver to the floor and then along the floor of the cell.
- Receivers using an earphone as the integral antenna shall be placed close to the floor, but separated from it by a non-conducting spacer, and the earphone shall be attached to a non-conducting support which holds the earpieces 15 cm apart with the lead running vertically downwards to its full extent to connect to the receiver.
- Receivers using a wire antenna (typically clock radios) shall be placed in the measuring environment such that the wire is fully contained within the calibrated zone. This may require the wire to be supported on a non-conducting structure.
- Receivers with internal ferrite rod antennas shall be positioned such that the axis of the ferrite rod is perpendicular to the current flow in the septum and parallel to the plane of the septum, as shown in figure 3.

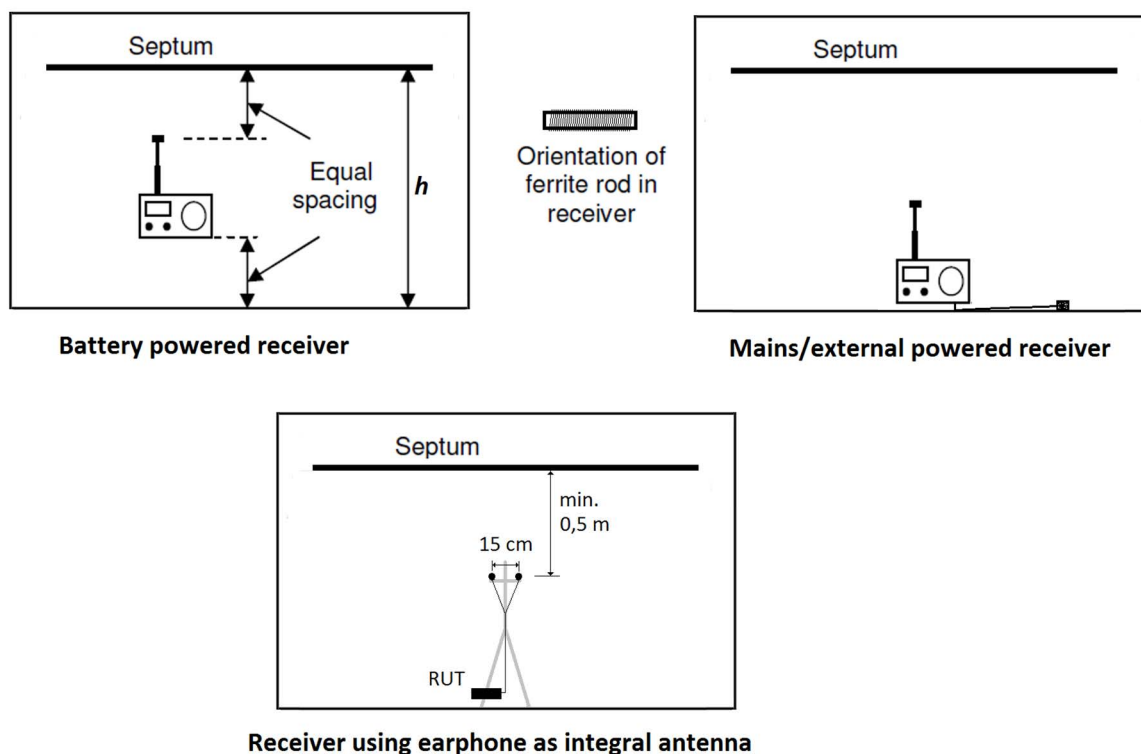

Figure 3: Diagram to show the positioning of receiver within GTEM-cell (viewed from input port)

Receivers which have a choice of antenna need not be tested for all antennas: in this case the results shall be recorded against each antenna that is used for the testing.

The measurement device, which shall be external to the GTEM-cell, shall be connected in such a way as to avoid either disturbance to the field within the cell or ingress of external interference. The following methods of connection for the audio output of the receiver to the external environment can be used:

- Optical.
- Acoustic: reference to CISPR 35 [i.5], annex G may be made for guidance on appropriate methods but the band pass filter specified in CISPR 35 [i.5], annex G shall not be used. For the analogue modulation methods it is important to characterize and compensate for the frequency transfer function of the acoustic network, because the audio test set is required to measure wide-band noise.

A Semi Anechoic Chamber (SAC) or Fully Anechoic Room (FAR) in compliance with CENELEC EN 55032 [1], table A.1, annex C and annex D may be used in place of a GTEM cell. In these environments, electrical connections from the receiver to the audio measurement device are permitted provided they can be shown not to disturb the electric field; ferrite cores and/or filters are required.

Where no earphone socket is provided, a manufacturer may extend the speaker leads from the internal speaker of the receiver to a local test port which shall then be connected to an optical link.

An alternative way of generating a known magnetic field for frequencies below 30 MHz is by means of a test-loop, typically a single turn of wire about 300 mm in diameter and possessing an internal termination. Loops vary, and the manufacturer's instructions should be followed. The test-loop shall be used in a screened environment. A further way of generating a known magnetic field is given in IEC 60315-1 [2], clause 12, clause 19, clause 20, clause 21, clause 22, appendix B and appendix C.

For products using an earphone as the antenna, an electrical method can be used if the audio signal is isolated from the RF field by using an adaptor to prevent antenna performance degradation. An example of such an adaptor is shown in figure 4.

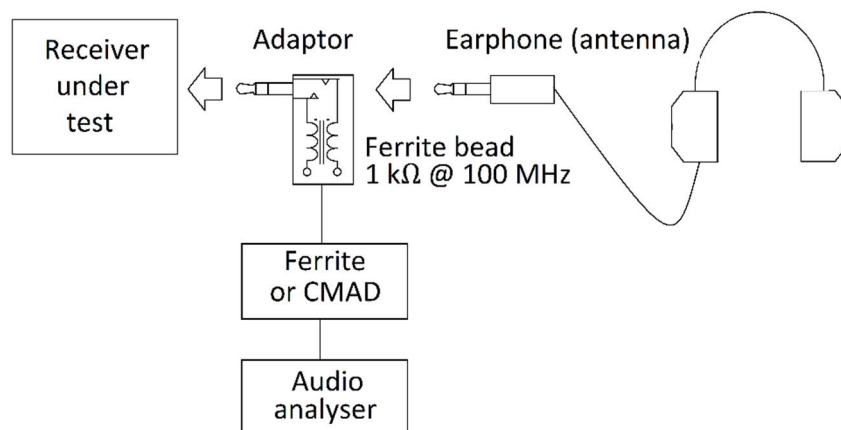

NOTE: The adaptor should be appropriate to the band being tested.

Figure 4: Example adaptor for products using earphone as antenna

5.3.3 Generic measurement set-up for conducted testing

The measurement set-up is shown in figure 5 where © represents the calibration point of the system. In this case, there is no need for careful screening from the external environment, although high field-strengths from potential interferers should be avoided.

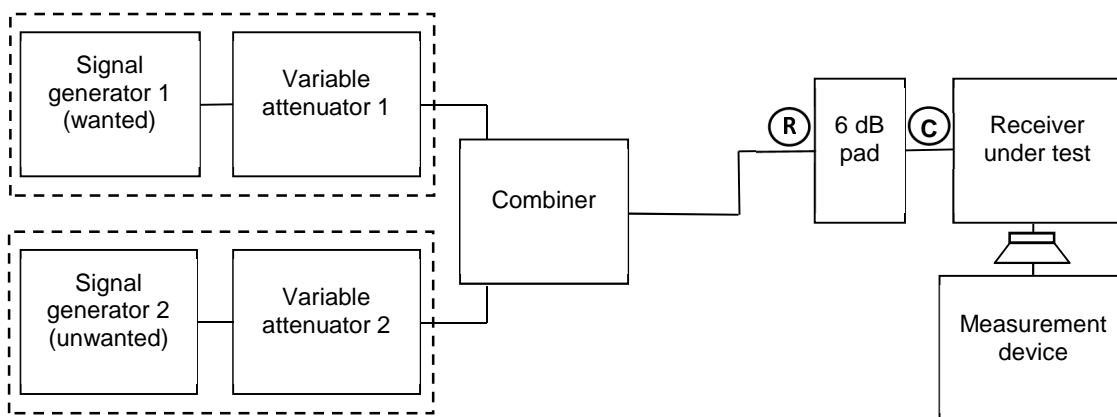

Figure 5: Generic measurement arrangement for receivers with an external antenna connector

The power levels of the two generators are measured at ©.

The power levels of the two generators are measured at ®, which is the input to the 6 dB pad. The power level at © is then calculated, accounting for the nominal 6 dB loss of the pad.

The combiner shall be appropriate for the frequency range of the testing and shall be designed so as to prevent coupling between the two signal generators. Some test houses have experienced difficulties using hybrid combining networks at LF and MF. In such cases a resistive combiner may be appropriate, but care should be taken to ensure the coupling between the generators does not result in unwanted intermodulation products. Hybrid combiners are available for use at LF and MF and these usually give better performance than resistive combining networks.

Signal generator 1 and signal generator 2 may be combined as a single item of test equipment. In this case either the RF signal or the baseband signal may be combined internally, as long as the signal at ® is equivalent to the signal generated in the setup according to figure 5.

The 6 dB pad shall be located on the receiver antenna port to minimize errors associated with poor return loss at the receiver tuner input. Most test equipment is designed for 50 Ω systems: automotive receivers have 50 Ω antenna ports, whereas domestic receivers usually have 75 Ω antenna ports. In the case of a 75 Ω antenna port, the 6 dB pad shall take the form of a minimum loss 50 Ω to 75 Ω matching pad. Care should be taken not to mix 50 Ω connectors and 75 Ω connectors, or damage could result.

For receivers which use an internal passive splitter to provide signals to multiple tuners and an active antenna which provides level matching, the power level at the calibration point shall be increased by the same factor as that provided by the active antenna (i.e. for the example of a receiver with an internal two-way 3 dB splitter and an active antenna providing a 3 dB gain, the power level at © shall be increased by 3 dB). This factor shall be specified in the test report.

5.3.4 Sensitivity measurement methods

5.3.4.1 Analogue (AM and FM) sensitivity measurements

- 1) The 'unwanted' signal generator remains switched off for the duration of the test.
- 2) The 'wanted' signal generator is set to the required modulation method, test signal configuration and centre frequency. The signal level is adjusted with the modulation disabled to the required sensitivity level plus 6 dB, as measured at ©. The modulation is enabled.
- 3) The receiver is tuned to the frequency of the 'wanted' signal generator. For a receiver without a digital frequency display, the receiver shall be tuned for optimum THD+N (i.e. as it would be tuned by a user for best quality). The receiver's audio level shall be set so as to provide clean 1 kHz audio tone at the audio output (minimum distortion, that is typically less than 3 % total harmonic distortion, but no more than 10 % total harmonic distortion) but of sufficient level to drive the measurement device.
- 4) The level of the 'wanted' signal generator is reduced by 6 dB.
- 5) The audio output, measured using the measurement device, is recorded as the signal level, S.
- 6) The modulating audio signal for the 'wanted' signal generator is removed. The audio output, measured using the measurement device, is recorded as the noise level, N.

NOTE: Modulation is disabled when setting the power level to prevent sideband power from influencing the measurement. Sideband power is not considered when measuring the power of analogue signals.

5.3.4.2 Digital (DAB and DRM) sensitivity measurements

- 1) The 'unwanted' signal generator remains switched off for the duration of the test.
- 2) The 'wanted' signal generator is set to the required modulation method, test signal configuration, and centre frequency. The signal level is adjusted to provide the required sensitivity level plus 30 dB, as measured at ©.
- 3) The receiver is tuned to the frequency of the 'wanted' signal generator and the required service is selected using the UI. The audio level shall be set so as to provide clean 1 kHz audio tone at the audio output (minimum distortion, that is typically less than 3 % total harmonic distortion, but no more than 10 % total harmonic distortion) but of sufficient level to drive the measurement device.
- 4) The level of the 'wanted' signal generator is reduced by 30 dB.

5.3.5 Adjacent channel selectivity and blocking measurement methods

5.3.5.1 Analogue (AM and FM) adjacent channel selectivity and blocking measurements

- 1) The 'wanted' signal generator is set to the required modulation method, test signal configuration, and centre frequency. The signal level is adjusted with the modulation disabled to the specified wanted signal level, as measured at ©, with the 'unwanted' generator switched off.

- 2) The 'unwanted' signal generator is set to the required modulation method, test signal configuration, and centre frequency calculated from the wanted signal centre frequency and the required frequency offset. The signal level is adjusted with the modulation disabled to provide the level calculated from the wanted signal level and the required level offset, as measured at ©, with the 'wanted' generator switched off.
- 3) The 'wanted' signal generator is switched back on. Modulation is enabled for both signal generators.
- 4) The receiver is tuned to the frequency of the 'wanted' signal generator. For a receiver without a digital frequency display, the receiver shall be tuned for optimum THD+N (i.e. as it would be tuned by a user for best quality). The receiver's audio level shall be set so as to provide clean 1 kHz audio tone at the audio output (minimum distortion, that is typically less than 3 % total harmonic distortion, but no more than 10 % total harmonic distortion) but of sufficient level to drive the measurement device.
- 5) The audio output, measured using the measurement device, is recorded as the signal level, S.
- 6) The modulating audio signal for the 'wanted' signal generator is removed. The audio output, measured using the measurement device, is recorded as the noise level, N.

NOTE: Modulation is disabled when setting the power levels to prevent sideband power from influencing the measurement. Sideband power is not considered when measuring the power of analogue signals.

5.3.5.2 Digital (DAB and DRM) adjacent channel selectivity and blocking measurements

- 1) The 'wanted' signal generator is set to the required modulation method, test configuration, and to the wanted centre frequency. The signal level is adjusted to the specified wanted signal level, as measured at ©, with the 'unwanted' generator switched off.
- 2) The receiver is tuned to the frequency of the 'wanted' signal generator. The audio level shall be set so as to provide clean 1 kHz audio tone at the audio output (minimum distortion, that is typically less than 3 % total harmonic distortion, but no more than 10 % total harmonic distortion) but of sufficient level to drive the measurement device.
- 3) The 'unwanted' signal generator is set to the required modulation method, test configuration, and centre frequency calculated from the wanted signal centre frequency and the required frequency offset. The signal level is adjusted to provide the level calculated from the wanted signal level and the required level offset, as measured at ©, with the 'wanted' generator switched off. For the blocking test only, the audio modulation of the 'unwanted' signal shall be removed whilst measuring the level at ©.
- 4) The 'wanted' signal generator is switched back on.

Annex A (informative): A fibre-optic link for receiver testing

Electrical connections within the electromagnetic field can influence the measurement results. There are two possible causes:

- The electrical connection can affect the antenna-earth system of the receiver-under-test (RUT).
- Electrical interference can travel along the cable and so reduce the apparent sensitivity of the RUT.

The electrical interconnection between the audio output of the RUT and the audio analyser can be eliminated by using an 'analogue' fibre-optic link. If the link transmitter is kept small, and directly connected to the RUT, the effect on the antenna-earth system is negligible. Since the fibre-optic cable is non-metallic, interference cannot be conducted along it. The 'analogue' implementation is important: digital links exist (e.g. S/PDIF, Bluetooth), but experiments have shown that these can generate significant interference to the measurements.

A simple optical transmitter can be based on a pulse-width modulator, as shown in figure A.1.

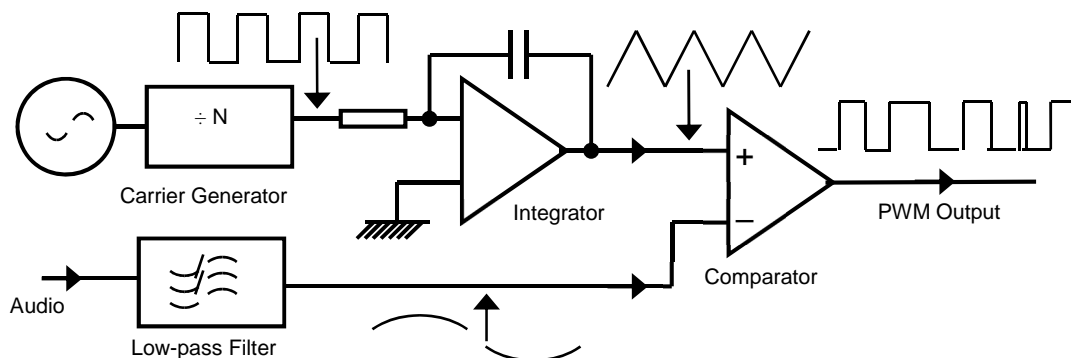

Figure A.1: A pulse-width modulator

The carrier frequency needs to be significantly higher than the highest audio frequency of interest, and the carrier a square-wave of 50:50 mark:space ratio. It is converted into a triangular wave by means of an integrator, and applied to one input of a comparator. The audio to be transmitted is applied to the other input of the comparator. The output of the comparator has a mark:space ratio proportional to the instantaneous amplitude of the audio. The low-pass filter is needed to avoid aliasing effects from any out-of-band components present on the audio input. The audio can be readily recovered from the pulse width modulated waveform using a simple low-pass filter.

The pulse-width modulator may be implemented using a single 'chip' programmed to generate a 1 MHz clock. Suitable devices are typically intended for controlling motors but can readily sink 15 mA, which is suitable for driving an LED transmitter.

A matching photo-receiver is required to provide an audio output for measurement. It typically comprises a photo-diode, head amplifier and data regenerator. The output of the regenerator is a 'box-car' logic-level waveform. Integrating this waveform with a low-pass filter recovers the original audio.

In practice, some refinements are needed to optimize the performance of the system. In particular, the linearity of the 'raw' modulator is imperfect. The solution is to demodulate the output of the comparator by means of an integrator, and to use the resulting audio as negative feedback. The demodulation process is a duplicate of what takes place in the receiver, and it follows that, if the loop gain is sufficiently large, the output of the receiver will be an exact duplicate of the original audio.

A prototype system is documented as BBC White Paper WHP 335 [i.6]. The measured THD+N of the prototype system was 0,09 % at a level of 0 dBu (2 V peak-peak), and the weighted noise was -64 dBq. The response was within ± 1 dB from 22 Hz to 22 kHz.

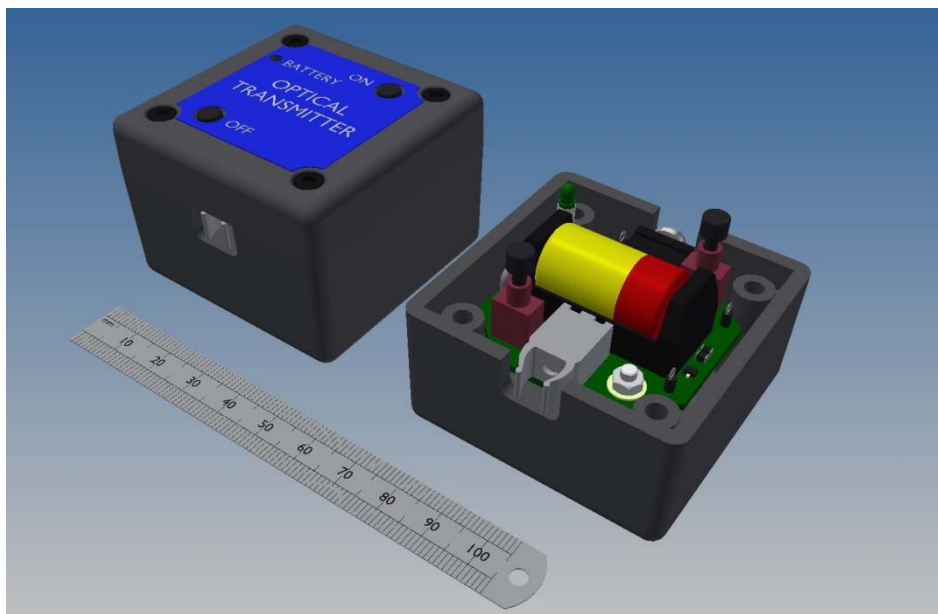

Figure A.2: An illustration of the prototype transmitter

Figure A.2 shows the construction of the transmitter in a small, commercially available conductive plastic box to provide shielding. Clearly visible are the red and yellow thionyl chloride cell to provide power and the LED transmitter (the grey device facing half-left). If the link were to be production engineered, it would be possible - and desirable - to make the modulator even smaller. Note that the fibre-optic link is mono-only, since there is no requirement to measure stereo performance.

Annex B (informative): Measurement set-up for electrical methods during radiated testing

Electrical connections within the field can influence the measurement result unless carefully positioned. The connection to the audio analyser and any external power supply cables should be oriented in a perpendicular direction to the electric field, and a CMAD or ferrite with an appropriate impedance over the frequency range of the testing should be applied, see figure B.1. This method of testing is not suitable for LF and MF frequencies due to large wavelengths.

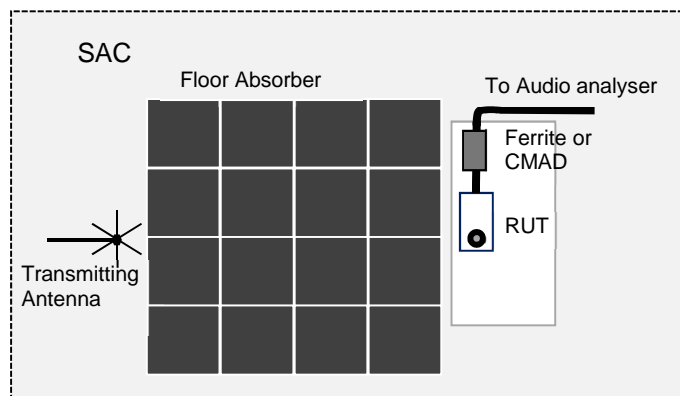

Figure B.1: Example set-up for electrical method (top view)

Annex C (informative): Change History

Version	Information about changes
1.1.1	First published version.

History

Document history			
V1.1.0	September 2018	EN Approval Procedure	AP 20181225: 2018-09-26 to 2018-12-25
V1.1.1	March 2019	Vote	V 20190525: 2019-03-26 to 2019-05-27