



**Broadband Direct Air-to-Ground Communications;
Equipment operating in the 1 900 MHz to 1 920 MHz
and 5 855 MHz to 5 875 MHz frequency bands;
Fixed pattern antennas;
Harmonised Standard covering the essential requirements of
article 3.2 of Directive 2014/53/EU**

Reference

DEN/BRAN-0060014

Keywords

3G, 3GPP, aeronautical, broadband, cellular,
E-UTRA, IMT, IMT-2000, IMT-Advanced, LTE,
mobile, network, radio, regulation, UMTS,
WCDMA

ETSI

650 Route des Lucioles
F-06921 Sophia Antipolis Cedex - FRANCE

Tel.: +33 4 92 94 42 00 Fax: +33 4 93 65 47 16

Siret N° 348 623 562 00017 - NAF 742 C
Association à but non lucratif enregistrée à la
Sous-Préfecture de Grasse (06) N° 7803/88

Important notice

The present document can be downloaded from:
<http://www.etsi.org/standards-search>

The present document may be made available in electronic versions and/or in print. The content of any electronic and/or print versions of the present document shall not be modified without the prior written authorization of ETSI. In case of any existing or perceived difference in contents between such versions and/or in print, the only prevailing document is the print of the Portable Document Format (PDF) version kept on a specific network drive within ETSI Secretariat.

Users of the present document should be aware that the document may be subject to revision or change of status. Information on the current status of this and other ETSI documents is available at
<https://portal.etsi.org/TB/ETSIDeliverableStatus.aspx>

If you find errors in the present document, please send your comment to one of the following services:
<https://portal.etsi.org/People/CommiteeSupportStaff.aspx>

Copyright Notification

No part may be reproduced or utilized in any form or by any means, electronic or mechanical, including photocopying and microfilm except as authorized by written permission of ETSI.

The content of the PDF version shall not be modified without the written authorization of ETSI.
The copyright and the foregoing restriction extend to reproduction in all media.

© European Telecommunications Standards Institute 2016.
All rights reserved.

DECT™, **PLUGTESTS™**, **UMTS™** and the ETSI logo are Trade Marks of ETSI registered for the benefit of its Members.
3GPP™ and **LTE™** are Trade Marks of ETSI registered for the benefit of its Members and of the 3GPP Organizational Partners.
GSM® and the GSM logo are Trade Marks registered and owned by the GSM Association.

Content

Intellectual Property Rights	6
Foreword.....	6
Modal verbs terminology.....	6
Executive summary	6
Introduction	7
1 Scope	8
2 References	8
2.1 Normative references	8
2.2 Informative references.....	8
3 Definitions, symbols and abbreviations	9
3.1 Definitions.....	9
3.2 Symbols.....	9
3.3 Abbreviations	9
4 Technical requirements specifications	10
4.1 Environmental profile.....	10
4.2 Conformance requirements	10
4.2.1 Introduction.....	10
4.2.2 Spectrum Emission Mask	11
4.2.2.1 Definition	11
4.2.2.2 Limits	11
4.2.2.3 Conformance.....	11
4.2.3 Transmitter Adjacent Channel Leakage Power (1 900 MHz to 1 920 MHz).....	11
4.2.3.1 Definition	11
4.2.3.2 Limits	11
4.2.3.3 Conformance.....	11
4.2.4 Transmitter spurious emissions and maximum unwanted emissions in the band 5,250 GHz to 5,850 GHz.....	11
4.2.4.1 Definition	11
4.2.4.2 Limits	12
4.2.4.3 Measurement bandwidths.....	12
4.2.4.4 Conformance.....	12
4.2.5 Maximum output power.....	12
4.2.5.1 Definition	12
4.2.5.2 Limits - Ground Station	12
4.2.5.3 Limits - Aircraft Station	12
4.2.5.4 Conformance.....	12
4.2.6 Altitude attenuation factor - Aircraft Station	12
4.2.6.1 Definition	12
4.2.6.2 Limits	13
4.2.6.3 Conformance.....	13
4.2.7 Compatibility with BFWA - Aircraft Station	13
4.2.7.1 Definition	13
4.2.7.2 Limits	13
4.2.7.3 Conformance.....	13
4.2.8 Receiver Minimum Sensitivity	13
4.2.8.1 Definition	13
4.2.8.2 Limit.....	13
4.2.8.3 Conformance.....	14
4.2.9 Receiver Spurious Response.....	14
4.2.9.1 Definition	14
4.2.9.2 Limit.....	14
4.2.9.3 Conformance.....	14
4.2.10 Receiver Adjacent Channel Selectivity.....	14
4.2.10.1 Definition	14

4.2.10.2	Limit.....	14
4.2.10.3	Conformance.....	14
4.2.11	Receiver Intermodulation Rejection	15
4.2.11.1	Definition	15
4.2.11.2	Limit.....	15
4.2.11.3	Conformance.....	15
4.2.12	Receiver Blocking	15
4.2.12.1	Definition	15
4.2.12.2	Limit.....	16
4.2.12.3	Conformance.....	16
4.2.13	Dedicated Antennas - Radiation Pattern Envelopes.....	16
4.2.13.1	Aircraft station	16
4.2.13.2	Ground station.....	17
4.2.13.2.1	Sectorial antenna	17
4.2.13.2.2	Directional antenna.....	18
4.2.13.2.3	Omnidirectional antenna.....	19
4.2.13.3	Conformance.....	20
4.2.14	Dedicated Antenna Gain Requirements.....	20
4.2.14.1	General.....	20
4.2.14.2	Antenna Maximum Gain.....	20
4.2.14.3	Conformance.....	20
5	Testing for compliance with technical requirements.....	20
5.1	Environmental conditions for testing	20
5.1.1	Ground and Aircraft Station Transceivers	20
5.1.2	Ground and Aircraft Station Antennas.....	21
5.2	Interpretation of the measurement results	21
5.3	Essential radio test suites.....	22
5.3.1	Introduction.....	22
5.3.2	Spectrum Emission Mask	22
5.3.2.1	Initial conditions	22
5.3.2.2	Procedure	22
5.3.2.3	Test requirement	22
5.3.3	Transmitter adjacent channel leakage power ratio (ACLR).....	22
5.3.3.1	Initial conditions	22
5.3.3.2	Procedure	23
5.3.3.3	Test requirement	23
5.3.4	Transmitter spurious emissions.....	23
5.3.4.1	Initial conditions	23
5.3.4.2	Procedure	23
5.3.4.3	Test requirement	23
5.3.5	Transmitter maximum output power.....	23
5.3.5.1	Initial conditions	23
5.3.5.2	Procedure	23
5.3.5.3	Test requirement	23
5.3.6	Altitude attenuation factor - Aircraft Station	24
5.3.6.1	Initial conditions	24
5.3.6.2	Procedure	24
5.3.6.3	Test requirement	24
5.3.7	Compatibility with BFWA - Aircraft Station	24
5.3.7.1	Initial conditions	24
5.3.7.2	Procedure	24
5.3.7.3	Test requirement	24
5.3.8	Receiver Minimum Sensitivity	24
5.3.8.1	Initial conditions	24
5.3.8.2	Procedure	24
5.3.8.3	Test requirement	25
5.3.9	Receiver Spurious Response.....	25
5.3.9.1	Initial conditions	25
5.3.9.2	Procedure	25
5.3.9.3	Test requirement	25
5.3.10	Receiver Adjacent Channel Selectivity.....	25

5.3.10.1	Initial conditions	25
5.3.10.2	Procedure	25
5.3.10.3	Test requirement	25
5.3.11	Receiver Intermodulation Rejection	26
5.3.11.1	Initial conditions	26
5.3.11.2	Procedure	26
5.3.11.3	Test requirement	26
5.3.12	Receiver Blocking	26
5.3.12.1	Initial conditions	26
5.3.12.2	Procedure	26
5.3.12.3	Test requirement	26
5.3.13	Dedicated antennas	26
Annex A (normative):	Relationship between the present document and the essential requirements of Directive 2014/53/EU	27
Annex B (normative):	Test specification.....	29
B.1	Normal test environment	29
B.2	RF Signals	29
B.2.1	Bandwidth	29
B.2.2	Channels	29
B.3	Test Configurations	29
B.3.1	Maximum output power, transmitter spurious emissions and operating band unwanted emissions	29
B.3.2	Altitude Attenuation factor	30
B.3.3	Receiver ACS, Blocking and Spurious.....	30
B.3.4	Receiver Intermodulation	31
Annex C (informative):	Environmental profile specification	32
Annex D (normative):	Geographical Data	33
D.1	Introduction	33
D.2	Altitude determination.....	33
D.3	BFWA mitigation.....	33
D.4	Time currency	33
Annex E (informative):	Bibliography.....	34
Annex F (informative):	Change History	35
History		36

Intellectual Property Rights

IPRs essential or potentially essential to the present document may have been declared to ETSI. The information pertaining to these essential IPRs, if any, is publicly available for **ETSI members and non-members**, and can be found in ETSI SR 000 314: "*Intellectual Property Rights (IPRs); Essential, or potentially Essential, IPRs notified to ETSI in respect of ETSI standards*", which is available from the ETSI Secretariat. Latest updates are available on the ETSI Web server (<https://ipr.etsi.org/>).

Pursuant to the ETSI IPR Policy, no investigation, including IPR searches, has been carried out by ETSI. No guarantee can be given as to the existence of other IPRs not referenced in ETSI SR 000 314 (or the updates on the ETSI Web server) which are, or may be, or may become, essential to the present document.

Foreword

This final draft Harmonised European Standard (EN) has been produced by ETSI Technical Committee Broadband Radio Access Networks (BRAN), and is now submitted for the Vote phase of the ETSI standards EN Approval Procedure.

The present document has been prepared under the Commission's standardisation request C(2015) 5376 final [i.7] to provide one voluntary means of conforming to the essential requirements of Directive 2014/53/EU on the harmonisation of the laws of the Member States relating to the making available on the market of radio equipment and repealing Directive 1999/5/EC [i.1].

Once the present document is cited in the Official Journal of the European Union under that Directive, compliance with the normative clauses of the present document given in table A.1 confers, within the limits of the scope of the present document, a presumption of conformity with the corresponding essential requirements of that Directive, and associated EFTA regulations.

Proposed national transposition dates	
Date of latest announcement of this EN (doa):	3 months after ETSI publication
Date of latest publication of new National Standard or endorsement of this EN (dop/e):	6 months after doa
Date of withdrawal of any conflicting National Standard (dow):	18 months after doa

Modal verbs terminology

In the present document "**shall**", "**shall not**", "**should**", "**should not**", "**may**", "**need not**", "**will**", "**will not**", "**can**" and "**cannot**" are to be interpreted as described in clause 3.2 of the [ETSI Drafting Rules](#) (Verbal forms for the expression of provisions).

"**must**" and "**must not**" are **NOT** allowed in ETSI deliverables except when used in direct citation.

Executive summary

The present document addresses the Broadband Direct Air-to-Ground Communications system based on the ETSI System Reference Document ETSI TR 103 108 [i.6]. This System Requirement document was used by the ECC, in conjunction with other contributions, to develop technology neutral ECC Decisions on the allocation of European spectrum in the frequency bands 1 900 MHz to 1 920 MHz and 5 855 MHz to 5 875 MHz.

The technical requirements in the present document reflect, in part, the results of studies undertaken within the CEPT on compatibility between broadband direct air-to-ground systems and other applications operating within, or adjacent to, the frequency bands that are designated for Broadband DA2GC operations.

Introduction

The technical requirements in the present document reflect, in part, the results of studies undertaken within the CEPT on compatibility between broadband direct air-to-ground systems and other applications operating within, or adjacent to, the frequency bands which are designated for BDA2GC operations. These studies are described in ECC Report 209 [i.2] (for the 1 900 MHz to 1 920 MHz band) and ECC Report 210 [i.3] (for the 5 855 MHz to 5 875 MHz band).

The resulting technical and operational requirements to be applied to BDA2GC systems in the 1 900 MHz to 1 920 MHz bands and the 5 855 MHz to 5 875 MHz bands are contained within ECC Decision(15)02 [i.4] and ECC Decision(15)03 [i.5] respectively.

1 Scope

The present document applies to the Ground Station, Aircraft Station and antenna equipment for DA2GC (TDD).

This radio equipment type is capable of operating in all or any part of the frequency bands given in table 1.

Table 1: DA2GC TDD service frequency bands

Direction of Transmission	Frequency Band
Transmit 1	1 900 MHz to 1 920 MHz
Receive 1	1 900 MHz to 1 920 MHz
Transmit 2	5 855 MHz to 5 875 MHz
Receive 2	5 855 MHz to 5 875 MHz

The present document contains requirements to demonstrate that radio equipment both effectively uses and supports the efficient use of radio spectrum in order to avoid harmful interference.

2 References

2.1 Normative references

References are either specific (identified by date of publication and/or edition number or version number) or non-specific. For specific references, only the cited version applies. For non-specific references, the latest version of the referenced document (including any amendments) applies.

Referenced documents which are not found to be publicly available in the expected location might be found at <http://docbox.etsi.org/Reference>.

NOTE: While any hyperlinks included in this clause were valid at the time of publication, ETSI cannot guarantee their long term validity.

The following referenced documents are necessary for the application of the present document.

- [1] ETSI EN 301 126-3-2 (V1.2.1) (12-2003): "Fixed Radio Systems; Conformance testing; Part 3-2: Point-to-Multipoint antennas - Definitions, general requirements and test procedures".
- [2] NIMA Technical Report TR8350.2 (1984, including amendment 1 of 03 January 2000 and amendment 2 of 23 June 2004): "Department of Defense World Geodetic System 1984. Its Definition and Relationships with Local Geodetic Systems".

NOTE: Available at <http://earth-info.nga.mil/GandG/publications/tr8350.2/wgs84fin.pdf>.

2.2 Informative references

References are either specific (identified by date of publication and/or edition number or version number) or non-specific. For specific references, only the cited version applies. For non-specific references, the latest version of the referenced document (including any amendments) applies.

NOTE: While any hyperlinks included in this clause were valid at the time of publication, ETSI cannot guarantee their long term validity.

The following referenced documents are not necessary for the application of the present document but they assist the user with regard to a particular subject area.

- [i.1] Directive 2014/53/EU of the European Parliament and of the Council of 16 April 2014 on the harmonisation of the laws of the Member States relating to the making available on the market of radio equipment and repealing Directive 1999/5/EC.
- [i.2] ECC Report 209: "Compatibility/sharing studies related to Broadband Direct-Air-to-Ground Communications (DA2GC) in the frequency bands 1900-1920 MHz / 2010-2025 MHz and services/applications in the adjacent bands".

- [i.3] ECC Report 210: "Compatibility/sharing studies related to Broadband Direct-Air-to-Ground Communications (DA2GC) in the frequency bands 5855-5875 MHz, 2400-2483.5 MHz and 3400-3600 MHz".
- [i.4] ECC Decision ECC/DEC(15)02: "The harmonised use of broadband Direct Air-to-Ground Communications (DA2GC) systems in the frequency band 1900-1920 MHz".
- [i.5] ECC Decision ECC/ DEC(15)03: "The harmonised use of broadband Direct Air-to-Ground Communications (DA2GC) systems in the frequency band 5855-5875 MHz".
- [i.6] ETSI TR 103 108 (V1.1.1) (07-2013): "Electromagnetic compatibility and Radio spectrum Matters (ERM); System Reference document (SRdoc); Broadband Direct-Air-to-Ground Communications System operating in the 5,855 GHz to 5,875 GHz band using 3G technology".
- [i.7] Commission Implementing Decision C(2015) 5376 final of 4.8.2015 on a standardisation request to the European Committee for Electrotechnical Standardisation and to the European Telecommunications Standards Institute as regards radio equipment in support of Directive 2014/53/EU of the European Parliament and of the Council.

3 Definitions, symbols and abbreviations

3.1 Definitions

For the purposes of the present document, the terms and definitions given in Directive 2014/53/EU [i.1] and the following apply:

altitude: height above ground level

dedicated antenna: removable antenna supplied and assessed with the radio equipment, designed as an indispensable part of the equipment

3.2 Symbols

For the purposes of the present document, the following symbols apply:

f_o frequency offset

3.3 Abbreviations

For the purposes of the present document, the following abbreviations apply:

ACLR	Adjacent Channel Leakage Ratio
ACS	Adjacent Channel Selectivity
AS	Aircraft Station
BER	Bit Error Rate
BFWA	Broadband Fixed Wireless Access
BW	BandWidth
CEPT	Conférence Européenne des Postes et des Télécommunications
CW	Carrier Wave
DA2GC	Direct Air to Ground Communications
e.i.r.p.	Effective Isotropic Radiated Power
ECC	Electronic Communications Committee
EEC	European Economic Community
EMC	ElectroMagnetic Compatibility
GNSS	Global Navigation Satellite System
GS	Ground Station
LTE	Long Term Evolution
LV	Low Voltage
Mcps	Megachips per second
OFDMA	Orthogonal Frequency Division Multiple Access
QPSK	Quadrature Phase-Shift Keying
REFSENS	receiver REFERENCE SENSitivity

REQPERF	receiver REQuired PERFormance
RF	Radio Frequency
RMS	Root Mean Square
TDD	Time Division Duplex
WCDMA	Wideband Code Division Multiple Access

4 Technical requirements specifications

4.1 Environmental profile

The technical requirements of the present document apply under the environmental profile for operation of the equipment, which shall be declared by the manufacturer. The equipment shall comply with all the technical requirements of the present document at all times when operating within the boundary limits of the declared operational environmental profile.

4.2 Conformance requirements

4.2.1 Introduction

This clause describes the conformance requirements for the DA2GC equipment. The requirements for the bands 1 900 MHz to 1 920 MHz and 5 855 MHz to 5 875 MHz are identical unless otherwise stated. Consequently, the maximum channel bandwidth is 20 MHz for each band.

To meet the essential requirement of Directive 2014/53/EU [i.1] for DA2GC equipment five essential parameters have been identified. Table 2 provides a cross reference between these five essential parameters and the corresponding ten technical requirements for equipment within the scope of the present document.

To fulfill an essential parameter the compliance with all the corresponding technical requirements in table 2 shall be verified.

The required performance REQPERF is defined as follows:

- For WCDMA modulation: "BER \leq 0,1 %".
- For OFDMA modulation: "95 % of theoretical maximum throughput when using the QPSK modulation scheme".

The reference sensitivity REFSENS is the minimum signal power required to achieve REQPERF.

Table 2: Cross references

Essential parameter	Corresponding technical requirements
Spectrum emissions mask	4.2.2 Spectrum emission mask
	4.2.3 Transmitter Adjacent Channel Leakage power Ratio (ACLR)
Conducted spurious emissions from the transmitter antenna connector	4.2.4 Transmitter spurious emissions
Accuracy of maximum output power	4.2.5 Maximum output power
Receiver Parameters	4.2.8 Minimum Receiver Sensitivity
	4.2.9 Receiver Spurious Response
	4.2.10 Receiver Adjacent Band Rejection
	4.2.11 Receiver Intermodulation Rejection
	4.2.12 Receiver Blocking Immunity
Antennas	4.2.13 Dedicated Antennas

4.2.2 Spectrum Emission Mask

4.2.2.1 Definition

Spectrum emission mask defines an out-of-band emission requirement for the Ground Station and Aircraft Station transmitters. These out-of-band emissions are emissions immediately outside the channel bandwidth resulting from the modulation process and non-linearity in the transmitter but excluding spurious emissions. Its measurement is at the antenna port.

4.2.2.2 Limits

The limits given in table 3 shall apply.

Table 3: Spectrum Emission Mask Limits

Sub-System	Out-of-band Frequency Offset f_{offset} (MHz)	Maximum Emission Power (dBm/MHz)
Ground Station	$0,475 \leq f_{\text{offset}} < 0,75 \times \text{BW}$	-12
	$0,75 \times \text{BW} \leq f_{\text{offset}} < 2,5 \times \text{BW}$	-32
Aircraft Station	$0,475 \leq f_{\text{offset}} < 0,75 \times \text{BW}$	-14
	$0,75 \times \text{BW} \leq f_{\text{offset}} < 2,5 \times \text{BW}$	-34

4.2.2.3 Conformance

Conformance tests described in clause 5.3.2 shall be carried out.

4.2.3 Transmitter Adjacent Channel Leakage Power (1 900 MHz to 1 920 MHz)

4.2.3.1 Definition

Transmitter Adjacent Channel Leakage power Ratio (ACLR) is the ratio of the mean power centred on the assigned channel frequency to the mean power centred on an adjacent channel frequency. The requirements shall apply solely for the band 1 900 MHz to 1 920 MHz and for all operating modes foreseen by the manufacturer's specification.

4.2.3.2 Limits

The ACLR shall be equal to or greater than the limits given in table 4.

Table 4: Transmitter ACLR limits

	Channel Bandwidth					
	1,4 MHz	3 MHz	5 MHz	10 MHz	15 MHz	20 MHz
Aircraft Station first ACLR	32,2 dB	32,2 dB	32,2 dB	32,2 dB	32,2 dB	32,2 dB
Aircraft Station second ACLR	42,2 dB	42,2 dB	42,2 dB	42,2 dB	42,2 dB	42,2 dB
Ground Station first ACLR	44,2 dB	44,2 dB	44,2 dB	44,2 dB	44,2 dB	44,2 dB
Ground Station second ACLR	52,2 dB	52,2 dB	52,2 dB	52,2 dB	52,2 dB	52,2 dB

4.2.3.3 Conformance

Conformance tests described in clause 5.3.3 shall be carried out.

4.2.4 Transmitter spurious emissions and maximum unwanted emissions in the band 5,250 GHz to 5,850 GHz

4.2.4.1 Definition

Transmitter spurious emissions are emissions that are caused by unwanted transmitter effects such as harmonics emission, parasitic emission, intermodulation products and frequency conversion products, but exclude out-of-band emissions. Unwanted emissions consist of spurious emissions and out-of-band emissions. This is measured at the RF output port.

4.2.4.2 Limits

The power of any spurious emission in either band shall not exceed the maximum level given by:

The spurious emissions from the antenna connector during transmit mode are defined as unwanted power in the bands from 30 MHz up to $f_c - 2,5 \times BW$ and from $f_c + 2,5 \times BW$ up to $5 \times f_c$, where f_c is the carrier frequency and BW is the signal bandwidth.

The maximum level of spurious emission is: $-36 \text{ dBm}/(100 \text{ kHz})$, for $9 \text{ kHz} \leq f \leq 1 \text{ GHz}$
 $-30 \text{ dBm}/\text{MHz}$, for $1 \text{ GHz} < f \leq 26 \text{ GHz}$

For the band 5 855 MHz to 5 875 MHz the following additional requirement shall apply:

The maximum level of unwanted emission is: $-50 \text{ dBm}/\text{MHz}$ for $5,250 \text{ GHz} < f \leq 5,850 \text{ GHz}$.

4.2.4.3 Measurement bandwidths

The measurement bandwidths as defined in table 5 shall be used.

Table 5: Transmitter Spurious Emissions Measurement Bandwidths

Frequency range	Measurement Bandwidth
$9 \text{ kHz} \leq 150 \text{ kHz}$	1 kHz
$150 \text{ kHz} \leq 30 \text{ MHz}$	10 kHz
$30 \text{ MHz} \leq 1\text{GHz}$	100 kHz
$1 \text{ GHz} \leq 12,75 \text{ GHz}$	1 MHz

4.2.4.4 Conformance

Conformance tests described in clause 5.3.4 shall be carried out.

4.2.5 Maximum output power

4.2.5.1 Definition

The maximum output power is the power measured at the antenna port of the transmitter. The equipment shall use dedicated antennas to respect e.i.r.p. limits.

4.2.5.2 Limits - Ground Station

The measured output power shall not exceed 28 dBm/MHz or 38 dBm. The maximum e.i.r.p. shall not exceed 50 dBm/MHz.

4.2.5.3 Limits - Aircraft Station

The measured output power shall not exceed 26 dBm/MHz or 36 dBm. The maximum e.i.r.p. shall not exceed 34 dBm/MHz in the band 1 900 MHz to 1 920 MHz and shall not exceed 29 dBm/MHz in the band 5 855 MHz to 5 875 MHz.

There shall be no transmission for altitudes less than 3 000 metres.

4.2.5.4 Conformance

Conformance tests described in clause 5.3.5 shall be carried out.

4.2.6 Altitude attenuation factor - Aircraft Station

4.2.6.1 Definition

The "Altitude Attenuation Factor" reduces the maximum output power of the aircraft station, as defined in clause 4.2.5, to protect other co-channel, such as Intelligent Transport Systems, or adjacent band services such as radar.

The aircraft station altitude shall be determined as detailed in annex D.

4.2.6.2 Limits

The limits are specified in table 6.

Table 6: Aircraft Station Altitude Attenuation Factor

Altitude (metres)	Attenuation (dB)	Resultant Maximum Output Power at Antenna Port (dBm/MHz)
3 000 to 4 999	8	18
5 000 to 5 999	6	20
6 000 to 6 999	4	22
≥ 7 000	0	26

4.2.6.3 Conformance

Conformance tests described in clause 5.3.6 shall be carried out.

4.2.7 Compatibility with BFWA - Aircraft Station

4.2.7.1 Definition

Aircraft Station Compatibility with BFWA systems introduces a reduction in maximum transmitter output power of the aircraft station when required to ensure compatibility with BFWA systems. It only applies to the band 5 855 MHz to 5 875 MHz.

The requirement for BFWA mitigation for a given aircraft station position shall be determined as detailed in Annex D.

4.2.7.2 Limits

The aircraft station shall determine if BFWA mitigation is to be applied by using data stored locally in the aircraft station equipment. This data shall be automatically refreshed by the aircraft station at least every seven days. The data shall provide updated geographic information on regions where BFWA is authorized.

When active, or when the data itself has not been refreshed within seven days, the maximum transmitter output power shall be limited to 22 dBm/MHz.

4.2.7.3 Conformance

Conformance tests described in clause 5.3.7 shall be carried out.

4.2.8 Receiver Minimum Sensitivity

4.2.8.1 Definition

Minimum sensitivity, used as REFSSENS in the present document, is defined as the minimum power of the wanted signal to achieve REQPERF in the absence of interference.

4.2.8.2 Limit

The receiver minimum sensitivity for each channel bandwidth (as appropriate) shall be that specified in table 7 or better.

Table 7: Receiver Minimum Sensitivity Limits

Channel Bandwidth	Receiver Minimum Sensitivity
20 MHz	-104,5 dBm
15 MHz	-105,7 dBm
10 MHz	-107,5 dBm
5 MHz	-110,5 dBm
3 MHz	-112,7 dBm
1,4 MHz	-116 dBm

4.2.8.3 Conformance

Conformance tests described in clause 5.3.8 shall be carried out.

4.2.9 Receiver Spurious Response

4.2.9.1 Definition

The spurious response rejection is a measure of the capability of the receiver to receive a wanted signal without exceeding a given degradation due to the presence of an unwanted CW signal in the receiver passband.

4.2.9.2 Limit

The REQPERF shall be achieved with the wanted signal and the unwanted CW signal set to values specified in table 8.

Table 8: Receiver Spurious Response Limits

	Channel Bandwidth					
	1,4 MHz	3 MHz	5 MHz	10 MHz	15 MHz	20 MHz
Wanted Reference Signal (OFDMA)	REFSENS + 6 dB	REFSENS + 6 dB	REFSENS + 6 dB	REFSENS + 6 dB	REFSENS + 6 dB	REFSENS + 6 dB
Wanted Reference Signal (WCDMA)	N/A	N/A	REFSENS + 10 dB	REFSENS + 10 dB	N/A	N/A
CW Interferer Power	-44 dBm	-44 dBm	-44 dBm	-44 dBm	-44 dBm	-44 dBm
CW Interferer Frequency	CW interferer test frequencies are defined as: <ul style="list-style-type: none"> • 1 900 MHz to 1 920 MHz in 1 MHz increments • 5 855 MHz to 5 875 MHz in 1 MHz increments 					

4.2.9.3 Conformance

Conformance tests described in clause 5.3.9 shall be carried out.

4.2.10 Receiver Adjacent Channel Selectivity

4.2.10.1 Definition

Adjacent Channel Selectivity (ACS) is a measure of a receiver's ability to achieve minimum throughput requirements in the presence of an adjacent channel signal at a specific frequency offset from the given channel. ACS can strictly be defined as the ratio (in dB) of the receiver filter's attenuation on the assigned channel frequency to the receive filter attenuation on the adjacent channels.

4.2.10.2 Limit

The receiver adjacent channel selectivity shall be as defined in table 9.

Table 9: Receiver Adjacent Channel Selectivity Limits

	Channel Bandwidth					
	1,4 MHz	3 MHz	5 MHz	10 MHz	15 MHz	20 MHz
ACS (dB)	36	36	36	33	30	27

4.2.10.3 Conformance

Conformance tests described in clause 5.3.10 shall be carried out.

4.2.11 Receiver Intermodulation Rejection

4.2.11.1 Definition

Third and higher order mixing of the two interfering RF signals can produce an interfering signal in the band of the desired channel. Intermodulation response rejection is a measure of the capability of the receiver to receive a wanted signal on its assigned channel frequency in the presence of two interfering signals which have a specific frequency relationship to the wanted signal.

4.2.11.2 Limit

The REQPERF shall be achieved for the scenarios detailed in table 10.

Table 10: Receiver Intermodulation Rejection Limits

	Channel Bandwidth					
	1,4 MHz	3 MHz	5 MHz	10 MHz	15 MHz	20 MHz
Wanted Reference Signal (OFDMA)	REFSENS + 12 dB	REFSENS + 8 dB	REFSENS + 6 dB	REFSENS + 6 dB	REFSENS + 7 dB	REFSENS + 9 dB
Wanted Reference Signal (WCDMA)	N/A	N/A	REFSENS + 3 dB	REFSENS + 3 dB	N/A	N/A
CW Interferer Power	-46 dBm					
CW Interferer Frequency Offset	± 2,8 MHz	± 6 MHz	± 10 MHz	± 12,5 MHz	± 15 MHz	± 17,5 MHz
Modulated Interferer Bandwidth	1,4 MHz	3 MHz	5 MHz	5 MHz	5 MHz	5 MHz
Modulated Interferer Power	-46 dBm					
Modulated Interferer Frequency Offset	± 5,6 MHz	± 12 MHz	± 20 MHz	± 25 MHz	± 30 MHz	± 35 MHz

The wanted reference signal is the output from the ground or aircraft station emulator. Its modulation type is either OFDMA or WCDMA.

4.2.11.3 Conformance

Conformance tests described in clause 5.3.11 shall be carried out.

4.2.12 Receiver Blocking

4.2.12.1 Definition

Receiver blocking is a measure of the capability of the receiver to receive a wanted modulated signal at the nominal frequency without exceeding a given degradation due to the presence of an unwanted CW high input signal, which is not a direct spurious frequency of the receiver under test. It is specified as the ratio in dB of the level of the unwanted signal to a specified level of the wanted signal at the receiver input for which the REQPERF is achieved.

4.2.12.2 Limit

The REQPERF shall be achieved for each of the unwanted interference scenarios detailed in table 11.

Table 11: Receiver Blocking Limits

	Channel Bandwidth					
	1,4 MHz	3 MHz	5 MHz	10 MHz	15 MHz	20 MHz
Wanted Reference Signal (OFDMA)	REFSENS + 6 dB	REFSENS + 6 dB	REFSENS + 6 dB	REFSENS + 6 dB	REFSENS + 7 dB	REFSENS + 8 dB
Wanted Reference Signal (WCDMA)	N/A	N/A	REFSENS + 3 dB	REFSENS + 3 dB	N/A	N/A
Interferer Signal power with Frequency Offset, (f_o) within the range: <ul style="list-style-type: none"> 15 MHz < f_o ≤ 60 MHz 	-44 dBm					
Interferer Signal power with Frequency Offset, (f_o) within the range: <ul style="list-style-type: none"> 60 MHz < f_o ≤ 85 MHz 	-30 dBm					
Interferer Signal power with Frequency Offset, (f_o) within the range: <ul style="list-style-type: none"> 85 MHz < f_o with a maximum frequency of 12 750 MHz 	-15 dBm					

The wanted reference signal is the output from the ground or aircraft station emulator. Its modulation type is either OFDMA or WCDMA.

4.2.12.3 Conformance

Conformance tests described in clause 5.3.12 shall be carried out.

4.2.13 Dedicated Antennas - Radiation Pattern Envelopes

4.2.13.1 Aircraft station

The aircraft station antenna radiation pattern envelope is defined below in figure 1 and table 12. The limits apply to all angles of azimuth.

The antenna is connected to the aircraft station transceiver via a feeder cable with a maximum assumed attenuation of 4 dB.

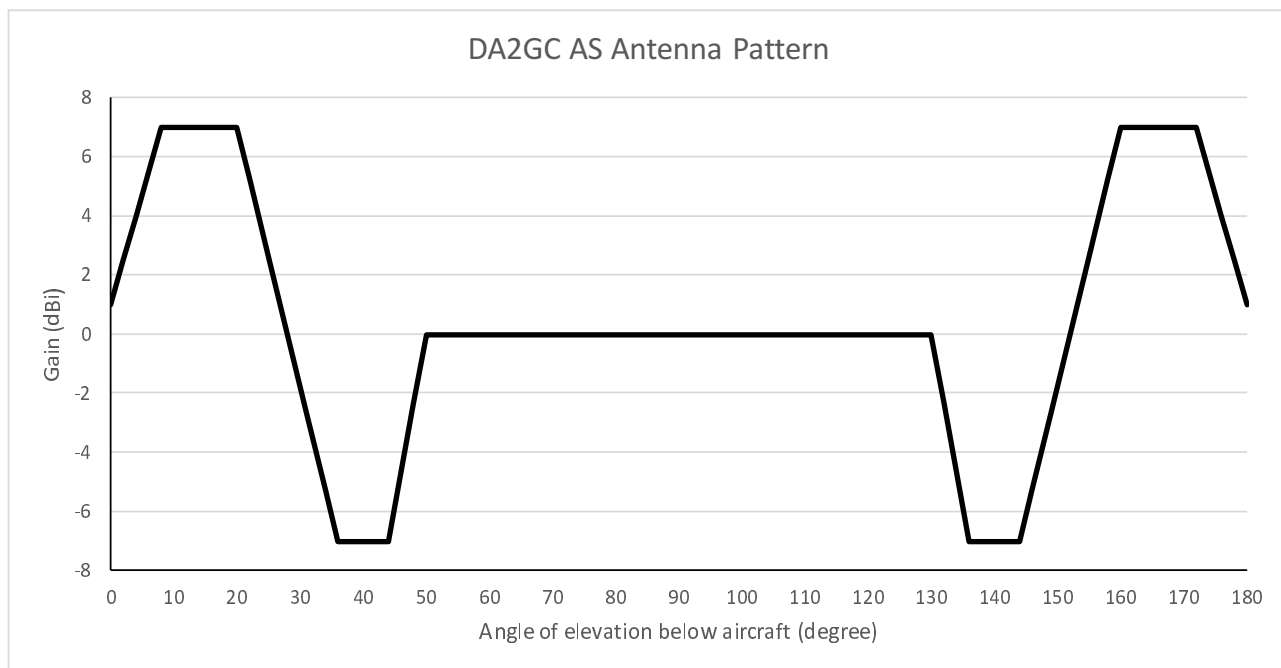

Figure 1: Antenna Radiation Pattern Envelope - Aircraft Station

Table 12: Antenna Radiation Pattern - Aircraft Station

Angle (degree)	Co-polar Gain (dBi)
0	1
8	7
20	7
36	-7
44	-7
50	0
130	0
136	-7
144	-7
160	7
172	7
180	1

4.2.13.2 Ground station

4.2.13.2.1 Sectorial antenna

The sectorial antenna radiation pattern envelope is defined below in figure 2 and table 13. The limits apply to all angles of azimuth.

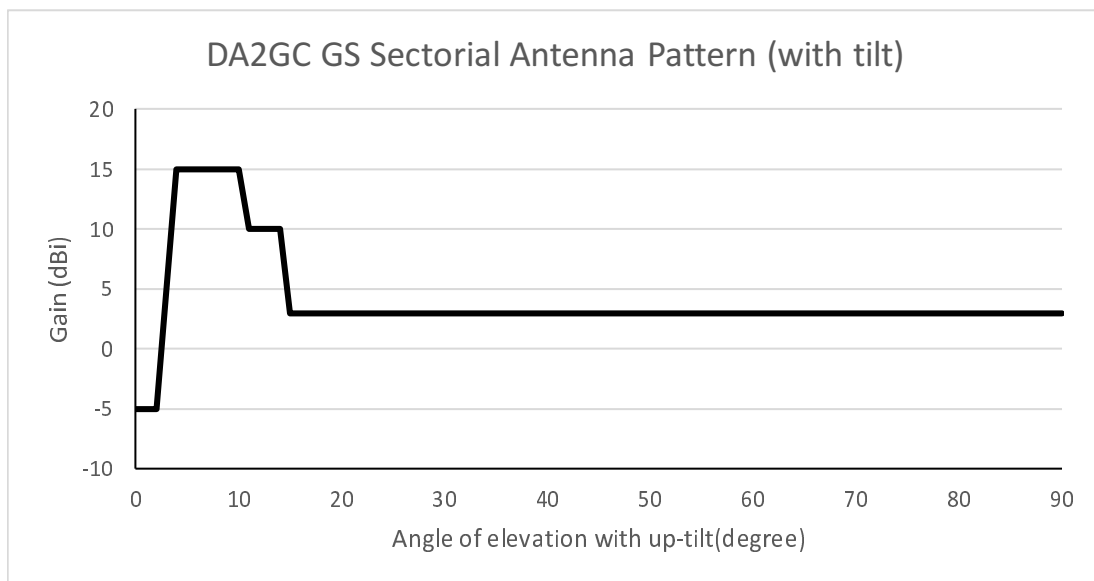

Figure 2: Antenna Radiation Pattern Envelope - Sector - Ground Station

Table 13: Antenna Radiation Pattern - Sector - Ground Station

Angle (degree)	Co-polar Gain (dBi)
0	-5
3	-5
4	15
10	15
11	10
14	10
15	3
90	3

4.2.13.2.2 Directional antenna

The directional antenna radiation pattern envelope is defined below in figure 3 and table 14. The limits are applicable for both azimuth and elevation angles.

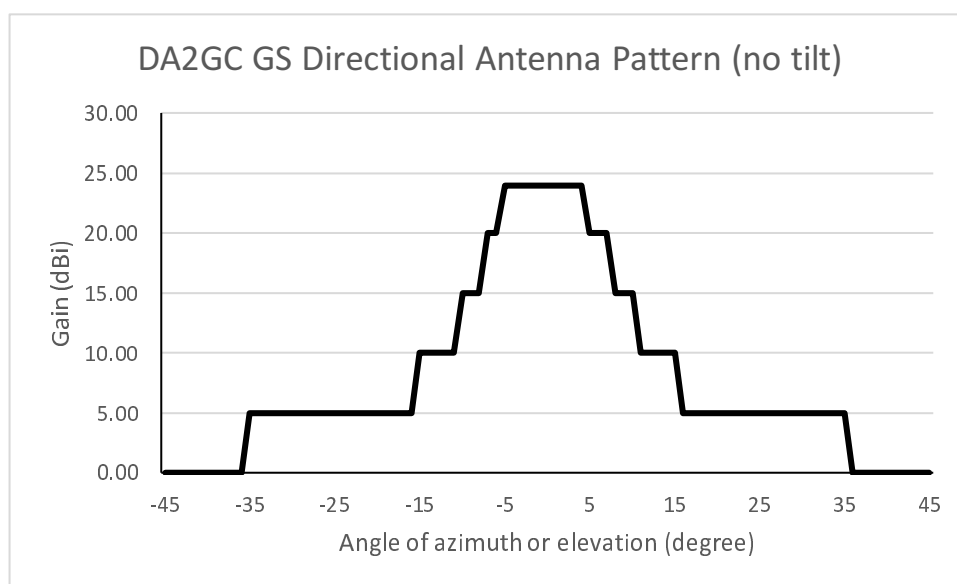

Figure 3: Antenna Radiation Pattern Envelope - Directional - Ground Station

Table 14: Antenna Radiation Pattern - Directional - Ground Station

Angle (degree)	Co-polar Gain (dBi)
-45	0
-36	0
-35	5
-16	5
-15	10
-11	10
-10	15
-8	15
-7	20
-6	20
-5	24
5	24
6	20
7	20
8	15
10	15
11	10
15	10
16	5
35	5
36	0
45	0

4.2.13.2.3 Omnidirectional antenna

The omnidirectional antenna radiation pattern envelope is defined below in figure 4 and table 15. The limits apply to all angles of azimuth.

**Figure 4: Antenna Radiation Pattern Envelope - Omni - Ground Station**

Table 15: Antenna Radiation Pattern - Omni - Ground Station

Angle (degree)	Co-polar Gain (dBi)
0	7
29	7
30	0
69	0
70	-5
110	-5
111	0
150	0
151	7
180	7

4.2.13.3 Conformance

Conformance requirements are described in clause 5.3.13.

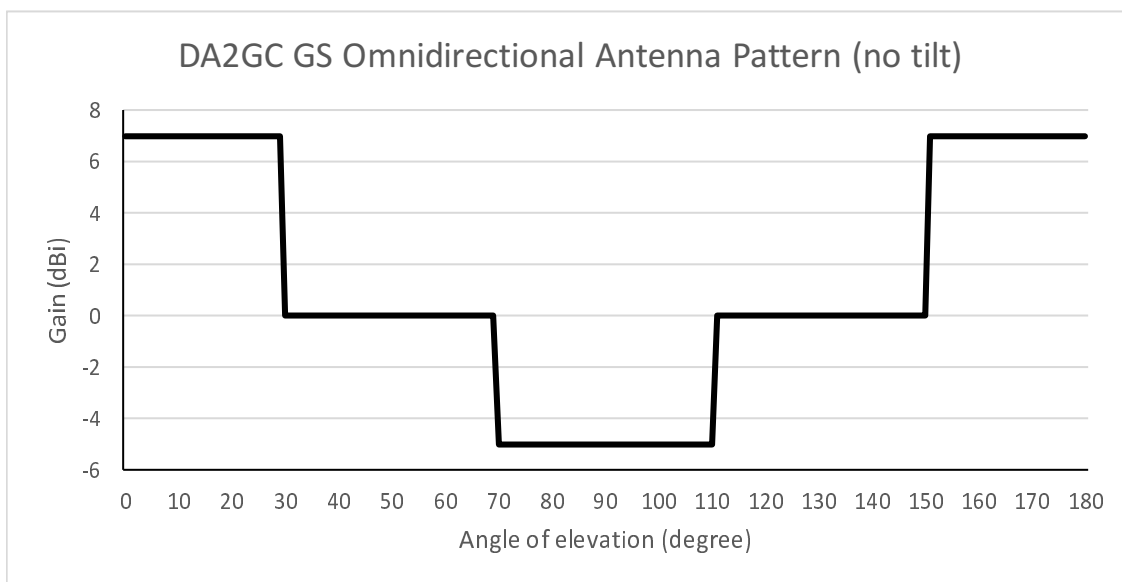
4.2.14 Dedicated Antenna Gain Requirements

4.2.14.1 General

An antenna that employs a radome, shall meet the requirements of the present document with the radome in place.

The gain of the antenna is specified as the maximum gain of the antenna with reference to an isotropic radiator and is expressed in dBi.

The gain parameters apply for linearly polarized antennas.

The parameters for linear polarized antennas apply equally to both horizontal and vertical linearly polarized antennas.

4.2.14.2 Antenna Maximum Gain

The maximum gain for each specified antenna is as shown in table 16.

Table 16: Antenna Maximum Gain

Antenna Type	Gain (dBi)
Aircraft station antenna	7
Sectorial antenna	15
Directional antenna	24
Omnidirectional antenna	7

4.2.14.3 Conformance

Conformance tests are described in clause 5.3.13.

5 Testing for compliance with technical requirements

5.1 Environmental conditions for testing

5.1.1 Ground and Aircraft Station Transceivers

Tests defined in the present document shall be carried out at representative points within the boundary limits of the required operational environmental profile.

Where technical performance varies subject to environmental conditions, tests shall be carried out under a sufficient variety of environmental conditions (within the boundary limits of the required operational environmental profile) to give confidence of compliance for the affected technical requirements.

5.1.2 Ground and Aircraft Station Antennas

Tests defined in the present document shall be carried out at representative points within the boundary limits of the declared operational environmental profile.

Where technical performance varies subject to environmental conditions, tests shall be carried out under a sufficient variety of environmental conditions (within the boundary limits of the declared operational environmental profile) to give confidence of compliance for the affected technical requirements.

5.2 Interpretation of the measurement results

The interpretation of the results recorded in a test report for the measurements described in the present document shall be as follows:

- the measured value related to the corresponding limit shall be used to decide whether an equipment meets the requirements of the present document;
- the value of the measurement uncertainty for the measurement of each parameter shall be documented in the test report;
- the recorded value of the measurement uncertainty shall be, for each measurement, equal to or lower than the values in table 17.

For the test methods, according to the present document, the measurement uncertainty figures as detailed in table 17 shall apply.

Table 17: Maximum measurement uncertainty of the test system

Parameter	Conditions	Uncertainty
5.3.2 Spectrum emission mask	-	± 1,5 dB
5.3.3 Transmitter adjacent channel leakage power ratio (ACLR)	General requirement	± 0,8 dB
5.3.4 Transmitter spurious emissions	For GS and coexistence bands	± 2,0 dB
	Outside above (band 1 900 MHz to 1 920 MHz): <ul style="list-style-type: none"> • $f \leq 2,2$ GHz • $2,2$ GHz $< f \leq 4$ GHz • 4 GHz $< f$ 	± 1,5 dB ± 2,0 dB ± 4,0 dB
	Outside above (band 5 855 MHz to 5 875 MHz) <ul style="list-style-type: none"> • $5,2$ GHz $< f \leq 5,85$ GHz • $5 875$ GHz $< f$ 	± 1,5 dB ± 2,0 dB
5.3.5 Maximum output power		± 0,7 dB
5.3.6 Altitude attenuation factor		± 0,7 dB
5.3.7 Compatibility with BFWA		± 0,7 dB
5.3.8 Minimum Receiver Sensitivity		± 1,5 dB
5.3.9 Receiver Spurious Response	For GS and coexistence bands	± 2,0 dB
	Outside above (band 1 900 MHz to 1 920 MHz): <ul style="list-style-type: none"> • $f \leq 2,2$ GHz • $2,2$ GHz $< f \leq 4$ GHz • 4 GHz $< f$ 	± 1,5 dB ± 2,0 dB ± 4,0 dB
	Outside above (band 5 855 MHz to 5 875 MHz) <ul style="list-style-type: none"> • $5,2$ GHz $< f \leq 5,85$ GHz • $5 875$ GHz $< f$ 	± 1,5 dB ± 2,0 dB
5.3.10 Receiver Adjacent Channel Selectivity		± 0,8 dB
5.3.11 Receiver Intermodulation Rejection		± 0,8 dB

Parameter	Conditions	Uncertainty
5.3.12 Receiver Blocking		$\pm 0,8$ dB
5.3.13 Dedicated Antennas		$\pm 1,5$ dB
e.i.r.p measurements		± 6 dB
Aircraft altitude		± 50 m
<p>NOTE 1: For RF tests it should be noted that the uncertainties in this table apply to the Test System operating into a nominal 50 Ω load and do not include system effects due to mismatch between the equipment under test and the Test System.</p> <p>NOTE 2: If the Test System for a test is known to have a measurement uncertainty greater than that specified in this table, this equipment can still be used provided that an adjustment is made as follows: any additional uncertainty in the Test System over and above that specified in this table is used to tighten the Test Requirements - making the test harder to pass (for some tests, e.g. receiver tests, this may require modification of stimulus signals). This procedure ensures that a Test System not compliant with this table does not increase the probability of passing an equipment under test that would otherwise have failed a test if a Test System compliant with this table had been used.</p>		

5.3 Essential radio test suites

5.3.1 Introduction

This clause describes the test suites for DA2GC equipment.

The measurement system required for each test is presented for information in clause B.3.

5.3.2 Spectrum Emission Mask

5.3.2.1 Initial conditions

For the spectrum emission mask requirement the test suite is specified in clause B.3.1. The test requirements of the present document defined in clause 4.2.2 shall apply.

Test environment: see clause B.1 and clause B.2.

- 1) Connect the signal analyser to the equipment antenna connector.

As a general rule, the resolution bandwidth of the measuring equipment should be equal to the measurement bandwidth. However, to improve measurement accuracy, sensitivity, efficiency and to avoid e.g. carrier leakage, the resolution bandwidth may be less than the measurement bandwidth. When the resolution bandwidth is less than the measurement bandwidth, the result should be integrated over the measurement bandwidth in order to obtain the equivalent noise bandwidth of the measurement bandwidth.

- 2) Detection mode: True RMS.

5.3.2.2 Procedure

- 1) Set the equipment to transmit at maximum power.
- 2) Step the centre frequency of the measurement filter in contiguous steps and measure the emission within the specified frequency ranges with a 1 MHz measurement bandwidth.

5.3.2.3 Test requirement

The results obtained shall be compared to the limits in clause 4.2.2.2 in order to prove compliance.

5.3.3 Transmitter adjacent channel leakage power ratio (ACLR)

5.3.3.1 Initial conditions

For the adjacent channel leakage power ratio requirement the test suite is specified in clause B.3.1.

- 1) Test environment: see clause B.1 and clause B.2.

- 2) Set up the test system according to clause B.3.1.
- 3) Connect the equipment antenna connector to the measurement equipment using an attenuator or a directional coupler if necessary. Any insertion losses shall be calibrated and taken into account.
- 4) The measurement equipment characteristics shall be:
 - measurement filter bandwidth: 3,84 MHz;
 - detection mode: true RMS voltage or true average power.

5.3.3.2 Procedure

- 1) Set the equipment to transmit at maximum power.
- 2) Measure ACLR inside sub-block gap for a 3,84 Mcps adjacent channel carrier.

5.3.3.3 Test requirement

The results obtained shall be compared to the limits in clause 4.2.3.2 in order to prove compliance.

5.3.4 Transmitter spurious emissions

5.3.4.1 Initial conditions

- 1) Test environment: see clause B.1 and clause B.2.
- 2) Set up the test system according to clause B.3.1.
- 3) Connect the equipment antenna connector to the measurement equipment using an attenuator or a directional coupler if necessary. Any insertion losses shall be calibrated and taken into account.
- 4) Measurements shall use a measurement bandwidth as specified in clause 4.2.4.3.
- 5) Detection mode: True RMS.

5.3.4.2 Procedure

- 1) Set the equipment to transmit at maximum power.
- 2) Measure the emission at the specified frequencies with specified measurement bandwidth and note that the measured value does not exceed the specified value.

5.3.4.3 Test requirement

The results obtained shall be compared to the limits in clause 4.2.4.2 in order to prove compliance.

5.3.5 Transmitter maximum output power

5.3.5.1 Initial conditions

- 1) Test environment: see clause B.1 and clause B.2.
- 2) Connect the power measuring equipment to the ground station antenna connector as shown in clause B.3.1.

5.3.5.2 Procedure

- 1) Set the equipment to transmit at maximum power.
- 2) Measure the mean power for each carrier at the equipment antenna connector.

5.3.5.3 Test requirement

The results obtained shall be compared to the limits in clause 4.2.5.2 in order to prove compliance.

5.3.6 Altitude attenuation factor - Aircraft Station

5.3.6.1 Initial conditions

- 1) Test environment: see clause B.1 and clause B.2.
- 2) Connect the aircraft station to a ground station emulator via fixed and variable attenuators and coupler as shown in clause B.3.2.

5.3.6.2 Procedure

- 1) Increase the variable attenuation until the aircraft station transmitter output reaches its maximum value. The measured value shall compensate for any losses introduced by the coupler and cabling between the coupler and the spectrum analyser.
- 2) Set the aircraft station altitude to the initial value of 7 000 metres using test software embedded in the aircraft station.

5.3.6.3 Test requirement

- 1) Progressively set the altitude to 6 999, 6 000, 5 999, 5 000, 4 999 and 3 000 metres.
- 2) For each altitude measure the transmitter output power.
- 3) The result obtained shall be compared to the limits in clause 4.2.6.2 in order to prove compliance.

5.3.7 Compatibility with BFWA - Aircraft Station

5.3.7.1 Initial conditions

- 1) Test environment: see clauses B.1 and B.2.
- 2) Initial conditions defined in clause 5.3.6.1 are applicable.

5.3.7.2 Procedure

- 1) Increase the variable attenuation until the aircraft station transmitter output reaches its maximum value. The measured value shall compensate for any losses introduced by the coupler and cabling between the coupler and the spectrum analyser.
- 2) Set the aircraft station altitude to 7 000 metres using test software embedded in the aircraft station.
- 3) Select the BFWA compatibility function using test software embedded in the aircraft station.

5.3.7.3 Test requirement

- 1) Measure the transmitter output power.
- 2) The result obtained shall be compared to the limit in clause 4.2.7.2 in order to prove compliance.

5.3.8 Receiver Minimum Sensitivity

5.3.8.1 Initial conditions

- 1) Test environment: see clauses B.1 and B.2.
- 2) Connect the power measuring equipment to the ground/aircraft station antenna connector as shown in clause B.3.1.

5.3.8.2 Procedure

- 1) Set the received level to -90 dBm and confirm that the REQPERF is achieved.
- 2) Using the variable attenuator reduce the received signal level from -90 dBm while the REQPERF is within its specification.

5.3.8.3 Test requirement

- 1) Measure the received signal level.
- 2) The result obtained shall be compared to the limit in clause 4.2.8.2 in order to prove compliance.

5.3.9 Receiver Spurious Response

5.3.9.1 Initial conditions

- 1) Test environment: see clauses B.1 and B.2.
- 2) Set up the test system according to clause B.3.3.

5.3.9.2 Procedure

- 1) Adjust the signal generators to the type of interfering signals, levels and the frequency offsets as specified in table 18.
- 2) Measure the REFSENS.

5.3.9.3 Test requirement

The result obtained shall be compared with the limit in clause 4.2.9.2 in order to prove compliance.

5.3.10 Receiver Adjacent Channel Selectivity

5.3.10.1 Initial conditions

- 1) Test environment: see clauses B.1 and B.2.
- 2) Set up the test system according to clause B.3.3.

5.3.10.2 Procedure

- 1) Set the reference signal generator to the appropriate modulation (WCDMA or OFDMA).
- 2) Set the interfering signal generator modulation to the same type as that of the reference signal modulation.
- 3) Set the signal levels and bandwidths (as appropriate) according to table 18. The value of REFSENS is specified in clause 4.2.8.2.

Table 18: Receiver Adjacent Channel Selectivity Test Parameters

	Channel Bandwidth					
	1,4 MHz	3 MHz	5 MHz	10 MHz	15 MHz	20 MHz
Wanted Reference Signal (dBm)	REFSENS + 14 dB					
Interference Signal (dBm)	REFSENS + 4,5 dB	REFSENS + 45,5 dB	REFSENS + 45,5 dB	REFSENS + 45,5 dB	REFSENS + 45,5 dB	REFSENS + 45,5 dB
Interference Signal Bandwidth (MHz)	1,4	3	5	5	5	5
Interferer frequency offset (MHz)	± 1,4025	± 3,0075	± 5,0075	± 7,5075	± 10,0125	± 12,5

5.3.10.3 Test requirement

The REQPERF shall be achieved for all scenarios as specified in clause 4.2.10.2 in order to prove compliance.

5.3.11 Receiver Intermodulation Rejection

5.3.11.1 Initial conditions

- 1) Test environment: see clauses B.1 and B.2.
- 2) Set up the test system according to clause B.3.4.

5.3.11.2 Procedure

- 1) Adjust the signal generators to the type of interfering signals, levels and the frequency offsets as specified in table 10.
- 2) Measure the REQPERF.

5.3.11.3 Test requirement

The REQPERF shall be achieved for all scenarios as specified in clause 4.2.11.2 in order to prove compliance.

5.3.12 Receiver Blocking

5.3.12.1 Initial conditions

- 1) Test environment: see clauses B.1 and B.2.
- 2) Set up the test system according to clause B.3.3.

5.3.12.2 Procedure

- 1) Adjust the signal generators to the type of interfering signals, levels and the frequency offsets as specified in table 11.
- 2) The CW interfering signal shall be swept with a step size of 1 MHz within the specified range.
- 3) Measure the REQPERF.

5.3.12.3 Test requirement

The results obtained shall be compared to the limit in clause 4.2.12.2 in order to prove compliance.

5.3.13 Dedicated antennas

For testing antennas for compliance with technical requirements, ETSI EN 301 126-3-2 [1], clause 6.1 shall apply.

Annex A (normative): Relationship between the present document and the essential requirements of Directive 2014/53/EU

The present document has been prepared under the Commission's standardisation request C(2015) 5376 final [i.7] to provide one voluntary means of conforming to the essential requirements of Directive 2014/53/EU on the harmonisation of the laws of the Member States relating to the making available on the market of radio equipment and repealing Directive 1999/5/EC [i.1].

Once the present document is cited in the Official Journal of the European Union under that Directive, compliance with the normative clauses of the present document given in table A.1 confers, within the limits of the scope of the present document, a presumption of conformity with the corresponding essential requirements of that Directive, and associated EFTA regulations.

**Table A.1: Relationship between the present document
and the essential requirements of Directive 2014/53/EU**

Harmonised Standard ETSI EN 303 339				
The following requirements are relevant to the presumption of conformity under the article 3.2 of Directive 2014/53/EU [i.1]				
Requirement			Requirement Conditionality	
No	Description	Reference: Clause No	U/C	Condition
1	Spectrum Emission Mask	4.2.2	U	
2	Adjacent Channel Leakage power Ratio (ACLR)	4.2.3	U	
3	Transmitter spurious emissions	4.2.4	U	
4	Transmitter maximum output power	4.2.5	U	
5	Altitude attenuation factor - Aircraft Station	4.2.6	U	
6	Compatibility with BFWA - Aircraft Station	4.2.7	U	
7	Receiver Minimum Sensitivity	4.2.8	U	
8	Receiver Spurious Response	4.2.9	U	
9	Receiver Adjacent Channel Selectivity	4.2.10	U	
10	Receiver Intermodulation Rejection	4.2.11	U	
11	Receiver Blocking	4.2.12	U	
12	Dedicated Antennas Radiation Pattern Envelops	4.2.13	U	
13	Dedicated Antennas Gain Requirements	4.2.14	U	

Key to columns:

Requirement:

No A unique identifier for one row of the table which may be used to identify a requirement.

Description A textual reference to the requirement.

Clause Number Identification of clause(s) defining the requirement in the present document unless another document is referenced explicitly.

Requirement Conditionality:

U/C Indicates whether the requirement is to be unconditionally applicable (U) or is conditional upon the manufacturers claimed functionality of the equipment (C).

Condition Explains the conditions when the requirement shall or shall not be applicable for a requirement which is classified "conditional".

Presumption of conformity stays valid only as long as a reference to the present document is maintained in the list published in the Official Journal of the European Union. Users of the present document should consult frequently the latest list published in the Official Journal of the European Union.

Other Union legislation may be applicable to the product(s) falling within the scope of the present document.

Annex B (normative): Test specification

B.1 Normal test environment

When a normal test environment is specified for a test, the test shall be performed within the minimum and maximum limits of the conditions stated in table B.1.

Table B.1: Limits of conditions for Normal Test Environment

Condition	Minimum	Maximum
Barometric pressure	86 kPa	106 kPa
Temperature	15 °C	30 °C
Relative Humidity	20 %	85 %
Power supply	+28 Vdc or 115 Vac 400 Hz	
Vibration	Negligible	

B.2 RF Signals

B.2.1 Bandwidth

Unless otherwise stated, the bandwidth for test purposes shall be 10 MHz.

B.2.2 Channels

The available spectrum in each band is 20 MHz. Unless otherwise stated, the tests shall be conducted for both 10 MHz channels in each band.

B.3 Test Configurations

B.3.1 Maximum output power, transmitter spurious emissions and operating band unwanted emissions

The test configuration for maximum output power, transmitter spurious emissions and operating band unwanted emissions measurements is shown in figure B.1.

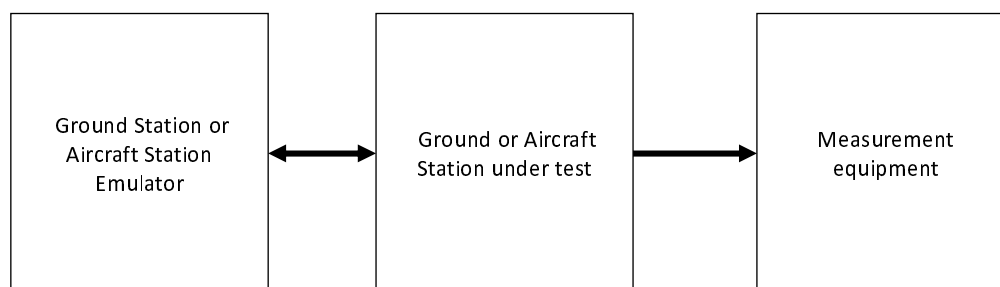

Figure B.1: Measuring system set-up for transmitter spurious emissions and operating band unwanted emissions and output power

B.3.2 Altitude Attenuation factor

The test configuration for altitude attenuation factor measurements is shown in figure B.2. The fixed attenuator shall be at least 80 dB with at least a 15 watt power rating. The variable attenuator shall have a range of at least 30 dB.

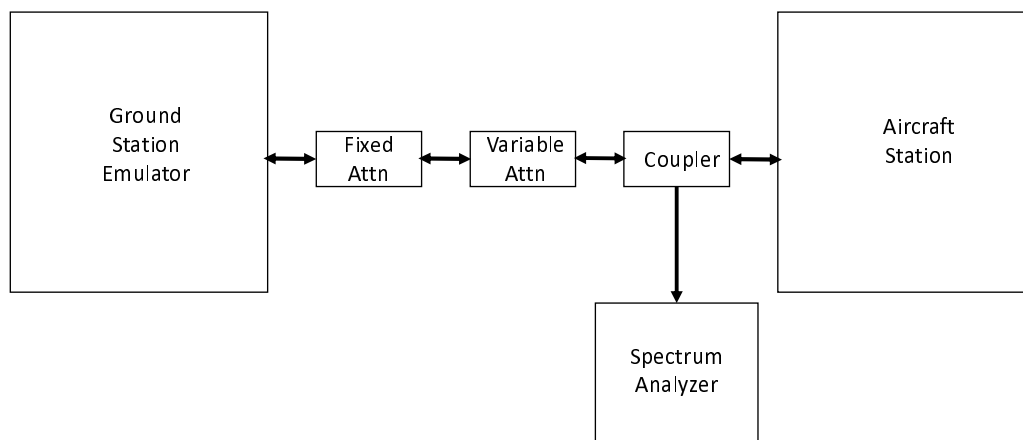

Figure B.2: Measurement system for the altitude attenuation factor

B.3.3 Receiver ACS, Blocking and Spurious

The test configuration for receiver ACS, blocking and spurious measurements is shown in figure B.3. The insertion loss of the combiner shall be calibrated and taken into account when making measurements.

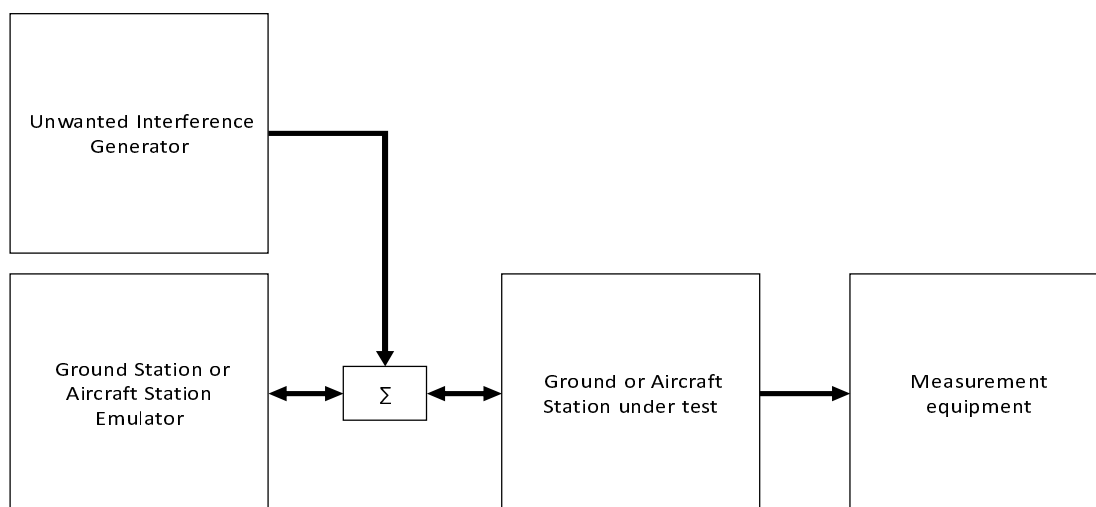

Figure B.3: Measurement system for receiver blocking

B.3.4 Receiver Intermodulation

The test configuration for receiver intermodulation measurements is shown in figure B.4. The insertion loss of the combiner shall be calibrated and taken into account when making measurements.

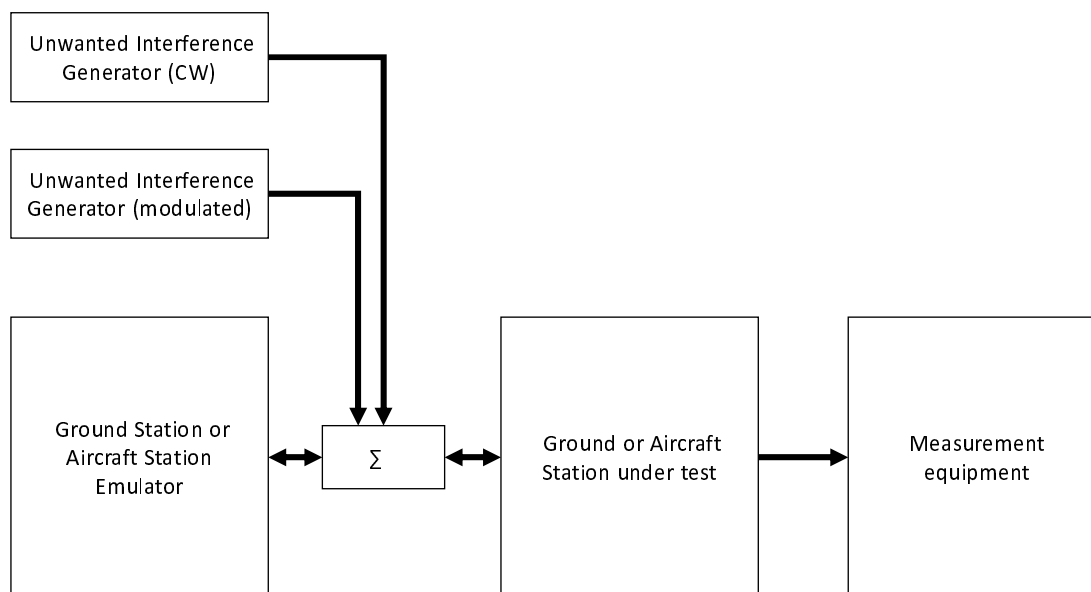

Figure B.4: Measurement system for receiver intermodulation

Annex C (informative): Environmental profile specification

The following environmental conditions may be declared by the manufacturer:

- barometric pressure: minimum and maximum;
- temperature: minimum and maximum;
- relative humidity: minimum and maximum;
- power supply: lower and upper voltage limit.

Annex D (normative): Geographical Data

D.1 Introduction

The equipment shall host geographical data which comprises a matrix grid of cells calibrated in latitude and longitude. Each cell dimension shall be 0,1 degree of arc (latitude) by 0,1 degree of arc (longitude). It shall include both terrain height and BFWA mitigation data. The terrain height shall be measured in metres and shall comply with the World Geodetic System 1984 (WGS84) [2]. The BFWA mitigation data shall specify for every cell whether or not mitigation is required.

The aircraft position shall be the "present position" in latitude and longitude.

The geographical data shall have no impact on safety.

D.2 Altitude determination

When available, the aircraft station shall use GNSS height to measure the height of the aircraft. However, if GNSS height is not available barometric altitude may be substituted.

The altitude shall be calculated for a given aircraft position as follows:

- $\text{Altitude} = \text{aircraft height} - \text{terrain height}$.

D.3 BFWA mitigation

The equipment shall consult the geographical data using the aircraft's position to determine whether or not BFWA mitigation is required.

D.4 Time currency

The equipment shall load and store the geographical data at least every seven days from a declared source. If the data cannot be refreshed within seven days the equipment shall assume the minimum altitude (3 000 m) and that BFWA mitigation is required.

Annex E (informative): Bibliography

Directive 2004/108/EC of the European Parliament and of the Council of 15 December 2004 on the approximation of the laws of the Member States relating to electromagnetic compatibility and repealing Directive 89/336/EEC (EMC Directive).

Directive 2006/95/EC of the European Parliament and of the Council of 12 December 2006 on the harmonisation of the laws of Member States relating to electrical equipment designed for use within certain voltage limits (LV Directive).

Annex F (informative): Change History

Version	Information about changes
1.1.1	First published version.

History

Document history			
V1.0.4	December 2015	EN Approval Procedure	AP 20160323: 2015-12-24 to 2016-03-23
V1.1.0	April 2016	Vote	V 20160621: 2016-04-22 to 2016-06-21