

Draft **ETSI EN 303 215** V1.2.11 (2014-12)



EUROPEAN STANDARD

**Environmental Engineering (EE);
Measurement methods and limits for power consumption in
broadband telecommunication networks equipment**

Reference

REN/EE-EEPS008

Keywords

broadband, energy efficiency, power supply

ETSI

650 Route des Lucioles
F-06921 Sophia Antipolis Cedex - FRANCE

Tel.: +33 4 92 94 42 00 Fax: +33 4 93 65 47 16

Siret N° 348 623 562 00017 - NAF 742 C
Association à but non lucratif enregistrée à la
Sous-Préfecture de Grasse (06) N° 7803/88

Important notice

The present document can be downloaded from:

<http://www.etsi.org>

The present document may be made available in electronic versions and/or in print. The content of any electronic and/or print versions of the present document shall not be modified without the prior written authorization of ETSI. In case of any existing or perceived difference in contents between such versions and/or in print, the only prevailing document is the print of the Portable Document Format (PDF) version kept on a specific network drive within ETSI Secretariat.

Users of the present document should be aware that the document may be subject to revision or change of status. Information on the current status of this and other ETSI documents is available at

<http://portal.etsi.org/tb/status/status.asp>

If you find errors in the present document, please send your comment to one of the following services:

http://portal.etsi.org/chaicor/ETSI_support.asp

Copyright Notification

No part may be reproduced or utilized in any form or by any means, electronic or mechanical, including photocopying and microfilm except as authorized by written permission of ETSI.

The content of the PDF version shall not be modified without the written authorization of ETSI.

The copyright and the foregoing restriction extend to reproduction in all media.

© European Telecommunications Standards Institute 2014.

All rights reserved.

DECT™, **PLUGTESTS™**, **UMTS™** and the ETSI logo are Trade Marks of ETSI registered for the benefit of its Members. **3GPP™** and **LTE™** are Trade Marks of ETSI registered for the benefit of its Members and of the 3GPP Organizational Partners.

GSM® and the GSM logo are Trade Marks registered and owned by the GSM Association.

Contents

Intellectual Property Rights	4
Foreword.....	4
Modal verbs terminology.....	4
Introduction	4
1 Scope	5
2 References	5
2.1 Normative references	5
2.2 Informative references.....	6
3 Definitions and abbreviations.....	6
3.1 Definitions.....	6
3.2 Abbreviations	7
4 Definition of power consumption.....	8
4.1 Definition of power consumption per port of broadband network equipment	8
4.2 Power consumption taking into account the low-power states	8
5 Measurement methods.....	9
5.1 General requirements	9
5.1.1 Measurement conditions	9
5.1.2 Measurement instruments requirements	9
5.1.3 Considered equipment	10
5.1.4 Not considered equipment	10
5.1.5 Measurement reference points	11
5.1.6 Traffic profile.....	11
5.2 Measurement method for DSLAM/MSAN equipment	11
5.2.1 Equipment configuration	11
5.2.2 Reference measurement method	13
5.3 Measurement method for OLT equipment	14
5.3.1 Equipment configuration	14
5.3.2 Reference measurement method	15
5.4 Alternative measurement method.....	15
5.5 Reporting of the measurements	16
Annex A (informative): Example hourly traffic distribution profiles	18
Annex B (informative): NPC definition and calculation examples	19
Annex C (informative): Measurement power consumption for DSLAM/MSAN and OLT equipment for different number of active ports.....	20
History	21

Intellectual Property Rights

IPRs essential or potentially essential to the present document may have been declared to ETSI. The information pertaining to these essential IPRs, if any, is publicly available for **ETSI members and non-members**, and can be found in ETSI SR 000 314: "*Intellectual Property Rights (IPRs); Essential, or potentially Essential, IPRs notified to ETSI in respect of ETSI standards*", which is available from the ETSI Secretariat. Latest updates are available on the ETSI Web server (<http://ipr.etsi.org>).

Pursuant to the ETSI IPR Policy, no investigation, including IPR searches, has been carried out by ETSI. No guarantee can be given as to the existence of other IPRs not referenced in ETSI SR 000 314 (or the updates on the ETSI Web server) which are, or may be, or may become, essential to the present document.

Foreword

This draft European Standard (EN) has been produced by ETSI Technical Committee Environmental Engineering (EE), and is now submitted for the combined Public Enquiry and Vote phase of the ETSI standards EN Approval Procedure.

Proposed national transposition dates	
Date of latest announcement of this EN (doa):	3 months after ETSI publication
Date of latest publication of new National Standard or endorsement of this EN (dop/e):	6 months after doa
Date of withdrawal of any conflicting National Standard (dow):	6 months after doa

Modal verbs terminology

In the present document "**shall**", "**shall not**", "**should**", "**should not**", "**may**", "**may not**", "**need**", "**need not**", "**will**", "**will not**", "**can**" and "**cannot**" are to be interpreted as described in clause 3.2 of the [ETSI Drafting Rules](#) (Verbal forms for the expression of provisions).

"**must**" and "**must not**" are **NOT** allowed in ETSI deliverables except when used in direct citation.

Introduction

The present document defines the energy consumption metrics and measurement methods for fixed broadband telecommunication network equipment.

1 Scope

The present document defines the power consumption metrics, the methodology and the test conditions to measure the power consumption of broadband fixed telecommunication networks equipment. The present document does not cover all possible configuration of equipment but only homogenous configurations.

The types of broadband access technologies covered by the present document are the ones widely deployed at the date of publication. Currently, the present document considers DSLAM DSL, MSAN, GPON OLT and Point to Point OLT equipment. Other access technologies may be included in further versions of the present document.

The present document also considers measurement methodology for VDSL2 equipment with vectoring functionality.

In addition to the full power state, power-saving states as defined in DSL standards [i.1] and [i.2] are also covered.

The present document focuses on Network Equipment. The end-user equipment will be handled in another document.

2 References

References are either specific (identified by date of publication and/or edition number or version number) or non-specific. For specific references, only the cited version applies. For non-specific references, the latest version of the referenced document (including any amendments) applies.

Referenced documents which are not found to be publicly available in the expected location might be found at <http://docbox.etsi.org/Reference>.

NOTE: While any hyperlinks included in this clause were valid at the time of publication, ETSI cannot guarantee their long term validity.

2.1 Normative references

The following referenced documents are necessary for the application of the present document.

- [1] ETSI TS 101 388: "Access Terminals Transmission and Multiplexing (ATTM); Access transmission systems on metallic access cables; Asymmetric Digital Subscriber Line (ADSL) - European specific requirements [ITU-T Recommendation G.992.1 modified]".
- [2] ETSI EN 300 132-2: "Environmental Engineering (EE); Power supply interface at the input to telecommunications and datacom (ICT) equipment; Part 2: Operated by -48 V direct current (dc)".
- [3] ETSI TS 101 271 (V1.1.1): "Access Terminals Transmission and Multiplexing (ATTM); Access transmission system on metallic pairs; Very High Speed digital subscriber line system (VDSL2); [ITU-T Recommendation G.993.2 modified]".
- [4] Void.
- [5] ETSI ES 201 970: "Access and Terminals (AT); Public Switched Telephone Network (PSTN); Harmonized specification of physical and electrical characteristics at a 2-wire analogue presented Network Termination Point (NTP)".
- [6] Recommendation ITU-T G.984: "Gigabit-capable passive optical networks (GPON)".
- [7] Recommendation ITU-T G.984.2: "Gigabit-capable Passive Optical Networks (G-PON): Physical Media Dependent (PMD) layer specification".
- [8] IEEE 802.3: "IEEE Standard for Information technology -- Telecommunications and information exchange between systems -- Local and metropolitan area networks -- Specific requirements -- Part 3: Carrier Sense Multiple Access with Collision Detection (CSMA/CD) Access Method and Physical Layer Specifications".
- [9] Broadband Forum TR-100: "ADSL2/ADSL2plus; Performance Test Plan".

- [10] Broadband Forum TR-114: "VDSL2 Performance Test Plan".

2.2 Informative references

The following referenced documents are not necessary for the application of the present document but they assist the user with regard to a particular subject area.

- [i.1] Recommendation ITU-T G.992.3 (2005): "Asymmetric digital subscriber line transceivers 2 (ADSL2)".
- [i.2] Recommendation ITU-T G.992.5 (2005): "Asymmetric Digital Subscriber Line (ADSL) transceivers - Extended bandwidth ADSL2 (ADSL2plus)".
- [i.3] Recommendation ITU-T G.993.2 (2006): "Very high speed digital subscriber line 2 (VDSL2)".
- [i.4] ETSI TR 102 530: "Environmental Engineering (EE); The reduction of energy consumption in telecommunications equipment and related infrastructure".
- [i.5] Broadband Forum TR-202: "ADSL2/ADSL2plus Low-Power Mode Guidelines".
- [i.6] Void.
- [i.7] IEC 60050: "International Electrotechnical Vocabulary - Electrical and electronic measurements and measuring instruments - Part 311: General terms relating to measurements - Part 312: General terms relating to electrical measurements - Part 313: Types of electrical measuring instruments - Part 314: Specific terms according to the type of instrument".

NOTE: Available at <http://webstore.iec.ch/webstore/webstore.nsf/artnum/027448!opendocument>.

- [i.8] IEC 62018: "Power consumption of information technology equipment - Measurement methods".

NOTE: Equivalent to CENELEC EN 62018.

3 Definitions and abbreviations

3.1 Definitions

For the purposes of the present document, the following terms and definitions apply:

accuracy (of a measuring instrument): quality which characterizes the ability of a measuring instrument to provide an indicated value close to a true value of the measurand

NOTE 1: This term is used in the "true value" approach.

NOTE 2: Accuracy is all the better when the indicated value is closer to the corresponding true value.

NOTE 3: See IEC 60050 [i.7], definition (311-06-08).

active line: line in operational mode and carrying traffic as specified for that mode of operation (ADSL2plus or VDSL2)

broadband telecommunication network equipment: equipment of broadband technology that is part of a telecommunication network

broadband terminal equipment: equipment of broadband technology that is connected beyond the Network Termination Point of a telecommunication network

full-power state: state in which the maximal allowed data transmission is possible

NOTE: The maximum is defined by the physical properties of the line and the settings of the operator (e.g. L0 for ADSL2/2plus).

low-power state: state in which a limited power reduction capability and a limited data transmission is allowed

NOTE: It is entered automatically from the full power state after the data transmission during a certain time is lower than the limit. If more than the limited data has to be transmitted from either side a state change to the full power state is entered automatically. The low power state may comprise multiple sub-states with history dependant state transition rules (e.g. L2 for ADSL2/2plus).

power consumption: power used by a device to achieve an intended application performance

stand-by state: state in which the largest power reduction capability and no transmission of data is possible

NOTE: From this state a direct state change to the full-transmission state is possible, if data has to be transmitted from either side (e.g. L3 for ADSL2/2plus).

telecommunication network: network operated under a license granted by a national telecommunications authority, which provides telecommunications between Network Termination Points (NTPs) (i.e. excluding terminal equipment beyond the NTPs)

3.2 Abbreviations

For the purposes of the present document, the following abbreviations apply:

AC	Alternative Current
ADSL	Asymmetric Digital Subscriber Line
ADSL2plus	Second generation ADSL with extended bandwidth
BBF	Broadband Forum
CPE	Customer Premises Equipment
DBA	Dynamic Bandwidth Allocation
DC	Directive Current
DPBO	Downstream Power Back-Off
DSL	Digital Subscriber Line
DSLAM	Digital Subscriber Line Access Multiplexer
DSM	Dynamic Spectrum Management
GPON	Gigabit Passive Optical Network
IP	Internet Protocol
MAC	Media Access Control
MELT	Metallic Loop Test
MIMO	Multiple Input Multiple Output
MPLS	Multiprotocol Label Switching
MSAN	Multi Service Access Node
NPC	Normalized Power Consumption
OLT	Optical Line Termination
ONU	Optical Network Unit
POTS	Plain Old Telephone Service
PSTN	Public Switched Telephone Network
QoS	Quality of Service
SNR	Signal Noise Ratio
SOHO	Small Office/Home Office
UPBO	Upstream Power Back-Off
VAC	Ventilation Air Conditioning
VDSL	Very high speed Digital Subscriber Line
VDSL2	second generation VDSL
VLAN	Virtual Local Area Network

4 Definition of power consumption

4.1 Definition of power consumption per port of broadband network equipment

The power consumption of broadband telecommunication network equipment is defined as:

$$P_{\text{BBport}} = P_{\text{BBeq}} / N_{\text{ports}}$$

Where:

P_{BBeq} is the power consumption (in W) of a fully equipped broadband network equipment, measured at the electric power input interface, placed at the premises of the operator or the equipment supplier, which connects multiple broadband subscribers to a backbone. P_{BBeq} is measured in determined environmental conditions defined in clause 5.1.1.

P_{BBport} is the power consumption per port in W of the broadband network equipment for which the limits are defined in the present document.

N_{ports} is the maximum number of subscriber lines access ports served by the broadband network equipment under test.

4.2 Power consumption taking into account the low-power states

The low-power states are intended to reduce the power consumption during periods of no or minimal traffic needs (e.g. low data-rate applications or control signalling only). When these low-power states are used, the achievable power consumption reduction can be estimated by using profiles based on user traffic assumptions, some example of user hourly traffic as illustrated in annex A.

NOTE 1: Example of power-saving states usage.

A number of power-saving states are defined in the DSL standards (L2, L3, Recommendations ITU-T G.992.3 [i.1] and G.992.5 [i.2]). These power-saving states are implemented, both in the Network equipment (i.e. the subject of the present document) and the CPE/end-user equipment deployed at the premises of the user of the broadband line; this will enable the operator to use these to further limit the power consumption of the equipment. Further study is required to optimize the way in which the low-power states are controlled. In particular, to determine the levels of interference that might arise due to the fluctuating crosstalk caused by frequent multi-state power transitions.

It is important to notice that it is only possible for GPON to use stand-by state if all ONU are in stand-by state and not individually as possible for Point-to-Point transmission.

NOTE 2: Additional power saving solutions. A number of additional power saving solutions are available. Some of these are listed below. However the list is not complete and both the developers and users of broadband network equipment are encouraged to investigate and introduce new power saving solutions:

- Politeness algorithms.
- Dynamic Spectrum Management.
- Boards optimized for remote applications (reduced line power).
- Dynamic power saving for unused components such as line card, chipset, port, etc.

5 Measurement methods

This clause describes the methods to measure the power consumption of broadband network equipment and also gives the conditions under which these measurements shall be performed.

5.1 General requirements

5.1.1 Measurement conditions

The power measurements shall be performed in a laboratory environment under the following conditions:

- Room Temperature: $25\text{ °C} \pm 2\text{ °C}$.
- Room Relative Humidity: 30 % to 75 %.
- Operating voltage:
 - DC Powered Equipment: According to ETSI EN 300 132-2 [2], $-54,5\text{ V} \pm 1,5\text{ V}$ for nominal voltage of -48 V DC powered equipment. Equipment using voltage other than -48 V DC shall be tested at $\pm 1\%$ of the nominal voltage.
 - AC Powered Equipment: $230\text{ V} \pm 1\%$ for nominal voltage of 230 V AC and frequency $50\text{ Hz} \pm 1\%$.
- Minimum Measurement Duration: Equipment shall be allowed to stabilize to get stable power measurement. If power varies over the measurement interval time, an average of measurement shall be calculated:
 - For DSLAM equipment, wait 1 minute to settle bitswap after entering L0 mode. After entering L2 mode, wait one more minute after achieving the final trimmed power level.
 - For OLT equipment, wait till OLT and the connected ONUs have finished ranging and dynamic bandwidth allocation (DBA). The DBA will ensure that any unused bandwidth on a specific GPON port is allocated to the ONUs connected to it.

5.1.2 Measurement instruments requirements

All measurement instruments used should be calibrated by counterpart national metrology institute and within calibration due date:

- Power Source: Power sources used to provide power to the equipment under test shall be capable of providing a minimum of 1,5 times the power rating of the equipment under test.
- Input power:
 - Resolution: $\leq 10\text{ mA}$; $\leq 100\text{ mV}$; $\leq 100\text{ mW}$
 - DC current: $\pm 1\%$
 - DC voltage: $\pm 1\%$
 - AC power: $\pm 1\%$:
 - An available current crest factor of 5 or more
 - The test instrument shall have a bandwidth of at least 1 kHz

NOTE 1: Measurement equipment with higher digitizing rates and higher accuracy may be desirable to ensure accurate measurement.

NOTE 2: Additional information on accuracy can be found in IEC 62018 [i.8].

5.1.3 Considered equipment

The following items are considered part of the broadband network equipment and therefore their power consumption shall be taken into account to get the total power consumption (P_{BBeq}) of the broadband network equipment:

- Network Termination board, providing one or more links to the Core or Backhaul Network.

NOTE: The actual number of links should reflect the normal resilience practice for that type of equipment. Furthermore, all uplink ports should carry test traffic averaged or approximatively averaged.

- Line Termination board, providing a number of DSL, POTS, GPON or Point to Point Ethernet ports connected to the end-user through the metallic lines or optical fibre.
- Backplane (or other) to interconnect the different blocks of the broadband network equipment.
- Inside Rack Cooling system (e.g. fans drawer inside cabinet based broadband systems).
- Normal operational power supply unit.

5.1.4 Not considered equipment

The following items are not considered part of the broadband network equipment and therefore their power consumption shall not be added to the power consumption of the broadband network equipment:

- External rectifier (AC - DC converter).
- Room or outdoor Cabinet Ventilation and Air Conditioning Unit (VAC Unit).
- Auxiliary or redundant power unit.
- Battery.
- For DSLAM equipment, Additional External signal processing (Dynamic Spectrum Management (DSM) and Multiple Input Multiple Output (MIMO) techniques if not implemented as part of the Line Termination board).

For those boards which have more than the bare DSL functionality but have additional functions (e.g. MELT, vectoring, test access and channel bonding, etc.), these boards are to be used in normal DSL mode of operation with such additional functions disabled. Optionally a measurement with these functions enabled can be described/requested. In case such additional functions cannot be fully disabled, manufacturer will declare what is the extra power budget due to the added functionality. Such extra budget will not be considered in P_{BBport} .

5.1.5 Measurement reference points

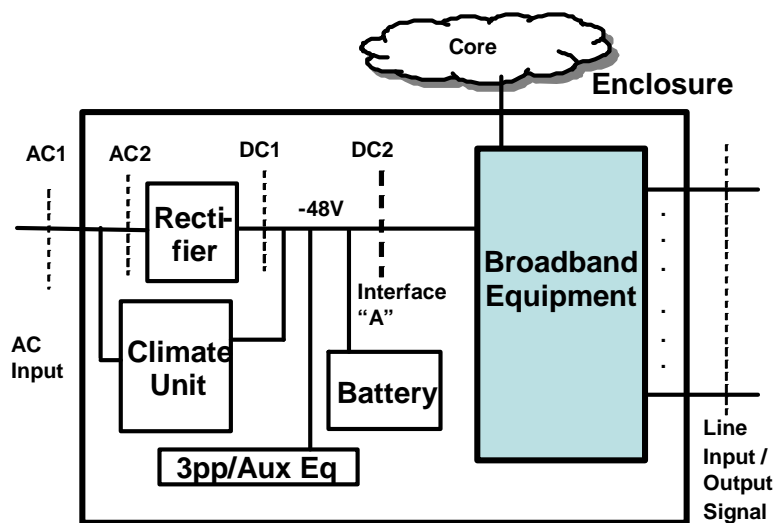

Figure 1: Broadband Node site reference model

The power consumption requirements of the present document apply at Interface "A" [2] as shown in figure 1 (i.e. at the point DC2 for the configuration in figure 1).

5.1.6 Traffic profile

Definition of Ethernet traffic:

- Bridge mode.
- Random variable packet size distribution from 64 octets to 1 518 octets (bytes).
- Traffic rates limited to 80 % of net activation rate (takes overhead into account).

Traffic shall flow in both directions, but due in case of Upstream and Downstream possible asymmetry, loop-back mode is not allowed except for Point-to-Point OLT.

5.2 Measurement method for DSLAM/MSAN equipment

In the present document only homogenous configuration are measured. Mixed configuration (e.g. DSLAM with a mix of ADSL2/2plus, VDSL2 and optical interfaces) are not considered.

5.2.1 Equipment configuration

DSLAM/MSAN equipment shall be configured as defined below. Active lines shall be carrying traffic over an ETSI loop 1, as defined in ETSI TS 101 388 [1] and ETSI TS 101 271 [3], without any additional noise. The loop length is dependent on the DSL technology (see Recommendations ITU-T G.992.3 [i.1], G.992.5 [i.2] and G.993.2 [i.3]) activated on the line. The test set-up is as shown in figure 2.

Equipment conditions:

- ADSL2plus configuration:
 - Loop length/type: see table 1.
 - Full power state is configured as follows:
 - Common line settings: as defined in BBF TR-100, table 7-1 [9].
 - General test profile: F-1/0 as defined in BBF TR-100, table 7-2 [9].

- Specific test Profile: A2P_RA_F_30000k as defined in BBF TR-100, table 7-3 [9].
- DPBO shall be off.
- Low power state is configured as following:
 - PMMODE: L2 state enabled (Low power state).
 - L0-TIME: as defined in BBF TR-100, table B.2-25 [9].
 - L2-TIME: as defined in BBF TR-100, table B.2-25 [9].
 - L2-ATPR: 1 dB.
 - L2-ATPRT: in the range -1 dB to -31 dB. Manufacturer shall declare the minimum L2-ATPRT value necessary to respect the requirements of table A.1.

NOTE 1: L2-ATPRT parameter defines the total maximum aggregate transmit power reduction that is allowed in L2 state. As such matching L2 power consumption targets with L2 value close to -1 dB is better (higher efficient) than matching the same targets but with L2 value close to -31 dB.

- L2-MinDatarate: ≥ 128 kbps.

NOTE 2: For real network implementation a reference for the setting can be found in BroadBand Forum documents TR-202 [i.5], for example L2 ATPRT ≤ 10 dB.

- VDSL2 configuration:
 - Loop-length/type: see table 1.
 - Common line settings: as defined in BBF TR-114, table 11 [10].
 - General line settings: I-8/2 as defined in BBF TR-114, table 12 [10].
 - Specific test Profile: RA_I_150_150 as defined in BBF TR-114, table 13 [10].
 - Both DPBO and UPBO shall be off.
- VDSL2 configuration with vectoring functionality enabled:
 - Loop-length/type: see table 1.
 - Common line settings: as defined in BBF TR-114, table 11 [10].
 - General line settings: I-8/2 as defined in BBF TR-114, table 12 [10].
 - Specific test Profile: RA_I_150_150 as defined in BBF TR-114, table 13 [10].
 - Both DPBO and UPBO shall be off.
 - The DSLAM is configured for VDSL2 operation with upstream and downstream vectoring enabled on all its lines. For the configured profile, the DSLAM operates on all its lines at its maximum supported transmit power and over the widest frequency bands over which it supports vectoring. The DSLAM operates at its maximum cancellation capabilities in terms of number of cancelled disturbers and of SNR improvement gained with cancellation.

Table 1: Loop-lengths for various DSL technologies

Technology	Loop length	Reference loop	Reference document
ADSL2plus	2 500 m	ETSI TS 101 388 [1] loop#1	BBF TR-100, table A.2-19 [9]
VDSL2 profile 8a, 8b, 8d	1 200 m	ETSI PE04	BBF TR-114, table 57 [10]
VDSL2 profile 8c	1 200 m	ETSI TP100	BBF TR-114, table 85 [10]
VDSL2 profile 12a, 12b	450 m	ETSI PE04	BBF TR-114, table 59 [10]
VDSL2 profile 17a	450 m	ETSI PE04	BBF TR-114, table 61 [10]
VDSL2 profile 30a	150 m	ETSI PE04	

NOTE: The above DSL technologies and profiles are defined for the power consumption measurement. Representative loop lengths for the corresponding DSL technologies and profiles are also defined in this table. The worst case VDSL2 configurations are the configurations for profile 8b, 17a and 30a. Other loop types and loop lengths may be used if resulting in the same insertion loss at 300 kHz for ADSL2plus and 1 MHz for VDSL2.

- MSAN configuration:
 - Broadband(DSL) circuit power consumption are as measured for the DSLAM configuration.
 - Only narrowband(voice) circuit is present in measured configuration, with POTS interfaces so configured as follows:
 - Loop current is from min 20 mA to max 40 mA according to ETSI ES 201 970 [5] (see table A.2).
 - Loop length is 3 km of 0,4 mm gauge or a loop resistance of 510 ohm, and CPE resistance is assumed to be zero.
 - Refer to table A.2 for port status.
 - Total power consumption of MSAN port (consisting of Voice and Broadband) is the sum of power consumption of the narrowband and broadband circuits.

5.2.2 Reference measurement method

**Figure 2: Test Setup for power measurement for DSLAM**

Figure 2 shows the basic test setup, which is to be used during the power measurements. Both the network side (optionally through an Ethernet switch) and the end-user side (direct or also through an Ethernet switch) are connected to an Ethernet Traffic Simulator/Analyzer.

For the reference measurement method, the broadband network loop simulator should be a cable with length in line with the requirements shown in table 1 or an artificial line simulator giving the same insertion loss of the physical cable.

For the test of equipment with vectoring functionality enabled, the test shall be done without the use of artificial line simulator.

The specification of this artificial line simulator is currently under study.

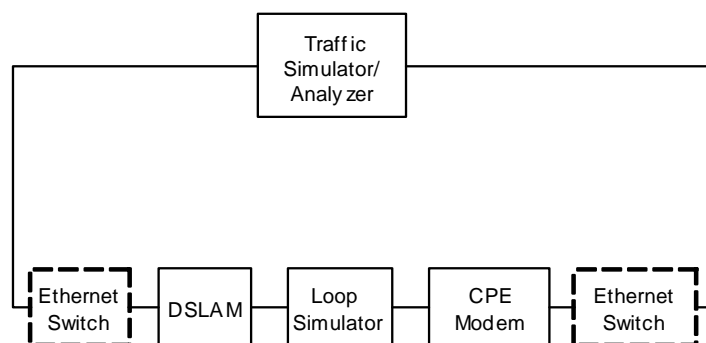
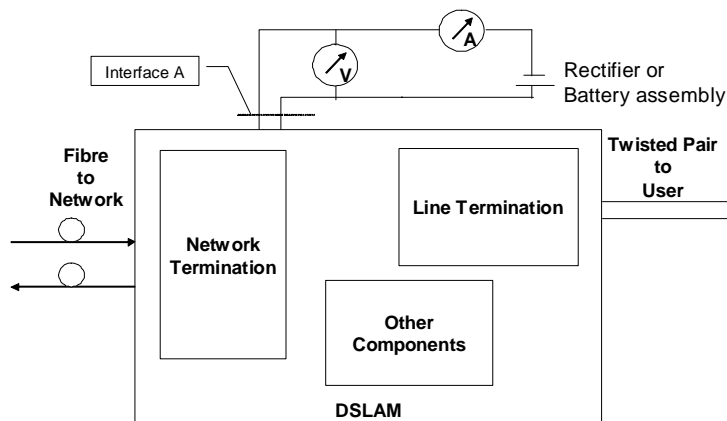

Figure 3: Power Consumption measurement at System level

In figure 3, the actual DSLAM power measurement method is shown. The DSLAM comprises the line termination boards, the Network termination boards and some other components like the cooling system. The Network termination board has fibre connections to the traffic simulator/analyzer (as shown in figures 2 and 3) and the line termination boards have twisted pairs connected to loop/line simulators.

The power consumption (P_{BBeq}) of the system under different power states (Full power state, Low power state and Standby State) is measured at the interface "A" of the DSLAM using power measurement instruments. The system can be powered either through a battery assembly or rectifier set at the nominal voltage as described in clause 5.1.1. For AC powered equipment, Real Power, Apparent Power and Power Factor should be accurately measured.

5.3 Measurement method for OLT equipment

5.3.1 Equipment configuration

OLT equipment shall be fully equipped with maximum configuration as defined below. The ports are activated and carry traffic. The test set-up is as shown in figure 4.

- GPON OLT configuration:
 - Compliance with Recommendation ITU-T G.984 [6].
 - Downstream data-rate is 2,488 Gbps and upstream data-rate is 1,244 Gbps.
 - Configured with ClassB+ (Recommendation ITU-T G.984.2 [7]) optical modules.
 - Each port of Line termination board is directly connected to one ONU with a 15 dB attenuator, but without splitter. The ONU will typically provide sufficient capacity to fully load the GPON interface with the OLT. It should be verified that the selected ONU is configured such that the upstream bandwidth can be filled by the ONU and that the downstream bandwidth coming from OLT can be fully processed.
 - Typical features: standard Layer-2 (Ethernet) aggregation functionalities, MAC address management, VLAN management, Multicast. For equipment with network layer functionalities, other features including static and dynamic routing protocols, MPLS, IP QoS.
- Point to Point OLT configuration:
 - Point to point OLT is directly connected to Customer Premises Equipment without cascading switch.
 - The optical budget for the interfaces shall be in line with IEEE 802.3 [8], clause 58 for the 100Base-LX10 and 100Base-BX10 interfaces and IEEE 802.3 [8], clause 59 for the 1000Base-LX10 and 1000Base-BX10 interfaces.
 - Typical features: Layer-2 (Ethernet) protocol management and network layer functionalities including static and dynamic routing protocols, MPLS, IP QoS.

5.3.2 Reference measurement method

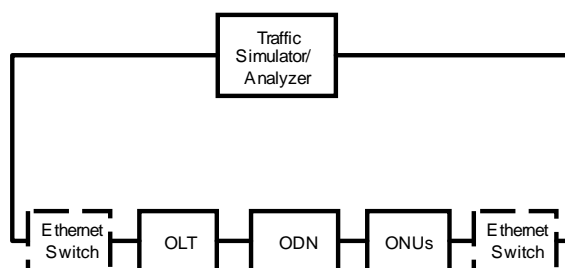

Figure 4: Test Setup for power measurement for OLT

Figure 4 shows the basic test setup, which is to be used during the power measurements. Both the network side (optionally through an Ethernet switch) and the end-user side (direct or also through an Ethernet switch) are connected to an Ethernet Traffic Simulator/Analyzer.

For the reference measurement method the broadband network equipment shall be fully equipped. All ports of the OLT shall be directly connected to one ONU through Class B+ optical module and a 15 dB attenuator but without splitter or cascading switch. The equipment is configured properly such that traffic generated by the Traffic Simulator can flow properly through the equipment to the ONU and vice versa. The Traffic Analyzer will show that the traffic is indeed passing through the setup.

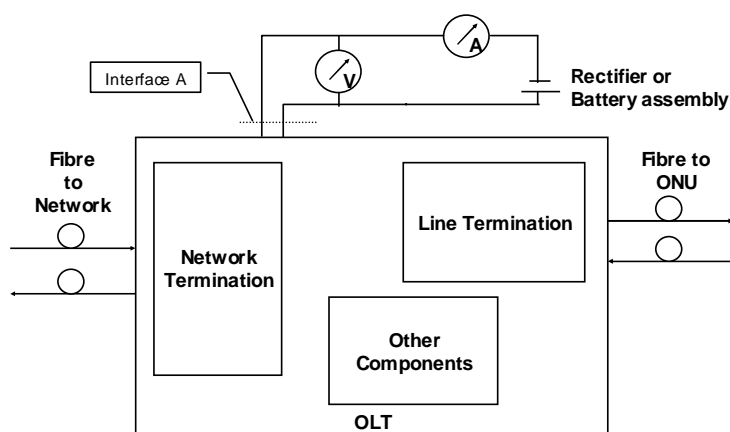

Figure 5: Power Consumption measurement at System level

In figure 5, the actual equipment power measurement method is shown. The equipment comprises the line termination boards, the Network termination boards and some other components like the cooling system. The Network termination board has fibre connections to the traffic simulator/analyzer (as shown in figures 4 and 5) and the line termination boards have fibres connected to ONU.

The power consumption (P_{BBeq}) of the system is measured at the interface "A" of the equipment using power measurement instruments. The system can be powered either through a battery assembly or rectifier set at the nominal voltage as described in clause 5.1.1. For AC powered equipment, Real Power, Apparent Power and Power Factor should be accurately measured.

5.4 Alternative measurement method

This alternative technique reduces the number of line simulators and CPE or ONU required but requires extrapolation to give the correct per line result. A minimal configuration shall include at least one fully equipped Line Termination board connected to end-user equipments and configured to pass traffic.

This alternative measurement method comprises two phases:

- The power consumption (P_{empty}) of the equipment is first measured without any Line Termination board based on figure 3 and figure 5 setup.
- In a second phase, for DSLAM, one Line Termination board is added to the system with all lines connected to a CPE through line or loop simulators. For OLT, one Line Termination board is added to the system with all lines connected to ONU through fibre. All parameters are set based on values shown in clauses 5.2.1 and 5.3.1. The power consumption ($P_{1 \text{ line card}}$) of the equipment with the added Line Termination board is measured once again and the difference ($P_{1 \text{ line card}} - P_{\text{empty}}$) gives the power consumption ($P_{\text{line card}}$) of a fully equipped Line Termination board.

NOTE: During both measurements (P_{empty} and $P_{1 \text{ line card}}$), it is important that the functional blocks, expected to have a power consumption varying with the number of users connected, are forced in a full load condition. Functional blocks which are known to increase power consumption under heavy load are the cooling system and the Network Termination board.

The total power consumption is given by the formula:

$$P_{\text{BBeq}} = P_{\text{empty}} + n \times P_{\text{line card}}$$

Where n is the maximum number of Line Termination boards per equipment.

5.5 Reporting of the measurements

The following details shall be included in the power measurement report:

- System configuration:
 - List of hardware items used in the system under test, showing both the vendor type number and serial number.
 - List of software/firmware modules used in the system.
 - The number of active line boards and ports.
 - The status and number of all end-user interfaces, including line length, line configuration and actual data rate.
- Measurement instruments:
 - List of measurement instruments used to measure the power consumption, including calibration information.
 - List of the CPE (DSL modem or ONU) used for the measurement.
- Measurement conditions:
 - Room temperature.
 - Relative humidity.
 - Actual operating voltage.
- Measurement results:
 - Power consumption: $P_{\text{BBeq}}, P_{\text{BBport}}$

NOTE 1: $P_{\text{empty}}, P_{1 \text{ line card}}, P_{\text{line card}}$ should also be reported if the alternative measurement method defined in clause 5.4 is used.

NOTE 2: For DSLAM equipment, power consumptions should be included for different power states (full power state, low power state, standby state).

NOTE 3: For AC powered equipment, Real Power, Apparent Power and Power Factor should be reported.

Annex A (informative): Example hourly traffic distribution profiles

The 24-hour time distribution over the states is based on the estimated typical traffic behaviour for a variety of user types. These traffic profiles are just examples and they might or might not be representative for an actual network.

NOTE: Further study is required to understand the effects of fluctuating crosstalk caused by systems transitioning between the L2/L3 and L0 states. This will potentially cause degradation in the performance of rate adaptive ADSL systems and therefore operators may decide to constrain the number of state transitions, which would result in a system spending longer in higher power modes.

Table A.1: Example DSLAM operational states L0-L2-L3 and 24-hour traffic model

User Type	L0 Time/Day (i.e. Full power state-time/day)	L2 Time/Day (i.e. Low power state-time/day)	L3 Time/Day (i.e. Standby state/day)
Private DSL	1 hour	1 hour	22 hours
Private triple play/SOHO	6 hours	2 hours	16 hours
Average	3,5 hours	1,5 hours	19 hours

Other traffic model, reported in table A.2, shows an alternative model with different time distribution.

Table A.2: Example DSLAM operational states L0-L2-L3 and 24-hour traffic model

User Type	L0 Time/Day (i.e. Full power state-time/day)	L2 Time/Day (i.e. Low power state- time/day)	L3 Time/Day (i.e. Standby state/day)
Private DSL	2 hours	22 hours	0
Private triple play/SOHO	8 hours	16 hours	0
Average	5 hours	19 hours	0

Annex B (informative): NPC definition and calculation examples

In addition to the power consumption P_{BBport} that is defined for the equipment, an indication of global network power performance "Normalized Power Consumption" (NPC) might be given. The definition of the NPC can be found in ETSI TR 102 530 [i.4].

For DSLAM equipment, the NPC is an indicator of the amount of power required to transport 1 Mbps of data over a predefined reference lengths in table 1, it is based on the bitrate and reach at full-power state as defined in the measurement method (see clause 5.2).

For OLT equipment, the NPC is an indicator of the amount of power required to transport 1 Mbps. Since the power consumption of OLT is not directly related with optical fibre length, no reference optical fibre length is defined.

$$\text{NPC} = 1\,000 \times P_{\text{BBport}} / \text{bitrate}$$

NPC is expressed in mW/Mbps. Bitrate is the downstream net data rate expressed in Mbps.

This NPC enables comparison of same technologies from different equipments and/or vendors, as well as of similar technologies such as evolutions or extensions (e.g. VDSL2 Vectoring) regarding the efficiency of transporting information (in terms of power). It is calculated at relevant reference loop lengths for each technology, and as such it should be clear that using NPC to directly compare technologies which use different reference loops or different access technologies should not be promoted. These reference loops are derived from the typical or targeted working conditions of these technologies and are given in the clause on measurement methods (clause 5.2.2).

NOTE: Using the NPC to compare the different working states (e.g. L0 with L2 or L3) is not recommended as the intention of some of these working states is to save energy at times of no or low-rate transmission, i.e. when there is no need to transmit high data rates.

NPC values are not actual requirements but informative only, and are calculated based on actual test data. Table B.1 gives some examples for NPC calculation.

Table B.1: NPC examples calculated according to P_{BBport} values in table B.2

	Data rate (Mbps)	Distance (km)	NPC (mW/Mbps)		
			Tier 1	Tier 2	Tier 3
ADSL2plus (19,8 dBm)	10	2,5	130	120	110
VDSL2 (profile 8b)	17	1,2	117,6	106	94
VDSL2 (profile 12a)	34	0,45	53	47	44
VDSL2 (profile 17a)	38	0,45	47,4	42	39,5
VDSL2 (profile 30a)	65	0,15	38,5	30,8	26,2
OLT (GPON)	2 488	Optical budget: Class B+	6,0	4,4	3,2
OLT (Point to Point up to 1 000 Mbps)	1 000	Optical budget class as in clause 5.3.1	5	4,5	4

Table B.2: $P_{\text{BBl ine}}$ values used in the example for calculation of NPC

Full power state	$P_{\text{BBl ine}}$ (W)		
	Tier 1	Tier 2	Tier 3
ADSL2plus (19,8 dBm)	1,3	1,2	1,1
VDSL2 (profile 8b)	2	1,8	1,6
VDSL2 (profile 12a, 17a)	1,8	1,6	1,5
VDSL2 (profile 30a)	2,5	2,0	1,7
OLT (GPON)	15	11	8
OLT (Point to Point up to 1 000 Mbps)	5	4,5	4

Annex C (informative): Measurement power consumption for DSLAM/MSAN and OLT equipment for different number of active ports

In most cases of network deployment, the broadband access network equipment will not be fully configured (e.g. some ports are not activated for fully equipped subrack). To verify the dynamic power management capability, it is necessary to measure the power consumption of network equipment under different configurations.

The power consumption should be measured with a power measurement instrument at Interface A according to clause 5.2 for a defined fully equipped DSLAM or MSAN with maximum configuration and to clause 5.3 for the OLT equipment. The ports are activated and carry traffic. The system can be powered either through a battery assembly or rectifier set at the nominal voltage as described in clause 5.1.1.

The power consumption measurements should be measured for the following percentages of activated ports:

- 40 % of the number of ports of a line termination boards of a DSLAM, MSAN or OLT;
- 80 % of the number of ports of a line termination boards of a DSLAM, MSAN or OLT;
- 100 % of the number of ports of a line termination boards of a DSLAM, MSAN or OLT.

History

Document history		
V1.2.1	October 2011	Publication as ES 203 215
V1.2.11	December 2014	EN Approval Procedure AP 20150404: 2014-12-05 to 2015-06-04