

Draft **ETSI EN 303 214** V1.1.1 (2010-07)

---

*European Standard (Telecommunications series)*

**Data Link Services (DLS) System;  
Community Specification for application under the  
Single European Sky Interoperability Regulation EC 552/2004  
requirements for ground constituents and system testing**

---



---

Reference

DEN/AERO-00003

---

Keywords

aeronautical, air traffic management

**ETSI**

650 Route des Lucioles  
F-06921 Sophia Antipolis Cedex - FRANCE

Tel.: +33 4 92 94 42 00 Fax: +33 4 93 65 47 16

Siret N° 348 623 562 00017 - NAF 742 C  
Association à but non lucratif enregistrée à la  
Sous-Préfecture de Grasse (06) N° 7803/88

---

**Important notice**

Individual copies of the present document can be downloaded from:

<http://www.etsi.org>

The present document may be made available in more than one electronic version or in print. In any case of existing or perceived difference in contents between such versions, the reference version is the Portable Document Format (PDF). In case of dispute, the reference shall be the printing on ETSI printers of the PDF version kept on a specific network drive within ETSI Secretariat.

Users of the present document should be aware that the document may be subject to revision or change of status. Information on the current status of this and other ETSI documents is available at

<http://portal.etsi.org/tb/status/status.asp>

If you find errors in the present document, please send your comment to one of the following services:

[http://portal.etsi.org/chaicor/ETSI\\_support.asp](http://portal.etsi.org/chaicor/ETSI_support.asp)

---

**Copyright Notification**

No part may be reproduced except as authorized by written permission.  
The copyright and the foregoing restriction extend to reproduction in all media.

© European Telecommunications Standards Institute 2010.  
All rights reserved.

**DECT™**, **PLUGTESTS™**, **UMTS™**, **TIPHON™**, the TIPHON logo and the ETSI logo are Trade Marks of ETSI registered for the benefit of its Members.

**3GPP™** is a Trade Mark of ETSI registered for the benefit of its Members and of the 3GPP Organizational Partners.

**LTE™** is a Trade Mark of ETSI currently being registered

for the benefit of its Members and of the 3GPP Organizational Partners.

**GSM®** and the GSM logo are Trade Marks registered and owned by the GSM Association.

# Contents

Intellectual Property Rights .....	7
Foreword.....	7
Introduction .....	7
1 Scope .....	8
2 References .....	8
2.1 Normative references .....	8
2.2 Informative references.....	9
3 Definitions and abbreviations.....	10
3.1 Definitions .....	10
3.2 Abbreviations .....	10
4 Requirements for implementing Data Link Services .....	12
4.0 Precedence.....	12
4.1 Constituents of a DLS System.....	12
4.1.1 Unconditional Constituent - Ground Ground ATN Routers .....	13
4.1.1.1 Eurocontrol DLS Specification, clause B.2.1.1.....	13
4.1.1.2 Eurocontrol DLS Specification, clause B.2.1.2.....	13
4.1.1.3 Eurocontrol DLS Specification, clause B.2.1.3.....	13
4.1.1.4 Eurocontrol DLS Specification, clause B.2.5.1.....	13
4.1.1.5 Eurocontrol DLS Specification, clause B.2.5.5.....	14
4.1.1.6 Eurocontrol DLS Specification, clause B.2.5.7.....	14
4.1.2 Unconditional Constituent - ATM Data Processing .....	14
4.1.2.1 Eurocontrol DLS Specification, clause A.2.1.7 .....	14
4.1.2.2 Eurocontrol DLS Specification, clause A.2.1.8 .....	14
4.1.2.3 Eurocontrol DLS Specification, clause A.2.1.9 .....	15
4.1.2.4 Void.....	15
4.1.2.5 ACM Uplink Message Elements .....	15
4.1.2.6 ACM Downlink Message Elements .....	15
4.1.2.7 Eurocontrol DLS Specification, clause A.2.3.1 .....	15
4.1.2.8 ACL Uplink Message Elements .....	15
4.1.2.9 ACL Downlink Message Elements .....	15
4.1.2.10 AMC Uplink Message Elements.....	15
4.1.2.11 Eurocontrol DLS Specification, clause B.2.1.3.....	15
4.1.2.12 Eurocontrol DLS Specification, clause B.2.4.8.....	15
4.1.2.13 Eurocontrol DLS Specification, clause B.2.1.2.....	16
4.1.2.14 Eurocontrol DLS Specification, clause B.2.2.1.....	16
4.1.2.15 Eurocontrol DLS Specification, clause B.2.2.2.....	16
4.1.2.16 Eurocontrol DLS Specification, clause B.2.2.4.....	16
4.1.2.17 Eurocontrol DLS Specification, clause B.2.2.5.....	16
4.1.2.18 Eurocontrol DLS Specification, clause B.2.3.1.....	16
4.1.2.19 Eurocontrol DLS Specification, clause B.2.3.2.....	16
4.1.2.20 Eurocontrol DLS Specification, clause B.2.4.1.....	17
4.1.2.21 Eurocontrol DLS Specification, clause B.2.4.2.....	17
4.1.2.22 Eurocontrol DLS Specification, clause B.2.4.3.....	17
4.1.2.23 Eurocontrol DLS Specification, clause B.2.4.5.....	17
4.1.2.24 Eurocontrol DLS Specification, clause B.2.4.6.....	17
4.1.2.25 Eurocontrol DLS Specification, clause B.2.5.1.....	18
4.1.2.26 Eurocontrol DLS Specification, clause B.2.5.2.....	18
4.1.2.27 Eurocontrol DLS Specification, clause B.2.5.5.....	18
4.1.2.28 Void.....	18
4.1.2.29 Void.....	18
4.1.2.30 Void.....	18
4.1.2.31 Ground network interconnection.....	18
4.1.2.32 Void.....	18

4.1.2.33	Eurocontrol DLS Specification, clause C.2.3.6.....	19
4.1.3	Unconditional Constituent - Ground Data Recording equipment.....	19
4.1.4	Unconditional Constituent - Ground Display (HMI).....	19
4.1.4.1	Eurocontrol DLS Specification, clause A.2.1.5 .....	19
4.1.4.2	Eurocontrol DLS Specification, clause A.2.1.6 .....	19
4.1.5	Conditional Constituent - Air Ground ATN Routers.....	19
4.1.5.1	Eurocontrol DLS Specification, clause B.2.1.2.....	19
4.1.5.2	Eurocontrol DLS Specification, clause B.2.1.3.....	19
4.1.5.3	Eurocontrol DLS Specification, clause B.2.5.1.....	19
4.1.5.4	Eurocontrol DLS Specification, clause B.2.5.4.....	19
4.1.5.5	Eurocontrol DLS Specification, clause B.2.5.5.....	20
4.1.5.6	Eurocontrol DLS Specification, clause B.2.5.7.....	20
4.1.6	Conditional Constituent - VDL Mode 2 ground communications equipment .....	20
4.1.6.1	General Requirements.....	20
4.1.6.1.1	Eurocontrol DLS Specification, clause D.2.1.1 .....	20
4.1.6.2	Interoperability Requirements.....	21
4.1.6.2.1	Eurocontrol DLS Specification, clause D.2.1.3.....	21
4.1.6.2.2	Eurocontrol DLS Specification, clause D.2.1.4.....	21
4.1.6.2.3	Eurocontrol DLS Specification, clause D.2.1.5.....	21
4.1.6.3	VDL Mode2 Upper Layer .....	21
4.1.6.4	VDL Mode 2 Physical Layer and MAC Sublayer.....	21
4.2	Design Requirements for DLS ground constituents .....	21
4.2.1	Performance Requirements .....	21
4.2.2	Safety Requirements .....	21
4.2.3	Data Link Services.....	21
4.2.3.1	DLIC .....	22
4.2.3.1.1	Specific Interoperability Requirements .....	22
4.2.3.1.2	Specific Performance Requirements.....	23
4.2.3.1.3	Specific Safety Requirements.....	23
4.2.3.2	ACM .....	23
4.2.3.2.1	Specific Interoperability Requirements .....	23
4.2.3.2.2	ACM Uplink Message Elements .....	24
4.2.3.2.3	ACM Downlink Message Elements .....	25
4.2.3.2.4	Specific Performance Requirements.....	25
4.2.3.2.5	Specific Safety Requirements.....	25
4.2.3.3	ACL.....	25
4.2.3.3.1	Specific Interoperability Requirements .....	26
4.2.3.3.2	ACL Uplink Message Elements .....	26
4.2.3.3.3	ACL Downlink Message Elements .....	28
4.2.3.3.4	Void.....	29
4.2.3.3.5	Void.....	29
4.2.3.3.6	Specific Performance Requirements.....	30
4.2.3.3.7	Specific Safety Requirements.....	30
4.2.3.4	AMC .....	30
4.2.3.4.1	Specific Interoperability Requirements .....	30
4.2.3.4.2	AMC Uplink Message Elements .....	30
4.2.3.4.3	Eurocontrol DLS Specification, clause A.2.4.5.....	31
4.2.3.4.4	Specific Performance Requirements.....	31
4.2.3.4.5	Specific Safety Requirements.....	31
4.3	Associated Procedures.....	31
4.3.1	Eurocontrol DLS Specification, clause C.2.2.1 .....	31
4.3.2	Void .....	32
4.3.3	Eurocontrol DLS Specification, clause C.2.2.4 .....	32
4.3.4	Eurocontrol DLS Specification, clause C.2.2.6 .....	32
4.3.5	Eurocontrol DLS Specification, clause C.2.3.3 .....	32
4.3.6	Eurocontrol DLS Specification, clause C.2.6.3 .....	32
4.3.7	Eurocontrol DLS Specification, clause C.2.6.4 .....	32
4.3.8	Eurocontrol DLS Specification, clause C.2.6.5 .....	32
5	System Testing.....	32
5.1	Void.....	34
5.2	Void.....	34

5.3	Test configuration with simulator .....	34
5.3.1	Test for CM Application.....	34
5.3.2	Test for CPDLC Application .....	36
5.3.2.1	Test for CPDLC Connection Handling .....	36
5.3.2.2	CPDLC Timers .....	46
5.3.3	ACL Service .....	48
5.3.4	AMC Service .....	52
5.3.5	ACM Service .....	53
5.4	Test with real aircraft .....	60
6	Conformity Assessment materials.....	62
6.1	Eurocontrol DLS Specification, clause A.3.1.1.....	62
6.2	Eurocontrol DLS Specification, clauses B.3.2 and B.3.3 .....	63
6.3	Eurocontrol DLS Specification, clause B.3.4.....	63
6.4	Eurocontrol DLS Specification, clause C.3.....	64
6.5	Eurocontrol Specification, clause D.3.2 .....	64
<b>Annex SA (normative): Standards Annex.....</b>		<b>65</b>
SA.1	Correspondence between this European Standard and the Single European Sky Interoperability Regulation (as amended) for the ground implementation of data link services, derived from the ICAO standard Context Management (CM) and Controller Pilot Data Link Communication (CPDLC) applications .....	65
<b>Annex SB (normative): Standards Annex.....</b>		<b>89</b>
SB.1	Correspondence between this European Standard and Commission Regulation laying down requirements on data link services for the single European sky (as corrected) [i.2] for the ground implementation of data link services, derived from the ICAO standard Context Management (CM) and Controller Pilot Data Link Communication (CPDLC) applications.....	90
<b>Annex A (normative): Checklist .....</b>		<b>100</b>
A.1	Interoperability Regulation Annex II Essential Requirements; Part A: General requirements.....	100
A.2	Interoperability Regulation Annex II Essential Requirements; Part B: Specific requirements.....	104
A.2.1	Systems and procedures for airspace management.....	104
A.2.2	Systems and procedures for air traffic flow management .....	104
A.2.3	Systems and procedures for air traffic services .....	105
A.2.3.1	Flight data processing systems.....	105
A.2.3.2	Surveillance data processing systems .....	106
A.2.3.3	Human-machine interface systems .....	106
A.2.4	Communications systems and procedures for ground-to-ground, air-to-ground and air-to-air communications .....	107
A.2.5	Navigation systems and procedures .....	107
A.2.6	Surveillance systems and procedures .....	108
A.2.7	Systems and procedures for aeronautical information services.....	108
A.2.8	Systems and procedures for the use of meteorological information.....	108
<b>Annex B (normative): Requirements on Datalink-Service.....</b>		<b>110</b>
B.1	Articles of the Datalink-Service Regulation (EC 29/2009).....	111
B.1.1	Article 1 Subject matter and scope .....	111
B.1.2	Article 2 Definitions.....	112
B.1.3	Article 3 Datalink services .....	113
B.1.4	Article 4 Associated procedures .....	115
B.1.5	Article 5 Obligations of ATS providers for data link communications.....	116
B.1.6	Article 6 Obligations of operators for data link communications.....	118
B.1.7	Article 7 General obligations of Member States for data link communications.....	119
B.1.8	Article 8 Data link communication for transport type State aircraft .....	120
B.1.9	Article 9 Obligations of air navigation services providers and other entities for data link communications .....	121
B.1.10	Article 10 Safety requirements .....	121
B.1.11	Article 11 Conformity or suitability for use of constituents.....	122

B.1.12	Article 12 Verification of systems.....	123
B.1.13	Article 13 Additional requirements .....	124
B.1.14	Article 14 Exemptions.....	126
B.1.15	Article 15 Entry into force and application .....	127
B.2	Annexes of the IR.....	128
B.2.1	Annex I, Airspace referred to in Article 1(3) .....	128
B.2.2	Annex II, Definition of data link services referred to in Articles 3, 4, 5 and 7 and Annex IV .....	130
B.2.3	Annex III, ICAO provisions referred to in Articles 3, 5, 6, 7, 8, 9 and 13 and Annex IV / Eurocae documents referred to in Articles 3 and 13 and Annex II.....	134
B.2.4	Annex IV, Requirements referred to in Articles 5, 6, 7, 8 and 9.....	137
B.2.4.1	Part A: Requirements for end-to-end communications.....	137
B.2.4.2	Part B: Requirements for air-ground communications based on ATN and VDL Mode 2 .....	138
B.2.4.3	Part C: Requirements for air-ground communications based on other communication protocols.....	140
B.2.4.4	Part D: Conditions referred to in Part C.....	141
B.2.5	Annex V, Requirements for the assessment referred to in Article 11 of the conformity or suitability for use of constituents .....	142
B.2.6	Annex VI, Conditions referred to in Article 12.....	144
B.2.7	Annex VII.....	146
B.2.7.1	Part A: Requirements for the verification of systems referred to in Article 12(1).....	146
B.2.7.2	Part B: Requirements for the verification of systems referred to in Article 12(2).....	148
<b>Annex C (normative):</b>	<b>Traceability of tests on Data Link Services .....</b>	<b>150</b>
<b>Annex D (informative):</b>	<b>The EN title in the official languages .....</b>	<b>157</b>
<b>Annex E (informative):</b>	<b>Bibliography.....</b>	<b>158</b>
History .....		159

---

## Intellectual Property Rights

IPRs essential or potentially essential to the present document may have been declared to ETSI. The information pertaining to these essential IPRs, if any, is publicly available for **ETSI members and non-members**, and can be found in ETSI SR 000 314: "*Intellectual Property Rights (IPRs); Essential, or potentially Essential, IPRs notified to ETSI in respect of ETSI standards*", which is available from the ETSI Secretariat. Latest updates are available on the ETSI Web server (<http://webapp.etsi.org/IPR/home.asp>).

Pursuant to the ETSI IPR Policy, no investigation, including IPR searches, has been carried out by ETSI. No guarantee can be given as to the existence of other IPRs not referenced in ETSI SR 000 314 (or the updates on the ETSI Web server) which are, or may be, or may become, essential to the present document.

---

## Foreword

This European Standard (Telecommunications series) has been produced by ETSI Technical Committee Aeronautics (AERO), and is now submitted for the Public Enquiry phase of the ETSI standards Two-step Approval Procedure.

The present document has been produced by ETSI in response to European Commission mandate M/438 for the Interoperability of the European Air Traffic Management Network.

The present document has been developed in cooperation with Eurocae for compliance with the Essential Requirements of the Single European Sky Interoperability Regulation [i.2] and/or requirements given in implementing rules for interoperability based on the Single European Sky Interoperability Regulation.

The presumption of conformity which is linked to the full application of the present document can only be claimed after it has been listed in the Official Journal of the European Union as Community Specification.

General and specific requirements for presumption of conformity to SES Interoperability Regulation 552/2004 [i.6] are given in the normative annexes of the present document.

NOTE: Other requirements and other EU Regulations and/or Directives may be applicable to the product(s) falling within the scope of the present document.

<b>Proposed national transposition dates</b>	
Date of latest announcement of this EN (doa):	3 months after ETSI publication
Date of latest publication of new National Standard or endorsement of this EN (dop/e):	6 months after doa
Date of withdrawal of any conflicting National Standard (dow):	6 months after doa

---

## Introduction

The European Union launched the Legislation "Single European Sky" (SES) in 2002 which was adopted in 2004 and amended in 2009 [i.6].

The SES legislation is based on a framework of 4 regulations, which includes the Interoperability Regulation [i.6]. The objective of the Interoperability Regulation is to ensure interoperability of the European Air Traffic Management Network (EATMN) consistent with air navigation services. Under this regulation, the use of a European Standard referenced in the Official Journal of the European Union as Community Specification (CS) is a means of compliance to the essential requirements of the Regulation and/or the relevant implementing rules for interoperability.

The present document takes into account the Council Decision 2009/320/EC [i.8] endorsing the European Air Traffic Management Master Plan for the Single European Sky ATM Research (SESAR) project.

---

# 1 Scope

The present document is applicable to the ground implementation of data link services, derived from the ICAO standard Context Management (CM) and Controller Pilot Data Link Communication (CPDLC) applications, including test procedures.

Any software elements related to the software assurance level of data link ground implementation are outside of the scope of the present document. As such the essential requirements of the Interoperability Regulation are not considered for software elements within the present document.

The present document does not give presumption of conformity to any of the requirements stemming from the Regulation (EC) 216/2009 [i.9] as amended by Regulation (EC) 1108/2009 [i.10].

The present document does not give presumption of conformity related to the maintenance requirements, environmental constraints, effect of harmful interference and civil/military coordination.

NOTE: For these ERs, please refer to the Air Navigation Service Provider procedures.

Requirements in the present document which refer to "should" statements or recommendations in the normatively referenced material (clause 2.1) are to be interpreted as fully normative ("shall") for the purpose of compliance with the present document.

---

# 2 References

References are either specific (identified by date of publication and/or edition number or version number) or non-specific. For specific references, only the cited version applies. For non-specific references, the latest version of the reference document (including any amendments) applies.

Referenced documents which are not found to be publicly available in the expected location might be found at <http://docbox.etsi.org/Reference>.

NOTE: While any hyperlinks included in this clause were valid at the time of publication ETSI cannot guarantee their long term validity.

## 2.1 Normative references

The following referenced documents are necessary for the application of the present document.

- [1] ICAO Convention on International Civil Aviation, Annex 10 - Aeronautical Telecommunications, Volume II: "Communication Procedures including those with PANS status", Sixth edition - October 2001, incorporating Amendments 70-84, Amendment 84 (applicable 19/11/2009).
- [2] ICAO Convention on International Civil Aviation, Annex 10 - Aeronautical Telecommunications, Volume III: "Communication Systems, Part I - Digital Data Communication Systems", Second Edition - July 2007, incorporating Amendments 70-84, Amendment 84 (applicable 19/11/2009), Chapter 6 - VHF Air-ground Digital Link (VDL).
- [3] ICAO Doc. 4444-ATM/501: "Procedures for Air Navigation Services - Air Traffic Management", Fifteenth Edition - 2007, incorporating Amendments 1 - 5. ISBN 978-92-92310-11-0.
- [4] ICAO Doc. 9705-AN/956: "Manual of Technical Provisions for the Aeronautical Telecommunications Network (ATN)", Second Edition, December 1999, including identified PDRs.
- [5] ICAO Doc. 9776/AN970: "Manual on VHF Digital Link (VDL) Mode 2", First Edition, 2001.
- [6] EUROCAE Document ED-110B / RTCA DO-280B: "Interoperability Requirements Standard for Aeronautical Telecommunication Network Baseline 1" (ATN B1 INTEROP STANDARD) December 2007.



- [7] EUROCAE Document ED-120 / RTCA DO-290: "Safety and Performance Requirements Standard for Initial Air Traffic DLS in Continental Airspace" (SPR IC), May 2004, including Change 1 (April 2007) and Change 2 (October 2007).
- [8] EUROCAE Document ED-111: "Functional Specifications for CNS/ATM Ground Recording", July 2002 including Amendment 1 (30/07/2003).
- [9] EUROCONTROL-SPEC-0106: "EUROCONTROL Specification For On-Line Data Interchange (OLDI)", Edition 4.1, 16 January 2008 (Recognised as SES Community specification, OJ C 149, 14.6.2008, p.22).
- [10] ARINC Specification 631-5: "VHF Digital Link (VDL) Mode 2 Implementation Provisions" (Published 3 December 2008).
- [11] ICAO EUR Doc 011: "EUR Frequency Management Manual for Aeronautical Mobile and Aeronautical Radio Navigation Services" ICAO European and North Atlantic Office, Edition 2009.

NOTE: Available at [http://www.paris.icao.int/documents\\_open/files.php?subcategory\\_id=96](http://www.paris.icao.int/documents_open/files.php?subcategory_id=96).

- [12] ETSI EN 301 841-1 (V1.3.1): "VHF air-ground Digital Link (VDL) Mode 2; Technical characteristics and methods of measurement for ground -based equipment; Part 1: Physical layer and MAC sub-layer".
- [13] ETSI EN 301 841-2 (V1.1.1): "Electromagnetic compatibility and Radio spectrum Matters (ERM); VHF air-ground Digital Link (VDL) Mode 2; Technical characteristics and methods of measurement for ground -based equipment; Part 2: Upper layers".
- [14] Commission Regulation (EC) No 1702/2003 of 24 September 2003 laying down implementing rules for the airworthiness and environmental certification of aircraft and related products, parts and appliances, as well as for the certification of design and production organisations, OJ L 243, 27.09.2003, p.6-79.

## 2.2 Informative references

The following referenced documents are not necessary for the application of the present document but they assist the user with regard to a particular subject area.

- [i.1] ICAO Convention on International Civil Aviation, Annex 1 - Personnel Licensing, 10th edition, incorporating Amendments 1-167, July 2006. ISBN 92-9194-750-4.
- [i.2] Commission Regulation (EC) No. 29/2009, of 16 January 2009, laying down requirements on data link services for the single European sky, OJ L 13/3 (17.1.2009), including Corrigendum published in the EU Official Journal L104 at 24.04.2009.
- [i.3] Commission Regulation (EC) No 30/2009 of 16 January 2009 amending Regulation (EC) No 1032/2006 as far as the requirements for automatic systems for the exchange of flight data supporting data link services are concerned, OJ L 13/20 (17.1.2009).
- [i.4] ICAO Draft Doc. 9880-AN/466 Manual on Detailed Technical Specifications for the Aeronautical Telecommunication Network (ATN) using ISO/OSI standards and protocols, Part I - Air-Ground Applications, 1st edition (draft v1.1), November 2006.
- [i.5] Regulation (EC) No 549/2004 of the European Parliament and of the Council of 10 March 2004 laying down the framework for creation of the single European sky (the framework Regulation), OJ L 96, 31.03.2004, p. 1 as amended by Regulation (EC) No 1070/2009, OJ L 300, 14.11.2009, p. 34.
- [i.6] Regulation (EC) No 552/2004 of the European Parliament and of the Council of 10 March 2004 on the interoperability of the European Air Traffic Management network (interoperability Regulation), OJ L 96, 31.03.2004, p. 26 as amended by Regulation (EC) No 1070/2009, OJ L 300, 14.11.2009, p. 34.
- [i.7] ARINC Characteristic 750-4, VHF Data Radio (2004).

- [i.8] Council Decision 2009/320/EC of 30 March 2009 endorsing the European Air Traffic Management Master Plan of the Single European Sky ATM Research (SESAR) project.
- [i.9] Regulation (EC) No 216/2008 of the European Parliament and of the Council of 20 February 2008 on common rules in the field of civil aviation and establishing a European Aviation Safety Agency, and repealing Council Directive 91/670/EEC, Regulation (EC) No 1592/2002 and Directive 2004/36/EC, OJ L 79, 19.03.2008, p. 1-49.
- [i.10] Regulation (EC) No 1108/2009 of the European Parliament and of the Council of 21 October 2009 amending Regulation (EC) No 216/2008 in the field of aerodromes, air traffic management and air navigation services and repealing Directive 2006/23/EC, OJ L 309, 24.11.2009, p. 51-70.
- [i.11] EUROCONTROL Specification on Data Link Services, Eurocontrol -Spec-0116, Edition 2.1 (Edition date 28 January 2009).

---

## 3 Definitions and abbreviations

### 3.1 Definitions

For the purposes of the present document, the terms and definitions given in the Framework Regulation [i.5], Interoperability Regulation [i.6] and the Implementing Rule [i.2] apply.

### 3.2 Abbreviations

For the purposes of the present document, the following abbreviations apply:

ACL	ATC Clearances service
ACM	ATC Communications Management service
ADEP	Departure Aerodrome
ADES	Destination Aerodrome
AE	Application Entities
AIP	Aeronautical Information Publication
AMC	ATC Microphone Check service
ANSP	Air Navigation Service Provider
ARS	Administrative Region Selector field (of NSAP address)
ATC	Air Traffic Control
ATM	Air Traffic Management
ATN	Aeronautical Telecommunication Network
ATS	Air Traffic Services
ATSC	Air Traffic Services Communication
ATSP	Air Traffic Service Provider
C	Conditional
CDA	Current Data Authority
CLNP	Connectionless Network Protocol
CLTP	Connectionless Transport Protocol
CM	Context Management
CNS	Communications, Navigation, Surveillance
CP	Presentation Connect PPDU
CPA	Presentation Connect Accept PPDU
CPDLC	Controller Pilot Data Link Communication
CPR	Presentation Connect Reject PPDU
CS	Community Specification
CSP	Communication Service Provider
DLIC	Data Link Initiation Capability service
DLS	Data Link Service(s)
DM	Downlink Message
EASA	European Aviation Safety Agency
EATMN	European Air Traffic Management Network
EC	European Commission

ED	EUROCAE Document
ER	Essential Requirement
ES	End System
EUROCAE	European Organisation for Civil Aviation Equipment
HMI	Human-Machine Interface
ICAO	International Civil Aviation Organisation
ICS	ATN Internet Communications Service
IDRP	Inter-Domain Routing Protocol
IEC	International Electrotechnical Commission
IFPS	Initial Flight Plan Processing System
IP	Internet Protocol
ISO	International Organisation for Standardisation
ITU-T	International Telecommunication Union - Standardization Sector
LACK	Logical Acknowledgement
LOC	Location field (of NSAP address)
LOF	Log On Forwarding (OLDI Message)
N	No Response
NAN	Next Authority Notified (OLDI Message)
NDA	Next Data Authority
NPDU	Network Protocol Data Unit
NSAP	Network Service Access Point
NSEL	Network Selector
OICS	Operational Implementation Conformance Statement
OLDI	On-Line Data Interchange
OSI	Open Systems Interconnection
PANS	Procedures for Air Navigation Services
PDR	Proposed Defect Report (to ICAO Doc. 9705)
PER	Packed Encoding Rules (of Abstract Syntax Notation One)
PICS	Protocol Implementation Conformance Statement
PPDU	Presentation Protocol Data Unit
R-ATSU	Receiving Air Traffic Services Unit
RTCA	Radio Technical Commission for Aeronautics, Inc.
SAC	Short Accept SPDU
SACC	Short Accept Continue SPDU
SARPs	ICAO Standards and Recommended Practices
SCN	Short Connect SPDU
SES	Single European Sky
SNDCF	Sub-Network Dependent Convergence Function
SO	Safety Objective
SPDU	Session Protocol Data Unit
SPR	Safety and Performance Requirements
SQP	Signal Quality Parameter
SR	Safety Requirement
SRF	Short Refuse SPDU
SRFC	Short Refuse Continue SPDU
SYS	System Identifier field (of NSAP address)
T-ATSU	Transferring Air Traffic Services Unit
TC	Transport Connection
TP4	Transport Protocol Class 4
TSEL	Transport Selector
U	Unconditional
ULCS	ATN Upper Layer Communications Service
UM	Uplink Message
VDL	Very High Frequency Digital Link
VHF	Very High Frequency
WAN	Wide Area Network
X.25	ITU-T Packet Switching standard
XID	Exchange Identifier

## 4 Requirements for implementing Data Link Services

### 4.0 Precedence

In the event of a conflict between the interoperability requirements expressed in ED-110B [6] and the requirements in the present document, the latter shall take precedence.

NOTE: This requirement is equivalent to Eurocontrol DLS Specification [i.11], clause A.2.1.10.

### 4.1 Constituents of a DLS System

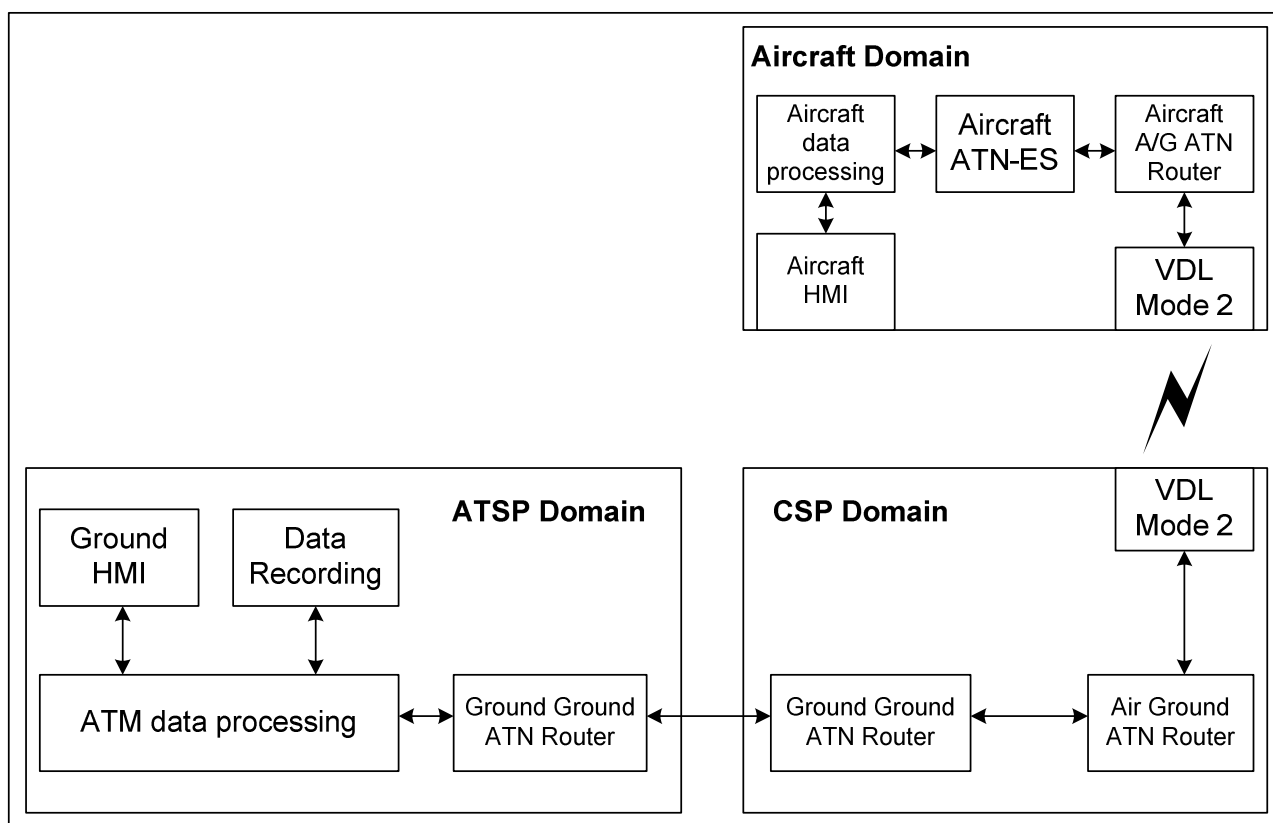

**Figure 1: ATN Data Link System Architecture**

The DLS System as depicted in figure 1 consists of the constituents relevant for end-to-end data link communications within the following domains:

- Aircraft domain.
- CSP domain.
- ATSP domain.

The present document provides a CS for the Air Traffic Service Provider (ATSP) and Air/Ground Communications Service Provider (CSP) domain only. Description of airborne domain will be published by EASA.

An ATSP has to at least implement the following constituents:

- Ground Ground ATN Router.
- ATM Data Processing.
- Ground HMI.

- Data Recording.

Therefore these constituents are called "unconditional constituents" within the present document.

A CSP has to implement at least the following constituents:

- Ground Ground ATN Router.
- Air Ground Router.
- VDL Mode 2.

For an ATSP it is not required to implement the constituents Air Ground Router and VDL Mode 2 when interconnected to an external CSP. Therefore these constituents are called "conditional constituents" within the present document.

In a ground installation it is possible to merge the ATSP and CSP domains. In such a case one Ground Ground Router might be sufficient.

In a real implementation one can combine the functionalities of several constituents such as Ground Ground Router and Air Ground Router, or Data Recording and ATM Data Processing as appropriate.

#### 4.1.1 Unconditional Constituent - Ground Ground ATN Routers

NOTE: The Ground Ground Router can be part of the Air Ground Router.

##### 4.1.1.1 Eurocontrol DLS Specification, clause B.2.1.1

CSPs and ATSPs shall operate Ground-Ground ATN Routers, as defined by ICAO Doc 9705 [4], in order to support interoperations with each other.

NOTE: ATN Ground-Ground Routers will have local interfaces to ground networks, such as X.25 and Ethernet. These interfaces are outside of the scope of the specifications outlined in the present document.

##### 4.1.1.2 Eurocontrol DLS Specification, clause B.2.1.2

ATN Routers shall comply with the requirements of ED-110B [6], chapters 2 and 3 that are applicable to ATN communications services (ICS and ULCS), CM Application and CPDLC Applications, and amended as described in the present document.

##### 4.1.1.3 Eurocontrol DLS Specification, clause B.2.1.3

In addition to the Doc 9705 [4] updates specified in ED-110B [6], chapter 2.4, implementations shall additionally incorporate all defect resolutions listed in table 1.

**Table 1: Modifications to ICAO Doc 9705 [4] - General**

PDR ref	PDR Description (Ed 2)	Requirements Conditionality	
		C/U	Condition
99070001	ICAO 9705 [4] Edition 2 - Editorial Errors	C	It is up to the implementation to use it or not.
M1050001	Correction of CLNP Priority	C	It is up to the implementation to use it or not. Documents restriction of CLNP priorities on VHF data links.
M0060001	ICAO 9705 [4] Edition 2 - Editorial Errors	C	It is up to the implementation to use it or not.
NOTE: "U" stands for "unconditional" means that it has to be supported. "C" stands for "conditional" means that it has to be supported under certain conditions as outlined in table 1.			

##### 4.1.1.4 Eurocontrol DLS Specification, clause B.2.5.1

ICS implementations shall conform to the requirements of ED-110B [6] (which refers to ICAO Doc. 9705 [4], Sub-Volume V), except where indicated otherwise in the present document.

#### 4.1.1.5 Eurocontrol DLS Specification, clause B.2.5.5

In addition to the Doc 9705 updates specified in ED-110B [6], chapter 2.4, ICS implementations shall incorporate the defect resolutions listed in table 2.

**Table 2: Modifications to ICAO Doc 9705 [4] - ICS**

PDR ref	PDR Description (Ed 2)	Requirements Conditionality	
		C/U	Condition
99090001	ICS: Over-specification of ARS Address	C	It is up to the implementation to use it or not. Needed for ARINC network compatibility.
99100004	ICS: ISO/IEC 8208 Non-Standard Default Packet Size Facility	C	It is up to the implementation to use it or not. Relaxation of requirement. No interoperability implications.
99100005	ICS: Reservation of Unassigned/Undefined Values	C	It is up to the implementation to use it or not. Only impact of this PDR could be on implementations that used private values.
M0040001	ICS: Incorrect/Duplicated ATSC Class Security Tag	C	It is up to the implementation to use it or not.
M0040002	Potential Misdelivery of CLNP Packets (32 bit checksum)	C	It is up to the implementation to use it or not. Support of 32 bit checksum, which is mandatory according ED-110B [6], chapter 2.4, is not required.
M4050001	ICS: Typos and inconsistencies in the Doc. 9705 [4] Sub-Volume V	U	
M5020001	ICS: Inclusion of ATN IP SNDCF	C	It is up to the implementation to use it or not.
NOTE: "U" stands for "unconditional" means that it has to be supported. "C" stands for "conditional" means that it has to be supported under certain conditions as outlined in table 2.			

#### 4.1.1.6 Eurocontrol DLS Specification, clause B.2.5.7

The IDRPs parameter setting listed in table 3 shall be implemented by all Ground Ground ATN Routers.

**Table 3: IDRPs parameter settings**

Entity	Timer	Value	Requirements Conditionality	
			C/U	Condition
IDRP	IDRP Hold time	90 s	C	It is up to the implementation to use it or not.
NOTE: "U" stands for "unconditional" means that it has to be supported. "C" stands for "conditional" means that it has to be supported under certain conditions as outlined in table 3.				

### 4.1.2 Unconditional Constituent - ATM Data Processing

NOTE: The ATM Data Processing includes at least the ATN-End System and the Flight Data Processing capability.

#### 4.1.2.1 Eurocontrol DLS Specification, clause A.2.1.7

Downlink CPDLC messages not supported by the implementation shall result in an appropriate error response, as defined in ED-110B [6], being sent to the airborne system.

#### 4.1.2.2 Eurocontrol DLS Specification, clause A.2.1.8

ATM Data Processing constituents shall be able to generate and send all uplink message (UM) elements that are implemented in support of the ACL, ACM and AMC services.

NOTE: Unconditional and Conditional uplink message elements are specified by reference to tables 11, 13 and 15 of the present document.

#### 4.1.2.3 Eurocontrol DLS Specification, clause A.2.1.9

Latitude and longitude included in CPDLC message elements shall use the (degrees, minutes, seconds) format.

NOTE: This requirement is intended to optimize the avionics systems processing efficiency.

#### 4.1.2.4 Void

#### 4.1.2.5 ACM Uplink Message Elements

The ATM Data Processing constituent shall comply with the requirements as defined in clause 4.2.3.2.2 of the present document.

#### 4.1.2.6 ACM Downlink Message Elements

The ATM Data Processing constituent shall comply with the requirements as defined in clause 4.2.3.2.3 of the present document.

#### 4.1.2.7 Eurocontrol DLS Specification, clause A.2.3.1

Implementations of the ACL service shall comply with the air-ground interoperability requirements specified in ED-110B [6], chapters 4.2 and 4.4, except where indicated otherwise in the present document.

#### 4.1.2.8 ACL Uplink Message Elements

The ATM Data Processing constituent shall comply with the requirements as defined in clause 4.2.3.3.2 of the present document.

#### 4.1.2.9 ACL Downlink Message Elements

The ATM Data Processing constituent shall comply with the requirements as defined in clause 4.2.3.3.3 of the present document.

#### 4.1.2.10 AMC Uplink Message Elements

The ATM Data Processing constituent shall comply with the requirements as defined in clause 4.2.3.4.2 of the present document.

#### 4.1.2.11 Eurocontrol DLS Specification, clause B.2.1.3

In addition to the Doc 9705 [4] updates specified in ED-110B [6], chapter 2.4, implementations shall additionally incorporate all defect resolutions listed in table 1.

#### 4.1.2.12 Eurocontrol DLS Specification, clause B.2.4.8

In addition to the Doc 9705 [4] updates specified in ED-110B [6], chapter 2.4, ULCS implementations shall additionally incorporate all defect resolutions listed in table 4.

**Table 4: Modifications to ICAO Doc 9705 [4] - ULCS**

PDR ref	PDR description Ed. 2	Requirements Conditionality	
		U/C	Condition
M0040002	Potential Misdelivery of CLNP Packets (32 bit checksum)	C	It is up to the implementation to use it.  Support of 32 bit checksum, which is mandatory according ED-110B [6], chapter 2.4, is not required.
NOTE: "U" stands for "unconditional" means that it has to be supported. "C" stands for "conditional" means that it has to be supported under certain conditions as outlined in table 4.			

#### 4.1.2.13 Eurocontrol DLS Specification, clause B.2.1.2

Constituents incorporating an ATN End System shall comply with the requirements of ED-110B [6], chapters 2 and 3 that are applicable to ATN communications services (ICS and ULCS), CM Application and CPDLC Applications, and amended as described in the present document.

#### 4.1.2.14 Eurocontrol DLS Specification, clause B.2.2.1

Implementations of the CPDLC ground application entities shall comply with the interoperability requirements applicable to the CPDLC-start, CPDLC-message, CPDLC-end, CPDLC-user-abort and CPDLC-provider-abort services specified in ED-110B [6], chapter 3.3, except where indicated otherwise in the present document.

NOTE 1: The DSC-start, DSC-end and Forward services are out of scope of the present document.

NOTE 2: Only the "protected mode" CPDLC application (previously known as "PM-CPDLC") including the application message integrity check (application type 22) is required. The previously defined CPDLC without this feature (application type 2) is excluded.

NOTE 3: Where ED-110B [6] refers to CPDLC as specified in ICAO Doc. 9705 [4] (Sub-Volume II, chapter 2.3, modified by the specified defect resolutions), the provisions of ICAO Doc. 9880, Part I [i.4], chapter 3 may be taken as equivalent.  
This note is derived from Eurocontrol DLS Specification [i.11], clause B.2.2.6.

NOTE 4: The CPDLC provisions originally published in Doc 9705 [4] are entirely replaced by the resolution of defect report ref. M6050001. The CPDLC chapter of Doc 9880 [i.4] is technically aligned with this PDR resolution. A detailed mapping between these CPDLC provisions and Doc 9880 [i.4] is available for traceability purposes.  
This note is derived from Eurocontrol DLS Specification [i.11], clause B.2.2.6.

#### 4.1.2.15 Eurocontrol DLS Specification, clause B.2.2.2

The ATM Data Processing constituent shall be able to receive all downlink CPDLC message elements specified in ICAO Doc 9705 [4] and handle unsupported message element types as indicated in ED-110B [6], chapter 3.3.7.6.

#### 4.1.2.16 Eurocontrol DLS Specification, clause B.2.2.4

The ATM Data Processing constituent shall support and use the CPDLC application message integrity check mechanism, with the default checksum algorithm as specified in ED-110B [6], chapters 3.3.5.1 and 3.3.6.

#### 4.1.2.17 Eurocontrol DLS Specification, clause B.2.2.5

The ATM Data Processing constituent shall ensure that the 24-bit aircraft address included in the CPDLC integrity check computation is the value extracted from the corresponding flight plan, rather than the value received from the aircraft via DLIC or from an adjacent ATS Unit via inter-centre coordination message.

#### 4.1.2.18 Eurocontrol DLS Specification, clause B.2.3.1

Implementations of the CM ground application entities shall comply with the interoperability requirements applicable to the CM-logon, CM-contact, CM-update, CM-end, CM-user-abort and CM-provider-abort services specified in ED-110B [6], chapter 3.1, except where indicated otherwise in the present document.

#### 4.1.2.19 Eurocontrol DLS Specification, clause B.2.3.2

The CM-update service shall not be invoked by the ATM Data Processing constituent for aircraft in the applicable airspace.

NOTE 1: Minimal ground system support requirements for handling received CM-update primitives are given in ED-110B [6], Note after chapter 3.1.3.3.1.1.1.

NOTE 2: The CM-forward service is outside the scope of the present document.



#### 4.1.2.20 Eurocontrol DLS Specification, clause B.2.4.1

ULCS implementations shall conform to the requirements of ED-110B [6] (which refers to ICAO Doc. 9705 [4], Sub-Volume IV), except where indicated otherwise in the present document.

#### 4.1.2.21 Eurocontrol DLS Specification, clause B.2.4.2

Where Doc 9705 [4], section 4.4.3.2 specifies the base standard for the ATN session protocol, the phrase "together with all approved amendments and defect report resolutions" shall be taken to mean "including Technical Corrigendum 1 (2002)".

#### 4.1.2.22 Eurocontrol DLS Specification, clause B.2.4.3

Implementations of the ATN session protocol shall be capable of supporting the session protocol data units (SPDUs) listed in table 5, any other SPDUs being out of scope of the present document.

**Table 5: SPDU Support Requirements**

Value (Hex)	Abbreviation	Full SPDU Name
E8	SCN	Short Connect
F0	SAC	Short Accept
D8	SACC	Short Accept Continue
E0 - E3	SRF	Short Refuse E0: TC retained, transient refusal E1: TC retained, persistent refusal E2: TC released, transient refusal E3: TC released, persistent refusal
A0	SRFC	Short Refuse Continue
NOTE: The preferred value for implementation for encoding the SRF SPDU is "E3". (Derived from Eurocontrol DLS Specification [i.11], clause B.2.4.4.)		

#### 4.1.2.23 Eurocontrol DLS Specification, clause B.2.4.5

Where Doc 9705 [4], section 4.5.1.2 specifies the base standard for the ATN presentation protocol, the phrase "together with all approved amendments and defect report resolutions" shall be ignored.

#### 4.1.2.24 Eurocontrol DLS Specification, clause B.2.4.6

Implementations of the ATN presentation protocol shall be capable of supporting the presentation protocol data units (PPDUs) listed in table 6, any other PPDUs being out of scope of the present document.

**Table 6: PPDU Support Requirements**

Value (Hex)	Abbreviation	Full PPDU Name
02	SHORT-CP	Short Presentation Connect, unaligned PER
02	SHORT-CPA	Short Presentation Connect Accept, unaligned PER
x2	SHORT-CPR	Short Presentation Connect Reject, where x = reason code: 02: presentation-user 12: reason not specified (transient) 22: temporary congestion (transient) 32: local limit exceeded (transient) 42: called presentation address unknown (permanent) 52: protocol version not supported (permanent) 62: default context not supported (permanent) 72: user data not readable (permanent)
NOTE: The preferred value for encoding the SHORT-CPR PPDU is "02". (Derived from Eurocontrol DLS Specification [i.11], clause 2.4.7.)		

#### 4.1.2.25 Eurocontrol DLS Specification, clause B.2.5.1

ICS implementations shall conform to the requirements of ED-110B [6] (which refers to ICAO Doc. 9705 [4], Sub-Volume V), except where indicated otherwise in the present document.

#### 4.1.2.26 Eurocontrol DLS Specification, clause B.2.5.2

The ATM Data Processing constituent shall implement the TP4 protocol as specified in Doc 9705 [4], section 5.5.2.

NOTE: The connectionless transport protocol (CLTP) is outside the scope of the present document.

#### 4.1.2.27 Eurocontrol DLS Specification, clause B.2.5.5

In addition to ED-110B [6], chapter 2.4, ICS implementations shall incorporate the defect resolutions listed in table 7.

**Table 7: Modifications to ICAO Doc 9705 [4] - ICS**

PDR ref	PDR Description (Ed 2)	Requirements Conditionality	
		C/U	Condition
99090001	ICS: Over-specification of ARS Address	C	It is up to the implementation to use it or not. Needed for ARINC network compatibility.
99100005	ICS: Reservation of Unassigned/Undefined Values	C	It is up to the implementation to use it or not. Only impact of this PDR could be on implementations that used private values.
M0040002	Potential Misdelivery of CLNP Packets (32 bit checksum)	C	It is up to the implementation to use it. Support of 32 bit checksum, which is mandatory according ED-110B [6], chapter 2.4, is not required.
M4050001	ICS: Typos and inconsistencies in the Doc. 9705 [4], Sub-Volume V	C	It is up to the implementation to use it or not
NOTE:	"U" stands for "unconditional" means that it has to be supported. "C" stands for "conditional" means that it has to be supported under certain conditions as outlined in table 7.		

#### 4.1.2.28 Void

#### 4.1.2.29 Void

#### 4.1.2.30 Void

#### 4.1.2.31 Ground network interconnection

The interconnection of national and regional networks for the exchange of the "Logon Forward Message (LOF)" and the "Next Authority Notified Message (NAN)" shall be implemented in compliance with clauses 15.1 and 15.2 of the EUROCONTROL Specification for On-Line Data Interchange (OLDI) [9].

NOTE 1: This does not imply any obligation to implement OLDI between an ANSP's own systems.

NOTE 2: Ground-ground forwarding of the aircraft Logon information is the default mechanism used between data link equipped ground systems to exchange aircraft data link parameters. The DLIC Contact service is the fall-back (see section A.2.5.20 of EUROCONTROL DLS Specification [i.11] and clause 4.2.3.1.1.6 of the present document).

NOTE 3: This requirement is derived from Eurocontrol DLS Specification [i.11], clause C.2.3.4.

#### 4.1.2.32 Void

#### 4.1.2.33 Eurocontrol DLS Specification, clause C.2.3.6

On performing the flight plan association process, Ground Systems shall verify that the 24-bit aircraft address extracted from the flight plan matches the address received from the adjacent centre via the ground-ground forwarding function (LOF message).

NOTE: According to EUROCONTROL Specification for On-Line Data Interchange (OLDI) [9], clause 15.1, a LAM should only be sent if a matching flight plan has been found.

#### 4.1.3 Unconditional Constituent - Ground Data Recording equipment

Data link messages exchanged between an ATS Unit and aircraft, and between different ATS Units, shall be recorded according to the functional specifications for ground recording as published in EUROCAE Document ED-111 [8].

NOTE: This requirement is identical to Eurocontrol DLS Specification [i.11], clause C.2.5.1.

#### 4.1.4 Unconditional Constituent - Ground Display (HMI)

NOTE: The Ground Display could be part of a larger HMI, providing other ATS functions.

##### 4.1.4.1 Eurocontrol DLS Specification, clause A.2.1.5

Ground Display (HMI) constituents, shall provide a means to display data link messages and to elicit controller input (HMI).

##### 4.1.4.2 Eurocontrol DLS Specification, clause A.2.1.6

All CPDLC downlink message (DM) elements that are implemented in support of the ACL, ACM and AMC services shall be displayed to the controller in accordance with ED-110B [6].

#### 4.1.5 Conditional Constituent - Air Ground ATN Routers

##### 4.1.5.1 Eurocontrol DLS Specification, clause B.2.1.2

Air-ground ATN Routers shall comply with the requirements of ED-110B [6], chapters 2 and 3 that are applicable to ATN communications services (ICS and ULCS), CM Application and CPDLC Applications, and amended as described in the present document.

##### 4.1.5.2 Eurocontrol DLS Specification, clause B.2.1.3

In addition to PDRs outlined in ED-110B [6], chapter 2.4, implementations shall incorporate all defect resolutions listed in table 1 of the present document.

##### 4.1.5.3 Eurocontrol DLS Specification, clause B.2.5.1

ICS implementations shall conform to the requirements of ED-110B [6] except where indicated otherwise in the present document.

##### 4.1.5.4 Eurocontrol DLS Specification, clause B.2.5.4

ATN Air-Ground Routers supporting ATN communication services shall implement requirements for an ATN Router Class 5, as defined in ICAO Doc 9705 [4], section 5.2.4.1.

NOTE 1: Air-Ground Routers are not required to support the procedures for the optional non-use of IDRP.

NOTE 2: Support for sub-network dependent convergence functions (SNDCFs) other than the Mobile SNDCF is out of scope of the present document.

#### 4.1.5.5 Eurocontrol DLS Specification, clause B.2.5.5

In addition to PDRs outlined in ED-110B [6], chapter 2.4, ICS implementations shall incorporate the defect resolutions listed in table 8.

**Table 8: Modifications to ICAO Doc 9705 [4] - ICS**

PDR ref	PDR Description (Ed 2)	Requirements Conditionality	
		C/U	Condition
99090001	ICS: Over-specification of ARS Address	C	It is up to the implementation to use it or not. Needed for ARINC network compatibility.
99100003	ICS: LREF Compression and CLNP ECHO NPDUs	C	It is up to the implementation to use it or not. Used for compression of NSAP addresses.
99100004	ICS: ISO/IEC 8208 Non-Standard Default Packet Size Facility	C	It is up to the implementation to use it or not. Relaxation of requirement. No interoperability implications.
99100005	ICS: Reservation of Unassigned/Undefined Values	C	It is up to the implementation to use it or not. Only impact of this PDR could be on implementations that used private values.
M0040001	ICS: Incorrect/Duplicated ATSC Class Security Tag	C	It is up to the implementation to use it or not.
M4050001	ICS: Typos and inconsistencies in the Doc. 9705 Sub-Volume V	C	It is up to the implementation to use it or not.
M5020001	ICS: Inclusion of ATN IP SNDCF	C	It is up to the implementation to use it or not.
NOTE: "U" stands for "unconditional" means that it has to be supported. "C" stands for "conditional" means that it has to be supported under certain conditions as outlined in table 8.			

#### 4.1.5.6 Eurocontrol DLS Specification, clause B.2.5.7

The IDRPs parameter setting listed in table 9 shall be implemented by all Air-Ground ATN Routers.

**Table 9: IDRPs parameter settings**

Entity	Timer	Value	Requirements Conditionality	
			C/U	Condition
IDRP	IDRP Hold time	900 s	C	It is up to the implementation to use it or not.
NOTE: "U" stands for "unconditional" means that it has to be supported. "C" stands for "conditional" means that it has to be supported under certain conditions as outlined in table 9.				

### 4.1.6 Conditional Constituent - VDL Mode 2 ground communications equipment

#### 4.1.6.1 General Requirements

This clause specifies compliancy requirements for the VDL-Mode 2 air-ground data link service supporting the specified data link services and end-to-end communication services.

##### 4.1.6.1.1 Eurocontrol DLS Specification, clause D.2.1.1

Where ARINC 631 [10] identifies a specific deviation from ICAO VDL SARPs [2] and/or ICAO Manual on VDL Mode 2 [5] and/or EN 301 841-2 [13], the provisions of the former shall take precedence.

NOTE: ARINC 631 [10] also references ARINC 750 [i.7] for definition of Signal Quality Parameter (SQP) levels. Measurements of SQP levels may be passed over the air-ground link as parameters in the XID exchanges.

## 4.1.6.2 Interoperability Requirements

### 4.1.6.2.1 Eurocontrol DLS Specification, clause D.2.1.3

The VDL Mode 2 service shall be implemented in accordance with ARINC Specification 631 [10], except where indicated otherwise in the present document.

### 4.1.6.2.2 Eurocontrol DLS Specification, clause D.2.1.4

VDL Mode 2 shall be available, including appropriate transmitter/receiver equipment and used for the air-ground exchange of CPDLC and CM Messages.

### 4.1.6.2.3 Eurocontrol DLS Specification, clause D.2.1.5

Frequency assignments for VDL-Mode 2 operation shall be in accordance with ICAO European agreements Doc 11 [11].

## 4.1.6.3 VDL Mode2 Upper Layer

All functionality identified as "M" (Mandatory) for the ground station support in ARINC 631 [10] Attachment 2 (Data Link Layer PICS) and Attachment 3 (Sub-network Layer PICS) shall be supported.

NOTE: This requirement is identical to clause D.2.1.2 of the Eurocontrol DLS specification [i.11].

## 4.1.6.4 VDL Mode 2 Physical Layer and MAC Sublayer

The VDL Mode 2 ground communications equipment constituent physical layer and MAC sublayer shall comply with the requirements and methods of measurement as defined in EN 301 841-1 [12].

# 4.2 Design Requirements for DLS ground constituents

## 4.2.1 Performance Requirements

The Performance Requirements shall comply with the requirements as defined in EUROCAE ED-120 [7], table A-3.

NOTE 1: The ATS-provider (ATSP) terminology used in ED-120 [7] is equivalent to ATSP **AND** CSP as defined in the present document.

NOTE 2: This requirement is equivalent to Eurocontrol DLS Specification [i.11], clause A.2.1.12.

## 4.2.2 Safety Requirements

The Safety Requirements shall comply with the requirements as defined in EUROCAE ED-120 [7], table A-3.

NOTE 1: The ATS-provider (ATSP) terminology used in ED-120 [7] is equivalent to ATSP **AND** CSP as defined in the present document.

NOTE 2: This requirement is equivalent to Eurocontrol DLS Specification [i.11], clause A.2.1.13.

## 4.2.3 Data Link Services

The Data Link Services to be implemented shall be:

- a) DLIC.
- b) ACM.
- c) ACL.
- d) AMC.

NOTE: Services ACM, ACL and AMC services are part of the CPDLC application.

#### 4.2.3.1 DLIC

NOTE: Section 2.2 of the EUROCONTROL DLS Specification [i.11] explains the DLIC service as follows:

"DLIC is a data link service that is derived from the Context Management Application to provide the necessary information to make data link communications possible between an ATS Unit and aircraft.

The DLIC service makes it possible to:

- Unambiguously associate flight data from the aircraft with flight plan data stored by an ATS Unit.
- Exchange the supported application type and version information and deliver application address information.

Only the Logon and Contact functions of DLIC are within the scope of this EUROCONTROL Specification. (Operational support of the Update function is out of scope, although the associated primitives are handled to the extent necessary for interoperability):

- The Logon service allows the aircraft to initiate the data link service. The logon parameters provide aircraft identification and application addresses to ATS units for identification and flight plan association as well as for use in subsequent CPDLC exchanges.
- The Contact service allows the Ground System to request that an aircraft logon with another Ground System.

The DLIC service is air-initiated, as specified in ED-110B [6].

##### 4.2.3.1.1 Specific Interoperability Requirements

###### 4.2.3.1.1.1 EUROCONTROL DLS Specification, clause A.2.5.1

Implementations of the DLIC service shall comply with the interoperability requirements specified in ED-110B [6] chapter 4.1, except where indicated otherwise in the present document.

###### 4.2.3.1.1.2 EUROCONTROL DLS Specification, clause A.2.5.2

Ground constituents shall have the capability to respond correctly to the DLIC "Logon" service and to initiate the DLIC "Contact" service.

###### 4.2.3.1.1.3 EUROCONTROL DLS Specification, clause A.2.5.5

Ground constituents shall store and process the 24-bit aircraft address independently of the other aircraft identifiers that are used for flight plan association (namely Aircraft ID, Departure and Destination Aerodromes).

###### 4.2.3.1.1.4 EUROCONTROL DLS Specification, clause A.2.5.6

Ground constituents shall perform the flight plan association before issuing a DLIC response.

###### 4.2.3.1.1.5 EUROCONTROL DLS Specification, clause A.2.5.7

Ground Systems shall verify that the 24-bit aircraft address received from the aircraft in the DLIC Logon request matches the address extracted from the corresponding flight plan before issuing a positive DLIC response.

###### 4.2.3.1.1.6 EUROCONTROL DLS Specification, clause A.2.5.10

In case of failure of the inter-centre ground-ground forwarding mechanism, or when this is temporarily not available, ATS Units shall use the DLIC "Contact" service to request the airborne system to establish communications with the next ATC centre.

NOTE: It is an objective to enable an aircraft to log on only once while traversing the applicable airspace. Once an aircraft has logged on, the parameters for data link will be passed between adjacent data link equipped centres using the inter-centre coordination ground-ground forwarding mechanism. Subsequent centres along the route will establish CPDLC services to the aircraft at the appropriate time, without further use of DLIC.

#### 4.2.3.1.2 Specific Performance Requirements

DLIC implementation shall satisfy the performance requirements specified in EUROCAE ED-120 [7], clause 4.3.2 and subpart of table A-3 related to DLIC-performance.

NOTE: This requirement is derived from Eurocontrol DLS Specification [i.11], clause A.2.5.11.

#### 4.2.3.1.3 Specific Safety Requirements

DLIC implementations shall satisfy the safety requirements specified in EUROCAE ED-120 [7], clause 4.2.2 and subpart of table A-3 related to DLIC-safety.

NOTE: This requirement is derived from Eurocontrol DLS Specification [i.11], clause A.2.5.12.

#### 4.2.3.2 ACM

NOTE: Section 2.3 of the EUROCONTROL DLS Specification [i.11] explains the ACM service as follows:

"The ACM service provides automated assistance to flight crew and controllers for conducting the transfer of ATC communications (voice and CPDLC), respecting the operational rule that there is only one ATC controlling authority at any given time. The ACM service permits:

- the initial establishment of CPDLC service between an aircraft and an ATS Unit;
- the transparent transfer of data communications, concurrently with the transfer of voice communications for a flight from one ATS Unit (the Transferring ATS Unit, T-ATSU) to the next ATS Unit (the Receiving ATS Unit, R-ATSU), or the instruction to change voice channels within an ATS Unit or sector;
- the termination of CPDLC with an ATS Unit.

Two variants of the ACM service are described in ED-110B [6], identified as "Case A" and "Case B". The requirement in this EUROCONTROL Specification is to support Case A, in which Transfer instructions are passed without concatenation of the operational instruction UM135 CONFIRM ASSIGNED LEVEL.

Note: ACM Case A corresponds to the agreed operating method in European continental airspace, employed by existing data link programmes. Other regions outside the scope of the DLS implementing rule might require support of Case B, in which Transfer instructions are passed with concatenation of operational instruction UM135 CONFIRM ASSIGNED LEVEL, requiring specific response DM38 ASSIGNED LEVEL. Therefore it is recommended (but not required) that avionics also support Case B, to foster global interoperability.

No explicit mechanism is defined for the ground system to signal to the airborne system that it supports "Case A" procedures. This information is signalled implicitly by the fact that the Transfer instruction does not have a concatenated UM135 CONFIRM ASSIGNED LEVEL message element. Airborne systems, upon detecting the absence of the UM135 element in the Transfer instruction message, will consequently not include a DM38 ASSIGNED LEVEL element in the response message."

#### 4.2.3.2.1 Specific Interoperability Requirements

##### 4.2.3.2.1.1 Eurocontrol DLS Specification, clause A.2.1.11

The Logical Acknowledgement (LACK) messages (downlink message element DM100 and uplink message element UM227) shall be used in ACM message exchanges.

NOTE: The implementation of uplink message UM233 USE OF LOGICAL ACKNOWLEDGEMENT PROHIBITED is therefore not required by ground systems. This requirement does not remove the need for airborne systems to comply with the provisions associated with a "USE OF LOGICAL ACKNOWLEDGEMENT PROHIBITED" response, as other airspace regions may not use LACK.

#### 4.2.3.2.1.2 Eurocontrol DLS Specification, clause A.2.2.1

Implementations of the ACM service shall comply with the air-ground interoperability requirements specified in ED-110B [6], chapters 4.2 and 4.3, except where indicated otherwise in the present document.

NOTE: Interoperability aspects of ground-ground coordination using LOF and NAN messages in support of the ACM service are covered by the OLDI Specification [9].

#### 4.2.3.2.1.3 Eurocontrol DLS Specification, clause A.2.2.2

The ACM service shall be implemented in compliance with "Case A" as specified in ED-110B [6], chapter 4.3.4.

#### 4.2.3.2.1.4 Eurocontrol DLS Specification, clause A.2.2.3

When issuing a data link transfer instruction, compliant ground systems shall therefore send the requisite message element (UM117 CONTACT or UM120 MONITOR) in a CPDLC-End Request without concatenating a UM135 CONFIRM ASSIGNED LEVEL message element.

#### 4.2.3.2.2 ACM Uplink Message Elements

Ground end systems shall allow the sending of the CPDLC message elements as listed in table 10.

**Table 10: ACM Uplink Message Element Support Requirements**

Element ID	Message Element Content	Requirements Conditionality	
		U/C	Condition
UM 117	CONTACT [unitname] [frequency]	U	
UM 159	ERROR [errorInformation]	U	
UM 160	NEXT DATA AUTHORITY [facility]	U	
UM 183	[free text] - see clause 4.2.3.2.2.1 below	U	
UM 227	LOGICAL ACKNOWLEDGEMENT	U	
UM120	MONITOR [unitname] [frequency]	C	It is up to the implementation whether to use it or not.

NOTE 1: Table 10 corresponds to table A-1 of the EUROCONTROL DLS Specification [i.11]. "U" stands for "unconditional", which is equivalent to "mandatory" in the EUROCONTROL DLS Specification [i.11] and means that it has to be supported. "C" stands for "conditional", which is equivalent to "optional" in the EUROCONTROL DLS Specification [i.11] and means that it has to be supported under certain conditions as outlined in table 10.

NOTE 2: This requirement is equivalent to Eurocontrol DLS Specification [i.11], clauses A.2.2.7 and A.2.2.8.

#### 4.2.3.2.2.1 Eurocontrol DLS Specification, clause A.2.2.10

The "free text" content of UM183 when used to indicate the Unit Name in the ACM service shall be formatted as specified in ED-110B [6], chapter 3.3.7.6.2.3.

NOTE: The UM183 text format in the above case is "CURRENT ATC UNIT <facility designation>, <facility name>, <facility function>".



#### 4.2.3.2.3 ACM Downlink Message Elements

Ground end systems shall have the capability to receive and process the message elements as listed in table 11.

**Table 11: ACM Downlink Message Element Support Requirements**

Element ID	Message Element Content	Requirements Conditionality	
		U/C	Condition
DM 0	WILCO	U	
DM 1	UNABLE	U	
DM 2	STANDBY	U	
DM 62	ERROR [errorInformation]	U	
DM 63	NOT CURRENT DATA AUTHORITY	U	
DM 98	[freetext] (for additional error information)	U	
DM 99	CURRENT DATA AUTHORITY	U	
DM 100	LOGICAL ACKNOWLEDGEMENT	U	
DM 107	NOT AUTHORIZED NEXT DATA AUTHORITY	U	
DM 89	MONITORING [unitname] [frequency]	C	It is up to the implementation whether to use it or not.

NOTE 1: Table 11 corresponds to table A-2 of the EUROCONTROL DLS Specification [i.11]. "U" stands for "unconditional", which is equivalent to "mandatory" in the EUROCONTROL DLS Specification [i.11] and means that it has to be supported. "C" stands for "conditional", which is equivalent to "optional" in the EUROCONTROL DLS Specification [i.11] and means that it has to be supported under certain conditions as outlined in table 11.

NOTE 2: This requirement is equivalent to Eurocontrol DLS Specification [i.11], clauses A.2.2.12 and A.2.2.13.

#### 4.2.3.2.4 Specific Performance Requirements

ACM implementation shall satisfy the performance requirements specified in EUROCAE ED-120 [7], clause 5.1.3.2 and subpart of table A-3 related to ACM-performance.

NOTE: This requirement is derived from Eurocontrol DLS Specification [i.11], clause A.2.2.14.

#### 4.2.3.2.5 Specific Safety Requirements

ACM implementations shall satisfy the safety requirements specified in EUROCAE ED-120 [7], clause 5.1.2.3 and subpart of table A-3 related to ACM-safety excluding requirements relating to downstream clearance.

NOTE: This requirement is derived from Eurocontrol DLS Specification [i.11], clause A.2.2.15.

#### 4.2.3.3 ACL

NOTE: Section 2.4 of the EUROCONTROL DLS Specification [i.11] explains the ACL service as follows:

"The ACL service allows flight crews and controllers to conduct operational exchanges. The ACL service permits:

- flight crew to make requests and reports to controllers;
- controllers to issue clearances, instructions and notifications to flight crew.

ACL is intended for use in non-time-critical situations and may be applied instead of or in combination with voice communications.

The ACL service will only be available after successful execution of the ACM service."

#### 4.2.3.3.1 Specific Interoperability Requirements

The Logical Acknowledgement (LACK) messages (downlink message element DM100 and uplink message element UM227) shall be used in ACL message exchanges.

NOTE 1: The implementation of uplink message UM233 USE OF LOGICAL ACKNOWLEDGEMENT PROHIBITED is therefore not required by ground systems. This requirement does not remove the need for airborne systems to comply with the provisions associated with a "USE OF LOGICAL ACKNOWLEDGEMENT PROHIBITED" response, as other airspace regions may not use LACK.

NOTE 2: This requirement is equivalent to Eurocontrol DLS Specification [i.11], clause A.2.1.11.

#### 4.2.3.3.2 ACL Uplink Message Elements

Ground end systems shall allow the sending of the CPDLC message elements as listed in table 12.

**Table 12: ACL Uplink Message Element Support Requirements**

Element ID	Message Element Content	Requirements Conditionality		Response
		U/C	Condition	
UM 0	UNABLE	U		N
UM 1	STANDBY	U		N
UM 19	MAINTAIN [level]	U		W/U
UM 20	CLIMB TO [level]	U		W/U
UM 23	DESCEND TO [level]	U		W/U
UM 74	PROCEED DIRECT TO [position]	U		W/U
UM 159	ERROR [errorInformation]	U		N
UM 162	SERVICE UNAVAILABLE	U		N
UM 183	[freetext] (for additional error information)	U		N
UM 190	FLY HEADING [degrees]	U		W/U
UM 227	LOGICAL ACKNOWLEDGMENT	U		N
UM 3	ROGER	C	It is up to the implementation whether to use it or not.	N
UM 4	AFFIRM	C	It is up to the implementation whether to use it or not.	N
UM 5	NEGATIVE	C	It is up to the implementation whether to use it or not.	N
UM 26	CLIMB TO REACH [level] BY [time]	C	It is up to the implementation whether to use it or not.	W/U
UM 27	CLIMB TO REACH [level] BY [position]	C	It is up to the implementation whether to use it or not.	W/U
UM 28	DESCEND TO REACH [level] BY [time]	C	It is up to the implementation whether to use it or not.	W/U
UM 29	DESCEND TO REACH [level] BY [position]	C	It is up to the implementation whether to use it or not.	W/U
UM 46	CROSS [position] AT [level]	C	It is up to the implementation whether to use it or not.	W/U
UM 47	CROSS [position] AT OR ABOVE [level]	C	It is up to the implementation whether to use it or not.	W/U
UM 48	CROSS [position] AT OR BELOW [level]	C	It is up to the implementation whether to use it or not.	W/U
UM 51	CROSS [position] AT [time]	C	It is up to the implementation whether to use it or not.	W/U
UM 52	CROSS [position] AT OR BEFORE [time]	C	It is up to the implementation whether to use it or not.	W/U
UM 53	CROSS [position] AT OR AFTER [time]	C	It is up to the implementation whether to use it or not.	W/U
UM 54	CROSS [position] BETWEEN [time] AND [time]	C	It is up to the implementation whether to use it or not.	W/U
UM 55	CROSS [position] AT [speed]	C	It is up to the implementation whether to use it or not.	W/U
UM 61	CROSS [position] AT AND MAINTAIN [level] AT [speed]	C	It is up to the implementation whether to use it or not.	W/U
UM 64	OFFSET [specifiedDistance] [direction] OF ROUTE	C	It is up to the implementation whether to use it or not.	W/U

Element ID	Message Element Content	Requirements Conditionality		Response
		U/C	Condition	
UM 72	RESUME OWN NAVIGATION	C	It is up to the implementation whether to use it or not.	W/U
UM 79	CLEARED TO [pos] VIA [route clearance]	C	It is up to the implementation whether to use it or not.	W/U
UM 80	CLEARED [route clearance]	C	It is up to the implementation whether to use it or not.	W/U
UM 82	CLEARED TO DEVIATE UP TO [specifiedDistance] [direction] OF ROUTE	C	It is up to the implementation whether to use it or not.	W/U
UM 92	HOLD AT [position] AS PUBLISHED MAINTAIN [level]	C	It is up to the implementation whether to use it or not.	W/U
UM 94	TURN [direction] HEADING [degrees]	C	It is up to the implementation whether to use it or not.	W/U
UM 96	CONTINUE PRESENT HEADING	C	It is up to the implementation whether to use it or not.	W/U
UM 106	MAINTAIN [speed]	C	It is up to the implementation whether to use it or not.	W/U
UM 107	MAINTAIN PRESENT SPEED	C	It is up to the implementation whether to use it or not.	W/U
UM 108	MAINTAIN [speed] OR GREATER	C	It is up to the implementation whether to use it or not.	W/U
UM 109	MAINTAIN [speed] OR LESS	C	It is up to the implementation whether to use it or not.	W/U
UM 116	RESUME NORMAL SPEED	C	It is up to the implementation whether to use it or not.	W/U
UM 123	SQUAWK [code]	C	It is up to the implementation whether to use it or not.	W/U
UM 133	REPORT PRESENT LEVEL	C	It is up to the implementation whether to use it or not.	Y
UM 148	WHEN CAN YOU ACCEPT [level]	C	It is up to the implementation whether to use it or not.	Y
UM 165	THEN	C	It is up to the implementation whether to use it or not.	N
UM 171	CLIMB AT [verticalRate] MINIMUM	C	It is up to the implementation whether to use it or not.	W/U
UM 172	CLIMB AT [verticalRate] MAXIMUM	C	It is up to the implementation whether to use it or not.	W/U
UM 173	DESCEND AT [verticalRate] MINIMUM	C	It is up to the implementation whether to use it or not.	W/U
UM 174	DESCEND AT [verticalRate] MAXIMUM	C	It is up to the implementation whether to use it or not.	W/U
UM 179	SQUAWK IDENT	C	It is up to the implementation whether to use it or not.	W/U
UM 196	[freetext]	C	It is up to the implementation whether to use it or not.	W/U
UM 203	[freetext]	C	It is up to the implementation whether to use it or not.	R
UM 205	[freetext]	C	It is up to the implementation whether to use it or not.	A/N
UM 211	REQUEST FORWARDED	C	It is up to the implementation whether to use it or not.	N
UM 213	[facilitydesignation] ALTIMETER [altimeter]	C	It is up to the implementation whether to use it or not.	R
UM 215	TURN [direction] [degrees]	C	It is up to the implementation whether to use it or not.	W/U
UM 222	NO SPEED RESTRICTION	C	It is up to the implementation whether to use it or not.	R
UM231	STATE PREFERRED LEVEL	C	It is up to the implementation whether to use it or not.	Y
UM 232	STATE-TOP-OF-DESCENT	C	It is up to the implementation whether to use it or not.	Y
UM 237	REQUEST AGAIN WITH NEXT UNIT	C	It is up to the implementation whether to use it or not.	N

NOTE 1: Table 12 corresponds to table A-3 of the EUROCONTROL DLS Specification [i.11]. "U" stands for "unconditional", which is equivalent to "mandatory" in the EUROCONTROL DLS Specification [i.11] and means that it has to be supported. "C" stands for "conditional", which is equivalent to "optional" in the EUROCONTROL DLS Specification [i.11] and means that it has to be supported under certain conditions as outlined in table 12.

NOTE 2: The "Response" column of table 12 indicates the type of response expected in a subsequent downlink message (see table 13). A complete list of valid responses is given in ICAO Doc 9705 [4], clause 2.3.7.3.4. "W/U" indicates WILCO or UNABLE among other response messages; "A/N" indicates AFFIRM or NEGATIVE among other response messages; "R" indicates ROGER among other response messages; "Y" indicates that a response is requested; "N" indicates No Response (unless LACK required).

NOTE 3: This requirement is equivalent to Eurocontrol DLS Specification [i.11], clauses A.2.3.2 and A.2.3.4.

#### 4.2.3.3.3 ACL Downlink Message Elements

Ground end systems shall have the capability to receive and process the message elements as listed in table 13.

**Table 13: ACL Downlink Message Element Support Requirements**

Element ID	Message Element Content	Requirements Conditionality	
		U/C	Condition
DM 0	WILCO	U	
DM 1	UNABLE	U	
DM 2	STANDBY	U	
DM 6	REQUEST [level]	U	
DM 22	REQUEST DIRECT TO [position]	U	
DM 62	[ERROR [errorInformation]	U	
DM 65	DUE TO WEATHER	U	
DM 66	DUE TO AIRCRAFT PERFORMANCE	U	
DM 98	[freetext] (for additional error information)	U	
DM 100	LOGICAL ACKNOWLEDGEMENT	U	
DM 9	REQUEST CLIMB TO [level]	U	
DM 10	REQUEST DESCENT TO [level]	U	
DM 18	REQUEST [speed]	C	It is up to the implementation whether to use it or not.
DM 27	REQUEST WEATHER DEVIATION UP TO [specifiedDistance] [direction] OF ROUTE	C	It is up to the implementation whether to use it or not.
DM 3	ROGER	C	If uplink messages with response type "R" as indicated in the "Response" column of table 12 are used then DM3 ROGER shall be supported. <i>This requirement is equivalent to Eurocontrol DLS Specification [i.11], clause A.2.3.14.</i>
DM 4	AFFIRM	C	If uplink messages with response type "A/N" or "Y" as indicated in the "Response" column of table 12 are used then DM4 AFFIRM shall be supported. <i>This requirement and the next one are equivalent to Eurocontrol DLS Specification [i.11], clause A.2.3.13.</i>
DM 5	NEGATIVE	C	If uplink messages with response type "A/N" or "Y" as indicated in the "Response" column of table 12 are used then DM5 NEGATIVE shall be supported. <i>This requirement and the previous one are equivalent to Eurocontrol DLS Specification [i.11], clause A.2.3.13.</i>

Element ID	Message Element Content	Requirements Conditionality	
		U/C	Condition
DM 32	PRESENT LEVEL [level]	C	Ground systems that implement the sending of UM133 REPORT PRESENT LEVEL shall have the capability to receive and process the message element DM32 PRESENT LEVEL [level]. <i>This requirement is equivalent to Eurocontrol DLS Specification [i.11], clause A.2.3.9.</i>
DM 81	WE CAN ACCEPT [level] AT [i.11] time	C	Ground systems that implement the sending of UM148 WHEN CAN YOU ACCEPT [level] shall have the capability to receive and process the message elements DM81 WE CAN ACCEPT [level] AT [time]. <i>This requirement and the next one are equivalent to Eurocontrol DLS Specification [i.11] clause A.2.3.10.</i>
DM 82	WE CANNOT ACCEPT [level]	C	Ground systems that implement the sending of UM148 WHEN CAN YOU ACCEPT [level] shall have the capability to receive and process the message elements DM82 WE CANNOT ACCEPT [level]. <i>This requirement and the previous one are equivalent to Eurocontrol DLS Specification [i.11], clause A.2.3.10.</i>
DM 106	PREFERRED LEVEL [level]	C	Ground systems that implement the sending of UM231 STATE PREFERRED LEVEL shall have the capability to receive and process the message element DM106 PREFERRED LEVEL [level]. <i>This requirement is equivalent to Eurocontrol DLS Specification [i.11], clause A.2.3.11.</i>
DM 109	TOP OF DESCENT [time]	C	Ground systems that implement the sending of UM232 STATE TOP OF DESCENT shall have the capability to receive and process the message element DM109 TOP OF DESCENT [time]. <i>This requirement is equivalent to Eurocontrol DLS Specification [i.11], clause A.2.3.12.</i>

NOTE 1: Table 13 corresponds to table A-4 of the EUROCONTROL DLS Specification [i.11]. "U" stands for "unconditional", which is equivalent to "mandatory" in the EUROCONTROL DLS Specification [i.11] and means that it has to be supported. "C" stands for "conditional", which is equivalent to "optional" in the EUROCONTROL DLS Specification [i.11] and means that it has to be supported under certain conditions as outlined in table 13.

NOTE 2: Ground systems may reject message elements DM27 REQUEST WEATHER DEVIATION UP TO [specifiedDistance] [direction] OF ROUTE and DM18 REQUEST [speed] and return an error response.

NOTE 3: This requirement is equivalent to Eurocontrol DLS Specification [i.11], clauses A.2.3.6 and A.2.3.8.

4.2.3.3.4 Void

4.2.3.3.5 Void

#### 4.2.3.3.6 Specific Performance Requirements

ACL implementation shall satisfy the performance requirements specified in EUROCAE ED-120 [7], clause 5.2.3.2 and subpart of table A-3 related to ACL-performance.

NOTE: This requirement is derived from Eurocontrol DLS Specification [i.11], clause A.2.3.17.

#### 4.2.3.3.7 Specific Safety Requirements

ACL implementation shall satisfy the safety requirements specified in EUROCAE ED-120 [7], chapter 5.2.2.3 and subpart of table A-3 related to ACL-safety with the exception described in clause 4.2.3.3.7.1 of the present document.

NOTE: This requirement is derived from Eurocontrol DLS Specification [i.11], clause A.2.3.18.

##### 4.2.3.3.7.1 Eurocontrol DLS Specification, clause A.2.3.19

ACL Safety Requirement SR-ACL-22 as defined in ED-120 [7], table 5-29 shall apply only to Safety Objective SO-ACM-4, and not to SO-ACL-15.

NOTE 1: Experience of the mitigation of hazards resulting from out of sequence execution of clearances (H-ACL-15) has shown that SR-ACL-22 ("Messages shall be transmitted/received in the order that they are sent") does not apply to Safety Objective SO-ACL-15 ("The likelihood of undetected out of sequence messages used for separation shall be no greater than remote"). As result, SR-ACL-22 only applies to SO-ACM-4, hazard class 4. There is hence no need to place reliance on the communications service for the delivery of messages in the same order in which they were dispatched. SO-ACL-15 (responding to H-ACL-15) is to ensure that the controller's intent as to the order of execution of dependent clearances is preserved during the execution of the clearances by the pilot. As clearances/messages could be responded to in a different order than the one in which they were received, when there is a need to issue a clearance that is dependent on the successful outcome of a clearance that had been issued earlier, the controller is required to wait until the execution of that earlier clearance has been completed before the new clearance is issued.

NOTE 2: This requirement is equivalent to Eurocontrol DLS Specification [i.11], clause A.2.3.19.

#### 4.2.3.4 AMC

NOTE: Section 2.5 of the EUROCONTROL DLS Specification [i.11] explains the AMC service as follows:

"The AMC service allows a controller to send an instruction to all CPDLC equipped aircraft in a given sector, at the same time, in order to instruct flight crews to verify that their voice communication equipment is not blocking the sector's voice channel. This instruction will be issued only to those aircraft for which the controller currently has responsibility.

The AMC service is available to controllers only after execution of the ACM service."

##### 4.2.3.4.1 Specific Interoperability Requirements

Implementations of the AMC service shall comply with the interoperability requirements specified in ED-110B [6], chapters 4.2 and 4.5, except where indicated otherwise elsewhere in the present document.

NOTE: This requirement is equivalent to Eurocontrol DLS Specification [i.11], clause A.2.4.1.

##### 4.2.3.4.2 AMC Uplink Message Elements

Ground end systems shall allow the sending of the CPDLC message elements as listed in table 14.

**Table 14: AMC Uplink Message Element Support Requirements**

Element ID	Message Element Content	Requirements Conditionality	
		U/C	Condition
UM 157	CHECK STUCK MICROPHONE [frequency]	C	UM 157 shall be used in case UM 183 [CHECK STUCK MICROPHONE] is not implemented.
UM 183	freetext [CHECK STUCK MICROPHONE]	C	UM 183 [CHECK STUCK MICROPHONE] shall be used in case UM 157 is not implemented.

NOTE 1: Table 14 corresponds to table A-5 of the EUROCONTROL DLS Specification [i.11]. "U" stands for "unconditional", which is equivalent to "mandatory" in the EUROCONTROL DLS Specification [i.11] and means that it has to be supported. "C" stands for "conditional", which is equivalent to "optional" in the EUROCONTROL DLS Specification [i.11] and means that it has to be supported under certain conditions as outlined in table 14.

NOTE 2: This requirement is equivalent to Eurocontrol DLS Specification [i.11], clauses A.2.4.2 and A.2.4.4.

#### 4.2.3.4.3 Eurocontrol DLS Specification, clause A.2.4.5

The "free text" content of UM183 when used in the AMC service shall be as specified in ED-110B [6], chapter 4.5.3.2.

NOTE: The UM183 text format in the above case is "CHECK STUCK MICROPHONE" with no frequency parameter.

#### 4.2.3.4.4 Specific Performance Requirements

AMC shall satisfy the performance requirements specified in EUROCAE ED-120 [7], clause 5.3.3.2 and subpart of table A-3 related AMC-performance.

NOTE: This requirement is equivalent to Eurocontrol DLS Specification [i.11], clause A.2.4.6.

#### 4.2.3.4.5 Specific Safety Requirements

AMC implementations shall satisfy the safety requirements specified in ED-120 [7], chapter 5.3.2.3 and subpart of table A-3 related to AMC-safety, except that for Ground Systems the safety requirements SR-AMC-9, SR-AMC-10, SR-AMC-11 and SR-AMC-12 are not applicable.

NOTE 1: The exceptions for Ground Systems arise because there are no downlink messages in the AMC service, which could be used in response to the AMC uplink message.

NOTE 2: This requirement is equivalent to Eurocontrol DLS Specification [i.11], clause A.2.4.7.

## 4.3 Associated Procedures

### 4.3.1 Eurocontrol DLS Specification, clause C.2.2.1

Operation of the identified Data Link Services shall comply with the requirements of chapter 14 (Controller-Pilot Data Link Communications - CPDLC) of ICAO Doc. 4444 PANS-ATM [3] and with the requirements of chapter 8 (Aeronautical Mobile Service - Data Link Communications) of ICAO Annex 10, Volume II [1]. This covers provisions for:

- The establishment of CPDLC.
- The exchange of operational CPDLC messages.
- The transfer of CPDLC.
- The temporary discontinuation of the use of CPDLC.

- Failure and shutdown of CPDLC.

#### 4.3.2 Void

#### 4.3.3 Eurocontrol DLS Specification, clause C.2.2.4

Where CPDLC-related voice communications are required, the controller and pilot shall use the appropriate phraseologies as detailed in PANS-ATM [3], section 14.3, whenever possible.

NOTE: (derived from Eurocontrol DLS Specification, clause C.2.2.5) The list of phrases available in PANS-ATM [3], section 14.3 is not intended to be exhaustive, and when circumstances differ, pilots and ATS personnel will be expected to use plain language, which should be as clear and concise as possible, to the level specified in the ICAO language proficiency requirements contained in Annex 1 - Personnel Licensing [i.1], in order to avoid possible confusion by those persons using a language other than one of their national languages.

#### 4.3.4 Eurocontrol DLS Specification, clause C.2.2.6

When there is a need to issue a clearance that is dependent on the successful outcome of a previously issued clearance, the controller shall wait until the execution of that earlier clearance has been completed before the new clearance is issued.

#### 4.3.5 Eurocontrol DLS Specification, clause C.2.3.3

All operational details with respect to the transfer of communications using CPDLC shall be reflected accordingly in Letters of Agreement established between the ATC units concerned.

#### 4.3.6 Eurocontrol DLS Specification, clause C.2.6.3

ATN application entity titles and ATN addresses including LOC, SYS and NSEL values shall be assigned in accordance with the data link services supported.

#### 4.3.7 Eurocontrol DLS Specification, clause C.2.6.4

Ground ATC entities shall be identified by an ICAO Facility Designator and the corresponding CM TSEL value.

#### 4.3.8 Eurocontrol DLS Specification, clause C.2.6.5

Ground system addresses required for the DLIC Logon function shall be included in national aeronautical information publications.

---

## 5 System Testing

NOTE: To get the necessary confidence for their global Declaration of Verification, ANSP will:

- Make sure they get a declaration of suitability for use for each constituent they purchase.
- Conduct end to end tests as described in the present document.

The tests specified hereafter have been designed according to the following approach:

- Only end-to-end tests have been specified.
- Most of the tests have been specified to validate the ATSP domain with a simulator.
- A few requirements are not testable by nature.
- Messages including a parameter will be tested for one given parameter value.



- One high level test sequence has been specified with an aircraft certified in accordance with Commission Regulation (EC) 1702/2003 [14].

The following text explains each of these points.

**Only end-to-end tests have been specified.**

No test cases have been identified at the constituent level, for the following reasons:

- Concerning the constituents of the ATSP domain, the Ground HMI constituent, the Data Recording constituent and the ATM Data Processing constituent, that go far beyond the data link field. Their structure may differ a lot from one ANSP to the other, so that it was impossible to design tests which will fit all implementations. ANSP will be responsible for integrating these constituents and for ensuring the necessary tests at system level. All necessary tests up to the constituent level of the ATSP domain are reputed to have been successfully conducted documented by declaration of suitability for use as for the new constituents, the Ground-ground and Air-ground ATN router constituents and the VDL Mode 2 constituent, they will be delivered together with a declaration of suitability for use. Therefore all necessary tests up to the constituent level of the CSP domain have been successfully conducted for the issuing of a declaration of suitability for use.

As a conclusion, only end-to-end tests are described in the present document.

**Most of the tests have been specified to validate the ATSP domain with a simulator.**

The most important perimeter to be tested is the ATSP domain, because it includes large and complex constituents used for Air Traffic Management.

A simulator has been considered necessary in order to test error cases.

The simulator will have to act as a real and complete communication chain at the border of the ATSP domain. It will therefore have to implement the applicable standards to dialogue with the Ground-ground ATN Router of the ATSP domain. It is supposed to provide realism at the IS-IS protocol level and not at the pilot HMI level. Any means to make it receive and process the protocol frames from the ATN Router of the ATSP domain and to make it feed the latter in return with understandable data will be acceptable.

**A few requirements are not testable by nature.**

Several requirements in the present document are not testable by nature, e.g. requirements for AIC publication or for conclusion of letter of agreements between ATC units. This is also true for parameter setting: the easiest way to show the assigned value for a parameter within a piece of software is to supply the associated documentation. For these requirements the present document does not give presumption of conformity. In order to prove their compliance with these requirements, ANSP will have to provide paper evidence. Only testable requirements will be covered by tests described in the present document.

**Messages including a parameter will be tested for one given parameter value.**

Many CPDLC messages include parameters. For example, UM20 "CLIMB TO [level]" includes a flight level value. There is no point in testing each and every possible flight level value. A test involving one instance of UM20 message should be enough. More generally messages including a parameter will only be tested once for a given parameter value.

**One test sequence has been specified with an aircraft.**

A test sequence with an aircraft, involving a complete chain from the controller HMI to the pilot HMI with real equipment is necessary as a final check. The aim of this test sequence is to ensure that a subset of tested cases is valid on the "real life" condition. This test sequence does not require the aircraft to be airborne. Moreover it may be organized in one or several test event(s) depending on organization constraints.

The coverage of the requirements of the present document directly offered by the specified tests described below is presented in details in annex C.

5.1 Void

5.2 Void

### 5.3 Test configuration with simulator

The complete communication chain is outlined in figure 1 (clause 4.1 of the present document). The test configuration with simulator reflects the half harness configuration (see figure 2).

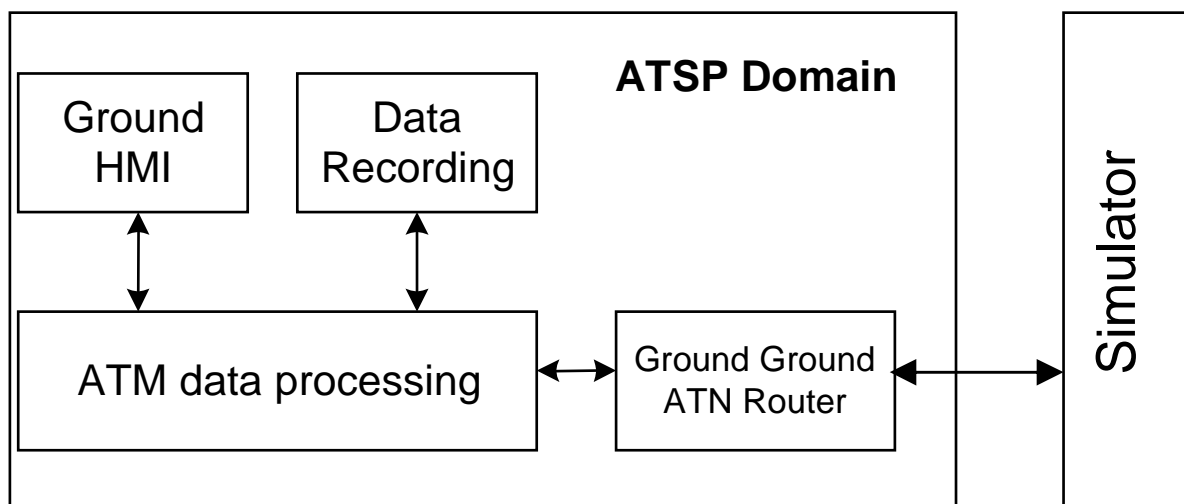

Figure 2: Test configuration with simulator

#### 5.3.1 Test for CM Application

The following tests shall be performed.

<b>Name</b>	CM-logon: nominal case		
<b>Identifier</b>	CM_001		
<b>Purpose:</b>	The purpose of the test is to check the Ground System correctly handles the CM-logon service.		
<b>Preamble:</b>	It is assumed that AIRCRAFT1 is authorized to logon to GND1. As required by ED-110B, the logon request shall provide the optional ADEP and ADES fields.		
<b>Steps:</b>			
<b>No</b>	<b>System</b>	<b>Action</b>	<b>Description</b>
1	AIRCRAFT1	ENTER	AIRCRAFT1 sends a CM-logon request to GND1.
2	GND1	VERIFY	Check GND1 receives the CM-logon indication from AIRCRAFT1.
3	GND1	ENTER	GND1 responds with a positive CM-logon response to AIRCRAFT1.
4	AIRCRAFT1	VERIFY	Check AIRCRAFT1 receives an accepted CM-logon confirmation message providing supported applications by GND1.
5	GND1	VERIFY	Check on ground side that AIRCRAFT1 appears logged on GND1.

<b>Name</b>		CM-logon: rejected response	
<b>Identifier:</b>		CM_002	
<b>Purpose:</b>		The purpose of the test is to check the Ground System correctly generates a negative CM-logon-response.	
<b>Preamble:</b>		The Ground System is configured in order to reject the logon request from AIRCRAFT1 (for instance, AIRCRAFT1 not authorized to logon).	
<b>Steps:</b>			
<b>No</b>	<b>System</b>	<b>Action</b>	<b>Description</b>
1	AIRCRAFT1	ENTER	AIRCRAFT1 sends a CM-logon request to GND1.
2	GND1	VERIFY	Check the GND1 receives the CM-logon indication from AIRCRAFT1.
3	GND1	ENTER	GND1 responds with a rejected CM-logon response to AIRCRAFT1.
4	AIRCRAFT1	VERIFY	Check no application information is transmitted.
5	GND1	VERIFY	Check AIRCRAFT1 is not logged on GND1.

<b>Name</b>		CM-contact: successful	
<b>Identifier</b>		CM_003	
<b>Purpose:</b>		The purpose of this test is to check the Ground System correctly handles the CM-contact service when it is implemented.	
<b>Preamble:</b>		It is assumed AIRCRAFT1 is already logged to GND1. It is assumed AIRCRAFT1 is authorized to logon to GND2. CM-Contact request message is triggered upon events based on local conditions. To perform this test, GND1 is configured to match such local conditions. In case the AIRCRAFT1 is a simulated entity steps 3 to 6 could be skipped.	
<b>Steps:</b>			
<b>No</b>	<b>System</b>	<b>Action</b>	<b>Description</b>
1	GND1	ENTER	Send the CM-contact request to AIRCRAFT1 to reach next ATSU.
2	AIRCRAFT1	VERIFY	Check AIRCRAFT1 receives the CM-contact indication from GND1.
3	AIRCRAFT1	ENTER	AIRCRAFT1 sends a CM-logon request to GND2.
4	GND2	VERIFY	Check GND2 receives a CM-logon indication from AIRCRAFT1.
5	GND2	ENTER	GND2 responds with a CM-logon response to AIRCRAFT1 providing supported application information.
6	AIRCRAFT1	VERIFY	Check AIRCRAFT1 receives the CM-logon confirmation from GND2 providing supported application information.
7	AIRCRAFT1	ENTER	AIRCRAFT1 sends a successful CM-contact response to GND1.
8	GND1	VERIFY	Check GND1 receives a successful CM-contact confirmation from AIRCRAFT1.

<b>Name</b>		CM-contact: not successful	
<b>Identifier</b>		CM_004	
<b>Purpose:</b>		The purpose of the test is to check the Ground System correctly handles an unsuccessful CM-contact response.	
<b>Preamble:</b>		It is assumed AIRCRAFT1 is already logged to GND1. It is assumed AIRCRAFT1 is authorized to logon to GND2. It is assumed GND2 system is not ATN connected. CM-Contact request message is triggered upon events based on local conditions. To perform this test, GND1 is configured to match such local conditions. In case the AIRCRAFT1 is a simulated entity steps 3 and 4 could be skipped.	
<b>Steps:</b>			
<b>No</b>	<b>System</b>	<b>Action</b>	<b>Description</b>
1	GND1	ENTER	Send the CM-contact request to AIRCRAFT1 to reach GND2 system.
2	AIRCRAFT1	VERIFY	Check AIRCRAFT1 receives the CM-contact indication from GND1.
3	AIRCRAFT1	ENTER	AIRCRAFT1 sends a CM-logon request to GND2.
4	AIRCRAFT1	WAIT	Termination of the <i>t<sub>Logon</sub></i> timer value.
5	AIRCRAFT1	ENTER	AIRCRAFT1 sends an unsuccessful CM-contact response to GND1.
6	GND1	VERIFY	Check GND1 receives an unsuccessful CM-contact confirmation from AIRCRAFT1.
7	GND1	VERIFY	Check AIRCRAFT1 is still logged on GND1.

## 5.3.2 Test for CPDLC Application

### 5.3.2.1 Test for CPDLC Connection Handling

The following tests shall be performed.

<b>Name</b>	CPDLC connection: accepted		
<b>Identifier</b>	CPDLC_001		
<b>Purpose:</b>	The purpose of this test is to verify the Ground System correctly handles the CPDLC connection procedure with a logged aircraft. In this test, the request is accepted. This test also includes the CPDLC message exchanges allowing to consider CPDLC enabled (assignment of the Ground System as CDA, provision of the unit name of the R-ATSU).		
<b>Preamble:</b>	It is assumed that AIRCRAFT1 is already logged to the Ground System (c.f. test CM_N010).		
<b>Steps:</b>			
<b>No</b>	<b>System</b>	<b>Action</b>	<b>Description</b>
1	GND1	ENTER	Send a CPDLC-start request to AIRCRAFT1 (no CPDLC message element provided).
2	AIRCRAFT1	VERIFY	Check AIRCRAFT1 receives the CPDLC-start indication (no CPDLC message element provided) from GND1.
3	AIRCRAFT1	ENTER	Send an accepted CPDLC-start response to GND1.
4	GND1	VERIFY	Check GND1 receives the accepted CPDLC-start confirmation from AIRCRAFT1.
5	AIRCRAFT1	ENTER	Send the DM99 CURRENT DATA AUTHORITY message to GND1.
6	GND1	VERIFY	Check GND1 receives the DM99 CURRENT DATA AUTHORITY message from AIRCRAFT1.
7	GND1	ENTER	Send the UM227 LACK message to AIRCRAFT1 to acknowledge DM99 CURRENT DATA AUTHORITY message.
8	AIRCRAFT1	VERIFY	Check AIRCRAFT1 receives the UM227 LACK message from GND1 acknowledging the DM99 CURRENT DATA AUTHORITY message.
9	GND1	ENTER	Send the UM183 'CURRENT ATC UNIT facility designation, facility name, facility function' message to AIRCRAFT1.
10	AIRCRAFT1	VERIFY	Check AIRCRAFT1 receives the UM183 'CURRENT ATC UNIT facility designation, facility name, facility function' message.
11	AIRCRAFT1	ENTER	Send the DM100 LACK message to acknowledge the UM183 'CURRENT ATC UNIT facility designation, facility name, facility function' message.
12	GND1	VERIFY	Check GND1 receives the DM100 LACK message acknowledging the UM183 'CURRENT ATC UNIT facility designation, facility name, facility function' message.
13	GND1	VERIFY	Check AIRCRAFT1 appears as logged on and CPDLC connected to GND1.
<b>Comments:</b> It is assumed that required local conditions (ASSUME input, etc.) are met to consider CPDLC enabled. Some implementations do not require a LACK to the UM183 in step 11.			

<b>Name</b>		CPDLC connection: rejected	
<b>Identifier</b>		CPDLC_002	
<b>Purpose:</b>		The objective of this test is to check the Ground System correctly handles the CPDLC connection procedure when it is rejected by the Aircraft.	
<b>Preamble:</b>		It is assumed AIRCRAFT1 is logged to the Ground System.	
<b>Steps:</b>			
<b>No</b>	<b>System</b>	<b>Action</b>	<b>Description</b>
1	GND1	ENTER	Send the CPDLC-start request to AIRCRAFT1 (no CPDLC message element provided).
2	AIRCRAFT1	VERIFY	Check AIRCRAFT1 receives the CPDLC-start request indication from GND1 (no CPDLC message element provided).
3	AIRCRAFT1	ENTER	Send the rejected CPDLC-start response to GND1, including a CPDLC message containing the concatenation of message element DM62 ERROR [errorInformation] with the choice (2) followed by message element DM98 'AIRCREW HAS INHIBITED CPDLC'.
4	GND1	VERIFY	Check GND1 receives the rejected CPDLC-start confirmation message from AIRCRAFT1 including a CPDLC message containing the concatenation of message element DM62 ERROR [errorInformation] with the choice (2) followed by message element DM98 'AIRCREW HAS INHIBITED CPDLC'.
5	GND1	VERIFY	Check CPDLC connection with AIRCRAFT1 remains closed.

<b>Name:</b>		Rejected CPDLC connection ending request with pending dialogue	
<b>Identifier</b>		CPDLC_003	
<b>Purpose:</b>		The objective of this test is to verify the Ground System correctly handles the CPDLC-end service when a pending dialog exists.	
<b>Preamble:</b>		It is assumed the AIRCRAFT1 is already logged and CPDLC connected to the Ground System.	
<b>Steps:</b>			
<b>No</b>	<b>System</b>	<b>Action</b>	<b>Description</b>
1	GND1	ENTER	Send the CPDLC-end request to AIRCRAFT1.
2	AIRCRAFT1	ENTER	Send the DM6 REQUEST [level] message to GND1.
3	GND1	VERIFY	Check GND1 receives the DM6 REQUEST [level] message and does not respond it.
4	AIRCRAFT1	VERIFY	Check AIRCRAFT1 receives the CPDLC-end indication from GND1.
5	AIRCRAFT1	ENTER	Send the rejected CPDLC-end response to GND1.
6	GND1	VERIFY	Check GND1 receives the rejected CPDLC-end confirmation from AIRCRAFT1.
7	GND1	ENTER	Send the UM20 CLIMB TO [level] message to AIRCRAFT1.
8	AIRCRAFT1	VERIFY	Check AIRCRAFT1 receives the UM20 CLIMB TO [level] message from GND1.
9	AIRCRAFT1	ENTER	Send the DM100 LACK message to acknowledge the UM20 CLIMB TO [level] message.
10	AIRCRAFT1	ENTER	Send the DM0 WILCO message to GND1 in response to the UM20 CLIMB TO [level] message.
11	GND1	VERIFY	Check GND1 receives the DM0 WILCO message in response to the UM20 CLIMB TO [level] message.
12	GND1	ENTER	Send the UM227 LACK message to AIRCRAFT1 to acknowledge the DM0 WILCO message.
13	AIRCRAFT1	VERIFY	Check AIRCRAFT1 receives the UM227 LACK message acknowledging the DM0 WILCO message.
14	GND1	VERIFY	Check the 'level' type dialogue appears as closed on ground display systems.

<b>Name:</b>		CPDLC connection: aborted (ground user)	
<b>Identifier</b>		CPDLC_004	
<b>Purpose:</b>		The goal of this test is to demonstrate that Ground System correctly handles CPDLC user abort primitive. The test is about ground initiated user aborts.	
<b>Preamble:</b>		It is assumed that AIRCRAFT1 is logged and CPDLC connected to the system.	
<b>Steps:</b>			
No	System	Action	Description
1	GND1	ENTER	Send the UM183 'CONTROLLER TERMINATED CPDLC' message then send the CPDLC-user-abort request using the 'commanded-termination' value (5) as abort reason.
2	AIRCRAFT1	VERIFY	Check AIRCRAFT1 receives the UM183 'CONTROLLER TERMINATED CPDLC' message; check AIRCRAFT1 receives the CPDLC-user-abort indication with the 'commanded-termination' value (5) as abort reason.
3	GND1	VERIFY	Check the CPDLC connection with AIRCRAFT1 is closed.
Comments: The user abort in step 1 may be provoked according to local procedures.			

<b>Name:</b>		CPDLC connection: aborted (air user)	
<b>Identifier</b>		CPDLC_005	
<b>Purpose:</b>		The goal of this test is to demonstrate that Ground System correctly handles CPDLC user abort primitive. The test is about air initiated user aborts.	
<b>Preamble:</b>		It is assumed that AIRCRAFT1 is logged and CPDLC connected to the system.	
<b>Steps:</b>			
No	System	Action	Description
1	AIRCRAFT1	ENTER	Send the CPDLC-user-abort request using the 'commanded-termination' value (5) as abort reason.
2	GND1	VERIFY	Check GND1 receives the CPDLC-user-abort indication providing the 'commanded-termination' value (5) as abort reason.
3	GND1	VERIFY	Check the CPDLC connection with AIRCRAFT1 is closed.
4	GND1	VERIFY	Check that Ground System does not attempt to automatically re-establish a CPDLC connection with AIRCRAFT1.

<b>Name:</b>		CPDLC connection: aborted (provider)	
<b>Identifier</b>		CPDLC_006	
<b>Purpose:</b>		The goal of this test is to demonstrate that a CPDLC-provider-abort is correctly handled by Ground System.	
<b>Preamble:</b>		It is assumed AIRCRAFT1 is logged to Ground System.	
<b>Steps:</b>			
No	System	Action	Description
1	GND1	ENTER	Send a CPDLC-start request to AIRCRAFT1.
2	AIRCRAFT	VERIFY	Check AIRCRAFT1 receives the CPDLC-start indication from GND1. Do not respond to the request.
3	GND1	VERIFY	Once the <i>tStart</i> timer fired, check GND1 receives the CPDLC-provider-abort indication message. Check CPDLC connection with AIRCRAFT1 remains closed.
4	GND1	VERIFY	Check the CPDLC connection with AIRCRAFT1 is still closed.

<b>Name:</b>		Timestamp error: future time	
<b>Identifier</b>		CPDLC_007	
<b>Purpose:</b>		This test allows checking that Ground System correctly handles reception of a downlink message that indicates a future time greater than 2 seconds from the current time.	
<b>Preamble:</b>		It is assumed the AIRCRAFT1 is already logged and CPDLC connected to the Ground System. Change the system time of the airborne testing tool workstation so that it indicates a future time greater than 2 seconds from the GND1 workstation.	
<b>Steps:</b>			
No	System	Action	Description
1	AIRCRAFT1	ENTER	Send the DM6 REQUEST [level] message. This message header is filled with a time stamp indicating a difference of more than 2 seconds from the GND1 current time.
2	GND1	VERIFY	Check GND1 receives the DM6 REQUEST [level] message.
3	GND1	ENTER	Send a CPDLC uplink message containing the concatenation of message element UM159 (ERROR (error information)) with the choice (2) followed by message element UM183 (DOWNLINK TIMESTAMP INDICATES FUTURE TIME).
4	AIRCRAFT1	VERIFY	Check AIRCRAFT1 receives the concatenation of message element UM159 (ERROR (error information)) with the choice (2) followed by message element UM183 (DOWNLINK TIMESTAMP INDICATES FUTURE TIME).
5	GND1	VERIFY	Check the CPDLC 'level' type dialogue is closed.

<b>Name:</b>		Message set error (unsupported message)	
<b>Identifier</b>		CPDLC_008	
<b>Purpose:</b>		This test checks Ground System correctly rejects a downlink message that is not in the LINK2000+ CPDLC message set.	
<b>Preamble:</b>		It is assumed the AIRCRAFT1 is already logged and CPDLC connected to the Ground System.	
<b>Steps:</b>			
No	System	Action	Description
1	AIRCRAFT1	ENTER	Send the DM7 REQUEST BLOCK [level] TO [level] message.
2	GND1	VERIFY	Check the GND1 receives the DM7 REQUEST BLOCK [level] TO [level] message from AIRCRAFT1.
3	GND1	ENTER	Send the UM162 SERVICE UNAVAILABLE to AIRCRAFT1.
4	AIRCRAFT1	VERIFY	Check AIRCRAFT1 receives UM162 SERVICE UNAVAILABLE.
5	GND1	VERIFY	Check the CPDLC 'level' type dialogue is closed.

<b>Name:</b>	Concatenation error: more than 2 concatenated message elements		
<b>Identifier</b>	CPDLC_009		
<b>Purpose:</b>	The purpose of this test is to check that reception of a downlink concatenated message with more than 2 message elements is correctly rejected by Ground System.		
<b>Preamble:</b>	It is assumed that AIRCRAFT1 is already logged and CPDLC connected to Ground System.		
<b>Steps:</b>			
<b>No</b>	<b>System</b>	<b>Action</b>	<b>Description</b>
1	AIRCRAFT1	ENTER	Send the CPDLC-message request providing the following concatenated content: DM18 REQUEST [speed] + DM65 DUE TO WEATHER + DM66 DUE TO AIRCRAFT PERFORMANCE.
2	GND1	VERIFY	Check GND1 receives the CPDLC-message indication providing the following: DM18 REQUEST [speed] + DM65 DUE TO WEATHER + DM66 DUE TO AIRCRAFT PERFORMANCE.
3	GND1	ENTER	Send the CPDLC-message request providing the concatenation of message element UM159 ERROR (error information) with the choice (2) followed by message element UM183 'DOWNLINK MESSAGE REJECTED - SEND 2 ELEMENTS MAX.'
4	AIRCRAFT1	VERIFY	Check AIRCRAFT1 receives the CPDLC-message indication providing the concatenation of message element UM159 ERROR (error information) with the choice (2) followed by message element UM183 'DOWNLINK MESSAGE REJECTED - SEND 2 ELEMENTS MAX.' Check CPDLC dialogue is closed.
5	GND1	VERIFY	Check the dialogue is closed on ground display systems.

<b>Name:</b>	Concatenation error: invalid concatenation		
<b>Identifier</b>	CPDLC_0010		
<b>Purpose:</b>	The purpose of this test is to verify that reception of a downlink concatenated message with invalid concatenation is correctly rejected by Ground System.		
<b>Preamble:</b>	It is assumed that AIRCRAFT1 is already logged and CPDLC connected to Ground System.		
<b>Steps:</b>			
<b>No</b>	<b>System</b>	<b>Action</b>	<b>Description</b>
1	AIRCRAFT1	ENTER	Send the CPDLC-message request providing the following concatenated content: DM9 REQUEST CLIMB TO [level] + DM10 REQUEST DESCENT TO [level].
2	GND1	VERIFY	Check GND1 receives the CPDLC-message indication providing the following: DM9 REQUEST CLIMB TO [level] + DM10 REQUEST DESCENT TO [level].
3	GND1	ENTER	Send the CPDLC-message request providing the concatenation of message element UM159 ERROR (error information) with the choice (3) followed by the message element UM183 'ELEMENT COMBINATION REJECTED - USE VOICE' in response to the DM9 REQUEST CLIMB TO [level] + DM10 REQUEST DESCENT TO [level].
4	AIRCRAFT1	VERIFY	Check AIRCRAFT1 receives the CPDLC-message indication providing the concatenation of message element UM159 ERROR (error information) with the choice (3) followed by the message element UM183 'ELEMENT COMBINATION REJECTED - USE VOICE'.
5	GND1	VERIFY	Check the CPDLC dialogue is closed.



<b>Name:</b>	Message composition error: duplicated message identifier		
<b>Identifier</b>	CPDLC_0011		
<b>Purpose:</b>	The objective of this test is to check that Ground System correctly handles the reception of a CPDLC message that uses the same message identification number as a previously received downlink message (dialogue still open).		
<b>Preamble:</b>	It is assumed that AIRCRAFT1 is already logged and CPDLC connected to Ground System. From the Air Simulated Tool, disable the automatic increment of the message ID number. The operator will have to fill in the MIN field with desired value.		
<b>Steps:</b>			
<b>No</b>	<b>System</b>	<b>Action</b>	<b>Description</b>
1	AIRCRAFT1	ENTER	Send the DM6 REQUEST [level] message to GND1.
2	GND1	VERIFY	Check the GND1 receives the DM6 REQUEST [level] message from AIRCRAFT1.
3	GND1	ENTER	Send the UM227 LACK message to acknowledge the DM6 REQUEST [level] message.
4	AIRCRAFT1	VERIFY	Check AIRCRAFT1 receives the UM227 LACK message acknowledging the DM6 REQUEST [level] message.
5	AIRCRAFT1	ENTER	Send the DM22 REQUEST DIRECT TO [position] message to GND1 with the same message id number as sent in step #1.
6	GND1	VERIFY	Check the GND1 receives the DM22 REQUEST DIRECT TO [position] message from AIRCRAFT1.
7	GND1	ENTER	Send the CPDLC-user-abort request to AIRCRAFT1 providing the (2)"/duplicate-message-identification-number" abort reason. Check CPDLC connection with AIRCRAFT1 is closed.
8	AIRCRAFT1	VERIFY	Check AIRCRAFT1 receives the CPDLC-user-abort indication providing the (2)"/duplicate-message-identification-number" abort reason. Check CPDLC connection is closed.
9	GND1	VERIFY	Check the CPDLC connection is closed.

<b>Name:</b>	Message composition error: invalid message reference number		
<b>Identifier</b>	CPDLC_0012		
<b>Purpose:</b>	The objective of this test is to check that Ground System correctly handles the reception of a CPDLC message that uses an invalid message reference number (i.e. does not identify any message identification number currently in use).		
<b>Preamble:</b>	It is assumed that AIRCRAFT1 is already logged and CPDLC connected to Ground System.		
<b>Steps:</b>			
<b>No</b>	<b>System</b>	<b>Action</b>	<b>Description</b>
1	GND1	ENTER	Send the UM23 DESCEND TO [level] message to AIRCRAFT1.
2	AIRCRAFT1	VERIFY	Check AIRCRAFT1 receives the UM23 DESCEND TO [level] message from GND1.
3	AIRCRAFT1	ENTER	Send DM100 LACK message to acknowledge UM23 DESCEND TO [level] message.
4	GND1	VERIFY	Check GND1 receives the DM100 LACK message acknowledging UM23 DESCEND TO [level] message.
5	AIRCRAFT1	ENTER	Send DM0 WILCO message with a MRN that does not identify any uplink message identification number.
6	GND1	VERIFY	Check GND1 receives the DM0 WILCO.
7	GND1	SEND	Check GND1 sends an UM159 ERROR [errorInformation] with the choice (0).
8	AIRCRAFT1	VERIFY	Check AIRCRAFT1 receives the UM159 ERROR [errorInformation] with the choice (0) in response to the DM0 WILCO (c.f. step #5).
9	AIRCRAFT1	ENTER	Send the DM0 WILCO in response to the UM23 DESCEND TO [level] message.
10	GND1	VERIFY	Check GND1 receives the DM0 WILCO in response to the UM23 DESCEND TO [level] message.
11	GND1	ENTER	Send the UM227 LACK to acknowledge the DM0 WILCO message.
12	AIRCRAFT1	VERIFY	Check AIRCRAFT1 receives the UM227 LACK acknowledging the DM0 WILCO message.
13	GND1	VERIFY	Check the 'level' dialogue appears as closed on ground display systems.

<b>Name:</b>	Open dialogues of same type (airborne initiated)		
<b>Identifier</b>	CPDLC_0013		
<b>Purpose:</b>	The objective of this test is to verify the Ground System correctly handles reception of a downlink request whereas another same type dialogue is still pending. This test deals with airborne initiated dialogs.		
<b>Preamble:</b>	It is assumed that AIRCRAFT1 is already logged and CPDLC connected to Ground System. When two downlink requests pertain to the same type, ED-110B states that Ground System may reject the first request or second one. This test describes the rejection of the first request.		
<b>Steps:</b>			
<b>No</b>	<b>System</b>	<b>Action</b>	<b>Description</b>
1	AIRCRAFT1	ENTER	Send the DM6 REQUEST [level] message to GND1.
2	GND1	VERIFY	Check the GND1 receives the DM6 REQUEST [level] message from AIRCRAFT1.
3	GND1	ENTER	Send the UM227 LACK message to acknowledge the DM6 REQUEST [level] message.
4	AIRCRAFT1	VERIFY	Check AIRCRAFT1 receives the UM227 LACK message acknowledging the DM6 REQUEST [level] message.
5	AIRCRAFT1	ENTER	Send the DM9 REQUEST CLIMB TO [level] message to GND1.
6	GND1	VERIFY	Check the GND1 receives the DM9 REQUEST CLIMB TO [level] message from AIRCRAFT1.
7	GND1	ENTER	As two level-type dialogs are requested, the GND1 rejects the first one sending the concatenation of message element UM159 ERROR (2) followed by message element UM183 'TOO MANY LEVEL REQUESTS - EXPECT ONLY ONE REPLY'. Check the first level type dialogue appears as closed on both display systems.
8	AIRCRAFT1	VERIFY	Check AIRCRAFT1 receives the concatenation of message element UM159 ERROR (2) followed by message element UM183 'TOO MANY LEVEL REQUESTS - EXPECT ONLY ONE REPLY' in response to the DM6 REQUEST [level] message. Check this dialogue is closed.
<b>Comments:</b> The second dialogue (DM9) is not closed and may be continued. Depending on implementation it is mandatory to either conduct testcase CPDLC_0013 or CPDLC_0014.			

<b>Name:</b>	Open dialogues of same type (airborne initiated)		
<b>Identifier</b>	CPDLC_0014		
<b>Purpose:</b>	The objective of this test is to verify the Ground System correctly handles reception of a downlink request whereas another same type dialogue is still pending. This test deals with airborne initiated dialogs.		
<b>Preamble:</b>	It is assumed that AIRCRAFT1 is already logged and CPDLC connected to Ground System. When two downlink requests pertain to the same type, ED-110B states that Ground System may reject the first request or second one. This test describes the rejection of the second request.		
<b>Steps:</b>			
<b>No</b>	<b>System</b>	<b>Action</b>	<b>Description</b>
1	AIRCRAFT1	ENTER	Send the DM6 REQUEST [level] message to GND1.
2	GND1	VERIFY	Check the GND1 receives the DM6 REQUEST [level] message from AIRCRAFT1.
3	GND1	ENTER	Send the UM227 LACK message to acknowledge the DM6 REQUEST [level] message.
4	AIRCRAFT1	VERIFY	Check AIRCRAFT1 receives the UM227 LACK message acknowledging the DM6 REQUEST [level] message.
5	AIRCRAFT1	ENTER	Send the DM9 REQUEST CLIMB TO [level] message to GND1.
6	GND1	VERIFY	Check the GND1 receives the DM9 REQUEST CLIMB TO [level] message from AIRCRAFT1.
7	GND1	ENTER	As two level-type dialogs are requested, the GND1 rejects the second one sending the concatenation of message element UM159 ERROR (2) followed by message element UM183 'TOO MANY LEVEL REQUESTS - EXPECT ONLY ONE REPLY'. Check the second level type dialogue is closed.
8	AIRCRAFT1	VERIFY	Check AIRCRAFT1 receives the concatenation of message element UM159 ERROR (2) followed by message element UM183 'TOO MANY LEVEL REQUESTS - EXPECT ONLY ONE REPLY' in response to the DM9 REQUEST CLIMB TO [level] message. Check this dialogue is closed.
<b>Comments:</b> The first dialogue (DM6) is not closed and may be continued. Depending on implementation it is mandatory to either conduct testcase CPDLC_0013 or CPDLC_0014.			

<b>Name:</b>	Open dialogues of same type (ground initiated)		
<b>Identifier</b>	CPDLC_0015		
<b>Purpose:</b>	The objective of this test is to verify the Ground System correctly handles reception of a downlink request whereas another same type dialogue is still pending. The first dialogue is a ground initiated one.		
<b>Preamble:</b>	It is assumed that AIRCRAFT1 is already logged and CPDLC connected to Ground System.		
<b>Steps:</b>			
<b>No</b>	<b>System</b>	<b>Action</b>	<b>Description</b>
1	GND1	ENTER	Send the UM20 CLIMB TO [level] message to AIRCRAFT1.
2	AIRCRAFT1	VERIFY	Check AIRCRAFT1 receives the UM20 message.
3	AIRCRAFT1	ENTER	Send the DM100 LACK message to acknowledge the UM20 CLIMB TO [level] message.
4	GND1	VERIFY	Check GND1 receives the DM100 LACK message acknowledging the UM20 CLIMB TO [level] message.
5	AIRCRAFT1	ENTER	Send the DM6 REQUEST [level] message to GND1.
6	GND1	VERIFY	Check the GND1 receives the DM6 REQUEST [level] message from AIRCRAFT1.
7	GND1	ENTER	As two level-type dialogs are requested, one from the ground and the second from the air system, the GND1 rejects the second one sending the concatenation of message element UM159 (2) + UM183 ((dialogue type) REQUEST REJECTED - REPLY TO LEVEL UPLINK FIRST). Check this dialogue is closed.
8	AIRCRAFT1	VERIFY	Check AIRCRAFT1 receives the concatenation of message element UM159 (ERROR (error information)) with the choice (2) followed by message element UM183 ((dialogue type) REQUEST REJECTED - REPLY TO LEVEL UPLINK FIRST). Check this dialogue is closed.
<b>Comments:</b> The first dialogue (UM20) is not closed and may be continued.			

<b>Name:</b>	Application Message Integrity Check (AMIC), invalid 24-bit address sent by the aircraft		
<b>Identifier</b>	CPDLC_0016		
<b>Purpose:</b>	The purpose of the test is to check the Ground System correctly detects a checksum validation failure (invalid 24-bit address) for an air-initiated exchange.		
<b>Preamble:</b>	It is assumed AIRCRAFT1 is already logged and CPDLC connected to GND1. The aircraft is configured with an invalid 24-bit address.		
<b>Steps:</b>			
<b>No</b>	<b>System</b>	<b>Action</b>	<b>Description</b>
1	AIRCRAFT1	ENTER	Send the DM6 REQUEST [level] message to GND1.
2	GND1	VERIFY	Check GND1 receives the DM6 REQUEST [level] message from AIRCRAFT1.
3	GND1	VERIFY	Check the message validation failure is detected and a notification is sent to the controller.
4	GND1	ENTER	Send a CPDLC-user-abort to AIRCRAFT1 with validation failure abort reason.
5	AIRCRAFT1	VERIFY	Check AIRCRAFT1 receives the CPDLC-user-abort indication with validation failure abort reason and CPDLC connection is closed.
6	GND1	VERIFY	Check the CPDLC connection is closed.

<b>Name:</b>	Application Message Integrity Check (AMIC), invalid ground facility designator		
<b>Identifier</b>	CPDLC_0017		
<b>Purpose:</b>	The purpose of the test is to check the Ground System correctly detects a checksum validation failure (invalid ground facility designator) for an air initiated exchange.		
<b>Preamble:</b>	It is assumed AIRCRAFT1 is already logged and CPDLC connected to GND1. From airborne side, configure an invalid ground facility designator.		
<b>Steps:</b>			
<b>No</b>	<b>System</b>	<b>Action</b>	<b>Description</b>
1	AIRCRAFT1	ENTER	Send the DM6 REQUEST [level] message to GND1.
2	GND1	VERIFY	Check GND1 receives the DM6 REQUEST [level] message from AIRCRAFT1.
3	GND1	VERIFY	Check the message validation failure is detected and a notification is sent to the controller.
4	GND1	ENTER	Send a CPDLC-user-abort to AIRCRAFT1 with validation failure abort reason.
5	AIRCRAFT1	VERIFY	Check AIRCRAFT1 receives the CPDLC-user-abort indication with validation failure abort reason, and CPDLC connection is closed.
6	GND1	VERIFY	Check the CPDLC connection is closed.

<b>Name:</b>	Application Message Integrity Check (AMIC), invalid flight id		
<b>Identifier</b>	CPDLC_0018		
<b>Purpose:</b>	The purpose of the test is to check the Ground System correctly detects a checksum validation failure (invalid flight id) for an air-initiated exchange.		
<b>Preamble:</b>	It is assumed AIRCRAFT1 is already logged and CPDLC connected to GND1. From airborne side, configure the aircraft with an invalid flight id.		
<b>Steps:</b>			
<b>No</b>	<b>System</b>	<b>Action</b>	<b>Description</b>
1	AIRCRAFT1	ENTER	Send the DM6 REQUEST [level] message to GND1.
2	GND1	VERIFY	Check GND1 receives the DM6 REQUEST [level] message from AIRCRAFT1.
3	GND1	VERIFY	Check the message validation failure is detected and a notification is sent to the controller.
4	GND1	ENTER	Send a CPDLC-user-abort to AIRCRAFT1 with validation failure abort reason.
5	AIRCRAFT1	VERIFY	Check AIRCRAFT1 receives the CPDLC-user-abort indication with validation failure abort reason, and CPDLC connection is closed.
6	AIRCRAFT1	VERIFY	Check the CPDLC connection is closed.

## 5.3.2.2 CPDLC Timers

The following tests shall be performed.

<b>Name:</b>		CPDLC timer: ground ttr timer	
<b>Identifier</b>		Timer_001	
<b>Purpose:</b>		The purpose of this test is to check that Ground System correctly implements requirements related to the <i>ttr</i> timer.	
<b>Preamble:</b>		It is assumed that AIRCRAFT1 is already logged and CPDLC connected to Ground System. As the test focuses on <i>ttr</i> timer, the steps related to LACK messages exchange will not be detailed.	
<b>Steps:</b>			
No	System	Action	Description
1	AIRCRAFT1	ENTER	Send the DM9 REQUEST CLIMB TO [level] to GND1.
2	GND1	VERIFY	Check GND1 receives the DM9 REQUEST CLIMB TO [level] from AIRCRAFT1. Check GND1 starts <i>ttr</i> timer.
3	GND1	ENTER	Send the UM1 STANDBY to AIRCRAFT1 in response to DM9 REQUEST CLIMB TO [level].
4	GND1	VERIFY	Check GND1 restarts <i>ttr</i> timer.
5	AIRCRAFT1	VERIFY	Check AIRCRAFT1 receives UM1 STANDBY message in response to DM9.
6	GND1	ENTER	Send UM20 CLIMB TO [level] message to AIRCRAFT1 in response to DM9 REQUEST CLIMB TO [level].
7	GND1	VERIFY	Check GND1 stops <i>ttr</i> timer.
8	AIRCRAFT1	VERIFY	Check AIRCRAFT1 receives UM20 CLIMB TO [level] message in response to DM9.
9	AIRCRAFT1	ENTER	Send DM0 WILCO in response to UM20 CLIMB TO [level].
10	GND1	VERIFY	Check GND1 receives DM0 WILCO in response to UM20 CLIMB TO [level].
11	AIRCRAFT1	ENTER	Send the DM10 REQUEST DESCENT TO [level] to GND1.
12	GND1	VERIFY	Check GND1 receives the DM10 REQUEST DESCENT TO [level]. Check GND1 starts <i>ttr</i> timer.
13	GND1	WAIT	Do not respond to DM10 REQUEST DESCENT TO [level].
14	GND1	ENTER	Upon expiry of the <i>ttr</i> timer, check GND1 automatically sends the CPDLC uplink message containing the concatenation of message element UM159 ERROR (error information) with the choice (2) followed by the message element UM183 'ATC TIMEOUT - REPEAT REQUEST'.
15	AIRCRAFT1	VERIFY	Check AIRCRAFT1 receives the message containing the concatenation of message element UM159 ERROR (error information) with the choice (2) followed by the message element UM183 'ATC TIMEOUT - REPEAT REQUEST' in response to the DM10 REQUEST DESCENT TO [level].
16	GND1	VERIFY	Check all AIRCRAFT1 CPDLC dialogues with GND1 are closed.

<b>Name:</b>		CPDLC timer: ground tts timer	
<b>Identifier</b>		Timer_002	
<b>Purpose:</b>		The purpose of this test is to check that Ground System correctly implements requirements related to the <i>tts</i> timer.	
<b>Preamble:</b>		It is assumed that AIRCRAFT1 is already logged and CPDLC connected to Ground System.	
<b>Steps:</b>			
No	System	Action	Description
1	GND1	ENTER	Send the UM19 MAINTAIN [level] message to AIRCRAFT1.
2	AIRCRAFT1	VERIFY	Check AIRCRAFT1 receives the UM19 MAINTAIN [level] message.
3	AIRCRAFT1	ENTER	Send the DM100 LACK to acknowledge the UM19 MAINTAIN [level] message.
4	GND1	VERIFY	Check GND1 receives the DM100 acknowledging the UM19 MAINTAIN [level] message.
4	AIRCRAFT1	WAIT	Wait up to termination of <i>tts</i> timer (do not respond to UM19 message).
6	GND1	VERIFY	Upon termination of the <i>tts</i> timer, check the controller is indicated the required response has not been received within the required time.
7	GND1	VERIFY	Check the 'level' type dialogue appears as closed on air display systems.
<b>Comments:</b> The test case can be conducted by disabling the <i>ttr</i> -timer on the airside, which fires before <i>tts</i> -timer expiry.			

<b>Name:</b>		CPDLC timer: air ttr timer	
<b>Identifier</b>		Timer_003	
<b>Purpose:</b>		The purpose of this test is to check that Ground System correctly handles the reception of error message on airborne <i>ttr</i> timeout.	
<b>Preamble:</b>		It is assumed that AIRCRAFT1 is already logged and CPDLC connected to Ground System.	
<b>Steps:</b>			
No	System	Action	Description
1	GND1	ENTER	Send the UM19 MAINTAIN [level] message to AIRCRAFT1.
2	AIRCRAFT1	VERIFY	Check AIRCRAFT1 receives the UM19 MAINTAIN [level] message.
3	AIRCRAFT1	ENTER	Send the DM100 LACK to acknowledge the UM19 MAINTAIN [level] message.
4	GND1	VERIFY	Check GND1 receives the DM100 acknowledging the UM19 MAINTAIN [level] message.
4	AIRCRAFT1	WAIT	Wait up to termination of <i>ttr</i> timer (do not respond to UM19 message).
6	AIRCRAFT1	ENTER	Upon termination of the <i>ttr</i> timer, send the DM62 ERROR [errorInformation] with the choice (2) followed by message element DM98 'AIR SYSTEM TIMEOUT'.
7	GND1	VERIFY	Check GND1 receives the DM62 ERROR [errorInformation] with the choice (2) followed by message element DM98 'AIR SYSTEM TIMEOUT' in response to UM19 MAINTAIN [level]. Check the dialogue is closed.
8	GND1	VERIFY	Check the 'level' type dialogue appears as closed on ground display systems.

<b>Name:</b>		CPDLC timer: ground tr timer	
<b>Identifier</b>		Timer_004	
<b>Purpose:</b>		The goal of this test is to check that Ground System correctly implements requirements related to the <i>tr</i> timer. From steps #1 to #10, the test describes a nominal case of <i>tr</i> timer management. From step #11 to the end, the test describes an error case of <i>tr</i> timer management (no response until termination of <i>tr</i> timer).	
<b>Preamble:</b>		As ED-110B states that implementation of <i>tr</i> timer is a local matter, this test is applicable only if the Ground System implements the <i>tr</i> timer. It is assumed that AIRCRAFT1 is already logged and CPDLC connected to Ground System.	
<b>Steps:</b>			
No	System	Action	Description
1	GND1	ENTER	Send the UM20 CLIMB TO [level] (LACK is required) to AIRCRAFT1.
2	GND1	VERIFY	Check <i>tr</i> timer is started.
3	AIRCRAFT1	VERIFY	Check AIRCRAFT1 receives the UM20 CLIMB TO [level] message.
4	AIRCRAFT1	ENTER	Send DM100 LACK message to acknowledge UM20 CLIMB TO [level] message.
5	GND1	VERIFY	Check GND1 receives DM100 LACK message acknowledging the UM20 CLIMB TO [level] message.
6	GND1	VERIFY	Check <i>tr</i> timer is cancelled.
7	AIRCRAFT1	ENTER	Send DM0 WILCO in response to UM20.
8	GND1	VERIFY	Check GND1 received the DM0 WILCO message in response to UM20.
9	GND1	ENTER	Send UM227 LACK message to acknowledge DM0 WILCO.
10	AIRCRAFT1	VERIFY	Check AIRCRAFT1 receives the UM227 message in response to DM0 WILCO.
11	GND1	ENTER	Send the UM23 DESCEND TO [level] (LACK is required) to AIRCRAFT1.
12	GND1	VERIFY	Check <i>tr</i> timer is started.
13	AIRCRAFT1	VERIFY	Check AIRCRAFT1 receives the UM23 DESCEND TO [level] message.
14	AIRCRAFT1	WAIT	No action (do not respond) before at least the duration of the <i>tr</i> timer.
15	GND1	VERIFY	At the end of the <i>tr</i> timer, check GND1 notifies the controller of no reception of DM100 LACK.
16	GND1	VERIFY	Check the 'level' type dialogue is closed on ground side.

### 5.3.3 ACL Service

The following tests shall be performed.

<b>Name:</b>		Dialogue type: 'level', air initiated	
<b>Identifier</b>		ACL_001	
<b>Purpose:</b>		The purpose of the test is to check the Ground System correctly handles a 'level' type dialogue. This ACL dialogue is initiated by airborne side.	
<b>Preamble:</b>		It is assumed AIRCRAFT1 is already logged and CPDLC connected to GND1.	
<b>Steps:</b>			
No	System	Action	Description
1	AIRCRAFT1	ENTER	Send the DM6 REQUEST [level] message to GND1.
2	GND1	VERIFY	Check GND1 receives the DM6 REQUEST [level] message from AIRCRAFT1.
3	GND1	ENTER	Send UM227 LACK message to acknowledge DM6 REQUEST [level] message.
4	AIRCRAFT1	VERIFY	Check AIRCRAFT1 receives the UM227 LACK message, acknowledging DM6 REQUEST [level] message.
5	GND1	ENTER	Send UM20 CLIMB TO [level] to AIRCRAFT1 in response to DM6 REQUEST [level] message.
6	AIRCRAFT	VERIFY	Check AIRCRAFT1 receives UM20 CLIMB TO [level] in response to DM6 REQUEST [level] message.
7	AIRCRAFT1	ENTER	Send DM100 LACK message to acknowledge UM20 CLIMB TO [level] message.
8	GND1	VERIFY	Check GND1 receives DM100 LACK message, acknowledging UM20 CLIMB TO [level] message.
9	AIRCRAFT1	ENTER	Send DM0 WILCO message in response to UM20 CLIMB TO [level] message.
10	GND1	VERIFY	Check GND1 receives DM0 WILCO message in response to UM20 CLIMB TO [level] message.
11	GND1	ENTER	Send UM227 LACK message to acknowledge the DM0 WILCO message.
12	AIRCRAFT1	VERIFY	Check AIRCRAFT1 receives the UM227 LACK message, acknowledging the DM0 WILCO message.
13	GND1	VERIFY	Check this 'level' type dialogue appears as closed on ground display systems.

<b>Name:</b>		Dialogue type: 'route', air initiated	
<b>Identifier</b>		ACL_002	
<b>Preamble:</b>		It is assumed AIRCRAFT1 is already logged and CPDLC connected to GND1.	
<b>Steps:</b>			
No	System	Action	Description
1	AIRCRAFT1	ENTER	Send the DM22 REQUEST DIRECT TO [position] message to GND1.
2	GND1	VERIFY	Check GND1 receives the DM22 REQUEST DIRECT TO [position] message from AIRCRAFT1.
3	GND1	ENTER	Send UM227 LACK message to acknowledge DM22 REQUEST DIRECT TO [position] message.
4	AIRCRAFT1	VERIFY	Check AIRCRAFT1 receives the UM227 LACK message, acknowledging DM22 REQUEST DIRECT TO [position] message.
5	GND1	ENTER	Send UM1 STANDBY to AIRCRAFT1.
6	AIRCRAFT1	VERIFY	Check AIRCRAFT1 receives the UM1 STANDBY message.
7	AIRCRAFT1	ENTER	Send DM100 LACK message to acknowledge UM1 STANDBY message.
8	GND1	VERIFY	Check GND1 receives DM100 LACK message, acknowledging UM1 STANDBY message.
9	GND1	ENTER	Send UM0 UNABLE to AIRCRAFT1.
10	AIRCRAFT1	VERIFY	Check AIRCRAFT1 receives the UM0 UNABLE message.
11	AIRCRAFT1	ENTER	Send DM100 LACK message to acknowledge UM0 UNABLE message.
12	GND1	VERIFY	Check GND1 receives DM100 LACK message, acknowledging UM0 UNABLE message.
13	GND1	VERIFY	Check the 'route' type dialogue is closed.



<b>Name:</b>	Concatenated message elements, air initiated (1)		
<b>Identifier</b>	ACL_003		
<b>Purpose:</b>	The purpose of this test is to check that Ground System correctly handles messages conveying concatenated message elements.		
<b>ED110B Requirements:</b>	3.3.7.3.2/3.3.7.3.3		
<b>Preamble:</b>	It is assumed that AIRCRAFT1 is already logged and CPDLC connected to Ground System.		
<b>Steps:</b>			
<b>No</b>	<b>System</b>	<b>Action</b>	<b>Description</b>
1	AIRCRAFT1	ENTER	Send the CPDLC-message request providing the following concatenated content: DM22 REQUEST DIRECT TO [position] + DM65 DUE TO WEATHER.
2	GND1	VERIFY	Check GND1 receives the CPDLC-message indication providing the following: DM22 REQUEST DIRECT TO [position] + DM65 DUE TO WEATHER.
3	GND1	ENTER	Send the UM227 LACK message to AIRCRAFT1 to acknowledge DM22 REQUEST DIRECT TO [position] + DM65 DUE TO WEATHER message.
4	AIRCRAFT1	VERIFY	Check AIRCRAFT1 receives the UM227 LACK message from GND1 acknowledging the DM22 REQUEST DIRECT TO [position] + DM65 DUE TO WEATHER message.
5	GND1	ENTER	Send the UM74 PROCEED DIRECT TO [position] in response to the DM22 REQUEST DIRECT TO [position] + DM65 DUE TO WEATHER message.
6	AIRCRAFT1	VERIFY	Check AIRCRAFT1 receives the UM74 PROCEED DIRECT TO [position] message.
7	AIRCRAFT1	ENTER	Send the DM100 LACK to acknowledge the UM74 PROCEED DIRECT TO [position] message.
8	GND1	VERIFY	Check GND1 receives the DM100 LACK acknowledging the UM74 PROCEED DIRECT TO [position] message.
9	AIRCRAFT1	ENTER	Send the DM0 WILCO message in response to the UM74 PROCEED DIRECT TO [position] message.
10	GND1	VERIFY	Check GND1 receives the DM0 WILCO message in response to the UM74 PROCEED DIRECT TO [position] message.
11	GND1	ENTER	Send the UM227 LACK message to acknowledge the UM74 PROCEED DIRECT TO [position] message.
12	AIRCRAFT1	VERIFY	Check AIRCRAFT1 receives the UM227 LACK message acknowledging the UM74 PROCEED DIRECT TO [position] message.
13	GND1	VERIFY	Check the 'route' type dialogue is closed.

<b>Name:</b>	Concatenated message elements, air initiated (2)		
<b>Identifier</b>	ACL_004		
<b>Preamble:</b>	It is assumed that AIRCRAFT1 is already logged and CPDLC connected to Ground System.		
<b>Steps:</b>			
<b>No</b>	<b>System</b>	<b>Action</b>	<b>Description</b>
1	AIRCRAFT1	ENTER	Send the CPDLC-message request providing the following concatenated content: DM9 REQUEST CLIMB TO [level] + DM22 REQUEST DIRECT TO [position].
2	GND1	VERIFY	Check GND1 receives the CPDLC-message indication providing the following: DM9 REQUEST CLIMB TO [level] + DM22 REQUEST DIRECT TO [position].
3	GND1	ENTER	Send the UM227 LACK message to AIRCRAFT1 to acknowledge DM9 REQUEST CLIMB TO [level] + DM22 REQUEST DIRECT TO [position] message.
4	AIRCRAFT1	VERIFY	Check AIRCRAFT1 receives the UM227 LACK message from GND1 acknowledging the DM9 REQUEST CLIMB TO [level] + DM22 REQUEST DIRECT TO [position] message.
5	GND1	ENTER	Send the UM20 CLIMB TO [level] + UM74 PROCEED DIRECT TO [position] in response to the DM9 REQUEST CLIMB TO [level] + DM22 REQUEST DIRECT TO [position] message.
6	AIRCRAFT1	VERIFY	Check AIRCRAFT1 receives the UM20 CLIMB TO [level] + UM74 PROCEED DIRECT TO [position] message.
7	AIRCRAFT1	ENTER	Send the DM100 LACK to acknowledge the UM20 CLIMB TO [level] + UM74 PROCEED DIRECT TO [position] message.
8	GND1	VERIFY	Check GND1 receives the DM100 LACK acknowledging the UM20 CLIMB TO [level] + UM74 PROCEED DIRECT TO [position] message.
9	AIRCRAFT1	ENTER	Send the DM0 WILCO message in response to the UM20 CLIMB TO [level] + UM74 PROCEED DIRECT TO [position] message.
10	GND1	VERIFY	Check GND1 receives the DM0 WILCO message in response to the UM20 CLIMB TO [level] + UM74 PROCEED DIRECT TO [position] message.
11	GND1	ENTER	Send the UM227 LACK message to acknowledge the UM20 CLIMB TO [level] + UM74 PROCEED DIRECT TO [position] message.
12	AIRCRAFT1	VERIFY	Check AIRCRAFT1 receives the UM227 LACK message acknowledging the UM20 CLIMB TO [level] + UM74 PROCEED DIRECT TO [position] message.
13	GND1	VERIFY	Check on both sides the CPDLC dialogue appears as closed on ground display systems.
Comments: Depending on implementation it is mandatory to either conduct testcase ACL_004 or ACL_005.			

<b>Name:</b>	Concatenated message elements, air initiated (3)		
<b>Identifier</b>	ACL_005		
<b>Purpose:</b>	The purpose of this test is to check that Ground System correctly handles messages conveying concatenated message elements.		
<b>Configuration:</b>	RTC		
<b>ED110B Requirements:</b>	3.3.7.3.2/3.3.7.3.3		
<b>Preamble:</b>	It is assumed that AIRCRAFT1 is already logged and CPDLC connected to Ground System.		
<b>Steps:</b>			
<b>No</b>	<b>System</b>	<b>Action</b>	<b>Description</b>
1	AIRCRAFT1	ENTER	Send the CPDLC-message request providing the following concatenated content: DM9 REQUEST CLIMB TO [level] + DM22 REQUEST DIRECT TO [position].
2	GND1	VERIFY	Check GND1 receives the CPDLC-message indication providing the following: DM9 REQUEST CLIMB TO [level] + DM22 REQUEST DIRECT TO [position].
3	GND1	ENTER	Send the UM162 SERVICE UNAVAILABLE message to AIRCRAFT1.
4	AIRCRAFT1	VERIFY	Check AIRCRAFT1 receives the UM162 SERVICE UNAVAILABLE message from GND1 acknowledging the DM9 REQUEST CLIMB TO [level] + DM22 REQUEST DIRECT TO [position] message.
5	GND1	VERIFY	Check the CPDLC dialogue appears as closed on ground display systems.
Comments: Depending on implementation it is mandatory to either conduct testcase ACL_004 or ACL_005.			

<b>Name:</b>	Dialogue type: 'level', controller initiated		
<b>Identifier</b>	ACL_006		
<b>Purpose:</b>	The purpose of the test is to check the Ground System correctly handles a 'level' type dialogue. This ACL dialogue is initiated by ground side.		
<b>Preamble:</b>	It is assumed AIRCRAFT1 is already logged and CPDLC connected to GND1.		
<b>Steps:</b>			
<b>No</b>	<b>System</b>	<b>Action</b>	<b>Description</b>
1	GND1	ENTER	Send the UM19 MAINTAIN [level] message to AIRCRAFT1.
2	AIRCRAFT1	VERIFY	Check AIRCRAFT1 receives the UM19 MAINTAIN [level] message from GND1.
3	AIRCRAFT1	ENTER	Send DM100 LACK message to acknowledge UM19 MAINTAIN [level] message.
4	GND1	VERIFY	Check GND1 receives the DM100 LACK message acknowledging the UM19 MAINTAIN [level] message.
5	AIRCRAFT1	ENTER	Send the DM1 UNABLE message in response to UM19 MAINTAIN [level] message.
6	GND1	VERIFY	Check GND1 receives the DM1 UNABLE message in response to UM19 MAINTAIN [level] message.
7	GND1	ENTER	Send UM227 LACK message to acknowledge DM1 UNABLE message.
8	AIRCRAFT1	VERIFY	Check AIRCRAFT1 receives the UM227 LACK message acknowledging the DM1 UNABLE message.
9	GND1	VERIFY	Check the 'level' type dialogue is closed.

<b>Name:</b>	Dialogue type: 'route', controller initiated		
<b>Identifier</b>	ACL_007		
<b>Purpose:</b>	The purpose of the test is to check the Ground System correctly handles a 'route' type dialogue. This ACL dialogue is initiated by ground side.		
<b>Preamble:</b>	It is assumed AIRCRAFT1 is already logged and CPDLC connected to GND1.		
<b>Steps:</b>			
<b>No</b>	<b>System</b>	<b>Action</b>	<b>Description</b>
1	GND1	ENTER	Send the UM74 PROCEED DIRECT TO [position] message to AIRCRAFT1.
2	AIRCRAFT1	VERIFY	Check AIRCRAFT1 receives the UM74 PROCEED DIRECT TO [position] message from GND1.
3	AIRCRAFT1	ENTER	Send DM100 LACK message to acknowledge the UM74 PROCEED DIRECT TO [position] message.
4	GND1	VERIFY	Check GND1 receives the DM100 LACK message acknowledging the UM74 PROCEED DIRECT TO [position] message.
5	AIRCRAFT1	ENTER	Send the DM2 STANDBY message in response to UM74 PROCEED DIRECT TO [position] message.
6	GND1	VERIFY	Check GND1 receives the DM2 STANDBY message in response to UM74 PROCEED DIRECT TO [position] message.
7	GND1	ENTER	Send UM227 LACK message to acknowledge DM2 STANDBY message.
8	AIRCRAFT1	VERIFY	Check AIRCRAFT1 receives the UM227 LACK message acknowledging the DM2 STANDBY message.
9	AIRCRAFT1	ENTER	Send the DM1 UNABLE message in response to UM74 PROCEED DIRECT TO [position] message.
10	GND1	VERIFY	Check GND1 receives the DM1 UNABLE message in response to UM74 PROCEED DIRECT TO [position] message.
11	GND1	ENTER	Send UM227 LACK message to acknowledge DM1 UNABLE message.
12	AIRCRAFT1	VERIFY	Check AIRCRAFT1 receives the UM227 LACK message acknowledging the DM1 UNABLE message.
13	GND1	VERIFY	Check the 'route' type dialogue is closed.

<b>Name:</b>	Dialogue type: 'heading', controller initiated		
<b>Identifier</b>	ACL_008		
<b>Purpose:</b>	The purpose of the test is to check the Ground System correctly handles a 'heading' type dialogue. This ACL dialogue is initiated by ground side.		
<b>Preamble:</b>	It is assumed AIRCRAFT1 is already logged and CPDLC connected to GND1.		
<b>Steps:</b>			
<b>No</b>	<b>System</b>	<b>Action</b>	<b>Description</b>
1	GND1	ENTER	Send the UM190 FLY HEADING [degrees] to AIRCRAFT1.
2	AIRCRAFT1	VERIFY	Check AIRCRAFT1 receives the UM190 FLY HEADING [degrees] message from GND1.
3	AIRCRAFT1	ENTER	Send DM100 LACK message to acknowledge the UM190 FLY HEADING [degrees] message.
4	GND1	VERIFY	Check GND1 receives the DM100 LACK message acknowledging the UM190 FLY HEADING [degrees] message.
5	AIRCRAFT1	ENTER	Send the DM1 UNABLE + DM66 DUE TO AIRCRAFT PERFORMANCE message in response to UM190 FLY HEADING [degrees] message.
6	GND1	VERIFY	Check GND1 receives the DM1 UNABLE + DM66 DUE TO AIRCRAFT PERFORMANCE message in response to UM190 FLY HEADING [degrees] message.
7	GND1	ENTER	Send UM227 LACK message to acknowledge DM1 UNABLE + DM66 DUE TO AIRCRAFT PERFORMANCE message.
8	AIRCRAFT1	VERIFY	Check AIRCRAFT1 receives the UM227 LACK message acknowledging the DM1 UNABLE + DM66 DUE TO AIRCRAFT PERFORMANCE message.
9	GND1	VERIFY	Check the 'heading' type dialogue is closed.

### 5.3.4 AMC Service

According to ED110B implementation of AMC service can use either UM183 or UM157. Depending on implementation either testcase AMC\_001 or AMC\_002 shall be conducted.

<b>Name:</b>	AMC Service using UM157		
<b>Identifier</b>	AMC_001		
<b>Purpose:</b>	The goal of this test is to check that the Ground system is able to broadcast the ATC Microphone Check message to all aircrafts in charge. This test is performed with two aircrafts.		
<b>Preamble:</b>	It is assumed that AIRCRAFT1 and AIRCRAFT2 are already logged and CPDLC connected to Ground System.		
<b>Steps:</b>			
<b>No</b>	<b>System</b>	<b>Action</b>	<b>Description</b>
1	GND1	ENTER	Send the UM157 Check Stuck Microphone [frequency] to all aircrafts in charge.
2	AIRCRAFT1	VERIFY	Check AIRCRAFT1 receives the UM157 CHECK STUCK MICROPHONE [frequency] message.
3	AIRCRAFT2	VERIFY	Check AIRCRAFT2 receives the UM157 CHECK STUCK MICROPHONE [frequency] message.
4	AIRCRAFT1	ENTER	Send the DM100 LACK message to acknowledge the UM157 CHECK STUCK MICROPHONE [frequency] message.
5	AIRCRAFT2	ENTER	Send the DM100 LACK message to acknowledge the UM157 CHECK STUCK MICROPHONE [frequency] message.
6	GND1	VERIFY	Check ground system receives 2 DM100 LACK acknowledging the uplink messages.
7	GND1	VERIFY	Check all UM157 dialogues appear as closed on ground display systems.
<b>Comments:</b>	Some implementations do not require LACK when sending the UM157 CHECK STUCK MICROPHONE [frequency] message. In this case, steps #4 to #6 are not executed.		

<b>Name:</b>	AMC Service using UM183		
<b>Identifier</b>	AMC_002		
<b>Purpose:</b>	The goal of this test is to check that the Ground system is able to broadcast the ATC Microphone Check message to all aircrafts in charge. This test is performed with two aircrafts.		
<b>Preamble:</b>	It is assumed that AIRCRAFT1 and AIRCRAFT2 are already logged and CPDLC connected to Ground System.		
<b>Steps:</b>			
<b>No</b>	<b>System</b>	<b>Action</b>	<b>Description</b>
1	GND1	ENTER	Send the UM183 [CHECK STUCK MICROPHONE] to all aircrafts in charge.
2	AIRCRAFT1	VERIFY	Check AIRCRAFT1 receives the UM183 [CHECK STUCK MICROPHONE] message.
3	AIRCRAFT2	VERIFY	Check AIRCRAFT2 receives the UM183 [CHECK STUCK MICROPHONE] message.
4	AIRCRAFT1	ENTER	Send the DM100 LACK message to acknowledge the UM183 [CHECK STUCK MICROPHONE] message.
5	AIRCRAFT2	ENTER	Send the DM100 LACK message to acknowledge the UM183 [CHECK STUCK MICROPHONE] message.
6	GND1	VERIFY	Check ground system receives 2 DM100 LACK acknowledging the uplink messages.
7	GND1	VERIFY	Check all UM183 dialogues appear as closed on ground display systems.
<b>Comments:</b> Some implementations do not require LACK when sending the UM183 [CHECK STUCK MICROPHONE] message. In this case, steps #4 to #6 are not executed.			

### 5.3.5 ACM Service

The following tests shall be performed.

<b>Name:</b>	Internal transfer: nominal case		
<b>Identifier</b>	ACM_001		
<b>Purpose:</b>	The goal of this test is to perform an internal transfer of frequency (from T-Sector to R-Sector).		
<b>Preamble:</b>	It is assumed AIRCRAFT1 is logged and CPDLC connected to the Ground System.		
<b>Steps:</b>			
<b>No</b>	<b>System</b>	<b>Action</b>	<b>Description</b>
1	GND1 (T-sector)	ENTER	Send UM117 CONTACT [unitName][frequency] to AIRCRAFT1 to identify the next sector for control.
2	AIRCRAFT	VERIFY	Check AIRCRAFT1 receives the transfer instruction message identifying the next sector for control.
3	AIRCRAFT1	ENTER	Send the DM100 LACK message to acknowledge the transfer instruction message.
4	GND1 (T-sector)	VERIFY	Check GND1 receives the DM100 LACK message acknowledging the transfer instruction message.
5	AIRCRAFT1	ENTER	Send the DM0 WILCO in response to the transfer instruction message.
6	GND1 (T-Sector)	VERIFY	Check GND1 receives the DM0 WILCO message in response to the transfer instruction message.
7	GND1 (T-Sector)	ENTER	Send the UM227 LACK message to acknowledge the DM0 WILCO message.
8	AIRCRAFT1	VERIFY	Check AIRCRAFT1 receives the UM227 LACK acknowledging the DM0 WILCO message.
9	GND1	VERIFY	Check all CPDLC dialogues with GND1 appear as closed for AIRCRAFT1.

<b>Name:</b>	External transfer: nominal case		
<b>Identifier</b>	ACM_002		
<b>Purpose:</b>	The goal of this test is to perform a transfer of frequency from T-ATSU to R-ATSU. The System Under Test (Ground System) is the T-ATSU.		
<b>Preamble:</b>	It is assumed AIRCRAFT1 is logged and CPDLC connected to the Ground System. It is assumed the logon transfer has already been processed for AIRCRAFT1.		
<b>Steps:</b>			
<b>No</b>	<b>System</b>	<b>Action</b>	<b>Description</b>
1	GND1	ENTER	Send the UM160 NEXT DATA AUTHORITY message to AIRCRAFT1, identifying the next facility (R-ATSU).
2	AIRCRAFT1	VERIFY	Check AIRCRAFT1 receives the UM160 NEXT DATA AUTHORITY message identifying the next facility centre.
3	AIRCRAFT1	ENTER	Send the DM100 LACK message to acknowledge the UM160 NEXT DATA AUTHORITY message.
4	GND1	VERIFY	Check GND1 receives the DM100 LACK message acknowledging the UM160 NEXT DATA AUTHORITY message.
5	GND1	ENTER	Send the CPDLC-end request containing UM117 CONTACT [unitName] [frequency] message.
6	AIRCRAFT1	VERIFY	Check AIRCRAFT1 receives the CPDLC-end indication providing the transfer instruction message element.
7	AIRCRAFT1	ENTER	Send the DM100 LACK message to acknowledge the transfer instruction message element.
8	GND1	VERIFY	Check GND1 receives the DM100 LACK message acknowledging the transfer instruction message element.
9	AIRCRAFT1	ENTER	Send the accepted CPDLC-end response providing the DM0 WILCO message element to GND1.
10	GND1	VERIFY	Check the GND1 receives the accepted CPDLC-end confirmation providing the DM0 WILCO message element. Check it is not possible to send uplink message to AIRCRAFT1.
11	GND1	VERIFY	Check the CPDLC connection between GND1 and AIRCRAFT1 is closed.

<b>Name:</b>	External transfers with air initiated pending dialogs		
<b>Identifier</b>	ACM_003		
<b>Purpose:</b>	The goal of this test is to check that Ground System correctly handles an external frequency transfer with a pending air initiated dialog.		
<b>Preamble:</b>	It is assumed AIRCRAFT1 is logged and CPDLC connected to the Ground System. It is assumed the logon transfer has already been processed for AIRCRAFT1.		
<b>Steps:</b>			
<b>No</b>	<b>System</b>	<b>Action</b>	<b>Description</b>
1	GND1	ENTER	Send the UM160 NEXT DATA AUTHORITY message to AIRCRAFT1, identifying the next facility (R-ATSU).
2	AIRCRAFT1	VERIFY	Check AIRCRAFT1 receives the UM160 NEXT DATA AUTHORITY message identifying the next facility centre.
3	AIRCRAFT1	ENTER	Send the DM100 LACK message to acknowledge the UM160 NEXT DATA AUTHORITY message.
4	GND1	VERIFY	Check GND1 receives the DM100 LACK message acknowledging the UM160 NEXT DATA AUTHORITY message.
5	AIRCRAFT1	ENTER	Send the DM9 REQUEST CLIMB TO [level] message to GND1.
6	GND1	VERIFY	Check GND1 receives the DM9 REQUEST CLIMB TO [level] message.
7	GND1	ENTER	Transfer to next ATSU is started according to local procedures.
8a	GND1	ENTER	Send the concatenation of message element UM159 ERROR [errorInformation] with the choice (2) followed by message element UM183 'REQUEST AGAIN WITH NEXT UNIT' in response to the DM9 REQUEST CLIMB TO [level] message.
8b	GND1	ENTER	Send the UM0 UNABLE message in response to the DM9 REQUEST CLIMB TO [level] message.
8c	GND1	ENTER	Send the UM237 [REQUEST AGAIN WITH NEXT UNIT] message in response to the DM9 REQUEST CLIMB TO [level] message.
9a	AIRCRAFT1	VERIFY	Check AIRCRAFT1 receives the UM159 ERROR [errorInformation] with the choice (2) followed by message element UM183 'REQUEST AGAIN WITH NEXT UNIT' in response to the DM9 REQUEST CLIMB TO [level] message.
9b	AIRCRAFT1	VERIFY	Check AIRCRAFT1 receives the UM0 UNABLE in response to the DM9 REQUEST CLIMB TO [level] message.
9c	AIRCRAFT1	VERIFY	Check AIRCRAFT1 receives the UM183 [REQUEST AGAIN WITH NEXT UNIT] in response to the DM9 REQUEST CLIMB TO [level] message.
10	GND1	ENTER	Send the CPDLC-end request containing UM117 CONTACT [unitName] [frequency] message.
11	AIRCRAFT1	VERIFY	Check AIRCRAFT1 receives the CPDLC-end indication providing the message of transfer instruction.
12	AIRCRAFT1	ENTER	Send the DM100 LACK message to acknowledge the message of transfer instruction.
13	GND1	VERIFY	Check GND1 receives the DM100 LACK message acknowledging the message of transfer instruction.
14	AIRCRAFT1	ENTER	Send the accepted CPDLC-end response providing the DM0 WILCO message element to GND1.
15	GND1	VERIFY	Check the GND1 receives the accepted CPDLC-end confirmation providing the DM0 WILCO message element.
16	GND1	VERIFY	Check no more CPDLC connection exists between GND1 and AIRCRAFT1
<p>Comments: As there is an air initiated pending dialog, it must be closed before performing the frequency transfer action. ED-110B provides 4 ways to resolve the pending dialogue:</p> <ul style="list-style-type: none"> <li>- the message element UM0 UNABLE; or</li> <li>- the message element UM237 REQUEST AGAIN WITH NEXT UNIT; or</li> <li>- the message element UM183 'REQUEST AGAIN WITH NEXT UNIT'; or</li> <li>- the concatenation UM159+UM183 as described in the test.</li> </ul> <p>According to implementation either steps 8a/9a, 8b/9b or 8c/9c shall be conducted. Please note that UM237 REQUEST AGAIN WITH NEXT UNIT is not part of the mandatory message set and therefore no teststeps are provided for this option.</p>			

<b>Name:</b>		External transfers refused	
<b>Identifier</b>		ACM_004	
<b>Purpose:</b>		<p>The goal of this test is to test that Ground System correctly handles an external frequency transfer procedure that is refused by aircrew. It also demonstrates that ACL dialogue is still possible after the frequency transfer failure.</p> <p>The System Under Test (Ground System) is the T-ATSU.</p>	
<b>Preamble:</b>		<p>It is assumed AIRCRAFT1 is logged and CPDLC connected to the Ground System.</p> <p>It is assumed the logon transfer has already been processed for AIRCRAFT1.</p>	
<b>Steps:</b>			
No	System	Action	Description
1	GND1	ENTER	Send the UM160 NEXT DATA AUTHORITY message to AIRCRAFT1, identifying the next facility (R-ATSU).
2	AIRCRAFT1	VERIFY	Check AIRCRAFT1 receives the UM160 NEXT DATA AUTHORITY message identifying the next facility centre.
3	AIRCRAFT1	ENTER	Send the DM100 LACK message to acknowledge the UM160 NEXT DATA AUTHORITY message.
4	GND1	VERIFY	Check GND1 receives the DM100 LACK message acknowledging the UM160 NEXT DATA AUTHORITY message.
5	GND1	ENTER	Send the CPDLC-end request containing UM117 CONTACT [unitName] [frequency] message.
6	AIRCRAFT1	VERIFY	Check AIRCRAFT1 receives the CPDLC-end indication providing the transfer instruction message element.
7	AIRCRAFT1	ENTER	Send the DM100 LACK message to acknowledge the message of transfer instruction.
8	GND1	VERIFY	Check GND1 receives the DM100 LACK message acknowledging the message of transfer instruction.
9	AIRCRAFT1	ENTER	Send the rejected CPDLC-end response providing the DM1 UNABLE message element to GND1.
10	GND1	VERIFY	Check the GND1 receives the rejected CPDLC-end confirmation providing the DM1 UNABLE message element.
11	GND1	ENTER	Send the UM20 CLIMB TO [level] to AIRCRAFT1.
12	AIRCRAFT1	VERIFY	Check AIRCRAFT1 receives the UM20 CLIMB TO [level] message.
13	AIRCRAFT1	ENTER	Send the DM100 LACK message to acknowledge the UM20 CLIMB TO [level] message.
14	GND1	VERIFY	Check GND1 receives the DM100 LACK acknowledging the UM20 CLIMB TO [level] message.
15	AIRCRAFT1	ENTER	Send the DM0 WILCO message is response to UM20 CLIMB TO [level] message.
16	GND1	VERIFY	Check GND1 receives the DM0 WILCO message in response to UM20 CLIMB TO [level] message.
17	GND1	ENTER	Send the UM227 LACK message to acknowledge the DM0 WILCO message.
18	AIRCRAFT1	VERIFY	Check AIRCRAFT1 receives the UM227 LACK message acknowledging the DM0 WILCO message.
19	AIRCRAFT1	VERIFY	Check the 'level' type dialogue appears as closed on ground display systems.
20	AIRCRAFT1	VERIFY	Check AIRCRAFT1 is still connected to GND1.



<b>Name:</b>	External transfer with ttr timer expiry		
<b>Identifier</b>	ACM_005		
<b>Purpose:</b>	<p>The goal of this test is to test that Ground System correctly handles an external frequency transfer procedure that fails because of air <i>ttr</i> timer expiry. It also demonstrates that ACL dialogue is still possible after the frequency transfer failure.</p> <p>The System Under Test (Ground System) is the T-ATSU.</p>		
<b>Preamble:</b>	<p>It is assumed AIRCRAFT1 is logged and CPDLC connected to the Ground System.</p> <p>It is assumed the logon transfer has already been processed for AIRCRAFT1.</p>		
<b>Steps:</b>			
<b>No</b>	<b>System</b>	<b>Action</b>	<b>Description</b>
1	GND1	ENTER	Send the UM160 NEXT DATA AUTHORITY message to AIRCRAFT1, identifying the next facility (R-ATSU).
2	AIRCRAFT1	VERIFY	Check AIRCRAFT1 receives the UM160 NEXT DATA AUTHORITY message identifying the next facility centre.
3	AIRCRAFT1	ENTER	Send the DM100 LACK message to acknowledge the UM160 NEXT DATA AUTHORITY message.
4	GND1	VERIFY	Check GND1 receives the DM100 LACK message acknowledging the UM160 NEXT DATA AUTHORITY message.
5	GND1	ENTER	Send the CPDLC-end request containing UM117 CONTACT [unitName] [frequency] message.
6	AIRCRAFT1	VERIFY	Check AIRCRAFT1 receives the CPDLC-end indication providing the transfer instruction message element.
7	AIRCRAFT1	ENTER	Send the DM100 LACK message to acknowledge the message of transfer instruction.
8	GND1	VERIFY	Check GND1 receives the DM100 LACK message acknowledging the message of transfer instruction.
9	AIRCRAFT1	WAIT	Wait for expiry of air <i>ttr</i> timer.
10	AIRCRAFT1	VERIFY	Check AIRCRAFT1 sends a rejected CPDLC-End response providing a CPDLC downlink message containing the concatenation of message elements DM62 (ERROR (2)) plus DM98 (AIR SYSTEM TIMEOUT). Check the dialogue is closed.
12	GND1	VERIFY	Check GND1 receives the rejected CPDLC-End confirmation providing the concatenation of DM62 (ERROR (2)) plus the DM98 (AIR SYSTEM TIMEOUT). Check the dialogue is closed.
13	GND1	ENTER	Send the UM20 CLIMB TO [level] to AIRCRAFT1.
14	AIRCRAFT1	VERIFY	Check AIRCRAFT1 receives the UM20 CLIMB TO [level] message.
15	AIRCRAFT1	ENTER	Send the DM100 LACK to acknowledge the UM20 CLIMB TO [level] message.
16	GND1	VERIFY	Check GND1 receives the DM100 LACK acknowledging UM20 CLIMB TO [level] message.
17	AIRCRAFT1	ENTER	Send the DM0 WILCO in response to UM20 CLIMB TO [level] message.
18	GND1	VERIFY	Check GND1 receives the DM0 WILCO in response to UM20 CLIMB TO [level] message.
19	GND1	ENTER	Send the UM227 LACK to acknowledge the DM0 WILCO message.
20	AIRCRAFT1	VERIFY	Check AIRCRAFT1 receives the UM227 LACK acknowledging the DM0 WILCO message.
21	GND1	VERIFY	Check the 'level' type dialogue appears as closed on ground display systems.
22	GND1	VERIFY	Check AIRCRAFT1 is still CPDLC connected to GND1.

<b>Name:</b>	External transfer with change of NDA (datalink equipped)		
<b>Identifier</b>	ACM_006		
<b>Purpose:</b>	The goal of this test is the Ground System behaviour when the next centre changes before an external transfer. In this test, the next centre is datalink equipped.		
<b>Preamble:</b>	It is assumed AIRCRAFT1 is logged and CPDLC connected to the Ground System. It is assumed the logon transfer has already been processed for AIRCRAFT1.		
<b>Steps:</b>			
<b>No</b>	<b>System</b>	<b>Action</b>	<b>Description</b>
1	GND1	ENTER	Send the UM160 NEXT DATA AUTHORITY message to AIRCRAFT1, identifying the next facility (R-ATSU1).
2	AIRCRAFT1	VERIFY	Check AIRCRAFT1 receives the UM160 NEXT DATA AUTHORITY message identifying the next facility centre.
3	AIRCRAFT1	ENTER	Send the DM100 LACK message to acknowledge the UM160 NEXT DATA AUTHORITY message.
4	GND1	VERIFY	Check GND1 receives the DM100 LACK message acknowledging the UM160 NEXT DATA AUTHORITY message.
5	GND1	ENTER	Send a new UM160 NEXT DATA AUTHORITY message to AIRCRAFT1, identifying the new next facility (R-ATSU2).
6	AIRCRAFT1	VERIFY	Check AIRCRAFT1 receives the new UM160 NEXT DATA AUTHORITY message identifying the new next facility centre.
7	AIRCRAFT1	ENTER	Send the DM100 LACK message to acknowledge the UM160 NEXT DATA AUTHORITY message.
8	GND1	VERIFY	Check GND1 receives the DM100 LACK message acknowledging the UM160 NEXT DATA AUTHORITY message.
9	GND1	ENTER	Send the CPDLC-end request containing UM117 CONTACT [unitName] [frequency] message.
10	AIRCRAFT1	VERIFY	Check AIRCRAFT1 receives the CPDLC-end indication providing the transfer instruction message element.
11	AIRCRAFT1	ENTER	Send the DM100 LACK message to acknowledge the message of transfer instruction.
12	GND1	VERIFY	Check GND1 receives the DM100 LACK message acknowledging the message of transfer instruction.
13	AIRCRAFT1	ENTER	Send the accepted CPDLC-end response providing the DM0 WILCO message element to GND1.
14	GND1	VERIFY	Check the GND1 receives the accepted CPDLC-end confirmation providing the DM0 WILCO message element.
15	GND1	VERIFY	Check AIRCRAFT1 is no more connected to GND1.

<b>Name:</b>	External transfer with change of NDA (not datalink equipped)		
<b>Identifier</b>	ACM_007		
<b>Purpose:</b>	The goal of this test is to check the Ground System behaviour when the next centre changes before an external transfer. In this test, the next centre is not datalink equipped (or is not using datalink).		
<b>Preamble:</b>	It is assumed AIRCRAFT1 is logged and CPDLC connected to the Ground System. In this test, the former next centre is a data link one.		
<b>Steps:</b>			
<b>No</b>	<b>System</b>	<b>Action</b>	<b>Description</b>
1	GND1	ENTER	Send the UM160 NEXT DATA AUTHORITY message to AIRCRAFT1, identifying the next facility (R-ATSU1).
2	AIRCRAFT1	VERIFY	Check AIRCRAFT1 receives the UM160 NEXT DATA AUTHORITY message identifying the next facility centre.
3	AIRCRAFT1	ENTER	Send the DM100 LACK message to acknowledge the UM160 NEXT DATA AUTHORITY message.
4	GND1	VERIFY	Check GND1 receives the DM100 LACK message acknowledging the UM160 NEXT DATA AUTHORITY message.
5	GND1	ENTER	Send a new UM160 NEXT DATA AUTHORITY message to AIRCRAFT1, identifying the new next facility (R-ATSU2). As this next centre is not datalink equipped (or is not using datalink), the UM160 NEXT DATA AUTHORITY is filled in with the choice [noFacility] to cancel the NDA indications.
6	AIRCRAFT1	VERIFY	Check AIRCRAFT1 receives the new UM160 NEXT DATA AUTHORITY message cancelling the NDA indications.
7	AIRCRAFT1	ENTER	Send the DM100 LACK message to acknowledge the UM160 NEXT DATA AUTHORITY message.
8	GND1	VERIFY	Check GND1 receives the DM100 LACK message acknowledging the UM160 NEXT DATA AUTHORITY message.
9	GND1	ENTER	Send the CPDLC-end request containing UM117 CONTACT [unitName] [frequency] message.
10	AIRCRAFT1	VERIFY	Check AIRCRAFT1 receives the CPDLC-end indication providing the message of transfer instruction.
11	AIRCRAFT1	ENTER	Send the DM100 LACK message to acknowledge the message of transfer instruction.
12	GND1	VERIFY	Check GND1 receives the DM100 LACK message to acknowledge the message of transfer instruction.
13	AIRCRAFT1	ENTER	Send the accepted CPDLC-end response providing the DM0 WILCO message element to GND1.
14	GND1	VERIFY	Check the GND1 receives the accepted CPDLC-end confirmation providing the DM0 WILCO message element.
15	GND1	VERIFY	Check AIRCRAFT1 is no more CPDLC connected to GND1.

## 5.4 Test with real aircraft

The following test shall be performed with a real aircraft certified for DLS-operations in accordance with Regulation 1702/2003 [14] connected via a real VDL Mode 2 environment.

<b>Name:</b>		End to end test with real aircraft	
<b>Identifier</b>		EE_001	
<b>Purpose:</b>		The purpose of the test is to check the Ground System correctly interacts with a real aircraft avionic system.	
<b>Preamble:</b>		It is assumed that AIRCRAFT1 is authorized to logon to GND1. As required by ED-110B, the logon request shall provide the optional ADEP and ADES fields.	
<b>Steps:</b>			
No	System	Action	Description
1	AIRCRAFT1	ENTER	AIRCRAFT1 sends a CM-logon request to GND1.
2	GND1	VERIFY	Check GND1 receives the CM-logon indication from AIRCRAFT1.
3	GND1	ENTER	GND1 responds with a positive CM-logon response to AIRCRAFT1.
4	AIRCRAFT1	VERIFY	Check AIRCRAFT1 receives an accepted CM-logon confirmation message providing supported applications by GND1.
5	GND1	VERIFY	Check on ground side that AIRCRAFT1 appears logged on GND1.
6	GND1	ENTER	Send a CPDLC-start request to AIRCRAFT1 (no CPDLC message element provided).
7	AIRCRAFT1	VERIFY	Check AIRCRAFT1 receives the CPDLC-start indication (no CPDLC message element provided) from GND1.
8	AIRCRAFT1	ENTER	Send an accepted CPDLC-start response to GND1.
9	GND1	VERIFY	Check GND1 receives the accepted CPDLC-start confirmation from AIRCRAFT1.
10	AIRCRAFT1	ENTER	Send the DM99 CURRENT DATA AUTHORITY message to GND1.
11	GND1	VERIFY	Check GND1 receives the DM99 CURRENT DATA AUTHORITY message from AIRCRAFT1.
12	GND1	ENTER	Send the UM227 LACK message to AIRCRAFT1 to acknowledge DM99 CURRENT DATA AUTHORITY message.
13	AIRCRAFT1	VERIFY	Check AIRCRAFT1 receives the UM227 LACK message from GND1 acknowledging the DM99 CURRENT DATA AUTHORITY message.
14	GND1	ENTER	Send the UM183 'CURRENT ATC UNIT facility designation, facility name, facility function' message to AIRCRAFT1.
15	AIRCRAFT1	VERIFY	Check AIRCRAFT1 receives the UM183 'CURRENT ATC UNIT facility designation, facility name, facility function' message.
16	AIRCRAFT1	ENTER	Send the DM100 LACK message to acknowledge the UM183 'CURRENT ATC UNIT facility designation, facility name, facility function' message.
17	GND1	VERIFY	Check GND1 receives the DM100 LACK message acknowledging the UM183 'CURRENT ATC UNIT facility designation, facility name, facility function' message.
18	GND1	VERIFY	Check AIRCRAFT1 appears as logged on and CPDLC connected to GND1.
19	AIRCRAFT1	ENTER	Send the DM6 REQUEST [level] message to GND1.
20	GND1	VERIFY	Check GND1 receives the DM6 REQUEST [level] message from AIRCRAFT1.
21	GND1	ENTER	Send UM227 LACK message to acknowledge DM6 REQUEST [level] message.
22	AIRCRAFT1	VERIFY	Check AIRCRAFT1 receives the UM227 LACK message, acknowledging DM6 REQUEST [level] message.
23	GND1	ENTER	Send UM20 CLIMB TO [level] to AIRCRAFT1 in response to DM6 REQUEST [level] message.
24	AIRCRAFT	VERIFY	Check AIRCRAFT1 receives UM20 CLIMB TO [level] in response to DM6 REQUEST [level] message.
25	AIRCRAFT1	ENTER	Send DM100 LACK message to acknowledge UM20 CLIMB TO [level] message.
26	GND1	VERIFY	Check GND1 receives DM100 LACK message, acknowledging UM20 CLIMB TO [level] message.
27	AIRCRAFT1	ENTER	Send DM0 WILCO message in response to UM20 CLIMB TO [level] message.
28	GND1	VERIFY	Check GND1 receives DM0 WILCO message in response to UM20 CLIMB TO [level] message.
29	GND1	ENTER	Send UM227 LACK message to acknowledge the DM0 WILCO message.

<b>Name:</b>	End to end test with real aircraft		
<b>Identifier</b>	EE_001		
<b>Purpose:</b>	The purpose of the test is to check the Ground System correctly interacts with a real aircraft avionic system.		
<b>Preamble:</b>	It is assumed that AIRCRAFT1 is authorized to logon to GND1. As required by ED-110B, the logon request shall provide the optional ADEP and ADES fields.		
<b>Steps:</b>			
<b>No</b>	<b>System</b>	<b>Action</b>	<b>Description</b>
30	AIRCRAFT1	VERIFY	Check AIRCRAFT1 receives the UM227 LACK message, acknowledging the DM0 WILCO message.
31	GND1	VERIFY	Check this 'level' type dialogue appears as closed on ground display systems.
32	GND1	ENTER	Send the UM74 PROCEED DIRECT TO [position] message to AIRCRAFT1.
33	AIRCRAFT1	VERIFY	Check AIRCRAFT1 receives the UM74 PROCEED DIRECT TO [position] message from GND1.
34	AIRCRAFT1	ENTER	Send DM100 LACK message to acknowledge the UM74 PROCEED DIRECT TO [position] message.
35	GND1	VERIFY	Check GND1 receives the DM100 LACK message acknowledging the UM74 PROCEED DIRECT TO [position] message.
36	AIRCRAFT1	ENTER	Send the DM2 STANDBY message in response to UM74 PROCEED DIRECT TO [position] message.
37	GND1	VERIFY	Check GND1 receives the DM2 STANDBY message in response to UM74 PROCEED DIRECT TO [position] message.
38	GND1	ENTER	Send UM227 LACK message to acknowledge DM2 STANDBY message.
39	AIRCRAFT1	VERIFY	Check AIRCRAFT1 receives the UM227 LACK message acknowledging the DM2 STANDBY message.
40	AIRCRAFT1	ENTER	Send the DM1 UNABLE message in response to UM74 PROCEED DIRECT TO [position] message.
41	GND1	VERIFY	Check GND1 receives the DM1 UNABLE message in response to UM74 PROCEED DIRECT TO [position] message.
42	GND1	ENTER	Send UM227 LACK message to acknowledge DM1 UNABLE message.
43	AIRCRAFT1	VERIFY	Check AIRCRAFT1 receives the UM227 LACK message acknowledging the DM1 UNABLE message.
44	GND1	VERIFY	Check the 'route' type dialogue is closed.
<b>Comments:</b> It is assumed that required local conditions (ASSUME input, etc.) are met to consider CPDLC enabled. Some implementations do not require a LACK to the UM183 in step 14.			

## 6 Conformity Assessment materials

### 6.1 Eurocontrol DLS Specification, clause A.3.1.1

Tables 16 and 17 shall be completed to show conformance to the present document.

**Table 15: Uplink message elements- Ground User**

Operational Elements		Requirement	Implementation
UM0	UNABLE	U	
UM1	STANDBY	U	
UM3	ROGER	C	
UM4	AFFIRM	C	
UM5	NEGATIVE	C	
UM19	MAINTAIN [level]	U	
UM20	CLIMB TO [level]	U	
UM23	DESCEND TO [level]	U	
UM26	CLIMB TO REACH [level] BY [time]	C	
UM27	CLIMB TO REACH [level] BY [position]	C	
UM28	DESCEND TO REACH [level] BY [time]	C	
UM29	DESCEND TO REACH [level] BY [position]	C	
UM46	CROSS [position] AT [level]	C	
UM47	CROSS [position] AT OR ABOVE [level]	C	
UM48	CROSS [position] AT OR BELOW [level]	C	
UM51	CROSS [position] AT [time]	C	
UM52	CROSS [position] AT OR BEFORE [time]	C	
UM53	CROSS [position] AT OR AFTER [time]	C	
UM54	CROSS [position] BETWEEN [time] AND [time]	C	
UM55	CROSS [position] AT [speed]	C	
UM61	CROSS [position] AT AND MAINTAIN [level] AT [speed]	C	
UM64	OFFSET [specifiedDistance] [direction] OF ROUTE	C	
UM72	RESUME OWN NAVIGATION	C	
UM74	PROCEED DIRECT TO [position]	U	
UM79	CLEARED TO [position] VIA [routeClearance]	C	
UM80	CLEARED [route clearance]	C	
UM82	CLEARED TO DEVIATE UP TO [specifiedDistance] [direction] OF ROUTE	C	
UM92	HOLD AT [position] AS PUBLISHED MAINTAIN [level]	C	
UM94	TURN [direction] HEADING [degrees]	C	
UM96	CONTINUE PRESENT HEADING	C	
UM106	MAINTAIN [speed]	C	
UM107	MAINTAIN PRESENT SPEED	C	
UM108	MAINTAIN [speed] OR GREATER	C	
UM109	MAINTAIN [speed] OR LESS	C	
UM116	RESUME NORMAL SPEED	C	
UM117	CONTACT [unitname] [frequency]	U	
UM120	MONITOR [unitname] [frequency]	C	
UM123	SQUAWK [code]	C	
UM133	REPORT PRESENT LEVEL	C	
UM148	WHEN CAN YOU ACCEPT [level]	C	
UM157	CHECK STUCK MICROPHONE [frequency]	C	
UM159	ERROR [errorInformation]	U	
UM160	NEXT DATA AUTHORITY [facility]	U	
UM162	SERVICE UNAVAILABLE	U	
UM165	THEN	C	
UM171	CLIMB AT [verticalRate] MINIMUM	C	
UM172	CLIMB AT [verticalRate] MAXIMUM	C	
UM173	DESCEND AT [verticalRate] MINIMUM	C	
UM174	DESCEND AT [verticalRate] MAXIMUM	C	
UM179	SQUAWK IDENT	C	
UM183	[freetext]	U	
UM190	FLY HEADING [degrees]	U	
UM196	[freetext]	C	
UM203	[freetext]	C	
UM205	[freetext]	C	
UM211	REQUEST FORWARDED	C	
UM213	[facilitydesignation] ALTIMETER [altimeter]	C	
UM215	TURN [direction] [degrees]	C	
UM222	NO SPEED RESTRICTION	C	
UM227	LOGICAL ACKNOWLEDGMENT	U	

Operational Elements	Requirement	Implementation
UM231 STATE PREFERRED LEVEL	C	
UM232 STATE-TOP-OF-DESCENT	C	
UM237 REQUEST AGAIN WITH NEXT UNIT	C	
NOTE: "U" stands for "unconditional" means that it has to be supported. "C" stands for "conditional" means that it has to be supported under certain conditions.		

Table 16: Downlink message elements- Ground User

Operational Elements	Requirement	Implementation
DM0 WILCO	U	
DM1 UNABLE	U	
DM2 STANDBY	U	
DM3 ROGER	C	
DM4 AFFIRM	C	
DM5 NEGATIVE	C	
DM6 REQUEST [level]	U	
DM9 REQUEST CLIMB TO [level]	U	
DM10 REQUEST DESCENT TO [level]	U	
DM18 REQUEST [speed]	C	
DM22 REQUEST DIRECT TO [position]	U	
DM27 REQUEST WEATHER DEVIATION UP TO [specifiedDistance] [direction] OF ROUTE	C	
DM32 PRESENT LEVEL [level]	C	
DM62 ERROR [errorInformation]	U	
DM63 NOT CURRENT DATA AUTHORITY	U	
DM65 DUE TO WEATHER	U	
DM66 DUE TO AIRCRAFT PERFORMANCE	U	
DM81 WE CAN ACCEPT [level] AT [time]	C	
DM82 WE CANNOT ACCEPT [level]	C	
DM89 MONITORING [unitname] [frequency]	C	
DM98 [freetext]	U	
DM99 CURRENT DATA AUTHORITY	U	
DM100 LOGICAL ACKNOWLEDGMENT	U	
DM106 PREFERRED LEVEL [level]	C	
DM107 NOT AUTHORIZED NEXT DATA AUTHORITY	U	
DM109 TOP OF DESCENT [time]	C	
NOTE: "U" stands for "unconditional" means that it has to be supported. "C" stands for "conditional" means that it has to be supported under certain condition.		

## 6.2 Eurocontrol DLS Specification, clauses B.3.2 and B.3.3

The PICS/OICS for CM and CPDLC as contained in ED-110B [6], annex B shall be completed for all implementations.

NOTE: There are no additional constraints placed on the requirements for the Transport Protocol PICS other than those specified in ICAO Doc 9705 [4].

## 6.3 Eurocontrol DLS Specification, clause B.3.4

Unless specified to the contrary in the present document, implementations shall comply with the relevant Profile Requirements Lists for the ATN ULCS and ICS in Doc 9705 [4], Sub-Volumes IV and V.

## 6.4 Eurocontrol DLS Specification, clause C.3

Tables 18 and 19 shall be completed to show conformance to the present document.

**Table 17: Publication of related information**

Clause	Requirement	Conformance	Implementation
4.3.5	All operational details with respect to the transfer of communications using CPDLC shall be reflected accordingly in Letters of Agreement established between the ATC units concerned.	U	
4.3.6	ATN application entity titles and ATN addresses including LOC, SYS and NSEL values shall be assigned in accordance with the data link services supported.	U	
4.3.7	Ground ATC entities shall be identified by an ICAO Facility Designator and the corresponding CM TSEL value.	U	
4.3.8	Ground system addresses required for the DLIC Logon function shall be included in national aeronautical information publications.	U	
NOTE:	"U" stands for "unconditional" means that it has to be supported. "C" stands for "conditional" means that it has to be supported under certain conditions.		

**Table 18: Operational Procedures**

Clause	Requirement	Conformance	Implementation
4.3.1	Operation of the identified Data Link Services shall comply with the requirements of chapter 14 (CPDLC) of ICAO Doc. 4444 PANS-ATM and with the requirements of Chapter 8 (Aeronautical Mobile Service - Data Link Communications) of ICAO Annex 10, Volume II.	U	
4.3.3	Where CPDLC-related voice communications are required, the controller and pilot shall use the appropriate phraseologies as detailed in PANS-ATM, section 14.3, whenever possible.	U	
4.3.4	When there is a need to issue a clearance that is dependent on the successful outcome of a previously issued clearance, the controller shall wait until the execution of that earlier clearance has been completed before the new clearance is issued.	U	
NOTE:	"U" stands for "unconditional" means that it has to be supported. "C" stands for "conditional" means that it has to be supported under certain conditions.		

## 6.5 Eurocontrol Specification, clause D.3.2

PICS for VDL-Mode 2 implementations are contained in ARINC 631 [10] Attachment 2 (Data Link Layer PICS) and Attachment 3 (Sub-network Layer PICS), and shall be completed for all implementations.



## Annex SA (normative): Standards Annex

The present annex provides a relationship between the present document and the Essential Requirements of the Single European Sky Interoperability Regulation [i.6].

The ground implementation of data link services, derived from the ICAO standard Context Management (CM) and Controller Pilot Data Link Communication (CPDLC) applications shall comply with the Essential Requirements of the Interoperability Regulation [i.6] as defined and described in the traceability matrixes of the present annex (tables SA.1 and SA.2 below).

### SA.1 Correspondence between this European Standard and the Single European Sky Interoperability Regulation (as amended) for the ground implementation of data link services, derived from the ICAO standard Context Management (CM) and Controller Pilot Data Link Communication (CPDLC) applications

**Table SA.1: Traceability from Interoperability Regulation (as amended) to clauses of the present document**

<b>(Essential) Requirements (ERs) of SES Interoperability Regulation, Annex II, Part A</b>	<b>Clause(s) of the present document</b>	<b>Qualifying remarks/Notes</b>
ER 1 Seamless operation.	<b>4.1.1</b> Unconditional Constituent - Ground Ground ATN Routers <b>4.1.2</b> Unconditional Constituent - ATM Data Processing <b>4.1.3</b> Unconditional Constituent - Ground Data Recording equipment <b>4.1.4</b> Unconditional Constituent - Ground Display (HMI) <b>4.1.5</b> Conditional Constituent - Air Ground ATN Routers <b>4.1.6</b> Conditional Constituent - VDL Mode 2 ground communications equipment <b>4.2</b> Design Requirements for DLS ground constituents <b>4.2.1</b> Performance Requirements <b>4.2.3.1.1</b> Specific Interoperability Requirements <b>4.2.3.1.2</b> Specific Performance Requirements <b>4.2.3.2.1</b> Specific Interoperability Requirements <b>4.2.3.2.4</b> Specific Performance Requirements <b>4.2.3.3.1</b> Specific Interoperability Requirements <b>4.2.3.3.6</b> Specific Performance Requirements <b>4.2.3.4.1</b> Specific Interoperability Requirements	For system and associated procedures only; does not cover maintenance

<b>(Essential) Requirements (ERs) of SES Interoperability Regulation, Annex II, Part A</b>	<b>Clause(s) of the present document</b>	<b>Qualifying remarks/Notes</b>
	<b>4.2.3.4.4</b> Specific Performance Requirements <b>4.3</b> Associated Procedures (including all sub-clauses) <b>5</b> System Testing (including all sub-clauses) <b>6</b> Conformity Assessment materials (including all sub-clauses)	
ER 2 Support for new concepts of operation.	<b>4.2.1</b> Performance Requirements <b>4.2.2</b> Safety Requirements <b>4.2.3.1.2</b> Specific Performance Requirements <b>4.2.3.1.3</b> Specific Safety Requirements <b>4.2.3.2.4</b> Specific Performance Requirements <b>4.2.3.2.5</b> Specific Safety Requirements <b>4.2.3.3.6</b> Specific Performance Requirements <b>4.2.3.3.7</b> Specific Safety Requirements <b>4.2.3.4.4</b> Specific Performance Requirements <b>4.2.3.4.5</b> Specific Safety Requirements <b>6</b> Conformity Assessment materials (including all sub-clauses)	For system level only; up to ATM Service Level 0/Capability Level 1 of the ATM Master Plan [i.8].
ER 3 Safety.	<b>4.1.4.1</b> Eurocontrol DLS Specification, clause A.2.1.5 <b>4.1.4.2</b> Eurocontrol DLS Specification, clause A.2.1.6 <b>4.2.2</b> Safety Requirements <b>4.2.3.1.3</b> Specific Safety Requirements <b>4.2.3.2.5</b> Specific Safety Requirements <b>4.2.3.3.7</b> Specific Safety Requirements <b>4.2.3.4.5</b> Specific Safety Requirements <b>4.3</b> Associated Procedures <b>5</b> System Testing (including all sub-clauses) <b>6</b> Conformity Assessment materials (including all sub-clauses)	For system and procedure level only; does not cover maintenance.
ER 4 Civil-military coordination.		The present document does not give presumption of conformity.
ER 5 Environmental constraints.		The present document does not give presumption of conformity.
ER 6 Principles governing the logical architecture of systems.	<b>4.1</b> Constituents of a DLS System (including all sub-clauses) <b>5</b> System Testing (including all sub-clauses)	For system level only.
ER 7 Principles governing the construction of systems.	<b>4.1</b> Constituents of a DLS System (including all sub-clauses) <b>4.1.1.1</b> Eurocontrol DLS Specification, clause B.2.1.1 <b>4.1.6</b> Conditional Constituent - VDL Mode 2 ground communications equipment <b>4.2.1</b> Performance Requirements <b>4.2.3.1.2</b> Specific Performance Requirements <b>4.2.3.2.4</b> Specific Performance Requirements <b>4.2.3.3.6</b> Specific Performance Requirements <b>4.2.3.4.4</b> Specific Performance Requirements	For system level only; limited to modularity and interchangeability at the interface between ATSP-domain.

<b>(Essential) Requirements (ERs) of SES Interoperability Regulation, Annex II, Part B</b>	<b>Clause(s) of the present document</b>	<b>Qualifying remarks/Notes</b>
ER 1.1 Seamless operation of airspace management.		Not covered by the present document.
ER 2.1 Seamless operation of air traffic flow management.		Not covered by the present document.
ER 3.1.1 Seamless operation of flight data processing.		Not covered by the present document.
ER 3.1.2 Support for new concepts of operation for flight data processing.		Not covered by the present document.
ER 3.2.1 Seamless operation surveillance data processing systems.		Not covered by the present document.
ER 3.2.2 Support for new concepts of operation for surveillance data processing systems.		Not covered by the present document.
ER 3.3.1 Seamless operation of Human-machine interface systems.	<b>4.1.4</b> Unconditional Constituent - Ground Display (HMI)	For design only; only as far as DL is concerned.
ER 3.3.2 Support for new concepts of operation for Human-machine interface systems.	<b>4.1.4</b> Unconditional Constituent - Ground Display (HMI)	For design only; only as far as DL is concerned.
ER 4.1 Seamless operation of Communications systems and procedures for ground-to-ground, air-to-ground and air-to-air communications.	<b>4</b> Requirements for implementing Data Link Services (including all sub-clauses) <b>5</b> System Testing (including all sub-clauses) <b>6</b> Conformity Assessment materials (including all sub-clauses)	Does not cover maintenance.
ER 4.2 Support for new concepts of operation for Communications systems and procedures for ground-to-ground, air-to-ground and air-to-air communications.	<b>4</b> Requirements for implementing Data Link Services (including all sub-clauses) <b>5</b> System Testing (including all sub-clauses) <b>6</b> Conformity Assessment materials (including all sub-clauses)	
ER 5.1 Seamless operation of Navigation systems and procedures.		Not covered by the present document.
ER 6.1 Seamless operation of Surveillance systems and procedures.		Not covered by the present document.
ER 7.1 Seamless operation of systems and procedures for aeronautical information services.		Not covered by the present document.
ER 7.2 Support for new concepts of operation for systems and procedures for aeronautical information services.		Not covered by the present document.
ER 8.1 Seamless operation of systems and procedures for the use of meteorological information.		Not covered by the present document.
ER 8.2 Support for new concepts of operation for systems and procedures for the use of meteorological information.		Not covered by the present document.

**Table SA.2: Traceability from clauses of the present document to Interoperability Regulation (as amended)**

Clause(s) of the present document	(Essential) Requirements (ERs) of SES Interoperability Regulation (as amended), Annex II, Parts A and B	Qualifying remarks/Notes
4.0		
4.1.1.1	ER 1 Seamless operation ER 6 Principles governing the logical architecture of systems ER 4.1 Seamless operation of Communications systems and procedures for ground-to-ground, air-to-ground and air-to-air communications ER 4.2 Support for new concepts of operation for Communications systems and procedures for ground-to-ground, air-to-ground and air-to-air communications	
4.1.1.2	ER 1 Seamless operation ER 6 Principles governing the logical architecture of systems ER 4.1 Seamless operation of Communications systems and procedures for ground-to-ground, air-to-ground and air-to-air communications ER 4.2 Support for new concepts of operation for Communications systems and procedures for ground-to-ground, air-to-ground and air-to-air communications	
4.1.1.3	ER 1 Seamless operation ER 6 Principles governing the logical architecture of systems ER 4.1 Seamless operation of Communications systems and procedures for ground-to-ground, air-to-ground and air-to-air communications ER 4.2 Support for new concepts of operation for Communications systems and procedures for ground-to-ground, air-to-ground and air-to-air communications	
4.1.1.4	ER 1 Seamless operation ER 6 Principles governing the logical architecture of systems ER 4.1 Seamless operation of Communications systems and procedures for ground-to-ground, air-to-ground and air-to-air communications ER 4.2 Support for new concepts of operation for Communications systems and procedures for ground-to-ground, air-to-ground and air-to-air communications	

Clause(s) of the present document	(Essential) Requirements (ERs) of SES Interoperability Regulation (as amended), Annex II, Parts A and B	Qualifying remarks/Notes
4.1.1.5	ER 1 Seamless operation ER 6 Principles governing the logical architecture of systems ER 4.1 Seamless operation of Communications systems and procedures for ground-to-ground, air-to-ground and air-to-air communications ER 4.2 Support for new concepts of operation for Communications systems and procedures for ground-to-ground, air-to-ground and air-to-air communications	
4.1.1.6	ER 1 Seamless operation ER 6 Principles governing the logical architecture of systems ER 4.1 Seamless operation of Communications systems and procedures for ground-to-ground, air-to-ground and air-to-air communications ER 4.2 Support for new concepts of operation for Communications systems and procedures for ground-to-ground, air-to-ground and air-to-air communications	
4.1.2.1	ER 1 Seamless operation ER 6 Principles governing the logical architecture of systems ER 4.1 Seamless operation of Communications systems and procedures for ground-to-ground, air-to-ground and air-to-air communications ER 4.2 Support for new concepts of operation for Communications systems and procedures for ground-to-ground, air-to-ground and air-to-air communications	
4.1.2.2	ER 1 Seamless operation ER 6 Principles governing the logical architecture of systems ER 4.1 Seamless operation of Communications systems and procedures for ground-to-ground, air-to-ground and air-to-air communications ER 4.2 Support for new concepts of operation for Communications systems and procedures for ground-to-ground, air-to-ground and air-to-air communications	
4.1.2.3	ER 1 Seamless operation ER 6 Principles governing the logical architecture of systems ER 4.1 Seamless operation of Communications systems and procedures for ground-to-ground, air-to-ground and air-to-air communications ER 4.2 Support for new concepts of operation for Communications systems and procedures for ground-to-ground, air-to-ground and air-to-air communications	

Clause(s) of the present document	(Essential) Requirements (ERs) of SES Interoperability Regulation (as amended), Annex II, Parts A and B	Qualifying remarks/Notes
4.1.2.4	Void	
4.1.2.5	ER 1 Seamless operation ER 6 Principles governing the logical architecture of systems ER 4.1 Seamless operation of Communications systems and procedures for ground-to-ground, air-to-ground and air-to-air communications ER 4.2 Support for new concepts of operation for Communications systems and procedures for ground-to-ground, air-to-ground and air-to-air communications	
4.1.2.6	ER 1 Seamless operation ER 6 Principles governing the logical architecture of systems ER 4.1 Seamless operation of Communications systems and procedures for ground-to-ground, air-to-ground and air-to-air communications ER 4.2 Support for new concepts of operation for Communications systems and procedures for ground-to-ground, air-to-ground and air-to-air communications	
4.1.2.7	ER 1 Seamless operation ER 6 Principles governing the logical architecture of systems ER 4.1 Seamless operation of Communications systems and procedures for ground-to-ground, air-to-ground and air-to-air communications ER 4.2 Support for new concepts of operation for Communications systems and procedures for ground-to-ground, air-to-ground and air-to-air communications	
4.1.2.8	ER 1 Seamless operation ER 6 Principles governing the logical architecture of systems ER 4.1 Seamless operation of Communications systems and procedures for ground-to-ground, air-to-ground and air-to-air communications ER 4.2 Support for new concepts of operation for Communications systems and procedures for ground-to-ground, air-to-ground and air-to-air communications	

Clause(s) of the present document	(Essential) Requirements (ERs) of SES Interoperability Regulation (as amended), Annex II, Parts A and B	Qualifying remarks/Notes
4.1.2.9	ER 1 Seamless operation ER 6 Principles governing the logical architecture of systems ER 4.1 Seamless operation of Communications systems and procedures for ground-to-ground, air-to-ground and air-to-air communications ER 4.2 Support for new concepts of operation for Communications systems and procedures for ground-to-ground, air-to-ground and air-to-air communications	
4.1.2.10	ER 1 Seamless operation ER 6 Principles governing the logical architecture of systems ER 4.1 Seamless operation of Communications systems and procedures for ground-to-ground, air-to-ground and air-to-air communications ER 4.2 Support for new concepts of operation for Communications systems and procedures for ground-to-ground, air-to-ground and air-to-air communications	
4.1.2.11	ER 1 Seamless operation ER 6 Principles governing the logical architecture of systems ER 4.1 Seamless operation of Communications systems and procedures for ground-to-ground, air-to-ground and air-to-air communications ER 4.2 Support for new concepts of operation for Communications systems and procedures for ground-to-ground, air-to-ground and air-to-air communications	
4.1.2.12	ER 1 Seamless operation ER 6 Principles governing the logical architecture of systems ER 4.1 Seamless operation of Communications systems and procedures for ground-to-ground, air-to-ground and air-to-air communications ER 4.2 Support for new concepts of operation for Communications systems and procedures for ground-to-ground, air-to-ground and air-to-air communications	
4.1.2.13	ER 1 Seamless operation ER 6 Principles governing the logical architecture of systems ER 4.1 Seamless operation of Communications systems and procedures for ground-to-ground, air-to-ground and air-to-air communications ER 4.2 Support for new concepts of operation for Communications systems and procedures for ground-to-ground, air-to-ground and air-to-air communications	

Clause(s) of the present document	(Essential) Requirements (ERs) of SES Interoperability Regulation (as amended), Annex II, Parts A and B	Qualifying remarks/Notes
4.1.2.14	ER 1 Seamless operation ER 6 Principles governing the logical architecture of systems ER 4.1 Seamless operation of Communications systems and procedures for ground-to-ground, air-to-ground and air-to-air communications ER 4.2 Support for new concepts of operation for Communications systems and procedures for ground-to-ground, air-to-ground and air-to-air communications	
4.1.2.15	ER 1 Seamless operation ER 6 Principles governing the logical architecture of systems ER 4.1 Seamless operation of Communications systems and procedures for ground-to-ground, air-to-ground and air-to-air communications ER 4.2 Support for new concepts of operation for Communications systems and procedures for ground-to-ground, air-to-ground and air-to-air communications	
4.1.2.16	ER 1 Seamless operation ER 6 Principles governing the logical architecture of systems ER 4.1 Seamless operation of Communications systems and procedures for ground-to-ground, air-to-ground and air-to-air communications ER 4.2 Support for new concepts of operation for Communications systems and procedures for ground-to-ground, air-to-ground and air-to-air communications	
4.1.2.17	ER 1 Seamless operation ER 6 Principles governing the logical architecture of systems ER 4.1 Seamless operation of Communications systems and procedures for ground-to-ground, air-to-ground and air-to-air communications ER 4.2 Support for new concepts of operation for Communications systems and procedures for ground-to-ground, air-to-ground and air-to-air communications	
4.1.2.18	ER 1 Seamless operation ER 6 Principles governing the logical architecture of systems ER 4.1 Seamless operation of Communications systems and procedures for ground-to-ground, air-to-ground and air-to-air communications ER 4.2 Support for new concepts of operation for Communications systems and procedures for ground-to-ground, air-to-ground and air-to-air communications	



Clause(s) of the present document	(Essential) Requirements (ERs) of SES Interoperability Regulation (as amended), Annex II, Parts A and B	Qualifying remarks/Notes
4.1.2.19	ER 1 Seamless operation ER 6 Principles governing the logical architecture of systems ER 4.1 Seamless operation of Communications systems and procedures for ground-to-ground, air-to-ground and air-to-air communications ER 4.2 Support for new concepts of operation for Communications systems and procedures for ground-to-ground, air-to-ground and air-to-air communications	
4.1.2.20	ER 1 Seamless operation ER 6 Principles governing the logical architecture of systems ER 4.1 Seamless operation of Communications systems and procedures for ground-to-ground, air-to-ground and air-to-air communications ER 4.2 Support for new concepts of operation for Communications systems and procedures for ground-to-ground, air-to-ground and air-to-air communications	
4.1.2.21	ER 1 Seamless operation ER 6 Principles governing the logical architecture of systems ER 4.1 Seamless operation of Communications systems and procedures for ground-to-ground, air-to-ground and air-to-air communications ER 4.2 Support for new concepts of operation for Communications systems and procedures for ground-to-ground, air-to-ground and air-to-air communications	
4.1.2.22	ER 1 Seamless operation ER 6 Principles governing the logical architecture of systems ER 4.1 Seamless operation of Communications systems and procedures for ground-to-ground, air-to-ground and air-to-air communications ER 4.2 Support for new concepts of operation for Communications systems and procedures for ground-to-ground, air-to-ground and air-to-air communications	
4.1.2.23	ER 1 Seamless operation ER 6 Principles governing the logical architecture of systems ER 4.1 Seamless operation of Communications systems and procedures for ground-to-ground, air-to-ground and air-to-air communications ER 4.2 Support for new concepts of operation for Communications systems and procedures for ground-to-ground, air-to-ground and air-to-air communications	

Clause(s) of the present document	(Essential) Requirements (ERs) of SES Interoperability Regulation (as amended), Annex II, Parts A and B	Qualifying remarks/Notes
4.1.2.24	ER 1 Seamless operation ER 6 Principles governing the logical architecture of systems ER 4.1 Seamless operation of Communications systems and procedures for ground-to-ground, air-to-ground and air-to-air communications ER 4.2 Support for new concepts of operation for Communications systems and procedures for ground-to-ground, air-to-ground and air-to-air communications	
4.1.2.25	ER 1 Seamless operation ER 6 Principles governing the logical architecture of systems ER 4.1 Seamless operation of Communications systems and procedures for ground-to-ground, air-to-ground and air-to-air communications ER 4.2 Support for new concepts of operation for Communications systems and procedures for ground-to-ground, air-to-ground and air-to-air communications	
4.1.2.26	ER 1 Seamless operation ER 6 Principles governing the logical architecture of systems ER 4.1 Seamless operation of Communications systems and procedures for ground-to-ground, air-to-ground and air-to-air communications ER 4.2 Support for new concepts of operation for Communications systems and procedures for ground-to-ground, air-to-ground and air-to-air communications	
4.1.2.27	ER 1 Seamless operation ER 6 Principles governing the logical architecture of systems ER 4.1 Seamless operation of Communications systems and procedures for ground-to-ground, air-to-ground and air-to-air communications ER 4.2 Support for new concepts of operation for Communications systems and procedures for ground-to-ground, air-to-ground and air-to-air communications	
4.1.2.28	Void	
4.1.2.29	Void	
4.1.2.30	Void	

Clause(s) of the present document	(Essential) Requirements (ERs) of SES Interoperability Regulation (as amended), Annex II, Parts A and B	Qualifying remarks/Notes
4.1.2.31	ER 1 Seamless operation ER 6 Principles governing the logical architecture of systems ER 4.1 Seamless operation of Communications systems and procedures for ground-to-ground, air-to-ground and air-to-air communications ER 4.2 Support for new concepts of operation for Communications systems and procedures for ground-to-ground, air-to-ground and air-to-air communications	
4.1.2.32	Void	
4.1.2.33	ER 1 Seamless operation ER 6 Principles governing the logical architecture of systems ER 4.1 Seamless operation of Communications systems and procedures for ground-to-ground, air-to-ground and air-to-air communications ER 4.2 Support for new concepts of operation for Communications systems and procedures for ground-to-ground, air-to-ground and air-to-air communications	
4.1.3	ER 1 Seamless operation ER 6 Principles governing the logical architecture of systems ER 4.1 Seamless operation of Communications systems and procedures for ground-to-ground, air-to-ground and air-to-air communications ER 4.2 Support for new concepts of operation for Communications systems and procedures for ground-to-ground, air-to-ground and air-to-air communications	
4.1.4.1	ER 1 Seamless operation ER 3 Safety ER 6 Principles governing the logical architecture of systems ER 3.3.1 Seamless operation of Human-machine interface systems ER 3.3.2 Support for new concepts of operation for Human-machine interface systems ER 4.1 Seamless operation of Communications systems and procedures for ground-to-ground, air-to-ground and air-to-air communications ER 4.2 Support for new concepts of operation for Communications systems and procedures for ground-to-ground, air-to-ground and air-to-air communications	

Clause(s) of the present document	(Essential) Requirements (ERs) of SES Interoperability Regulation (as amended), Annex II, Parts A and B	Qualifying remarks/Notes
4.1.4.2	ER 1 Seamless operation ER 3 Safety ER 6 Principles governing the logical architecture of systems ER 3.3.1 Seamless operation of Human-machine interface systems ER 3.3.2 Support for new concepts of operation for Human-machine interface systems ER 4.1 Seamless operation of Communications systems and procedures for ground-to-ground, air-to-ground and air-to-air communications ER 4.2 Support for new concepts of operation for Communications systems and procedures for ground-to-ground, air-to-ground and air-to-air communications	
4.1.5.1	ER 1 Seamless operation ER 6 Principles governing the logical architecture of systems ER 4.1 Seamless operation of Communications systems and procedures for ground-to-ground, air-to-ground and air-to-air communications ER 4.2 Support for new concepts of operation for Communications systems and procedures for ground-to-ground, air-to-ground and air-to-air communications	
4.1.5.2	ER 1 Seamless operation ER 6 Principles governing the logical architecture of systems ER 4.1 Seamless operation of Communications systems and procedures for ground-to-ground, air-to-ground and air-to-air communications ER 4.2 Support for new concepts of operation for Communications systems and procedures for ground-to-ground, air-to-ground and air-to-air communications	
4.1.5.3	ER 1 Seamless operation ER 6 Principles governing the logical architecture of systems ER 4.1 Seamless operation of Communications systems and procedures for ground-to-ground, air-to-ground and air-to-air communications ER 4.2 Support for new concepts of operation for Communications systems and procedures for ground-to-ground, air-to-ground and air-to-air communications	

Clause(s) of the present document	(Essential) Requirements (ERs) of SES Interoperability Regulation (as amended), Annex II, Parts A and B	Qualifying remarks/Notes
4.1.5.4	ER 1 Seamless operation ER 6 Principles governing the logical architecture of systems ER 4.1 Seamless operation of Communications systems and procedures for ground-to-ground, air-to-ground and air-to-air communications ER 4.2 Support for new concepts of operation for Communications systems and procedures for ground-to-ground, air-to-ground and air-to-air communications	
4.1.5.5	ER 1 Seamless operation ER 6 Principles governing the logical architecture of systems ER 4.1 Seamless operation of Communications systems and procedures for ground-to-ground, air-to-ground and air-to-air communications ER 4.2 Support for new concepts of operation for Communications systems and procedures for ground-to-ground, air-to-ground and air-to-air communications	
4.1.5.6	ER 1 Seamless operation ER 6 Principles governing the logical architecture of systems ER 4.1 Seamless operation of Communications systems and procedures for ground-to-ground, air-to-ground and air-to-air communications ER 4.2 Support for new concepts of operation for Communications systems and procedures for ground-to-ground, air-to-ground and air-to-air communications	
4.1.6.1.1	ER 1 Seamless operation ER 6 Principles governing the logical architecture of systems ER 4.1 Seamless operation of Communications systems and procedures for ground-to-ground, air-to-ground and air-to-air communications ER 4.2 Support for new concepts of operation for Communications systems and procedures for ground-to-ground, air-to-ground and air-to-air communications	
4.1.6.2.1	ER 1 Seamless operation ER 6 Principles governing the logical architecture of systems ER 4.1 Seamless operation of Communications systems and procedures for ground-to-ground, air-to-ground and air-to-air communications ER 4.2 Support for new concepts of operation for Communications systems and procedures for ground-to-ground, air-to-ground and air-to-air communications	

Clause(s) of the present document	(Essential) Requirements (ERs) of SES Interoperability Regulation (as amended), Annex II, Parts A and B	Qualifying remarks/Notes
4.1.6.2.2	ER 1 Seamless operation ER 6 Principles governing the logical architecture of systems ER 4.1 Seamless operation of Communications systems and procedures for ground-to-ground, air-to-ground and air-to-air communications ER 4.2 Support for new concepts of operation for Communications systems and procedures for ground-to-ground, air-to-ground and air-to-air communications	
4.1.6.2.3	ER 1 Seamless operation ER 6 Principles governing the logical architecture of systems ER 4.1 Seamless operation of Communications systems and procedures for ground-to-ground, air-to-ground and air-to-air communications ER 4.2 Support for new concepts of operation for Communications systems and procedures for ground-to-ground, air-to-ground and air-to-air communications	
4.1.6.3	ER 1 Seamless operation ER 6 Principles governing the logical architecture of systems ER 4.1 Seamless operation of Communications systems and procedures for ground-to-ground, air-to-ground and air-to-air communications ER 4.2 Support for new concepts of operation for Communications systems and procedures for ground-to-ground, air-to-ground and air-to-air communications	
4.1.6.4	ER 1 Seamless operation ER 6 Principles governing the logical architecture of systems ER 4.1 Seamless operation of Communications systems and procedures for ground-to-ground, air-to-ground and air-to-air communications ER 4.2 Support for new concepts of operation for Communications systems and procedures for ground-to-ground, air-to-ground and air-to-air communications	

Clause(s) of the present document	(Essential) Requirements (ERs) of SES Interoperability Regulation (as amended), Annex II, Parts A and B	Qualifying remarks/Notes
4.2.1	ER 1 Seamless operation ER 2 Support for new concepts of operation ER 6 Principles governing the logical architecture of systems ER 4.1 Seamless operation of Communications systems and procedures for ground-to-ground, air-to-ground and air-to-air communications ER 4.2 Support for new concepts of operation for Communications systems and procedures for ground-to-ground, air-to-ground and air-to-air communications	
4.2.2	ER 1 Seamless operation ER 2 Support for new concepts of operation ER 3 Safety ER 4.1 Seamless operation of Communications systems and procedures for ground-to-ground, air-to-ground and air-to-air communications ER 4.2 Support for new concepts of operation for Communications systems and procedures for ground-to-ground, air-to-ground and air-to-air communications	
4.2.3.1.1.1	ER 1 Seamless operation ER 4.1 Seamless operation of Communications systems and procedures for ground-to-ground, air-to-ground and air-to-air communications ER 4.2 Support for new concepts of operation for Communications systems and procedures for ground-to-ground, air-to-ground and air-to-air communications	
4.2.3.1.1.2	ER 1 Seamless operation ER 4.1 Seamless operation of Communications systems and procedures for ground-to-ground, air-to-ground and air-to-air communications ER 4.2 Support for new concepts of operation for Communications systems and procedures for ground-to-ground, air-to-ground and air-to-air communications	
4.2.3.1.1.3	ER 1 Seamless operation ER 4.1 Seamless operation of Communications systems and procedures for ground-to-ground, air-to-ground and air-to-air communications ER 4.2 Support for new concepts of operation for Communications systems and procedures for ground-to-ground, air-to-ground and air-to-air communications	

Clause(s) of the present document	(Essential) Requirements (ERs) of SES Interoperability Regulation (as amended), Annex II, Parts A and B	Qualifying remarks/Notes
4.2.3.1.1.4	ER 1 Seamless operation ER 4.1 Seamless operation of Communications systems and procedures for ground-to-ground, air-to-ground and air-to-air communications ER 4.2 Support for new concepts of operation for Communications systems and procedures for ground-to-ground, air-to-ground and air-to-air communications	
4.2.3.1.1.5	ER 1 Seamless operation ER 4.1 Seamless operation of Communications systems and procedures for ground-to-ground, air-to-ground and air-to-air communications ER 4.2 Support for new concepts of operation for Communications systems and procedures for ground-to-ground, air-to-ground and air-to-air communications	
4.2.3.1.1.6	ER 1 Seamless operation ER 4.1 Seamless operation of Communications systems and procedures for ground-to-ground, air-to-ground and air-to-air communications ER 4.2 Support for new concepts of operation for Communications systems and procedures for ground-to-ground, air-to-ground and air-to-air communications	
4.2.3.1.2	ER 1 Seamless operation ER 2 Support for new concepts of operation ER 6 Principles governing the logical architecture of systems ER 4.1 Seamless operation of Communications systems and procedures for ground-to-ground, air-to-ground and air-to-air communications ER 4.2 Support for new concepts of operation for Communications systems and procedures for ground-to-ground, air-to-ground and air-to-air communications	
4.2.3.1.3	ER 1 Seamless operation ER 2 Support for new concepts of operation ER 3 Safety ER 4.1 Seamless operation of Communications systems and procedures for ground-to-ground, air-to-ground and air-to-air communications ER 4.2 Support for new concepts of operation for Communications systems and procedures for ground-to-ground, air-to-ground and air-to-air communications	



Clause(s) of the present document	(Essential) Requirements (ERs) of SES Interoperability Regulation (as amended), Annex II, Parts A and B	Qualifying remarks/Notes
4.2.3.2.1.1	ER 1 Seamless operation ER 4.1 Seamless operation of Communications systems and procedures for ground-to-ground, air-to-ground and air-to-air communications ER 4.2 Support for new concepts of operation for Communications systems and procedures for ground-to-ground, air-to-ground and air-to-air communications	
4.2.3.2.1.2	ER 1 Seamless operation ER 4.1 Seamless operation of Communications systems and procedures for ground-to-ground, air-to-ground and air-to-air communications ER 4.2 Support for new concepts of operation for Communications systems and procedures for ground-to-ground, air-to-ground and air-to-air communications	
4.2.3.2.1.3	ER 1 Seamless operation ER 4.1 Seamless operation of Communications systems and procedures for ground-to-ground, air-to-ground and air-to-air communications ER 4.2 Support for new concepts of operation for Communications systems and procedures for ground-to-ground, air-to-ground and air-to-air communications	
4.2.2.2.1.4	ER 1 Seamless operation ER 4.1 Seamless operation of Communications systems and procedures for ground-to-ground, air-to-ground and air-to-air communications ER 4.2 Support for new concepts of operation for Communications systems and procedures for ground-to-ground, air-to-ground and air-to-air communications	
4.2.3.2.2.1	ER 1 Seamless operation ER 4.1 Seamless operation of Communications systems and procedures for ground-to-ground, air-to-ground and air-to-air communications ER 4.2 Support for new concepts of operation for Communications systems and procedures for ground-to-ground, air-to-ground and air-to-air communications	

Clause(s) of the present document	(Essential) Requirements (ERs) of SES Interoperability Regulation (as amended), Annex II, Parts A and B	Qualifying remarks/Notes
4.2.3.2.3	ER 1 Seamless operation ER 4.1 Seamless operation of Communications systems and procedures for ground-to-ground, air-to-ground and air-to-air communications ER 4.2 Support for new concepts of operation for Communications systems and procedures for ground-to-ground, air-to-ground and air-to-air communications	
4.2.3.2.4	ER 1 Seamless operation ER 2 Support for new concepts of operation ER 6 Principles governing the logical architecture of systems ER 4.1 Seamless operation of Communications systems and procedures for ground-to-ground, air-to-ground and air-to-air communications ER 4.2 Support for new concepts of operation for Communications systems and procedures for ground-to-ground, air-to-ground and air-to-air communications	
4.2.3.2.5	ER 1 Seamless operation ER 2 Support for new concepts of operation ER 3 Safety ER 4.1 Seamless operation of Communications systems and procedures for ground-to-ground, air-to-ground and air-to-air communications ER 4.2 Support for new concepts of operation for Communications systems and procedures for ground-to-ground, air-to-ground and air-to-air communications	
4.2.3.3.1	ER 1 Seamless operation ER 4.1 Seamless operation of Communications systems and procedures for ground-to-ground, air-to-ground and air-to-air communications ER 4.2 Support for new concepts of operation for Communications systems and procedures for ground-to-ground, air-to-ground and air-to-air communications	
4.2.3.3.2	ER 1 Seamless operation ER 4.1 Seamless operation of Communications systems and procedures for ground-to-ground, air-to-ground and air-to-air communications ER 4.2 Support for new concepts of operation for Communications systems and procedures for ground-to-ground, air-to-ground and air-to-air communications	

Clause(s) of the present document	(Essential) Requirements (ERs) of SES Interoperability Regulation (as amended), Annex II, Parts A and B	Qualifying remarks/Notes
4.2.3.3.3	ER 1 Seamless operation ER 4.1 Seamless operation of Communications systems and procedures for ground-to-ground, air-to-ground and air-to-air communications ER 4.2 Support for new concepts of operation for Communications systems and procedures for ground-to-ground, air-to-ground and air-to-air communications	
4.2.3.3.4	Void	
4.2.3.3.5	Void	
4.2.3.3.6	ER 1 Seamless operation ER 2 Support for new concepts of operation ER 6 Principles governing the logical architecture of systems ER 4.1 Seamless operation of Communications systems and procedures for ground-to-ground, air-to-ground and air-to-air communications ER 4.2 Support for new concepts of operation for Communications systems and procedures for ground-to-ground, air-to-ground and air-to-air communications	
4.2.3.3.7.1	ER 1 Seamless operation ER 2 Support for new concepts of operation ER 3 Safety ER 4.1 Seamless operation of Communications systems and procedures for ground-to-ground, air-to-ground and air-to-air communications ER 4.2 Support for new concepts of operation for Communications systems and procedures for ground-to-ground, air-to-ground and air-to-air communications	
4.2.3.4.1	ER 1 Seamless operation ER 4.1 Seamless operation of Communications systems and procedures for ground-to-ground, air-to-ground and air-to-air communications ER 4.2 Support for new concepts of operation for Communications systems and procedures for ground-to-ground, air-to-ground and air-to-air communications	
4.2.3.4.2	ER 1 Seamless operation ER 4.1 Seamless operation of Communications systems and procedures for ground-to-ground, air-to-ground and air-to-air communications ER 4.2 Support for new concepts of operation for Communications systems and procedures for ground-to-ground, air-to-ground and air-to-air communications	

Clause(s) of the present document	(Essential) Requirements (ERs) of SES Interoperability Regulation (as amended), Annex II, Parts A and B	Qualifying remarks/Notes
4.2.3.4.3	ER 1 Seamless operation ER 4.1 Seamless operation of Communications systems and procedures for ground-to-ground, air-to-ground and air-to-air communications ER 4.2 Support for new concepts of operation for Communications systems and procedures for ground-to-ground, air-to-ground and air-to-air communications	
4.2.3.4.4	ER 1 Seamless operation ER 2 Support for new concepts of operation ER 6 Principles governing the logical architecture of systems ER 4.1 Seamless operation of Communications systems and procedures for ground-to-ground, air-to-ground and air-to-air communications ER 4.2 Support for new concepts of operation for Communications systems and procedures for ground-to-ground, air-to-ground and air-to-air communications	
4.2.3.4.5	ER 1 Seamless operation ER 2 Support for new concepts of operation ER 3 Safety ER 4.1 Seamless operation of Communications systems and procedures for ground-to-ground, air-to-ground and air-to-air communications ER 4.2 Support for new concepts of operation for Communications systems and procedures for ground-to-ground, air-to-ground and air-to-air communications	
4.3.1	ER 1 Seamless operation ER 3 Safety ER 4.1 Seamless operation of Communications systems and procedures for ground-to-ground, air-to-ground and air-to-air communications ER 4.2 Support for new concepts of operation for Communications systems and procedures for ground-to-ground, air-to-ground and air-to-air communications	
4.3.2	ER 1 Seamless operation ER 3 Safety ER 4.1 Seamless operation of Communications systems and procedures for ground-to-ground, air-to-ground and air-to-air communications ER 4.2 Support for new concepts of operation for Communications systems and procedures for ground-to-ground, air-to-ground and air-to-air communications	

Clause(s) of the present document	(Essential) Requirements (ERs) of SES Interoperability Regulation (as amended), Annex II, Parts A and B	Qualifying remarks/Notes
4.3.3	ER 1 Seamless operation ER 3 Safety ER 4.1 Seamless operation of Communications systems and procedures for ground-to-ground, air-to-ground and air-to-air communications ER 4.2 Support for new concepts of operation for Communications systems and procedures for ground-to-ground, air-to-ground and air-to-air communications	
4.3.4	ER 1 Seamless operation ER 3 Safety ER 4.1 Seamless operation of Communications systems and procedures for ground-to-ground, air-to-ground and air-to-air communications ER 4.2 Support for new concepts of operation for Communications systems and procedures for ground-to-ground, air-to-ground and air-to-air communications	
4.3.5	ER 1 Seamless operation ER 3 Safety ER 4.1 Seamless operation of Communications systems and procedures for ground-to-ground, air-to-ground and air-to-air communications ER 4.2 Support for new concepts of operation for Communications systems and procedures for ground-to-ground, air-to-ground and air-to-air communications	
4.3.6	ER 1 Seamless operation ER 3 Safety ER 4.1 Seamless operation of Communications systems and procedures for ground-to-ground, air-to-ground and air-to-air communications ER 4.2 Support for new concepts of operation for Communications systems and procedures for ground-to-ground, air-to-ground and air-to-air communications	
4.3.7	ER 1 Seamless operation ER 3 Safety ER 4.1 Seamless operation of Communications systems and procedures for ground-to-ground, air-to-ground and air-to-air communications ER 4.2 Support for new concepts of operation for Communications systems and procedures for ground-to-ground, air-to-ground and air-to-air communications	

Clause(s) of the present document	(Essential) Requirements (ERs) of SES Interoperability Regulation (as amended), Annex II, Parts A and B	Qualifying remarks/Notes
4.3.8	ER 1 Seamless operation ER 3 Safety ER 4.1 Seamless operation of Communications systems and procedures for ground-to-ground, air-to-ground and air-to-air communications ER 4.2 Support for new concepts of operation for Communications systems and procedures for ground-to-ground, air-to-ground and air-to-air communications	
5.1	Void	
5.2	Void	
5.3.1	ER 1 Seamless operation ER 3 Safety ER 4.1 Seamless operation of Communications systems and procedures for ground-to-ground, air-to-ground and air-to-air communications ER 4.2 Support for new concepts of operation for Communications systems and procedures for ground-to-ground, air-to-ground and air-to-air communications	
5.3.2.1	ER 1 Seamless operation ER 3 Safety ER 4.1 Seamless operation of Communications systems and procedures for ground-to-ground, air-to-ground and air-to-air communications ER 4.2 Support for new concepts of operation for Communications systems and procedures for ground-to-ground, air-to-ground and air-to-air communications	
5.3.2.2	ER 1 Seamless operation ER 3 Safety ER 4.1 Seamless operation of Communications systems and procedures for ground-to-ground, air-to-ground and air-to-air communications ER 4.2 Support for new concepts of operation for Communications systems and procedures for ground-to-ground, air-to-ground and air-to-air communications	
5.3.3	ER 1 Seamless operation ER 3 Safety ER 4.1 Seamless operation of Communications systems and procedures for ground-to-ground, air-to-ground and air-to-air communications ER 4.2 Support for new concepts of operation for Communications systems and procedures for ground-to-ground, air-to-ground and air-to-air communications	

Clause(s) of the present document	(Essential) Requirements (ERs) of SES Interoperability Regulation (as amended), Annex II, Parts A and B	Qualifying remarks/Notes
5.3.4	ER 1 Seamless operation ER 3 Safety ER 4.1 Seamless operation of Communications systems and procedures for ground-to-ground, air-to-ground and air-to-air communications ER 4.2 Support for new concepts of operation for Communications systems and procedures for ground-to-ground, air-to-ground and air-to-air communications	
5.3.5	ER 1 Seamless operation ER 3 Safety ER 4.1 Seamless operation of Communications systems and procedures for ground-to-ground, air-to-ground and air-to-air communications ER 4.2 Support for new concepts of operation for Communications systems and procedures for ground-to-ground, air-to-ground and air-to-air communications	
5.4	ER 1 Seamless operation ER 3 Safety ER 4.1 Seamless operation of Communications systems and procedures for ground-to-ground, air-to-ground and air-to-air communications ER 4.2 Support for new concepts of operation for Communications systems and procedures for ground-to-ground, air-to-ground and air-to-air communications	
6.1	ER 1 Seamless operation ER 2 Support for new concepts of operation ER 3 Safety ER 4.1 Seamless operation of Communications systems and procedures for ground-to-ground, air-to-ground and air-to-air communications ER 4.2 Support for new concepts of operation for Communications systems and procedures for ground-to-ground, air-to-ground and air-to-air communications	
6.2	ER 1 Seamless operation ER 2 Support for new concepts of operation ER 3 Safety ER 4.1 Seamless operation of Communications systems and procedures for ground-to-ground, air-to-ground and air-to-air communications ER 4.2 Support for new concepts of operation for Communications systems and procedures for ground-to-ground, air-to-ground and air-to-air communications	

Clause(s) of the present document	(Essential) Requirements (ERs) of SES Interoperability Regulation (as amended), Annex II, Parts A and B	Qualifying remarks/Notes
6.3	ER 1 Seamless operation ER 2 Support for new concepts of operation ER 3 Safety ER 4.1 Seamless operation of Communications systems and procedures for ground-to-ground, air-to-ground and air-to-air communications ER 4.2 Support for new concepts of operation for Communications systems and procedures for ground-to-ground, air-to-ground and air-to-air communications	
6.4	ER 1 Seamless operation ER 2 Support for new concepts of operation ER 3 Safety ER 4.1 Seamless operation of Communications systems and procedures for ground-to-ground, air-to-ground and air-to-air communications ER 4.2 Support for new concepts of operation for Communications systems and procedures for ground-to-ground, air-to-ground and air-to-air communications	
6.5	ER 1 Seamless operation ER 2 Support for new concepts of operation ER 3 Safety ER 4.1 Seamless operation of Communications systems and procedures for ground-to-ground, air-to-ground and air-to-air communications ER 4.2 Support for new concepts of operation for Communications systems and procedures for ground-to-ground, air-to-ground and air-to-air communications	

NOTE: Other requirements and other EU Regulations and/or Directives may be applicable to the product(s) falling within the scope of the present document.



---

## Annex SB (normative): Standards Annex

The present annex provides a relationship between the present document and the Requirements of the Commission Regulation laying down requirements on data link services for the single European sky (as corrected) [i.2].

The ground implementation of data link services, derived from the ICAO standard Context Management (CM) and Controller Pilot Data Link Communication (CPDLC) applications shall comply with the Requirements of the Commission Regulation laying down requirements on data link services for the single European sky (as corrected) [i.2] as defined and described in the traceability matrixes of the present annex (tables SB.1 and SB.2 below).

## SB.1 Correspondence between this European Standard and Commission Regulation laying down requirements on data link services for the single European sky (as corrected) [i.2] for the ground implementation of data link services, derived from the ICAO standard Context Management (CM) and Controller Pilot Data Link Communication (CPDLC) applications

**Table SB.1: Traceability from Commission Regulation laying down requirements on data link services for the single European sky (as corrected) [i.2] to clauses of the present document**

Requirements from [i.2]	Clause(s) of the present document	Qualifying remarks/Notes
Article 1.1	Out of scope of the present document	
Article 1.2 (a)	4.1.2 Unconditional Constituent - ATM Data Processing 4.1.4 Unconditional Constituent - Ground Display (HMI) 4.3 Associated Procedures 5 System Testing	
Article 1.2 (b)	Out of scope of the present document	
Article 1.2 (c)	4.1.6 Conditional Constituent - VDL Mode 2 ground communications equipment 5.4 Test with real aircraft	Airborne-Equipment is out of scope of the present document
Article 1.3	Out of scope of the present document	
Article 1.4	Out of scope of the present document	
Article 2	3.1 Definitions	
Article 3	Out of scope of the present document	
Article 4 (a)	4.3 Associated Procedures 4.2.3.1 DLIC 5.4 Test with real aircraft 5.3.1 Test for CM Application 5.3.2.1 Test for CPDLC Connection Handling 6 Conformity Assessment materials	
Article 4 (b)	4.3 Associated Procedures 6 Conformity Assessment materials	
Article 4 (c)	6 Conformity Assessment materials	
Article 4 (d)	6 Conformity Assessment materials	
Article 4 (e)	6 Conformity Assessment materials	
Article 4 (f)	Out of scope of the present document	
Article 5.1	See annexes III.2 and III.3 of the present table	
Article 5.2	See annex IV.1 of the present table	
Article 5.3	Out of scope of the present document	
Article 5.4	Out of scope of the present document	
Article 5.5	Out of scope of the present document	
Article 5.6	Out of scope of the present document	
Article 6	Out of scope of the present document	
Article 7	Out of scope of the present document	
Article 8	Out of scope of the present document	
Article 9	See Annex IV, part B of this table	
Article 10	Out of scope of the present document	
Article 11	Out of scope of the present document	
Article 12	Out of scope of the present document	

Requirements from [i.2]	Clause(s) of the present document	Qualifying remarks/Notes
Article 13.1	4.1.3 Unconditional Constituent - Ground Data Recording equipment	
Article 13.2	4.1.3 Unconditional Constituent - Ground Data Recording equipment	
Article 13.3	Out of scope of the present document	
Article 13.4	Out of scope of the present document	
Article 13.5	Out of scope of the present document	
Article 13.6	Out of scope of the present document	
Article 13.7	Out of scope of the present document	
Article 13.8	Out of scope of the present document	
Article 14	Out of scope of the present document	
Article 15	Out of scope of the present document	
Annex I	Out of scope of the present document	
Annex II.1	4.2.3.1 DLIC 4.2.3.1.1.5 EUROCONTROL DLS Specification, clause A.2.5.7 4.2.3.1.2 Specific Performance Requirements 4.2.3.1.3 Specific Safety Requirements 4.3.7 Eurocontrol DLS Specification, clause C.2.6.4 5.3 Test configuration with simulator 5.3.1 Test for CM Application	
Annex II.2	4.2.3.2 ACM 4.2.3.2.4 Specific Performance Requirements 4.2.3.2.5 Specific Safety Requirements 4.3.7 Eurocontrol DLS Specification, clause C.2.6.4 5.3.2 Test for CPDLC Application 5.3 Test configuration with simulator 5.3.5 ACM Service	
Annex II.3	4.2.3.3 ACL 4.2.3.3.7 Specific Safety Requirements 4.3.3 Eurocontrol DLS Specification, clause C.2.2.4 4.3.4 Eurocontrol DLS Specification, clause C.2.2.6 5.3.2 Test for CPDLC Application 5.3.3 ACL Service 5.4 Test with real aircraft 4.2.3.3.6 Specific Performance Requirements 6 Conformity Assessment Material	
Annex II.4	4.2.3.4 AMC 4.2.3.4.4 Specific Performance Requirements 4.2.3.4.5 Specific Safety Requirements 4.3.3 Eurocontrol DLS Specification, clause C.2.2.4 5.3.4 AMC Service 6 Conformity Assessment Material	
Annex III.1	Out of scope of the present document	
Annex III.2	4.2.3.1 DLIC 5.3.1 Test for CM Application 5.4 Test with real aircraft	
Annex III.3	4.2.3.2 ACM 4.2.3.3 ACL 4.2.3.4 AMC 5.3.2 Test for CPDLC Application 5.3.3 ACL Service 5.3.4 AMC Service 5.3.5 ACM Service 5.4 Test with real aircraft	

Requirements from [i.2]	Clause(s) of the present document	Qualifying remarks/Notes
Annex III.4	4.1.1.2 Eurocontrol DLS Specification, clause B.2.1.2 4.1.2.12 Eurocontrol DLS Specification, clause B.2.4.8 4.1.2.13 Eurocontrol DLS Specification, clause B.2.1.2 4.1.2.20 Eurocontrol DLS Specification, clause B.2.4.1 4.1.5.1 Eurocontrol DLS Specification, clause B.2.1.2 4.1.1.4 Eurocontrol DLS Specification, clause B.2.5.1 4.1.1.5 Eurocontrol DLS Specification, clause B.2.5.5 4.1.2.25 Eurocontrol DLS Specification, clause B.2.5.1 4.1.2.27 Eurocontrol DLS Specification, clause B.2.5.5 4.1.5.3 Eurocontrol DLS Specification, clause B.2.5.1 4.1.5.5 Eurocontrol DLS Specification, clause B.2.5.5	
Annex III.5	4.1.6 Conditional Constituent - VDL Mode 2 ground communications equipment	
Annex III.6	4.1.3 Unconditional Constituent - Ground Data Recording equipment	
Annex III.7	Out of scope of the present document	
Annex III.8	Out of scope of the present document	
Annex III.9	4.1.3 Unconditional Constituent - Ground Data Recording equipment	
Annex III.10	Out of scope of the present document	
Annex III.11	4.2.1 Performance Requirements 4.2.2 Safety Requirements 4.2.3.1.2 Specific Performance Requirements 4.2.3.1.3 Specific Safety Requirements 4.2.3.2.4 Specific Performance Requirements 4.2.3.2.5 Specific Safety Requirements 4.2.3.3.6 Specific Performance Requirements 4.2.3.3.7 Specific Safety Requirements 4.2.3.4.4 Specific Performance Requirements 4.2.3.4.5 Specific Safety Requirements	
Annex IV, part A.1	4.2.3.1.1 Specific Interoperability Requirements 4.2.3.2.1 Specific Interoperability Requirements 4.2.3.3.1 Specific Interoperability Requirements 4.2.3.4.1 Specific Interoperability Requirements 5.4 Test with real aircraft	
Annex IV, part A.2	4.2.3.1 DLIC 4.2.3.2 ACM 4.2.3.3 ACL 4.2.3.4 AMC 5.3 Test configuration with simulator 5.4 Test with real aircraft	
Annex IV, part A.3	4.1.2.14 Eurocontrol DLS Specification, clause B.2.2.1 4.2.3.2.5 Specific Safety Requirements 4.2.3.3.7 Specific Safety Requirements 4.2.3.4.5 Specific Safety Requirements 5.4 Test with real aircraft	

Requirements from [i.2]	Clause(s) of the present document	Qualifying remarks/Notes
Annex IV, part B.1	4.2.3.1 DLIC 4.2.3.2 ACM 4.2.3.3 ACL 4.2.3.4 AMC 5.4 Test with real aircraft	
Annex IV, part B.2	4.2.1 Performance Requirements 4.2.3.1.2 Specific Performance Requirements 4.2.3.2.4 Specific Performance Requirements 4.2.3.3.6 Specific performance Requirements 4.2.3.4.4 Specific Performance Requirements 4.2.2 Safety Requirements 4.2.3.1.3 Specific Safety Requirements 4.2.3.2.5 Specific Safety Requirements 4.2.3.3.7 Specific Safety Requirements 4.2.3.4.5 Specific Safety Requirements	
Annex IV, part B.3	4.3.6 Eurocontrol DLS Specification, clause C.2.6.3 4.3.7 Eurocontrol DLS Specification, clause C.2.6.4	
Annex IV, part B.4	4.1.1.1 Eurocontrol DLS Specification, clause B.2.1.1 4.1.1.3 Eurocontrol DLS Specification, clause B.2.1.3 4.1.1.4 Eurocontrol DLS Specification, clause B.2.5.1 4.1.1.5 Eurocontrol DLS Specification, clause B.2.5.5 4.1.2.11 Eurocontrol DLS Specification, clause B.2.1.3 4.1.2.12 Eurocontrol DLS Specification, clause B.2.4.8 4.1.2.15 Eurocontrol DLS Specification, clause B.2.2.2 4.1.2.20 Eurocontrol DLS Specification, clause B.2.4.1 4.1.2.21 Eurocontrol DLS Specification, clause B.2.4.2 4.1.2.23 Eurocontrol DLS Specification, clause B.2.4.5 4.1.5.2 Eurocontrol DLS Specification, clause B.2.1.3	
Annex IV, part B.5	4.1.3 Unconditional Constituent - Ground Data Recording equipment	
Annex IV, part C	Out of scope of the present document	
Annex IV, part D	Out of scope of the present document	
Annex V	Out of scope of the present document	
Annex VI	Out of scope of the present document	
Annex VII, part A	Out of scope of the present document	
Annex VII, part B	Out of scope of the present document	

**Table SB.2: Traceability from clauses of the present document to Commission Regulation laying down requirements on data link services for the single European sky (as corrected) [i.2]**

Clause(s) of the present document	Regulation 29/2009 (as corrected)	Qualifying remarks/Notes
4.0		
4.1.1.1	Annex IV, part B.4	
4.1.1.2	Annex III.4	
4.1.1.3	Annex IV, part B.4	
4.1.1.4	Annex III.4 Annex IV, part B.4	
4.1.1.5	Annex III.4 Annex IV, part B.4	
4.1.1.6		
4.1.2.1	Article 1.2 (a)	
4.1.2.2	Article 1.2 (a)	
4.1.2.3	Article 1.2 (a)	
4.1.2.4	Void	
4.1.2.5	Article 1.2 (a)	
4.1.2.6	Article 1.2 (a)	
4.1.2.7	Article 1.2 (a)	
4.1.2.8	Article 1.2 (a)	
4.1.2.9	Article 1.2 (a)	
4.1.2.10	Article 1.2 (a)	
4.1.2.11	Article 1.2 (a) Annex IV, part B.4	
4.1.2.12	Article 1.2 (a) Annex III.4 Annex IV, part B.4	
4.1.2.13	Article 1.2 (a) Annex III.4	
4.1.2.14	Article 1.2 (a)	
4.1.2.15	Article 1.2 (a) Annex IV, part B.4	
4.1.2.16	Article 1.2 (a)	
4.1.2.17	Article 1.2 (a)	
4.1.2.18	Article 1.2 (a)	
4.1.2.19	Article 1.2 (a)	
4.1.2.20	Article 1.2 (a) Annex III.4 Annex IV, part B.4	
4.1.2.21	Article 1.2 (a) Annex IV, part B.4	
4.1.2.22	Article 1.2 (a)	
4.1.2.23	Article 1.2 (a) Annex IV, part B.4	
4.1.2.24	Article 1.2 (a)	
4.1.2.25	Article 1.2 (a) Annex III.4	
4.1.2.26	Article 1.2 (a)	
4.1.2.27	Article 1.2 (a) Annex III.4	
4.1.2.28	Void	
4.1.2.29	Void	
4.1.2.30	Void	
4.1.2.31	Article 1.2 (a)	
4.1.2.32	Void	
4.1.2.33	Article 1.2 (a)	
4.1.3	Article 13.1 Article 13.2 Annex III.6 Annex III.9 Annex IV, part B.5	
4.1.4.1	Article 1.2 (a)	
4.1.4.2	Article 1.2 (a)	
4.1.5.1	Annex III.4	
4.1.5.2	Annex IV, part B.4	

Clause(s) of the present document	Regulation 29/2009 (as corrected)	Qualifying remarks/Notes
4.1.5.3	Annex III.4	
4.1.5.4		
4.1.5.5	Annex III.4	
4.1.5.6		
4.1.6.1.1	Article 1.2 (c) Annex III.5	Airborne equipment is out of scope of the present document
4.1.6.2.1	Article 1.2 (c) Annex III.5	Airborne equipment is out of scope of the present document
4.1.6.2.2	Article 1.2 (c) Annex III.5	Airborne equipment is out of scope of the present document
4.1.6.2.3	Article 1.2 (c) Annex III.5	Airborne equipment is out of scope of the present document
4.1.6.3	Article 1.2 (c) Annex III.5	Airborne equipment is out of scope of the present document
4.1.6.4	Article 1.2 (c) Annex III.5	Airborne equipment is out of scope of the present document
4.2.1	Annex III.11 Annex IV, part B.2	
4.2.2	Annex III.11 Annex IV, part B.2	
4.2.3.1.1.1	Article 4 (a) Annex II.1 Annex III.2 Annex IV, part A.1 Annex IV, part A.2 Annex IV, part B.1	
4.2.3.1.1.2	Article 4 (a) Annex II.1 Annex III.2 Annex IV, part A.1 Annex IV, part A.2 Annex IV, part B.1	
4.2.3.1.1.3	Article 4 (a) Annex II.1 Annex III.2 Annex IV, part A.1 Annex IV, part A.2 Annex IV, part B.1	
4.2.3.1.1.4	Article 4 (a) Annex II.1 Annex III.2 Annex IV, part A.1 Annex IV, part A.2 Annex IV, part B.1	
4.2.3.1.1.5	Article 4 (a) Annex II.1 Annex III.2 Annex IV, part A.1 Annex IV, part A.2 Annex IV, part B.1	
4.2.3.1.1.6	Article 4 (a) Annex II.1 Annex III.2 Annex IV, part A.1 Annex IV, part A.2 Annex IV, part B.1	
4.2.3.1.2	Annex II.1 Annex III.11 Annex IV, part A.2 Annex IV, part B.1 Annex IV, part B.2	
4.2.3.1.3	Annex II.1 Annex III.11 Annex IV, part A.2 Annex IV, part B.1 Annex IV, part B.2	

Clause(s) of the present document	Regulation 29/2009 (as corrected)	Qualifying remarks/Notes
4.2.3.2.1.1	Annex II.2 Annex III.3 Annex IV, part A.1 Annex IV, part A.2 Annex IV, part B.1	
4.2.3.2.1.2	Annex II.2 Annex III.3 Annex IV, part A.1 Annex IV, part A.2 Annex IV, part B.1	
4.2.3.2.1.3	Annex II.2 Annex III.3 Annex IV, part A.1 Annex IV, part A.2 Annex IV, part B.1	
4.2.3.2.1.4	Annex II.2 Annex III.3 Annex IV, part A.1 Annex IV, part A.2 Annex IV, part B.1	
4.2.3.2.2.1	Annex II.2 Annex III.3 Annex IV, part A.2 Annex IV, part B.1	
4.2.3.2.3	Annex II.2 Annex III.3 Annex IV, part A.2 Annex IV, part B.1	
4.2.3.2.4	Annex II.2 Annex III.3 Annex III.11 Annex IV, part A.2 Annex IV, part B.1 Annex IV, part B.2	
4.2.3.2.5	Annex II.2 Annex III.3 Annex III.11 Annex IV, part A.2 Annex IV, part B.1 Annex IV, part B.2	
4.2.3.3.1	Annex II.3 Annex III.3 Annex IV, part A.1 Annex IV, part A.2 Annex IV, part B.1	
4.2.3.3.2	Annex II.3 Annex III.3 Annex IV, part A.2 Annex IV, part B.1	
4.2.3.3.3	Annex II.3 Annex III.3 Annex IV, part A.2 Annex IV, part B.1	
4.2.3.3.4	Void	
4.2.3.3.5	Void	
4.2.3.3.6	Annex II.3 Annex III.3 Annex III.11 Annex IV, part A.2 Annex IV, part B.1 Annex IV, part B.2	
4.2.3.3.7.1	Annex II.3 Annex III.3 Annex III.11 Annex IV, part A.2 Annex IV, part B.1 Annex IV, part B.2	



Clause(s) of the present document	Regulation 29/2009 (as corrected)	Qualifying remarks/Notes
4.2.3.4.1	Annex II.4 Annex III.3 Annex IV, part A.1 Annex IV, part A.2 Annex IV, part B.1	
4.2.3.4.2	Annex II.4 Annex III.3 Annex IV, part A.2 Annex IV, part B.1	
4.2.3.4.3	Annex II.4 Annex III.3 Annex IV, part A.2 Annex IV, part B.1	
4.2.3.4.4	Annex II.4 Annex III.3 Annex III.11 Annex IV, part A.2 Annex IV, part B.1 Annex IV, part B.2	
4.2.3.4.5	Annex II.4 Annex III.3 Annex III.11 Annex IV, part A.2 Annex IV, part B.1 Annex IV, part B.2	
4.3.1	Article 1.2 (a) Article 4 (a) Article 4 (b)	
4.3.2	Void	
4.3.3	Article 1.2 (a) Article 4 (a) Article 4 (b) Annex II.3 Annex II.4	
4.3.4	Article 1.2 (a) Article 4 (a) Article 4 (b) Annex II.3	
4.3.5	Article 1.2 (a) Article 4 (a) Article 4 (b)	
4.3.6	Article 1.2 (a) Article 4 (a) Article 4 (b) Annex IV, part B.3	
4.3.7	Article 1.2 (a) Article 4 (a) Article 4 (b) Annex II.1 Annex II.2 Annex IV, part B.3	
4.3.8	Article 1.2 (a) Article 4 (a) Article 4 (b)	
5.1	Void	
5.2	Void	
5.3.1	Article 1.2 (a) Article 4 (a) Annex II.1 Annex II.2 Annex III.2 Annex IV, part A.2	

Clause(s) of the present document	Regulation 29/2009 (as corrected)	Qualifying remarks/Notes
5.3.2.1	Article 1.2 (a) Article 4 (a) Annex II.1 Annex II.2 Annex II.3 Annex III.3 Annex IV, part A.2	
5.3.2.2	Article 1.2 (a) Annex II.1 Annex II.2 Annex II.3 Annex III.3 Annex IV, part A.2	
5.3.3	Article 1.2 (a) Annex II.1 Annex II.2 Annex II.3 Annex III.3 Annex IV, part A.2	
5.3.4	Article 1.2 (a) Annex II.1 Annex II.2 Annex II.3 Annex II.4 Annex III.3 Annex IV, part A.2	
5.3.5	Article 1.2 (a) Annex II.1 Annex II.2 Annex III.3 Annex IV, part A.2	
5.4	Article 1.2 (c) Article 4 (a) Annex II.3 Annex III.2 Annex III.3 Annex IV, part A.1 Annex IV, part A.2 Annex IV, part B.1	
6.1	Article 4 (a) Article 4 (b) Article 4 (c) Article 4 (d) Article 4 (e) Annex II.3 Annex II.4	
6.2	Article 4 (a) Article 4 (b) Article 4 (c) Article 4 (d) Article 4 (e) Annex II.3 Annex II.4	
6.3	Article 4 (a) Article 4 (b) Article 4 (c) Article 4 (d) Article 4 (e) Annex II.3 Annex II.4	
6.4	Article 4 (a) Article 4 (b) Article 4 (c) Article 4 (d) Article 4 (e) Annex II.3 Annex II.4	

Clause(s) of the present document	Regulation 29/2009 (as corrected)	Qualifying remarks/Notes
6.5	Article 4 (a) Article 4 (b) Article 4 (c) Article 4 (d) Article 4 (e) Annex II.3 Annex II.4	

NOTE: Other requirements and other EU Regulations and/or Directives may be applicable to the product(s) falling within the scope of the present document.

## Annex A (normative): Checklist

The purpose of the present annex is to provide a comprehensive traceability of evidence on constituents and system levels against sub-clauses of the Essential Requirements (ERs) of the Interoperability Regulation [i.6], analyzing keywords of these same essential requirements.

These keywords mainly address the phases of design, build, operation and maintenance of systems and constituents as well as specifically required qualities or attributes as defined in the ERs of the SES Interoperability Regulation [i.6].

The ground implementation of data link services, derived from the ICAO standard Context Management (CM) and Controller Pilot Data Link Communication (CPDLC) applications shall comply with the Essential Requirements of the Interoperability Regulation [i.6] as defined and described in the tables of the present annex.

### A.1 Interoperability Regulation Annex II Essential Requirements; Part A: General requirements

Table A.1

1	<b>ER 1 seamless operation</b>		
	Regulation (EC) 552/2004 [i.6] as amended by Regulation (EC) 1070/2009 requires that: "Air traffic management systems and their constituents shall be designed, built, maintained and operated using the appropriate and validated procedures, in such a way as to ensure the seamless operation of the EATMN at all times and for all phases of flight. Seamless operation can be expressed, in particular, in terms of information sharing, including the relevant operational status information, common understanding of information, comparable processing performances and the associated procedures enabling common operational performances agreed for the whole or parts of the EATMN."		
	<b>Keywords</b>	<b>Evidence on constituent level</b>	<b>Evidence on system level</b>
1.1	Designed	n/a	<b>4.2</b> Design Requirements for DLS ground constituents <b>4.1.1</b> Unconditional Constituent - Ground Ground ATN Routers <b>4.1.2</b> Unconditional Constituent - ATM Data Processing <b>4.1.3</b> Unconditional Constituent - Ground Data Recording equipment <b>4.1.4</b> Unconditional Constituent - Ground Display (HMI) <b>4.1.5</b> Conditional Constituent - Air Ground ATN Routers <b>4.1.6</b> Conditional Constituent - VDL Mode 2 ground communications equipment
1.2	Built	n/a	<b>5</b> System Testing
1.3	Maintained	n/a	not covered by the present document

1	<b>ER 1 seamless operation</b>		
	Regulation (EC) 552/2004 [i.6] as amended by Regulation (EC) 1070/2009 requires that: "Air traffic management systems and their constituents shall be designed, built, maintained and operated using the appropriate and validated procedures, in such a way as to ensure the seamless operation of the EATMN at all times and for all phases of flight. Seamless operation can be expressed, in particular, in terms of information sharing, including the relevant operational status information, common understanding of information, comparable processing performances and the associated procedures enabling common operational performances agreed for the whole or parts of the EATMN."		
	<b>Keywords</b>	<b>Evidence on constituent level</b>	<b>Evidence on system level</b>
1.4	Operated	n/a	4.3 Associated Procedures 6 Conformity Assessment materials
1.5	information sharing	n/a	4.2.1 Performance Requirements 4.2.3.1.1 Specific Interoperability Requirements 4.2.3.1.2 Specific Performance Requirements 4.2.3.2.1 Specific Interoperability Requirements 4.2.3.2.4 Specific Performance Requirements 4.2.3.3.1 Specific Interoperability Requirements 4.2.3.3.6 Specific Performance Requirements 4.2.3.4.1 Specific Interoperability Requirements 4.2.3.4.4 Specific Performance Requirements 4.3 Associated Procedures

Table A.2

2	<b>ER 2 Support for new concepts of operation</b>		
	Regulation (EC) 552/2004 [i.6] as amended by Regulation (EC) 1070/2009 requires that: "The EATMN, its systems and their constituents shall support, on a coordinated basis, new agreed and validated concepts of operation that improve the quality, sustainability and effectiveness of air navigation services, in particular in terms of safety and capacity. The potential of new concepts, such as collaborative decision-making, increasing automation and alternative methods of delegation of separation responsibility, shall be examined taking due account of technological developments and of their safe implementation, following validation."		
	<b>Keywords</b>	<b>Evidence on constituent level</b>	<b>Evidence on system level</b>
2.1	Validated concepts of operation - safety	n/a	4.2.3.1.3 Specific Safety Requirements 4.2.3.2.5 Specific Safety Requirements 4.2.3.3.7 Specific Safety Requirements 4.2.2 Safety Requirements 4.2.3.4.5 Specific Safety Requirements 6 Conformity Assessment materials
2.2	Validated concepts of operation - capacity	n/a	6 Conformity Assessment materials
2.3	Validated concepts of operation - quality	n/a	4.2.3.1.2 Specific Performance Requirements 4.2.3.2.4 Specific Performance Requirements 4.2.3.3.6 Specific Performance Requirements 4.2.3.4.4 Specific Performance Requirements 4.2.1 Performance Requirements

Table A.3

3	<b>ER 3 Safety</b>			
	Regulation (EC) 552/2004 [i.6] as amended by Regulation (EC) 1070/2009 requires that: "Systems and operations of the EATMN shall achieve agreed high levels of safety. Agreed safety management and reporting methodologies shall be established to achieve this. In respect of appropriate ground-based systems, or parts thereof, these high levels of safety shall be enhanced by safety nets which shall be subject to agreed common performance characteristics. A harmonized set of safety requirements for the design, implementation, maintenance and operation of systems and their constituents, both for normal and degraded modes of operation, shall be defined with a view to achieving the agreed safety levels, for all phases of flight and for the entire EATMN. Systems shall be designed, built, maintained and operated, using the appropriate and validated procedures, in such a way that the tasks assigned to the control staff are compatible with human capabilities, in both the normal and degraded modes of operation, and are consistent with required safety levels. Systems shall be designed, built, maintained and operated using the appropriate and validated procedures, in such a way as to be free from harmful interference in their normal operational environment."			
	<b>Keywords</b>	<b>Evidence on constituent level</b>	<b>Evidence on system level</b>	<b>Evidence at procedure level</b>
3.1	Design	n/a	4.2.3.1.3 Specific Safety Requirements 4.2.3.2.5 Specific Safety Requirements 4.2.2 Safety Requirements 4.2.3.3.7 Specific Safety Requirements 4.2.3.4.5 Specific Safety Requirements	4.3 Associated Procedures
3.2	Implementation	n/a	5 System Testing	6 Conformity Assessment materials
3.3	Maintenance	n/a	not covered by the present document	not covered by the present document
3.4	Operation	n/a	not covered by the present document	6 Conformity Assessment materials
3.5	Human capabilities	n/a	4.1.4.1 Eurocontrol DLS Specification, clause A.2.1.5 4.1.4.2 Eurocontrol DLS Specification, clause A.2.1.6	n/a
3.6	Harmful interference	n/a	n/a	n/a

Table A.4

4	<b>ER 4 Civil-military coordination</b>		
	Regulation (EC) 552/2004 [i.6] as amended by Regulation (EC) 1070/2009 requires that: "The EATMN, its systems and their constituents shall support the progressive implementation of civil/military coordination, to the extent necessary for effective airspace and air traffic flow management, and the safe and efficient use of airspace by all users, through the application of the concept of the flexible use of airspace. To achieve these objectives, the EATMN, its systems and their constituents shall support the timely sharing of correct and consistent information covering all phases of flight, between civil and military parties. Account should be taken of national security requirements."		
	<b>Keywords</b>	<b>Evidence on constituent level</b>	<b>Evidence on system level</b>
4.1	Flexible use of airspace	n/a	not covered by the present document
4.2	Timely sharing	n/a	not covered by the present document
4.3	National security requirements	n/a	not covered by the present document

Table A.5

5	<b>ER 5 Environmental constraints</b>			
	Regulation (EC) 552/2004 [i.6] as amended by Regulation (EC) 1070/2009 requires that: "Systems and operations of the EATMN shall take into account the need to minimize environmental impact in accordance with Community legislation."			
	<b>Keywords</b>	<b>Evidence on constituent level</b>	<b>Evidence on system level</b>	<b>Evidence at procedure level</b>
5.1	Minimize environmental impact - ATS	n/a	not covered by the present document	not covered by the present document
5.2	Minimize environmental impact - materials	n/a	not covered by the present document	not covered by the present document

Table A.6

6	<b>ER 6 Principles governing the logical architecture of systems</b>		
	Regulation (EC) 552/2004 [i.6] as amended by Regulation (EC) 1070/2009 requires that: "Systems shall be designed and progressively integrated with the objective of achieving a coherent and increasingly harmonized, evolutionary and validated logical architecture within the EATMN."		
	<b>Keywords</b>	<b>Evidence on constituent level</b>	<b>Evidence on system level</b>
6.1	Designed and progressively integrated.	n/a	4.1 Constituents of a DLS System 5 System Testing

Table A.7

7	<b>ER 7 Principles governing the construction of systems</b> Regulation (EC) 552/2004 [i.6] as amended by Regulation (EC) 1070/2009 requires that: "Systems shall be designed, built and maintained on the grounds of sound engineering principles, in particular those relating to modularity, enabling interchangeability of constituents, high availability, and redundancy and fault tolerance of critical constituents."		
	<b>Keywords</b>	<b>Evidence on constituent level</b>	<b>Evidence on system level</b>
7.1	Modularity, interchangeability.	n/a	4.1 Constituents of a DLS System (modularity) 4.1.1.1 Eurocontrol DLS Specification, clause B.2.1.1 (interchangeability at the interface between ATSP-domain) 4.1.6 Conditional Constituent - VDL Mode 2 ground communications equipment (CSP-domain and airborne domain)
7.2	High availability, Redundancy and fault tolerance.	n/a	4.2.1 Performance Requirements 4.2.3.1.2 Specific Performance Requirements 4.2.3.2.4 Specific Performance Requirements 4.2.3.3.6 Specific Performance Requirements 4.2.3.4.4 Specific Performance Requirements

## A.2 Interoperability Regulation Annex II Essential Requirements; Part B: Specific requirements

### A.2.1 Systems and procedures for airspace management

Table A.8

1.1	<b>ER 1.1 Seamless operation</b> Regulation (EC) 552/2004 [i.6] as amended by Regulation (EC) 1070/2009 requires that: "Information relating to pre-tactical and tactical aspects of airspace availability shall be provided to all interested parties in a correct and timely way so as to ensure an efficient allocation and use of airspace by all airspace users. This should take into account national security requirements."		
	<b>Keywords</b>	<b>Evidence on constituent level</b>	<b>Evidence on system level</b>
1.1.1	Modularity, interchangeability	n/a	n/a
1.1.2	High availability	n/a	n/a
1.1.3	Redundancy and fault tolerance	n/a	n/a

### A.2.2 Systems and procedures for air traffic flow management

Table A.9

2.1	<b>ER 2.1 Seamless operation</b> Regulation (EC) 552/2004 [i.6] as amended by Regulation (EC) 1070/2009 requires that: "Systems and procedures for air traffic flow management shall support the sharing of correct, coherent and relevant strategic, pre-tactical and tactical, as applicable, flight information covering all phases of flight and offer dialogue capabilities with a view to achieving optimized use of airspace."			
	<b>Keywords</b>	<b>Evidence on constituent level</b>	<b>Evidence on system level</b>	<b>Evidence at procedure level</b>
2.1.1	Strategic	n/a	n/a	n/a
2.1.2	Pre-tactical	n/a	n/a	n/a
2.1.3	Tactical	n/a	n/a	n/a



## A.2.3 Systems and procedures for air traffic services

### A.2.3.1 Flight data processing systems

Table A.10

3.1.1	<b>ER 3.1.1 Seamless operation</b>		
	Regulation (EC) 552/2004 [i.6] as amended by Regulation (EC) 1070/2009 requires that: "Flight data processing systems shall be interoperable in terms of the timely sharing of correct and consistent information, and a common operational understanding of that information, in order to ensure a coherent and consistent planning process and resource-efficient tactical coordination throughout the EATMN during all phases of flight. In order to ensure safe, smooth and expeditious processing throughout the EATMN, flight data processing performances shall be equivalent and appropriate for a given environment (surface, terminal manoeuvring area (TMA), en-route), with known traffic characteristics and exploited under an agreed and validated operational concept, in particular in terms of accuracy and error tolerance of processing results."		
	<b>Keywords</b>	<b>Evidence on constituent level</b>	<b>Evidence on system level</b>
3.1.1.1	Timely sharing	n/a	not covered by the present document
3.1.1.2	Performance appropriate for environment	n/a	not covered by the present document
3.1.1.3	Accuracy and error tolerance	n/a	not covered by the present document

Table A.11

3.1.2	<b>ER 3.1.2. Support for new concepts of operation</b>		
	Regulation (EC) 552/2004 [i.6] as amended by Regulation (EC) 1070/2009 requires that: "Flight data processing systems shall accommodate the progressive implementation of advanced, agreed and validated concepts of operation for all phases of flight, in particular as envisaged in the ATM Master Plan. The characteristics of automation-intensive tools must be such as to enable coherent and efficient pre-tactical and tactical processing of flight information in parts of the EATMN. Airborne and ground systems and their constituents supporting new, agreed and validated concepts of operation shall be designed, built, maintained and operated, using appropriate and validated procedures, in such a way as to be interoperable in terms of timely sharing of correct and consistent information and a common understanding of the current and predicted operational situation."		
	<b>Keywords</b>	<b>Evidence on constituent level</b>	<b>Evidence on system level</b>
3.1.2.1	Airborne systems - design	n/a	n/a
3.1.2.2	Airborne systems - built	n/a	n/a
3.1.2.3	Airborne systems - maintained	n/a	n/a
3.1.2.4	Airborne systems - operated	n/a	n/a
3.1.2.5	Ground systems - design	n/a	not covered by the present document
3.1.2.6	Ground systems - built	n/a	not covered by the present document
3.1.2.7	Ground systems - maintained	n/a	not covered by the present document
3.1.2.8	Ground systems - operated	n/a	not covered by the present document

### A.2.3.2 Surveillance data processing systems

Table A.12

3.2.1	<b>ER 3.2.1 Seamless operation</b>		
	Regulation (EC) 552/2004 [i.6] as amended by Regulation (EC) 1070/2009 requires that: "Surveillance data processing systems shall be designed, built, maintained and operated using the appropriate and validated procedures, in such a way as to provide the required performance and quality of service within a given environment (surface, TMA, en-route) with known traffic characteristics, in particular in terms of accuracy and reliability of computed results, correctness, integrity, availability, continuity and timeliness of information at the control position. Surveillance data processing systems shall accommodate the timely sharing of relevant, accurate, consistent and coherent information between them to ensure optimized operations through different parts of the EATMN."		
	<b>Keywords</b>	<b>Evidence on constituent level</b>	<b>Evidence on system level</b>
3.2.1.1	Designed	n/a	n/a
3.2.1.2	Built	n/a	n/a
3.2.1.3	Maintained	n/a	n/a
3.2.1.4	Operated	n/a	n/a

Table A.13

3.2.2	<b>ER 3.2.2. Support for new concepts of operation</b>		
	Regulation (EC) 552/2004 [i.6] as amended by Regulation (EC) 1070/2009 requires that: "Surveillance data processing systems shall accommodate the progressive availability of new sources of surveillance information in such a way as to improve the overall quality of service, in particular as envisaged in the ATM Master Plan."		
	<b>Keywords</b>	<b>Evidence on constituent level</b>	<b>Evidence on system level</b>
3.2.2.1	Availability of new sources	n/a	n/a

### A.2.3.3 Human-machine interface systems

Table A.14

3.3.1	<b>ER 3.3.1 Seamless operation</b>		
	Regulation (EC) 552/2004 [i.6] as amended by Regulation (EC) 1070/2009 requires that: "Human-machine interfaces of ground air traffic management systems shall be designed, built, maintained and operated using the appropriate and validated procedures, in such a way as to offer to all control staff a progressively harmonized working environment, including functions and ergonomics, meeting the required performance for a given environment (surface, TMA, en-route), with known traffic characteristics."		
	<b>Keywords</b>	<b>Evidence on constituent level</b>	<b>Evidence on system level</b>
3.3.1.1	Designed	n/a	<b>4.1.4</b> Unconditional Constituent - Ground Display (HMI) (as far as DL is concerned)
3.3.1.2	Built	n/a	not covered by the present document
3.3.1.3	Maintained	n/a	not covered by the present document
3.3.1.4	Operated	n/a	not covered by the present document

Table A.15

3.3.2	<b>ER 3.3.2. Support for new concepts of operation</b>		
	Regulation (EC) 552/2004 [i.6] as amended by Regulation (EC) 1070/2009 requires that: "Human-machine interface systems shall accommodate the progressive introduction of new, agreed and validated concepts of operation and increased automation, in such a way as to ensure that the tasks assigned to the control staff remain compatible with human capabilities, in both the normal and degraded modes of operation."		
	<b>Keywords</b>	<b>Evidence on constituent level</b>	<b>Evidence on system level</b>
3.3.2.1	Human capabilities	n/a	<b>4.1.4</b> Unconditional Constituent - Ground Display (HMI) (as far as DL is concerned)

## A.2.4 Communications systems and procedures for ground-to-ground, air-to-ground and air-to-air communications

Table A.16

4.1	<b>ER 4.1 Seamless operation</b>		
	Regulation (EC) 552/2004 [i.6] as amended by Regulation (EC) 1070/2009 requires that: "Communication systems shall be designed, built, maintained and operated using the appropriate and validated procedures, in such a way as to achieve the required performances within a given volume of airspace or for a specific application, in particular in terms of communication processing time, integrity, availability and continuity of function. The communications network within the EATMN shall be such as to meet the requirements of quality of service, coverage and redundancy."		
	<b>Keywords</b>	<b>Evidence on constituent level</b>	<b>Evidence on system level</b>
4.1.1	Designed	n/a	4 Requirements for implementing Data Link Services
4.1.2	Built	n/a	5 System Testing
4.1.3	Maintained	n/a	n/a
4.1.4	Operated	n/a	6 Conformity Assessment materials
4.1.5	Quality of service, coverage, redundancy	n/a	4.2.1 Performance Requirements 4.2.3.1.2 Specific Performance Requirements 4.2.3.2.4 Specific Performance Requirements 4.2.3.3.6 Specific Performance Requirements 4.2.3.4.4 Specific Performance Requirements

Table A.17

4.2	<b>ER 4.2 Support for new concepts of operation</b>		
	Regulation (EC) 552/2004 [i.6] as amended by Regulation (EC) 1070/2009 requires that: "Communication systems shall support the implementation of advanced, agreed and validated concepts of operation for all phases of flight, in particular as envisaged in the ATM Master Plan."		
	<b>Keywords</b>	<b>Evidence on constituent level</b>	<b>Evidence on system level</b>
4.2.1	Support the implementation	n/a	4 Requirements for implementing Data Link Services 5 System Testing 6 Conformity Assessment materials

## A.2.5 Navigation systems and procedures

Table A.18

5.1	<b>ER 5.1 Seamless operation</b>		
	Regulation (EC) 552/2004 [i.6] as amended by Regulation (EC) 1070/2009 requires that: "Navigation systems shall be designed, built, maintained and operated using appropriate and validated procedures in such a way as to achieve the required horizontal and vertical navigation performance, in particular in terms of accuracy and functional capability, for a given environment (surface, TMA, en-route), with known traffic characteristics and exploited under an agreed and validated operational concept."		
	<b>Keywords</b>	<b>Evidence on constituent level</b>	<b>Evidence on system level</b>
5.1.1	Designed	n/a	n/a
5.1.2	Built	n/a	n/a
5.1.3	Maintained	n/a	n/a
5.1.4	Operated	n/a	n/a

## A.2.6 Surveillance systems and procedures

Table A.19

6.1	<b>ER 6.1 Seamless operation</b>		
	Regulation (EC) 552/2004 [i.6] as amended by Regulation (EC) 1070/2009 requires that: "Surveillance systems shall be designed, built, maintained and operated using appropriate and validated procedures in such a way as to provide the required performance applicable in a given environment (surface, TMA, en-route) with known traffic characteristics and exploited under an agreed and validated operational concept, in particular in terms of accuracy, coverage, range and quality of service. The surveillance network within the EATMN shall be such as to meet the requirements of accuracy, timeliness, coverage and redundancy. The surveillance network shall enable surveillance data to be shared in order to enhance operations throughout the EATMN."		
	<b>Keywords</b>	<b>Evidence on constituent level</b>	<b>Evidence on system level</b>
6.1.1	Designed	n/a.	n/a.
6.1.2	Built	n/a.	n/a.
6.1.3	Maintained	n/a.	n/a.
6.1.4	Operated	n/a.	n/a.

## A.2.7 Systems and procedures for aeronautical information services

Table A.20

7.1	<b>ER 7.1 Seamless operation</b>		
	Regulation (EC) 552/2004 [i.6] as amended by Regulation (EC) 1070/2009 requires that: "Accurate, timely and consistent aeronautical information shall be provided progressively in an electronic form, based on a commonly agreed and standardized data set. Accurate and consistent aeronautical information, in particular concerning airborne and ground-based constituents or systems, shall be made available in a timely manner."		
	<b>Keywords</b>	<b>Evidence on constituent level</b>	<b>Evidence on system level</b>
7.1.1	Accurate, timely and consistent	n/a.	n/a.
7.1.2	Standardized data set	n/a.	n/a.

Table A.21

7.2	<b>ER 7.2 Support for new concepts of operation</b>		
	Regulation (EC) 552/2004 [i.6] as amended by Regulation (EC) 1070/2009 requires that: "Increasingly accurate, complete and up-to-date aeronautical information shall be made available and used in a timely manner in order to support continuous improvement of the efficiency of airspace and airport use."		
	<b>Keywords</b>	<b>Evidence on constituent level</b>	<b>Evidence on system level</b>
7.2.1	Increasingly accurate, complete and up-to-date	n/a.	n/a.

## A.2.8 Systems and procedures for the use of meteorological information

Table A.22

8.1	<b>ER 8.1 Seamless operation</b>			
	Regulation (EC) 552/2004 [i.6] as amended by Regulation (EC) 1070/2009 requires that: "Systems and procedures for the use of meteorological information shall improve the consistency and timeliness of its provision and the quality of its presentation, using an agreed data set."			
	<b>Keywords</b>	<b>Evidence on constituent level</b>	<b>Evidence on system level</b>	<b>Evidence at procedure level</b>
8.1.1	Consistency and timeliness	n/a.	n/a.	n/a.

Table A.23

8.2	<b>ER 8.2 Support for new concepts of operation</b>			
	Regulation (EC) 552/2004 [i.6] as amended by Regulation (EC) 1070/2009 requires that: "Systems and procedures for the use of meteorological information shall improve the promptness of its availability and the speed with which it may be used, in order to support continuous improvement of the efficiency of airspace and airport use."			
	<b>Keywords</b>	<b>Evidence on constituent level</b>	<b>Evidence on system level</b>	<b>Evidence at procedure level</b>
8.2.1	Promptness, speed	n/a.	n/a.	n/a.

---

## Annex B (normative): Requirements on Datalink-Service

The purpose of the present annex is to provide a comprehensive traceability of evidence on constituents and system levels against sub-clauses of the provisions on Datalink-Service Regulation (EC 29/2009) [i.2].

The ground implementation of data link services, derived from the ICAO standard Context Management (CM) and Controller Pilot Data Link Communication (CPDLC) applications shall comply with the provisions of the Datalink-Service Regulation as defined and described in the tables of the present annex.

NOTE: Each numbered Article of the Data Link Services Regulation is reproduced in the first two columns of the table below followed by a cross-reference to the corresponding paragraph in this CS DLS.

## B.1 Articles of the Datalink-Service Regulation (EC 29/2009)

### B.1.1 Article 1 Subject matter and scope

Table B.1

Ref. §	Regulation EC 29/2009 [i.2] (as corrected) requires that:	CS Ref. Evidence on constituent level	CS Ref. Evidence on system level	CS Ref. Evidence on procedures
1.	This Regulation lays down requirements for the coordinated introduction of data link services based on air-ground point-to-point data communications as defined in Article 2(5).	n/a	n/a	n/a
2.	This Regulation shall apply to:	n/a	n/a	n/a
(a)	flight data processing systems, their constituents and associated procedures, and human-machine interface systems, their constituents and associated procedures, serving air traffic control units providing services to general air traffic;	n/a	<b>4.1.2</b> Unconditional Constituent - ATM Data Processing  <b>4.1.4</b> Unconditional Constituent - Ground Display (HMI)  <b>5</b> System Testing	<b>4.3</b> Associated Procedures
(b)	airborne human-machine interface constituents and associated procedures;	Out of scope of the present document.	Out of scope of the present document.	Out of scope of the present document.
(c)	air-ground communication systems, their constituents and associated procedures.	Airborne-Equipment is out of scope of the present document	Airborne-Equipment is out of scope of the present document  <b>4.1.6</b> Conditional Constituent - VDL Mode 2 ground communications equipment <b>5.4</b> Test with real aircraft	Airborne-Equipment is out of scope of the present document
3.	This Regulation shall apply to all flights operating as general air traffic in accordance with instrument flight rules within the airspace above FL 285 defined in Annex I, Part A. In addition, it shall apply from 5 February 2015 to all flights operating as general air traffic in accordance with instrument flight rules within the airspace above FL 285 defined in Annex I, Part B.	n/a	n/a	n/a
4.	This Regulation shall apply to air traffic service providers (hereinafter ATS providers) providing services to general air traffic within the airspace referred to in paragraph 3 and in accordance with the relevant dates of application.	n/a	n/a	n/a

## B.1.2 Article 2 Definitions

All definitions are referred to in clause 3.1 of the present document.



## B.1.3 Article 3 Datalink services

Table B.2

Ref. §	Regulation EC 29/2009 [i.2] (as corrected) requires that:	CS Ref. Evidence on constituent level	CS Ref. Evidence on system level	CS Ref. Evidence on procedures
1.	ATS providers shall ensure that ATS units providing air traffic services within the airspace referred to in Article 1(3) have the capability to provide and operate the data link services defined in Annex II.	Out of scope of the present document.	n/a	n/a
2.	Without prejudice to paragraph 4 of this Article, operators shall ensure that aircraft operating flights referred to in Article 1(3) with an individual certificate of airworthiness first issued on or after 1 January 2011 have the capability to operate the data link services defined in Annex II.	Out of scope of the present document.	Out of scope of the present document.	Out of scope of the present document.
3.	Without prejudice to paragraph 4 of this Article, operators shall ensure that aircraft operating flights referred to in Article 1(3) with an individual certificate of airworthiness first issued before 1 January 2011 have the capability to operate the data link services defined in Annex II as from 5 February 2015.	Out of scope of the present document.	Out of scope of the present document.	Out of scope of the present document.
4.	Paragraphs 2 and 3 shall not apply to the following:			
(a)	aircraft with an individual certificate of airworthiness first issued before 1 January 2014 and fitted with data link equipment certified against the requirements of one of the Eurocae documents specified in point 10 of Annex III;	Out of scope of the present document.	Out of scope of the present document.	Out of scope of the present document.
(b)	aircraft which have an individual certificate of airworthiness first issued before 1 January 1998 and which will cease operation in the airspace referred to in Article 1(3) by 31 December 2017;	Out of scope of the present document.	Out of scope of the present document.	Out of scope of the present document.
(c)	State aircraft;	Out of scope of the present document.	Out of scope of the present document.	Out of scope of the present document.

Ref. §	Regulation EC 29/2009 [i.2] (as corrected) requires that:	CS Ref. Evidence on constituent level	CS Ref. Evidence on system level	CS Ref. Evidence on procedures
(d)	aircraft flying in the airspace referred to in Article 1(3) for testing, delivery or for maintenance purposes or with data link constituents temporarily inoperative under conditions specified in the applicable minimum equipment list required by point 1 of Annex III to this Regulation and by Regulation (EC) No 216/2008 and its implementing rules.	Out of scope of the present document.	Out of scope of the present document.	Out of scope of the present document.
5.	Member States which decide to equip new transport type State aircraft entering into service from 1 January 2014 with data link capability relying upon standards which are not specific to military operational requirements, shall ensure that those aircraft have the capability to operate the data link services defined in Annex II.	Out of scope of the present document.	Out of scope of the present document.	Out of scope of the present document.

## B.1.4 Article 4 Associated procedures

Table B.3

Ref. §	Regulation EC 29/2009 [i.2] (as corrected) requires that:	CS Ref. Evidence on constituent level	CS Ref. Evidence on system level	CS Ref. Evidence on procedures
	ATS providers providing air traffic services and operators using air traffic services supported by the data link services defined in Annex II shall apply common standardized procedures consistent with relevant provisions of the International Civil Aviation Organisation (hereinafter ICAO) for:			
a)	the establishment of controller - pilot data link communications (hereinafter CPDLC);	Out of scope of the present document.	6 Conformity Assessment materials	4.3 Associated Procedures 4.2.3.1 DLIC 5.4 Test with real aircraft 5.3.1 Test for CM Application 5.3.2.1 Test for CPDLC Connection Handling
b)	the exchange of operational CPDLC messages;	Out of scope of the present document.		4.3 Associated Procedures 6 Conformity Assessment materials
c)	the transfer of CPDLC;	Out of scope of the present document.	6 Conformity Assessment materials	
d)	the temporary discontinuation of the use of CPDLC pilot requests;	Out of scope of the present document.	n/a	6 Conformity Assessment materials
e)	failure and shutdown of CPDLC;	Out of scope of the present document.		6 Conformity Assessment materials
f)	the filing of flight plans regarding information pertaining to data link capability.	Out of scope of the present document.	Out of scope of the present document.	Out of scope of the present document.

## B.1.5 Article 5 Obligations of ATS providers for data link communications

Table B.4

Ref. §	Regulation EC 29/2009 [i.2] (as corrected) requires that:	CS Ref. Evidence on constituent level	CS Ref. Evidence on system level	CS Ref. Evidence on procedures
1.	ATS providers shall ensure that the ground systems referred to in Article 1(2) and their constituents support the air-ground applications defined in the ICAO standards specified in points 2 and 3 of Annex III.	Out of scope of the present document.	See clause B.2.3, Numbers 2 and 3	Out of scope of the present document.
2.	ATS providers shall ensure that the ground systems referred to in Article 1(2)(c) and their constituents apply end-to-end communications in compliance with the requirements of Part A of Annex IV for data exchanges of the air-ground applications defined in the ICAO standards specified in points 2 and 3 of Annex III.	Out of scope of the present document.	See clause B.2.4.1, Number 1	See clause B.2.4.1, numbers 1 and 2
3.	ATS providers that rely upon other organizations for the provision of communication services for data exchanges with aircraft which are necessary for air-ground applications defined in the ICAO standards specified in points 2 and 3 of Annex III shall ensure that those services are provided in accordance with the terms and conditions of a service level agreement, including in particular:	Out of scope of the present document.	Out of scope of the present document.	Out of scope of the present document.
(a)	the description of communication services in accordance with the requirements of the data link services defined in Annex II;	Out of scope of the present document.	Out of scope of the present document.	n/a
(b)	the description of the security policy put in place to secure data exchanges of the air-ground applications defined in the ICAO standards specified in points 2 and 3 of Annex III;	Out of scope of the present document.	Out of scope of the present document.	n/a
(c)	the relevant materials to be supplied for the monitoring of the quality of service and performances of communication services.	Out of scope of the present document.	Out of scope of the present document.	n/a

Ref. §	Regulation EC 29/2009 [i.2] (as corrected) requires that:	CS Ref. Evidence on constituent level	CS Ref. Evidence on system level	CS Ref. Evidence on procedures
4.	ATS providers shall make appropriate arrangements to ensure that data exchanges can be established with all aircraft flying in the airspace under their responsibility and having data link capability in accordance with the requirements of this Regulation, with due regard to possible coverage limitations inherent in the communication technology used.	Out of scope of the present document.	Out of scope of the present document.	n/a
5.	ATS providers shall implement in their flight data processing systems the log on forward and next authority notification processes between ATC units in accordance with Commission Regulation (EC) No 30/2009 [i.3] (1) as far as the requirements for automatic systems for the exchange of flight data supporting data link services are concerned.	Out of scope of the present document.	Out of scope of the present document.	n/a
6.	ATS providers shall monitor the quality of service of communication services and verify their conformance with the level of performance required for the operational environment under their responsibility.	Out of scope of the present document.	Out of scope of the present document.	n/a

## B.1.6 Article 6 Obligations of operators for data link communications

Table B.5

Ref. §	Regulation EC 29/2009 [i.2] (as corrected) requires that:	CS Ref. Evidence on constituent level	CS Ref. Evidence on system level	CS Ref. Evidence on procedures
1.	Operators shall ensure that airborne systems referred to in Article 1(2)(c) and their constituents installed on-board aircraft referred to in Article 3(2) and (3) support the air-ground applications defined in the ICAO standards specified in points 2 and 3 of Annex III.	Out of scope of the present document.	Out of scope of the present document.	Out of scope of the present document.
2.	Operators shall ensure that airborne systems referred to in Article 1(2)(c) and their constituents installed on-board aircraft referred to in Article 3(2) and (3) apply end-to-end communications in compliance with the requirements of Part A of Annex IV for data exchanges of the air-ground applications defined in the ICAO standards specified in points 2 and 3 of Annex III.	Out of scope of the present document.	Out of scope of the present document.	Out of scope of the present document.
3.	Operators shall ensure that airborne systems referred to in Article 1(2)(c) and their constituents installed on-board aircraft referred to in Article 3(2) and (3) apply air-ground communications in compliance with the requirements of Part B or Part C of Annex IV for data exchanges of the air-ground applications defined in the ICAO standards specified in points 2 and 3 of Annex III.	Out of scope of the present document.	Out of scope of the present document.	Out of scope of the present document.
4.	Operators referred to in paragraph 3 shall make appropriate arrangements to ensure that data exchanges can be established between their aircraft having data link capability and all ATS units which may control the flights they operate in the airspace referred to in Article 1(3), with due regard to possible coverage limitations inherent in the communication technology used.	Out of scope of the present document.	Out of scope of the present document.	Out of scope of the present document.

## B.1.7 Article 7 General obligations of Member States for data link communications

Table B.6

Ref. §	Regulation EC 29/2009 [i.2] (as corrected) requires that:	CS Ref. Evidence on constituent level	CS Ref. Evidence on system level	CS Ref. Evidence on procedures
1.	Member States which have designated ATS providers in the airspace referred to in Article 1(3) shall ensure that air-ground communications services applying the requirements of Part B of Annex IV are available to operators for aircraft flying within that airspace under their responsibility for data exchanges of the air-ground applications defined in the ICAO standards specified in points 2 and 3 of Annex III, with due regard to possible coverage limitations inherent in the communication technology used.	Out of scope of the present document.	Out of scope of the present document.	Out of scope of the present document.
2.	Member States shall ensure that air navigation service providers and other entities providing communication services implement an appropriate security policy for data exchanges of the data link services defined in Annex II, notably by applying common security rules to protect distributed physical resources supporting those data exchanges.	Out of scope of the present document.	Out of scope of the present document.	Out of scope of the present document.
3.	Member States shall ensure that harmonized procedures apply for the management of addressing information in order to unambiguously identify air and ground communications systems supporting data exchanges of the air-ground applications defined in the ICAO standards specified in points 2 and 3 of Annex III.	Out of scope of the present document.	Out of scope of the present document.	Out of scope of the present document.

## B.1.8 Article 8 Data link communication for transport type State aircraft

Table B.7

Ref. §	Regulation EC 29/2009 [i.2] (as corrected) requires that:	CS Ref. Evidence on constituent level	CS Ref. Evidence on system level	CS Ref. Evidence on procedures
1.	Member States shall ensure that airborne systems referred to in Article 1(2)(c) and their constituents installed on-board transport type State aircraft referred to in Article 3(5) support the air-ground applications defined in the ICAO standards specified in points 2 and 3 of Annex III.	Out of scope of the present document.	Out of scope of the present document.	Out of scope of the present document.
2.	Member States shall ensure that airborne systems referred to in Article 1(2)(c) and their constituents installed on-board transport type State aircraft referred to in Article 3(5) apply end-to-end communications in compliance with requirements of Part A of Annex IV for data exchanges of the air-ground applications defined in the ICAO standards specified in points 2 and 3 of Annex III.	Out of scope of the present document.	Out of scope of the present document.	Out of scope of the present document.
3.	Member States shall ensure that airborne systems referred to in Article 1(2)(c) and their constituents installed on-board transport type State aircraft referred to in Article 3(5) apply air-ground communications in compliance with requirements specified in Part B or Part C of Annex IV for data exchanges of the air-ground applications defined in the ICAO standards specified in points 2 and 3 of Annex III.	Out of scope of the present document.	Out of scope of the present document.	Out of scope of the present document.



## B.1.9 Article 9 Obligations of air navigation services providers and other entities for data link communications

**Table B.8**

Ref. §	Regulation EC 29/2009 [i.2] (as corrected) requires that:	CS Ref. Evidence on constituent level	CS Ref. Evidence on system level	CS Ref. Evidence on procedures
	Air navigation service providers and other entities providing communication services for data exchanges of the air-ground applications defined in the ICAO standards specified in points 2 and 3 of Annex III shall ensure that the ground systems referred to in Article 1(2)(c) apply air-ground communications in compliance with requirements of Part B or Part C of Annex IV.	Out of scope of the present document	See clause B.2.4.2	See clause B.2.4.2

## B.1.10 Article 10 Safety requirements

**Table B.9**

IR Ref.	Regulation EC 29/2009 [i.2] (as corrected) requires that:	CS Ref. Evidence on constituent level	CS Ref. Evidence on system level	CS Ref. Evidence on procedures
	Member States shall take the necessary measures to ensure that any changes to the existing systems referred to in Article 1(2) or the introduction of new systems are preceded by a safety assessment, including hazard identification, risk assessment and mitigation, conducted by the parties concerned.	Out of scope of the present document.	Out of scope of the present document.	Out of scope of the present document.

## B.1.11 Article 11 Conformity or suitability for use of constituents

Table B.10

Ref. §	Regulation EC 29/2009 [i.2] (as corrected) requires that:	CS Ref. Evidence on constituent level	CS Ref. Evidence on system level	CS Ref. Evidence on procedures
	<p>Before issuing an EC declaration of conformity or suitability for use referred to in Article 5 of Regulation (EC) No 552/2004 [i.6], manufacturers of constituents of the systems referred to in Article 1(2) of this Regulation, or their authorized representatives established in the Community, shall assess the conformity or suitability for use of those constituents in accordance with the requirements set out in Annex V. However, certification airworthiness processes complying with Regulation (EC) No 216/2008 [i.9], when applied to airborne constituents referred to in Article 1(2)(b) and (c) of this Regulation, shall be considered acceptable procedures for the conformity assessment of those constituents if they include the demonstration of compliance with the interoperability, performance and safety requirements of this Regulation.</p>	<p>Out of scope of the present document.</p>	<p>Out of scope of the present document.</p>	<p>Out of scope of the present document.</p>

## B.1.12 Article 12 Verification of systems

Table B.11

Ref. §	Regulation EC 29/2009 [i.2] (as corrected) requires that:	CS Ref. Evidence on constituent level	CS Ref. Evidence on system level	CS Ref. Evidence on procedures
1.	Air navigation service providers who demonstrate or have demonstrated that they fulfil the conditions set out in Annex VI shall conduct a verification of the systems referred to Article 1(2)(a) and (c) in compliance with the requirements set out in Part A of Annex VII.	Out of scope of the present document.	Out of scope of the present document.	Out of scope of the present document.
2.	Air navigation service providers which cannot demonstrate that they fulfil the conditions set out in Annex VI shall subcontract to a notified body a verification of the systems referred to in Article 1(2)(a) and (c). That verification shall be conducted in accordance with the requirements set out in Part B of Annex VII.	Out of scope of the present document.	Out of scope of the present document.	Out of scope of the present document.

## B.1.13 Article 13 Additional requirements

Table B.12

Ref. §	Regulation EC 29/2009 [i.2] (as corrected) requires that:	CS Ref. Evidence on constituent level	CS Ref. Evidence on system level	CS Ref. Evidence on procedures
1.	ATS providers shall ensure that air-ground data exchanges of the air-ground applications defined in the ICAO standards specified in points 2 and 3 of Annex III, are recorded in accordance with the ICAO standards specified in points 6, 7 and 8 of Annex III, insofar as they relate to the ground-based recording function of data link communications.	Out of scope of the present document.	4.1.3 Unconditional Constituent - Ground Data Recording equipment	Out of scope of the present document.
2.	The Eurocae document specified in point 9 of Annex III shall be considered sufficient means of compliance with regard to the requirements for recording of air-ground data exchanges referred to in paragraph 1 identified in the ICAO standards specified in points 6, 7 and 8 of Annex III.	Out of scope of the present document.	4.1.3 Unconditional Constituent - Ground Data Recording equipment	Out of scope of the present document.
3.	ATS providers shall:	n/a	n/a	Out of scope of the present document.
(a)	develop and maintain operations manuals containing the necessary instructions and information to enable all personnel concerned to apply this Regulation;	n/a	n/a	Out of scope of the present document.
(b)	ensure that the manuals referred to in point (a) are accessible and kept up to date and that their update and distribution are subject to appropriate quality and documentation configuration management;	n/a	n/a	Out of scope of the present document.
(c)	ensure that the working methods and operating procedures comply with this Regulation.	n/a	n/a	Out of scope of the present document.
4.	Member States shall take the necessary measures to ensure that the centralized flight planning processing and distribution service:	Out of scope of the present document.	Out of scope of the present document.	Out of scope of the present document.

Ref. §	Regulation EC 29/2009 [i.2] (as corrected) requires that:	CS Ref. Evidence on constituent level	CS Ref. Evidence on system level	CS Ref. Evidence on procedures
(a)	develops and maintains operations manuals containing the necessary instructions and information to enable all personnel concerned to apply this Regulation;	Out of scope of the present document.	Out of scope of the present document.	Out of scope of the present document.
(b)	ensures that the manuals referred to in point (a) are accessible and kept up to date and that their update and distribution are subject to appropriate quality and documentation configuration management;	Out of scope of the present document.	Out of scope of the present document.	Out of scope of the present document.
(c)	ensures that the working methods and operating procedures comply with this Regulation.	Out of scope of the present document.	Out of scope of the present document.	Out of scope of the present document.
5.	Air navigation service providers shall ensure that all personnel concerned are made duly aware of the relevant provisions of this Regulation and that they are adequately trained for their job functions.	Out of scope of the present document.	Out of scope of the present document.	Out of scope of the present document.
6.	Operators shall take the necessary measures to ensure that the personnel operating data link equipment are made duly aware of this Regulation and that they are adequately trained for their job functions, and that instructions about how to use data link equipment are available in the cockpit where feasible.	Out of scope of the present document.	Out of scope of the present document.	Out of scope of the present document.
7.	Member States shall take the necessary measures to ensure that the personnel involved in flight planning who operate the IFPS are made duly aware of the requirements laid down in this Regulation and that they are adequately trained for their job functions.	Out of scope of the present document.	Out of scope of the present document.	Out of scope of the present document.
8.	Member States shall ensure that relevant information on the use of data link services is published in the national aeronautical information publications.	Out of scope of the present document.	Out of scope of the present document.	Out of scope of the present document.

## B.1.14 Article 14 Exemptions

Table B.13

Ref. §	Regulation EC 29/2009 [i.2] (as corrected) requires that:	CS Ref. Evidence on constituent level	CS Ref. Evidence on system level	CS Ref. Evidence on procedures
1.	When particular circumstances, based on the criteria defined in paragraph 3, prevent aircraft of specific types from complying with the requirements of this Regulation, the Member States concerned shall communicate to the Commission by 31 December 2012 at the latest, detailed information justifying the need for granting exemptions to these aircraft types.	Out of scope of the present document.	Out of scope of the present document.	Out of scope of the present document.
2.	The Commission shall examine the requests for exemption referred to in paragraph 1 and, following consultation with the parties concerned, shall adopt a decision in accordance with the procedure referred to in Article 5(3) of Regulation (EC) No 549/2004 [i.5].	Out of scope of the present document.	Out of scope of the present document.	Out of scope of the present document.
3.	The criteria referred to in paragraph 1 shall be the following:	Out of scope of the present document.	Out of scope of the present document.	Out of scope of the present document.
(a)	aircraft types reaching the end of their production life and being produced in limited numbers; and	Out of scope of the present document.	Out of scope of the present document.	Out of scope of the present document.
(b)	aircraft types for which re-engineering costs required would be disproportionate due to old design.	Out of scope of the present document.	Out of scope of the present document.	Out of scope of the present document.

## B.1.15 Article 15 Entry into force and application

Table B.14

Ref. §	Regulation EC 29/2009 [i.2] (as corrected) requires that:	CS Ref. Evidence on constituent level	CS Ref. Evidence on system level	CS Ref. Evidence on procedures
	This Regulation shall enter into force on the 20th day following its publication in the <i>Official Journal of the European Union</i> .	Out of scope of the present document.	Out of scope of the present document.	Out of scope of the present document.
	This Regulation shall apply from 7 February 2013.	Out of scope of the present document.	Out of scope of the present document.	Out of scope of the present document.
	This Regulation shall be binding in its entirety and directly applicable in all Member States.	Out of scope of the present document.	Out of scope of the present document.	Out of scope of the present document.

## B.2 Annexes of the IR

### B.2.1 Annex I, Airspace referred to in Article 1(3)

Table B.15

Ref. §	Regulation EC 29/2009 [i.2] (as corrected) requires that:	CS Ref. Evidence on constituent level	CS Ref. Evidence on system level	CS Ref. Evidence on procedures
	Part A	Out of scope of the present document.	Out of scope of the present document.	Out of scope of the present document.
	The airspace referred to in the first paragraph of Article 1(3) shall include the airspace above FL 285 within the following Flight Information Regions (FIR) and Upper Flight Information Regions (UIR):	Out of scope of the present document.	Out of scope of the present document.	Out of scope of the present document.
	<ul style="list-style-type: none"> <li>- Amsterdam FIR,</li> <li>- Wien FIR,</li> <li>- Barcelona UIR,</li> <li>- Brindisi UIR,</li> <li>- Brussels UIR,</li> <li>- Canarias UIR,</li> <li>- France UIR,</li> <li>- Hannover UIR,</li> <li>- Lisboa UIR,</li> <li>- London UIR,</li> <li>- Madrid UIR,</li> <li>- Milano UIR,</li> <li>- Rhein UIR,</li> <li>- Roma UIR,</li> <li>- Scottish UIR,</li> <li>- Shannon UIR.</li> </ul>	Out of scope of the present document.	Out of scope of the present document.	Out of scope of the present document.



Ref. §	Regulation EC 29/2009 [i.2] (as corrected) requires that:	CS Ref. Evidence on constituent level	CS Ref. Evidence on system level	CS Ref. Evidence on procedures
	Part B	Out of scope of the present document.	Out of scope of the present document.	Out of scope of the present document.
	<p>The airspace referred to in the second paragraph of Article 1(3) shall include the airspace above FL 285 defined in Part A and in addition, the following Flight Information Regions and Upper Flight Information Regions:</p> <ul style="list-style-type: none"> <li>-Bratislava FIR,</li> <li>- Bucuresti FIR,</li> <li>- Budapest FIR,</li> <li>- Kobenhavn FIR,</li> <li>- Ljubljana FIR,</li> <li>- Nicosia FIR,</li> <li>- Praha FIR,</li> <li>- Sofia FIR,</li> <li>- Warszawa FIR,</li> <li>- Finland UIR south of 61°30',</li> <li>- Hellas UIR,</li> <li>- Malta UIR,</li> <li>- Riga UIR,</li> <li>- Sweden UIR south of 61°30',</li> <li>- Tallinn UIR,</li> <li>- Vilnius UIR.</li> </ul>	Out of scope of the present document.	Out of scope of the present document.	Out of scope of the present document.

## B.2.2 Annex II, Definition of data link services referred to in Articles 3, 4, 5 and 7 and Annex IV

Table B.16

Ref. §	Regulation EC 29/2009 [i.2] (as corrected) requires that:	CS Ref. Evidence on constituent level	CS Ref. Evidence on system level	CS Ref. Evidence on procedures
1.	<i>Definition of Data Link Communications Initiation Capability (DLIC)</i>	n/a	n/a	n/a
	The DLIC service shall enable the exchange of the necessary information for the establishment of data link communications between ground and aircraft data link systems.	n/a	4.2.3.1 DLIC	4.3.7 Eurocontrol DLS Specification, clause C.2.6.4
	The DLIC service shall be available to support:	n/a	n/a	n/a
-	the unambiguous association of flight data from the aircraft with flight plan data used by an ATS unit,		4.2.3.1 DLIC 4.2.3.1.1.5 EUROCONTROL DLS Specification, clause A.2.5.7 5.3.1 Test for CM Application	4.3.7 Eurocontrol DLS Specification, clause C.2.6.4
-	the exchange of the supported air-ground application type and version information,		4.2.3.1 DLIC 5.3.1 Test for CM Application	4.3.7 Eurocontrol DLS Specification, clause C.2.6.4
-	and the delivery of the addressing information of the entity hosting the application.		4.2.3.1 DLIC 5.3.1 Test for CM Application	4.3.7 Eurocontrol DLS Specification, clause C.2.6.4
	The exchanges between airborne and ground data link systems for the execution of DLIC service shall comply with:	n/a	n/a	n/a
-	operating methods, time sequence diagrams and messages for the DLIC initiation and DLIC contact functions specified in section 4.1 of the Eurocae document identified in point 11 of Annex III,		5.3 Test configuration with simulator	
-	safety requirements specified in clause 4.2.2 of the Eurocae document identified in point 11 of Annex III,		4.2.3.1.3 Specific Safety Requirements	n/a
-	performance requirements specified in clause 4.3.2 of the Eurocae document identified in point 11 of Annex III.		4.2.3.1.2 Specific Performance Requirements	n/a

Ref. §	Regulation EC 29/2009 [i.2] (as corrected) requires that:	CS Ref. Evidence on constituent level	CS Ref. Evidence on system level	CS Ref. Evidence on procedures
2.	<i>Definition of ATC Communications Management service (ACM)</i>	n/a	n/a	n/a
	The ACM service shall provide automated assistance to flight crews and air traffic controllers for conducting the transfer of ATC communications (voice and data) comprising:	n/a	n/a	n/a
-	the initial establishment of CPDLC with an ATS unit,	n/a	<b>4.2.3.2</b> ACM <b>5.3.2</b> Test for CPDLC Application <b>5.3.5</b> ACM Service	<b>4.3.3</b> Eurocontrol DLS Specification, clause C.2.2.4 <b>4.3.7</b> Eurocontrol DLS Specification, clause C.2.6.4
-	the transfer of CPDLC and voice for a flight from one ATS unit to the next ATS unit, or to instruct a change of voice channel within an ATS unit or sector,		<b>4.2.3.2</b> ACM <b>5.3.2</b> Test for CPDLC Application <b>5.3.5</b> ACM Service	<b>4.3.3</b> Eurocontrol DLS Specification, clause C.2.2.4 <b>4.3.5</b> Eurocontrol DLS Specification, clause C.2.3.3 <b>6</b> Conformity Assessment materials
-	the normal termination of CPDLC with an ATS unit.	n/a	<b>4.2.3.2</b> ACM <b>5.3.2</b> Test for CPDLC Application <b>5.3.5</b> ACM Service	n/a
	The exchanges between airborne and ground data link systems for the execution of ACM service shall comply with:	n/a	n/a	n/a
-	operating methods and time sequence diagrams specified in clauses 5.1.1.1.1 to 5.1.1.1.7 and 5.1.1.2 of the Eurocae document identified in point 11 of Annex III,	n/a	<b>5.3</b> Test configuration with simulator	n/a
-	safety requirements specified in clause 5.1.2.3 of the Eurocae document identified in point 11 of Annex III, excluding requirements relating to downstream clearance,	n/a	<b>4.2.3.2.5</b> Specific Safety Requirements	n/a
-	performance requirements for the en route phase specified in clause 5.1.3.2 of the Eurocae document identified in point 11 of Annex III.	n/a	<b>4.2.3.2.4</b> Specific Performance Requirements	n/a
3.	<i>Definition of ATC Clearances and Information service (ACL)</i>	n/a	n/a	n/a
	The ACL service shall provide flight crews and controllers with the ability to conduct operational exchanges comprising:	n/a	n/a	n/a

Ref. §	Regulation EC 29/2009 [i.2] (as corrected) requires that:	CS Ref. Evidence on constituent level	CS Ref. Evidence on system level	CS Ref. Evidence on procedures
-	requests and reports from flight crews to air traffic controllers,	n/a	4.2.3.3 ACL 5.4 Test with real aircraft 5.3.2 Test for CPDLC Application 5.3.3 ACL Service	4.3.3 Eurocontrol DLS Specification, clause C.2.2.4 4.3.4 Eurocontrol DLS Specification, clause C.2.2.6 6 Conformity Assessment Material
-	clearances, instructions and notifications issued by air traffic controllers to flight crews.	n/a	4.2.3.3 ACL 5.4 Test with real aircraft 5.3.2 Test for CPDLC Application 5.3.3 ACL Service	4.3.3 Eurocontrol DLS Specification, clause C.2.2.4 4.3.4 Eurocontrol DLS Specification, clause C.2.2.6 6 Conformity Assessment Material
	The exchanges between airborne and ground data link systems for the execution of ACL service shall comply with:	n/a	n/a	n/a
-	operating methods and time sequence diagrams specified in clauses 5.2.1.1.1 to 5.2.1.1.4 and 5.2.1.2 of the Eurocae document identified in point 11 of Annex III,	n/a	5.3.3 ACL Service	n/a
-	a common subset of the message elements specified in clause 5.2.1.1.5 of the Eurocae document identified in point 11 of Annex III as appropriate to the en route operational environment,	n/a	4.2.3.3.2 ACL Uplink Message Elements 4.2.3.3.3 ACL Downlink Message Elements	n/a
-	safety requirements specified in clause 5.2.2.3 of the Eurocae document identified in point 11 of Annex III,	n/a	4.2.3.3.7 Specific Safety Requirements	n/a
-	performance requirements for the en route phase specified in clause 5.2.3.2 of the Eurocae document identified in point 11 of Annex III.	n/a	4.2.3.3.6 Specific Performance Requirements	n/a
4.	<i>Definition of ATC Microphone Check service (AMC)</i>	n/a	n/a	n/a
	The AMC service shall provide air traffic controllers with the capability to send an instruction to several data link equipped aircraft, at the same time, in order to instruct flight crews to verify that their voice communication equipment is not blocking a given voice channel.	n/a	4.2.3.4 AMC 5.3.4 AMC Service	4.3.3 Eurocontrol DLS Specification, clause C.2.2.4 6 Conformity Assessment Material
	This instruction shall only be issued to those aircraft tuned to the frequency that is blocked.	n/a	4.2.3.4 AMC	6 Conformity Assessment Material

Ref. §	Regulation EC 29/2009 [i.2] (as corrected) requires that:	CS Ref. Evidence on constituent level	CS Ref. Evidence on system level	CS Ref. Evidence on procedures
	The exchanges between airborne and ground data link systems for the execution of AMC service shall comply with:	n/a	n/a	n/a
-	operating methods and time sequence diagrams specified in clauses 5.3.1.1.1, 5.3.1.1.2 and 5.3.1.2 of the Eurocae document identified in point 11 of Annex III,	n/a	5.3.4 AMC Service	n/a
-	safety requirements specified in clause 5.3.2.3 of the Eurocae document identified in point 11 of Annex III,	n/a	4.2.3.4.5 Specific Safety Requirements	n/a
-	performance requirements specified in clause 5.3.3.2 of the Eurocae document identified in point 11 of Annex III.	n/a	4.2.3.4.4 Specific Performance Requirements	n/a

### B.2.3 Annex III, ICAO provisions referred to in Articles 3, 5, 6, 7, 8, 9 and 13 and Annex IV / Eurocae documents referred to in Articles 3 and 13 and Annex II

Table B.17

Ref. §	Regulation EC 29/2009 [i.2] (as corrected) requires that:	CS Ref. Evidence on constituent level	CS Ref. Evidence on system level	CS Ref. Evidence on procedures
1.	Subpart B, OPS 1 030, of Annex III to Regulation (EEC) No 3922/91.	n/a	n/a	n/a
2.	Chapter 3 - Aeronautical Telecommunication Network, section 3.5.1.1 'Context Management' (CM) application items (a) and (b) of ICAO Annex 10 - Aeronautical Telecommunications - Volume III, Part I (Digital Data Communication Systems) (First edition July 1995 incorporating Amendment 81 (23.11.2006)).	n/a	4.2.3.1 DLIC 5.4 Test with real aircraft 5.3.1 Test for CM Application	n/a
3.	Chapter 3 - Aeronautical Telecommunication Network, section 3.5.2.2 'Controller-Pilot Data Link Communications' (CPDLC) application items (a) and (b) of ICAO Annex 10 - Aeronautical Telecommunications - Volume III, Part I (Digital Data Communication Systems) (First edition July 1995 incorporating Amendment 81 (23.11.2006)).	n/a	4.2.3.2 ACM 4.2.3.3 ACL 4.2.3.4 AMC 5.4 Test with real aircraft 5.3.2 Test for CPDLC Application 5.3.3 ACL Service 5.3.4 AMC Service 5.3.5 ACM Service	n/a

Ref. §	Regulation EC 29/2009 [i.2] (as corrected) requires that:	CS Ref. Evidence on constituent level	CS Ref. Evidence on system level	CS Ref. Evidence on procedures
4.	Chapter 3 - Aeronautical Telecommunication Network, sections 3.3, 3.4 and 3.6 of ICAO Annex 10 - Aeronautical Telecommunications - Volume III, Part I (Digital Data Communication Systems) (First edition July 1995 incorporating Amendment 81 (23.11.2006)).	n/a	<p>4.1.1.2 Eurocontrol DLS Specification, clause B.2.1.2</p> <p>4.1.2.12 Eurocontrol DLS Specification, clause B.2.4.8</p> <p>4.1.2.13 Eurocontrol DLS Specification, clause B.2.1.2</p> <p>4.1.2.20 Eurocontrol DLS Specification, clause B.2.4.1</p> <p>4.1.5.1 Eurocontrol DLS Specification, clause B.2.1.2</p> <p>4.1.1.4 Eurocontrol DLS Specification, clause B.2.5.1</p> <p>4.1.1.5 Eurocontrol DLS Specification, clause B.2.5.5</p> <p>4.1.2.25 Eurocontrol DLS Specification, clause B.2.5.1</p> <p>4.1.2.27 Eurocontrol DLS Specification, clause B.2.5.5</p> <p>4.1.5.3 Eurocontrol DLS Specification, clause B.2.5.1</p> <p>4.1.5.5 Eurocontrol DLS Specification, clause B.2.5.5</p>	n/a
5.	Chapter 6 - VHF air-ground digital link (VDL) of ICAO Annex 10 - Aeronautical Telecommunications - Volume III, Part I (Digital Data Communication Systems) (First edition July 1995 incorporating Amendment 81 (23.11.2006)).	n/a	4.1.6 Conditional Constituent - VDL Mode 2 ground communications equipment	n/a
6.	Chapter 3 - General procedures for the international aeronautical telecommunication service, section 3.5.1.5 of ICAO Annex 10 - Aeronautical Telecommunications - Volume II, (Communication Procedures) (Sixth edition October 2001 incorporating Amendment 81 (23.11.2006)).	n/a	4.1.3 Unconditional Constituent - Ground Data Recording equipment	n/a
7.	Chapter 2 - General - sections 2.25.3 of ICAO Annex 11 - Air Traffic Services (13th edition July 2001 incorporating Amendment 45 (16.7.2007)).	n/a	n/a	n/a

Ref. §	Regulation EC 29/2009 [i.2] (as corrected) requires that:	CS Ref. Evidence on constituent level	CS Ref. Evidence on system level	CS Ref. Evidence on procedures
8.	Chapter 6 - Air traffic services requirements for communications - sections 6.1.1.2, of ICAO Annex 11 - Air Traffic Services (13th edition - July 2001 incorporating Amendment 45 (16.7.2007)).	n/a	n/a	n/a
9.	Eurocae ED-111, Functional specifications for CNS/ATM ground recording, July 2002, including Amendment 1 (30.7.2003).		4.1.3 Unconditional Constituent - Ground Data Recording equipment	n/a
10.	Eurocae ED-100 (September 2000) and ED-100A (April 2005), Interoperability requirements for ATS applications using ARINC 622 Data Communications.	n/a - airborne related	n/a - airborne related	n/a - airborne related
11.	Eurocae ED-120 Safety and Performance Requirements Standard for Air Traffic Data Link Services in Continental Airspace, published in May 2004, including Change 1, published in April 2007, and Change 2, published in October 2007.	n/a	4.2.1 Performance Requirements 4.2.2 Safety Requirements 4.2.3.1.2 Specific Performance Requirements 4.2.3.1.3 Specific Safety Requirements 4.2.3.2.4 Specific Performance Requirements 4.2.3.2.5 Specific Safety Requirements 4.2.3.3.6 Specific Performance Requirements 4.2.3.3.7 Specific Safety Requirements 4.2.3.4.4 Specific Performance Requirements 4.2.3.4.5 Specific Safety Requirements	n/a



## B.2.4 Annex IV, Requirements referred to in Articles 5, 6, 7, 8 and 9

### B.2.4.1 Part A: Requirements for end-to-end communications

Table B.18

Ref. §	Regulation EC 29/2009 [i.2] (as corrected) requires that:	CS Ref. Evidence on constituent level	CS Ref. Evidence on system level	CS Ref. Evidence on procedures
1.	End-to-end data communications shall ensure seamless provision and use of communication services in the airspace referred to in Article 1(3).	n/a	4.2.3.1.1 Specific Interoperability Requirements 4.2.3.2.1 Specific Interoperability Requirements 4.2.3.3.1 Specific Interoperability Requirements 4.2.3.4.1 Specific Interoperability Requirements 5.4 Test with real aircraft	n/a
2.	End-to-end data communications shall support the exchange of messages in support of the data link services defined in Annex II, in accordance with a common standardized messages set.	n/a	4.2.3.1 DLIC 4.2.3.2 ACM 4.2.3.3 ACL 4.2.3.4 AMC 5.4 Test with real aircraft 5.3 Test configuration with simulator	n/a
3.	End-to-end data communications shall support a common standardized end-to-end protection mechanism to ensure the integrity of messages received consistent with safety requirements of the data link services defined in Annex II.	n/a	4.1.2.14 Eurocontrol DLS Specification, clause B.2.2.1 4.2.3.2.5 Specific Safety Requirements 4.2.3.3.7 Specific Safety Requirements 4.2.3.4.5 Specific Safety Requirements 5.4 Test with real aircraft	n/a

## B.2.4.2 Part B: Requirements for air-ground communications based on ATN and VDL Mode 2

Table B.19

Ref. §	Regulation EC 29/2009 [i.2] (as corrected) requires that:	CS Ref. Evidence on constituent level	CS Ref. Evidence on system level	CS Ref. Evidence on procedures
1.	Air-ground communications shall be designed to support end-to-end communications and to ensure seamless provision and use of communications services to air-ground applications defined in the ICAO standards specified in points 2 and 3 of Annex III in the airspace referred to in Article 1(3).	n/a	4.2.3.1 DLIC 4.2.3.2 ACM 4.2.3.3 ACL 4.2.3.4 AMC 5.4 Test with real aircraft	n/a
2.	Air-ground communications shall comply with safety and performance requirements of the data link services defined in Annex II.	n/a	4.2.1 Performance Requirements 4.2.3.1.2 Specific Performance Requirements 4.2.3.2.4 4.2.3.3.6 Specific performance Requirements 4.2.3.4.4 Specific Performance Requirements 4.2.2 Safety Requirements 4.2.3.1.3 Specific Safety Requirements 4.2.3.2.5 Specific Safety Requirements 4.2.3.3.7 Specific Safety Requirements 4.2.3.4.5 Specific Safety Requirements	n/a
3.	Air-ground communications shall be based on a common addressing scheme.	n/a	n/a	4.3.6 Eurocontrol DLS Specification, clause C.2.6.3 4.3.7 Eurocontrol DLS Specification, clause C.2.6.4

Ref. §	Regulation EC 29/2009 [i.2] (as corrected) requires that:	CS Ref. Evidence on constituent level	CS Ref. Evidence on system level	CS Ref. Evidence on procedures
4.	The transmission and reception of data units between ground and aircraft systems hosting the air-ground applications defined in the ICAO standards specified in points 2 and 3 of Annex III shall be based on communication protocols which comply with the ICAO standards defining the Aeronautical Telecommunication Network referred to in point 4 of Annex III.	n/a	<p>4.1.1.1 Eurocontrol DLS Specification, clause B.2.1.1</p> <p>4.1.1.3 Eurocontrol DLS Specification, clause B.2.1.3</p> <p>4.1.1.4 Eurocontrol DLS Specification, clause B.2.5.1</p> <p>4.1.1.5 Eurocontrol DLS Specification, clause B.2.5.5</p> <p>4.1.2.11 Eurocontrol DLS Specification, clause B.2.1.3</p> <p>4.1.2.12 Eurocontrol DLS Specification, clause B.2.4.8</p> <p>4.1.2.15 Eurocontrol DLS Specification, clause B.2.2.2</p> <p>4.1.2.20 Eurocontrol DLS Specification, clause B.2.4.1</p> <p>4.1.2.21 Eurocontrol DLS Specification, clause B.2.4.2</p> <p>4.1.2.23 Eurocontrol DLS Specification, clause B.2.4.5</p>	n/a
5.	The ground and aircraft communication system characteristics and the transmission and reception of bit frames between ground and aircraft communication systems shall comply with the ICAO standards defining the very high frequency digital link, VDL Mode 2, referred to in point 5 of Annex III.	n/a	4.1.3 Unconditional Constituent - Ground Data Recording equipment	n/a

### B.2.4.3 Part C: Requirements for air-ground communications based on other communication protocols

**Table B.20**

Ref. §	Regulation EC 29/2009 [i.2] (as corrected) requires that:	CS Ref. Evidence on constituent level	CS Ref. Evidence on system level	CS Ref. Evidence on procedures
1.	Air-ground communications shall be designed to support end-to-end communications and to ensure seamless provision and use of communications services to air-ground applications defined in the ICAO standards specified in points 2 and 3 of Annex III in the airspace referred to in Article 1(3).	Out of scope of the present document.	Out of scope of the present document.	Out of scope of the present document.
2.	Air-ground communications shall comply with safety and performance requirements of the data link services defined in Annex II.	Out of scope of the present document.	Out of scope of the present document.	Out of scope of the present document.
3.	Air-ground communications shall be based on a common addressing scheme.	Out of scope of the present document.	Out of scope of the present document.	Out of scope of the present document.
4.	The transmission and reception of bit frames between ground and aircraft communication systems shall be based on communication protocols fulfilling the conditions set out in Part D.	Out of scope of the present document.	Out of scope of the present document.	Out of scope of the present document.

## B.2.4.4 Part D: Conditions referred to in Part C

Table B.21

Ref. §	Regulation EC 29/2009 [i.2] (as corrected) requires that:	CS Ref. Evidence on constituent level	CS Ref. Evidence on system level	CS Ref. Evidence on procedures
1.	Communication protocols must support end-to-end communications.	Out of scope of the present document.	Out of scope of the present document.	Out of scope of the present document.
2.	Communication protocols must be subject to a safety case to demonstrate compliance with safety and performance requirements of the data link services defined in Annex II.	Out of scope of the present document.	Out of scope of the present document.	Out of scope of the present document.
3.	Communication protocols must support bidirectional point-to-point communications using those parts of the radio frequency spectrum identified by ICAO as suitable for air-ground data communications in support of air traffic services.	Out of scope of the present document.	Out of scope of the present document.	Out of scope of the present document.
4.	Communication protocols must include a mechanism to manage mobile connectivity between ground and airborne stations in a transparent way.	Out of scope of the present document.	Out of scope of the present document.	Out of scope of the present document.
5.	Communication protocols must be specified and validated with respect to airworthiness regulations and operational approval regulations applicable to aircraft communication equipment.	Out of scope of the present document.	Out of scope of the present document.	Out of scope of the present document.
6.	Communication systems supporting these protocols must not create harmful effects on airborne and ground installations supporting VDL Mode 2.	Out of scope of the present document.	Out of scope of the present document.	Out of scope of the present document.

## B.2.5 Annex V, Requirements for the assessment referred to in Article 11 of the conformity or suitability for use of constituents

Table B.22

Ref. §	Regulation EC 29/2009 [i.2] (as corrected) requires that:	CS Ref. Evidence on constituent level	CS Ref. Evidence on system level	CS Ref. Evidence on procedures
1.	The verification activities shall demonstrate the conformity or suitability for use of constituents implementing the data link services, end-to-end communications and air-ground communications with the applicable requirements of this Regulation whilst those constituents are in operation in the test environment.	Out of scope of the present document.	Out of scope of the present document.	Out of scope of the present document.
2.	The manufacturer shall manage the conformity assessment activities and shall in particular:	Out of scope of the present document.	Out of scope of the present document.	Out of scope of the present document.
-	determine the appropriate test environment,	Out of scope of the present document.	Out of scope of the present document.	Out of scope of the present document.
-	verify that the test plan describes the constituents in the test environment,	Out of scope of the present document.	Out of scope of the present document.	Out of scope of the present document.
-	verify that the test plan provides full coverage of applicable requirements,	Out of scope of the present document.	Out of scope of the present document.	Out of scope of the present document.
-	ensure the consistency and quality of the technical documentation and the test plan,	Out of scope of the present document.	Out of scope of the present document.	Out of scope of the present document.
-	plan the test organization, staff, installation and configuration of test platform,	Out of scope of the present document.	Out of scope of the present document.	Out of scope of the present document.
-	perform the inspections and tests as specified in the test plan,	Out of scope of the present document.	Out of scope of the present document.	Out of scope of the present document.
-	write the report presenting the results of inspections and tests.	Out of scope of the present document.	Out of scope of the present document.	Out of scope of the present document.
3.	The manufacturer shall ensure that the constituents implementing data link services, end-to-end communications and air-ground communications, integrated in the test environment meet the applicable requirements of this Regulation.	Out of scope of the present document.	Out of scope of the present document.	Out of scope of the present document.

Ref. §	Regulation EC 29/2009 [i.2] (as corrected) requires that:	CS Ref. Evidence on constituent level	CS Ref. Evidence on system level	CS Ref. Evidence on procedures
4.	Upon satisfying completion of verification of conformity or suitability for use, the manufacturer shall under its responsibility draw up the EC declaration of conformity or suitability for use, specifying the applicable requirements of this Regulation met by the constituent and its associated conditions of use in accordance with point 3 of Annex III to Regulation (EC) No 552/2004 [i.6].	Out of scope of the present document.	Out of scope of the present document.	Out of scope of the present document.

## B.2.6 Annex VI, Conditions referred to in Article 12

Table B.23

Ref. §	Regulation EC 29/2009 [i.2] (as corrected) requires that:	CS Ref. Evidence on constituent level	CS Ref. Evidence on system level	CS Ref. Evidence on procedures
1.	The air navigation service provider must have in place reporting methods within the organization which ensure and demonstrate impartiality and independence of judgement in relation to the verification activities.	Out of scope of the present document.	Out of scope of the present document.	Out of scope of the present document.
2.	The air navigation service provider must ensure that the personnel involved in verification processes, carry out the checks with the greatest possible professional integrity and the greatest possible technical competence and are free of any pressure and incentive, in particular of a financial type, which could affect their judgement or the results of their checks, in particular from persons or groups of persons affected by the results of the checks.	Out of scope of the present document.	Out of scope of the present document.	Out of scope of the present document.
3.	The air navigation service provider must ensure that the personnel involved in verification processes, have access to the equipment that enables them to properly perform the required checks.	Out of scope of the present document.	Out of scope of the present document.	Out of scope of the present document.
4.	The air navigation service provider must ensure that the personnel involved in verification processes, have sound technical and vocational training, satisfactory knowledge of the requirements of the verifications they have to carry out, adequate experience of such operations, and the ability required to draw up the declarations, records and reports to demonstrate that the verifications have been carried out.	Out of scope of the present document.	Out of scope of the present document.	Out of scope of the present document.



Ref. §	Regulation EC 29/2009 [i.2] (as corrected) requires that:	CS Ref. Evidence on constituent level	CS Ref. Evidence on system level	CS Ref. Evidence on procedures
5.	The air navigation service provider must ensure that the personnel involved in verification processes, are able to perform their checks with impartiality. Their remuneration shall not depend on the number of checks carried out, or on the results of such checks.	Out of scope of the present document.	Out of scope of the present document.	Out of scope of the present document.

## B.2.7 Annex VII

### B.2.7.1 Part A: Requirements for the verification of systems referred to in Article 12(1)

Table B.24

Ref. §	Regulation EC 29/2009 [i.2] (as corrected) requires that:	CS Ref. Evidence on constituent level	CS Ref. Evidence on system level	CS Ref. Evidence on procedures
1.	The verification of systems identified in Article 1(2) shall demonstrate the conformity of these systems with the applicable requirements of this Regulation in an assessment environment that reflects the operational context of these systems.	n/a	Not covered by the present document.	n/a
2.	The verification of systems identified in Article 1(2) shall be conducted in accordance with appropriate and recognized testing practices.	n/a	Not covered by the present document.	n/a
3.	Test tools used for the verification of systems identified in Article 1(2) shall have appropriate functionalities.	n/a	Not covered by the present document.	n/a
4.	The verification of systems identified in Article 1(2) shall produce the elements of the technical file required by point 3 of Annex IV to Regulation (EC) No 552/2004 [i.6], including the following elements:	n/a	Not covered by the present document.	n/a
-	description of the implementation,	n/a	Not covered by the present document.	n/a
-	the report of inspections and tests achieved before putting the system into service.	n/a	Not covered by the present document.	n/a
5.	The air navigation service provider shall manage the verification activities and shall in particular:	n/a	Not covered by the present document.	n/a
-	determine the appropriate operational and technical assessment environment reflecting the operational environment,	n/a	Not covered by the present document.	n/a
-	verify that the test plan describes the integration of systems identified in Article 1(2) in an operational and technical assessment environment,	n/a	Not covered by the present document.	n/a

Ref. §	Regulation EC 29/2009 [i.2] (as corrected) requires that:	CS Ref. Evidence on constituent level	CS Ref. Evidence on system level	CS Ref. Evidence on procedures
-	verify that the test plan provides full coverage of the interoperability and performance requirements of this Regulation,	n/a	Not covered by the present document.	n/a
-	ensure the consistency and quality of the technical documentation and the test plan,	n/a	Not covered by the present document.	n/a
-	plan the test organization, staff, installation and configuration of the test platform,	n/a	Not covered by the present document.	n/a
-	perform the inspections and tests as specified in the test plan,	n/a	Not covered by the present document.	n/a
-	write the report presenting the results of inspections and tests.	n/a	Not covered by the present document.	n/a
6.	The air navigation service provider shall ensure that the systems identified in Article 1(2) operated in an operational assessment environment meet the applicable requirements of this Regulation.	n/a	Not covered by the present document.	n/a
7.	Upon satisfying completion of verification of compliance, air navigation service providers shall draw up the EC declaration of verification of system and submit it to the national supervisory authority together with the technical file as required by Article 6 of Regulation (EC) No 552/2004 [i.6].	n/a	Not covered by the present document.	n/a

## B.2.7.2 Part B: Requirements for the verification of systems referred to in Article 12(2)

Table B.25

Ref. §.	Regulation EC 29/2009 [i.2] (as corrected) requires that:	CS Ref. Evidence on constituent level	CS Ref. Evidence on system level	CS Ref. Evidence on procedures
1.	The verification of systems identified in Article 1(2) shall demonstrate the conformity of these systems with the applicable requirements of this Regulation in an assessment environment that reflects the operational context of these systems.	n/a	Not covered by the present document.	n/a
2.	The verification of systems identified in Article 1(2) shall be conducted in accordance with appropriate and recognized testing practices.	n/a	Not covered by the present document.	n/a
3.	Test tools used for the verification of systems identified in Article 1(2) shall have appropriate functionalities.	n/a	Not covered by the present document.	n/a
4.	The verification of systems identified in Article 1(2) shall produce the elements of the technical file required by point 3 of Annex IV to Regulation (EC) No 552/2004 [i.6], including the following elements:	n/a	Not covered by the present document.	n/a
-	description of the implementation,	n/a	Not covered by the present document.	n/a
-	the report of inspections and tests achieved before putting the system into service.	n/a	Not covered by the present document.	n/a
5.	The air navigation service provider shall determine the appropriate operational and technical assessment environment reflecting the operational environment and shall have verification activities performed by a notified body.	n/a	Not covered by the present document.	n/a
6.	The notified body shall manage the verification activities and shall in particular:	n/a	Not covered by the present document.	n/a
-	verify that the test plan describes the integration of systems identified in Article 1(2) in an operational and technical assessment environment,	5 System Testing	Not covered by the present document.	n/a
-	verify that the test plan provides full coverage of the requirements of this Regulation,	n/a	Not covered by the present document.	n/a

Ref. §.	Regulation EC 29/2009 [i.2] (as corrected) requires that:	CS Ref. Evidence on constituent level	CS Ref. Evidence on system level	CS Ref. Evidence on procedures
-	ensure the consistency and quality of the technical documentation and the test plan,	n/a	Not covered by the present document.	n/a
-	plan the test organization, staff, installation and configuration of the test platform,	n/a	Not covered by the present document.	n/a
-	perform the inspections and tests as specified in the test plan,	n/a	Not covered by the present document.	n/a
-	write the report presenting the results of inspections and tests.	n/a	Not covered by the present document.	n/a
7.	The notified body shall ensure that the systems identified in Article 1(2) operated in an operational assessment environment meet the applicable requirements of this Regulation.	n/a	Not covered by the present document.	n/a
8.	Upon satisfying completion of verification tasks, the notified body shall draw up a certificate of conformity in relation to the tasks it carried out.	n/a	Not covered by the present document.	n/a
9.	Then, the air navigation service provider shall draw up the EC declaration of verification of system and submit it to the national supervisory authority together with the technical file as required by Article 6 of Regulation (EC) No 552/2004.	n/a	Not covered by the present document.	n/a

## Annex C (normative): Traceability of tests on Data Link Services

The purpose of the present annex is to provide a comprehensive traceability of tests to be conducted against the requirements on Data link-Service of the present document.

NOTE: Each numbered requirement of the present document is reproduced in the first four columns of the table below followed by a cross-reference to the corresponding test in the present document.  
In the central two columns, "U" stands for "unconditional". It means that the requirement has to be supported. On the contrary, "C" stands for "conditional". It means that the requirement has to be supported only under certain conditions.  
In the last two columns, "E" stands for "Essential Test". It means that the test is specified in the present document and has to be conducted. On the contrary, "O" stands for "Other Test". It means that the test is not specified in the present document and has to be designed and conducted by the provider of the corresponding constituent.

**Table C.1**

Requirement of the present document		Requirement conditionality		Test specification	
Clause	Description	U/C	Condition	E/O	Reference
4	Present document shall have precedence over ED-110B [6].	U	NA	NA	NA
4.1.1.1	CSPs and ATSPs shall operate Ground-Ground ATN routers.	U	NA	O	
4.1.1.2	Ground-Ground ATN routers shall comply with ED-110B [6] § 2 and 3.	U	NA	O	Declaration of Conformity or Declaration of Suitability for Use.
4.1.1.3	Ground-Ground ATN routers Implementations shall incorporate defect resolutions to Doc 9705 [4].	C	It is up to the implementation to use it or not.	O	Declaration of Conformity or Declaration of Suitability for Use.
4.1.1.4	ICS implementations in Ground-Ground ATN routers shall conform to ED-110B [6].	U	NA	O	Declaration of Conformity or Declaration of Suitability for Use.
4.1.1.5	ICS implementations in Ground-Ground ATN routers shall incorporate defect resolutions to Doc 9705 [4].	See table 2		O	Declaration of Conformity or Declaration of Suitability for Use.
4.1.1.6	Ground-Ground ATN routers shall implement specified IDRP parameter setting.	C	It is up to the implementation to use it or not.	O	Declaration of Conformity or Declaration of Suitability for Use.
4.1.2.1	ATM Data Processing System shall send error response to aircraft for DM not supported.	U	NA	E	Clause 5: CPDLC_008.
4.1.2.2	ATM Data Processing System shall be able to send all UM to support ACM, ACL and AMC.	U	NA	E	Clause 5: ACL_001, ACL_002, ACL_003, ACL_004, ACL_005, ACL_006, ACL_007, ACL_008, AMC_001, AMC_002, ACM_001, ACM_002, ACM_003.
4.1.2.3	Latitude and longitude shall be coded with	U	NA	O	

Requirement of the present document		Requirement conditionality		Test specification	
Clause	Description	U/C	Condition	E/O	Reference
	(°, mn, s) format in ATM Data Processing System.				
4.1.2.4	Lack messages (DM100 & UM227) shall be used in ACL and ACM.	U		E	Clause 5: EE_001, ACL_001, ACL_002, ACL_003, ACL_004, ACL_006, ACL_007, ACL_008, ACM_001, ACM_002, ACM_003, ACM_004, ACM_005, ACM_006, ACM_007.
4.1.2.5	ATM Data Processing System shall comply with clause 4.2.3.2.2 on uplink ACM.	U		E	Clause 5: EE_001, ACM_001, ACM_002, ACM_003, ACM_004, ACM_005, ACM_006, ACM_007.
4.1.2.6	ATM Data Processing System shall comply with clause 4.2.3.2.3 on downlink ACM.	U		E	Clause 5: EE_001, ACM_001, ACM_002, ACM_003, ACM_004, ACM_005, ACM_006, ACM_007.
4.1.2.7	Implementations of ACL shall comply with ED-110B [6].	U		E	Clause 5: EE_001, ACL_001, ACL_002, ACL_003, ACL_004, ACL_005, ACL_006, ACL_007, ACL_008.
4.1.2.8	ATM Data Processing System shall comply with clause 4.2.3.3.2 on uplink ACL.	U		E	Clause 5: EE_001, ACL_001, ACL_002, ACL_003, ACL_004, ACL_005, ACL_006, ACL_007, ACL_008.
4.1.2.9	ATM Data Processing System shall comply with clause 4.2.3.3.3 on downlink ACL.	U		E	Clause 5: EE_001, ACL_001, ACL_002, ACL_003, ACL_004, ACL_005, ACL_006, ACL_007, ACL_008.
4.1.2.10	ATM Data Processing System shall comply with clause 4.2.3.4.2 on uplink AMC.	U		E	Clause 5: AMC_001 or AMC_002, depending on the implementation choice.
4.1.2.11	ATM Data Processing System shall incorporate defect resolutions to Doc 9705 [4].	C	It is up to the implementation to use it or not.	O	
4.1.2.12	ULCS implementations in ATM Data Processing System shall incorporate defect resolutions to Doc 9705 [4].	C	It is up to the implementation to use it or not.	O	
4.1.2.13	ATN ES shall comply with ED-110B [6].	U		E	Clause 5: ACL_001, ACL_002, ACL_003, ACL_004, ACL_005, ACL_006, ACL_007, ACL_008, AMC_001, AMC_002, ACM_001, ACM_002, ACM_003, ACM_004, ACM_005, ACM_006, ACM_007, EE_001.
4.1.2.14	Ground AE shall comply with ED-110B [6].	U		E	Clause5: CM_001, CM_002, CM_003, CM_004, CPDLC_001, CPDLC_002, CPDLC_003, CPDLC_004, CPDLC_005, CPDLC_006, CPDLC_007, CPDLC_008, CPDLC_009, CPDLC_010, CPDLC_011, CPDLC_012, CPDLC_013, CPDLC_014, CPDLC_015, CPDLC_016, CPDLC_017, CPDLC_018, EE_001.
4.1.2.15	ATM Data Processing System shall be able	U		E	Clause 5: ACL_001, ACL_002, ACL_003,

Requirement of the present document		Requirement conditionality		Test specification	
Clause	Description	U/C	Condition	E/O	Reference
	to receive all DM of Doc 9705 [4] and handle unsupported DM as in ED-110B [6].				ACL_004, ACL_005, ACL_006, ACL_007, ACL_008, , ACM_001, ACM_002, ACM_003, ACM_004, ACM_005, ACM_006, ACM_007, CPDLC_001, CPDLC_002, CPDLC_003, CPDLC_004, CPDLC_005, CPDLC_006, CPDLC_007, CPDLC_008, CPDLC_009, CPDLC_010, CPDLC_011, CPDLC_012, CPDLC_013, CPDLC_014, CPDLC_015, CPDLC_016, CPDLC_017, CPDLC_018.
4.1.2.16	ATM Data Processing System shall use integrity check mechanism as defined in ED-110B [6].	U		E	Clause 5: CPDLC_016, CPDLC_017, CPDLC_018.
4.1.2.17	ATM Data Processing System shall use 24 bit aircraft address from flight plan.	U		O	
4.1.2.18	CM ground AE shall comply with ED-110B [6].	U		E	Clause 5: CM_001, CM_002, CM_003, CM_004.
4.1.2.19	ATM Data Processing System shall not invoke CM-Update service for aircraft.	U		O	
4.1.2.20	ULCS implementations in ATM Data Processing System shall comply with ED-110B [6].	U		O	
4.1.2.21	Doc 9705 [4] shall be considered as including Technical Corrigendum 1 for ATN session protocol.	U		O	Declaration of Conformity or Declaration of Suitability for Use.
4.1.2.22	ATN session protocol implementations shall support listed SPDUs.	U		O	
4.1.2.23	Doc 9705 [4], clause 4.5.1.2 shall be considered without amendments for ATN presentation protocol.	U		O	Declaration of Conformity or Declaration of Suitability for Use.
4.1.2.24	ATN presentation protocol implementations shall support listed PPDUs.	U		O	
4.1.2.25	ICS implementations in ATM Data Processing System shall conform to ED-110B [6].	U		O	
4.1.2.26	ATM Data Processing System shall implement TP4 protocol as defined in Doc 9705 [4].	U		O	
4.1.2.27	ICS implementations in ATM Data Processing System shall incorporate defect resolutions to Doc 9705 [4].	C	It is up to the implementation to use it or not.	O	
4.1.2.31	WAN interconnections for LOF & NAN shall comply with OLDI spec.	U		O	
4.1.2.33	ATM Data Processing System shall check that 24 bit address from flight plan equals 24 bit address from LOF.	U		O	



Requirement of the present document		Requirement conditionality		Test specification	
Clause	Description	U/C	Condition	E/O	Reference
4.1.3	Data Link ground/ground and air/ground exchanges shall be recorded as defined in ED-111 [8].	U		O	
4.1.4.1	Ground HMI shall display Data Link messages and elicit controller inputs.	U		E	Clause 5: EE_001, ACL_001, ACL_002, ACL_003, ACL_004, ACL_005, ACL_006, ACL_007, ACL_008, AMC_001, AMC_002, ACM_001, ACM_002, ACM_003, ACM_004, ACM_005, ACM_006, ACM_007.
4.1.4.2	All DM shall be displayed to the controller as defined in ED-110B [6].	U		E	Clause 5: EE_001, ACL_001, ACL_002, ACL_003, ACL_004, ACL_005, ACL_006, ACL_007, ACL_008, AMC_001, AMC_002, ACM_001, ACM_002, ACM_003, ACM_004, ACM_005, ACM_006, ACM_007.
4.1.5.1	Air/Ground ATN routers shall comply with ED-110B [6], clauses 2 and 3.	U		O	Declaration of Conformity or Declaration of Suitability for Use.
4.1.5.2	Implementations of Air/Ground ATN routers shall incorporate defect resolutions to Doc 9705 [4].	C	It is up to the implementation to use it or not.	O	
4.1.5.3	ICS implementations in Air/Ground ATN routers shall conform to ED-110B [6].	U		O	Declaration of Conformity or Declaration of Suitability for Use.
4.1.5.4	Air/Ground ATN routers shall comply with class 5 as defined in Doc 9705 [4].	U		O	Declaration of Conformity or Declaration of Suitability for Use.
4.1.5.5	ICS implementations in Air/Ground ATN routers shall incorporate defect resolutions to Doc 9705 [4].	C	It is up to the implementation to use it or not.	O	Declaration of Conformity or Declaration of Suitability for Use.
4.1.5.6	Air/Ground ATN routers shall implement specified IDRP parameter setting.	C	It is up to the implementation to use it or not.	O	Declaration of Conformity or Declaration of Suitability for Use.
4.1.6.4	VDL Mode 2 ground physical- and MAC-layers shall comply with EN 301 841-1 [12].	U		O	Declaration of Conformity or Declaration of Suitability for Use.
4.1.6.1.1	ARINC 631 shall have precedence over ICAO VDL Mode 2 documents and over EN 301 841-2 [13].	U		O	Declaration of Conformity or Declaration of Suitability for Use.
4.1.6.3	All "M" functionalities for VDL Mode 2 ground stations in ARINC 631 [10] PICS shall be supported.	U		O	Declaration of Conformity or Declaration of Suitability for Use.
4.1.6.2.1	VDL Mode 2 service shall comply with ARINC 631 [10].	U		O	Declaration of Conformity or Declaration of Suitability for Use.
4.1.6.2.2	VDL Mode 2 shall be available and used for CPDLC and CM messages.	U		O	Declaration of Conformity or Declaration of Suitability for Use.
4.1.6.2.3	VDL Mode 2 frequency assignments shall comply with ICAO European rules.	U		O	
4.2.1	Performance requirements shall comply with ED-120 [7].	U		O	

Requirement of the present document		Requirement conditionality		Test specification	
Clause	Description	U/C	Condition	E/O	Reference
4.2.2	Safety requirements shall comply with ED-120 [7].	U		O	
4.2.3	DLIC, ACM, ACL and AMC services shall be implemented.	U		O	Clause 5: CM_001, CM_002, CM_003, CM_004, . ACL_001, ACL_002, ACL_003, ACL_004, ACL_005, ACL_006, ACL_007, ACL_008, , ACM_001, ACM_002, ACM_003, ACM_004, ACM_005, ACM_006, ACM_007, CPDLC_001, CPDLC_002, CPDLC_003, CPDLC_004, CPDLC_005, CPDLC_006, CPDLC_007, CPDLC_008, CPDLC_009, CPDLC_010, CPDLC_011, CPDLC_012, CPDLC_013, CPDLC_014, CPDLC_015, CPDLC_016, CPDLC_017, CPDLC_018, AMC_001, AMC_002.
4.2.3.1.1.1	DLIC implementations shall comply with ED-110B [6].	U		E	Clause 5: CM_001, CM_002, CM_003, CM_004.
4.2.3.1.1.2	ATM Data Processing System shall support DLIC contact and response to DLIC Logon.	U		E	Clause 5: CM_003, CM_004.
4.2.3.1.1.3	ATM Data Processing System shall store and process 24-bit aircraft address.	U		E	Clause 5: CPDLC_016.
4.2.3.1.1.4	ATM Data Processing System shall perform flightplan association before issuing a DLIC response.	U		E	Clause 5: CM_001, CM_002.
4.2.3.1.1.5	ATM Data Processing System shall verify that 24 bit address received from aircraft equals 24 bit address from flight plan before issuing a positive DLIC response.	U		E	Clause 5: CM_001, CM_002.
4.2.3.1.1.6	If LOF does not work, ATM Data Processing System shall use DLIC contact.	U		O	
4.2.3.1.2	DLIC implementations shall satisfy performance requirements of ED-120 [7].	U		O	
4.2.3.1.3	DLIC implementations shall satisfy safety requirements of ED-120 [7].	U		O	
4.2.3.2.1.1	Lack messages (DM100 & UM227) shall be used in ACM.	U		E	Clause 5: ACM_001, ACM_002, ACM_003, ACM_004, ACM_005, ACM_006, ACM_007.
4.2.3.2.1.2	ACM implementations shall comply with ED-110B [6].	U		E	Clause 5: ACM_001, ACM_002, ACM_003, ACM_004, ACM_005, ACM_006, ACM_007.
4.2.3.2.1.3	ACM implementations shall comply with case A as defined in ED-110B [6].	U		E	Clause 5: ACM_002.
4.2.3.2.1.4	ATM Data Processing System shall therefore send UM117 (or UM120) without UM135.	U		E	Clause 5: ACM_002.
4.2.3.2.2	ATM Data Processing System shall allow the sending of the listed UM for ACM.	See table 10		E	Clause 5: ACM_001, ACM_002, ACM_003, ACM_004, ACM_005, ACM_006, ACM_007.
4.2.3.2.2.1	UM183 when used for ACM shall be	U		E	Clause 5: ACM_003.

Requirement of the present document		Requirement conditionality		Test specification	
Clause	Description	U/C	Condition	E/O	Reference
	formatted as defined in ED-110B [6].				
4.2.3.2.3	ATM Data Processing System shall be able to receive and process the listed DM for ACM.	See table 11		E	Clause 5: ACM_001, ACM_002, ACM_003, ACM_004, ACM_005, ACM_006, ACM_007.
4.2.3.2.4	ACM implementations shall satisfy performance requirements of ED-120 [7].	U		O	
4.2.3.2.5	ACM implementations shall satisfy safety requirements of ED-120 [7].	U		O	
4.2.3.3.1	Lack messages (DM100 & UM227) shall be used in ACL.	U		E	Clause 5: ACL_001, ACL_002, ACL_003, ACL_004, ACL_005, ACL_006, ACL_007, ACL_008.
4.2.3.3.2	ATM Data Processing System shall allow the sending of the listed UM for ACL.	See table 12		E	Clause 5: ACL_001, ACL_002, ACL_003, ACL_004, ACL_005, ACL_006, ACL_007, ACL_008.
4.2.3.3.3	ATM Data Processing System shall be able to receive and process the listed DM for ACL.	See table 13		E	Clause 5: ACL_001, ACL_002, ACL_003, ACL_004, ACL_005, ACL_006, ACL_007, ACL_008.
4.2.3.3.6	ACL implementations shall satisfy performance requirements of ED-120 [7].	U		O	
4.2.3.3.7	ACL implementations shall satisfy safety requirements of ED-120 [7].	U		O	
4.2.3.3.7.1	SR-ACL-22 as defined in ED-120 [7] shall apply only to SO-ACM-4 and not to SO-ACL-15.	U		O	
4.2.3.4.1	AMC implementations shall comply with ED-110B [6].	U		E	Clause 5: AMC_001 or AMC_002.
4.2.3.4.2	ATM Data Processing System shall allow the sending of UM157 and UM183 for AMC.	C	UM157 shall be used in case UM183 is not, and vice versa.	E	Clause 5: AMC_001 or AMC_002.
4.2.3.4.3	When used in AMC, UM183 shall read "Check stuck microphone".	U		E	Clause 5: AMC_002.
4.2.3.4.4	AMC implementations shall satisfy performance requirements of ED-120 [7].	U		O	
4.2.3.4.5	AMC implementations shall satisfy safety requirements of ED-120 [7], except that for ATM Data Processing System SR-AMC-9 to SR-AMC-12 are not applicable.	U		O	
4.3.1	Operation of DLS shall comply with ICAO Doc 4444 [3] and Annex 10.	U		O	
4.3.3	When using voice for CPDLC, controller and pilot shall use phraseology of PANS-ATM.	U		O	
4.3.4	A controller shall wait execution of a clearance before issuing a 2nd one if the two are linked together.	U		O	
4.3.5	Letters of agreements between ATC units	U		O	

Requirement of the present document		Requirement conditionality		Test specification	
Clause	Description	U/C	Condition	E/O	Reference
	shall exist for ACM.				
4.3.6	ATN AE titles and ATN addresses shall be assigned in accordance with the DLS supported.	U		O	
4.3.7	ICAO facility designator shall be assigned to Ground ATC entities.	U		O	
4.3.8	National AIP shall include ground system addresses for DLIC Logon.	U		O	

---

## Annex D (informative): The EN title in the official languages

Language	EN title
Bulgarian	
Czech	
Danish	
Dutch	
English	Data Link Services (DLS) System; Community Specification for application under the Single European Sky Interoperability Regulation EC 552/2004 requirements for ground constituents and system testing
Estonian	
Finnish	
French	
German	
Greek	
Hungarian	
Icelandic	
Italian	
Latvian	
Lithuanian	
Maltese	
Norwegian	
Polish	
Portuguese	
Romanian	
Slovak	
Slovenian	
Spanish	
Swedish	

---

## Annex E (informative): Bibliography

- Directive 98/34/EC of the European Parliament and of the Council of 22 June 1998 laying down a procedure for the provision of information in the field of technical standards and regulations, OJ L 204, 21.07.1998 (modified by Directive 98/48/EC, OJ L 217, 05.08.1998).

---

## History

<b>Document history</b>			
V1.1.1	July 2010	Public Enquiry	PE 20101125: 2010-07-28 to 2010-11-25