

Draft **ETSI EN 303 135** V0.0.7 (2014-01)



Harmonized European Standard

**Electromagnetic compatibility and
Radio spectrum Matters (ERM); Coastal Surveillance,
Vessel Traffic Systems and Harbour Radars (CS/VTS/HR);
Harmonized EN covering the essential requirements
of article 3.2 of the R&TTE Directive**

Reference

DEN/ERM-TG26-107

Keywords

maritime, radar, regulation

ETSI

650 Route des Lucioles
F-06921 Sophia Antipolis Cedex - FRANCE

Tel.: +33 4 92 94 42 00 Fax: +33 4 93 65 47 16

Siret N° 348 623 562 00017 - NAF 742 C
Association à but non lucratif enregistrée à la
Sous-Préfecture de Grasse (06) N° 7803/88

Important notice

Individual copies of the present document can be downloaded from:

<http://www.etsi.org>

The present document may be made available in more than one electronic version or in print. In any case of existing or perceived difference in contents between such versions, the reference version is the Portable Document Format (PDF). In case of dispute, the reference shall be the printing on ETSI printers of the PDF version kept on a specific network drive within ETSI Secretariat.

Users of the present document should be aware that the document may be subject to revision or change of status. Information on the current status of this and other ETSI documents is available at

<http://portal.etsi.org/tb/status/status.asp>

If you find errors in the present document, please send your comment to one of the following services:

http://portal.etsi.org/chaicor/ETSI_support.asp

Copyright Notification

No part may be reproduced except as authorized by written permission.
The copyright and the foregoing restriction extend to reproduction in all media.

© European Telecommunications Standards Institute 2014.
All rights reserved.

DECT™, **PLUGTESTS™**, **UMTS™** and the ETSI logo are Trade Marks of ETSI registered for the benefit of its Members.
3GPP™ and **LTE™** are Trade Marks of ETSI registered for the benefit of its Members and
of the 3GPP Organizational Partners.
GSM® and the GSM logo are Trade Marks registered and owned by the GSM Association.

Contents

Intellectual Property Rights	5
Foreword.....	5
Introduction	5
1 Scope	6
2 References	7
2.1 Normative references	7
2.2 Informative references	7
3 Definitions, symbols and abbreviations	8
3.1 Definitions	8
3.2 Symbols	8
3.3 Abbreviations	9
4 Technical requirements	9
4.1 Environmental profile.....	9
4.2 Conformance requirements	9
4.2.1 Operating frequency	9
4.2.1.1 Definition	9
4.2.1.2 Limits	9
4.2.1.3 Conformance	10
4.2.2 Transmitter power.....	10
4.2.2.1 Definition	10
4.2.2.2 Limits	10
4.2.2.3 Conformance	10
4.2.3 Out-of-band emissions.....	10
4.2.3.1 Definition	10
4.2.3.2 Limits	12
4.2.3.3 Conformance	13
4.2.4 Spurious emissions	13
4.2.4.1 Definition	13
4.2.4.2 Limits	14
4.2.4.3 Conformance	14
4.3 Receiver requirements.....	15
4.3.1 Receiver Noise Figure	15
4.3.1.1 Limit.....	15
4.3.1.2 Conformance.....	15
4.3.2 Receiver Selectivity	15
4.3.2.1 Limit.....	15
4.3.2.2 Conformance.....	15
5 Testing for compliance with technical requirements.....	15
5.1 Environmental conditions for testing	15
5.2 Interpretation of the measurement results	15
5.3 Test conditions, power supply and ambient temperatures	16
5.3.1 Standard operating mode of the radar equipment	16
5.4 Normal and extreme test conditions	16
5.4.1 Introduction.....	16
5.4.2 Normal temperature and humidity	16
5.4.3 Normal test power supply	17
5.5 Essential radio test suites.....	17
5.5.1 Operating frequency	17
5.5.2 Transmitter power	17
5.5.3 Out-of-Band-emissions	17
5.5.4 Spurious emissions	19
5.5.5 System Noise Figure	19
5.5.6 Receiver Selectivity	20

5.5.6.1	Receiver Out-of-Band selectivity	20
5.5.6.2	Receiver spurious response rejection	21
Annex A (normative):	HS Requirements and conformance Test specifications Table (HS-RTT).....	22
Annex B (normative):	Transmission power and unwanted emissions of radar systems with indirect methods.....	24
Annex C (informative):	Bibliography.....	25
History		26

Intellectual Property Rights

IPRs essential or potentially essential to the present document may have been declared to ETSI. The information pertaining to these essential IPRs, if any, is publicly available for **ETSI members and non-members**, and can be found in ETSI SR 000 314: "*Intellectual Property Rights (IPRs); Essential, or potentially Essential, IPRs notified to ETSI in respect of ETSI standards*", which is available from the ETSI Secretariat. Latest updates are available on the ETSI Web server (<http://ipr.etsi.org>).

Pursuant to the ETSI IPR Policy, no investigation, including IPR searches, has been carried out by ETSI. No guarantee can be given as to the existence of other IPRs not referenced in ETSI SR 000 314 (or the updates on the ETSI Web server) which are, or may be, or may become, essential to the present document.

Foreword

This draft Harmonized European Standard (EN) has been produced by ETSI Technical Committee Electromagnetic compatibility and Radio spectrum Matters (ERM), and is now submitted for the combined Public Enquiry and Vote phase of the ETSI standards EN Approval Procedure.

The present document has been produced by ETSI in response to mandate M/284 issued from the European Commission issued under Directive 98/34/EC [i.8] as amended by Directive 98/48/EC [i.10].

The title and reference to the present document are intended to be included in the publication in the Official Journal of the European Union of titles and references of Harmonized Standard under the Directive 1999/5/EC [i.1].

See article 5.1 of Directive 1999/5/EC [i.1] for information on presumption of conformity and Harmonised Standards or parts thereof the references of which have been published in the Official Journal of the European Union.

The requirements relevant to Directive 1999/5/EC [i.1] are summarised in annex A.

Proposed national transposition dates	
Date of latest announcement of this EN (doa):	3 months after ETSI publication
Date of latest publication of new National Standard or endorsement of this EN (dop/e):	6 months after doa
Date of withdrawal of any conflicting National Standard (dow):	18 months after doa

Introduction

The present document intends to present a harmonized way of proving compliance to the essential requirements of the R&TTE directive for other important types of radar like Coastal Surveillance (CS), Vessel Traffic Systems (VTS) and possibly harbour radars.

The emission limits implemented arise from ECC/Recommendation (02)05 (2012) [i.4] and ERC/Recommendation 74-01 (2011) [i.5].

The test methods used arise from Recommendation ITU-R M.1177-4 (2011) [i.7] and Recommendation ITU-R SM.1541-4 (2011) [1].

NOTE: The present document is closely related to EN 303 213-6-1 [i.13] which covers essential requirements for radars used in airport SMCGS systems, but which use largely the same type of radar technology.

The present document is part of a set of standards developed by ETSI and is designed to fit in a modular structure to cover all radio and telecommunications terminal equipment within the scope of the R&TTE Directive [i.1]. The modular structure is shown in EG 201 399 [i.9].

1 Scope

The present document applies to X-band radar sensors intended for use in Vessel Traffic Systems (VTS), Coastal Surveillance (CS) or Harbour Radar Systems with the following characteristics:

- Utilizing modulated or unmodulated pulses.
- Transmitter Peak Envelope Power up to 100 kW.
- The transceiver-antenna connection is using a hollow metallic rectangular waveguide.
- The antenna is rotating, waveguide- based and passive.
- At the transceiver output an RF-circulator is used.

NOTE 1: Since transceiver and antenna are hollow metallic rectangular waveguide based, the frequency range for measurements that needs to be addressed covers 6,56 GHz to 26 GHz. The lower limit of this frequency range is obtained as cut-off frequency of the combination of WR112/R84 taper section and a WR90/R100 Waveguide as defined by IEC 60153-2 [i.3]. The upper limit corresponds to the upper limit stated in ERC/Recommendation 74-01 [i.5]. Other types of waveguide may be used by the same principles to obtain complete measurement coverage of the frequency range of the output flange of the equipment under test.

NOTE 2: Since at the transceiver output an RF circulator is used, it is assumed that the transceiver characteristics remain independent from the antenna.

NOTE 3: According to Article 5 of the ITU Radio Regulations [i.6] there are a number of bands between 8,5 GHz and 10 GHz that are allocated to Radiolocation service. There are national deviations to the detailed band usages, but the basic spectrum usage regulation is the same.

Table 1: Radiolocation service frequency bands [GHz]

8 500-8 550
8 550-8 650
8 650-8 750
8 750-8 850
8 850-9 000
9 000-9 200
9 200-9 300
9 300-9 500
9 500-9 800
9 800-9 900
9 900-10 000

The present document is intended to cover the provisions of Directive 1999/5/EC [i.1] (R&TTE Directive), article 3.2, which states that "... *radio equipment shall be so constructed that it effectively uses the spectrum allocated to terrestrial/space radio communications and orbital resources so as to avoid harmful interference*".

In addition to the present document, other ENs that specify technical requirements in respect of essential requirements under other parts of Article 3 of the R&TTE Directive [i.1] may apply to equipment within the scope of the present document.

NOTE: A list of such ENs is included on the web site <http://www.newapproach.org>.

2 References

References are either specific (identified by date of publication and/or edition number or version number) or non-specific. For specific references, only the cited version applies. For non-specific references, the latest version of the reference document (including any amendments) applies.

Referenced documents which are not found to be publicly available in the expected location might be found at <http://docbox.etsi.org/Reference>.

NOTE: While any hyperlinks included in this clause were valid at the time of publication ETSI cannot guarantee their long term validity.

2.1 Normative references

The following referenced documents are necessary for the application of the present document.

- [1] Recommendation ITU-R SM.1541-4 (2011): "Unwanted emissions in the out-of-band domain".

2.2 Informative references

The following referenced documents are not necessary for the application of the present document but they assist the user with regard to a particular subject area.

- [i.1] Directive 1999/5/EC of The European Parliament and of the Council of 9 March 1999 on radio equipment and telecommunications terminal equipment and the mutual recognition of their conformity (R&TTE Directive).
- [i.2] Merrill I. Skolnik: "Radar Handbook", 2nd Edition, McGraw Hill publications.
- [i.3] IEC 60153-2 (Edition 2.0, 1974): "Hollow metallic waveguides. Part 2: Relevant specifications for ordinary rectangular waveguides".
- [i.4] ECC/Recommendation (02)05 (2012): "Unwanted emissions".
- [i.5] ERC/Recommendation 74-01 (2011): "Unwanted emissions in the spurious domain".
- [i.6] ITU Radio Regulations 2012.
- [i.7] Recommendation ITU-R M.1177-4 (2011): "Techniques for measurement of unwanted emissions of radar systems".
- [i.8] Directive 98/34/EC of the European Parliament and of the Council laying down a procedure for the provision of information in the field of technical standards and regulations and of rules on information society services.
- [i.9] ETSI EG 201 399: "Electromagnetic compatibility and Radio spectrum Matters (ERM); A guide to the production of Harmonized Standards for application under the R&TTE Directive".
- [i.10] Directive 98/48/EC of the European Parliament and of the Council of 20 July 1998 amending Directive 98/34/EC laying down a procedure for the provision of information in the field of technical standards and regulations.
- [i.11] ETSI TR 100 028 (all parts) (V1.4.1) (12-2001): "Electromagnetic compatibility and Radio spectrum Matters (ERM); Uncertainties in the measurement of mobile radio equipment characteristics".
- [i.12] ETSI TR 100 028-2 (V1.4.1) (12-2001): "Electromagnetic compatibility and Radio spectrum Matters (ERM); Uncertainties in the measurement of mobile radio equipment characteristics; Part 2".

- [i.13] ETSI EN 303 213-6-1: "Advanced Surface Movement Guidance and Control System (A-SMGCS); Part 6: Harmonized EN covering the essential requirements of article 3.2 of the R&TTE Directive for deployed surface movement radar sensors; Sub-part 1: X-band sensors using pulsed signals and transmitting power up to 100 kW".

3 Definitions, symbols and abbreviations

3.1 Definitions

For the purposes of the present document, the following terms and definitions apply:

necessary bandwidth: width of the frequency band which is just sufficient to ensure the transmission of information at the rate and with the quality required under specified conditions

NOTE: This definition is taken from ITU Radio Regulation No. 1.152 [i.6] and it applies to a given class of emission.

occupied bandwidth: width of a frequency band such that, below the lower and above the upper frequency limits, the mean powers emitted are each equal to a specified percentage $\beta/2$ of the total mean power of a given emission

NOTE 1: Unless otherwise specified in a Recommendation ITU-R for the appropriate class of emission, the value of $\beta/2$ should be taken as 0,5 %.

NOTE 2: This definition is taken from ITU Radio Regulation No. 1.153 [i.6].

peak envelope power: average power supplied to the antenna transmission line by a transmitter during one radio frequency cycle at the crest of the modulation envelope taken under normal operating conditions

NOTE: This definition is taken from ITU Radio Regulation No. 1.157 [i.6]).

pulse duration: time between the 50 % amplitude (voltage) points

pulse rise time: time taken for the leading edge of the pulse to increase from 10 % to 90 % of the maximum amplitude (voltage)

3.2 Symbols

For the purposes of the present document, the following symbols apply:

B_{-40}	-40 dB bandwidth
B_C	Chirp bandwidth
B_N	Necessary bandwidth
B_{res}	3 dB resolution bandwidth of transceiver
dB_{pp}	dB with respect to peak power
$D_{no\ spur}$	Detectability Factor (function of PD & Pfa)
k	Boltzmann's constant
MDS	Minimum Detectable Signal
NF_{sys}	Noise Figure of the system
PD	Probability of detection
PEP	Peak Envelope Power
Pfa	Probability of false detection
P_t	Pulse power of transmission
t	Time
t_p	Pulse duration
t_r	Pulse rise time
T_0	Temperature in Kelvin
T_C	Chirp length in seconds
λ	Wavelength

3.3 Abbreviations

For the purposes of the present document, the following abbreviations apply:

AC	Alternating Current
CS	Coastal Surveillance
FM-CW	Frequency Modulated Continuous Wave
LNA	Low Noise Amplifier
OoB	Out-of-Band
R&TTE	Radio and Telecommunication Terminal Equipment
SMR	Surface Movement Radar
VTS	Vessel Traffic Systems
SMGCS	Surface Movement Guidance and Control System
RF	Radio Frequency
PEP	Peak Envelope Power
FM	Frequency Modulation
MDS	Minimum Detectable Signal

4 Technical requirements

4.1 Environmental profile

The technical requirements of the present document apply under the environmental profile for operation of the equipment, which shall be stated by the manufacturer.

The equipment shall comply in any of the operating modes with all the technical requirements of the present document at all times when operating within the boundary limits of the stated operational environmental profile.

4.2 Conformance requirements

4.2.1 Operating frequency

4.2.1.1 Definition

The transmitter of a pulsed radar produces microwave pulses, which cause a broad frequency spectrum, depending on the pulse duration.

The operating frequency is to be understood as the frequency of the microwave emission during the transmitting pulse and is represented by the spectral line of highest amplitude.

NOTE: It is only practicable to indicate an operating frequency for radars with unmodulated pulses. In this case a limit for the frequency tolerance is specified. For radars with modulated pulses such a limit is not applicable. In any case the occupied bandwidth is completely contained in the allocated frequency band(s).

4.2.1.2 Limits

The limit for the frequency tolerance applying unmodulated pulses is ± 30 MHz.

For all radar types covered by the present documents the occupied bandwidth of the signal shall be contained completely within the allocated band in use (e.g. 9 200 MHz to 9 500 MHz) in all operating modes.

4.2.1.3 Conformance

Conformance tests as defined in clause 5.3.1 shall be carried out.

4.2.2 Transmitter power

4.2.2.1 Definition

The transmitter power shall be referenced with respect to the output port of the radar transmitter.

The transmitter power of a pulse radar is understood to be the peak pulse envelope (PEP see [i.6] 1.157) power during the transmitted pulse.

If the transmitter power can be varied according to azimuth, the highest PEP value measured during a period equal to at least one rotation period shall be used.

4.2.2.2 Limits

The transmitter power shall be as specified by the manufacturer with an accuracy of at least ± 2 dB under normal operating conditions. The peak power value shall not exceed 100 kW (50 dBW).

4.2.2.3 Conformance

Conformance tests as defined in clause 5.3.2 shall be carried out.

4.2.3 Out-of-band emissions

4.2.3.1 Definition

An important parameter of the Out-of-Band (OoB) emissions mask of the radar is the -40 dB bandwidth. Annex 8 of Recommendation ITU-R SM.1541-4 [1] specifies the -40 dB bandwidth specified for various types of waveforms (e.g. pulsed radar signals). With the following assumptions which apply to most airport surface movement radars these specifications can be further simplified:

- the radar is operating in a band within the limits 8 500 MHz to 10 000 MHz;
- the pulse power is below 100 kW;
- the pulse rise time t_r is greater than $0,0094 \cdot t$, where t is the pulse duration.

With the aforementioned assumptions the -40 dB bandwidth (B_{-40}) for primary non-FM pulse radars can be determined as follows:

$$B_{-40} = \frac{7.6}{\sqrt{t \times t_r}}$$

Where:

t is the pulse duration

t_r is the rise time in the case of a trapezoidal pulse

NOTE: For typical values of a pulse duration of $t = 50$ ns and a rise time of $t_r = 10$ ns the formula above yields a -40 dB bandwidth value of 340 MHz.

For radars with multiple pulse waveforms, the B_{-40} bandwidth should be calculated for each individual pulse type and the maximum B_{-40} bandwidth obtained shall be used to establish the shape of the emission mask.

For radars with a highly asymmetrical spectrum, the B_{-40} dB bandwidth can be offset from the frequency of maximum emission level, but the necessary bandwidth, B_N and preferably the overall occupied bandwidth should be contained completely within the allocated band as stipulated in section 4 of Annex 8 of Recommendation ITU-R SM.1541-4 [1].

The application of this rule is illustrated in figure 1.

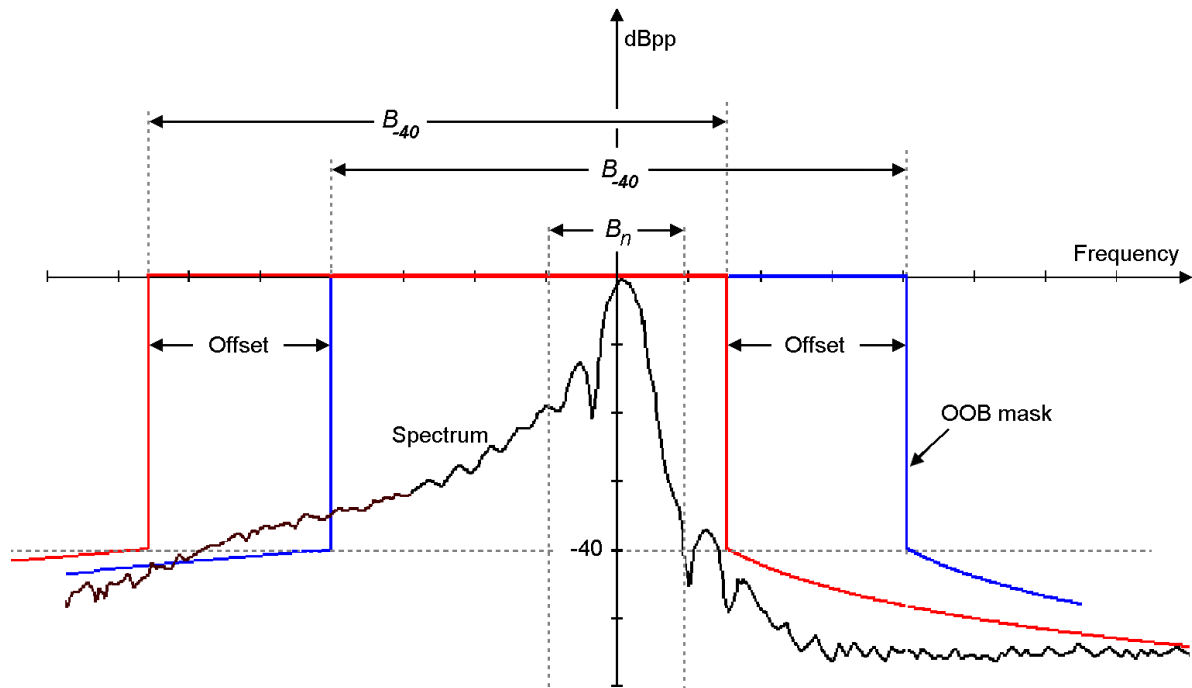

Figure 1: Application of the offset-rule for the Out-of-Band emission limit mask

For FM pulsed radars the B_{-40} can be calculated as follows:

$$B_{-40} = 1.5 \cdot \left\{ B_C + \sqrt{\pi} \cdot [\ln(B_C \cdot \tau)]^{0.53} \cdot \left[\text{Min}(B_{rise}, B_{fall}, B_{rise\&fall}) + \text{Max}(B_{rise}, B_{fall}, B_{rise\&fall}) \right] \right\} + B_S$$

where

$$B_{rise} = \frac{1}{\sqrt{\tau \cdot t_r}}$$

$$B_{fall} = \frac{1}{\sqrt{\tau \cdot t_f}}$$

$$B_{rise\&fall} = \frac{1}{\sqrt[3]{\tau \cdot t_f \cdot t_r}}$$

Where:

B_{-40} is the -40dB bandwidth in Hz

B_C is the bandwidth of the frequency deviation (total frequency shift during the pulse generation)

B_S is the maximum range over which the carrier frequency will be shifted, B_S equals zero for non-frequency hopping cases. It is zero in case of a single carrier frequency

τ is the pulse length including rise & fall times

t_r is the risetime in seconds

t_f is the falltime in seconds

B_C is the chirp bandwidth in Hz

B_S is the maximum range over which the carrier frequency is shifted

For systems with multiple carriers, the OoB domain should start at the edges of the total assigned bandwidth. This means that the effective B_{-40} is from the lower end of the calculated B_{-40} of the lowest radar frequency to the high end of the B_{-40} for the highest radar frequency.

4.2.3.2 Limits

The Out-of-Band emission limits and the spurious emission limits are defined based on the -40 dB bandwidth.

The maximum radiated Out-of-Band emission power level shall not exceed the limits stated in table 2 and the corresponding mask depicted in figure 2. The roll-off of the OoB-mask beyond the -40 dB bandwidth, B_{-40} in relation to B_{-40} is specified as follows:

- The mask has a roll-off at 20 dB/dec from the calculated (identified) B_{-40} bandwidth to a level of -60 dBpp. The mask then continues to roll-off at 60 dB/dec to a spurious emission limit level of -100 dBpp.

NOTE 1: This mask corresponds to the limit specification in Annex 2 of i.e. the dashed line in Figure A2.1c of ECC/Recommendation (02)05 [i.4].

- If an absolute limit of -30 dBm can be more easily achieved this limit applies in lieu of -100 dBpp.

NOTE 2: ERC/Recommendation 74-01 [i.5] stipulates in its Table 1 for fixed radars a spurious emission limit in the reference bandwidth of "-30 dBm or 100 dB, whichever is less stringent".

Table 2: Limits for unwanted emissions

Frequency offset relative to B_{-40}	Limit dBpp	Slope dB/decade
0 to 0,5	0	0
0,5	-40	$-\infty$
0,5 to 5	-40 to -70	-30
5 to 15,8	-70 to -100/-30 dBm	-60
15,8 to ∞	-100/-30 dBm	0

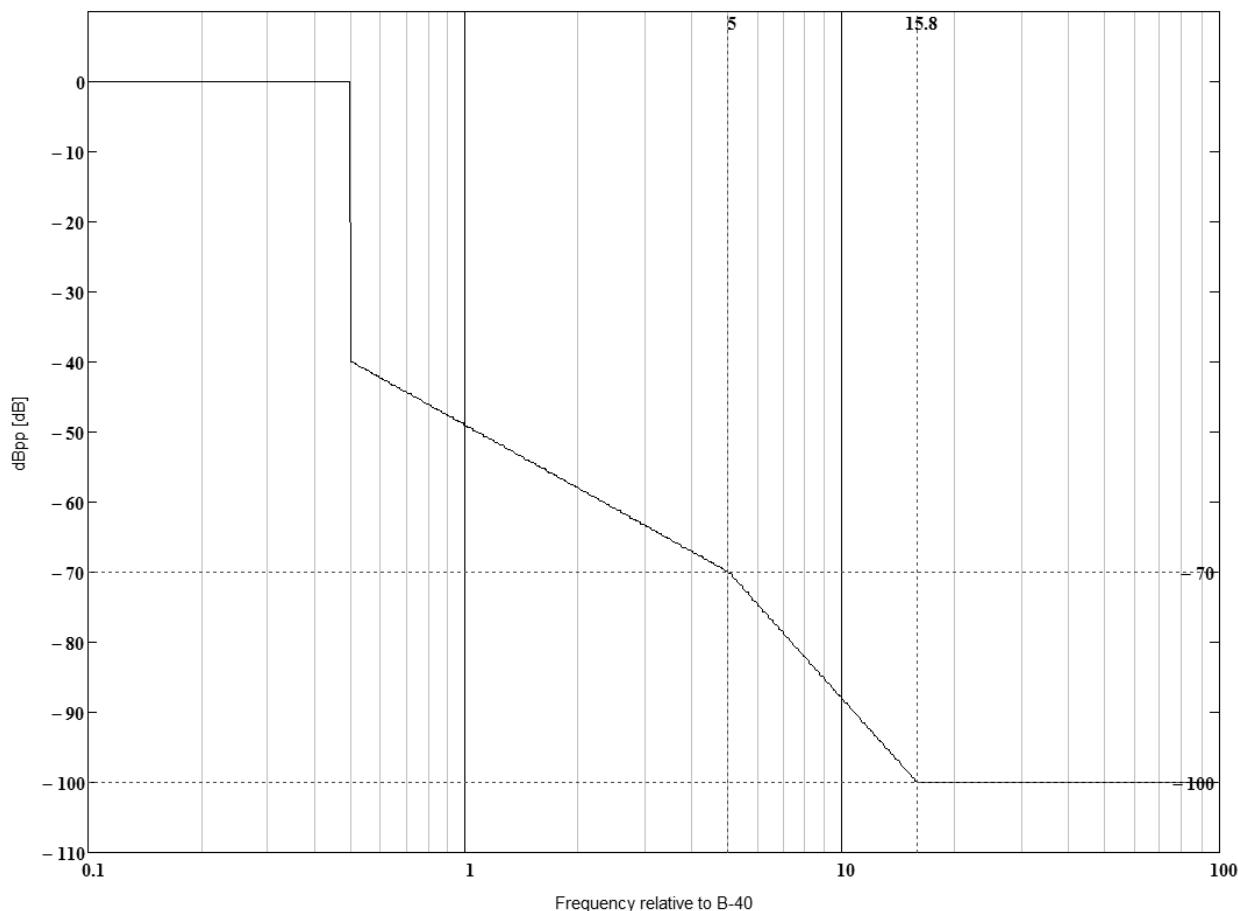

Figure 2: Out-of-Band emission limit masks

4.2.3.3 Conformance

Conformance tests as defined in clause 5.3.3 shall be carried out.

4.2.4 Spurious emissions

4.2.4.1 Definition

Spurious emissions are defined as the entity of all emissions in the frequency range of the cut-off frequency 6,56 GHz of the waveguide section to 26 GHz, but outside the OoB-boundaries.

NOTE: The lower limit of this frequency range of 6,56 GHz is obtained as cut-off frequency of the combination of WR112/R84 taper section and a WR90/R100 Waveguide as defined in IEC 60153-2 [i.3]. The upper limit corresponds to the upper limit stated in ERC/Recommendation 74-01 [i.5].

They include:

- harmonic emissions (whole multiples of the operating frequency);
- parasitic emissions (independent, accidentally);
- intermodulation (between oscillator- and operation frequency or between oscillator and harmonics);
- emissions caused by frequency conversions.

The boundaries between OoB domain and the spurious domain are where the OoB limit mask specified in ECC/Recommendation (02)05 [i.4] reach the spurious emission limit of -100 dBpp according to ERC/Recommendation 74-01 [i.5]. This is illustrated in figure 3.

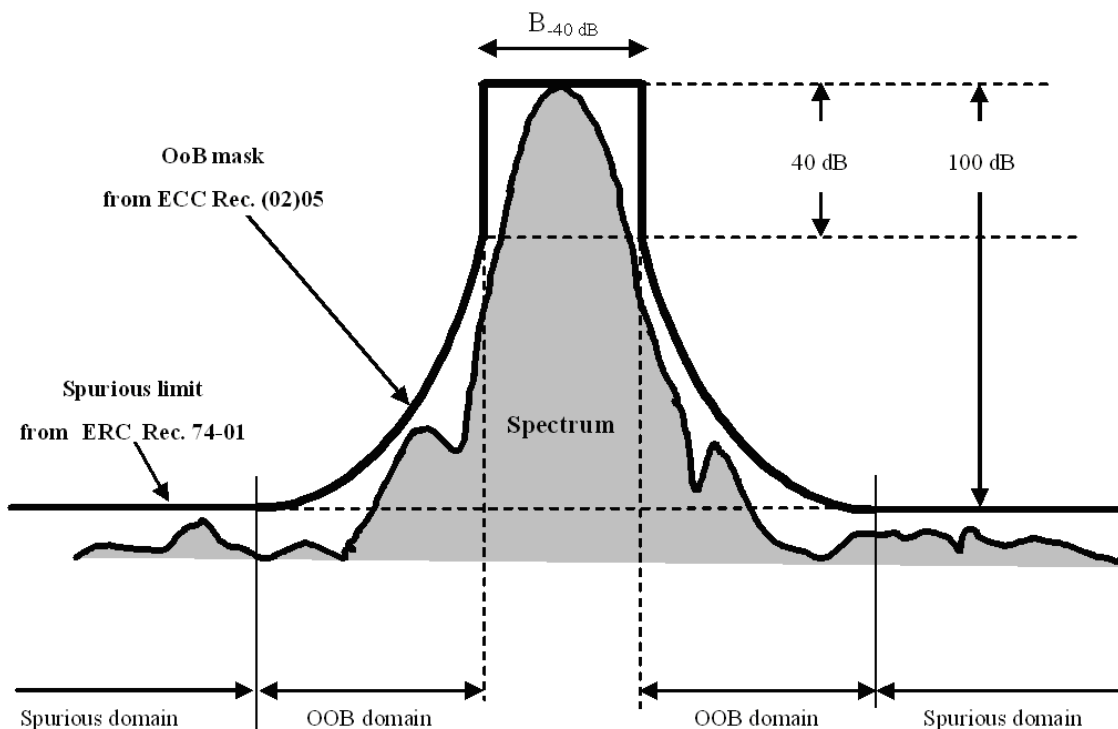

**Figure 3: Definition of OoB and spurious emission domains
(Not to scale)**

4.2.4.2 Limits

NOTE 1: In a future version of the present document more stringent requirements for OoB Emissions based on the design objective case in ECC/Recommendation (02)05 [i.4] (of i.e. the solid line in Figure A2.1c with a slope of 40 dB+/decade) may need to be considered.

For the spurious emissions the following requirement based on Table 5.1 in Annex 5 for the case of fixed stations in ERC/Recommendation 74-01 [i.5] applies:

- All spurious emission levels radar equipment shall have:
 - a minimum attenuation of 100 dB or a maximum power -30 dBm, whichever is less stringent;
 - measured as PEP in the reference bandwidth of 1 MHz.

NOTE 2: A reference bandwidth of 1 MHz is recommended for frequencies above 1 GHz as in ERC/Recommendation 74-01 [i.5].

NOTE 3: In the case of occurrence of interferences caused by unwanted emissions of the radar system much higher suppression of Out-of-Band or spurious emissions may be required! Therefore it is desirable that it is possible to attenuate or to suppress parts of the emitted signal in the feeder line.

4.2.4.3 Conformance

Conformance tests as defined in clause 5.3.4 shall be carried out.

4.3 Receiver requirements

4.3.1 Receiver Noise Figure

4.3.1.1 Limit

The maximum system Noise Figures shall be 6 dB.

4.3.1.2 Conformance

The conformance tests as defined in clause 5.5.5 shall be carried out.

4.3.2 Receiver Selectivity

4.3.2.1 Limit

The input selectivity characteristic of the SMR receiver shall be commensurate with the requirements for the spectrum of the emitted signal.

4.3.2.2 Conformance

The conformance tests as defined in clause 5.5.5 shall be carried out.

5 Testing for compliance with technical requirements

5.1 Environmental conditions for testing

Tests defined in the present document shall be carried out at representative points within the boundary limits of the declared operational environmental profile.

Where technical performance varies subject to environmental conditions, tests shall be carried out under a sufficient variety of environmental conditions (within the boundary limits of the declared operational environmental profile) to give confidence of compliance for the affected technical requirements.

5.2 Interpretation of the measurement results

The interpretation of the results recorded in a test report for the measurements described in the present document shall be as follows:

- the measured value related to the corresponding limit will be used to decide whether an equipment meets the requirements of the present document;
- the value of the measurement uncertainty for the measurement of each parameter shall be included in the test report;
- the recorded value of the measurement uncertainty shall be, for each measurement, equal to or lower than the figures in table 3.

For the test methods, according to the present document, the measurement uncertainty figures shall be calculated and shall correspond to an expansion factor (coverage factor) $k = 1,96$ or $k = 2$ (which provide confidence levels of respectively 95 % and 95,45 % in the case where the distributions characterising the actual measurement uncertainties are normal (Gaussian)). Principles for the calculation of measurement uncertainty are contained in TR 100 028 [i.11], in particular in annex D of the TR 100 028-2 [i.12].

Table 3 is based on such expansion factors.

Table 3: Absolute measurement uncertainties: maximum values

Parameter	Uncertainty
RF Frequency	1×10^{-6}
RF pulse power	$\pm 1,5$ dB
Noise Figure	$\pm 0,6$ dB

5.3 Test conditions, power supply and ambient temperatures

5.3.1 Standard operating mode of the radar equipment

For the purpose of the compliance tests described in the present document, the radar under test shall be set up in a realistic operation mode. This means that the transceiver shall be operating and set-up with parameters which produce the worst-case spectrum (e.g. shortest pulse length, highest peak frequency deviation). Furthermore, the radar shall be supplied with the necessary signals (e.g. antenna azimuth encoder signal, safety loop signals) to simulate normal operation.

NOTE: The standard operating parameters depend very much on the type of the radar.

In the test-report the mode of operation applied for the tests shall be documented. The test-report shall also explain the reason why this mode (setup) has been chosen.

5.4 Normal and extreme test conditions

5.4.1 Introduction

Unless otherwise stated in the test procedures for essential radio test suites, the tests defined in the present document shall be carried out at representative points within the boundary limits of the declared operational environmental profile (see clause 5.3.1).

Where technical performance varies subject to environmental conditions, tests shall be carried out under a sufficient variety of environmental conditions (within the boundary limits of the declared operational environmental profile) to give confidence of compliance for the affected technical requirements.

5.4.2 Normal temperature and humidity

The normal temperature and humidity conditions for tests shall be a combination of temperature and humidity within the following ranges:

- a) temperature: +15 °C to +25 °C;
- b) relative humidity: 20 % to 75 %.

Actual values shall be stated in the test report.

5.4.3 Normal test power supply

The test voltage for equipment to be connected to an AC supply shall be the nominal mains voltage declared by the manufacturer -10 % to +10 %. For the purpose of the present document, the nominal voltage shall be the declared voltage or each of the declared voltages for which the equipment is indicated as having been designed. The frequency of the test voltage shall be $50 \text{ Hz} \pm 1 \text{ Hz}$.

5.5 Essential radio test suites

5.5.1 Operating frequency

These measurements shall be performed under both normal and extreme test conditions as declared by manufacturer.

The antenna shall be replaced by a suitable adapter to adapt the rotary joint to a waveguide with a plane flange. On that flange a high-power directional coupler will be mounted with its main port terminated by a matching high-power dummy load. The coupled port shall have an adequate attenuation within the whole frequency band 8 500 MHz to 10 000 MHz (400 MHz outside edges of allocated bands) to protect the measurement equipment.

To measure and display the spectrum of the transmitted signal a suitable spectrum analyser shall be used. The acquisition time for the spectrum shall be at least 60 seconds. The spectrum shall be measured in the maximum hold mode of the spectrum analyzer.

The results obtained shall be compared to the limits in clause 4.2.1.2 in order to prove compliance with the requirement.

To measure the frequency stability a spectrum analyzer with a frequency stability of equal or better 10 ppm is connected to the SMR transmitter via suitable couplers. In this way the deviation of the emission peak frequency from the specified frequency is measured.

5.5.2 Transmitter power

These measurements shall be performed under both normal and extreme test conditions as declared by manufacturer.

The antenna shall be replaced by a suitable adapter to adapt the rotary joint to a waveguide with a plane flange. On that flange a high-power directional coupler will be mounted with its main port terminated by a matching high-power dummy load. The coupled port shall have a sufficient attenuation within the whole frequency band 8 500 MHz to 10 000 MHz to avoid saturation of the measurement equipment. The coupling factor shall be known in the allocated band with an accuracy of 0,5 dB.

To determine the Peak Envelope Power (PEP) of the pulse a suitable pulse power meter with direct reading of the transmitter pulse power shall be used.

To reference the indicated transmitter power to the transmitter output flange the coupling factor shall be taken into account. If the power meter does not allow for compensation of the coupling loss, then the coupling loss shall be added to the meter reading.

The results obtained shall be compared to the limits in clause 4.2.2.2 in order to prove compliance with the requirement.

5.5.3 Out-of-Band-emissions

These measurements shall be performed under normal test conditions.

The so-called indirect method shall be applied for the measurement of unwanted emissions of radar systems. At first the transmitter output spectrum is measured with removed antenna at the output port of the transmitter as illustrated in figure B.1. In order to obtain a sufficient dynamic range the radar signal shall be suppressed by an additional notch-filter.

Further information how to perform the measurement can be found in Recommendation ITU-R M.1177-4 [i.7]. The Out-of-Band power emission shall be measured in the frequency bands given in table 4. The results obtained shall be compared to the limits in clause 4.2.3.2 and depicted as given in figure 2 in order to prove compliance with the requirement.

NOTE 1: These OoB boundaries are taken from ECC/Recommendation (02)05 [i.4].

Table 4: Out-of-Band emissions boundaries

Lower OoB boundary	Upper OoB boundary
Carrier frequency $-15,8 B_{-40}$	Carrier frequency $+ 15,8 B_{-40}$

NOTE 2: Example radar parameters are e.g. a centre frequency of 9,1 GHz, a pulse duration of $t = 50$ ns and a rise time of $t_r = 10$ ns, the 40 dB bandwidth calculated applying the equation from clause 4.2.1.1 is 340 MHz. This leads to OoB boundaries at $15,8 \times 340$ MHz = 5,372 GHz away from the centre frequency (figure 4). For this example the absolute boundaries between out-of-band emission and spurious emission are:

$$9,1 \text{ GHz} - 5,372 \text{ GHz} = 3,728 \text{ GHz} \text{ and } 9,1 \text{ GHz} + 5,372 \text{ GHz} = 14,472 \text{ GHz} \text{ (figure 5).}$$

Figures 4 and 5 depict the calculated emission masks for the aforementioned parameters of an example radar applying the mask specification in clause 4.2.3.2 which corresponds to the standard mask in Figure A2.1c of ECC/Recommendation (02)05 [i.4].

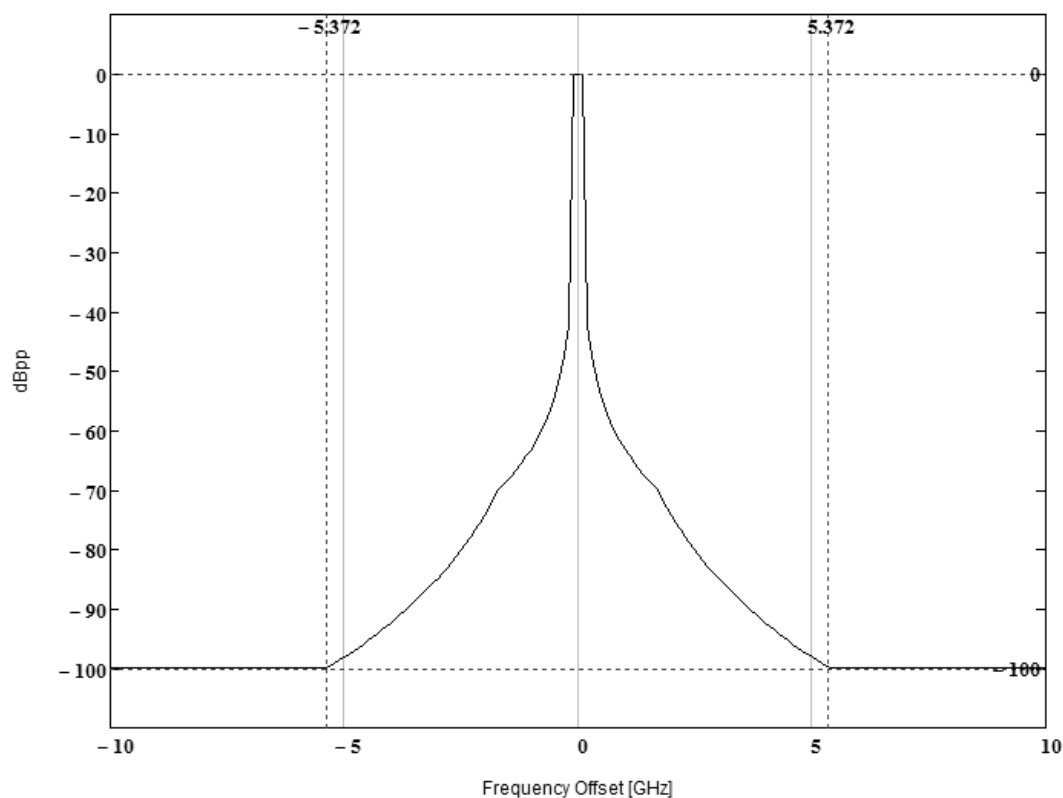

Figure 4: Theoretical emissions mask for typical pulse duration of $t = 50$ ns and rise time of $t_r = 10$ ns

NOTE 3: Measurements below the cutoff frequency 6,56 GHz are irrelevant as the waveguide will not conduct such frequencies to the antenna.

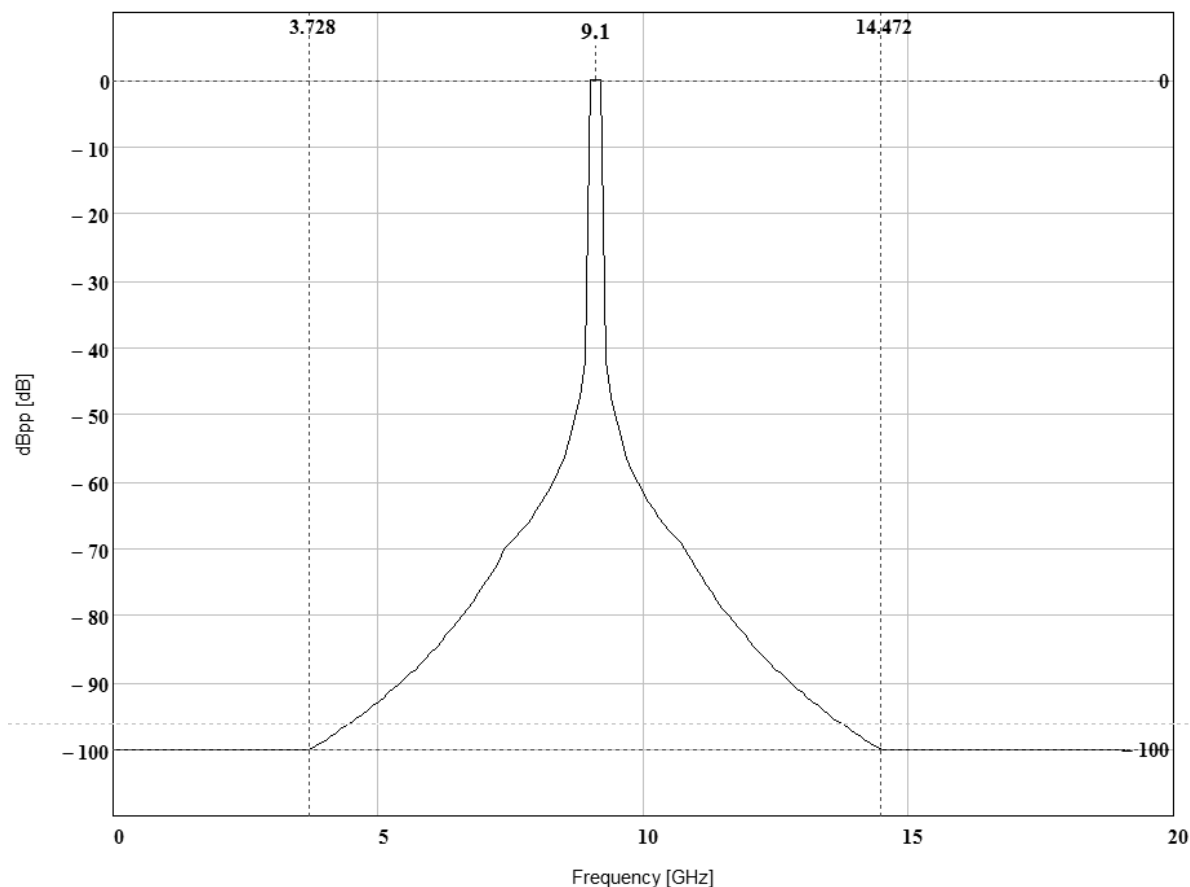

Figure 5: Calculated emissions mask for pulse duration of $t = 50$ ns and rise time of $t_r = 10$ ns at centre frequency of 9,1 GHz

5.5.4 Spurious emissions

These measurements shall be performed under normal test conditions.

For the spurious emission measurements the aforementioned indirect method shall be used. To perform the measurement the radar and the measuring equipment shall be installed as displayed in figure B.1. The spurious power emission shall be measured in frequency ranges outside the Out-of-Band emissions boundaries.

If required to reach a dynamic amplitude measuring range of 110 dB minimum, a Low Noise Amplifier (LNA) and a notch filter for the operating frequency should be used.

The results obtained shall be compared to the limits in clause 4.2.4.2 in order to prove compliance with the requirement.

Table 5: Spurious emissions measurement bands

Lower measurement band	Upper measurement band
From 6,56 GHz to the lower OoB boundary	From the upper OoB boundary to 26 GHz

5.5.5 System Noise Figure

These measurements shall be performed under both normal and extreme test conditions as declared by manufacturer.

The system noise figure is measured along the complete receiving signal chain (as close as possible, but excluding antenna, waveguide, and noise processing). It shall be measured using a noise source (which may be built into the system) and a detector (which may be built into the system as well).

One recommended measurement method for the System Noise Figure is the Y-factor method. A noise source is connected in lieu of the antenna to the radar receiver input port. The System Noise Figure is then determined from the ratio between the noise power values at output of the intermediate frequency stage (or its digitized equivalent) with noise source on and noise source off.

Other equivalent methods to establish the System Noise Figure are also acceptable.

5.5.6 Receiver Selectivity

These measurements shall be performed under normal test conditions.

Compliance is tested by calculating the Minimum Detectable Signal (MDS) level of the receiver at the transmission frequency:

$$MDS = kT_0 B_{res} NF_{sys} D_{no spur} \frac{1}{T_C B_C} M$$

Where:

MDS	Minimum Detectable Signal
k	Boltzmann constant
T_0	Temperature in Kelvin
B_{res}	3 dB resolution bandwidth of transceiver
NF_{sys}	Noise Figure of the system
$D_{no spur}$	Detectability Factor (function of P_D & P_{fa}) = 0,1

NOTE: The value of 0,1 for $D_{no spur}$ is taken from Figure 2.3 of "Radar Handbook" [i.2].

P_D	Probability of detection = 10^{-3} (selected value)
P_{fa}	Probability of false detection = 10^{-3} (selected value)
T_C	Chirp length in sec
B_C	Chirp bandwidth
M	Test margin = 0,1 (Without this margin the receiver should give a detectable signal)

The factor $1/(T_C B_C) = 1$ is applicable for a simple pulse radar.

5.5.6.1 Receiver Out-of-Band selectivity

These measurements shall be performed under normal test conditions.

In order to satisfy the requirement for efficient use of spectrum ([i.9] section C4) the receiver selectivity shall match the requirements for the emitted spectrum.

A disturbance signal level at MDS level plus the required attenuation shall be applied at the antenna flange in order to determine if the receiver selectivity follows the required emission mask.

EXAMPLE: A typical MDS is + 40 dB, which is applied at the end points of $B_{.40}$. In such a case a maximum disturbance signal strength of -30 dBm is used in order to simulate another transmitter's spurious level transmissions.

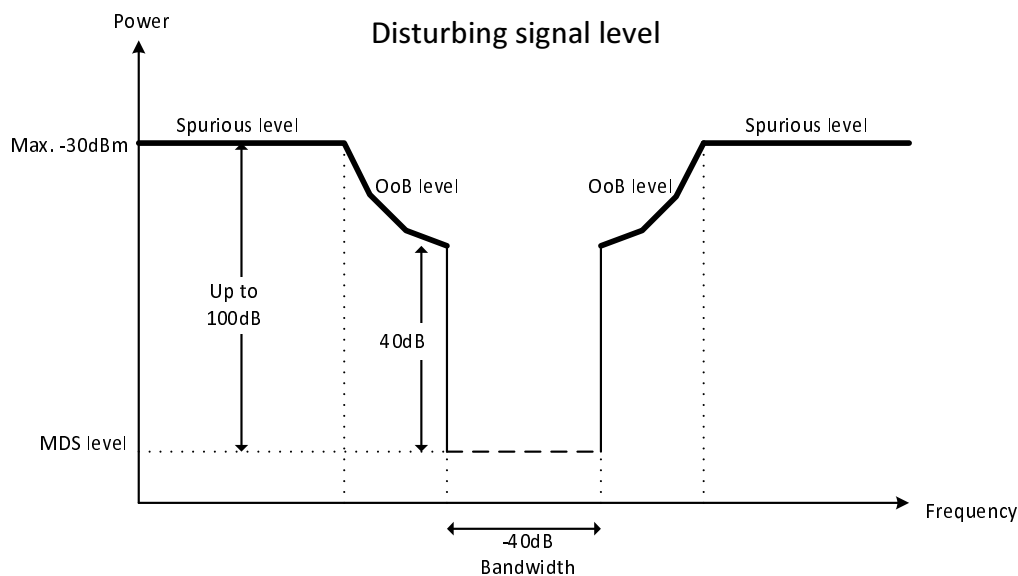

Figure 6: Receiver selectivity mask

The disturbance signal shall be a sinusoidal pulsed signal with pulse duration of 100 ns and a pulse repetition frequency of 1 kHz. The receiver selectivity curve shall then be verified at a practical number of measurement points (at least 8).

The measurement points shall be distributed over the OoB frequency spans outside the borders of B_{-40} and reaching the required spurious level both upwards and downwards in frequency. At each measurement point the disturbance signal level shall be MDS level plus the Out-of-Band level of the emission mask. This is illustrated in figure 6.

The radar video shall not show any "targets" at any of the measurement points. The radar transceiver is setup in normal operating mode during the test.

5.5.6.2 Receiver spurious response rejection

These measurements shall be performed under normal test conditions.

The frequency band in which the spurious response shall be checked is the part of the transmission band of the waveguide which is outside the Out-of-Band frequency range.

A test signal with the following characteristics shall be applied:

Sinusoidal pulsed signal with a pulse duration of 100 ns and a pulse repetition frequency of 1 kHz, no modulation, signal amplitude MDS + spurious level of emission mask.

The radar transceiver is setup in normal operating mode during the test.

In the test setup a WR112/R84 Waveguide taper section shall be connected to the regular WR90/R100 Waveguide.

NOTE: In this way the measurement setup is able to cover the cut-off frequency, otherwise the measurement setup will itself be "blind" near the cut-off frequency. With the taper section the cut-off is lowered to 6,56 GHz.

Due to the spurious signals, the radar video shall not show any "targets" at any of the measurement points.

Annex A (normative): HS Requirements and conformance Test specifications Table (HS-RTT)

The HS Requirements and conformance Test specifications Table (HS-RTT) in table A.1 serves a number of purposes, as follows:

- it provides a statement of all the technical requirements in words and by cross reference to (a) specific clause(s) in the present document or to (a) specific clause(s) in (a) specific referenced document(s);
- it provides a statement of all the test procedures corresponding to those technical requirements by cross reference to (a) specific clause(s) in the present document or to (a) specific clause(s) in (a) specific referenced document(s);
- it qualifies each requirement to be either:
 - Unconditional: meaning that the technical requirement applies in all circumstances; or
 - Conditional: meaning that the technical requirement is dependent on the manufacturer having chosen to support optional functionality defined within the schedule.
- in the case of Conditional requirements, it associates the technical requirement with the particular optional service or functionality;
- it qualifies each test procedure to be either:
 - Essential: meaning that it is included with the Essential Radio Test Suite and therefore the technical requirement shall be demonstrated to be met in accordance with the referenced procedures;
 - Other: meaning that the test procedure is illustrative but other means of demonstrating compliance with the technical requirement are permitted.

Table A.1: HS Requirements and conformance Test specifications Table (HS-RTT)

Harmonized Standard EN 303 135						
The following requirements and test specifications are relevant to the presumption of conformity under the article 3.2 of the R&TTE Directive [i.1]						
Technical Requirement Reference			Technical Requirement Conditionality		Test Specification	
No	Description	Reference: Clause No	U/C	Condition	E/O	Reference: Clause No
1	Operating frequency	4.2.1	U		E	5.5.1
2	Transmitter pulse power	4.2.2	U		E	5.5.2
3	Radiated Out-of-Band emissions	4.2.3	U		E	5.5.3
4	Radiated spurious emissions	4.2.4	U		E	5.5.4
5	Receiver Noise Figure	4.3.1	U		E	5.5.5
6	Receiver Selectivity	4.3.2	U		E	5.5.6

Key to columns:

Technical Requirement:

No A unique identifier for one row of the table which may be used to identify a technical requirement or its test specification.

Description A textual reference to the requirement.

Clause Number Identification of clause(s) defining the requirement in the present document unless another document is referenced explicitly.

Technical Requirement Conditionality:

U/C Indicates whether the technical requirement is to be *unconditionally* applicable (U) or is *conditional* upon the manufacturers claimed functionality of the equipment (C).

Condition Explains the conditions when the technical requirement shall or shall not be applicable for a technical requirement which is classified "conditional".

Test Specification:

E/O Indicates whether the test specification forms part of the Essential Radio Test Suite (E) or whether it is one of the Other Test Suite (O).

NOTE: All tests whether "E" or "O" are relevant to the technical requirements. Rows designated "E" collectively make up the Essential Radio Test Suite; those designated "O" make up the Other Test Suite; for those designated "X" there is no test specified corresponding to the technical requirement. The completion of all tests classified "E" as specified with satisfactory outcomes is a necessary condition for a presumption of conformity. Compliance with technical requirements associated with tests classified "O" or "X" is a necessary condition for presumption of conformity, although conformance with the technical requirement may be claimed by an equivalent test or by manufacturer's assertion supported by appropriate entries in the technical construction file.

Clause Number Identification of clause(s) defining the test specification in the present document unless another document is referenced explicitly. Where no test is specified (that is, where the previous field is "X") this field remains blank.

Annex B (normative): Transmission power and unwanted emissions of radar systems with indirect methods

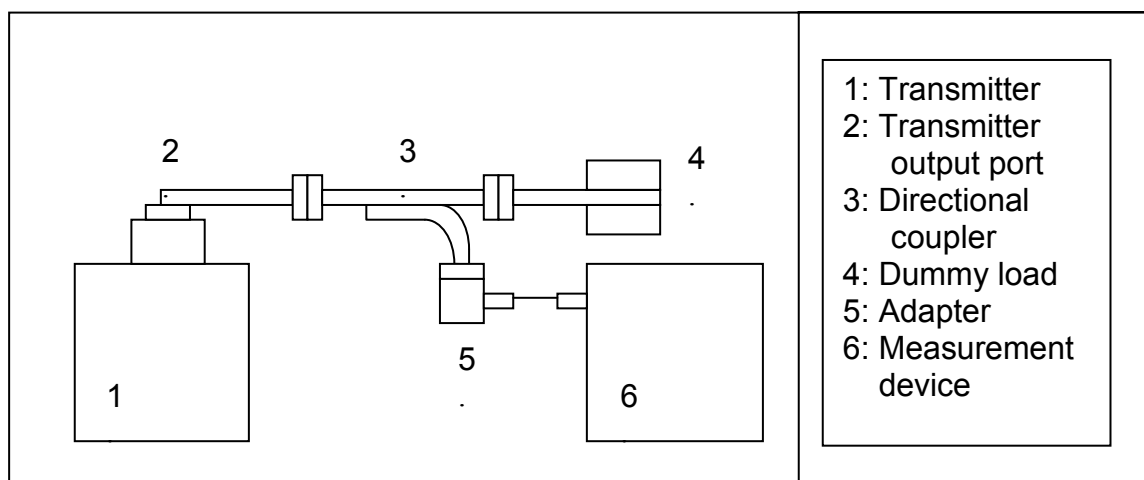

Figure B.1: Indirect method for radio frequency measurements with dismantled antenna

In order to measure the operation frequency, the transmit power as well as the Out-of-Band and spurious emission measurements, the method shown in figure B.1 shall be applied.

Annex C (informative): Bibliography

Recommendation ITU-R SM.328-11: "Spectra and bandwidth of emissions".

Recommendation ITU-R SM.329-10: "Unwanted emissions in the spurious domain".

ETSI TR 102 273 (2001): "Electromagnetic compatibility and Radio spectrum Matters (ERM); Improvement on Radiated Methods of Measurement (using test site) and evaluation of the corresponding measurement uncertainties".

ANSI C63.5 (2006): "American National Standard for Calibration of Antennas Used for Radiated Emission Measurements in Electro Magnetic Interference".

Directive 2004/108/EC of the European Parliament and of the Council of 15 December 2004 on the approximation of the laws of the Member States relating to electromagnetic compatibility and repealing Directive 89/336/EEC (EMC Directive).

Directive 2006/95/EC of the European Parliament and of the Council of 12 December 2006 on the harmonisation of the laws of Member States relating to electrical equipment designed for use within certain voltage limits (LV Directive).

History

Document history			
V0.0.7	January 2014	EN Approval Procedure	AP 20140510: 2014-01-10 to 2014-05-12