



**Electromagnetic compatibility and
Radio spectrum Matters (ERM);
Maritime low power personal locating beacons employing AIS
Part 1: Technical characteristics and methods of measurement**

ReferenceDEN/ERM-TG26-100-1

Keywordsmaritime, radio, SAR, testing

ETSI

650 Route des Lucioles
F-06921 Sophia Antipolis Cedex - FRANCE

Tel.: +33 4 92 94 42 00 Fax: +33 4 93 65 47 16

Siret N° 348 623 562 00017 - NAF 742 C
Association à but non lucratif enregistrée à la
Sous-Préfecture de Grasse (06) N° 7803/88

Important notice

Individual copies of the present document can be downloaded from:

<http://www.etsi.org>

The present document may be made available in more than one electronic version or in print. In any case of existing or perceived difference in contents between such versions, the reference version is the Portable Document Format (PDF). In case of dispute, the reference shall be the printing on ETSI printers of the PDF version kept on a specific network drive within ETSI Secretariat.

Users of the present document should be aware that the document may be subject to revision or change of status. Information on the current status of this and other ETSI documents is available at

<http://portal.etsi.org/tb/status/status.asp>

If you find errors in the present document, please send your comment to one of the following services:

http://portal.etsi.org/chaicor/ETSI_support.asp

Copyright Notification

No part may be reproduced except as authorized by written permission.
The copyright and the foregoing restriction extend to reproduction in all media.

© European Telecommunications Standards Institute 2013.
All rights reserved.

DECT™, **PLUGTESTS™**, **UMTS™** and the ETSI logo are Trade Marks of ETSI registered for the benefit of its Members.
3GPP™ and **LTE™** are Trade Marks of ETSI registered for the benefit of its Members and of the 3GPP Organizational Partners.
GSM® and the GSM logo are Trade Marks registered and owned by the GSM Association.

Contents

Intellectual Property Rights	7
Foreword.....	7
Introduction	7
1 Scope	8
2 References	8
2.1 Normative references	8
2.2 Informative references.....	9
3 Definitions, symbols and abbreviations	9
3.1 Definitions.....	9
3.2 Symbols.....	9
3.3 Abbreviations	9
4 General requirements	10
4.1 Construction	10
4.1.1 Categories of equipment	10
4.2 Controls	11
4.3 Indicators.....	11
4.4 Identifier (user ID).....	11
4.5 Labelling.....	11
4.6 Instructions	12
4.7 Power source	12
4.7.1 Battery requirements	12
4.7.2 Safety precautions.....	12
5 Technical requirements	13
5.1 General	13
5.2 AIS transmission characteristics.....	13
5.2.1 AIS messages.....	13
5.2.1.1 Active mode	13
5.2.1.2 Training mode.....	13
5.2.1.3 Test mode.....	14
5.2.2 Synchronization	14
5.2.2.1 Active and Training modes	14
5.2.2.2 Test mode.....	14
5.2.3 GNSS position source.....	14
5.2.3.1 UTC Time	15
5.2.3.2 Almanac Storage	15
5.2.4 Required settings	15
5.2.5 Minimum transmitter performance characteristics	16
5.2.6 VHF Data Link (VDL) Access	16
5.2.6.1 Active and Training modes	16
5.2.6.2 Test mode.....	17
5.3 Locating beacon power source	17
5.3.1 Battery requirements.....	17
6 General conditions of measurement	17
6.1 Conformity testing.....	17
6.2 Test Frequencies.....	17
6.3 Identifier (user ID).....	17
6.4 Artificial Antenna.....	17
6.5 Test signals	18
6.5.1 Standard test signal number 1	18
6.5.2 Standard test signal number 2	18
6.5.3 Standard test signal number 3	18
6.5.4 Reference timing signal	18

6.6	Measurement uncertainty and interpretation of the measured results	18
6.6.1	Measurement uncertainty.....	18
6.6.2	Interpretation of the measurement results	18
6.7	Test conditions power sources and ambient temperatures.....	19
6.7.1	Normal and extreme test conditions.....	19
6.7.2	Test power source	19
6.8	Normal test conditions.....	19
6.8.1	Normal temperature and humidity	19
6.8.2	Normal test voltage	19
6.9	Extreme test conditions	19
6.9.1	Extreme temperatures	19
6.9.1.1	Procedure for tests at extreme temperatures.....	19
6.9.2	Extreme test voltages	20
6.9.2.1	Upper extreme test voltage.....	20
6.9.2.2	Lower extreme test voltage	20
7	Environmental tests	20
7.1	Introduction	20
7.2	Procedure.....	20
7.3	Performance check	20
7.4	Drop test	20
7.4.1	Definition.....	20
7.4.2	Test conditions.....	20
7.4.3	Method of measurement	21
7.4.4	Requirements	21
7.5	Temperature tests	21
7.5.1	Definition.....	21
7.5.2	Dry heat test.....	21
7.5.2.1	Method of measurement.....	21
7.5.2.2	Requirement	21
7.5.3	Damp heat test	22
7.5.3.1	Method of measurement.....	22
7.5.3.2	Requirement	22
7.5.4	Low temperature test	22
7.5.4.1	Method of measurement.....	22
7.5.4.2	Requirement	22
7.6	Vibration test.....	22
7.6.1	Definition.....	22
7.6.2	Method of measurement	22
7.6.3	Requirement.....	23
7.7	Corrosion test	23
7.7.1	Definition.....	23
7.7.2	Method of measurement	23
7.7.3	Requirements	24
7.8	Thermal shock test.....	24
7.8.1	Definition.....	24
7.8.2	Method of measurement	24
7.8.3	Requirements	24
7.9	Buoyancy test	24
7.9.1	Definition.....	24
7.9.2	Method of measurement	24
7.9.3	Requirements	24
7.10	Compass safe distance test	25
7.10.1	Definition.....	25
7.10.2	Method of measurement	25
7.10.3	Requirements	25
7.11	Solar radiation test.....	26
7.11.1	Definition.....	26
7.11.2	Method of measurement	26
7.11.3	Requirements	26
7.12	Oil resistance test.....	26
7.12.1	Definition.....	26

7.12.2	Method of measurement	26
7.12.3	Requirements	27
7.13	Protection of the transmitter	27
7.13.1	Definition.....	27
7.13.2	Method of measurement	27
7.13.3	Requirement.....	27
8	Tests on the AIS transmitter	27
8.1	Frequency error	27
8.1.1	Definition.....	27
8.1.2	Method of measurement	27
8.1.3	Limit	27
8.2	Conducted Power	27
8.2.1	Definition.....	28
8.2.2	Method of measurement under normal test conditions	28
8.2.3	Limit	28
8.3	Maximum Effective Radiated Power (ERP).....	28
8.3.1	Definition.....	28
8.3.2	Method of measurement	28
8.3.3	Limits.....	29
8.4	Transmitter spectrum mask	29
8.4.1	Definition.....	29
8.4.2	Method of measurement	29
8.4.3	Limit	30
8.5	Transmitter transient behaviour (output power).....	30
8.5.1	Definition.....	30
8.5.2	Method of measurement	31
8.5.3	Limit	32
8.6	Transmitter Transient Behaviour (frequency deviation)	32
8.6.1	Definition.....	32
8.6.2	Method of measurement	32
8.6.3	Limit	33
8.7	Synchronization accuracy.....	33
8.7.1	Definition.....	33
8.7.2	Method of measurement	33
8.7.3	Limit	34
8.8	Spurious emissions	35
8.8.1	Definition.....	35
8.8.2	Method of measurement	35
8.8.3	Limit	35
9	VDL Link layer tests	35
9.1	Active mode tests	35
9.1.1	Method of measurement	35
9.1.2	Initialization period - Required results.....	36
9.1.3	Message content of Message 1 - Required results	36
9.1.4	Message content of Message 14 - Required results	36
9.1.5	Transmission schedule for Message 1 - Required results	36
9.1.6	Communication state of Message 1 - Required results	37
9.1.7	Transmission schedule of Message 14 - Required results.....	37
9.1.8	Transmission with lost GNSS - Required results.....	37
9.2	Test mode tests with GNSS data available.....	38
9.2.1	Method of measurement	38
9.2.2	Required results	38
9.3	Test mode tests without GNSS data available.....	38
9.3.1	Method of measurement	38
9.3.2	Required results	38
Annex A (normative):	Radiated measurements	39
A.1	Test sites and general arrangements for measurements involving the use of radiated fields	39
A.1.1	Anechoic chamber	39
A.1.2	Anechoic chamber with a ground plane	40

A.1.3	OATS	41
A.1.4	Test antenna.....	42
A.1.5	Substitution antenna	42
A.1.6	Measuring antenna	43
A.2	Guidance on the use of radiation test sites	43
A.2.1	Verification of the test site	43
A.2.2	Preparation of the EUT.....	43
A.2.3	Power supplies to the EUT	43
A.2.4	Volume control setting for analogue speech tests	43
A.2.5	Range length.....	44
A.2.6	Site preparation	44
A.3	Coupling of signals.....	45
A.3.1	General	45
A.3.2	Data signals	45
A.3.3	Speech and analogue signals	45
A.3.3.1	Acoustic coupler description.....	45
A.3.3.2	Calibration	46
A.4	Standard position.....	46
Annex B (normative):	Locating beacon message bursts.....	47
B.1	Active mode	47
B.2	Training mode	48
B.3	Test mode	49
B.4	Default message field values	49
History		50

Intellectual Property Rights

IPRs essential or potentially essential to the present document may have been declared to ETSI. The information pertaining to these essential IPRs, if any, is publicly available for **ETSI members and non-members**, and can be found in ETSI SR 000 314: "*Intellectual Property Rights (IPRs); Essential, or potentially Essential, IPRs notified to ETSI in respect of ETSI standards*", which is available from the ETSI Secretariat. Latest updates are available on the ETSI Web server (<http://ipr.etsi.org>).

Pursuant to the ETSI IPR Policy, no investigation, including IPR searches, has been carried out by ETSI. No guarantee can be given as to the existence of other IPRs not referenced in ETSI SR 000 314 (or the updates on the ETSI Web server) which are, or may be, or may become, essential to the present document.

Foreword

This draft European Standard (EN) has been produced by ETSI Technical Committee Electromagnetic compatibility and Radio spectrum Matters (ERM), and is now submitted for the combined Public Enquiry and Vote phase of the ETSI standards EN Approval Procedure.

The present document is part 1 of a multi-part deliverable covering the Electromagnetic compatibility and Radio spectrum Matters (ERM); Maritime low power personal locating beacons employing AIS, as identified below:

- Part 1: "Technical characteristics and methods of measurement";**
- Part 2: "Harmonized EN covering the essential requirements of article 3.2 of the R&TTE Directive";
- Part 3: "Harmonized EN covering the essential requirements of article 3.3 (e) of the R&TTE Directive".

The present document lays down the minimum requirements for "Maritime low power personal locating beacons employing AIS", and incorporates the relevant provisions of the International Telecommunication Union (ITU) radio regulations.

Proposed national transposition dates	
Date of latest announcement of this EN (doa):	3 months after ETSI publication
Date of latest publication of new National Standard or endorsement of this EN (dop/e):	6 months after doa
Date of withdrawal of any conflicting National Standard (dow):	18 months after doa

Introduction

The present document has been produced by ETSI in response to a mandate from the European Commission issued under Council Directive 98/34/EC [i.4] laying down a procedure for the provision of information in the field of technical standards and regulations.

1 Scope

The present document lays down the minimum requirements for low power maritime personal locating beacons employing AIS and an integrated GNSS receiver to provide the locating function. The present document incorporates the relevant provisions of the International Telecommunication Union (ITU) radio regulations included in Recommendation ITU-R M.1371-4 [1]

For this application, both the radiated power and the length of time of operation are limited to enable the equipment to be sufficiently small and light to be worn comfortably at all times and to limit the operating range to a local area.

2 References

References are either specific (identified by date of publication and/or edition number or version number) or non-specific. For specific references, only the cited version applies. For non-specific references, the latest version of the reference document (including any amendments) applies.

Referenced documents which are not found to be publicly available in the expected location might be found at <http://docbox.etsi.org/Reference>.

NOTE: While any hyperlinks included in this clause were valid at the time of publication, ETSI cannot guarantee their long term validity.

2.1 Normative references

The following referenced documents are necessary for the application of the present document.

- [1] Recommendation ITU-R M.1371-4 (04/2010): "Technical characteristics for an automatic identification system using time-division multiple access in the VHF maritime mobile band".
- [2] ETSI TR 100 028 (all parts) (V1.4.1): "Electromagnetic compatibility and Radio spectrum Matters (ERM); Uncertainties in the measurement of mobile radio equipment characteristics".
- [3] ETSI TR 102 273-7 (2001): "Electromagnetic compatibility and Radio spectrum Matters (ERM); Improvement on Radiated Methods of Measurement (using test site) and evaluation of the corresponding measurement uncertainties; Part 7: Artificial human beings".
- [4] CENELEC EN 61108-1 (2003): "Maritime navigation and radiocommunication equipment and systems - Global navigation satellite systems (GNSS) - Part 1: Global positioning system (GPS) - Receiver equipment - Performance standards, methods of testing and required test results".
- [5] CENELEC EN 61108-2 (1998): "Maritime navigation and radiocommunication equipment and systems - Global navigation satellite systems (GNSS) - Part 2: Global navigation satellite system (GLONASS) - Receiver equipment - Performance standards, methods of testing and required test results".
- [6] CENELEC EN 61108-3 (2010): "Maritime navigation and radiocommunication equipment and systems - Global navigation satellite systems (GNSS) - Part 3: Galileo receiver equipment - Receiver equipment - Performance standards, methods of testing and required test results".
- [7] Recommendation ITU-T O.153 (10/92): "Basic parameters for the measurement of error performance at bit rates below the primary rate".

2.2 Informative references

The following referenced documents are not necessary for the application of the present document but they assist the user with regard to a particular subject area.

- [i.1] ETSI TR 102 273 (Parts 2, 3 and 4) (V1.2.1): "Electromagnetic compatibility and Radio spectrum Matters (ERM); Improvement on Radiated Methods of Measurement (using test site) and evaluation of the corresponding measurement uncertainties".
- [i.2] ANSI C63.5-2006: "American National Standard for Calibration of Antennas Used for Radiated Emission Measurements in Electro Magnetic Interference".
- [i.3] IEC 60489-3 (edition 2.0) (Appendix F of Amendment 1): "Methods of measurement for radio equipment used in the mobile services. Part 3: Receivers for A3E or F3E emissions".
- [i.4] Directive 98/34/EC of the European Parliament and of the Council of 22 June 1998 laying down a procedure for the provision of information in the field of technical standards and regulations.

3 Definitions, symbols and abbreviations

3.1 Definitions

For the purposes of the present document the following terms and definitions apply:

active mode: activated mode, transmitting in an emergency situation

test mode: self testing mode, not involved in a genuine emergency

training mode: activated mode for training purposes only

UTC lock: GNSS has precisely locked to UTC time so that it can determine SOTDMA slot timing correctly, including leap second corrections

3.2 Symbols

For the purposes of the present document, the following symbols apply:

ε	permittivity
σ	Conductivity
λ	wavelength
cSt	centi-Stokes
dB	decibel
div	division
S	Siemens
μT	microtesla

3.3 Abbreviations

For the purposes of the present document, the following abbreviations apply:

AIS	Automatic Identification System
ASTM	American Society for Testing and Materials
COG	Course Over Ground
CRC	Cyclic Redundancy Check
CSP	Channel Spacing
CW	Continuous Wave
ERP	Effective Radiated Power
EUT	Equipment Under Test

GLONASS	Globalnaya Navigatsionnaya Sputnikovaya Sistema
GMSK	Gaussian Minimum Shift Keying
GNSS	Global Navigation Satellite System
GPS	Global Positioning System
GTRF	Galileo Terrestrial Reference Frame System
ITRF	International Terrestrial Reference Frame
MOB	Man Over-Board
NRZI	Non Return to Zero, Inverted
OATS	Open Area Test Site
PPS	Pulses Per Second
RAIM	Receiver Autonomous Integrity Monitoring
RF	Radio Frequency
SINAD	(Signal+Noise+Distortion) to (Noise + Distortion)
SOG	Speed Over Ground
SOTDMA	Self-Organised Time Division Multiple Access
TDMA	Time Division Multiple Access
UTC	Coordinated Universal Time
VDL	AIS VHF data link
VHF	Very High Frequency
VSWR	Voltage Standing Wave Ratio

4 General requirements

4.1 Construction

The manufacturer shall declare that compliance to the requirements of this clause (clause 4) is achieved and shall provide relevant documentation.

In all respects, the mechanical and electrical design and the construction and finish of the equipment shall conform with good engineering practice.

The equipment shall be designed to minimize the risk of internal and external damage during use or stowage.

The exterior of the equipment shall have no sharp edges or projections that could easily damage inflatable rafts or injure personnel.

The general construction and method of operation shall provide a high degree of proof against inadvertent operation due to magnetic influences, handling, stowage and transit, whilst still providing a simple means of operation in an emergency.

The equipment shall be portable, lightweight, compact and be designed as one integral unit. The locating beacon shall derive its energy from a battery forming a part of the equipment and incorporate a permanently attached antenna which may be either fixed length or extendible.

The locating beacon may be fitted with a test facility by which the functioning of the transmitter and battery can be easily tested without the use of any external equipment.

The equipment shall be capable of being used by an unskilled person.

The locating beacon shall be watertight and buoyant.

A substantial part of the equipment shall be of highly visible yellow or orange colour to assist visual location.

The equipment shall not be unduly affected by sea water or oil and shall be resistant to deterioration by prolonged exposure to sunlight.

4.1.1 Categories of equipment

Two categories are defined:

- Category 1 radio beacons shall have sufficient positive buoyancy to float in fresh water.

- Category 2 radio beacons intended to be incorporated into or attached to a buoyancy device are not required to float.

The user manual or instructions for Category 2 beacons shall include necessary information to allow the user to fit or attach the beacon.

4.2 Controls

The equipment shall be initially activated by the use of two simple, but independent mechanical actions, neither of which on its own shall activate the equipment. The second mechanical action may be replaced by an immersion sensor.

It shall only be possible to activate the equipment after a seal or other mechanical restraint has been removed from the first mechanical action. After activation it shall be simple to de-activate the equipment and the means to deactivate the equipment shall be clearly marked.

The switch that operates any test facility (clause 4.1) shall be so designed that it returns automatically to the off-position when released.

4.3 Indicators

The equipment shall be provided with a visual and/or audible indication that signals are being emitted. The indicator shall be sufficiently bright to be seen in bright sunlight. Except when operating in test mode the indicator shall not be green in colour.

The indicator shall clearly distinguish the following states:

- (i) The locating beacon has been activated and is waiting for GNSS data.
- (ii) The locating beacon has GNSS data and is transmitting in active mode.
- (iii) The locating beacon has GNSS data and is transmitting in training mode.
- (iv) The locating beacon is undergoing test and is transmitting in test mode.
- (v) The locating beacon has completed a test or has been de-activated.

4.4 Identifier (user ID)

The locating beacon shall have an identifier to distinguish it from other AIS devices.

The User ID for a personal search and rescue locating beacon is 972xyyyyy, where xx = manufacturer ID 01 to 99; yyyy = the sequence number 0000 to 9999. Manufacturers IDs are issued by CIRM (www.cirm.org).

After being programmed by the manufacturer, it shall not be possible for the user to change the identifier of the locating beacon.

The user ID shall be held in non-volatile memory.

4.5 Labelling

The equipment shall be provided with a label, or labels, permanently affixed to the exterior of the equipment, containing the following information:

- user ID of the equipment (see clause 4.4) and manufacturer serial number;
- type designation of the equipment with prefix AIS-MOB;
- adequate instructions to enable the equipment to be activated and de-activated;
- the type of battery as specified by the manufacturer of the locating beacon;

- the date on which the battery will need to be replaced. Simple means shall be provided for changing this date when the battery is replaced. The battery replacement date marked on the locating beacon should be the date of battery installation in the locating beacon plus no more than 50 % of the rated life of the battery, provided that the battery cells are no older than 25 % of the rated life of the battery;
- a warning to the effect that the locating beacon should not be operated except in an emergency;
- a warning to not block the GNSS antenna;
- the compass safe distance as measured in clause 7.10.

4.6 Instructions

Necessary operating instructions shall be provided with the equipment. These should include the following warnings:

- "WARNING - An AIS-MOB Man overboard device is only intended for short range signalling to an AIS receiver installed onboard your own vessel. It will not directly alert the emergency services."
- "WARNING - This equipment is not intended for routine tracking of persons or property. This includes tracking of divers."
- "WARNING - If self-test is performed more frequently than once a month, then battery life may be reduced."

4.7 Power source

4.7.1 Battery requirements

The type of battery and designation specified by the manufacturer for use in the equipment shall be clearly and indelibly marked on the equipment.

The manufacturer should establish a useful life and an expiry date for primary (non-rechargeable) batteries. The useful life is the period of time after the date of battery manufacture that the battery will continue to meet the input power requirements of the locating beacon, over the entire specified operating temperature range. The following losses shall be included (at a temperature of $+20\text{ °C} \pm 5\text{ °C}$):

- a) self-testing monthly with GNSS data available;
- b) self-discharge of the battery;
- c) stand-by loads.

The expiry date of the battery shall be the battery manufacturing date plus no more than half the useful life of the battery. The battery shall have a minimum useful life of at least two years. The battery shall be clearly and durably marked with its expiry date.

4.7.2 Safety precautions

Provisions shall be made for protecting the equipment from damage due to the accidental reversal of polarity of the battery.

5 Technical requirements

5.1 General

When activated the locating beacon shall be capable of transmitting messages that indicate the position of a person in the water. The transmitted messages shall be compatible with existing AIS installations. The transmitted messages shall be recognized and displayed by AIS receivers in the reception range of the transmitter, and clearly distinguish the transmitter as a personal Man Over-Board (MOB) locating beacon. AIS TDMA Synchronization shall be UTC direct; the locating beacon does not require an AIS receiver.

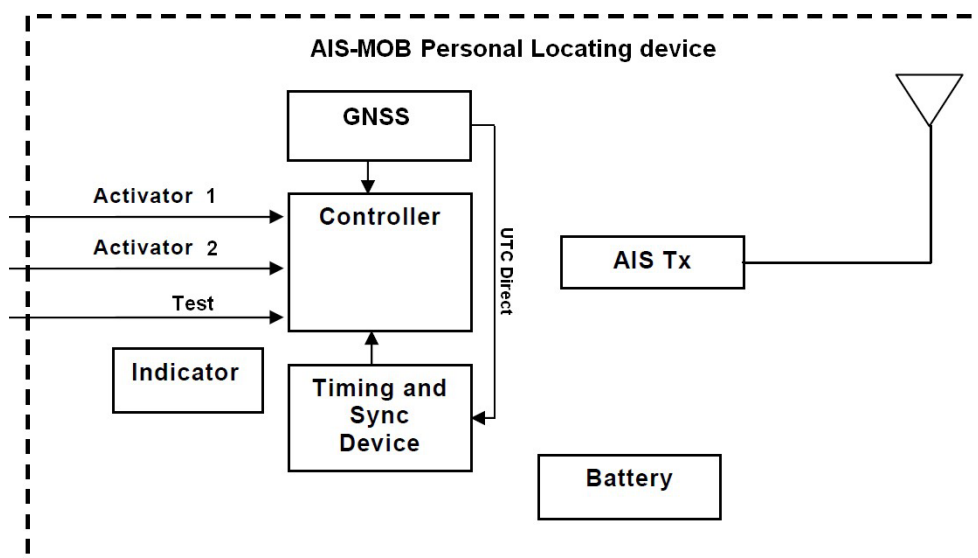

Figure 1: Functional block diagram of personal locating beacon

5.2 AIS transmission characteristics

The AIS Tx transmits using modified SOTDMA on two channels AIS1 and AIS2. The GNSS receiver, e.g. a GPS receiver, determines the current position of the locating beacon and facilitates TDMA synchronization in the UTC direct mode.

The locating beacon shall shutdown automatically if, under a fault condition, the transmitter remains permanently keyed for more than 2 seconds. This shutdown shall be independent of the operating software.

5.2.1 AIS messages

The locating beacon shall broadcast Message 1 and Message 14, as defined in Recommendation ITU-R M.1371-4 [1]. The content of the messages differs for active transmissions (active and training modes) and test transmissions (test mode). The combination of these messages in burst sequences is detailed in annex B.

5.2.1.1 Active mode

For Message 1 the Navigational status shall be set to "14". For message 14 the safety related text shall be set to "MOB ACTIVE" (see clause B.1 for details).

5.2.1.2 Training mode

For Message 1 the Navigational status shall be set to "15". For message 14 the safety related text shall be set to "MOB TEST" (see clause B.2 for details).

5.2.1.3 Test mode

For Message 1 the Navigational status shall be set to "15". For message 14 the safety related text shall be set to "MOB TEST" (see clause B.3 for details).

5.2.2 Synchronization

In UTC direct mode the locating beacon determines slot timing using the UTC timing signal from the GNSS.

The TDMA timing error shall be less than ± 312 μ S.

The position of the locating beacon shall be determined at least every minute once a GNSS position fix has been obtained.

5.2.2.1 Active and Training modes

The locating beacon shall start transmitting as soon as a position fix, SOG, COG and UTC time are available. The beacon shall only transmit if UTC lock is established so that SOTDMA is properly synchronized. If after one minute a position fix has not been established but UTC lock is established then the locating beacon shall use default settings, where appropriate (see clause B.4 for details).

The locating beacon shall begin synchronized transmission with the correct GNSS position within 5 minutes under normal operating conditions. To achieve this the equipment shall apply the stored leap second prediction. Where the prediction is invalid (time expired), but UTC is available then transmission shall be attempted using available UTC as a last resort.

The locating beacon shall continue transmission even if the position and UTC time synchronization from the positioning system is subsequently lost or fails. The locating beacon shall maintain timing internally if UTC lock is lost. If a position fix is lost, the locating beacon shall continue to transmit with the last known good position (see clause B.4).

5.2.2.2 Test mode

A single test message burst (see clause B.3) shall be transmitted as soon as a position fix, SOG, COG and time are available. The beacon shall transmit when UTC is available so that SOTDMA is properly synchronized even if the almanac is invalid. If UTC is not available after five minutes the beacon shall abandon the test mode without transmitting. If the almanac is invalid the test shall be extended until a valid almanac is downloaded although no further transmission shall be attempted. If the locating beacon does not acquire position, SOG, COG within 5 minutes, but does have UTC available it shall transmit a test message using default settings, where appropriate (see clause B.4 for details).

Activation of the test facility shall reset automatically after transmission of the burst.

5.2.3 GNSS position source

The GNSS compliant receiver shall meet the following requirements of EN 61108 series (GPS [4], GLONASS [5] or Galileo [6]): position accuracy, acquisition, re-acquisition, receiver sensitivity, RF dynamic range, position update, effects of specific interference signals but with a minimum update rate of once per minute, provide a resolution of one ten thousandth of a minute of arc and uses the WGS-84 datum.

NOTE: Galileo uses Galileo Terrestrial Reference Frame System (GTRF) datum which is a realization of the International Terrestrial Reference Frame (ITRF) system and differs from WGS-84 by less than 5 cm worldwide. GLONASS uses the Parametry Zemli 1990 (PZ-90) datum. As of September 17, 2007 the PZ-90 datum has been updated to differ from WGS-84 by less than 40 cm worldwide.

The manufacturer shall provide evidence that an internal GNSS device cold start is forced at every AIS-MOB activation (cold start refers to the absence of time dependent or position dependent data in memory, which might affect the acquisition of the GNSS position).

5.2.3.1 UTC Time

All AIS equipment uses UTC time for synchronizing transmissions. The version of UTC time transmitted by both GPS and Galileo, is not perturbed by leap seconds so that GPS time as of January 2013 is ahead of UTC by 16 seconds. The version of UTC time transmitted by GLONASS does apply leap seconds and remains synchronized to UTC albeit offset by 3 hours. Both GPS and Galileo transmit the timing offset that must be applied in the GNSS receiver when computing UTC. AIS SOTDMA relies on the correct and timely computation of UTC to determine slot timings accurately. Since the AIS slot structure repeats every two seconds, the incorrect application of a leap second when determining UTC will result in AIS transmissions beginning in the middle of a time slot rather than at the beginning of the time slot. Care must be taken when designing multi-system GNSS receivers that UTC is correctly determined across satellite systems.

Since the equipment is required to do a GNSS cold start and to transmit its first valid position within 5 minutes of activation, for GPS and Galileo GNSS receivers the equipment shall maintain a stored copy of the Almanac.

5.2.3.2 Almanac Storage

Manufacturers shall provide a mechanism whereby the stored copy of the Almanac can be kept up to date. The GNSS cold start shall not make use of any stored information other than a valid leap second prediction.

It shall be possible to update the almanac stored in the equipment either off-air (from the satellite signals), or via another interface supplied by the manufacturer. The means for updating the stored almanac shall be comprehensively described in the user instructions supplied with the equipment.

5.2.4 Required settings

The locating beacon shall operate on dual channels, AIS1 and AIS2, in the VHF Maritime Mobile Service band. Tables 1, 2 and 3 are derived from Recommendation ITU-R M.1371-4 [1] and give the parameters required for an AIS locating beacon.

Table 1: Required parameter settings

Symbol	Parameter name	Setting
PH.AIS1	Channel 1 (default channel 1)	161,975 MHz
PH.AIS2	Channel 2 (default channel 2)	162,025 MHz
PH.BR	Bit rate	9 600 bps
PH.TS	Training sequence	24 bits
PH.TST	Transmitter settling time (Transmit power within 20 % of final value. Frequency stable to within $\pm 1,0$ kHz of final value). Tested at manufacturers declared transmit power.	$\leq 1,0$ ms
	Ramp down time	≤ 832 μ s
	Transmission duration	$\leq 26,6$ ms
	Transmitter output power	600 mW ERP
NOTE:	The "Transmitter output power" level is subject to review and administrative coordination.	

Table 2: Required settings of physical layer constants

Symbol	Parameter name	Value
PH.DE	Data encoding	NRZI
PH.FEC	Forward error correction	Not used
PH.IL	Interleaving	Not used
PH.BS	Bit scrambling	Not used
PH.MOD	Modulation	Bandwidth adapted GMSK

Table 3: Modulation parameters of the physical layer

Symbol	Name	Value
PH.TXBT	Transmit BT-product	0,4
PH.MI	Modulation index	0,5

5.2.5 Minimum transmitter performance characteristics

The technical characteristics as specified in table 4 shall apply to the transmitter.

Table 4: Minimum required transmitter characteristics

Transmitter parameters	Requirements
Carrier power	nominal radiated power in the range of 25 mW to 600 mW ERP
Carrier frequency error	± 500 Hz (normal), $\pm 1\,000$ Hz (extreme)
Slotted modulation mask	-20 dBc $\Delta f > \pm 10$ kHz -40 dBc ± 25 kHz $< \Delta f < \pm 62,5$ kHz see figure 4 in clause 8.4
Transmitter test sequence and modulation Accuracy	$< 3\,400$ Hz for Bit 0, 1 (normal and extreme) $2\,400$ Hz ± 480 Hz for Bit 2, 3 (normal and extreme) $2\,400$ Hz ± 240 Hz for Bit 4 ... 31 (normal, $2\,400 + 480$ Hz extreme) For Bits Bit 32 ... 199 $1\,740 \pm 175$ Hz (normal, $1\,740 + 350$ Hz extreme) for a bit pattern of 0101 $2\,400$ Hz ± 240 Hz (normal, $2\,400 + 350$ Hz extreme) for a bit pattern of 00001111
Transmitter output power versus time	Power within mask shown in figure 5 and timings given in table 8 in clause 8.5.
Spurious emissions	maximum 0,2 uW
NOTE: The "Carrier power" maximum level is subject to review and administrative coordination.	

5.2.6 VHF Data Link (VDL) Access

The locating beacon shall use modified SOTDMA for the transmission of message bursts (annex B).

The locating beacon shall determine its own schedule for transmission of its messages based on random selection of the first slot of the first burst. The other 7 slots within the first burst shall be fixed with reference to the first slot of the burst. The increment between transmission slots within a burst shall be 75 slots and the transmissions shall alternate between channels AIS1 and AIS2.

5.2.6.1 Active and Training modes

In active and training modes (see figure 2), the locating beacon shall set a slot-time-out = 7 in the Communication state of all Message 1 transmissions in the first burst, and thereafter the slot time-out shall be decreased according to the rules of SOTDMA [1]. Since the locating beacon does not have an AIS receiver, all slots shall be regarded as candidates in the selection process. When time out occurs, the offset to the next set of 8 bursts is randomly selected at 1 minute ± 6 s.

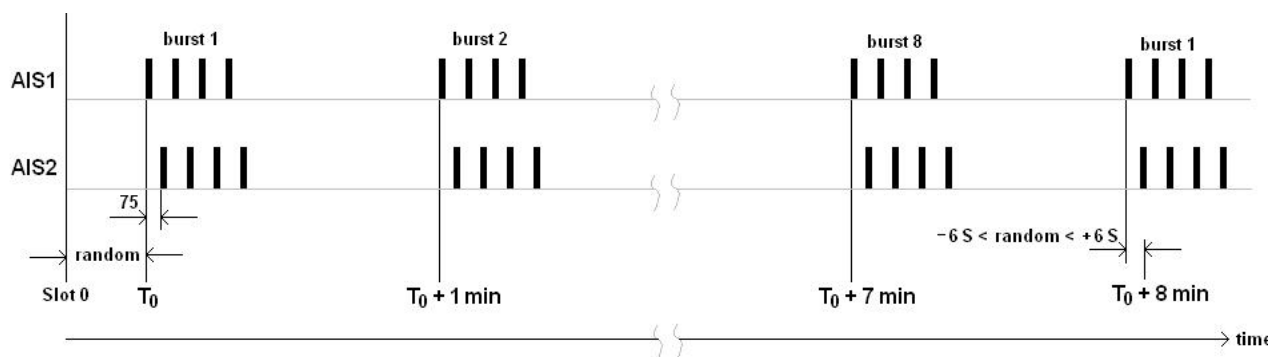

Figure 2: Burst transmissions in active and training modes

All slot-time-out values of the Communication state of all Message 1 transmissions within every burst shall be the same.

Two Message 14 shall be transmitted every 4th minute one on each channel, starting in the first minute (i.e. slot-time-out = 7 and 3), and shall be the 5th and 6th message in the burst (see clause B.1).

Message 14 shall be transmitted alternately on AIS1 and AIS2.

5.2.6.2 Test mode

In test mode the locating beacon shall set a slot-time-out = 0 and sub-message = 0 in the Communication state of all Message 1 transmissions in the first and only burst.

All slot time-out values of the Communication state of all Message 1 transmissions within every burst shall be the same.

Two Message 14 shall be transmitted one on each channel, and shall be the 1st and 8th message in the burst (see clause B.3).

5.3 Locating beacon power source

5.3.1 Battery requirements

The battery provided as a power source shall be a primary battery and have sufficient capacity to operate the equipment for an uninterrupted period of at least 6 hours, under all temperature conditions (clause 6.7), within the requirements of the present document.

6 General conditions of measurement

6.1 Conformity testing

For the purpose of conformity testing clauses 6.2 to 6.5 shall apply.

6.2 Test Frequencies

Where radiated measurements are not performed in an anechoic chamber alternative channels other than the default channels for AIS1 and AIS2 may be used during testing to avoid interference with live maritime systems. Where alternative channels are used the alternative channels used shall be of the same separation (50 KHz apart) and within $\pm 1\%$ of 162 MHz.

6.3 Identifier (user ID)

The manufacturer ID xx = 00 is reserved for conformance test purposes. The identifier used during testing to the present document shall be in the format 97200yyyy.

6.4 Artificial Antenna

Where applicable, tests shall be carried out using an artificial antenna which shall be a substantially non-reactive non-radiating load connected to the antenna connector. The Voltage Standing Wave Ratio (VSWR) at the 50 Ω connector or the provider's specified test fixture shall not be greater than 1,5:1 over the frequency range of the measurement.

In the case of integral antenna equipment, if the equipment does not have an internal permanent 50 Ω connector then it is permitted to supply a second sample of the equipment with a temporary 50 Ω antenna cable and connector fitted to facilitate testing.

6.5 Test signals

The manufacturer shall supply with the submitted samples a method for producing the following test transmission signals. In addition, for some tests, it shall be possible to operate the samples in a continuous unmodulated transmission (CW) mode.

NOTE: Transmitters may have limitations concerning their maximum continuous transmit time and/or their transmission duty cycle. It is intended that such limitations are respected during testing.

6.5.1 Standard test signal number 1

A series of reversals 010101... transmitted as all the bits within an AIS message frame, including header, start flag, end flag and CRC. NRZI is not applied to the reversals or CRC (Cyclic Redundancy Check), i.e. unaltered "On Air" data. The RF should be ramped up and down on either end of the AIS message frame.

6.5.2 Standard test signal number 2

A series of 00001111... repeated as the data within an AIS message frame, including header, start flag, end flag and CRC. NRZI is not applied to the data or CRC. The RF should be ramped up and down on either end of the AIS message frame.

6.5.3 Standard test signal number 3

A 511-bit pseudo random sequence as specified in Recommendation ITU-T O.153 [7] as the data within an AIS message frame with header, start flag, end flag and CRC. NRZI is not applied to the pseudo random sequence or CRC. The RF should be ramped up and down on either end of the AIS message frame.

6.5.4 Reference timing signal

For the timing tests in clauses 8.5, 8.6 and 8.7 the manufacturer shall supply a sample that produces an edge trigger timing signal corresponding to T_0 in figure 5 of clause 8.5.

6.6 Measurement uncertainty and interpretation of the measured results

6.6.1 Measurement uncertainty

Absolute measurement uncertainties (maximum values) are specified in table 5.

Table 5: Absolute measurement uncertainties: maximum values

Parameter	Maximum uncertainty
RF frequency	$\pm 1 \times 10^{-7}$
Radiated emission of transmitter	± 6 dB
Conducted RF power variations using a test fixture	$\pm 0,75$ dB
Transmitter attack time	± 20 %
Transmitter release time	± 20 %

6.6.2 Interpretation of the measurement results

The interpretation of the results recorded in a test report for the measurements described in the present document shall be as follows:

- the measured value related to the corresponding limit will be used to decide whether an equipment meets the requirements of the present document;

- the value of the measurement uncertainty for the measurement of each parameter shall be included in the test report;
- the recorded value of the measurement uncertainty shall be, for each measurement, equal to or lower than the figures in table 5.

For the test methods, according to the present document, the measurement uncertainty figures shall be calculated in accordance with TR 100 028 [2] and shall correspond to an expansion factor (coverage factor) $k = 1,96$ or $k = 2$ (which provide confidence levels of respectively 95 % and 95,45 % in the case where the distributions characterizing the actual measurement uncertainties are normal (Gaussian)).

Table 5 is based on such expansion factors.

6.7 Test conditions power sources and ambient temperatures

6.7.1 Normal and extreme test conditions

Conformity testing shall be carried out under normal test conditions (clause 6.8) and also where stated under extreme test conditions (clauses 6.9.1 and 6.9.2 applied simultaneously).

6.7.2 Test power source

Where stated, the battery of the equipment shall be replaced by a test power source capable of producing normal (clause 6.8.2) and extreme test voltages as specified in clauses 6.9.2.1 and 6.9.2.2.

6.8 Normal test conditions

6.8.1 Normal temperature and humidity

Normal temperature and humidity conditions for tests shall be any convenient combination of temperature and humidity, within the following ranges:

- Temperature: +15 °C to +35 °C.
- Relative humidity: 20 % to 75 %.

6.8.2 Normal test voltage

The normal test voltage shall be determined in each case and shall be the voltage corresponding to the voltage that a fresh battery gives at normal temperature and humidity at a load equal to that of the equipment when activated.

6.9 Extreme test conditions

6.9.1 Extreme temperatures

For tests at extreme temperatures, measurements shall be made in accordance with the procedure specified in clause 6.9.1.1 at the lower and upper temperatures of -20 °C and +55 °C respectively except when installed within other equipment subject to more stringent temperature requirements, in which case the more stringent requirements shall apply.

6.9.1.1 Procedure for tests at extreme temperatures

The equipment shall be switched off during the temperature stabilization period.

Before tests are carried out, the equipment shall have obtained thermal balance in the test chamber and have been activated for a period of 5 minutes.

The location of the equipment under test in the climatic chamber shall not substantially influence the power output or the power consumption of the equipment under test.

6.9.2 Extreme test voltages

6.9.2.1 Upper extreme test voltage

The upper extreme test voltage shall be determined in each case and shall be the voltage corresponding to the voltage that a fresh battery gives at the upper extreme temperature with a load equal to that of the equipment when activated.

6.9.2.2 Lower extreme test voltage

The lower extreme test voltage shall be determined in each case. The equipment fitted with a primary battery shall be placed in a climatic chamber and cooled to -20 °C allowing a stabilization period of 2 hours. The equipment shall then be activated for a period of 6 hours. After this period the battery voltage shall be measured. This voltage shall be taken as the lower extreme test voltage and shall be measured before disconnecting the battery.

7 Environmental tests

7.1 Introduction

The requirements of this clause demonstrate that the equipment is capable of continuous operation under the conditions of various sea states, vibration, humidity and change of temperature likely to be experienced on a ship in which it is carried.

7.2 Procedure

Environmental tests shall be carried out before tests in respect of the other requirements in the present document are performed on the same EUT. Environmental tests may be carried out in any order but the test specified in clause 7.13 shall always be carried out last so as to detect any damage to EUT's water seals caused by the other environmental tests.

7.3 Performance check

The term performance check as used in the present document shall be a performance check consists of activating the locating beacon in test mode with GNSS data available, and checking the reception of Message 1 and Message 14 using a suitable AIS receiver.

The performance check shall be carried out only under normal test conditions as detailed in clause 6.8.1 unless otherwise stated.

7.4 Drop test

7.4.1 Definition

The immunity against the effects of dropping is the ability of the equipment to maintain the specified mechanical and electrical performance after being subjected to a series of drops onto (i) a hard wooden test surface and (ii) into water.

7.4.2 Test conditions

During the test, the equipment shall be fitted with a suitable set of batteries and antenna but it shall be switched off. The test shall be carried out under normal temperature and humidity conditions as detailed in clause 6.8.1.

The hard wooden test surface shall consist of a piece of solid hard wood with a minimum thickness of 15 cm and a mass of at least 30 kilograms.

A container of calm fresh water shall be used as the other surface.

The height of the lowest part of the equipment under test, relative to the test surface at the moment of release, shall be:

- (i) For drops onto the wooden test surface - 1 m.
- (ii) For drops onto the water - 20 m.

Equipment shall be subjected to this test in the configuration as it is normally used in operational circumstances.

7.4.3 Method of measurement

For drop into water the test shall consist of a single drop test, and the test shall be performed on the EUT complete with any detachable shock absorbers, which are normally part of it (e.g. a life vest).

For drops on the wooden surface the test shall consist of six drops, once on each face, and the test shall be performed on the EUT alone excluding detachable shock absorbers.

7.4.4 Requirements

After the drops have been completed the equipment shall be inspected visually for signs of damage. Inspection for mechanical damage, both internal and external, shall be carried out. Any damage shall not impair the operation of the equipment. In particular, parts like knobs, switches and the antenna shall operate in the normal manner. The act of dropping shall not cause the equipment to operate.

The requirement for the performance check shall also be met.

7.5 Temperature tests

7.5.1 Definition

The immunity against the effects of temperature is the ability of the equipment to maintain the specified mechanical and electrical performance after the following tests have been carried out.

The maximum rate of raising or reducing the temperature of the chamber in which the equipment is being tested shall be 1 °C/minute.

7.5.2 Dry heat test

7.5.2.1 Method of measurement

The EUT shall be placed in a chamber at normal room temperature and relative humidity. The EUT and, if appropriate, any climatic control devices with which it is provided shall then be switched on. The temperature shall then be raised to and maintained at +55 °C (± 3 °C). At the end of the period of 10 hours to 16 hours at +55 °C (± 3 °C), the EUT shall be subjected to the performance check. The temperature of the chamber shall be maintained at +55 °C (± 3 °C) during the whole of the performance check period. At the end of the test, the EUT shall be returned to normal environmental conditions or to those at the start of the next test.

7.5.2.2 Requirement

The requirement for the performance check shall be met.

7.5.3 Damp heat test

7.5.3.1 Method of measurement

The EUT shall be placed in a chamber at normal room temperature and relative humidity. The temperature shall then be raised to +40 °C (± 2 °C), and the relative humidity raised to 93 % (± 3 %) over a period of 3 hours \pm 0,5 hours. These conditions shall be maintained for a period of 10 hours to 16 hours.

The EUT shall be switched on 30 minutes later, or after such period as agreed with the manufacturer, and shall be kept operational for at least 2 hours during which period the EUT shall be subjected to the performance check. The temperature and relative humidity of the chamber shall be maintained as specified during the whole test period.

At the end of the test period and with the EUT still in the chamber, the chamber shall be brought to room temperature in not less than 1 hour. At the end of the test the EUT shall be returned to normal environmental conditions or to those required at the start of the next test.

7.5.3.2 Requirement

The requirement for the performance check shall be met.

7.5.4 Low temperature test

7.5.4.1 Method of measurement

The EUT shall be placed in a chamber at normal room temperature and relative humidity. The temperature shall then be reduced to, and be maintained at, -15 °C (± 3 °C) for a period of 10 hours to 16 hours. Any climatic control devices provided in the EUT may be switched on at the conclusion of this period. The EUT shall be switched on 30 minutes later, or after such period as agreed by the manufacturer, and shall be kept operational for at least 2 hours during which period the EUT shall be subjected to a performance check. The temperature of the chamber shall be maintained at -15 °C (± 3 °C) during the whole of the test period. At the end of the test the EUT shall be returned to normal environmental conditions or to those required at the start of the next test.

Throughout the test the equipment shall be working normally.

7.5.4.2 Requirement

The requirement for the performance check shall be met.

7.6 Vibration test

7.6.1 Definition

The immunity against the effects of vibration is the ability of the equipment to maintain the specified mechanical and electrical performance when the following test is carried out.

7.6.2 Method of measurement

The equipment, complete with any detachable shock absorbers that are normally part of it (e.g. a life vest), shall be clamped to the vibration table by its normal means of support and in its normal attitude.

The equipment may be suspended to compensate for weight not capable of being withstood by the vibration table.

Provisions may be made to reduce or nullify any adverse effect on the equipment performance which may be caused by the presence of any electro-magnetic fields from the vibration table.

Taking at least 15 minutes to cover each octave of frequency, the equipment shall be subjected to sinusoidal vertical vibration at all frequencies between:

- 2 Hz or 5 Hz and 13,2 Hz with an excursion of ± 1 mm \pm 10 %;

- 13,2 Hz and 100 Hz with a constant maximum acceleration of 7 m/s/s.

A resonance search shall be carried out during the vibration test. If any resonance of the EUT has Q greater than 5 measured relative to the base of the vibration table, the EUT shall be subjected to a vibration endurance test at each resonant frequency at the vibration level specified in the test with a duration of 2 h. If no resonance with Q greater than 5 occurs the endurance test shall be carried out at one single observed frequency. If no resonance occurs the endurance test shall be carried out at a frequency of 30 Hz.

The test shall be repeated with vibration in each of the mutual perpendicular direction in the horizontal plane.

A performance check shall be carried out at least once during each endurance test period and once before the end of each endurance test period.

7.6.3 Requirement

The locating beacon shall not automatically activate during the vibration test.

The requirement for the performance check shall be met. No damage or mechanical deterioration shall be visible to the naked eye. The EUT if tested with a vibration absorber (e.g. a life jacket) shall not become detached.

7.7 Corrosion test

This test need not be carried out if the manufacturer produces sufficient evidence that the components, materials, etc. maintain their specified mechanical and electrical performance against the effects of corrosion.

7.7.1 Definition

The immunity against the effects of corrosion is the ability of the equipment to maintain the specified mechanical and electrical performance after the following test has been carried out.

7.7.2 Method of measurement

The equipment shall be placed in a chamber fitted with apparatus capable of spraying in the form of fine mist, such as would be produced by a spray gun, salt solution to the formula in table 6.

Table 6: Salt solution formula

sodium chloride	26,5	g	±10 %
magnesium chloride	2,5	g	±10 %
magnesium sulphate	3,3	g	±10 %
calcium chloride	1,1	g	±10 %
potassium chloride	0,73	g	±10 %
sodium bicarbonate	0,20	g	±10 %
sodium bromide	0,28	g	±10 %
plus distilled water to make the solution up to 1 l.			

Alternatively a 5 % sodium chloride (NaCl) solution may be used. The salt used for the test shall be high quality sodium chloride (NaCl) containing, when dry, not more than 0,1 % sodium iodide and not more than 0,3 % of total impurities.

Salt solution concentration shall be 5 % (±1 %) by weight. The solution shall be prepared by dissolving 5 parts ±1 by weight of salt in 95 parts by weight of distilled or de-mineralized water.

The pH value of the solution shall be between 6,5 and 7,2 at temperature of 20 °C (±2 °C). The pH value shall be maintained within this range during conditioning. For this purpose, diluted hydrochloric acid or sodium hydroxide may be used to adjust the pH value, provided that the concentration of NaCl remains within the prescribed limits. The pH value shall be measured when preparing each new batch of solution.

The spraying apparatus shall be such that the products of corrosion cannot mix with the salt solution contained within the spray reservoir.

The equipment shall be sprayed simultaneously on all its external surfaces with the salt solution for a period of 1 hour. This spraying shall be carried out 4 times with a storage period of 7 days; at 40 °C (± 2 °C) after each spraying. The relative humidity during storage shall be maintained between 90 % and 95 %.

At the end of the total period the equipment shall be examined visually.

7.7.3 Requirements

There shall be no undue deterioration or corrosion of the metal parts, finishes, material, or component parts visible to the naked eye.

In the case of hermetically sealed equipment there shall be no evidence of moisture penetration.

7.8 Thermal shock test

7.8.1 Definition

The immunity against the effects of thermal shock is the ability of the equipment to maintain the specified mechanical and electrical performance after the following test has been carried out.

7.8.2 Method of measurement

The equipment shall be placed in an atmosphere of +65 °C (± 3 °C) for 1 hour. It shall then be immersed in water at +4 °C (± 3 °C) to a depth of 10 cm, measured from the highest point of the equipment to the surface of the water, for a period of 1 hour.

7.8.3 Requirements

The requirement for the performance check shall be met. No damage shall be visible to the naked eye and the equipment shall not show any sign of significant external damage or harmful penetration of water.

7.9 Buoyancy test

7.9.1 Definition

Buoyancy, expressed as a percentage, is its buoyant force divided by its gravity force.

7.9.2 Method of measurement

For Category 1 equipment the radio beacon shall be submerged in calm fresh water.

For Category 2 equipment the radio beacon and its buoyancy device shall be submerged in calm fresh water.

One of the following methods of measurement shall be used:

- the buoyant force shall be measured when the radio beacon is totally submerged in fresh water. The buoyant force shall be then divided by the measured gravity force. The result shall be recorded; or
- the buoyancy may be calculated by dividing the volume of the unit above the waterline by the total volume of the radio beacon. The result shall be recorded.

7.9.3 Requirements

The value of buoyancy shall be at least 5 %.

7.10 Compass safe distance test

7.10.1 Definition

The compass safe distance is the closest distance to compasses or compass sensors (flux gate, magnetometer) at which the locating beacon is safe to be stored.

The compass-safe distance D_{\min} is defined as the distance between the nearest point of the locating beacon and the centre of the compass or magnetometer at which it will just produce a deviation in the measurement compass or compass sensor of X°/H where:

- X is $5,4^\circ$ for the standard compass and 18° for the steering compass, the standby steering compass and the emergency compass.
- H is the horizontal component of the magnetic flux density in μT of the earth's Geomagnetic field at the place of testing.

7.10.2 Method of measurement

The locating beacon shall be tested in the position and attitude relative to the compass or compass sensor at which the error produced at the compass would be a maximum (figure 3).

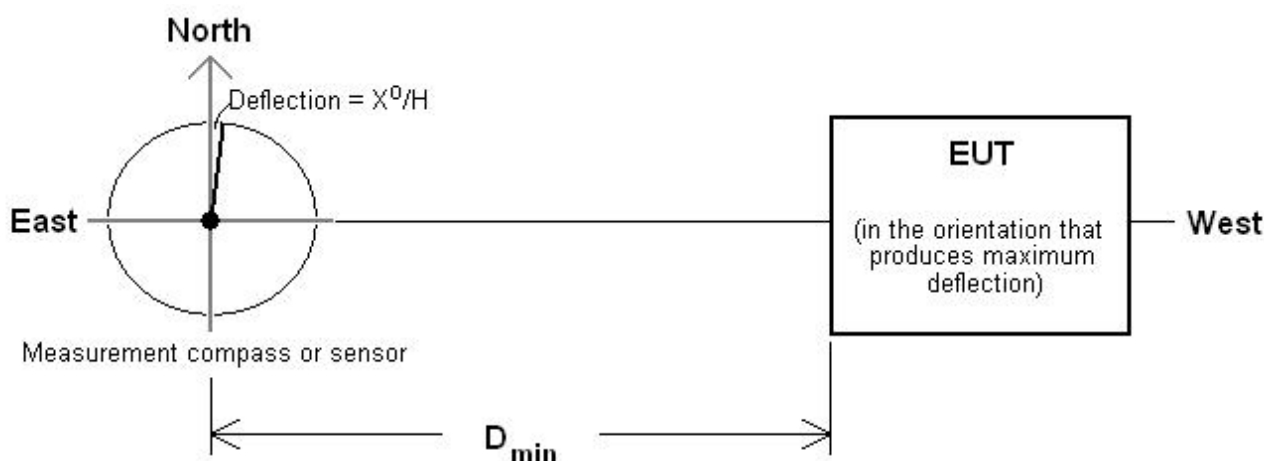

Figure 3: Compass safe distance test set up

Steps should be taken to ensure the Geomagnetic field at the test site is uniform.

With the EUT removed from the test side the measurement compass or compass sensor is aligned with magnetic north so that the measured deflection is 0° .

The locating beacon to be tested (EUT) is then placed in the same plane and on an east west line passing through the centre of the measurement compass or compass sensor. The measurement compass or compass sensor remains stationary and the EUT is moved along the line until the required deflection X°/H is observed. At this position the EUT is re-oriented until the deflection is maximized. The EUT is then moved again along the east west line until the required deflection X°/H is again observed. The distance D_{\min} between the centre of the measurement compass or compass sensor and the nearest point of the EUT is recorded.

7.10.3 Requirements

The minimum distance to obtain the required deflection D_{\min} shall be recorded in the test report.

7.11 Solar radiation test

This test need not be carried out if the manufacturer produces sufficient evidence that the components, materials, etc. maintain their specified mechanical and electrical performance against the effects of continuous solar radiation.

7.11.1 Definition

The immunity against the effects of continuous solar radiation is the ability of the equipment to maintain the specified mechanical and electrical performance after the following test has been carried out.

7.11.2 Method of measurement

The equipment shall be placed on a suitable support and exposed continuously to a simulated solar radiation source (table 7) for 80 hours.

The intensity at the test point, which shall also include any radiation reflected from the test enclosure, shall be $1\,120\text{ W/m}^2 \pm 10\%$ with a spectral distribution given in table 7.

Table 7: Spectral distribution

Spectral Region	Ultra-violet B	Ultra-violet A	Visible			Infra-red
Bandwidth { μm }	0,28 to 0,32	0,32 to 0,40	0,40 to 0,52	0,52 to 0,64	0,64 to 0,78	0,78 to 3,00
Radiance { W/m^2 }	5	63	200	186	174	492
Tolerance {%}	± 35	± 25	± 10	± 10	± 10	± 10

NOTE: Radiation shorter than $0,30\ \mu\text{m}$ reaching the earth's surface is insignificant.

7.11.3 Requirements

No damage shall be visible to the naked eye and the equipment shall not show any sign of significant external damage or harmful penetration of water.

7.12 Oil resistance test

This test need not be carried out if the manufacturer produces sufficient evidence that the components, materials, etc. maintain their specified mechanical and electrical performance against the effects of corrosion.

7.12.1 Definition

The immunity against the effects of immersion in mineral oil is the ability of the equipment to maintain the specified mechanical and electrical performance after the following test has been carried out.

7.12.2 Method of measurement

The equipment shall be immersed horizontally for a period of 24 hours under a 100 mm head of mineral oil as specified below at normal room temperature.

- aniline point: 120 °C;
- flash point: minimum 240 °C;
- viscosity: 10 - 25 cSt at 99 °C.

The following oils may be used:

- ASTM Oil No. 1;

- ASTM Oil No. 5;
- ISO Oil No. 1.

7.12.3 Requirements

No sign of damage such as shrinking, cracking, swelling, dissolution or change of mechanical qualities of the locating beacon, including labelling, shall be visible to the naked eye.

7.13 Protection of the transmitter

7.13.1 Definition

When operating, the locating beacon transmitter shall not be damaged due to antenna mismatching and shall remain water-tight.

7.13.2 Method of measurement

With the transmitter operating, the equipment shall be completely immersed in water to a depth of 1 m for a period of 5 minutes. For equipment fitted with an extendible antenna, the test shall be carried out with the antenna fully extended, and repeated with the antenna fully retracted under normal test conditions.

Saline solution of normal sea saltness (see corrosion test).

7.13.3 Requirement

No damage shall be visible to the naked eye and the equipment shall not show any sign of significant external damage or harmful penetration of water, and the requirements of the performance check shall be met.

8 Tests on the AIS transmitter

8.1 Frequency error

8.1.1 Definition

The frequency error of the transmitter is the difference between the measured carrier frequency in the absence of modulation and its required frequencies AIS1 and AIS2.

8.1.2 Method of measurement

The carrier frequency shall be measured with the equipment placed in the test fixture (clause 6.4). The measurement shall be made using the test power source (see clause 6.7.2) under both normal and extreme test conditions. The carrier frequency shall be measured in the absence of modulation. The test shall be performed on AIS1 and AIS2.

8.1.3 Limit

The frequency error under normal conditions shall not exceed ± 3 ppm, and under extreme test conditions shall not exceed ± 6 ppm.

8.2 Conducted Power

The purpose of this test is to verify that the output power from the locating beacon is within limits at extreme operating temperatures.

Note that the conducted power delivered to an artificial antenna is likely to be greater than the measured ERP (clause 8.3) due to absorption by the salty man support (see clause A.4).

8.2.1 Definition

This is the average or mean power delivered to the artificial antenna (see clause 6.4) in the absence of modulation.

8.2.2 Method of measurement under normal test conditions

The transmitter shall be connected to an artificial antenna (see clause 6.4) and the average or mean power delivered to this artificial antenna shall be measured under normal conditions (see clause 6.8), and at the extremes of temperature (see clause 6.9.1).

A measurement for frequency AIS1 shall be made and repeated for AIS2.

The mean power under normal conditions P_{Norm} shall be measured.

The mean power under extreme conditions P_{-20} and P_{+55} shall be measured.

The differences between the normal and extreme conditions shall be determined:

- $P_{\text{diff1}} = P_{\text{Norm}} - P_{-20}$ and $P_{\text{diff2}} = P_{\text{Norm}} - P_{+55}$

8.2.3 Limit

The difference between the conducted power under extreme conditions and the conducted power under normal conditions shall be less than ± 3 dB for both AIS1 and AIS2.

8.3 Maximum Effective Radiated Power (ERP)

8.3.1 Definition

The Effective Radiated Power (ERP) is the power radiated in the direction of the maximum field strength under the specified conditions of measurements.

8.3.2 Method of measurement

The measurement is made under normal conditions (see clause 6.8) for frequency AIS1 and repeated for AIS2.

On a test site selected from annex A, the equipment shall be placed on the support and according to the requirements of clause A.4 for equipment intended to be worn on a person. The transmitter shall be switched on to transmit continuously without modulation.

The receiver shall be tuned to the transmitter carrier frequency. The test antenna shall be orientated for vertical polarization. The test antenna shall be raised or lowered through the specified range of heights until a maximum signal level is detected on the measuring receiver.

The transmitter shall be rotated through 360° around a vertical axis in order to find the direction of the maximum signal.

The maximum signal level detected by the measuring receiver shall be noted.

The transmitter shall be replaced by a substitution antenna as defined in annex A.

The substitution antenna shall be connected to a calibrated signal generator.

The frequency of the calibrated signal generator shall be adjusted to the transmit carrier frequency.

The input attenuator setting of the measuring receiver shall be adjusted in order to increase the sensitivity of the measuring receiver, if necessary.

The test antenna shall be raised or lowered through the specified range of heights to ensure that the maximum signal is received.

The input signal to the substitution antenna shall be adjusted to the level that produces a level detected by the measuring receiver that is equal to the level noted to that detected from the equipment under test corrected for the change in input attenuator setting of the measuring receiver.

The maximum ERP is equal to the power supplied by the signal generator, increased by the gain of the substitution antenna and corrected for the change in the attenuator.

8.3.3 Limits

The ERP shall be at least 25 mW, and not more than 600 mW.

NOTE: The maximum ERP is subject to review and administrative coordination.

8.4 Transmitter spectrum mask

8.4.1 Definition

The transmitter spectrum mask defines the limits within the range $f_c \pm 75$ kHz for the peak power of all modulated signals including all side bands associated with the carrier.

8.4.2 Method of measurement

The transmitter shall be connected to an artificial antenna (see clause 6.4) with a means of measuring the power delivered to the load. The equipment shall be operated from the test power source (clause 6.7.2). Standard test signal number 3 (see clause 6.5.3) shall be used to modulate the transmitter in repeated packets.

The measurement shall be made under normal test conditions.

To determine the reference peak power and measure the emissions in the adjacent channels, the emission is suitably applied to the input of a spectrum analyser with the following preferred settings:

- Resolution bandwidth: 1 kHz;
- Video bandwidth: 3 kHz;
- Scan bandwidth: 150 kHz;
- Centre frequency: Carrier frequency AIS1 and AIS2;
- Detector type: Peak hold.

A sufficient number of sweeps shall be used and sufficient transmission packets measured to ensure that the emission profile is fully developed. A reference carrier power shall be calculated as being the maximum power within the frequency limits set in clause 8.1.3. The emission profile shall then be normalized so that the reference carrier power is set to 0 dBc. The result is compared to the mask given in figure 4.

A measurement for frequency AIS1 shall be made and repeated for AIS2.

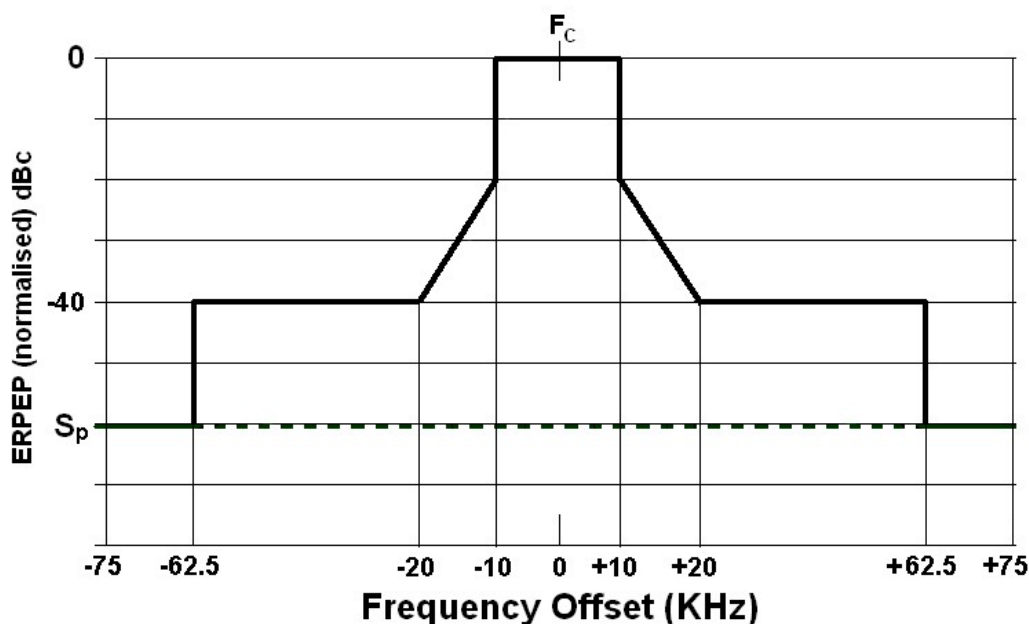

Figure 4: Transmitter spectrum mask

The mask is set as follows:

For ± 10 kHz the limit is 0 dBc. From ± 10 kHz to ± 20 kHz the limit decreases linearly from -20 dBc to -40 dBc. From ± 20 kHz to $\pm 62,5$ kHz the limit is -40 dBc. From $\pm 62,5$ kHz to ± 75 kHz the line S_p shall be used as the mask.

S_p is the normalized spurious emission limit (clause 8.8.3): $S_p = -37 - ERP$ (as measured in clause 8.3.2) dBc.

8.4.3 Limit

The normalized emission profile shall not exceed the mask of figure 4.

8.5 Transmitter transient behaviour (output power)

8.5.1 Definition

The transient behaviour (output power) of the transmitter is determined by the time-dependency of the transmitter power when the transmitter output power is switched on and off. Within the scope of the present document, only the transmit power as a function of time is tested as shown in figure 5 and defined in table 8 where:

- transmitter delay time ($T_A - T_0$) is the time between the start of the slot and the moment when the transmit power may exceed -50 dB of the steady-state power (P_{ss});
- transmitter attack time ($T_{B2} - T_A$) is the time between the transmit power exceeding -50 dBc and the moment when the transmit power maintains a level within +1,5 dB - 1 dB from P_{ss} ;
- transmitter release time ($T_F - T_E$) is the time between the end flag being transmitted and the moment when the transmitter output power has reduced to a level 50 dB below P_{ss} and remains below this level thereafter;
- transmission duration ($T_F - T_A$) is the time from when power exceeds -50 dBc to when the power returns to and stays below -50 dBc.

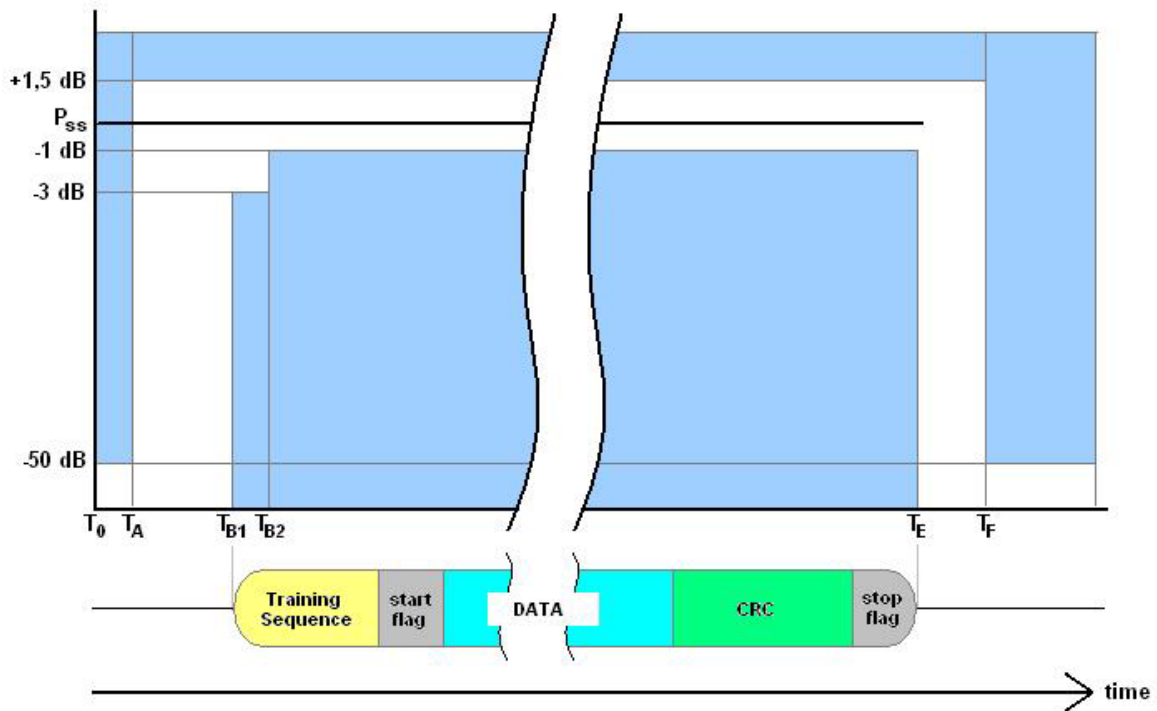

Figure 5: Power versus time mask

Table 8: Definitions of timings

Reference	Bit Periods	Time (ms)	Definition
T_0	0	0	Start of transmission slot. Power shall NOT exceed -50 dB of P_{SS} before T_0
T_A	0 to 6	0 to 0,625	T_A = Point at which power exceeds -50 dB of P_{SS}
T_B	T_{B1}	6	Power shall be within +1,5 or -3 dB of P_{SS}
	T_{B2}	8	Power shall be within +1,5 or -1 dB of P_{SS}
T_E (includes 1 stuffing bit)	233	24,271	Power shall remain within +1,5 or -1 dB of P_{SS} during the period T_{B2} to T_E (see note)
T_F (includes 1 stuffing bit)	241	25,104	Power shall be \leq -50 dB of P_{SS} and stay below this
T_G	256	26,667	Start of next transmission time period
NOTE: There shall be no modulation of the RF after the termination of transmission (T_E) until the power has reached zero and the next slot begins (T_G).			

8.5.2 Method of measurement

The measurement is made under normal conditions (see clause 6.7) for frequency AIS1 and repeated for AIS2.

The transmitter shall be connected to an artificial antenna (see clause 6.4). The measurement shall be carried out by transmitting test signal number 1.

A spectrum analyser shall be used to make the measurements with the following preferred settings:

- Resolution bandwidth: 1 MHz;
- Video bandwidth: 1 MHz;
- Scan bandwidth: zero span;
- Centre frequency: Carrier frequency as measured in clause 8.1;
- Detector type: sample detector [single sweep mode].

The spectrum analyser shall be synchronized to the nominal start time of the slot (T_0), which is provided by a modified sample of the EUT submitted by the manufacturer (clause 6.5.4).

8.5.3 Limit

The transmitter power shall remain within the mask shown in figure 5 and associated timings given in table 8.

8.6 Transmitter Transient Behaviour (frequency deviation)

8.6.1 Definition

The transient behaviour (frequency deviation) of the transmitter is determined by the time-dependency of the frequency deviation during the transmission of an AIS message.

A test to verify that the training sequence starts with a 0 and is a 0101 pattern of 24 bits. The peak frequency deviation is derived from the baseband signal to verify modulation accuracy.

8.6.2 Method of measurement

The measurement is made under normal and extreme conditions (see clauses 6.7 and 6.8) for frequency AIS1 and repeated for AIS2.

The transmitter shall be connected to an artificial antenna (see clause 6.4) comprising a power attenuator and a suitable measuring device either option A or option B of figure 6.

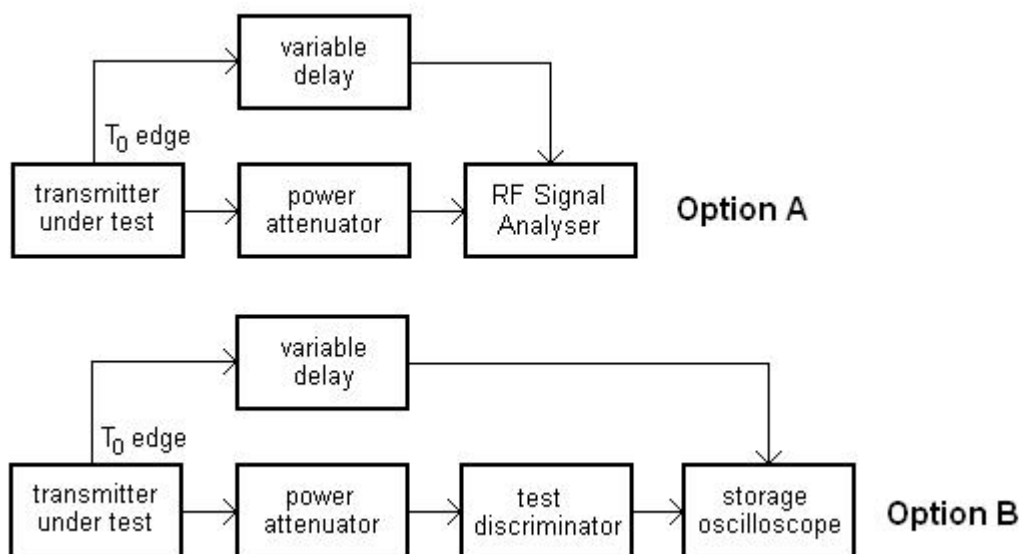

Figure 6: Measurement arrangement for modulation accuracy

The measuring device shall be synchronized to the nominal start time of the first preamble bit (T_B), using the modified sample of the EUT submitted by the manufacturer (clause 6.5.4). Using test signal 2 the delay from the T_0 timing edge provided by EUT (see clause 6.5.4) is adjusted until the centre position of the first data bit (bit 0) is determined as the trigger point T_B . Holding these settings test signal 2 is replaced with test signal 1 to confirm that T_B has been correctly determined.

The transmitter shall be modulated with test signal number 2.

The deviation from the carrier frequency shall be measured as a function of time.

The transmitter shall be modulated with test signal number 1.

The deviation from the carrier frequency shall be measured as a function of time.

8.6.3 Limit

In each case the observed training sequence shall begin with a '0'

The peak frequency deviation at various points within the data frame shall comply with table 8. These limits apply to both the positive and negative modulation peaks. Bit 0 is defined as the first bit of the training sequence.

Table 9: Peak frequency deviation versus time

Measurement period from centre to centre of each bit	Test signal 1		Test signal 2	
	Normal	Extreme	Normal	Extreme
Bit 0 to bit 1	<3 400 Hz			
Bit 2 to bit 3	2 400 Hz \pm 480 Hz			
Bit 4 to bit 31	2 400 Hz \pm 240 Hz	2 400 Hz \pm 480 Hz	2 400 Hz \pm 240 Hz	2 400 Hz \pm 480 Hz
Bit 32 to bit 199	1 740 Hz \pm 175 Hz	1 740 Hz \pm 350 Hz	2 400 Hz \pm 240 Hz	2 400 Hz \pm 480 Hz

8.7 Synchronization accuracy

8.7.1 Definition

The synchronization accuracy defines the allowable time deviation including additive jitter in the transmission of an AIS message from ideal SOTDMA timing. The synchronization accuracy test verifies:

- (i) That the EUT will not transmit unless it acquires UTC lock.
- (ii) That the EUT transmission will be properly synchronized once UTC lock is acquired.
- (iii) That following UTC lock the EUT will continue properly synchronized transmission if UTC lock is subsequently lost, and will stop transmitting once it can no longer guarantee synchronization accuracy.

This test requires analysis of the transmissions of the EUT in active mode. Where there is a possibility that any transmissions might be picked up by a nearby AIS receiver such as a coastal shore station, the EUT shall be tested in training mode instead.

8.7.2 Method of measurement

The EUT shall be programmed with a valid almanac as described in the user documentation.

The measurement is made under normal and extreme conditions (see clauses 6.8 and 6.9) for frequency AIS1 and repeated for AIS2.

The transmitter shall be connected to an artificial antenna (see clause 6.4). The EUT's GNSS receiver shall be connected to a GNSS simulator that additionally provides a UTC output and a 1 pps reference output with an accuracy of ± 1 μ S or better (figure 7).

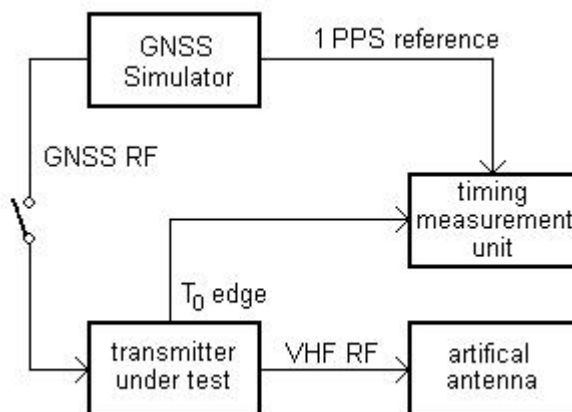

Figure 7: Measurement arrangement for synchronization accuracy

- 1) The EUT shall be activated in active mode with the GNSS signal interrupted and transmissions recorded for 15 minutes.
- 2) Operate the test facility on the EUT with GNSS reception inhibited and record transmissions for 5 minutes.
- 3) With the GNSS signal restored but with only 3 satellites being simulated, activate the EUT in active mode and record transmissions for 15 minutes.
- 4) Operate the test facility on the EUT with the GNSS signal connected but with only 3 satellites being simulated, and record transmissions for 5 minutes.
- 5) Activate the EUT in active mode with GNSS signal connected and more than 3 satellites being simulated and record transmissions for 5 minutes. After 5 minutes inhibit GNSS reception and continue to record transmissions for a further 30 minutes.

Whenever a transmission is recorded the associated timing difference between the EUT generated T_0 (see clause 6.5.4) edge and the GNSS simulator generated 1pps signal shall also be recorded. The EUT may pick any one of 75 slots in any two second period. The legitimate timings for both even and odd seconds are given in table 10.

Table 10: Legitimate T_0 Timings (μs) in any second

Even	Odd	Even	Odd	Even	Odd	Even	Odd
26667	13333	293333	280000	560000	546667	826667	813333
53333	40000	320000	306667	586667	573333	853333	840000
80000	66667	346667	333333	613333	600000	880000	866667
106667	93333	373333	360000	640000	626667	906667	893333
133333	120000	400000	386667	666667	653333	933333	920000
160000	146667	426667	413333	693333	680000	960000	946667
186667	173333	453333	440000	720000	706667	986667	973333
213333	200000	480000	466667	746667	733333	-	-
240000	226667	506667	493333	773333	760000	-	-
266667	253333	533333	520000	800000	786667	-	-

The UTC output from the simulator is used by the timing measurement unit to determine when even or odd slot timing measurements apply. The time difference between a legitimate slot start and the measured T_0 shall be compared to the limit of clause 8.7.2.

8.7.3 Limit

Either the EUT transmits with a synchronization error (including additive jitter) of less than $\pm 312 \mu\text{s}$ or it does not transmit at all.

8.8 Spurious emissions

8.8.1 Definition

Emission(s) on a frequency or frequencies which are outside the necessary bandwidth and the level of which may be reduced without affecting the corresponding transmission of information. Spurious emissions include harmonic emissions, parasitic emissions, intermodulation products, and frequency conversion products, but exclude out-of-band emissions.

8.8.2 Method of measurement

Spurious emissions shall be measured using a test site described in annex A.

The measurement shall be performed with the locating beacon in its standard position (annex A) and according to the requirements of clause A.4 for equipment intended to be worn on a person.

The method of measurement described in clause 8.3 shall be used to search for spurious emissions in the frequency band 30 MHz to 2 GHz, excluding the frequency band tested in clause 8.4.

The measuring receiver shall have a bandwidth of 100 kHz to 120 kHz.

The measurement shall only be performed under normal test conditions (see clause 6.8), the locating beacon being rotated until the maximum emission is detected. The measurement is also made when the locating beacon has been activated but is not transmitting.

8.8.3 Limit

The power of any spurious emission component when transmitting shall not exceed 0,2 μ W.

The power of any spurious emission component when not transmitting shall not exceed 2 nW between 30 MHz and 1 GHz and 20 nW between 1 GHz and 2 GHz.

9 VDL Link layer tests

9.1 Active mode tests

These tests require analysis of the transmissions of the EUT in active mode. Where there is a possibility that any transmissions might be picked up by a nearby AIS receiver such as a coastal shore station the EUT shall be tested in training mode instead.

9.1.1 Method of measurement

Activate the EUT in active mode and record transmissions for 40 minutes. Inhibit GNSS data and record transmissions for a further 20 minutes.

Record the activation time of the EUT.

For all transmitted messages record:

- transmission time (UTC time);
- transmission slot;
- in-slot timing;
- transmission channel;
- message content.

The records will be evaluated in the following test items.

9.1.2 Initialization period - Required results

The following is required.

- a) The first message is transmitted within 60 seconds after activation.
- b) The first message with a valid position is transmitted within 5 minutes.

9.1.3 Message content of Message 1 - Required results

For position reports transmitted after 5 minutes and before 40 minutes the following is required.

- a) Message ID = 1.
- b) Repeat indicator = 0.
- c) User ID as configured in the EUT.
- d) Navigational status = 14 in active mode, or 15 in training mode.
- e) Rate of turn = default.
- f) SOG = actual SOG from GNSS receiver.
- g) Position accuracy = according to the RAIM result if provided, otherwise 0.
- h) Position = actual position from internal GNSS receiver.
- i) Position is updated at least once per minute, for each burst.
- j) COG = actual COG from internal GNSS receiver.
- k) True heading = default.
- l) Time stamp = actual UTC second (0...59).
- m) Verify correct indication according to manufacturer's documentation.

9.1.4 Message content of Message 14 - Required results

The following is required:

- a) Message ID = 14.
- b) Repeat indicator = 0.
- c) Source ID = as configured in the EUT.
- d) Text = "MOB ACTIVE" in active mode, or "MOB TEST" in training mode.

9.1.5 Transmission schedule for Message 1 - Required results

For position reports transmitted after 15 minutes and before 40 minutes the following applies:

- e) Verify that the EUT has operated in sync mode 0 (UTC direct).
- f) The EUT transmits one burst of messages once per minute.
- g) The duration of a burst is 14 s.
- h) A burst consists of 8 messages.
- i) The transmissions in a burst are alternating between AIS1 and AIS2.
- j) Consecutive messages are 75 slots apart and on the other channel.

- k) The same set of slots are used in each burst for 8 minutes.
- l) A new set of slots is randomly selected after 8 minutes.
- m) The first slot of the new set of slots is within the interval of $1 \text{ m} \pm 6$ seconds from the first slot of the previous set of slots, that is the increment is randomly selected in the range 2 025 to 2 475 slots.
- n) The manufacturer is to provide documentation on how the increment is selected randomly.

9.1.6 Communication state of Message 1 - Required results

For position reports transmitted after 5 minutes and before 40 minutes the following applies:

- a) The SOTDMA communication state as defined for message 1 is used.
- b) The sync state = 0.
- c) The time-out starts with 7 for all messages of the first burst after a change in slots.
- d) The time-out value is decremented by 1 for each frame.
- e) The time-out value is reset to 7 after time-out = 0.
- f) The sub message for time-out 3,5,7 = number of received stations (0).
- g) The sub message for time-out 2,4,6 = slot number.
- h) The sub message for time-out 1 = UTC hour and minute.
- i) The sub message for time-out 0 = slot offset to the transmission slot in the next frame.

9.1.7 Transmission schedule of Message 14 - Required results

The following is required:

- a) Message 14 is transmitted every 4 minutes.
- b) The transmissions of Message 14 are alternating between AIS1 and AIS2.
- c) Message 14 is transmitted in a Message 1 slot, replacing the Message 1, on the channel for which the Message 1 was scheduled.
- d) Message 14 did not replace a Message 1 with a time-out value = 0.

9.1.8 Transmission with lost GNSS - Required results

For position reports transmitted after 45 minutes the following applies:

- e) The EUT continues transmission.
- f) The same transmission schedule is used as with GNSS data available.
- g) Communication State Sync state = 3.
- h) SOG = last valid SOG.
- i) Position accuracy = low.
- j) Position = last valid position.
- k) COG = last valid COG.
- l) Time stamp = 62.
- m) RAIM-flag = 0.

- n) Verify correct indication as per manufacturer's documentation.

9.2 Test mode tests with GNSS data available

These tests require analysis of the transmissions of the EUT in test mode.

9.2.1 Method of measurement

Activate the EUT in test mode with GNSS data available and record transmissions.

9.2.2 Required results

The following is required:

- a) The EUT starts transmission after valid GNSS data is available.
- b) A single burst of 8 messages in the correct order and correctly populated as per clause B.3.
- c) User ID as configured in the EUT.
- d) Navigational status = 15 (not defined).
- e) SOG = actual SOG from GNSS receiver.
- f) Position accuracy = according to the RAIM result if provided, otherwise 0.
- g) Position = actual position from internal GNSS receiver.
- h) COG = actual COG from internal GNSS receiver.
- i) Time stamp = actual UTC second (0...59).
- j) The communication state time-out always = 0 with sub message = 0.
- k) The transmission of Messages 1 and 14 stops after one burst of 8 messages.
- l) The text message in Message 14 is "MOB TEST".
- m) Verify correct indication as per manufacturer's documentation.

9.3 Test mode tests without GNSS data available

These tests require analysis of the transmissions of the EUT in test mode.

9.3.1 Method of measurement

Activate the EUT in test mode with no GNSS data available and record transmissions.

9.3.2 Required results

The following is required:

- a) The EUT does not transmit within 5 minutes.

Annex A (normative): Radiated measurements

A.1 Test sites and general arrangements for measurements involving the use of radiated fields

This normative annex introduces three most commonly available test sites, an anechoic chamber, an anechoic chamber with a ground plane and an Open Area Test Site (OATS), which may be used for radiated tests. These test sites are generally referred to as free field test sites. Both absolute and relative measurements can be performed in these sites. Where absolute measurements are to be carried out, the chamber should be verified. A detailed verification procedure is described in TR 102 273, relevant parts 2, 3 and 4 [i.1].

NOTE: To ensure reproducibility and traceability of radiated measurements only these test sites should be used in test measurements.

A.1.1 Anechoic chamber

An anechoic chamber is an enclosure, usually shielded, whose internal walls, floor and ceiling are covered with radio absorbing material, normally of the pyramidal urethane foam type. The chamber usually contains an antenna support at one end and a turntable at the other. A typical anechoic chamber is shown in figure A.1.

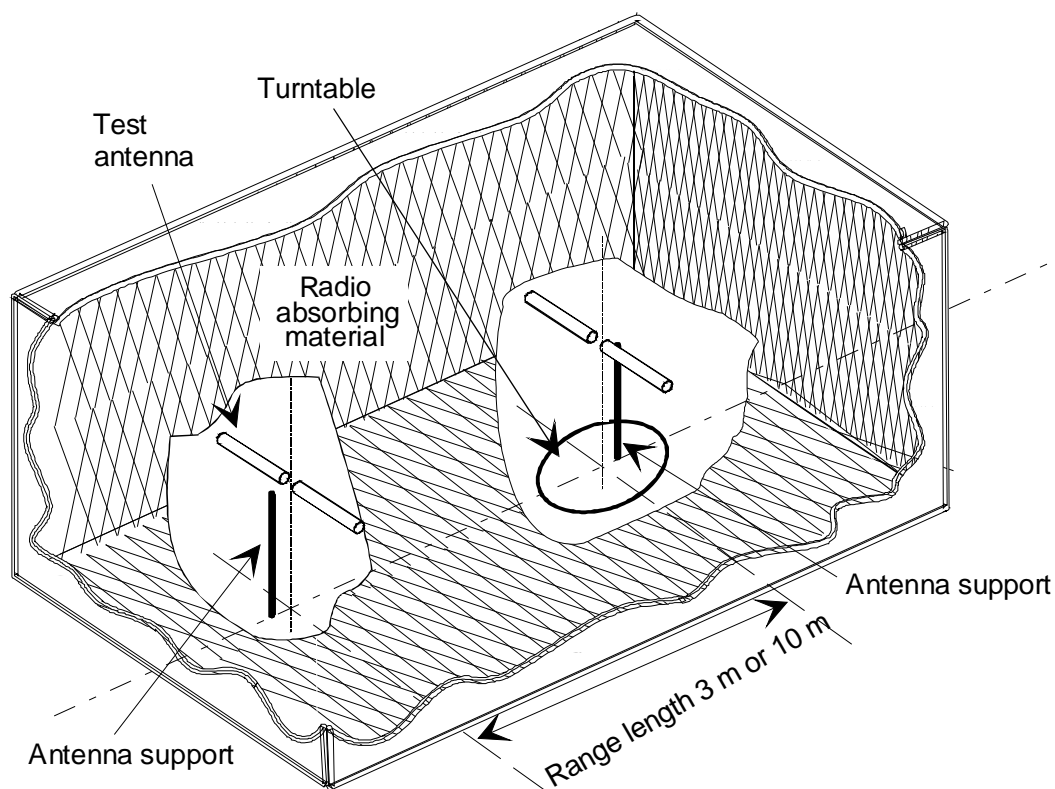

Figure A.1: A typical anechoic chamber

The chamber shielding and radio absorbing material work together to provide a controlled environment for testing purposes. This type of test chamber attempts to simulate free space conditions.

The shielding provides a test space, with reduced levels of interference from ambient signals and other outside effects, whilst the radio absorbing material minimizes unwanted reflections from the walls and ceiling which can influence the measurements. In practice it is relatively easy for shielding to provide high levels (80 dB to 140 dB) of ambient interference rejection, normally making ambient interference negligible.

A turntable is capable of rotation through 360° in the horizontal plane and it is used to support the test sample (EUT) at a suitable height (e.g. 1 m) above the ground plane. The chamber shall be large enough to allow the measuring distance of at least 3 m or $2(d_1+d_2)^2/\lambda$ (m), whichever is greater (see clause A.2.5). The distance used in actual measurements shall be recorded with the test results.

The anechoic chamber generally has several advantages over other test facilities. There is minimal ambient interference, minimal floor, ceiling and wall reflections and it is independent of the weather. It does however have some disadvantages which include limited measuring distance and limited lower frequency usage due to the size of the pyramidal absorbers. To improve low frequency performance, a combination structure of ferrite tiles and urethane foam absorbers is commonly used.

All types of emission, sensitivity and immunity testing can be carried out within an anechoic chamber without limitation.

A.1.2 Anechoic chamber with a ground plane

An anechoic chamber with a ground plane is an enclosure, usually shielded, whose internal walls and ceiling are covered with radio absorbing material, normally of the pyramidal urethane foam type. The floor, which is metallic, is not covered and forms the ground plane. The chamber usually contains an antenna mast at one end and a turntable at the other. A typical anechoic chamber with a ground plane is shown in figure A.2.

This type of test chamber attempts to simulate an ideal OATS whose primary characteristic is a perfectly conducting ground plane of infinite extent.

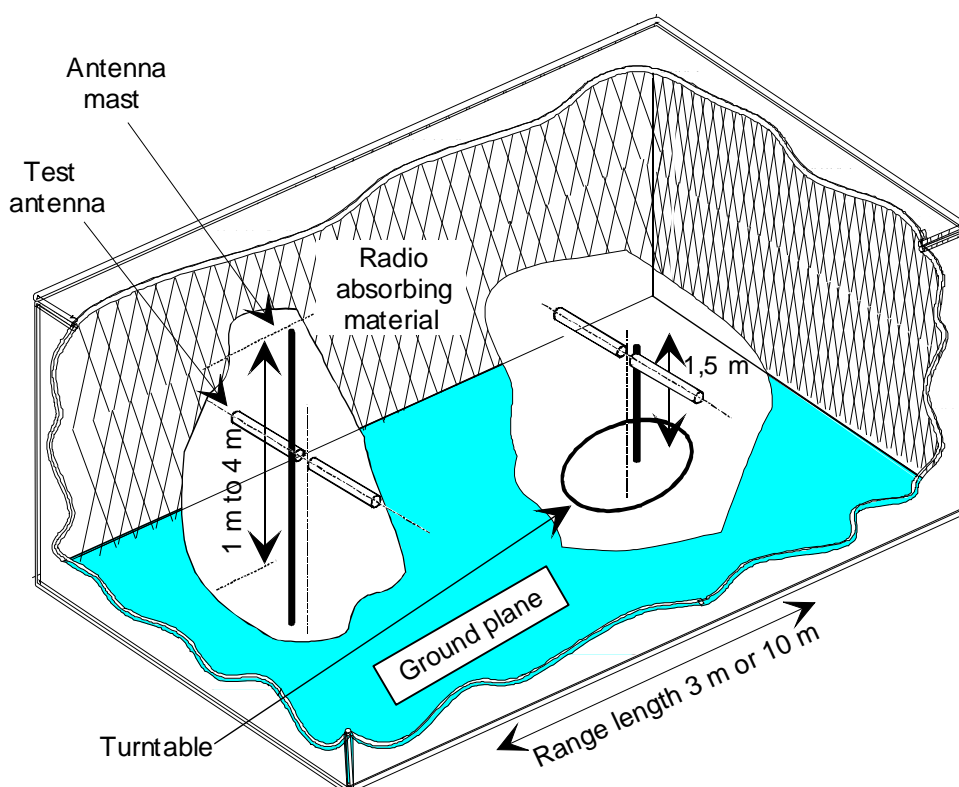

Figure A.2: A typical anechoic chamber with a ground plane

In this facility the ground plane creates the wanted reflection path, such that the signal received by the receiving antenna is the sum of the signals from both the direct and reflected transmission paths. This creates a unique received signal level for each height of the transmitting antenna (or EUT) and the receiving antenna above the ground plane.

The antenna mast provides a variable height facility (from 1 m to 4 m) so that the position of the test antenna can be optimized for maximum coupled signal between antennas or between an EUT and the test antenna.

A turntable is capable of rotation through 360° in the horizontal plane and it is used to support the test sample (EUT) at a specified height, usually 1,5 m above the ground plane. The chamber shall be large enough to allow the measuring distance of at least 3 m or $2(d_1+d_2)^2/\lambda$ (m), whichever is greater (see clause A.2.5). The distance used in actual measurements shall be recorded with the test results.

Emission testing involves firstly "peaking" the field strength from the EUT by raising and lowering the receiving antenna on the mast (to obtain the maximum constructive interference of the direct and reflected signals from the EUT) and then rotating the turntable for a "peak" in the azimuth plane. At this height of the test antenna on the mast, the amplitude of the received signal is noted. Secondly the EUT is replaced by a substitution antenna (positioned at the EUT's phase or volume centre) which is connected to a signal generator. The signal is again "peaked" and the signal generator output adjusted until the level, noted in stage one, is again measured on the receiving device.

Receiver sensitivity tests over a ground plane also involve "peaking" the field strength by raising and lowering the test antenna on the mast to obtain the maximum constructive interference of the direct and reflected signals, this time using a measuring antenna which has been positioned where the phase or volume centre of the EUT will be during testing. A transform factor is derived. The test antenna remains at the same height for stage two, during which the measuring antenna is replaced by the EUT. The amplitude of the transmitted signal is reduced to determine the field strength level at which a specified response is obtained from the EUT.

A.1.3 OATS

An OATS comprises a turntable at one end and an antenna mast of variable height at the other end above a ground plane which, in the ideal case, is perfectly conducting and of infinite extent. In practice, whilst good conductivity can be achieved, the ground plane size has to be limited. A typical OATS is shown in figure A.3.

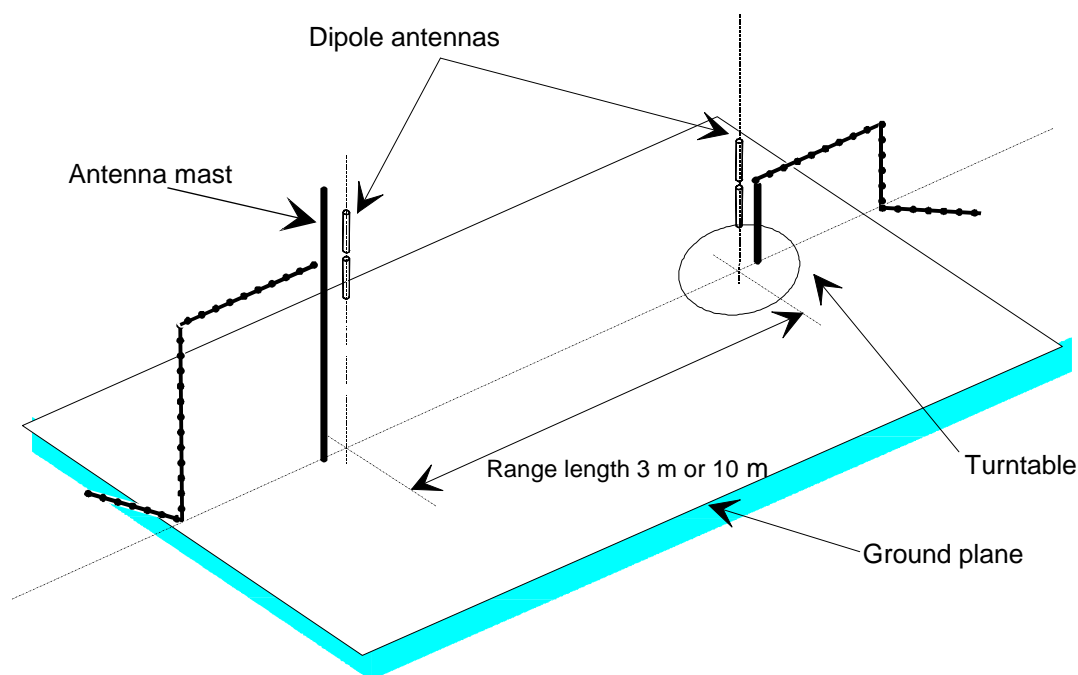

Figure A.3: A typical OATS

The ground plane creates a wanted reflection path, such that the signal received by the receiving antenna is the sum of the signals received from the direct and reflected transmission paths. The phasing of these two signals creates a unique received level for each height of the transmitting antenna (or EUT) and the receiving antenna above the ground plane.

Site qualification concerning antenna positions, turntable, measurement distance and other arrangements are same as for anechoic chamber with a ground plane. In radiated measurements an OATS is also used by the same way as anechoic chamber with a ground plane.

Typical measuring arrangement common for ground plane test sites is presented in figure A.4.

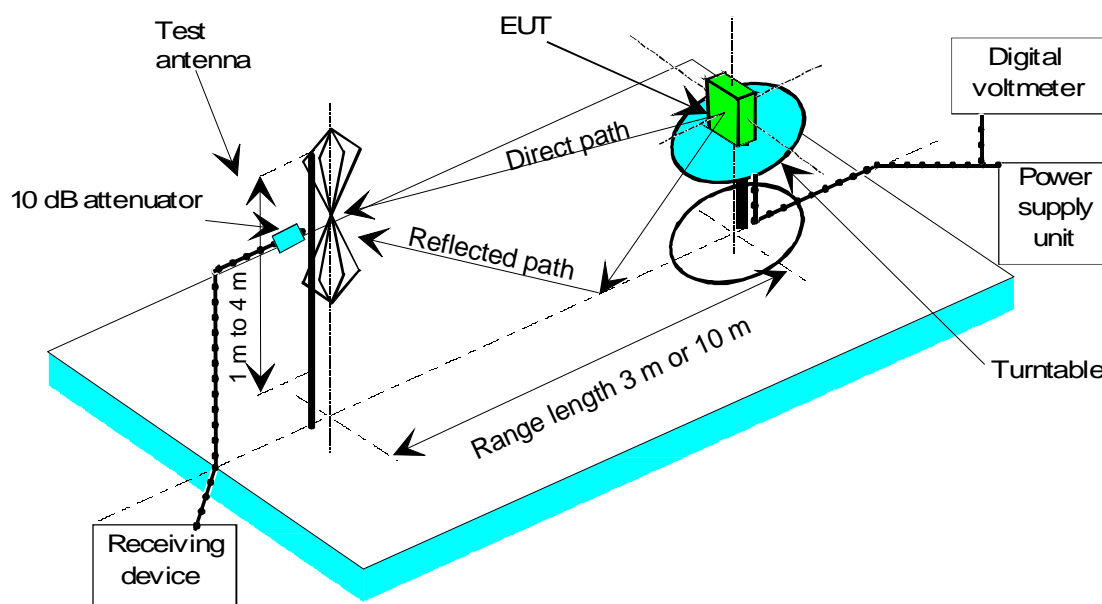

Figure A.4: Measuring arrangement on ground plane test site (OATS set-up for spurious emission testing)

A.1.4 Test antenna

A test antenna is always used in radiated test methods. In emission tests (i.e. frequency error, effective radiated power, spurious emissions and adjacent channel power) the test antenna is used to detect the field from the EUT in one stage of the measurement and from the substitution antenna in the other stage. When the test site is used for the measurement of receiver characteristics (i.e. sensitivity and various immunity parameters) the antenna is used as the transmitting device.

The test antenna should be mounted on a support capable of allowing the antenna to be used in either horizontal or vertical polarization which, on ground plane sites (i.e. anechoic chambers with ground planes and OATS), should additionally allow the height of its centre above the ground to be varied over the specified range (usually 1 m to 4 m).

In the frequency band 30 MHz to 1 000 MHz, dipole antennas (constructed in accordance with ANSI C63.5 [i.2]) are generally recommended. For frequencies of 80 MHz and above, the dipoles should have their arm lengths set for resonance at the frequency of test. Below 80 MHz, shortened arm lengths are recommended. For spurious emission testing, however, a combination of bicones and log periodic dipole array antennas (commonly termed "log periodics") could be used to cover the entire 30 MHz to 1 000 MHz band. Above 1 000 MHz, waveguide horns are recommended although, again, log periodics could be used.

NOTE: The gain of a horn antenna is generally expressed relative to an isotropic radiator.

A.1.5 Substitution antenna

The substitution antenna is used to replace the EUT for tests in which a transmitting parameter (i.e. frequency error, effective radiated power, spurious emissions and adjacent channel power) is being measured. For measurements in the frequency band 30 MHz to 1 000 MHz, the substitution antenna should be a dipole antenna (constructed in accordance with ANSI C63.5 [i.2]). For frequencies of 80 MHz and above, the dipoles should have their arm lengths set for resonance at the frequency of test. Below 80 MHz, shortened arm lengths are recommended. For measurements above 1 000 MHz, a waveguide horn is recommended. The centre of this antenna should coincide with either the phase centre or volume centre (as specified in the test method) of the EUT it has replaced.

A.1.6 Measuring antenna

The measuring antenna is used in tests on an EUT in which a receiving parameter (i.e. sensitivity and various immunity tests) is being measured. Its purpose is to enable a measurement of the electric field strength in the vicinity of the EUT. For measurements in the frequency band 30 MHz to 1 000 MHz, the measuring antenna should be a dipole antenna (constructed in accordance with ANSI C63.5 [i.2]). For frequencies of 80 MHz and above, the dipoles should have their arm lengths set for resonance at the frequency of test. Below 80 MHz, shortened arm lengths are recommended. The centre of this antenna should coincide with either the phase centre or volume centre (as specified in the test method) of the EUT.

A.2 Guidance on the use of radiation test sites

This clause details procedures, test equipment arrangements and verification that should be carried out before any of the radiated test are undertaken. These schemes are common to all types of test sites described in this annex.

A.2.1 Verification of the test site

No test should be carried out on a test site which does not possess a valid certificate of verification. Examples of verification procedures for the different types of test sites described in this annex (i.e. anechoic chamber, anechoic chamber with a ground plane and OATS) are given in TR 102 273, parts 2, 3 and 4 [i.1], respectively.

A.2.2 Preparation of the EUT

The manufacturer should supply information about the EUT covering the operating frequency, polarization, supply voltage(s) and the reference face. Additional information, specific to the type of EUT should include, where relevant, carrier power, CSP, whether different operating modes are available (e.g. high and low power modes) and if operation is continuous or is subject to a maximum test duty cycle (e.g. 1 m on, 4 m off).

Where necessary, a mounting bracket of minimal size should be available for mounting the EUT on the turntable. This bracket should be made from low conductivity, low relative dielectric constant (i.e. less than 1,5) material(s) such as expanded polystyrene, balsa wood, etc.

A.2.3 Power supplies to the EUT

All tests should be performed using power supplies wherever possible, including tests on EUT designed for battery-only use. In all cases, power leads should be connected to the EUT's supply terminals (and monitored with a digital voltmeter) but the battery should remain present, electrically isolated from the rest of the equipment, possibly by putting tape over its contacts.

The presence of these power cables can, however, affect the measured performance of the EUT. For this reason, they should be made to be "transparent" as far as the testing is concerned. This can be achieved by routing them away from the EUT and down to either the screen, ground plane or facility wall (as appropriate) by the shortest possible paths. Precautions should be taken to minimize pick-up on these leads (e.g. the leads could be twisted together, loaded with ferrite beads at 0,15 m spacing or otherwise loaded).

Details shall be included in the test report.

A.2.4 Volume control setting for analogue speech tests

Unless otherwise stated, in all receiver measurements for analogue speech the receiver volume control where possible, should be adjusted to give at least 50 % of the rated audio output power. In the case of stepped volume controls, to volume control should be set to the first step that provides an output power of at least 50 % of the rated audio output power. This control should not be readjusted between normal and extreme test conditions in tests.

A.2.5 Range length

The range length for all these types of test facility should be adequate to allow for testing in the far-field of the EUT i.e. it should be equal to or exceed:

$$\frac{2(d_1+d_2)^2}{\lambda}$$

where:

- d_1 is the largest dimension of the EUT/dipole after substitution (m);
- d_2 is the largest dimension of the test antenna (m);
- λ is the test frequency wavelength (m).

It should be noted that in the substitution part of this measurement, where both test and substitution antennas are half wavelength dipoles, this minimum range length for far-field testing would be:

$$2\lambda$$

It should be noted in the test report when either of these conditions is not met so that the additional measurement uncertainty can be incorporated into the results.

NOTE 1: **For the fully anechoic chamber**, no part of the volume of the EUT should, at any angle of rotation of the turntable, fall outside the "quiet zone" of the chamber at the nominal frequency of the test.

NOTE 2: The "quiet zone" is a volume within the anechoic chamber (without a ground plane) in which a specified performance has either been proven by test, or is guaranteed by the designer/manufacture. The specified performance is usually the reflectivity of the absorbing panels or a directly related parameter (e.g. signal uniformity in amplitude and phase). It should be noted however that the defining levels of the quiet zone tend to vary.

NOTE 3: **For the anechoic chamber with a ground plane**, a full height scanning capability, i.e. 1 m to 4 m, should be available for which no part of the test antenna should come within 1 m of the absorbing panels. For both types of **anechoic chamber**, the reflectivity of the absorbing panels should not be worse than -5 dB.

NOTE 4: **For both the anechoic chamber with a ground plane and the OATS**, no part of any antenna should come within 0,25 m of the ground plane at any time throughout the tests. Where any of these conditions cannot be met, measurements should not be carried out.

A.2.6 Site preparation

The cables for both ends of the test site should be routed horizontally away from the testing area for a minimum of 2 m (unless, in the case both types of **anechoic chamber**, a back wall is reached) and then allowed to drop vertically and out through either the ground plane or screen (as appropriate) to the test equipment. Precautions should be taken to minimize pick up on these leads (e.g. dressing with ferrite beads, or other loading). The cables, their routing and dressing should be identical to the verification set-up.

NOTE: For ground reflection test sites (**i.e. anechoic chambers with ground planes and OATS**) which incorporate a cable drum with the antenna mast, the 2 m requirement may be impossible to comply with.

Calibration data for all items of test equipment should be available and valid. For test, substitution and measuring antennas, the data should include gain relative to an isotropic radiator (or antenna factor) for the frequency of test. Also, the VSWR of the substitution and measuring antennas should be known.

The calibration data on all cables and attenuators should include insertion loss and VSWR throughout the entire frequency range of the tests. All VSWR and insertion loss figures should be recorded in the log book results sheet for the specific test.

Where correction factors/tables are required, these should be immediately available.

For all items of test equipment, the maximum errors they exhibit should be known along with the distribution of the error e.g.:

- cable loss: $\pm 0,5$ dB with a rectangular distribution;
- measuring receiver: 1,0 dB (standard deviation) signal level accuracy with a Gaussian error distribution.

At the start of measurements, system checks should be made on the items of test equipment used on the test site.

A.3 Coupling of signals

A.3.1 General

The presence of leads in the radiated field may cause a disturbance of that field and lead to additional measurement uncertainty. These disturbances can be minimized by using suitable coupling methods, offering signal isolation and minimum field disturbance (e.g. optical and acoustic coupling).

A.3.2 Data signals

Isolation can be provided by the use of optical, ultra sonic or infra red means. Field disturbance can be minimized by using a suitable fibre optic connection. Ultra sonic or infra red radiated connections require suitable measures for the minimization of ambient noise.

A.3.3 Speech and analogue signals

Where an audio output connector is not available an acoustic coupler should be used.

When using the acoustic coupler, care should be exercised that possible ambient noise does not influence the test result.

A.3.3.1 Acoustic coupler description

The acoustic coupler comprises a plastic funnel, an acoustic pipe and a microphone with a suitable amplifier. The materials used to fabricate the funnel and pipe should be of low conductivity and of low relative dielectric constant (i.e. less than 1,5):

- the acoustic pipe should be long enough to reach from the EUT to the microphone which should be located in a position that will not disturb the RF field. The acoustic pipe should have an inner diameter of about 6 mm and a wall thickness of about 1,5 mm and should be sufficiently flexible so as not to hinder the rotation of the turntable;
- the plastic funnel should have a diameter appropriate to the size of the loudspeaker in the EUT, with soft foam rubber glued to its edge, it should be fitted to one end of the acoustic pipe and the microphone should be fitted to the other end. It is very important to fix the centre of the funnel in a reproducible position relative to the EUT, since the position of the centre has a strong influence on the frequency response that will be measured. This can be achieved by placing the EUT in a close fitting acoustic mounting jig, supplied by the manufacturer, of which the funnel is an integral part;
- the microphone should have a response characteristic flat within 1 dB over a frequency range of 50 Hz to 20 kHz, a linear dynamic range of at least 50 dB. The sensitivity of the microphone and the receiver audio output level should be suitable to measure a signal to noise ratio of at least 40 dB at the nominal audio output level of the EUT. Its size should be sufficiently small to couple to the acoustic pipe;
- the frequency correcting network should correct the frequency response of the acoustic coupler so that the acoustic SINAD measurement is valid (see IEC 60489-3 appendix F [i.3]).

A.3.3.2 Calibration

The aim of the calibration of the acoustic coupler is to determine the acoustic SINAD ratio which is equivalent to the SINAD ratio at the receiver output.

A.4 Standard position

The standard position in all test sites, except the stripline arrangement, for equipment which is not intended to be worn on a person, including hand-held equipment, shall be on a non conducting support, height 1,5 m, capable of rotating about a vertical axis through the equipment. The standard position of the equipment shall be the following:

- a) for equipment with an internal antenna, it shall be placed in the position closest to normal use as declared by the manufacturer;
- b) for equipment with a rigid external antenna, the antenna shall be vertical;
- c) for equipment with a non-rigid external antenna, the antenna shall be extended vertically upwards by a non-conducting support.

Equipment which is intended to be worn on a person shall be tested using a salty man as support as described in TR 102 273-7 [3] Artificial human beings.

The simulated man comprises a rotatable acrylic tube filled with salt (NaCl) water with acrylic caps at both ends, placed on the ground.

The preferred dimensions of the container are:

- height: 1,7 m;
- outside diameter: 305 mm;
- sidewall thickness: 4,8 mm.

The container shall be filled with a salt (NaCl) solution of 1,49 g per litre of distilled water ($\sigma = 0,26$ S/m, $\epsilon = 77$).

The equipment shall be fixed to the surface of the simulated man, at the appropriate height for the equipment.

NOTE: To reduce the weight of the simulated man it may be possible to use an alternative tube as described in TR 102 273-7 [3].

Annex B (normative): Locating beacon message bursts

B.1 Active mode

In active mode the locating beacon transmits messages in a burst of 8 messages once per minute. The SOTDMA communication state of Message 1 is used to pre-announce its future transmissions.

The locating beacon shall transmit Message 1 "Position report" with the Navigational Status set to 14 and Message 14 broadcast safety related message with the text "MOB ACTIVE". Message 14 shall be transmitted nominally every 4 minutes and replace one of the position reports on both channels.

The locating beacon transmissions shall alternate between AIS1 and AIS2.

The 1st and 5th burst shall be as follows;

- AIS1, Message 1, Nav Status = 14, comm-state (time-out={7,3}, sub-message=0)
- AIS2, Message 1, Nav Status = 14, comm-state (time-out={7,3}, sub-message=0)
- AIS1, Message 1, Nav Status = 14, comm-state (time-out={7,3}, sub-message=0)
- AIS2, Message 1, Nav Status = 14, comm-state (time-out={7,3}, sub-message=0)
- AIS1, Message 14 "MOB ACTIVE"
- AIS2, Message 14 "MOB ACTIVE"
- AIS1, Message 1, Nav Status = 14, comm-state (time-out={7,3}, sub-message=0)
- AIS2, Message 1, Nav Status = 14, comm-state (time-out={7,3}, sub-message=0)

The 2nd, 4th, 6th burst shall be as follows.

- AIS1, Message 1, Nav Status =14, comm-state (time-out={6,4,2}, sub-message=slot)
- AIS2, Message 1, Nav Status =14, comm-state (time-out={6,4,2}, sub-message=slot)
- AIS1, Message 1, Nav Status =14, comm-state (time-out={6,4,2}, sub-message=slot)
- AIS2, Message 1, Nav Status =14, comm-state (time-out={6,4,2}, sub-message=slot)
- AIS1, Message 1, Nav Status =14, comm-state (time-out={6,4,2}, sub-message=slot)
- AIS2, Message 1, Nav Status =14, comm-state (time-out={6,4,2}, sub-message=slot)
- AIS1, Message 1, Nav Status =14, comm-state (time-out={6,4,2}, sub-message=slot)
- AIS2, Message 1, Nav Status =14, comm-state (time-out={6,4,2}, sub-message=slot)

The 3rd burst shall be as follows.

- AIS1, Message 1, Nav Status = 14, comm-state (time-out=5, sub-message=0)
- AIS2, Message 1, Nav Status = 14, comm-state (time-out=5, sub-message=0)
- AIS1, Message 1, Nav Status = 14, comm-state (time-out=5, sub-message=0)
- AIS2, Message 1, Nav Status = 14, comm-state (time-out=5, sub-message=0)
- AIS1, Message 1, Nav Status = 14, comm-state (time-out=5, sub-message=0)

- AIS2, Message 1, Nav Status = 14, comm-state (time-out=5, sub-message=0)
- AIS1, Message 1, Nav Status = 14, comm-state (time-out=5, sub-message=0)
- AIS2, Message 1, Nav Status = 14, comm-state (time-out=5, sub-message=0)

The 7th burst shall be as follows.

- AIS1, Message 1, Nav Status = 14, comm-state (time-out=1, sub-message=utc)
- AIS2, Message 1, Nav Status = 14, comm-state (time-out=1, sub-message=utc)
- AIS1, Message 1, Nav Status = 14, comm-state (time-out=1, sub-message=utc)
- AIS2, Message 1, Nav Status = 14, comm-state (time-out=1, sub-message=utc)
- AIS1, Message 1, Nav Status = 14, comm-state (time-out=1, sub-message=utc)
- AIS2, Message 1, Nav Status = 14, comm-state (time-out=1, sub-message=utc)
- AIS1, Message 1, Nav Status = 14, comm-state (time-out=1, sub-message=utc)
- AIS2, Message 1, Nav Status = 14, comm-state (time-out=1, sub-message=utc)

The 8th burst shall be as follows.

- AIS1, Message 1, Nav Status = 14, comm-state (time-out=0, sub-message=incr)
- AIS2, Message 1, Nav Status = 14, comm-state (time-out=0, sub-message=incr)
- AIS1, Message 1, Nav Status = 14, comm-state (time-out=0, sub-message=incr)
- AIS2, Message 1, Nav Status = 14, comm-state (time-out=0, sub-message=incr)
- AIS1, Message 1, Nav Status = 14, comm-state (time-out=0, sub-message=incr)
- AIS2, Message 1, Nav Status = 14, comm-state (time-out=0, sub-message=incr)
- AIS1, Message 1, Nav Status = 14, comm-state (time-out=0, sub-message=incr)
- AIS2, Message 1, Nav Status = 14, comm-state (time-out=0, sub-message=incr)

In the 8th burst the increment to the next burst (sub-message=incr) shall be randomly selected between 2 025 and 2 475 slots.

This pattern of transmissions is repeated. It is permissible to start the sequence on AIS2.

Message 14 is transmitted at the 1st and 5th bursts (slot-time-out = 7 and 3) thereby ensuring that all future Message 14 messages are pre-announced.

B.2 Training mode

In Training mode the locating beacon transmits messages in a burst of 8 messages once per minute in exactly the same format as Active mode (B.1), except that:

- Message 1 Navigational Status is set to 15.
- Message 14 text string is replaced with "MOB TEST".

All other properties of Active mode are retained.

B.3 Test mode

When operating in the test mode there shall be one burst of 8 messages, 4 on each channel alternating:

- AIS1, Message 14 "MOB TEST"
- AIS2, Message 1, Nav Status = 15 not defined, comm-state (time-out=0, sub-message=0)
- AIS1, Message 1, Nav Status = 15 not defined, comm-state (time-out=0, sub-message=0)
- AIS2, Message 1, Nav Status = 15 not defined, comm-state (time-out=0, sub-message=0)
- AIS1, Message 1, Nav Status = 15 not defined, comm-state (time-out=0, sub-message=0)
- AIS2, Message 1, Nav Status = 15 not defined, comm-state (time-out=0, sub-message=0)
- AIS1, Message 1, Nav Status = 15 not defined, comm-state (time-out=0, sub-message=0)
- AIS2, Message 14 "MOB TEST"

It is permissible to start the sequence on AIS2.

B.4 Default message field values

On activation or if timed out in test mode, if the GNSS is unable to provide a valid position fix, then the reported position shall be longitude = 181° = not available = default and latitude = 91° = not available = default, COG = not available = default, SOG = not available = default, and the time stamp field shall be set to a value of 63.

If in active mode the GNSS is able to provide a valid position fix but that fix is subsequently lost, then the locating beacon shall continue to transmit with the last known position, COG and SOG. The time stamp field shall be set to a value of 62 "estimated position" and with the synchronization state set to 3.

History

Document history		
V1.1.0	May 2013	EN Approval Procedure AP 20130917: 2013-05-20 to 2013-09-17