

Draft **ETSI EN 303 098** V2.2.0 (2017-05)



**Maritime low power personal locating devices employing AIS;  
Harmonised Standard covering the essential requirements  
of article 3.2 of Directive 2014/53/EU**

---

Reference

REN/ERM-TG26-536

---

Keywords

harmonised standard, maritime, radio, SAR,  
testing

**ETSI**

650 Route des Lucioles  
F-06921 Sophia Antipolis Cedex - FRANCE

Tel.: +33 4 92 94 42 00 Fax: +33 4 93 65 47 16

Siret N° 348 623 562 00017 - NAF 742 C  
Association à but non lucratif enregistrée à la  
Sous-Préfecture de Grasse (06) N° 7803/88

---

**Important notice**

The present document can be downloaded from:

<http://www.etsi.org/standards-search>

The present document may be made available in electronic versions and/or in print. The content of any electronic and/or print versions of the present document shall not be modified without the prior written authorization of ETSI. In case of any existing or perceived difference in contents between such versions and/or in print, the only prevailing document is the print of the Portable Document Format (PDF) version kept on a specific network drive within ETSI Secretariat.

Users of the present document should be aware that the document may be subject to revision or change of status. Information on the current status of this and other ETSI documents is available at

<https://portal.etsi.org/TB/ETSIDeliverableStatus.aspx>

If you find errors in the present document, please send your comment to one of the following services:

<https://portal.etsi.org/People/CommiteeSupportStaff.aspx>

---

**Copyright Notification**

No part may be reproduced or utilized in any form or by any means, electronic or mechanical, including photocopying and microfilm except as authorized by written permission of ETSI.

The content of the PDF version shall not be modified without the written authorization of ETSI.

The copyright and the foregoing restriction extend to reproduction in all media.

© European Telecommunications Standards Institute 2017.

All rights reserved.

DECT™, PLUGTESTS™, UMTS™ and the ETSI logo are Trade Marks of ETSI registered for the benefit of its Members.

3GPP™ and LTE™ are Trade Marks of ETSI registered for the benefit of its Members and of the 3GPP Organizational Partners.

oneM2M logo is protected for the benefit of its Members

GSM® and the GSM logo are Trade Marks registered and owned by the GSM Association.

# Contents

Intellectual Property Rights .....	7
Foreword.....	7
Modal verbs terminology.....	7
1 Scope .....	8
2 References .....	8
2.1 Normative references .....	8
2.2 Informative references.....	9
3 Definitions, symbols and abbreviations .....	9
3.1 Definitions.....	9
3.2 Symbols.....	9
3.3 Abbreviations .....	10
4 General requirements .....	10
4.1 Construction .....	10
4.1.0 General.....	10
4.1.1 Categories of equipment .....	11
4.2 Controls.....	11
4.3 Indicators.....	11
4.4 Identifier (user ID).....	12
4.5 Labelling.....	12
4.6 Instructions.....	12
4.7 Power source .....	12
4.7.1 Battery requirements .....	12
4.7.2 Battery capacity .....	13
4.7.3 Safety precautions.....	13
5 Technical requirements .....	13
5.1 General .....	13
5.2 AIS transmission characteristics.....	14
5.2.0 General.....	14
5.2.1 AIS messages.....	14
5.2.1.0 General.....	14
5.2.1.1 Active mode .....	14
5.2.1.2 Test mode.....	14
5.2.2 Synchronization .....	14
5.2.2.0 General .....	14
5.2.2.1 Active mode .....	14
5.2.2.2 Test mode.....	15
5.2.3 GNSS position source.....	15
5.2.3.0 General .....	15
5.2.3.1 UTC.....	15
5.2.3.2 UTC parameters storage.....	15
5.2.4 Required settings .....	15
5.2.5 Minimum transmitter performance characteristics .....	16
5.2.6 VHF Data Link (VDL) Access .....	17
5.2.6.0 General .....	17
5.2.6.1 Active mode .....	17
5.2.6.2 Test mode.....	17
6 General conditions of measurement .....	17
6.1 Conformity testing.....	17
6.2 Test Frequencies.....	18
6.3 Identifier (user ID).....	18
6.4 Artificial Antenna.....	18
6.5 Test signals.....	18
6.5.0 General.....	18

6.5.1	Standard test signal number 1 .....	18
6.5.2	Standard test signal number 2 .....	18
6.5.3	Standard test signal number 3 .....	18
6.5.4	Reference timing signal .....	18
6.6	Test conditions power sources and ambient temperatures .....	19
6.6.1	Normal and extreme test conditions .....	19
6.6.2	Test power source .....	19
6.7	Normal test conditions .....	19
6.7.1	Normal temperature and humidity .....	19
6.7.2	Normal test voltage .....	19
6.8	Extreme test conditions .....	19
6.8.1	Extreme temperatures .....	19
6.8.2	Extreme test voltages .....	19
6.8.2.1	Upper extreme test voltage .....	19
6.8.2.2	Lower extreme test voltage .....	20
7	Environmental tests .....	20
7.1	Introduction .....	20
7.2	Procedure .....	20
7.3	Performance check .....	20
7.4	Drop test .....	20
7.4.1	Definition .....	20
7.4.2	Test conditions .....	20
7.4.3	Method of measurement .....	21
7.4.4	Requirements .....	21
7.5	Temperature tests .....	21
7.5.1	Definition .....	21
7.5.2	Dry heat test .....	21
7.5.2.1	Method of measurement .....	21
7.5.2.2	Requirements .....	21
7.5.3	Damp heat test .....	22
7.5.3.1	Method of measurement .....	22
7.5.3.2	Requirements .....	22
7.5.4	Low temperature test .....	22
7.5.4.1	Method of measurement .....	22
7.5.4.2	Requirements .....	22
7.5.5	Low temperature battery endurance test .....	22
7.5.5.1	Method of measurement .....	22
7.5.5.2	Requirements .....	23
7.6	Vibration test .....	23
7.6.1	Definition .....	23
7.6.2	Method of measurement .....	23
7.6.3	Requirement .....	23
7.7	Corrosion test .....	24
7.7.1	Definition .....	24
7.7.2	Method of measurement .....	24
7.7.3	Requirements .....	24
7.8	Thermal shock test .....	25
7.8.1	Definition .....	25
7.8.2	Method of measurement .....	25
7.8.3	Requirements .....	25
7.9	Buoyancy test .....	25
7.9.1	Definition .....	25
7.9.2	Method of measurement .....	25
7.9.3	Requirements .....	25
7.10	Compass safe distance test .....	26
7.10.1	Definition .....	26
7.10.2	Method of measurement .....	26
7.10.3	Requirements .....	26
7.11	Solar radiation test .....	27
7.11.0	Applicability .....	27
7.11.1	Definition .....	27

7.11.2	Method of measurement .....	27
7.11.3	Requirements .....	27
7.12	Oil resistance test.....	27
7.12.0	Applicability .....	27
7.12.1	Definition.....	27
7.12.2	Method of measurement .....	27
7.12.3	Requirements .....	28
7.13	Protection of the transmitter .....	28
7.13.1	Definition.....	28
7.13.2	Method of measurement .....	28
7.13.3	Requirement.....	28
8	Tests on the AIS transmitter .....	28
8.1	Frequency error .....	28
8.1.1	Definition.....	28
8.1.2	Method of measurement .....	29
8.1.3	Limit .....	29
8.2	Conducted Power .....	29
8.2.0	Purpose .....	29
8.2.1	Definition.....	29
8.2.2	Method of measurement under normal test conditions .....	29
8.2.3	Limit .....	29
8.3	Maximum Effective Radiated Power (ERP).....	29
8.3.1	Definition.....	29
8.3.2	Method of measurement .....	30
8.3.3	Limits.....	30
8.4	Transmitter spectrum mask .....	30
8.4.1	Definition.....	30
8.4.2	Method of measurement .....	30
8.4.3	Limit .....	31
8.5	Transmitter transient behaviour (output power).....	31
8.5.1	Definition.....	31
8.5.2	Method of measurement .....	32
8.5.3	Limit .....	33
8.6	Transmitter Transient Behaviour (frequency deviation) .....	33
8.6.1	Definition.....	33
8.6.2	Method of measurement .....	33
8.6.3	Limit .....	34
8.7	Synchronization accuracy.....	34
8.7.1	Definition.....	34
8.7.2	Method of measurement .....	34
8.7.3	Limit .....	35
8.8	Spurious emissions .....	36
8.8.1	Definition.....	36
8.8.2	Method of measurement .....	36
8.8.3	Limit .....	36
9	VDL Link layer tests .....	36
9.1	Active mode tests .....	36
9.1.0	Precaution .....	36
9.1.1	Method of measurement .....	36
9.1.2	Initialization period - Required results.....	37
9.1.3	Message content of Message 1 - Required results .....	37
9.1.4	Message content of Message 14 - Required results .....	37
9.1.5	Transmission schedule for Message 1 - Required results .....	37
9.1.6	Communication state of Message 1 - Required results .....	38
9.1.7	Transmission schedule of Message 14 - Required results.....	38
9.1.8	Transmission with lost GNSS - Required results.....	38
9.2	Test mode tests with GNSS data available .....	39
9.2.1	Method of measurement .....	39
9.2.2	Required results .....	39
9.3	Test mode tests without GNSS data available.....	39

9.3.1	Method of measurement .....	39
9.3.2	Required results .....	39
10	Testing for compliance with technical requirements.....	40
10.1	Environmental conditions for testing .....	40
10.2	Interpretation of the measurement results .....	40
<b>Annex A (informative):</b>	<b>Relationship between the present document and the essential requirements of Directive 2014/53/EU .....</b>	<b>41</b>
<b>Annex B (normative):</b>	<b>Locating device message bursts .....</b>	<b>42</b>
B.1	Active mode .....	42
B.2	Test mode .....	43
B.3	Default message field values.....	44
<b>Annex C (normative):</b>	<b>Additional Test Supports .....</b>	<b>45</b>
C.1	Float-free support .....	45
<b>Annex D (informative):</b>	<b>Bibliography .....</b>	<b>46</b>
<b>Annex E (informative):</b>	<b>Change history .....</b>	<b>47</b>
History .....		48

---

## Intellectual Property Rights

IPRs essential or potentially essential to the present document may have been declared to ETSI. The information pertaining to these essential IPRs, if any, is publicly available for **ETSI members and non-members**, and can be found in ETSI SR 000 314: "*Intellectual Property Rights (IPRs); Essential, or potentially Essential, IPRs notified to ETSI in respect of ETSI standards*", which is available from the ETSI Secretariat. Latest updates are available on the ETSI Web server (<https://ipr.etsi.org>).

Pursuant to the ETSI IPR Policy, no investigation, including IPR searches, has been carried out by ETSI. No guarantee can be given as to the existence of other IPRs not referenced in ETSI SR 000 314 (or the updates on the ETSI Web server) which are, or may be, or may become, essential to the present document.

---

## Foreword

This draft Harmonised European Standard (EN) has been produced by ETSI Technical Committee Electromagnetic compatibility and Radio spectrum Matters (ERM), and is now submitted for the combined Public Enquiry and Vote phase of the ETSI standards EN Approval Procedure.

The present document has been prepared under the Commission's standardisation request C(2015) 5376 final [i.5] to provide one voluntary means of conforming to the essential requirements of Directive 2014/53/EU on the harmonisation of the laws of the Member States relating to the making available on the market of radio equipment and repealing Directive 1999/5/EC [i.1].

Once the present document is cited in the Official Journal of the European Union under that Directive, compliance with the normative clauses of the present document given in table A.1 confers, within the limits of the scope of the present document, a presumption of conformity with the corresponding essential requirements of that Directive and associated EFTA regulations.

<b>Proposed national transposition dates</b>	
Date of latest announcement of this EN (doa):	3 months after ETSI publication
Date of latest publication of new National Standard or endorsement of this EN (dop/e):	6 months after doa
Date of withdrawal of any conflicting National Standard (dow):	6 months after doa

---

## Modal verbs terminology

In the present document "**shall**", "**shall not**", "**should**", "**should not**", "**may**", "**need not**", "**will**", "**will not**", "**can**" and "**cannot**" are to be interpreted as described in clause 3.2 of the [ETSI Drafting Rules](#) (Verbal forms for the expression of provisions).

"**must**" and "**must not**" are **NOT** allowed in ETSI deliverables except when used in direct citation.

---

# 1 Scope

The present document specifies technical characteristics and methods of measurements for low power maritime personal locating devices employing AIS.

The present document does not cover requirements for the integrated GNSS receiver providing locating function.

The present document incorporates the relevant provisions of the International Telecommunication Union (ITU) radio regulations [i.4] included in Recommendation ITU-R M.1371-5 [1].

For this application, both the radiated power and the length of time of operation are limited to enable the equipment to be sufficiently small and light to be worn comfortably at all times and to limit the operating range to a local area.

The present document covers the essential requirements of article 3.2 of Directive 2014/53/EU under the conditions identified in annex A.

---

## 2 References

### 2.1 Normative references

References are specific, identified by date of publication and/or edition number or version number. Only the cited version applies.

Referenced documents which are not found to be publicly available in the expected location might be found at <https://docbox.etsi.org/Reference/>.

NOTE: While any hyperlinks included in this clause were valid at the time of publication, ETSI cannot guarantee their long term validity.

The following referenced documents are necessary for the application of the present document.

- [1] Recommendation ITU-R M.1371-5 (02/2014): "Technical characteristics for an automatic identification system using time-division multiple access in the VHF maritime mobile band".
- [2] CENELEC EN 61108-1 (2003): "Maritime navigation and radiocommunication equipment and systems - Global navigation satellite systems (GNSS) - Part 1: Global positioning system (GPS) - Receiver equipment - Performance standards, methods of testing and required test results".
- [3] CENELEC EN 61108-2 (1998): "Maritime navigation and radiocommunication equipment and systems - Global navigation satellite systems (GNSS) - Part 2: Global navigation satellite system (GLONASS) - Receiver equipment - Performance standards, methods of testing and required test results".
- [4] CENELEC EN 61108-3 (2010): "Maritime navigation and radiocommunication equipment and systems - Global navigation satellite systems (GNSS) - Part 3: Galileo receiver equipment - Performance requirements, methods of testing and required test results".
- [5] Recommendation ITU-T O.153 (10/1992): "Basic parameters for the measurement of error performance at bit rates below the primary rate".
- [6] IMO Annex 11 - Resolution MSC.149(77) - (adopted on 3 June 2003): "Adoption of the revised performance standards for survival craft portable two-way VHF radiotelephone apparatus".
- [7] ETSI TS 103 052 (V1.1.1) (03-2011): "Electromagnetic compatibility and Radio spectrum Matters (ERM); Radiated measurement methods and general arrangements for test sites up to 100 GHz".



## 2.2 Informative references

References are either specific (identified by date of publication and/or edition number or version number) or non-specific. For specific references, only the cited version applies. For non-specific references, the latest version of the referenced document (including any amendments) applies.

NOTE: While any hyperlinks included in this clause were valid at the time of publication, ETSI cannot guarantee their long term validity.

The following referenced documents are not necessary for the application of the present document but they assist the user with regard to a particular subject area.

- [i.1] Directive 2014/53/EU of the European Parliament and of the Council of 16 April 2014 on the harmonisation of the laws of the Member States relating to the making available on the market of radio equipment and repealing Directive 1999/5/EC.
- [i.2] ETSI TR 100 028-1 (V1.4.1) (12-2001): "Electromagnetic compatibility and Radio spectrum Matters (ERM); Uncertainties in the measurement of mobile radio equipment characteristics; Part 1".
- [i.3] ETSI TR 100 028-2 (V1.4.1) (12-2001): "Electromagnetic compatibility and Radio spectrum Matters (ERM); Uncertainties in the measurement of mobile radio equipment characteristics; Part 2".
- [i.4] ITU-R Radio Regulations 2016.
- [i.5] Commission Implementing Decision C(2015) 5376 final of 4.8.2015 on a standardisation request to the European Committee for Electrotechnical Standardisation and to the European Telecommunications Standards Institute as regards radio equipment in support of Directive 2014/53/EU of the European Parliament and of the Council.

---

## 3 Definitions, symbols and abbreviations

### 3.1 Definitions

For the purposes of the present document the following terms and definitions apply:

**active mode:** activated mode, transmitting in an emergency situation

**dedicated antenna:** removable antenna supplied and tested with the equipment, designed as an indispensable part of the equipment

**integral antenna:** antenna designed to be connected to the equipment without the use of a 50  $\Omega$  external connector and considered to be part of the equipment

NOTE: An integral antenna may be fitted internally or externally to the equipment.

**test mode:** self testing mode, not involved in a genuine emergency

**UTC lock:** GNSS has precisely locked to UTC so that it can determine SOTDMA slot timing correctly.

**UTC parameters:** "Coordinated Universal Time (UTC) offset parameters" GNSS data that contains leap second offset information

### 3.2 Symbols

For the purposes of the present document, the following symbols apply:

cSt	centi-Stokes
dB	decibel
$\mu$ T	microtesla

### 3.3 Abbreviations

For the purposes of the present document, the following abbreviations apply:

AIS	Automatic Identification System
ASTM	American Society for Testing and Materials
CIRM	Comité International Radio-Maritime
COG	Course Over Ground
CRC	Cyclic Redundancy Check
CW	Continuous Wave
EFTA	European Free Trade Area
EIRP	Effective Isotropic Radiated Power
ERP	Effective Radiated Power
EUT	Equipment Under Test
GLONASS	GLObal NAVigation Satellite System (Russian system)
GMSK	Gaussian Minimum Shift Keying
GNSS	Global Navigation Satellite System
GPS	Global Positioning System
GTRF	Galileo Terrestrial Reference Frame system
IMO	International Maritime Organization
ISO	International Organization for Standardization
ITRF	International Terrestrial Reference Frame
ITU-R	International Telecommunication Union Radiocommunication sector
ITU-T	International Telecommunication Union Telecommunication sector
MOB	Man Over-Board
NRZI	Non Return to Zero, Inverted
PPS	Pulses Per Second
PZ-90	Parametry Zemli 1990
RAIM	Receiver Autonomous Integrity Monitoring
RF	Radio Frequency
SOG	Speed Over Ground
SOTDMA	Self-Organized Time Division Multiple Access
TDMA	Time Division Multiple Access
UTC	Coordinated Universal Time
VDL	VHF Data Link
VHF	Very High Frequency
VSWR	Voltage Standing Wave Ratio
WGS-84	World Geodetic System 1984

---

## 4 General requirements

### 4.1 Construction

#### 4.1.0 General

The manufacturer shall provide evidence that all requirements in clause 4 are fulfilled.

In all respects, the mechanical and electrical design and the construction and finish of the equipment shall conform with good engineering practice.

The equipment shall be designed to minimize the risk of internal and external damage during use or stowage.

The exterior of the equipment shall have no sharp edges or projections that could easily damage inflatable rafts or injure personnel.

The general construction and method of operation shall provide a high degree of proof against inadvertent operation due to magnetic influences, handling, stowage and transit, whilst still providing a simple means of operation in an emergency.

The equipment shall be portable, lightweight, compact and be designed as one integral unit. The locating device shall derive its energy from a battery forming a part of the equipment and incorporate an integral or dedicated antenna which may be either fixed length or extendible.

The locating device may be fitted with a test facility by which the functioning of the transmitter and battery can be easily tested without the use of any external equipment.

The equipment shall be capable of being used by an unskilled person.

The locating device shall be watertight to a depth of 1 m (see clause 7.13).

The equipment shall not be unduly affected by sea water or oil and shall be resistant to deterioration by prolonged exposure to sunlight.

A substantial part of the equipment shall be of highly visible yellow or orange colour to assist visual location.

### 4.1.1 Categories of equipment

Two categories are defined:

- Category 1 locating devices shall have sufficient positive buoyancy to float in fresh water.
- Category 2 locating devices intended to be incorporated into or attached to a buoyancy aid are not required to float.

Category 1 locating devices that can float free may have a lanyard to attach them to a person or life vest. Where a lanyard is employed it shall meet the requirements of IMO MSC.149(77) [6], paragraph 2.3.11. The user manual or instructions shall include necessary information to allow the user to properly attach the locating device lanyard.

The user manual or instructions for Category 2 devices shall include necessary information to allow the user to fit or attach the locating device to a buoyancy aid.

## 4.2 Controls

The equipment shall be initially activated by the use of two simple, but independent mechanical actions, neither of which on its own shall activate the equipment. The second mechanical action may be replaced by an immersion sensor. Where the second action is replaced by an immersion sensor then the first action shall be an arm function thus to ensure the device is armed for automatic activation when submerged.

It shall only be possible to activate the equipment after a seal or other mechanical restraint has been removed from the first mechanical action. For devices without an arm function it shall not be possible to reattach a removed seal or restraint. After activation it shall be simple to de-activate the equipment and the means to deactivate the equipment shall be clearly marked.

The switch that operates any test facility (clause 4.1) shall be so designed that it returns automatically to the off-position when released.

## 4.3 Indicators

The equipment shall be provided with a visual and/or audible indication that signals are being emitted. The indicator shall be sufficiently bright to be seen in bright sunlight. Except when operating in test mode the indicator shall not be green in colour.

The indicator shall clearly distinguish the following states:

- i) The locating device has been activated and is waiting for GNSS data.
- ii) The locating device has GNSS data and is transmitting in active mode.
- iii) The locating device is undergoing test and is transmitting in test mode.
- iv) The locating device has completed a test or has been de-activated.

## 4.4 Identifier (user ID)

The locating device shall have an identifier to distinguish it from other AIS devices.

The User ID for a personal search and rescue locating device is 972xxyyyy, where xx = manufacturer ID 01 to 99; yyyy = the sequence number 0000 to 9999. Manufacturers IDs are issued by CIRM. Manufacturers shall only use manufacturer IDs that have been issued to them by CIRM, except for testing purposes where the ID xx=00 can be used (see clause 6.3).

After being programmed by the manufacturer, it shall not be possible for the user to change the identifier of the locating device.

The user ID shall be held in non-volatile memory.

## 4.5 Labelling

The equipment shall be provided with a label, or labels, permanently affixed to the exterior of the equipment, containing the information described hereunder:

- user ID of the equipment (see clause 4.4) and manufacturer serial number;
- type designation of the equipment with prefix AIS-MOB;
- adequate instructions to enable the equipment to be activated and de-activated;
- the type of battery as specified by the manufacturer of the locating device;
- a warning to not block the GNSS antenna;
- the compass safe distance as measured in clause 7.10;
- a warning to the effect that the locating device should not be operated except in an emergency;
- the date on which the battery will need to be replaced. Simple means shall be provided for changing this date when the battery is replaced. The battery replacement date marked on the locating device should be the date specified in clause 4.7.1.

## 4.6 Instructions

Necessary operating instructions shall be provided with the equipment. These should include the following warnings:

- "WARNING - An AIS-MOB Man overboard device is only intended for short range signalling to an AIS receiver installed onboard your own vessel. It will not directly alert the emergency services or other vessels."
- "WARNING - This equipment is not intended for routine tracking of persons or property. This includes tracking of divers."
- "WARNING - If self-test is performed more frequently than once a month, then battery life may be reduced."

## 4.7 Power source

### 4.7.1 Battery requirements

The type of battery and designation specified by the manufacturer for use in the equipment shall be clearly and indelibly marked on the equipment.

The manufacturer should establish a useful life and an expiry date for primary (non-rechargeable) batteries. The useful life is the period of time after the date of battery manufacture that the battery will continue to meet the input power requirements of the locating device, over the entire specified operating temperature range. The following losses shall be included (at a temperature of  $+20\text{ °C} \pm 5\text{ °C}$ ):

- a) self-testing monthly with GNSS data available;
- b) self-discharge of the battery;
- c) stand-by loads.

The expiry date of the battery shall be the battery installation date plus no more than half the useful life of the battery. The battery shall have a minimum useful life of at least two years. The installation date shall be no more than one year from the date of manufacture of the battery. The battery shall be clearly and durably marked with its date of manufacture. The locating device shall be clearly marked with the expiry date of the battery.

## 4.7.2 Battery capacity

The battery, after having met the requirements of clause 4.7.1 shall have sufficient remaining capacity to power an activated locating device and keep it transmitting for at least 12 hours at a temperature of  $-20\text{ °C} \pm 3\text{ °C}$ .

## 4.7.3 Safety precautions

Provisions shall be made for protecting the equipment from damage due to the accidental reversal of polarity of the battery.

# 5 Technical requirements

## 5.1 General

When activated the locating device shall be capable of transmitting messages that indicate the position of a person in the water. The transmitted messages shall be compatible with existing AIS installations. The transmitted messages shall be recognized and displayed by AIS receivers in the reception range of the transmitter, and clearly distinguish the transmitter as a personal Man Over-Board (MOB) locating device. AIS TDMA Synchronization shall be UTC direct; the locating device does not require an AIS receiver.

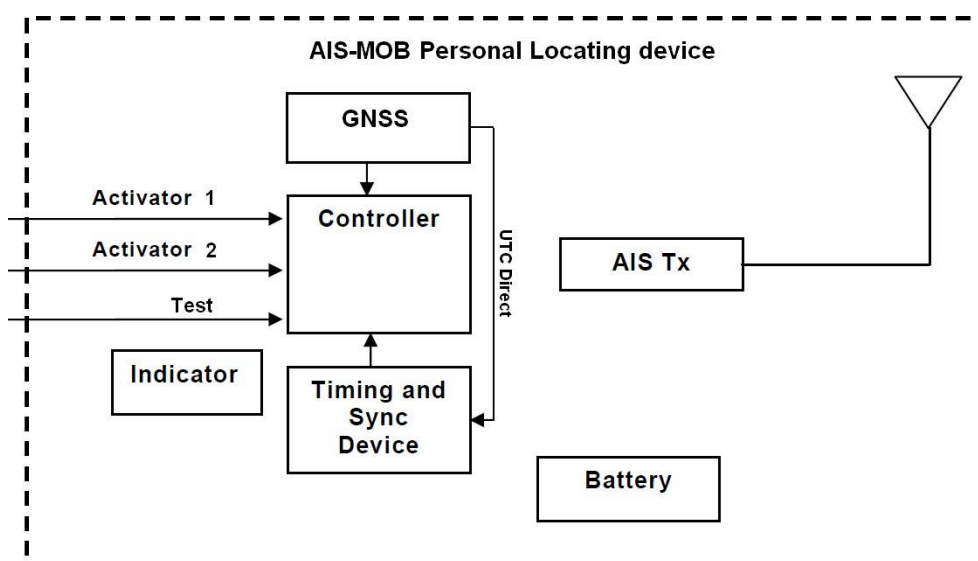

Figure 1: Functional block diagram of personal locating device

## 5.2 AIS transmission characteristics

### 5.2.0 General

The AIS Tx transmits using modified SOTDMA on two channels AIS1 and AIS2. The GNSS receiver, e.g. a GPS receiver, determines the current position of the locating device and facilitates TDMA synchronization in the UTC direct mode.

The locating device shall shutdown automatically if, under a fault condition, the transmitter remains permanently keyed for more than 2 seconds. This shutdown shall be independent of the operating software.

### 5.2.1 AIS messages

#### 5.2.1.0 General

The locating device shall broadcast Message 1 and Message 14, as defined in Recommendation ITU-R M.1371-5 [1]. The content of the messages differs for active transmissions (active mode) and test transmissions (test mode). The combination of these messages in burst sequences is detailed in annex B.

#### 5.2.1.1 Active mode

For Message 1 the Navigational status shall be set to "14". For message 14 the safety related text shall be set to "MOB ACTIVE" (see clause B.1 for details).

#### 5.2.1.2 Test mode

For Message 1 the Navigational status shall be set to "15". For message 14 the safety related text shall be set to "MOB TEST" (see clause B.2 for details).

### 5.2.2 Synchronization

#### 5.2.2.0 General

In UTC direct mode the locating device determines slot timing using the UTC timing signal from the GNSS.

The TDMA timing error shall be less than  $\pm 312 \mu\text{s}$ .

The position of the locating device shall be determined at least every minute once a GNSS position fix has been obtained.

#### 5.2.2.1 Active mode

The locating device shall start transmitting as soon as a position fix, SOG, COG and UTC lock are available or 60 seconds after activation if not. Optionally the locating device may also transmit unsynchronized using default settings (see clause B.3 for details), within a period from 10 to 30 seconds after activation. This initial transmission is intended to inform the local vessel that an MOB incident has occurred and allow the position of the vessel to be recorded at that time.

NOTE: In the present document, the terms "UTC lock" and "position fix" are used independently. It is however recognized that in practice it is unlikely that a position fix can be obtained without UTC lock and vice-versa.

The locating device shall begin synchronized transmission with the correct GNSS position within 5 minutes under normal operating conditions.

The locating device shall continue transmission even if the position and UTC lock from the positioning system is subsequently lost or fails. The locating device shall maintain, as best it can, proper timing internally if UTC lock is lost. If a position fix is lost, the locating device shall continue to transmit with the last known good position (see clause B.3).

### 5.2.2.2 Test mode

A single test message burst (see clause B.2) shall be transmitted as soon as a position fix, SOG, COG and time are available. The device shall transmit when UTC lock is available so that SOTDMA is properly synchronized even if the UTC parameters are invalid or out of date. If UTC lock is not available after five minutes the device shall abandon the test mode without transmitting.

Activation of the test facility shall reset automatically after transmission of the burst.

## 5.2.3 GNSS position source

### 5.2.3.0 General

The GNSS compliant receiver shall meet the following requirements of CENELEC EN 61108 series (GPS [2], GLONASS [3] or Galileo [4]): position accuracy, acquisition, re-acquisition, receiver sensitivity, RF dynamic range, position update, effects of specific interference signals but with a minimum update rate of once per minute, provide a resolution of one ten thousandth of a minute of arc and uses the WGS-84 datum.

NOTE: Galileo uses Galileo Terrestrial Reference Frame System (GTRF) datum which is a realization of the International Terrestrial Reference Frame (ITRF) system and differs from WGS-84 by less than 5 cm worldwide. GLONASS uses the Parametry Zemli 1990 (PZ-90) datum. As of September 17, 2007 the PZ-90 datum has been updated to differ from WGS-84 by less than 40 cm worldwide.

The manufacturer shall provide evidence that an internal GNSS device could start is forced at every AIS-MOB activation (cold start refers to the absence of time dependent or position dependent data in memory, which might affect the acquisition of the GNSS position).

### 5.2.3.1 UTC

All AIS equipment uses UTC for synchronizing transmissions. The version of UTC transmitted by both GPS and Galileo, is not perturbed by leap seconds so that GPS time as of January 2013 is ahead of UTC by 16 seconds. The version of UTC transmitted by GLONASS does apply leap seconds and remains synchronized to UTC albeit offset by 3 hours. Both GPS and Galileo transmit the timing offset that is applied by the GNSS receiver when computing UTC. AIS SOTDMA relies on the correct and timely computation of UTC to determine slot timings accurately. Since the AIS slot structure repeats every two seconds, the incorrect application of a leap second when determining UTC will result in AIS transmissions beginning in the middle of a time slot rather than at the beginning of the time slot. Care shall be taken when designing with multi-system GNSS receivers that UTC is correctly determined across satellite systems.

Since the equipment is required to do a GNSS cold start and to transmit its first valid position within 5 minutes of activation for GPS and Galileo GNSS receivers the equipment may maintain a stored copy of the UTC parameters leap second information.

### 5.2.3.2 UTC parameters storage

Where manufacturers do provide a mechanism whereby the stored copy of the UTC parameters (that is leap second offset and predictions) can be kept up to date, then the GNSS cold start shall not make use of any stored information other than valid leap second information.

## 5.2.4 Required settings

The locating device shall operate on dual channels, AIS1 and AIS2, in the VHF Maritime Mobile Service band. Tables 1, 2 and 3 are derived from Recommendation ITU-R M.1371-5 [1] and give the parameters required for an AIS locating device.

**Table 1: Required parameter settings**

Symbol	Parameter name	Setting
PH.AIS1	Channel 1 (default channel 1)	161,975 MHz
PH.AIS2	Channel 2 (default channel 2)	162,025 MHz
PH.BR	Bit rate	9 600 bps
PH.TS	Training sequence	24 bits
PH.TST	Transmitter settling time (Transmit power within 20 % of final value. Frequency stable to within $\pm 1,0$ kHz of final value). Tested at manufacturers declared transmit power.	$\leq 1,0$ ms
	Ramp down time	$\leq 832$ $\mu$ s
	Transmission duration	$\leq 26,6$ ms
	Transmitter output power	600 mW ERP
NOTE:	Radiated power in the present document is measured in ERP by dipole substitution. Recommendation ITU-R M.1371-5 [1] gives transmitter power in EIRP. A conversion factor of 2,15 dB has been applied so that 1 W EIRP is approximately 600 mW ERP.	

**Table 2: Required settings of physical layer constants**

Symbol	Parameter name	Value
PH.DE	Data encoding	NRZI
PH.FEC	Forward error correction	Not used
PH.IL	Interleaving	Not used
PH.BS	Bit scrambling	Not used
PH.MOD	Modulation	Bandwidth adapted GMSK

**Table 3: Modulation parameters of the physical layer**

Symbol	Name	Value
PH.TXBT	Transmit BT-product	0,4
PH.MI	Modulation index	0,5

## 5.2.5 Minimum transmitter performance characteristics

The technical characteristics as specified in table 4 shall apply to the transmitter.

**Table 4: Minimum required transmitter characteristics**

Transmitter parameters	Requirements
Carrier power	nominal radiated power 600 mW ERP
Carrier frequency error	$\pm 500$ Hz (normal), $\pm 1\ 000$ Hz (extreme)
Slotted modulation mask	-20 dBc $\Delta f_c > \pm 10$ kHz -40 dBc $\pm 25$ kHz $< \Delta f_c < \pm 62,5$ kHz see figure 4 in clause 8.4
Transmitter test sequence and modulation Accuracy	$< 3\ 400$ Hz for Bit 0, 1 (normal and extreme) $2\ 400$ Hz $\pm 480$ Hz for Bit 2, 3 (normal and extreme) $2\ 400$ Hz $\pm 240$ Hz for Bit 4 ... 31 (normal, $2\ 400$ Hz + 480 Hz extreme) For Bits Bit 32 ... 199 $1\ 740$ Hz $\pm 175$ Hz (normal, $1\ 740$ Hz + 350 Hz extreme) for a bit pattern of 0101 $2\ 400$ Hz $\pm 240$ Hz (normal, $2\ 400$ Hz + 350 Hz extreme) for a bit pattern of 00001111
Transmitter output power versus time	Power within mask shown in figure 5 and timings given in table 7 in clause 8.5
Spurious emissions	maximum 25 $\mu$ W between 108 MHz to 137 MHz, 156 MHz to 161,5 MHz, and 1 525 MHz to 1 610 MHz



## 5.2.6 VHF Data Link (VDL) Access

### 5.2.6.0 General

The locating device shall use modified SOTDMA for the transmission of message bursts (annex B).

The locating device shall determine its own schedule for transmission of its messages based on random selection of the first slot of the first burst. The other 7 slots within the first burst shall be fixed with reference to the first slot of the burst. The increment between transmission slots within a burst shall be 75 slots and the transmissions shall alternate between channels AIS1 and AIS2.

#### 5.2.6.1 Active mode

In active mode (see figure 2), the locating device shall set a slot-time-out = 7 in the Communication state of all Message 1 transmissions in the first burst, and thereafter the slot time-out shall be decreased according to the rules of SOTDMA in Recommendation ITU-R M.1371-5 [1]. Since the locating device does not have an AIS receiver, all slots shall be regarded as candidates in the selection process. When time out occurs, the offset to the next set of 8 bursts is randomly selected at 1 minute  $\pm$  6 s.

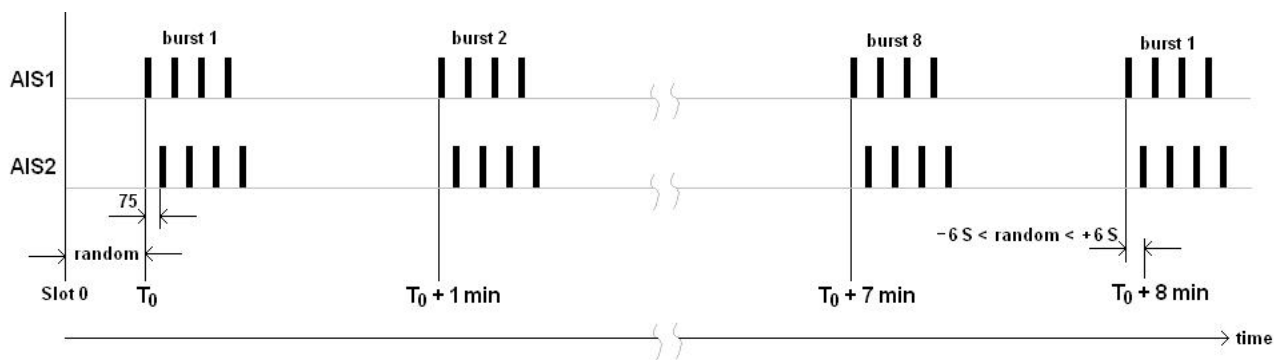

**Figure 2: Burst transmissions in active mode**

All slot-time-out values of the Communication state of all Message 1 transmissions within every burst shall be the same.

Two Message 14 shall be transmitted every 4<sup>th</sup> minute one on each channel, starting in the first minute (i.e. slot-time-out = 7 and 3), and shall be the 5<sup>th</sup> and 6<sup>th</sup> message in the burst (see clause B.1).

Message 14 shall be transmitted alternately on AIS1 and AIS2.

#### 5.2.6.2 Test mode

In test mode the locating device shall set a slot-time-out = 0 and sub-message = 0 in the Communication state of all Message 1 transmissions in the first and only burst.

All slot time-out values of the Communication state of all Message 1 transmissions within every burst shall be the same.

Two Message 14 shall be transmitted one on each channel, and shall be the 1<sup>st</sup> and 8<sup>th</sup> message in the burst (see clause B.2).

## 6 General conditions of measurement

### 6.1 Conformity testing

For the purpose of conformity testing clauses 6.2 to 6.5 shall apply.

## 6.2 Test Frequencies

Where radiated measurements are not performed in an anechoic chamber alternative channels other than the default channels for AIS1 and AIS2 may be used during testing to avoid interference with live maritime systems. Where alternative channels are used the alternative channels used shall be of the same separation (50 KHz apart) and within  $\pm 1\%$  of 162 MHz.

## 6.3 Identifier (user ID)

The manufacturer ID  $xx = 00$  is reserved for testing purposes. The identifier used during testing to the present document shall be in the format 97200yyyy.

## 6.4 Artificial Antenna

Where applicable, tests shall be carried out using an artificial antenna which shall be a substantially non-reactive non-radiating load connected to the antenna connector. The Voltage Standing Wave Ratio (VSWR) at the 50  $\Omega$  connector or the provider's specified test fixture shall not be greater than 1,5:1 over the frequency range of the measurement.

In the case of integral antenna equipment, if the equipment does not have an internal permanent 50  $\Omega$  connector then it is permitted to supply a second sample of the equipment with a temporary 50  $\Omega$  antenna cable and connector fitted to facilitate testing.

## 6.5 Test signals

### 6.5.0 General

The manufacturer shall supply with the submitted samples a method for producing the following test transmission signals. In addition, for some tests, it shall be possible to operate the samples in a continuous unmodulated transmission (CW) mode.

NOTE: Transmitters may have limitations concerning their maximum continuous transmit time and/or their transmission duty cycle. It is intended that such limitations are respected during testing.

### 6.5.1 Standard test signal number 1

A series of reversals 010101... transmitted as all the bits within an AIS message frame, including header, start flag, end flag and CRC. NRZI is not applied to the reversals or CRC (Cyclic Redundancy Check), i.e. unaltered "On Air" data. The RF should be ramped up and down on either end of the AIS message frame.

### 6.5.2 Standard test signal number 2

A series of 00001111... repeated as the data within an AIS message frame, including header, start flag, end flag and CRC. NRZI is not applied to the data or CRC. The RF should be ramped up and down on either end of the AIS message frame.

### 6.5.3 Standard test signal number 3

A 511-bit pseudo random sequence as specified in Recommendation ITU-T O.153 [5] shall be used as the data within an AIS message frame with header, start flag, end flag and CRC. NRZI is not applied to the pseudo random sequence or CRC. The RF should be ramped up and down on either end of the AIS message frame.

### 6.5.4 Reference timing signal

For the timing tests in clauses 8.5, 8.6 and 8.7 the manufacturer shall supply a sample that produces an edge trigger timing signal corresponding to  $T_0$  in figure 5 of clause 8.5.

## 6.6 Test conditions power sources and ambient temperatures

### 6.6.1 Normal and extreme test conditions

Conformity testing shall be carried out under normal test conditions (clause 6.7) and also where stated under extreme test conditions (clauses 6.8.1 and 6.8.2 applied simultaneously).

### 6.6.2 Test power source

Where stated, the battery of the equipment shall be replaced by a test power source capable of producing normal (clause 6.7.2) and extreme test voltages as specified in clauses 6.8.2.1 and 6.8.2.2.

## 6.7 Normal test conditions

### 6.7.1 Normal temperature and humidity

Normal temperature and humidity conditions for tests shall be any convenient combination of temperature and humidity, within the following ranges:

- Temperature: +15 °C to +35 °C.
- Relative humidity: 20 % to 75 %.

### 6.7.2 Normal test voltage

The normal test voltage shall be determined in each case and shall be the voltage corresponding to the voltage that a fresh battery gives at normal temperature and humidity at a load equal to that of the equipment when activated.

## 6.8 Extreme test conditions

### 6.8.1 Extreme temperatures

For tests at extreme temperatures, measurements shall be made in accordance with the procedure specified herein at the lower and upper temperatures of -20 °C and +55 °C respectively except when installed within other equipment subject to more stringent temperature requirements, in which case the more stringent requirements shall apply.

The equipment shall be switched off during the temperature stabilization period.

Before tests are carried out, the equipment shall have obtained thermal balance in the test chamber and have been activated for a period of 5 minutes.

The location of the equipment under test in the climatic chamber shall not substantially influence the power output or the power consumption of the equipment under test.

### 6.8.2 Extreme test voltages

#### 6.8.2.1 Upper extreme test voltage

The upper extreme test voltage shall be determined in each case and shall be the voltage corresponding to the voltage that a fresh battery gives at the upper extreme temperature with a load equal to that of the equipment when activated.

### 6.8.2.2 Lower extreme test voltage

The lower extreme test voltage shall be determined in each case. The equipment fitted with a primary battery shall be placed in a climatic chamber and cooled to -20 °C allowing a stabilization period of 2 hours. The equipment shall then be activated for a period of 6 hours. After this period the battery voltage shall be measured. This voltage shall be taken as the lower extreme test voltage and shall be measured before disconnecting the battery.

---

## 7 Environmental tests

### 7.1 Introduction

The requirements of this clause demonstrate that the equipment is capable of continuous operation under the conditions of various sea states, vibration, humidity and change of temperature likely to be experienced on a ship in which it is carried.

### 7.2 Procedure

Environmental tests shall be carried out before tests in respect of the other requirements in the present document are performed on the same EUT. Environmental tests may be carried out in any order but the test specified in clause 7.13 shall always be carried out last so as to detect any damage to EUT's water seals caused by the other environmental tests.

### 7.3 Performance check

The term performance check as used in the present document shall be that of activating the locating device in test mode with GNSS data available, and checking the reception of Message 1 and Message 14 using a suitable AIS receiver.

The performance check shall be carried out only under normal test conditions as detailed in clause 6.7.1 unless otherwise stated.

### 7.4 Drop test

#### 7.4.1 Definition

The immunity against the effects of dropping is the ability of the equipment to maintain the specified mechanical and electrical performance after being subjected to a series of drops onto a hard wooden test surface and into water.

#### 7.4.2 Test conditions

During the test, the equipment shall be fitted with a suitable set of batteries and antenna but it shall be switched off. The test shall be carried out under normal temperature and humidity conditions as detailed in clause 6.7.1.

The hard wooden test surface shall consist of a piece of solid hard wood with a minimum thickness of 15 cm and a mass of at least 30 kilograms.

A container of calm sea water shall be used as the other surface.

The height of the lowest part of the equipment under test, relative to the test surface at the moment of release, shall be:

- i) For drops onto the wooden test surface - 1 m.
- ii) For drops onto the water - 20 m.

Equipment shall be subjected to this test in the configuration as it is normally used in operational circumstances.

### 7.4.3 Method of measurement

Equipment that can be armed shall be armed before testing (see clause 4.2).

For drop into water the test shall consist of a single drop test, and the test shall be performed on the EUT complete with any detachable shock absorbers, which are normally part of it (e.g. a life vest).

For drops on the wooden surface the test shall consist of six drops, once on each face, and the test shall be performed on the EUT alone excluding detachable shock absorbers.

### 7.4.4 Requirements

After the drops have been completed the equipment shall be inspected visually for signs of damage. Inspection for mechanical damage, both internal and external, shall be carried out. Any damage shall not impair the operation of the equipment. In particular, parts like knobs, switches and the antenna shall operate in the normal manner. For devices without a water immersion sensor the act of dropping shall not cause the equipment to activate. For devices with a water immersion sensor the act of dropping onto the wooden test surface shall not cause the equipment to activate, whereas drops into water shall always cause the equipment to activate.

The requirement for the performance check (clause 7.3) shall also be met.

## 7.5 Temperature tests

### 7.5.1 Definition

The immunity against the effects of temperature is the ability of the equipment to maintain the specified mechanical and electrical performance after the following tests have been carried out.

The maximum rate of raising or reducing the temperature of the chamber in which the equipment is being tested shall be 1 °C/minute.

### 7.5.2 Dry heat test

#### 7.5.2.1 Method of measurement

The equipment shall be placed in a chamber at normal temperature. The temperature shall then be raised to, and maintained at, +70 °C ( $\pm 3$  °C) for a period of at least 10 hours. After this period any climatic control device provided in the equipment may be switched on and the chamber cooled to +55 °C ( $\pm 3$  °C). The cooling of the chamber shall be completed within 30 minutes.

At the end of this period the EUT shall be subjected to the performance check.

The temperature shall then be maintained at +55 °C ( $\pm 3$  °C) for a period of 10 hours to 16 hours.

At the end of this period the EUT shall again be subjected to the performance check. The temperature of the chamber shall be maintained at +55 °C ( $\pm 3$  °C) during the whole of the performance check periods.

At the end of the test, the EUT shall be returned to normal environmental conditions or to those at the start of the next test.

#### 7.5.2.2 Requirements

The test shall not cause the equipment to activate or operate spuriously.

The requirement for the performance check (clause 7.3) shall also be met.

## 7.5.3 Damp heat test

### 7.5.3.1 Method of measurement

The EUT shall be placed in a chamber at normal room temperature and relative humidity. The temperature shall then be raised to +40 °C ( $\pm 2$  °C), and the relative humidity raised to 93 % ( $\pm 3$  %) over a period of 3 hours  $\pm$  0,5 hours. These conditions shall be maintained for a period of 10 hours to 16 hours.

The EUT shall be switched on 30 minutes later, or after such period as agreed with the manufacturer, and shall be kept operational for at least 2 hours during which period the EUT shall be subjected to the performance check. The temperature and relative humidity of the chamber shall be maintained as specified during the whole test period.

At the end of the test period and with the EUT still in the chamber, the chamber shall be brought to room temperature in not less than 1 hour. At the end of the test the EUT shall be returned to normal environmental conditions or to those required at the start of the next test.

### 7.5.3.2 Requirements

The test shall not cause the equipment to activate or operate spuriously.

The requirement for the performance check (clause 7.3) shall also be met.

## 7.5.4 Low temperature test

### 7.5.4.1 Method of measurement

The equipment shall be placed in a chamber at normal room temperature. Then the temperature shall be reduced to and maintained at -30 °C ( $\pm 3$  °C) for a period of at least 10 hours. Any climatic devices provided within the equipment may then be switched on and the chamber shall be warmed to -20 °C ( $\pm 3$  °C). The warming of the chamber shall be completed within 30 minutes ( $\pm 5$  minutes).

At the end of this period the EUT shall be subjected to the performance check.

The temperature shall then be maintained at -20 °C ( $\pm 3$  °C) for a period of 10 hours to 16 hours.

At the end of this period the EUT shall again be subjected to the performance check. The temperature of the chamber shall be maintained at -20 °C ( $\pm 3$  °C) during the whole of the performance check periods.

### 7.5.4.2 Requirements

The test shall not cause the equipment to activate or operate spuriously.

The requirement for the performance check (clause 7.3) shall also be met.

## 7.5.5 Low temperature battery endurance test

### 7.5.5.1 Method of measurement

Using a fresh battery, the equipment shall be activated (at the ambient temperature) for a period of time as stated by the manufacturer to be equivalent to the loss of battery capacity due to selftesting, stand-by loads as well as battery self-discharge during the useful life of the battery (as defined in clause 4.7.1).

Alternatively the manufacturer may precondition a fresh battery by another means to achieve the same level of discharge as defined in clause 4.7.1, the method shall be recorded in the test report.

The equipment shall then be placed in a chamber at normal room temperature. Then the temperature shall be reduced to and maintained at  $-20\text{ °C} \pm 3\text{ °C}$  for a period of 10 h to 16 h. Any climatic control device provided in the equipment may be switched on at the conclusion of this period. The equipment shall be activated and the transmissions of the equipment during the test shall be verified for a period of 12 h. The temperature of the chamber shall be maintained as specified above for the whole of the period of 12 h. At the end of the test the EUT shall be returned to normal environmental conditions.

#### 7.5.5.2 Requirements

The equipment shall remain activated and transmitting for a minimum of 12 hours.

Following the test the requirement for the performance check (clause 7.3) shall also be met.

### 7.6 Vibration test

#### 7.6.1 Definition

The immunity against the effects of vibration is the ability of the equipment to maintain the specified mechanical and electrical performance when the following test is carried out.

#### 7.6.2 Method of measurement

Equipment that can be armed shall be armed before testing (see clause 4.2).

The equipment, complete with any detachable shock absorbers that are normally part of it (e.g. a life vest), shall be clamped to the vibration table by its normal means of support and in its normal attitude.

The equipment may be suspended to compensate for weight not capable of being withstood by the vibration table.

Provisions may be made to reduce or nullify any adverse effect on the equipment performance which may be caused by the presence of any electro-magnetic fields from the vibration table.

Taking at least 15 minutes to cover each octave of frequency, the equipment shall be subjected to sinusoidal vertical vibration at all frequencies between:

- 2 Hz or 5 Hz up to 13,2 Hz with an excursion of  $\pm 1\text{ mm} \pm 10\%$ ;
- 13,2 Hz up to 100 Hz with a constant maximum acceleration of  $7\text{ m/s}^2$ .

A resonance search shall be carried out during the vibration test. If any resonance of the EUT has Q greater than 5 measured relative to the base of the vibration table, the EUT shall be subjected to a vibration endurance test at each resonant frequency at the vibration level specified in the test with a duration of 2 h. If no resonance with Q greater than 5 occurs the endurance test shall be carried out at one single observed frequency. If no resonance occurs the endurance test shall be carried out at a frequency of 30 Hz.

The test shall be repeated with vibration in each of the mutual perpendicular direction in the horizontal plane.

A performance check shall be carried out at least once during each endurance test period and once before the end of each endurance test period.

#### 7.6.3 Requirement

The test shall not cause the equipment to activate or operate spuriously.

The requirement for the performance check (clause 7.3) shall also be met. No damage or mechanical deterioration shall be visible to the naked eye. The EUT if tested with a vibration absorber (e.g. a life jacket) shall not become detached.

## 7.7 Corrosion test

### 7.7.1 Definition

The immunity against the effects of corrosion is the ability of the equipment to maintain the specified mechanical and electrical performance both during and after the following test has been carried out.

### 7.7.2 Method of measurement

Equipment that can be armed shall be armed before testing (see clause 4.2).

The equipment shall be placed in a chamber fitted with apparatus capable of spraying in the form of fine mist, such as would be produced by a spray gun, salt solution to the formula in table 5.

**Table 5: Salt solution formula**

sodium chloride	26,5	g	±10 %
magnesium chloride	2,5	g	±10 %
magnesium sulphate	3,3	g	±10 %
calcium chloride	1,1	g	±10 %
potassium chloride	0,73	g	±10 %
sodium bicarbonate	0,20	g	±10 %
sodium bromide	0,28	g	±10 %
plus distilled water to make the solution up to 1 l.			

Alternatively a 5 % sodium chloride (NaCl) solution may be used. The salt used for the test shall be high quality sodium chloride (NaCl) containing, when dry, not more than 0,1 % sodium iodide and not more than 0,3 % of total impurities.

Salt solution concentration shall be 5 % (±1 %) by weight. The solution shall be prepared by dissolving 5 parts ±1 by weight of salt in 95 parts by weight of distilled or de-mineralized water.

The pH value of the solution shall be between 6,5 and 7,2 at temperature of 20 °C (±2 °C). The pH value shall be maintained within this range during conditioning. For this purpose, diluted hydrochloric acid or sodium hydroxide may be used to adjust the pH value, provided that the concentration of NaCl remains within the prescribed limits. The pH value shall be measured when preparing each new batch of solution.

The spraying apparatus shall be such that the products of corrosion cannot mix with the salt solution contained within the spray reservoir.

The equipment shall be sprayed simultaneously on all its external surfaces with the salt solution for a period of 1 hour. This spraying shall be carried out 4 times with a storage period of 7 days; at 40 °C (±2 °C) after each spraying. The relative humidity during storage shall be maintained between 90 % and 95 %.

At the end of the total period the equipment shall be examined visually.

### 7.7.3 Requirements

The test shall not cause the equipment to activate or operate spuriously.

There shall be no undue deterioration or corrosion of the metal parts, finishes, material, or component parts visible to the naked eye.

In the case of hermetically sealed equipment there shall be no evidence of moisture penetration.



## 7.8 Thermal shock test

### 7.8.1 Definition

The immunity against the effects of thermal shock is the ability of the equipment to maintain the specified mechanical and electrical performance after the following test has been carried out.

### 7.8.2 Method of measurement

The equipment shall be operational but not armed before testing (see clause 4.2).

The equipment shall be placed in an atmosphere of +70 °C ( $\pm 3$  °C) for 1 hour. It shall then be immersed in water at +25 °C ( $\pm 3$  °C) to a depth of 10 cm, measured from the highest point of the equipment to the surface of the water, for a period of 1 hour.

### 7.8.3 Requirements

The test shall not cause the equipment to activate or operate spuriously.

The requirement for the performance check (clause 7.3) shall also be met. No damage shall be visible to the naked eye and the equipment shall not show any sign of significant external damage or harmful penetration of water.

## 7.9 Buoyancy test

### 7.9.1 Definition

Buoyancy, expressed as a percentage, is its buoyant force divided by its gravity force.

### 7.9.2 Method of measurement

The equipment shall be operational but disarmed before testing (see clause 4.2).

For Category 1 equipment the locating device shall be submerged in calm fresh water.

For Category 2 equipment the locating device and its buoyancy device shall be submerged in calm fresh water.

One of the following methods of measurement shall be used:

- the buoyant force shall be measured when the locating device is totally submerged in fresh water. The buoyant force shall be then divided by the measured gravity force. The result shall be recorded; or
- the buoyancy may be calculated by dividing the volume of the unit above the waterline by the total volume of the locating device. The result shall be recorded.

### 7.9.3 Requirements

The test shall not cause the equipment to activate or operate spuriously.

The value of buoyancy shall be at least 5 %.

## 7.10 Compass safe distance test

### 7.10.1 Definition

The compass safe distance is the closest distance to compasses or compass sensors (flux gate, magnetometer) at which the locating device is safe to be stored.

The compass-safe distance  $D_{\min}$  is defined as the distance between the nearest point of the locating device and the centre of the compass or magnetometer at which it will just produce a deviation in the measurement compass or compass sensor of  $X^\circ/H$  where:

- $X$  is  $5,4^\circ$  for the standard compass and  $18^\circ$  for the steering compass, the standby steering compass and the emergency compass.
- $H$  is the horizontal component of the magnetic flux density in  $\mu\text{T}$  of the earth's Geomagnetic field at the place of testing.

### 7.10.2 Method of measurement

Equipment that can be armed shall be armed before testing (see clause 4.2).

The equipment shall be tested in the position and attitude relative to the compass or compass sensor at which the error produced at the compass would be a maximum (figure 3).

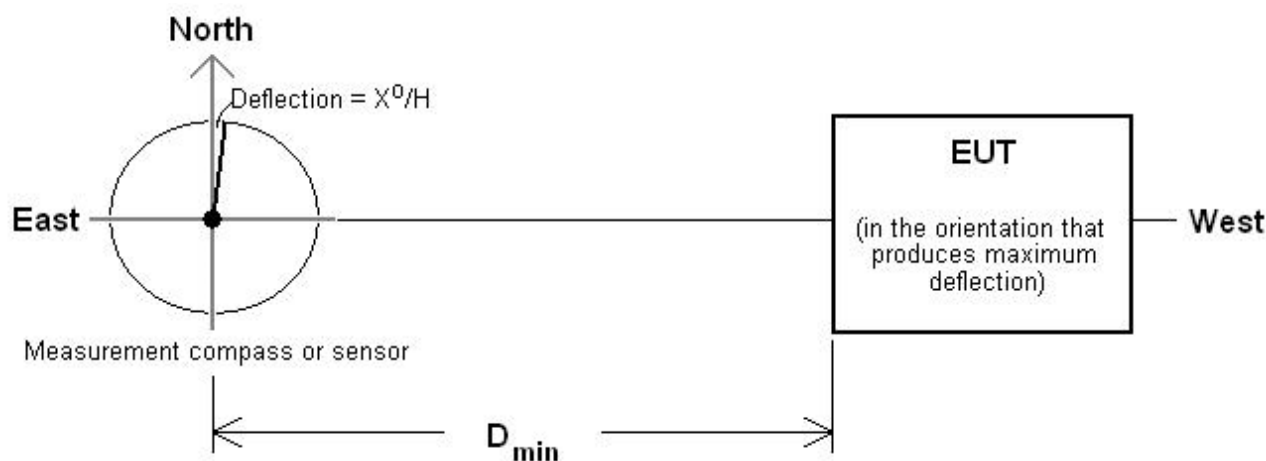

**Figure 3: Compass safe distance test set up**

Steps should be taken to ensure the Geomagnetic field at the test site is uniform.

With the EUT removed from the test site the measurement compass or compass sensor is aligned with magnetic north so that the measured deflection is  $0^\circ$ .

The equipment to be tested (EUT) is then placed in the same plane and on an east west line passing through the centre of the measurement compass or compass sensor. The measurement compass or compass sensor remains stationary and the EUT is moved along the line until the required deflection  $X^\circ/H$  is observed. At this position the EUT is re-oriented until the deflection is maximized. The EUT is then moved again along the east west line until the required deflection  $X^\circ/H$  is again observed. The distance  $D_{\min}$  between the centre of the measurement compass or compass sensor and the nearest point of the EUT is recorded.

### 7.10.3 Requirements

The minimum distance to obtain the required deflection  $D_{\min}$  shall be recorded in the test report.

## 7.11 Solar radiation test

### 7.11.0 Applicability

This test need not be carried out if the manufacturer produces sufficient evidence that the components, materials, etc. maintain their specified mechanical and electrical performance against the effects of continuous solar radiation.

#### 7.11.1 Definition

The immunity against the effects of continuous solar radiation is the ability of the equipment to maintain the specified mechanical and electrical performance after the following test has been carried out.

#### 7.11.2 Method of measurement

Equipment that can be armed shall be armed before testing (see clause 4.2).

The equipment shall be placed on a suitable support and exposed continuously to a simulated solar radiation source (table 6) for 80 hours.

The intensity at the test point, which shall also include any radiation reflected from the test enclosure, shall be  $1\ 120\ \text{W/m}^2 \pm 10\ \%$  with a spectral distribution given in table 6.

**Table 6: Spectral distribution**

Spectral Region	Ultra-violet B	Ultra-violet A	Visible			Infra-red
Bandwidth { $\mu\text{m}$ }	0,28 to 0,32	0,32 to 0,40	0,40 to 0,52	0,52 to 0,64	0,64 to 0,78	0,78 to 3,00
Radiance { $\text{W/m}^2$ }	5	63	200	186	174	492
Tolerance {%}	$\pm 35$	$\pm 25$	$\pm 10$	$\pm 10$	$\pm 10$	$\pm 10$

NOTE: Radiation shorter than 0,30  $\mu\text{m}$  reaching the earth's surface is insignificant.

#### 7.11.3 Requirements

The test shall not cause the equipment to activate or operate spuriously.

No damage shall be visible to the naked eye and the equipment shall not show any sign of significant external damage.

## 7.12 Oil resistance test

### 7.12.0 Applicability

This test need not be carried out if the manufacturer produces sufficient evidence that the components, materials, etc. maintain their specified mechanical and electrical performance against the effects of corrosion.

#### 7.12.1 Definition

The immunity against the effects of immersion in mineral oil is the ability of the equipment to maintain the specified mechanical and electrical performance after the following test has been carried out.

#### 7.12.2 Method of measurement

Equipment that can be armed shall be armed before testing (see clause 4.2).

The equipment shall be immersed horizontally for a period of 24 hours under a 100 mm head of mineral oil as specified below at normal room temperature:

- aniline point: 120 °C;
- flash point: minimum 240 °C;
- viscosity: 10 - 25 cSt at 99 °C.

The following oils may be used:

- ASTM Oil No. 1;
- ASTM Oil No. 5;
- ISO Oil No. 1.

### 7.12.3 Requirements

The test shall not cause the equipment to activate or operate spuriously.

No sign of damage such as shrinking, cracking, swelling, dissolution or change of mechanical qualities of the equipment, including labelling, shall be visible to the naked eye.

## 7.13 Protection of the transmitter

### 7.13.1 Definition

When operating, the locating device transmitter shall not be damaged due to antenna mismatching and shall remain water-tight.

### 7.13.2 Method of measurement

This test shall be carried out on the same sample of the equipment used for testing to, and after all the preceding tests in clause 7 have been carried out.

With the transmitter operating, the equipment shall be completely immersed in water to a depth of 1 m for a period of 5 minutes. For equipment fitted with an extendible antenna, the test shall be carried out with the antenna fully extended, and repeated with the antenna fully retracted under normal test conditions.

Saline solution of normal sea saltness (see corrosion test in clause 7.7) shall be used.

### 7.13.3 Requirement

The test shall not cause the equipment to deactivate or operate spuriously.

No damage shall be visible to the naked eye and the equipment shall not show any sign of significant external damage or harmful penetration of water, and the requirements of the performance check (clause 7.3) shall also be met.

---

## 8 Tests on the AIS transmitter

### 8.1 Frequency error

#### 8.1.1 Definition

The frequency error of the transmitter is the difference between the measured carrier frequency in the absence of modulation and its required frequencies AIS1 and AIS2.

## 8.1.2 Method of measurement

The carrier frequency shall be measured with the equipment placed in the test fixture (see clause 6.4). The measurement shall be made using the test power source (see clause 6.6.2) under both normal and extreme test conditions. The carrier frequency shall be measured in the absence of modulation. The test shall be performed on AIS1 and AIS2.

## 8.1.3 Limit

The frequency error under normal conditions shall not exceed  $\pm 500$  Hz, and under extreme test conditions shall not exceed  $\pm 1$  kHz.

# 8.2 Conducted Power

## 8.2.0 Purpose

The purpose of this test is to verify that the output power from the locating device is within limits at extreme operating temperatures.

## 8.2.1 Definition

This is the average or mean power delivered to the artificial antenna (see clause 6.4) in the absence of modulation.

## 8.2.2 Method of measurement under normal test conditions

The transmitter shall be connected to an artificial antenna (see clause 6.4) and the average or mean power delivered to this artificial antenna shall be measured under normal conditions (see clause 6.7), and at the extremes of temperature (see clause 6.8.1).

A measurement for frequency AIS1 shall be made and repeated for AIS2.

The mean power under normal conditions  $P_{\text{Norm}}$  shall be measured.

The mean power under extreme conditions  $P_{-20}$  and  $P_{+55}$  shall be measured.

The differences between the normal and extreme conditions shall be determined:

$$P_{\text{diff1}} = P_{\text{Norm}} - P_{-20} \quad \text{and} \quad P_{\text{diff2}} = P_{\text{Norm}} - P_{+55}$$

## 8.2.3 Limit

The difference between the conducted power under extreme conditions and the conducted power under normal conditions shall be less than  $\pm 1,5$  dB for both AIS1 and AIS2.

# 8.3 Maximum Effective Radiated Power (ERP)

## 8.3.1 Definition

The Effective Radiated Power (ERP) is the power radiated in the direction of the maximum field strength under the specified conditions of measurements.

### 8.3.2 Method of measurement

The measurement is made under normal conditions (see clause 6.7) for frequency AIS1 and repeated for AIS2.

On a test site selected from clause 5 of ETSI TS 103 052 [7], the equipment shall be placed on a support in the standard position as described in clause 6.8 of ETSI TS 103 052 [7] for equipment intended to be worn on a person, or that described in annex C for equipment not intended to be worn on a person. The transmitter shall be switched on to transmit continuously without modulation.

The receiver shall be tuned to the transmitter carrier frequency. The test antenna shall be orientated for vertical polarization. The test antenna shall be raised or lowered through the specified range of heights until a maximum signal level is detected on the measuring receiver.

The transmitter shall be rotated through 360° around a vertical axis in order to find the direction of the maximum signal.

The maximum signal level detected by the measuring receiver shall be recorded. For equipment tested using the support described in annex C only, the level detected at 90°, 180° and 270° from the maximum shall be recorded avoiding nulls where possible by movement of the receive antenna by no more than 10°.

The transmitter shall be replaced by a substitution antenna as defined in clause 5.3.2 of ETSI TS 103 052 [7].

The substitution antenna shall be connected to a calibrated signal generator.

The frequency of the calibrated signal generator shall be adjusted to the transmit carrier frequency.

The input attenuator setting of the measuring receiver shall be adjusted in order to increase the sensitivity of the measuring receiver, if necessary.

The test antenna shall be raised or lowered through the specified range of heights to ensure that the maximum signal is received.

The input signal to the substitution antenna shall be adjusted to the level that produces a level detected by the measuring receiver that is equal to the level noted to that detected from the equipment under test corrected for the change in input attenuator setting of the measuring receiver.

The maximum ERP is equal to the power supplied by the signal generator, increased by the gain of the substitution antenna and corrected for the change in the attenuator.

### 8.3.3 Limits

For equipment tested using the support described in clause 6.8 of ETSI TS 103 052 [7] the maximum ERP shall be 600 mW +1,5 -3 dB.

For equipment tested using the support described in annex C the average of the four measurements recorded shall be 600 mW +1,5 -3 dB.

NOTE: The -3 dB tolerance is to allow for antenna gain characteristics.

## 8.4 Transmitter spectrum mask

### 8.4.1 Definition

The transmitter spectrum mask defines the limits within the range  $f_c \pm 75$  kHz for the peak power of all modulated signals including all side bands associated with the carrier.

### 8.4.2 Method of measurement

The transmitter shall be connected to an artificial antenna (see clause 6.4) with a means of measuring the power delivered to the load. The equipment shall be operated from the test power source (clause 6.6.2). Standard test signal number 3 (see clause 6.5.3) shall be used to modulate the transmitter in repeated packets.

The measurement shall be made under normal test conditions.

To determine the reference peak power and measure the emissions in the adjacent channels, the emission is suitably applied to the input of a spectrum analyser with the following preferred settings:

- Resolution bandwidth: 1 kHz;
- Video bandwidth: 3 kHz;
- Scan bandwidth: 150 kHz;
- Centre frequency: Carrier frequency AIS1 and AIS2;
- Detector type: Peak hold.

A sufficient number of sweeps shall be used and sufficient transmission packets measured to ensure that the emission profile is fully developed. A reference carrier power shall be calculated as being the maximum power within the frequency limits set in clause 8.1.3. The emission profile shall then be normalized so that the reference carrier power is set to 0 dBc. The result is compared to the mask given in figure 4.

A measurement for frequency AIS1 shall be made and repeated for AIS2.

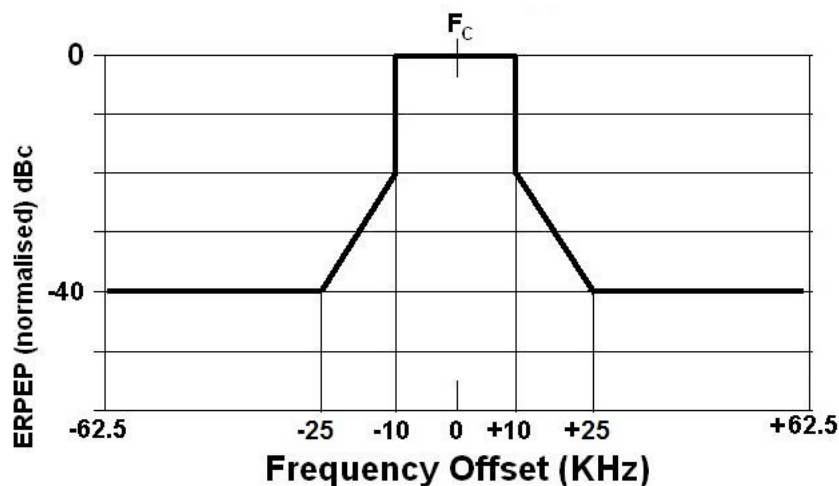

Figure 4: Transmitter spectrum mask

The mask is set as follows:

For  $\pm 10$  kHz the limit is 0 dBc. From  $\pm 10$  kHz to  $\pm 25$  kHz the limit decreases linearly from -20 dBc to -40 dBc. From  $\pm 25$  kHz to  $\pm 62,5$  kHz the limit is -40 dBc.

### 8.4.3 Limit

The normalized emission profile shall not exceed the mask of figure 4.

## 8.5 Transmitter transient behaviour (output power)

### 8.5.1 Definition

The transient behaviour (output power) of the transmitter is determined by the time-dependency of the transmitter power when the transmitter output power is switched on and off. Within the scope of the present document, only the transmit power as a function of time is tested as shown in figure 5 and defined in table 7 where:

- a) transmitter delay time ( $T_A - T_0$ ) is the time between the start of the slot and the moment when the transmit power may exceed -50 dB of the steady-state power ( $P_{SS}$ );
- b) transmitter attack time ( $T_{B2} - T_A$ ) is the time between the transmit power exceeding -50 dBc and the moment when the transmit power maintains a level within +1,5 dB - 1 dB from  $P_{SS}$ ;

- c) transmitter release time (TF - TE) is the time between the end flag being transmitted and the moment when the transmitter output power has reduced to a level 50 dB below  $P_{SS}$  and remains below this level thereafter;
- d) transmission duration (TF - TA) is the time from when power exceeds -50 dBc to when the power returns to and stays below -50 dBc.

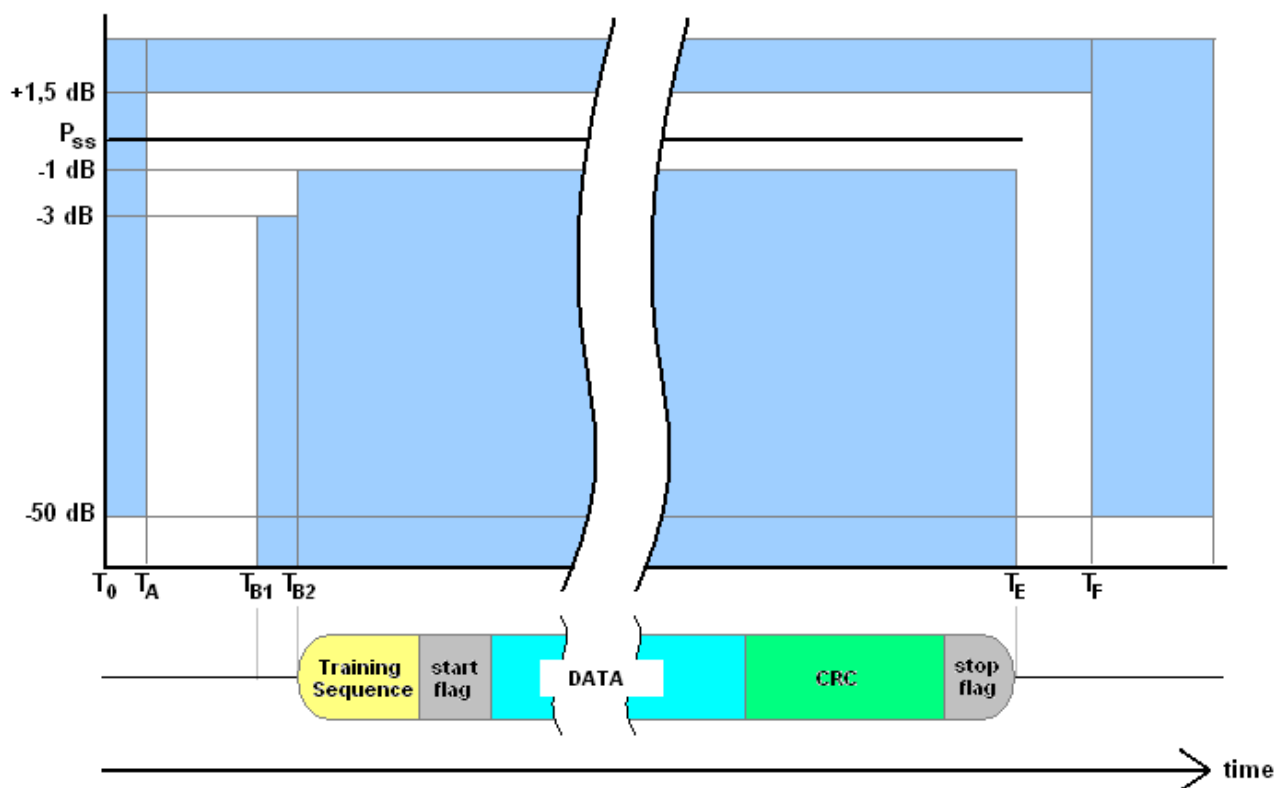

Figure 5: Power versus time mask

Table 7: Definitions of timings

Reference	Bit Periods	Time (ms)	Definition	
$T_0$	0	0	Start of transmission slot. Power shall NOT exceed -50 dB of $P_{SS}$ before $T_0$	
$T_A$	0 to 6	0 to 0,625	$T_A$ = Point at which power exceeds -50 dB of $P_{SS}$	
$T_B$	$T_{B1}$	6	0,625	Power shall be within +1,5 or -3 dB of $P_{SS}$
	$T_{B2}$	8	0,833	Power shall be within +1,5 or -1 dB of $P_{SS}$
$T_E$ (includes 1 stuffing bit)	233	24,271	Power shall remain within +1,5 or -1 dB of $P_{SS}$ during the period $T_{B2}$ to $T_E$ (see note)	
$T_F$ (includes 1 stuffing bit)	241	25,104	Power shall be $\leq$ -50 dB of $P_{SS}$ and stay below this	
$T_G$	256	26,667	Start of next transmission time period	
NOTE: There shall be no modulation of the RF after the termination of transmission (TE) until the power has reached zero and the next slot begins (TG).				

## 8.5.2 Method of measurement

The measurement is made under normal conditions (see clause 6.6) for frequency AIS1 and repeated for AIS2.

The transmitter shall be connected to an artificial antenna (see clause 6.4). The measurement shall be carried out by transmitting test signal number 1.



A spectrum analyser shall be used to make the measurements with the following preferred settings:

- Resolution bandwidth: 1 MHz
- Video bandwidth: 1 MHz
- Scan bandwidth: zero span
- Centre frequency: Carrier frequency as measured in clause 8.1
- Detector type: sample detector [single sweep mode]

The spectrum analyser shall be synchronized to the nominal start time of the slot ( $T_0$ ), which is provided by a modified sample of the EUT submitted by the manufacturer (clause 6.5.4).

### 8.5.3 Limit

The transmitter power shall remain within the mask shown in figure 5 and associated timings given in table 7.

## 8.6 Transmitter Transient Behaviour (frequency deviation)

### 8.6.1 Definition

The transient behaviour (frequency deviation) of the transmitter is determined by the time-dependency of the frequency deviation during the transmission of an AIS message.

A test to verify that the training sequence starts with a 0 and is a 0101 pattern of 24 bits. The peak frequency deviation is derived from the baseband signal to verify modulation accuracy.

### 8.6.2 Method of measurement

The measurement is made under normal and extreme conditions (see clauses 6.6 and 6.7) for frequency AIS1 and repeated for AIS2.

The transmitter shall be connected to an artificial antenna (see clause 6.4) comprising a power attenuator and a suitable measuring device either option A or option B of figure 6.

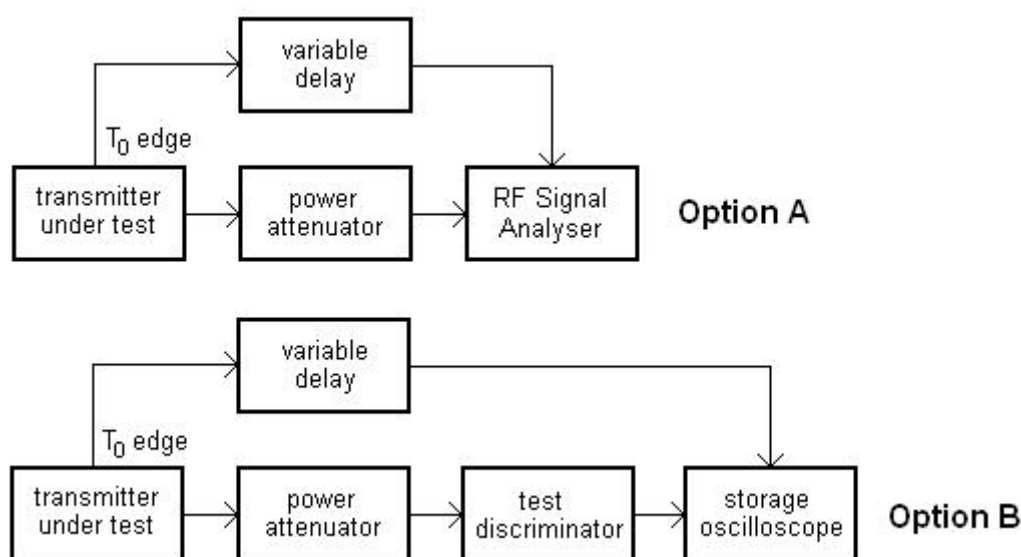

**Figure 6: Measurement arrangement for modulation accuracy**

NOTE: It is permissible to use data recovery filter between the test discriminator and the storage oscilloscope provided that it has a bandwidth of at least 100 KHz.

The measuring device shall be synchronized to the nominal start time of the first preamble bit ( $T_B$ ), using the modified sample of the EUT submitted by the manufacturer (clause 6.5.4). Using test signal 2 the delay from the  $T_0$  timing edge provided by EUT (see clause 6.5.4) is adjusted until the centre position of the first data bit (bit 0) is determined as the trigger point  $T_B$ . Holding these settings test signal 2 is replaced with test signal 1 to confirm that  $T_B$  has been correctly determined.

The transmitter shall be modulated with test signal number 2.

The deviation from the carrier frequency shall be measured as a function of time.

The transmitter shall be modulated with test signal number 1.

The deviation from the carrier frequency shall be measured as a function of time.

### 8.6.3 Limit

In each case the observed training sequence shall begin with a '0'.

The peak frequency deviation at various points within the data frame shall comply with table 8. These limits apply to both the positive and negative modulation peaks. Bit 0 is defined as the first bit of the training sequence.

**Table 8: Peak frequency deviation versus time**

Measurement period from centre to centre of each bit	Test signal 1		Test signal 2	
	Normal	Extreme	Normal	Extreme
Bit 0 to bit 1	$< 3\,400\text{ Hz}$			
Bit 2 to bit 3	$2\,400\text{ Hz} \pm 480\text{ Hz}$			
Bit 4 to bit 31	$2\,400\text{ Hz} \pm 240\text{ Hz}$	$2\,400\text{ Hz} \pm 480\text{ Hz}$	$2\,400\text{ Hz} \pm 240\text{ Hz}$	$2\,400\text{ Hz} \pm 480\text{ Hz}$
Bit 32 to bit 199	$1\,740\text{ Hz} \pm 175\text{ Hz}$	$1\,740\text{ Hz} \pm 350\text{ Hz}$	$2\,400\text{ Hz} \pm 240\text{ Hz}$	$2\,400\text{ Hz} \pm 480\text{ Hz}$

## 8.7 Synchronization accuracy

### 8.7.1 Definition

The synchronization accuracy defines the allowable time deviation including additive jitter in the transmission of an AIS message from ideal SOTDMA timing. The synchronization accuracy test verifies:

- (i) that the EUT transmission will be properly synchronized once UTC lock is acquired;
- (ii) that following UTC lock the EUT will continue properly synchronized transmission if UTC lock is subsequently lost.

This test requires analysis of the transmissions of the EUT in active mode. Care shall be taken to ensure that transmissions are not received by a nearby AIS receiver such as a coastal shore station.

### 8.7.2 Method of measurement

The EUT shall be programmed with valid UTC parameters as described in the user documentation or shall be preconditioned so as to have downloaded valid UTC parameters before the start of the test.

The measurement is made under normal and extreme conditions (see clauses 6.7 and 6.8) for frequency AIS1 and repeated for AIS2.

The transmitter shall be connected to an artificial antenna (see clause 6.4). The EUT's GNSS receiver shall be connected to a GNSS simulator simulating more than 3 satellites and that additionally provides a UTC output and a 1 pps reference output with an accuracy of  $\pm 1\ \mu\text{s}$  or better (figure 7).

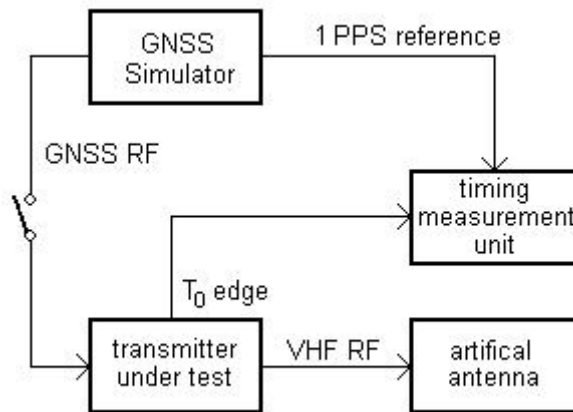

**Figure 7: Measurement arrangement for synchronization accuracy**

- 1) Activate the EUT in active mode with GNSS signal enabled and record transmissions for 40 minutes. After 40 minutes inhibit the GNSS signal and continue to record transmissions for a further 20 minutes.
- 2) Operate the test facility on the EUT with GNSS signal enabled and record transmissions for 6 minutes.
- 3) Operate the test facility on the EUT with GNSS signal inhibited and record transmissions for 6 minutes.

Whenever a transmission is recorded the associated timing difference between the EUT generated  $T_0$  (see clause 6.5.4) edge and the GNSS simulator generated 1 pps reference shall also be recorded. The EUT may pick any one of 75 slots in any two second period. The legitimate timings for both even and odd seconds are given in table 9.

**Table 9: Legitimate  $T_0$  Timings ( $\mu\text{s}$ ) in any second**

Even	Odd	Even	Odd	Even	Odd	Even	Odd
26 667	13 333	293 333	280 000	560 000	546 667	826 667	813 333
53 333	40 000	320 000	306 667	586 667	573 333	853 333	840 000
80 000	66 667	346 667	333 333	613 333	600 000	880 000	866 667
106 667	93 333	373 333	360 000	640 000	626 667	906 667	893 333
133 333	120 000	400 000	386 667	666 667	653 333	933 333	920 000
160 000	146 667	426 667	413 333	693 333	680 000	960 000	946 667
186 667	173 333	453 333	440 000	720 000	706 667	986 667	973 333
213 333	200 000	480 000	466 667	746 667	733 333	-	-
240 000	226 667	506 667	493 333	773 333	760 000	-	-
266 667	253 333	533 333	520 000	800 000	786 667	-	-

The UTC output from the simulator is used by the timing measurement unit to determine when even or odd slot timing measurements apply. The time difference between a legitimate slot start and the measured  $T_0$  shall be compared to the limit of clause 8.7.3.

### 8.7.3 Limit

Verify that in case 8.7.2 (1) and (2) the EUT transmits a valid position within 5 minutes and that all transmissions with a valid position have a synchronization error (including additive jitter) of less than  $\pm 312 \mu\text{s}$ .

Verify that in case 8.7.2 (1) Transmission synchronization error after 40 minutes may drift outside the limit of  $\pm 312 \mu\text{s}$ . The absolute maximum value of the synchronization error after 40 minutes shall be recorded in the test report.

Verify that in cases 8.7.2 (3) the EUT does not transmit at all.

## 8.8 Spurious emissions

### 8.8.1 Definition

Emission(s) on a frequency or frequencies which are outside the necessary bandwidth and the level of which may be reduced without affecting the corresponding transmission of information. Spurious emissions include harmonic emissions, parasitic emissions, intermodulation products, and frequency conversion products, but exclude out-of-band emissions.

### 8.8.2 Method of measurement

On a test site selected from clause 5 of ETSI TS 103 052 [7], the equipment shall be placed on a support in the standard position as described in clause 6.8 of ETSI TS 103 052 [7] for equipment intended to be worn on a person, or that described in annex C for equipment not intended to be worn on a person. The transmitter shall be switched on to transmit continuously without modulation.

The method of measurement described in clause 8.3 shall be used to search for spurious emissions in the frequency band 30 MHz to 2 GHz, excluding the frequency band tested in clause 8.4.

The measuring receiver shall have a bandwidth of 100 kHz to 120 kHz.

The measurement shall only be performed under normal test conditions (see clause 6.7), the locating device being rotated until the maximum emission is detected. The measurement is also made when the locating device has been activated but is not transmitting.

### 8.8.3 Limit

The power of any spurious emission component when transmitting shall not exceed 25  $\mu$ W between 108 MHz to 137 MHz, 156 MHz to 161,5 MHz, and 1 525 MHz to 1 610 MHz.

The power of any spurious emission component when not transmitting (even when activated) shall not exceed 2 nW between 30 MHz and 1 GHz and 20 nW between 1 GHz and 2 GHz.

---

## 9 VDL Link layer tests

### 9.1 Active mode tests

#### 9.1.0 Precaution

These tests require analysis of the transmissions of the EUT in active mode. Care shall be taken to ensure that transmissions are not received by a nearby AIS receiver such as a coastal shore station.

#### 9.1.1 Method of measurement

Activate the EUT in active mode and record transmissions for 40 minutes. Inhibit GNSS data and record transmissions for a further 20 minutes.

Record the activation time of the EUT.

For all transmitted messages record:

- transmission time (UTC);
- transmission slot;
- in-slot timing;
- transmission channel;

- message content.

The records will be evaluated in the following test items.

### 9.1.2 Initialization period - Required results

The following is required:

- a) The first message is transmitted within 60 seconds after activation.
- b) The first message with a valid position is transmitted within 5 minutes.

### 9.1.3 Message content of Message 1 - Required results

For position reports transmitted after 5 minutes and before 40 minutes the following is required:

- a) Message ID = 1.
- b) Repeat indicator = 0.
- c) User ID as configured in the EUT.
- d) Navigational status = 14.
- e) Rate of turn = default.
- f) SOG = actual SOG from GNSS receiver.
- g) Position accuracy = according to the RAIM result if provided, otherwise 0.
- h) Position = actual position from internal GNSS receiver.
- i) Position is updated at least once per minute, for each burst.
- j) COG = actual COG from internal GNSS receiver.
- k) True heading = default.
- l) Time stamp = actual UTC second (0...59).
- m) Verify correct indication according to manufacturer's documentation.

### 9.1.4 Message content of Message 14 - Required results

The following is required:

- a) Message ID = 14.
- b) Repeat indicator = 0.
- c) Source ID = as configured in the EUT.
- d) Text = "MOB ACTIVE".

### 9.1.5 Transmission schedule for Message 1 - Required results

For position reports transmitted after 15 minutes and before 40 minutes the following applies:

- a) Verify that the EUT has operated in sync mode 0 (UTC direct).
- b) The EUT transmits one burst of messages once per minute.
- c) The duration of a burst is 14 s.
- d) A burst consists of 8 messages.

- e) The transmissions in a burst are alternating between AIS1 and AIS2.
- f) Consecutive messages are 75 slots apart and on the other channel.
- g) The same set of slots is used in each burst for 8 minutes.
- h) A new set of slots is randomly selected after 8 minutes.
- i) The first slot of the new set of slots is within the interval of 1 minute  $\pm$  6 seconds from the first slot of the previous set of slots, that is the increment is randomly selected in the range 2 025 to 2 475 slots.
- j) The manufacturer is to provide documentation on how the increment is selected randomly.

### 9.1.6 Communication state of Message 1 - Required results

For position reports transmitted after 5 minutes and before 40 minutes the following applies:

- a) The SOTDMA communication state as defined for message 1 is used.
- b) The sync state = 0.
- c) The time-out starts with 7 for all messages of the first burst after a change in slots.
- d) The time-out value is decremented by 1 for each frame.
- e) The time-out value is reset to 7 after time-out = 0.
- f) The sub message for time-out 3,5,7 = number of received stations (0).
- g) The sub message for time-out 2,4,6 = slot number.
- h) The sub message for time-out 1 = UTC hour and minute.
- i) The sub message for time-out 0 = slot offset to the transmission slot in the next frame.

### 9.1.7 Transmission schedule of Message 14 - Required results

The following is required:

- a) Message 14 is transmitted every 4 minutes.
- b) The transmissions of Message 14 are alternating between AIS1 and AIS2.
- c) Message 14 is transmitted in a Message 1 slot, replacing the Message 1, on the channel for which the Message 1 was scheduled.
- d) Message 14 did not replace a Message 1 with a time-out value = 0.

### 9.1.8 Transmission with lost GNSS - Required results

For position reports transmitted after 45 minutes the following applies:

- a) The EUT continues transmission.
- b) The same transmission schedule is used as with GNSS data available.
- c) Communication State Sync state = 3.
- d) SOG = last valid SOG.
- e) Position accuracy = low.
- f) Position = last valid position.
- g) COG = last valid COG.

- h) Time stamp = 63.
- i) RAIM-flag = 0.
- j) Verify correct indication as per manufacturer's documentation.

## 9.2 Test mode tests with GNSS data available

### 9.2.1 Method of measurement

These tests require analysis of the transmissions of the EUT in test mode.

Activate the EUT in test mode with GNSS data available and record transmissions.

### 9.2.2 Required results

The following is required:

- a) The EUT starts transmission after valid GNSS data is available.
- b) A single burst of 8 messages in the correct order and correctly populated as per clause B.2.
- c) User ID as configured in the EUT.
- d) Navigational status = 15 (not defined).
- e) SOG = actual SOG from GNSS receiver.
- f) Position accuracy = according to the RAIM result if provided, otherwise 0.
- g) Position = actual position from internal GNSS receiver.
- h) COG = actual COG from internal GNSS receiver.
- i) Time stamp = actual UTC second (0...59).
- j) The communication state time-out always = 0 with sub message = 0.
- k) The transmission of Messages 1 and 14 stops after one burst of 8 messages.
- l) The text message in Message 14 is "MOB TEST".
- m) Verify correct indication as per manufacturer's documentation.

## 9.3 Test mode tests without GNSS data available

### 9.3.1 Method of measurement

These tests require analysis of the transmissions of the EUT in test mode.

Activate the EUT in test mode with no GNSS data available and record transmissions.

### 9.3.2 Required results

The following is required:

- a) The EUT does not transmit within 5 minutes.

## 10 Testing for compliance with technical requirements

### 10.1 Environmental conditions for testing

These shall be as described clause 6.

### 10.2 Interpretation of the measurement results

The interpretation of the results recorded in a test report for the measurements described in the present document shall be as follows:

- The measured value related to the corresponding limit will be used to decide whether equipment meets the requirements of the present document and the measurement shall be related to the tolerance and uncertainty as follows:

$$d_{mv}^2 = d_{pt}^2 + d_{mu}^2$$

Where  $d_{pt}$  is the permitted tolerance for the parameter under test;

$d_{mu}$  is the measurement uncertainty applicable for that parameter; and

$d_{mv}$  is the permitted error in the measured value.

- The value of the measurement uncertainty for the measurement of each parameter shall be included in the test report.
- The recorded value of the measurement uncertainty shall be, for each measurement, equal to or lower than the figures in table 10.

For the test methods, according to the present document, the measurement uncertainty figures shall be calculated and shall correspond to an expansion factor (coverage factor)  $k = 1,96$  or  $k = 2$  (which provide confidence levels of respectively 95 % and 95,45 % in the case where the distributions characterizing the actual measurement uncertainties are normal (Gaussian)). Principles for the calculation of measurement uncertainty are contained in ETSI TR 100 028 [i.2] and [i.3], in particular in annex D of the ETSI TR 100 028-2 [i.3].

Table 10 is based on such expansion factors.

**Table 10: Maximum measurement uncertainty**

Parameter	Maximum uncertainty
RF frequency	$\pm 1 \times 10^{-7}$
Radiated emission of transmitter below 1 GHz	$\pm 4$ dB
Radiated emission of transmitter above 1 GHz	$\pm 6$ dB
Conducted RF power variations using a test fixture	$\pm 0,75$ dB
Transmitter attack time	$\pm 20$ %
Transmitter release time	$\pm 20$ %



## Annex A (informative): Relationship between the present document and the essential requirements of Directive 2014/53/EU

The present document has been prepared under the Commission's standardisation request C(2015) 5376 final [i.5] to provide one voluntary means of conforming to the essential requirements of Directive 2014/53/EU on the harmonisation of the laws of the Member States relating to the making available on the market of radio equipment and repealing Directive 1999/5/EC [i.1].

Once the present document is cited in the Official Journal of the European Union under that Directive, compliance with the normative clauses of the present document given in table A.1 confers, within the limits of the scope of the present document, a presumption of conformity with the corresponding essential requirements of that Directive, and associated EFTA regulations.

**Table A.1: Relationship between the present document and the essential requirements of Directive 2014/53/EU**

Harmonised Standard ETSI EN 303 098				
Requirement			Requirement Conditionality	
No	Description	Reference: Clause No	U/C	Condition
1	Frequency error	8.1	U	
2	Conducted power	8.2	U	
3	ERP	8.3	U	
4	Transmitter spectrum mask	8.4	U	
5	Transient behaviour - output power	8.5	U	
6	Transient behaviour - frequency deviation	8.6	U	
7	Synchronization accuracy	8.7	U	
8	Spurious emissions	8.8	U	

### Key to columns:

#### Requirement:

**No** A unique identifier for one row of the table which may be used to identify a requirement.

**Description** A textual reference to the requirement.

**Clause Number** Identification of clause(s) defining the requirement in the present document unless another document is referenced explicitly.

#### Requirement Conditionality:

**U/C** Indicates whether the requirement is unconditionally applicable (U) or is conditional upon the manufacturer's claimed functionality of the equipment (C).

**Condition** Explains the conditions when the requirement is or is not applicable for a requirement which is classified "conditional".

Presumption of conformity stays valid only as long as a reference to the present document is maintained in the list published in the Official Journal of the European Union. Users of the present document should consult frequently the latest list published in the Official Journal of the European Union.

Other Union legislation may be applicable to the product(s) falling within the scope of the present document.

## Annex B (normative): Locating device message bursts

### B.1 Active mode

In active mode the locating device transmits messages in a burst of 8 messages once per minute. The SOTDMA communication state of Message 1 is used to pre-announce its future transmissions.

The locating device shall transmit Message 1 "Position report" with the Navigational Status set to 14 and Message 14 broadcast safety related message with the text "MOB ACTIVE". Message 14 shall be transmitted nominally every 4 minutes and replace one of the position reports on both channels.

The locating device transmissions shall alternate between AIS1 and AIS2.

The 1<sup>st</sup> and 5<sup>th</sup> burst shall be as follows:

- AIS1, Message 1, Nav Status = 14, comm-state (time-out={7,3}, sub-message=0)
- AIS2, Message 1, Nav Status = 14, comm-state (time-out={7,3}, sub-message=0)
- AIS1, Message 1, Nav Status = 14, comm-state (time-out={7,3}, sub-message=0)
- AIS2, Message 1, Nav Status = 14, comm-state (time-out={7,3}, sub-message=0)
- AIS1, Message 14 "MOB ACTIVE"
- AIS2, Message 14 "MOB ACTIVE"
- AIS1, Message 1, Nav Status = 14, comm-state (time-out={7,3}, sub-message=0)
- AIS2, Message 1, Nav Status = 14, comm-state (time-out={7,3}, sub-message=0)

The 2<sup>nd</sup>, 4<sup>th</sup>, 6<sup>th</sup> burst shall be as follows:

- AIS1, Message 1, Nav Status = 14, comm-state (time-out={6,4,2}, sub-message=slot)
- AIS2, Message 1, Nav Status = 14, comm-state (time-out={6,4,2}, sub-message=slot)
- AIS1, Message 1, Nav Status = 14, comm-state (time-out={6,4,2}, sub-message=slot)
- AIS2, Message 1, Nav Status = 14, comm-state (time-out={6,4,2}, sub-message=slot)
- AIS1, Message 1, Nav Status = 14, comm-state (time-out={6,4,2}, sub-message=slot)
- AIS2, Message 1, Nav Status = 14, comm-state (time-out={6,4,2}, sub-message=slot)
- AIS1, Message 1, Nav Status = 14, comm-state (time-out={6,4,2}, sub-message=slot)
- AIS2, Message 1, Nav Status = 14, comm-state (time-out={6,4,2}, sub-message=slot)

The 3<sup>rd</sup> burst shall be as follows:

- AIS1, Message 1, Nav Status = 14, comm-state (time-out=5, sub-message=0)
- AIS2, Message 1, Nav Status = 14, comm-state (time-out=5, sub-message=0)
- AIS1, Message 1, Nav Status = 14, comm-state (time-out=5, sub-message=0)
- AIS2, Message 1, Nav Status = 14, comm-state (time-out=5, sub-message=0)
- AIS1, Message 1, Nav Status = 14, comm-state (time-out=5, sub-message=0)

- AIS2, Message 1, Nav Status = 14, comm-state (time-out=5, sub-message=0)
- AIS1, Message 1, Nav Status = 14, comm-state (time-out=5, sub-message=0)
- AIS2, Message 1, Nav Status = 14, comm-state (time-out=5, sub-message=0)

The 7<sup>th</sup> burst shall be as follows:

- AIS1, Message 1, Nav Status = 14, comm-state (time-out=1, sub-message=utc)
- AIS2, Message 1, Nav Status = 14, comm-state (time-out=1, sub-message=utc)
- AIS1, Message 1, Nav Status = 14, comm-state (time-out=1, sub-message=utc)
- AIS2, Message 1, Nav Status = 14, comm-state (time-out=1, sub-message=utc)
- AIS1, Message 1, Nav Status = 14, comm-state (time-out=1, sub-message=utc)
- AIS2, Message 1, Nav Status = 14, comm-state (time-out=1, sub-message=utc)
- AIS1, Message 1, Nav Status = 14, comm-state (time-out=1, sub-message=utc)
- AIS2, Message 1, Nav Status = 14, comm-state (time-out=1, sub-message=utc)

The 8<sup>th</sup> burst shall be as follows:

- AIS1, Message 1, Nav Status = 14, comm-state (time-out=0, sub-message=incr)
- AIS2, Message 1, Nav Status = 14, comm-state (time-out=0, sub-message=incr)
- AIS1, Message 1, Nav Status = 14, comm-state (time-out=0, sub-message=incr)
- AIS2, Message 1, Nav Status = 14, comm-state (time-out=0, sub-message=incr)
- AIS1, Message 1, Nav Status = 14, comm-state (time-out=0, sub-message=incr)
- AIS2, Message 1, Nav Status = 14, comm-state (time-out=0, sub-message=incr)
- AIS1, Message 1, Nav Status = 14, comm-state (time-out=0, sub-message=incr)
- AIS2, Message 1, Nav Status = 14, comm-state (time-out=0, sub-message=incr)

In the 8<sup>th</sup> burst the increment to the next burst (sub-message=incr) shall be randomly selected between 2 025 and 2 475 slots.

This pattern of transmissions is repeated. It is permissible to start the sequence on AIS2.

Message 14 is transmitted at the 1<sup>st</sup> and 5<sup>th</sup> bursts (slot-time-out = 7 and 3) thereby ensuring that all future Message 14 messages are pre-announced.

---

## B.2 Test mode

When operating in the test mode there shall be one burst of 8 messages, 4 on each channel alternating:

- AIS1, Message 14 "MOB TEST"
- AIS2, Message 1, Nav Status = 15 not defined, comm-state (time-out=0, sub-message=0)
- AIS1, Message 1, Nav Status = 15 not defined, comm-state (time-out=0, sub-message=0)
- AIS2, Message 1, Nav Status = 15 not defined, comm-state (time-out=0, sub-message=0)
- AIS1, Message 1, Nav Status = 15 not defined, comm-state (time-out=0, sub-message=0)

- AIS2, Message 1, Nav Status = 15 not defined, comm-state (time-out=0, sub-message=0)
- AIS1, Message 1, Nav Status = 15 not defined, comm-state (time-out=0, sub-message=0)
- AIS2, Message 14 "MOB TEST"

It is permissible to start the sequence on AIS2.

---

## B.3 Default message field values

On activation or if timed out in test mode, if the GNSS is unable to provide a valid position fix, then the reported position shall be longitude = 181° = not available = default and latitude = 91° = not available = default, COG = not available = default, SOG = not available = default, and the time stamp field shall be set to a value of 63.

If in active mode the GNSS is able to provide a valid position fix but that fix is subsequently lost, then the locating device shall continue to transmit with the last known position, COG and SOG. The time stamp field shall be set to a value of 63 and with the synchronization state set to 3.

## Annex C (normative): Additional Test Supports

### C.1 Float-free support

The equipment shall be oriented in a manner in which it is designed to operate and placed on a circular ground plane capable of rotation through  $360^\circ$  in azimuth. As shown in figure C.1, the rotating ground plane B shall have a minimum diameter of  $1,35\lambda$ , (250 cm) and be made of highly conductive material (aluminium or copper). It shall be located at a reference height  $X = 1,00 \pm 0,10$  m above the test site ground plane A. The equipment shall be mounted within the rotating ground plane B to a level such that its float line is aligned with the ground plane B and the antenna of the equipment orientated as normally deployed. This ground plane shall be extended to fit closely around the equipment and to surround the below-waterline portion of the unit (e.g. using metal foil). An adapter plate which has a close fit to the equipment is recommended.

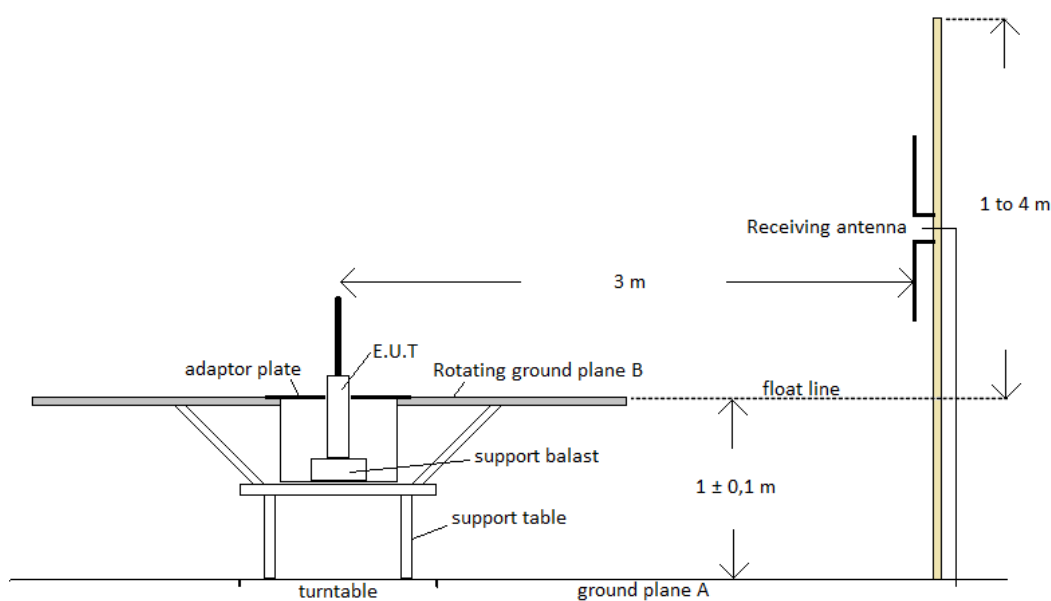

**Figure C.1: Float-free test support**

NOTE: This support is not suitable for making measurements in a fully anechoic as described in clause 5.2.1.2 of ETSI TS 103 052 [7].

---

## Annex D (informative): Bibliography

IEC 61097-14: "Global maritime distress and safety system (GMDSS) - Part 14: AIS search and rescue transmitter (AIS-SART) - Operational and performance requirements, methods of testing and required test results".

---

## Annex E (informative): Change history

Version	Information about changes
2.1.1	First version under the Radio Equipment Directive
2.2.0	Clarifications about tolerances and measurement uncertainties

## History

<b>Document history</b>		
V1.2.1	September 2014	Publication as ETSI EN 303 098-1
V1.2.1	November 2014	Publication as ETSI EN 303 098-2
V2.1.1	May 2016	Publication
V2.2.0	May 2017	EN Approval Procedure AP 20170828: 2017-05-30 to 2017-08-28