

**Electromagnetic compatibility  
and Radio spectrum Matters (ERM);  
Transmitting equipment for terrestrial mobile TV  
to provide multimedia multicast service;  
Part 2: Harmonized EN covering the essential requirements  
of article 3.2 of the R&TTE Directive,  
Test Arrangements for transmitters  
utilizing OFDM technology**

---



---

Reference

DEN/ERM-TG17WG1-004-2

---

Keywords

mobile, multimedia, TV

---

**ETSI**

650 Route des Lucioles  
F-06921 Sophia Antipolis Cedex - FRANCE

---

Tel.: +33 4 92 94 42 00 Fax: +33 4 93 65 47 16

Siret N° 348 623 562 00017 - NAF 742 C  
Association à but non lucratif enregistrée à la  
Sous-Préfecture de Grasse (06) N° 7803/88

---

**Important notice**

---

Individual copies of the present document can be downloaded from:

<http://www.etsi.org>

The present document may be made available in more than one electronic version or in print. In any case of existing or perceived difference in contents between such versions, the reference version is the Portable Document Format (PDF). In case of dispute, the reference shall be the printing on ETSI printers of the PDF version kept on a specific network drive within ETSI Secretariat.

Users of the present document should be aware that the document may be subject to revision or change of status. Information on the current status of this and other ETSI documents is available at

<http://portal.etsi.org/tb/status/status.asp>

If you find errors in the present document, please send your comment to one of the following services:

[http://portal.etsi.org/chaicor/ETSI\\_support.asp](http://portal.etsi.org/chaicor/ETSI_support.asp)

---

**Copyright Notification**

---

No part may be reproduced except as authorized by written permission.  
The copyright and the foregoing restriction extend to reproduction in all media.

© European Telecommunications Standards Institute 2011.  
All rights reserved.

**DECT™**, **PLUGTESTS™**, **UMTS™**, **TIPHON™**, the TIPHON logo and the ETSI logo are Trade Marks of ETSI registered for the benefit of its Members.

**3GPP™** is a Trade Mark of ETSI registered for the benefit of its Members and of the 3GPP Organizational Partners.

**LTE™** is a Trade Mark of ETSI currently being registered

for the benefit of its Members and of the 3GPP Organizational Partners.

**GSM®** and the GSM logo are Trade Marks registered and owned by the GSM Association.

---

# Contents

Intellectual Property Rights .....	4
Foreword.....	4
Introduction .....	4
1 Scope .....	5
2 References .....	5
2.1 Normative references .....	5
2.2 Informative references.....	5
3 Definitions, symbols and abbreviations .....	6
3.1 Definitions .....	6
3.2 Symbols.....	7
3.3 Abbreviations .....	7
4 General measuring arrangements .....	7
4.1 Test conditions .....	7
4.1.1 Test frequency range.....	7
4.1.2 Test modulating signal.....	8
4.2 Test arrangement for measurement of spurious emissions .....	8
4.3 Test arrangement for measurement of out-of-band emissions.....	9
4.4 Test arrangement for measurement of cabinet radiation .....	9
<b>Annex A (normative): HS Requirements and conformance Test specifications Table (HS-RTT).....</b>	<b>11</b>
<b>Annex B (informative): The EN title in the official languages .....</b>	<b>13</b>
<b>Annex C (informative): Bibliography.....</b>	<b>14</b>
History .....	15

---

## Intellectual Property Rights

IPRs essential or potentially essential to the present document may have been declared to ETSI. The information pertaining to these essential IPRs, if any, is publicly available for **ETSI members and non-members**, and can be found in ETSI SR 000 314: "*Intellectual Property Rights (IPRs); Essential, or potentially Essential, IPRs notified to ETSI in respect of ETSI standards*", which is available from the ETSI Secretariat. Latest updates are available on the ETSI Web server (<http://webapp.etsi.org/IPR/home.asp>).

Pursuant to the ETSI IPR Policy, no investigation, including IPR searches, has been carried out by ETSI. No guarantee can be given as to the existence of other IPRs not referenced in ETSI SR 000 314 (or the updates on the ETSI Web server) which are, or may be, or may become, essential to the present document.

---

## Foreword

This final draft Harmonized European Standard (EN) has been produced by ETSI Technical Committee Electromagnetic compatibility and Radio spectrum Matters (ERM), and is now submitted for the Vote phase of the ETSI standards Two-step Approval Procedure.

The present document has been produced by ETSI in response to a mandate from the European Commission issued under Council Directive 98/34/EC [i.1] (as amended) laying down a procedure for the provision of information in the field of technical standards and regulations.

The title and reference to the present document are intended to be included in the publication in the Official Journal of the European Union of titles and references of Harmonized Standard under the Directive 1999/5/EC.

See article 5.1 of Directive 1999/5/EC for information on presumption of conformity and Harmonised Standards or parts thereof the references of which have been published in the Official Journal of the European Union.

The requirements relevant to Directive 1999/5/EC [1] are summarised in annex A.

The present document is part 2 of a multi-part deliverable. Full details of the entire series can be found in part 1 [2].

<b>Proposed national transposition dates</b>	
Date of latest announcement of this EN (doa):	3 months after ETSI publication
Date of latest publication of new National Standard or endorsement of this EN (dop/e):	6 months after doa
Date of withdrawal of any conflicting National Standard (dow):	18 months after doa

---

## Introduction

The present document is part of a set of standards developed by ETSI and is designed to fit in a modular structure to cover all radio and telecommunications terminal equipment within the scope of the R&TTE Directive. The modular structure is shown in EG 201 399 [i.2].

---

# 1 Scope

The present document applies to the following radio equipment types:

- 1) Transmitting equipment for terrestrial mobile TV to provide multimedia multicast service, with 7 MHz and 8 MHz RF channel bandwidths, operating in the CEPT or national frequency bands appropriate for this service.

The present document is intended to cover the provisions of Directive 1999/5/EC [1] (R&TTE Directive), Article 3.2, which states that "..... radio equipment shall be so constructed that it effectively uses the spectrum allocated to terrestrial/space radio communications and orbital resources so as to avoid harmful interference".

In addition to the present document, other ENs that specify technical requirements in respect of essential requirements under other parts of article 3 of the R&TTE Directive [1] may apply to equipment within the scope of the present document.

NOTE: A list of such ENs is included on the web site <http://www.newapproach.org>.

---

# 2 References

References are either specific (identified by date of publication and/or edition number or version number) or non-specific. For specific references, only the cited version applies. For non-specific references, the latest version of the reference document (including any amendments) applies.

Referenced documents which are not found to be publicly available in the expected location might be found at <http://docbox.etsi.org/Reference>.

NOTE: While any hyperlinks included in this clause were valid at the time of publication ETSI cannot guarantee their long term validity.

## 2.1 Normative references

The following referenced documents are necessary for the application of the present document.

- [1] Directive 1999/5/EC of the European Parliament and of the Council of 9 March 1999 on radio equipment and telecommunications terminal equipment and the mutual recognition of their conformity (R&TTE Directive).
- [2] ETSI EN 302 998-1 (V1.1.1) "Electromagnetic compatibility and Radio spectrum Matters (ERM); Transmitting equipment for terrestrial mobile TV to provide multimedia multicast service; Part 1: Harmonized EN covering the essential requirements of article 3.2 of the R&TTE Directive, Common Requirements".
- [3] CENELEC EN 55016-1-1 (2007 + A1:2007 + A2:2008): "Specification for radio disturbance and immunity measuring apparatus and methods - Part 1-1: Radio disturbance and immunity measuring apparatus - Measuring apparatus".
- [4] CISPR 16-2-3 Ed. 2.0 b:2006: "Specification for radio disturbance and immunity measuring apparatus and methods - Part 2-3: Methods of measurement of disturbances and immunity - Radiated disturbance measurements".

## 2.2 Informative references

The following referenced documents are not necessary for the application of the present document but they assist the user with regard to a particular subject area.

- [i.1] Directive 98/34/EC of the European Parliament and of the Council of 22 June 1998 laying down a procedure for the provision of information in the field of technical standards and regulations.

- [i.2] ETSI EG 201 399 (V2.1.1): "Electromagnetic compatibility and Radio spectrum Matters (ERM); A guide to the production of candidate Harmonized Standards for application under the R&TTE Directive".

---

## 3 Definitions, symbols and abbreviations

### 3.1 Definitions

For the purposes of the present document, the following terms and definitions apply:

**antenna port:** port of an apparatus which is designed, in normal operation, to be connected to an antenna using coaxial cable

**cabinet radiation:** emissions from the equipment, radiated from the enclosure port, other than those present at the antenna port

**carrier power:** average power supplied to the antenna port by a transmitter during one radio frequency cycle taken under the condition of no modulation

**class of emission:** set of characteristics of an emission, designated by standard symbols, e.g. type of modulation of the main carrier, modulating signal, type of information to be transmitted, and also, if appropriate, any additional signal characteristics

**dBc:** decibels relative to the unmodulated carrier power of the emission

NOTE: In the cases which do not have a carrier, for example in some digital modulation schemes where the carrier is not accessible for measurement, the reference level equivalent to dBc is decibels relative to the *mean power P*.

**enclosure port:** physical boundary of the apparatus through which electromagnetic fields may radiate or impinge

NOTE: In the case of integral antenna equipment, this port is inseparable from the antenna port.

**environmental profile:** range of environmental conditions under which equipment within the scope of the present document is required to comply with the provisions of the present document

**harmonic:** component of order greater than 1 of the Fourier series of a periodic quantity

**intermodulation products:** unwanted frequencies resulting from intermodulation between carriers or harmonics of emission, or between any oscillations generated to produce the carrier

**mean power:** average power supplied to the antenna port by a transmitter during an interval of time sufficiently long compared with the lowest frequency encountered in the modulation taken under normal operating conditions

**necessary bandwidth:** for a given class of emission, the width of the frequency band which is sufficient to ensure the transmission of information at the rate and with the quality required under specified conditions

**out-of-band emissions:** emissions on a frequency or frequencies immediately outside the necessary bandwidth which results from the modulation process, but exclude spurious emissions

**reference bandwidth:** bandwidth in which the emission level is specified

**spurious emissions:** emissions on a frequency or frequencies which are outside the necessary bandwidth and the level of which may be reduced without affecting the corresponding transmission of information

NOTE: These include harmonic emissions, parasitic emissions, intermodulation products and frequency conversion products but exclude out of band emissions.

**unwanted emissions:** consist of spurious emissions and out-of-band emissions

## 3.2 Symbols

For the purposes of the present document, the following symbols apply:

μ                      Micro

## 3.3 Abbreviations

For the purposes of the present document, the following abbreviations apply:

dB	logarithmic ratio (tenths of a "Bel")
EMC	ElectroMagnetic Compatibility
EUT	Equipment Under Test
FFT	Fast Fourier Transform
GHz	Giga Hertz
kHz	kilo Hertz
LV	Low Voltage
m	metres
MHz	Mega Hertz
M-TV	Mobile TV
OFDM	Orthogonal Frequency Division Multiplex
R&TTE	Radio and Telecommunications Terminal Equipment
RF	Radio Frequency

---

# 4 General measuring arrangements

## 4.1 Test conditions

### 4.1.1 Test frequency range

Limits on unwanted emissions for radio equipments are considered to be applicable to the range 9 kHz to 300 GHz. However, for practical measurement purposes, the frequency range of spurious emissions may be restricted. As guidance for practical purposes, the following measurement parameters in table 4.1 are recommended.

**Table 4.1: Test frequency range**

Transmitter fundamental frequency range	Unwanted emission frequency measurement range	
	lower frequency	upper frequency
47 MHz to 862 MHz	9 kHz	4,5 GHz

The following reference bandwidths are to be used:

For spurious emissions:

- 100 kHz between 9 kHz and 174 MHz;
- 4 kHz between 174 MHz and 400 MHz;
- 100 kHz between 400 MHz and 790 MHz;
- 4 kHz between 790 MHz and 862 MHz;
- 100 kHz between 862 MHz and 1 000 MHz;
- 100 kHz above 1 000 MHz.

For out-of-band emissions:

- 4 kHz.

For Cabinet Radiation measurements please refer to EN 55016-1-1 [3] or CISPR 16-2-3 [4].

### 4.1.2 Test modulating signal

The modulation signal at the input of the transmitter shall be according to OFDM signal defined in the equipment technical specification with the following specific settings:

- The FFT mode supported by the EUT. If more than one mode are supported by the EUT, the mode with the largest FFT size.
- The guard interval duration supported by the EUT. If more than one guard interval duration are supported by the EUT, the guard interval with the shortest duration.
- The modulation constellation supported by the EUT. If more than one modulation constellation are supported by the EUT, the constellation with the highest order.
- The code ratio supported by the EUT. If more than one code ratio are supported by the EUT, an optional code ratio declared by the equipment manufacturer (or the code with the lowest ratio).

## 4.2 Test arrangement for measurement of spurious emissions

See clause 5.3.1 in [2] for initial conditions, test procedure and test requirements.

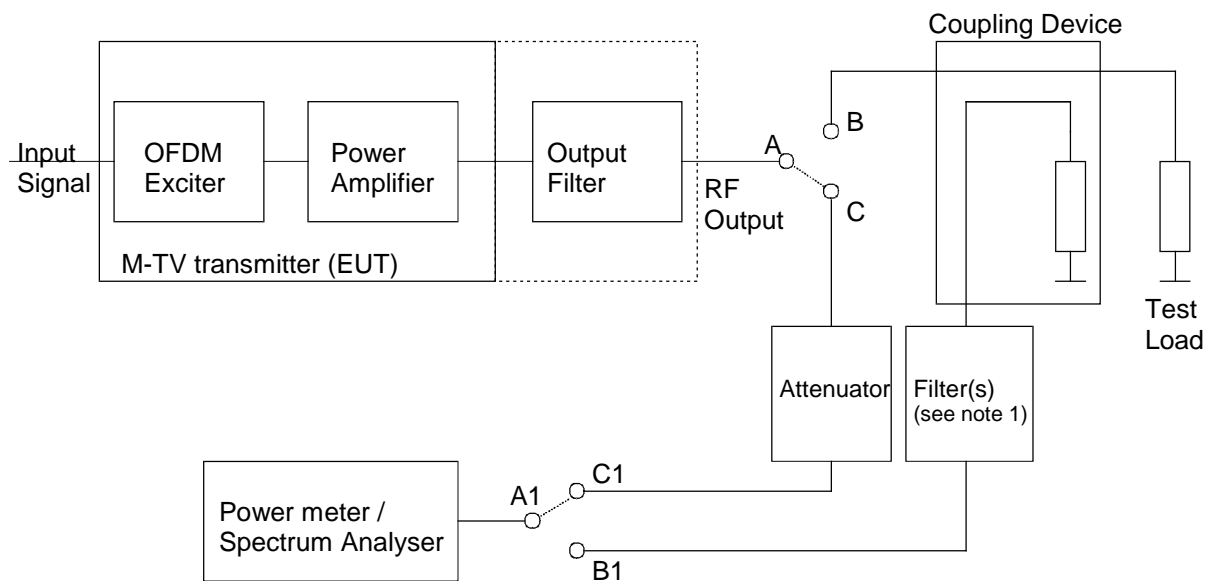

NOTE 1: The optional filter should suppress the output signal so that no intermodulation products are generated by the spectrum analyser. The insertion loss throughout the measuring range should be known.

NOTE 2: For high power transmitters the preferred set up would require A to be connected to B and A1 to be connected to B1.

NOTE 3: For low power transmitters the preferred set up would require A to be connected to C and A1 to be connected to C1.

NOTE 4: If the transmitter does not include any output filter, an external filter shall be added after the transmitter for the testing arrangement. This filter shall be representative of the multiplexer or filter existing in operational conditions and viewed by the transmitted output when installed. In this case, the antenna port measurements shall be performed at the output of this extra filter.

**Figure 4.1: Test arrangement for spurious emissions**



## 4.3 Test arrangement for measurement of out-of-band emissions

See clause 5.3.2 in [2] for initial conditions, test procedure and test requirements.

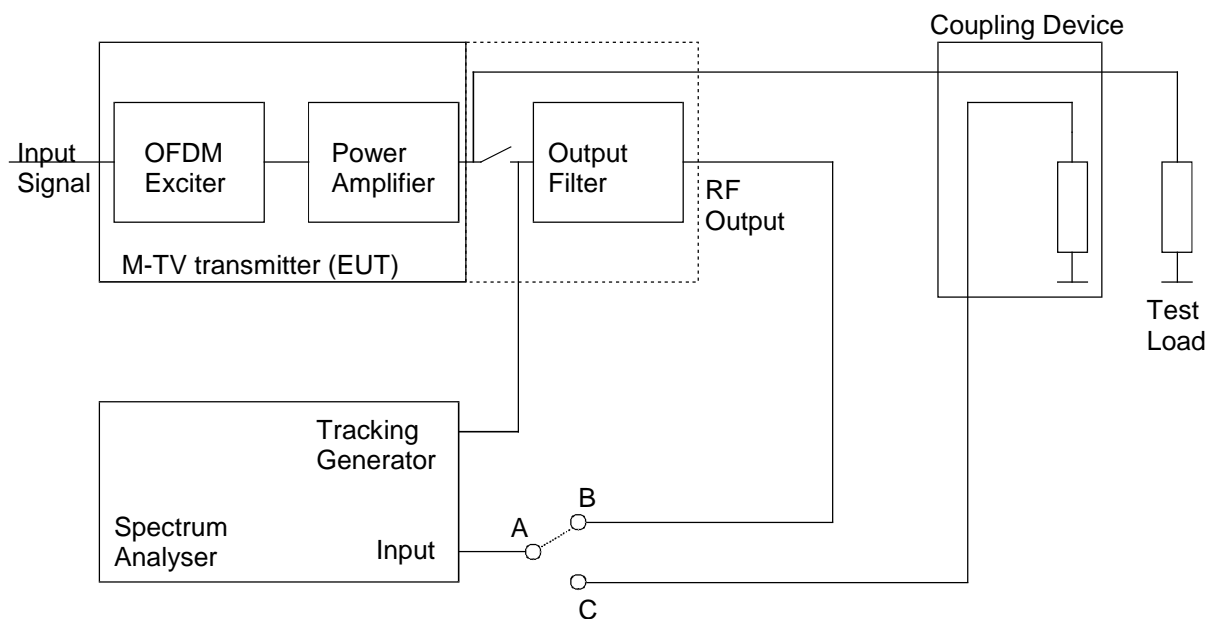

NOTE 1: Disconnect the power amplifier from the output filter.

NOTE 2: The frequency response of the output filter must be measured and recorded (Connection A-B).

NOTE 3: The spectrum of the OFDM signal at the output of the power amplifier must be measured and recorded (Connection A-C).

NOTE 4: The out-of-band spectrum of the OFDM signal shall be calculated by applying the recorded frequency response of the output filter to the recorded spectrum of the OFDM signal.

NOTE 5: If the transmitter does not include any output filter, an external filter shall be added after the transmitter for the testing arrangement. This filter shall be representative of the multiplexer or filter existing in operational conditions and viewed by the transmitted output when installed. In this case, the antenna port measurements shall be performed at the output of this extra filter.

**Figure 4.2: Test arrangement for out-of-band emissions**

## 4.4 Test arrangement for measurement of cabinet radiation

See clause 5.3.3 in [2] for initial conditions, test procedure and test requirements.

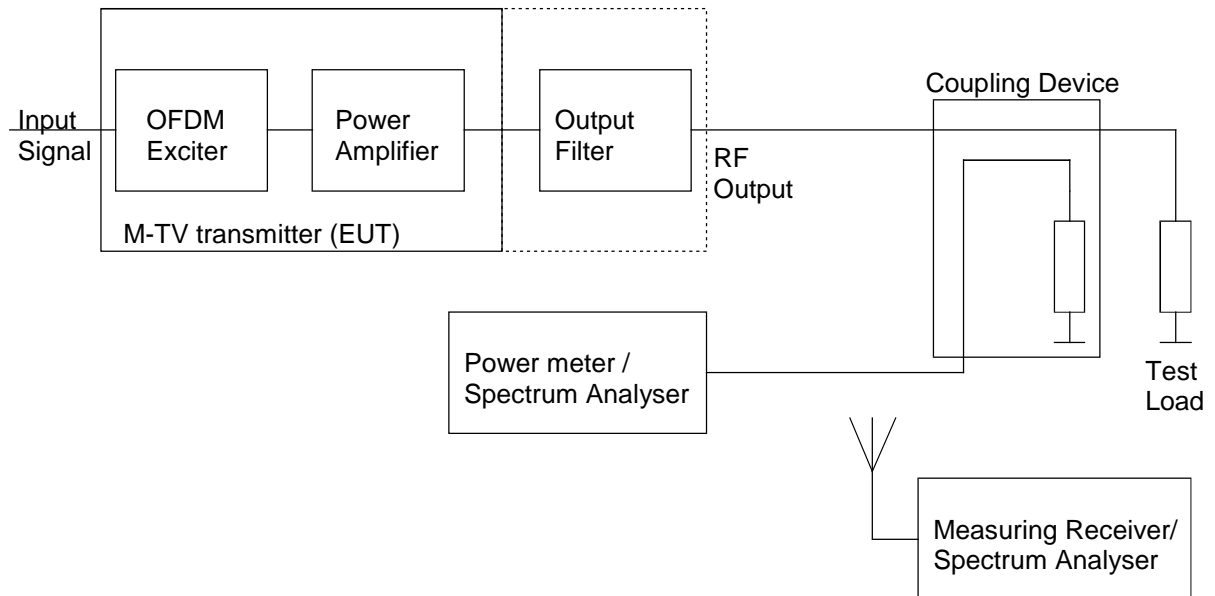

NOTE: If the transmitter does not include any output filter, an external filter shall be added after the transmitter for the testing arrangement. This filter shall be representative of the multiplexer or filter existing in operational conditions and viewed by the transmitted output when installed.

**Figure 4.3: Test arrangement for cabinet radiation**

## Annex A (normative): HS Requirements and conformance Test specifications Table (HS-RTT)

The HS Requirements and conformance Test specifications Table (HS-RTT) in table A.1 serves a number of purposes, as follows:

- it provides a statement of all the requirements in words and by cross reference to (a) specific clause(s) in the present document or to (a) specific clause(s) in (a) specific referenced document(s);
- it provides a statement of all the test procedures corresponding to those requirements by cross reference to (a) specific clause(s) in the present document or to (a) specific clause(s) in (a) specific referenced document(s);
- it qualifies each requirement to be either:
  - Unconditional: meaning that the requirement applies in all circumstances; or
  - Conditional: meaning that the requirement is dependent on the manufacturer having chosen to support optional functionality defined within the schedule.
- in the case of Conditional requirements, it associates the requirement with the particular optional service or functionality;
- it qualifies each test procedure to be either:
  - Essential: meaning that it is included with the Essential Radio Test Suite and therefore the requirement shall be demonstrated to be met in accordance with the referenced procedures;
  - Other: meaning that the test procedure is illustrative but other means of demonstrating compliance with the requirement are permitted.

**Table A.1: HS Requirements and conformance Test specifications Table (HS-RTT)**

Harmonized Standard EN 302 998-2						
The following requirements and test specifications are relevant to the presumption of conformity under the article 3.2 of the R&TTE Directive [1]						
Requirement			Requirement Conditionality		Test Specification	
No	Description	Reference: Clause No	U/C	Condition	E/O	Reference: Clause No
1	Spurious emissions	4.2.2 of [2]	U		E	5.3.1 of [2]
2	Out-of-band emissions	4.2.3 of [2]	U		E	5.3.2 of [2]
3	Cabinet radiations	4.2.4 of [2]	U		E	5.3.3 of [2]

### Key to columns:

#### Requirement:

**No** A unique identifier for one row of the table which may be used to identify a requirement or its test specification.

**Description** A textual reference to the requirement.

**Clause Number** Identification of clause(s) defining the requirement in the present document unless another document is referenced explicitly.

#### Requirement Conditionality:

**U/C** Indicates whether the requirement is to be *unconditionally* applicable (U) or is *conditional* upon the manufacturers claimed functionality of the equipment (C).

**Condition** Explains the conditions when the requirement shall or shall not be applicable for a technical requirement which is classified "conditional".

**Test Specification:**

**E/O** Indicates whether the test specification forms part of the Essential Radio Test Suite (E) or whether it is one of the Other Test Suite (O).

**NOTE:** All tests whether "E" or "O" are relevant to the requirements. Rows designated "E" collectively make up the Essential Radio Test Suite; those designated "O" make up the Other Test Suite; for those designated "X" there is no test specified corresponding to the requirement. The completion of all tests classified "E" as specified with satisfactory outcomes is a necessary condition for a presumption of conformity. Compliance with requirements associated with tests classified "O" or "X" is a necessary condition for presumption of conformity, although conformance with the requirement may be claimed by an equivalent test or by manufacturer's assertion supported by appropriate entries in the technical construction file.

**Clause Number** Identification of clause(s) defining the test specification in the present document unless another document is referenced explicitly. Where no test is specified (that is, where the previous field is "X") this field remains blank.

---

## Annex B (informative): The EN title in the official languages

The enlargement of the European Union (EU) resulted in a requirement from the EU for a larger number of languages for the translation of the titles of Harmonized Standards and mandated ENs that are to be listed in the Official Journal to support the implementation of this legislation.

For this reason the title translation concerning the present document can be consulted via the [e-approval](#) application.

---

## Annex C (informative): Bibliography

Directive 2004/108/EC of the European Parliament and of the Council of 15 December 2004 on the approximation of the laws of the Member States relating to electromagnetic compatibility and repealing Directive 89/336/EEC (EMC Directive).

Directive 2006/95/EC of the European Parliament and of the Council of 12 December 2006 on the harmonisation of the laws of Member States relating to electrical equipment designed for use within certain voltage limits (LV Directive).

CENELEC EN 55011 (1998): "Industrial, scientific and medical (ISM) radio-frequency equipment - Radio disturbance characteristics - Limits and methods of measurement".

CENELEC EN 55022 (1998): "Information technology equipment - Radio disturbance characteristics - Limits and methods of measurement".

ETSI TR 100 028 (all parts): "Electromagnetic compatibility and Radio spectrum Matters (ERM); Uncertainties in the measurement of mobile radio equipment characteristics".

---

## History

<b>Document history</b>			
V1.1.1	July 2010	Public Enquiry	PE 20101109: 2010-07-12 to 2010-11-09
V1.1.1	March 2011	Vote	V 20110520: 2011-03-21 to 2011-05-20