

**Satellite Earth Stations and Systems (SES);
Harmonized EN for Vehicle-Mounted Earth Stations (VMES)
operating in the 14/12 GHz frequency bands
covering the essential requirements
of article 3.2 of the R&TTE directive**



Reference

DEN/SES-00301

Keywords

antenna, earth station, GSO, regulation, satellite

ETSI

650 Route des Lucioles
F-06921 Sophia Antipolis Cedex - FRANCE

Tel.: +33 4 92 94 42 00 Fax: +33 4 93 65 47 16

Siret N° 348 623 562 00017 - NAF 742 C
Association à but non lucratif enregistrée à la
Sous-Préfecture de Grasse (06) N° 7803/88

Important notice

Individual copies of the present document can be downloaded from:

<http://www.etsi.org>

The present document may be made available in more than one electronic version or in print. In any case of existing or perceived difference in contents between such versions, the reference version is the Portable Document Format (PDF). In case of dispute, the reference shall be the printing on ETSI printers of the PDF version kept on a specific network drive within ETSI Secretariat.

Users of the present document should be aware that the document may be subject to revision or change of status. Information on the current status of this and other ETSI documents is available at

<http://portal.etsi.org/tb/status/status.asp>

If you find errors in the present document, please send your comment to one of the following services:

http://portal.etsi.org/chaicor/ETSI_support.asp

Copyright Notification

No part may be reproduced except as authorized by written permission.
The copyright and the foregoing restriction extend to reproduction in all media.

© European Telecommunications Standards Institute 2009.
All rights reserved.

DECT™, **PLUGTESTS™**, **UMTS™**, **TIPHON™**, the TIPHON logo and the ETSI logo are Trade Marks of ETSI registered for the benefit of its Members.

3GPP™ is a Trade Mark of ETSI registered for the benefit of its Members and of the 3GPP Organizational Partners.

LTE™ is a Trade Mark of ETSI currently being registered

for the benefit of its Members and of the 3GPP Organizational Partners.

GSM® and the GSM logo are Trade Marks registered and owned by the GSM Association.

Contents

Intellectual Property Rights	6
Foreword.....	6
Introduction	6
1 Scope	7
2 References	8
2.1 Normative references	8
2.2 Informative references.....	9
3 Definitions, symbols and abbreviations	9
3.1 Definitions	9
3.2 Symbols.....	12
3.3 Abbreviations	12
4 Technical requirements specifications	13
4.1 General	13
4.1.1 Environmental profile	13
4.1.2 Operational configurations	13
4.1.3 Determination of geographic location of the VMES	14
4.1.4 VMES states and radio states.....	14
4.2 Conformance requirements	15
4.2.1 Off-axis spurious radiation	15
4.2.1.1 Justification	15
4.2.1.2 Specification.....	15
4.2.1.3 Conformance tests.....	16
4.2.2 On-axis spurious radiation for VMES	16
4.2.2.1 Justification	16
4.2.2.2 Specification.....	16
4.2.2.2.1 "Carrier-on" radio state.....	16
4.2.2.2.2 "Carrier-off" and "Emissions-disabled" radio states.....	17
4.2.2.3 Conformance tests.....	17
4.2.3 Off-axis e.i.r.p. emission density within the band.....	17
4.2.3.1 Justification	17
4.2.3.2 Specification.....	17
4.2.3.3 Conformance tests.....	19
4.2.4 Carrier suppression	19
4.2.4.1 Justification	19
4.2.4.2 Specification.....	19
4.2.4.3 Conformance tests.....	19
4.2.5 Antenna pointing and polarization alignment for VMESs.....	19
4.2.5.1 Justification	19
4.2.5.2 Specification.....	19
4.2.5.3 Conformance tests.....	20
4.2.6 Cessation of emissions of the VMES.....	21
4.2.6.1 Justification	21
4.2.6.2 Specification.....	21
4.2.6.2.1 Specification 1: Mode of cessation of emissions.....	21
4.2.6.2.2 Specification 2: Conditions under which the VMES must cease emissions.....	21
4.2.6.2.3 Specification 3: Cessation of emissions	22
4.2.6.2.4 Specification 4: Fault conditions	22
4.2.6.3 Conformance tests.....	22
4.2.7 Identification of the VMES.....	22
4.2.7.1 Justification	22
4.2.7.2 Specification.....	22
4.2.7.3 Conformance tests.....	22
4.2.8 Control and Monitoring Functions (CMFs).....	23

4.2.8.1	CMF state diagram	23
4.2.8.2	Processor monitoring	24
4.2.8.2.1	Justification	24
4.2.8.2.2	Specification	24
4.2.8.2.3	Conformance tests	24
4.2.8.3	Transmit subsystem monitoring	24
4.2.8.3.1	Justification	24
4.2.8.3.2	Specification	24
4.2.8.3.3	Conformance tests	24
4.2.8.4	Power-on/Reset	24
4.2.8.4.1	Justification	24
4.2.8.4.2	Specification	24
4.2.8.4.3	Conformance tests	25
4.2.8.5	Control Channel (CC) and Response Channel (RC)	25
4.2.8.5.1	Justification	25
4.2.8.5.2	Specification	25
4.2.8.5.3	Conformance tests	26
4.2.8.6	Network control commands	26
4.2.8.6.1	Justification	26
4.2.8.6.2	Specification	26
4.2.8.6.3	Conformance tests	26
4.2.8.7	Initial burst transmission	26
4.2.8.7.1	Justification	26
4.2.8.7.2	Specification	26
4.2.8.7.3	Conformance tests	27
4.2.8.8	Inhibition of transmissions	27
4.2.8.8.1	Justification	27
4.2.8.8.2	Specification	27
4.2.8.8.3	Conformance tests	27
5	Testing for compliance with technical requirements	27
5.1	Environmental conditions for testing	27
5.2	Essential radio test suites	27
6	Test methods for all aspects of the VMES	28
6.1	General	28
6.2	Off-axis spurious radiation	28
6.2.1	Test method	29
6.3	On-axis spurious radiation	29
6.3.1	Test method	29
6.4	Off-axis e.i.r.p. emission density within the band	29
6.4.1	Test method	29
6.4.1.1	General	29
6.4.1.2	Transmit output power density	30
6.4.1.3	Antenna transmit gain	30
6.4.1.4	Antenna transmit radiation patterns	30
6.4.2	Computation of results	30
6.5	Carrier suppression	31
6.5.1	Test method	31
6.6	Antenna pointing for VMES	31
6.6.1	General	31
6.6.2	Test method	31
6.7	Antenna mechanical stability	31
6.7.1	Test method	31
6.8	Polarization angle alignment capability	31
6.8.1	Test method	32
6.9	Cessation of emissions of the VMES	32
6.9.1	Test Method	32
6.9.1.1	Required documentation	32
6.9.1.2	Cessation of emissions from the "Transmission-enabled" state	32
6.9.1.3	Cessation of emission from the "Transmission-disabled" state	33
6.9.1.4	Cessation of emission from the "Initial Phase" state	33

6.9.1.4.1	EUTs transmitting initial bursts.....	33
6.9.1.4.2	EUTs not transmitting initial bursts.....	33
6.9.1.5	"Single action" means of cessation of emissions.....	34
6.9.1.6	Fault conditions.....	34
6.10	Identification of VMES.....	35
6.10.1	Test arrangement.....	35
6.10.2	Test method.....	35
6.11	Control and monitoring functions.....	35
6.11.1	Test arrangement.....	35
6.11.2	Processor monitoring- Test method.....	35
6.11.3	Transmit subsystem monitoring-Test method.....	35
6.11.4	Power-on/Reset-Test method.....	36
6.11.5	Control Channel and Response Channel -Test method.....	36
6.11.6	Network Control commands-Test method.....	37
6.11.7	Initial burst transmission-Test method.....	38
6.11.8	Inhibition of transmission-Test method.....	38
Annex A (normative):	HS Requirements and conformance Test specifications Table (HS-RTT).....	40
Annex B (informative):	Mechanical stability methodology.....	42
Annex C (informative):	Typical Scan and Acceleration Rates.....	44
Annex D (informative):	The EN title in the official languages.....	45
Annex E (informative):	Bibliography.....	46
History.....		47

Intellectual Property Rights

IPRs essential or potentially essential to the present document may have been declared to ETSI. The information pertaining to these essential IPRs, if any, is publicly available for **ETSI members and non-members**, and can be found in ETSI SR 000 314: *"Intellectual Property Rights (IPRs); Essential, or potentially Essential, IPRs notified to ETSI in respect of ETSI standards"*, which is available from the ETSI Secretariat. Latest updates are available on the ETSI Web server (<http://webapp.etsi.org/IPR/home.asp>).

Pursuant to the ETSI IPR Policy, no investigation, including IPR searches, has been carried out by ETSI. No guarantee can be given as to the existence of other IPRs not referenced in ETSI SR 000 314 (or the updates on the ETSI Web server) which are, or may be, or may become, essential to the present document.

Foreword

This Harmonized European Standard (Telecommunications series) has been produced by ETSI Technical Committee Satellite Earth Stations and Systems (SES), and is now submitted for the Vote phase of the ETSI standards Two-step Approval Procedure.

The present document has been produced by ETSI in response to a mandate from the European Commission issued under Directive 98/34/EC [i.1] (as amended) laying down a procedure for the provision of information in the field of technical standards and regulations.

The present document is intended to become a Harmonized Standard, the reference of which will be published in the Official Journal of the European Communities referencing the Directive 1999/5/EC [1] of the European Parliament and of the Council of 9 March 1999 on radio equipment and telecommunications terminal equipment and the mutual recognition of their conformity ("the R&TTE Directive").

Technical specifications relevant to Directive 1999/5/EC [1] are given in annex A.

Proposed national transposition dates	
Date of latest announcement of this EN (doa):	3 months after ETSI publication
Date of latest publication of new National Standard or endorsement of this EN (dop/e):	6 months after doa
Date of withdrawal of any conflicting National Standard (dow):	18 months after doa

Introduction

The present document is part of a set of standards developed by ETSI and is designed to fit in a modular structure to cover all radio and telecommunications terminal equipment within the scope of the R&TTE Directive [1]. The modular structure is shown in EG 201 399 [i.2].

1 Scope

The present document applies to Earth Stations located on board Vehicles, which have the following characteristics.

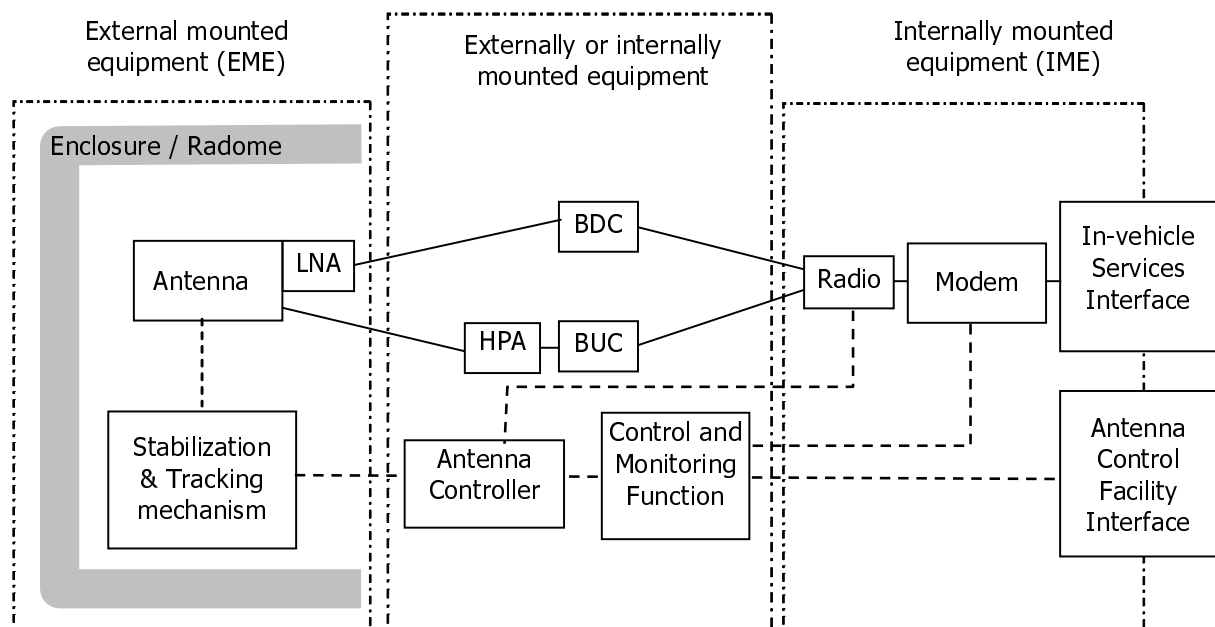

Figure 1: VMES System Overview

- The VMES may transmit and receive data when the vehicle is in motion and also when the vehicle is stationary.
- The VMES operates on wheeled or tracked vehicles and, therefore, may be subject to occasional disturbances and interruptions in the satellite link.
- The VMES is operating as part of a satellite network (e.g. star, mesh or point-to-point) used for the distribution and/or exchange of information.
- The VMES is comprised of all the equipment, electrical and mechanical, from the antenna itself to the interface with other communications equipment on a vehicle (usually referred to as the terrestrial interface).
- The VMES transmits on single carrier in the frequency range 14,00 GHz to 14,50 GHz, which is a band allocated to the Fixed Satellite Services (FSS) (Earth-to-space) among other services. However, operation of the VMES is intended to be restricted to the lower half of the band in and near those countries that have allocated Fixed Service (FS) to the upper half. Local regulation may permit operation in the upper half of the band.

NOTE 1: For the purposes of the present specification, OFDM modulation is considered as a single carrier.

- The VMES receives in one or more frequencies within the range from 10,70 GHz to 12,75 GHz in bands allocated to the Fixed Satellite Services (FSS) (space-to-Earth) or the Broadcast Satellite Service (BSS) (space-to-Earth), depending on the ITU Region where the VMES is located.
- The VMES uses linear or circular polarization.
- The VMES is designed to operate through a geostationary satellite (or a cluster of co-located geostationary satellites) that is at least 3 ° away from any other geostationary satellite operating in the same frequencies and over the same coverage area.

NOTE 2: Satellites may be spaced closer than 3 °. In such cases, the satellite operator will inform the VMES client of the requirements of the system coordination agreements.

- The VMES transmits at elevations greater than or equal to 7 ° relative to the local horizon.
- The VMES is designed for unattended operation.
- The VMES is designed for both mobile and stationary operation. In the case of stationary operation, the VMES must not be accessible to the general public and operated safely.
- The VMES is controlled and monitored by an Antenna Control Facility (ACF). This function may be performed centrally (e.g. for a network of VMESs with a central hub) or it could be performed within the VMES for autonomous control. The ACF is outside the scope of the present document.

The present document applies to the VMES with its ancillary equipment and its various telecommunication ports, and when operated within the boundary limits of the operational environmental profile as declared by the applicant and when installed as required by the applicant's declaration or in the user documentation.

The present document is intended to cover the provisions of Directive 1999/5/EC [1] (R&TTE Directive) article 3.2, which states that "... radio equipment shall be so constructed that it effectively uses the spectrum allocated to terrestrial/space radio communications and orbital resources so as to avoid harmful interference".

NOTE 3: Operational requirements are defined by national administrations and by relevant ECC Decisions.

In addition to the present document, other ENs that specify technical requirements in respect of essential requirements under other parts of article 3 of the Directive 1999/5/EC [1] (R&TTE Directive) may apply to equipment within the scope of the present document.

NOTE 4: A list of such ENs is included on the web site <http://www.newapproach.org/>.

2 References

References are either specific (identified by date of publication and/or edition number or version number) or non-specific.

- For a specific reference, subsequent revisions do not apply.
- Non-specific reference may be made only to a complete document or a part thereof and only in the following cases:
 - if it is accepted that it will be possible to use all future changes of the referenced document for the purposes of the referring document;
 - for informative references.

Referenced documents which are not found to be publicly available in the expected location might be found at <http://docbox.etsi.org/Reference>.

NOTE: While any hyperlinks included in this clause were valid at the time of publication ETSI cannot guarantee their long term validity.

2.1 Normative references

The following referenced documents are indispensable for the application of the present document. For dated references, only the edition cited applies. For non-specific references, the latest edition of the referenced document (including any amendments) applies.

- [1] Directive 1999/5/EC of the European Parliament and of the Council of 9 March 1999 on radio equipment and telecommunications terminal equipment and the mutual recognition of their conformity (R&TTE Directive).
- [2] CISPR 16-1-1 Ed. 2.2 (2007): "Specification for radio disturbance and immunity measuring apparatus and methods - Part 1-1: Radio disturbance and immunity measuring apparatus - Measuring apparatus".

- [3] CISPR 16-1-5 (2003): "Specification for radio disturbance and immunity measuring apparatus and methods; Part 1-5: Radio disturbance and immunity measuring apparatus - Antenna calibration test sites for 30 MHz to 1 000 MHz".
- [4] CENELEC EN 60529 (1991): "Degrees of protection provided by enclosures (IP code)".
- [5] CENELEC EN 60068-2-6 (2008): "Environmental testing - Part 2-6: Tests - Test Fc: Vibration (sinusoidal)".
- [6] CENELEC EN 60068-2-11 (1999): "Environmental testing - Part 2-11: Tests - Test Ka: Salt mist".
- [7] CENELEC EN 60068-2-27 (2007): "Environmental testing - Part 2-27: Tests - Test Ea and guidance: Shock".
- [8] MIL STD 810F (2000): "DOD Test Method Standard for Environmental Engineering Considerations and Laboratory Tests".

2.2 Informative references

The following referenced documents are not essential to the use of the present document but they assist the user with regard to a particular subject area. For non-specific references, the latest version of the referenced document (including any amendments) applies.

- [i.1] Directive 98/34/EC of the European Parliament and of the Council of 22 June 1998 laying down a procedure for the provision of information in the field of technical standards and regulations.
- [i.2] ETSI EG 201 399: "Electromagnetic compatibility and Radio spectrum Matters (ERM); A guide to the production of candidate Harmonized Standards for application under the R&TTE Directive".
- [i.3] ETSI TR 102 375: "Satellite Earth Stations and Systems (SES); Guidelines for determining the parts of satellite earth station antenna radiation patterns concerned by the geostationary satellite orbit protection".
- [i.4] ETSI TR 102 215: "Electromagnetic compatibility and Radio spectrum Matters (ERM); Recommended approach, and possible limits for measurement uncertainty for the measurement of radiated electromagnetic fields above 1 GHz".

3 Definitions, symbols and abbreviations

3.1 Definitions

For the purposes of the present document, the terms and definitions given in Directive 1999/5/EC [1] and the following apply:

ancillary equipment: equipment used in connection with a VMES is considered as ancillary if the three following conditions are met:

- the equipment is intended for use in conjunction with the VMES to provide additional operational and/or control features (e.g. to extend control to another position or location); and
- the equipment cannot be used on a stand alone basis, to provide user functions independently of the VMES; and
- the absence of the equipment does not inhibit the operation of the VMES.

Antenna Control Facility (ACF): set of functional entities that, at system level, monitor and control the correct operation of the VMES and, if appropriate, all of the VMESs in a network

antenna controller: equipment used to maintain antenna stabilization and tracking accuracy based on inputs from the Control and Monitoring Function

applicant: manufacturer or his authorized representative within the European Community or the person responsible for placing the apparatus on the market

carrier-off radio state: radio state in which the VMES may transmit and does not transmit any carrier

NOTE 1: The phrase "the VMES may transmit" means that all the conditions for transmission are satisfied (e.g. in a state where transmissions are permitted, no failure detected, and the VMES is correctly pointed towards the satellite).

NOTE 2: The existence of a "Carrier-off" radio state depends on the system of transmission used. For VMESs designed for continuous transmission mode there may be no "Carrier-off" state.

carrier-on radio state: radio state in which the VMES may transmit and transmits a carrier

Control Channel (CC): channel or channels by which VMESs receive control information from the ACF

EIRP_{max}: maximum e.i.r.p. capability of the VMES as declared by the applicant

emissions-disabled radio state: radio state in which the VMES must not emit

NOTE: Examples of cases where the VMES is in this radio state: before system monitoring pass, before the control channel is received, when a failure is detected, when a VMES is commanded to disable, and when the VMES is in a location requiring cessation of emissions.

external control channel: control channel which is either:

- (i) carried by the VMES network via the same or another satellite, but not within the internal protocol of the VMES system; or
- (ii) carried by any other radio communication system.

Externally Mounted Equipment (EME): that part of the VMES intended to be installed on the outside of the vehicle (usually the roof), as declared by the applicant, or as indicated in the user documentation

NOTE 1: The EME unit is usually comprised of the following main parts:

- a) The antenna sub-system which converts the incident radiation field into a guided wave and vice versa.
- b) The Low Noise Amplifier (LNA) which is a device that amplifies, with very low internal noise, the received signals in the Radio Frequency (RF) band.
- c) The stabilization and tracking mechanics that ensure pointing of the antenna main beam towards the satellite within the required accuracy.
- d) The radome for protecting the antenna subsystem, if required for normal operation.

NOTE 2: The LNA could be replaced by an LNB, which includes the block down converter. Optionally, the EME may include the following elements (otherwise they will be part of the IME):

- a) A Block Up Converter (BUC) and High Power Amplifier (HPA) which convert from the intermediate frequency to RF and amplify the low level RF signals for transmission through the antenna subsystem.
- b) The Antenna Controller Processor.
- c) The Control and Monitoring Function.

NOTE 3: The installation equipment (means of attachment) is outside the scope of the present document. However, the antenna structures and other components directly mounted on the antenna and forming an integral part of it, are subject to the specifications of the present document.

NOTE 4: Certain configurations may include more than one EME per VMES. As for example, the VMES may have separate transmit and receive antennas or it may have redundant transmit/receive antenna units.

external response channel: response channel which is either:

- (i) carried by the VMES network via the same or another satellite, but not within the internal protocol of the VMES system; or
- (ii) carried by any other radio communication system.

integral antenna: antenna which may not be removed during the tests according to the applicant's statement

internal control channel: control channel which is carried by the VMES network via the same satellite as used for transmission of user data and within the internal protocol structure of the VMES system

Internally Mounted Equipment (IME): part of the VMES equipment which is installed inside the vehicle and its connection cables with the EME

NOTE: The IME is usually comprised of:

- a) the modem and the IF radio equipment;
- b) the interfaces to equipment and services onboard the vehicle.

Optionally the IME may include the following elements (otherwise they will be included in the EME):

- c) a Block Down Converter (BDC), which converts the RF signals to intermediate frequencies;
- d) a Block Up Converter (BUC) and High Power Amplifier (HPA) which convert from the intermediate frequency to RF and amplify the low level RF signals for transmission through the antenna subsystem;
- e) the Antenna Controller Processor;
- f) the Control and Monitoring Function.

internal response channel: response channel which is carried by the VMES network via the same satellite as used for transmission of user data and within the internal protocol structure of the VMES system

maximum relative wind speed: addition of the magnitudes of the maximum wind speed and the maximum vehicle velocity

nominated bandwidth: bandwidth of the VMES radio frequency transmission nominated by the applicant

NOTE 1: The nominated bandwidth is centred on the transmit frequency and does not exceed 5 times the occupied bandwidth.

NOTE 2: The nominated bandwidth is wide enough to encompass all spectral elements of the transmission which have a level greater than the specified spurious radiation limits. The nominated bandwidth is wide enough to take account of the transmit carrier frequency stability. This definition is chosen to allow flexibility regarding adjacent channel interference levels which will be taken into account by operational procedures depending on the exact transponder carrier assignment situation.

occupied Bandwidth (Bo):

- for a digital modulation scheme: the width of the signal spectrum 10 dB below the maximum in-band density;
- for an analogue modulation scheme: the width of a frequency band such that, below the lower and above the upper frequency limits, the mean power emitted is equal to 0,5 % of the total mean power of the emission.

off-axis angle: angle between the direction of the axis of the antenna main beam and the considered direction

removable antenna: antenna which may be removed during the tests according to the applicant's statement

Response Channel (RC): channel by which VMES transmit monitoring information to the ACF

spurious radiation: any radiation outside the nominated bandwidth

transmission-disabled state: VMES is in this state when it is not authorized by the ACF to transmit

transmission-enabled state: VMES is in this state when it is authorized by the ACF to transmit

3.2 Symbols

For the purposes of the present document, the following symbols apply:

dBc	ratio expressed in decibels relative to the e.i.r.p. of the unmodulated carrier
dB _i	ratio of an antenna gain to the gain of an isotropic antenna, expressed in decibels
dBW	ratio of a power to 1 watt, expressed in decibels
dBpW	ratio of a power to 1 picowatt, expressed in decibels
dB _μ V/m	ratio of an electric field to 1 μV/m, expressed in decibels (20 log(electric field / 1 μV/m))

3.3 Abbreviations

For the purposes of the present document, the following abbreviations apply:

ACF	Antenna Control Facility
BDC	Block Down Converter
Bo	occupied Bandwidth
BSS	Broadcast Satellite Service
BUC	Block Up Converter
CC	Control Channel
CCF	Control Channel reception Failure
CCR	Control Channel correctly Received
CENR	Cessation of Emissions Not Requested
CEPT	Conférence Européenne des Postes et Télécommunications (European Conference of Postal and Telecommunications Administrations)
CER	Cessation of Emissions Requested
CISPR	Comité International Spécial des Perturbations Radioélectriques (International Special Committee on Radio Interference)
CMF	Control and Monitoring Functions
e.i.r.p.	equivalent isotropically radiated power
ECC	Electronic Communications Committee (of CEPT)
EMC	Electro-Magnetic Compatibility
EME	Externally Mounted Equipment
EN	European Standard
EUT	Equipment Under Test
FEC	Forward Error Correction
FS	Fixed Service
FSS	Fixed Satellite Service
GSO	Geostationary Satellite Orbit
HPA	High Power Amplifier
IME	Internally Mounted Equipment
IPR	Intellectual Property Rights
ITU	International Telecommunications Union
LNB	Low Noise Block down converter
LO	Local Oscillator
LV	Low Voltage
OFDM	Orthogonal Frequency Division Multiplexing
PAME	Polarization Angle Misalignment Error
R&TTE	Radio and Telecommunications Terminal Equipment
RC	Response Channel
RF	Radio Frequency
SMF	System Monitoring Fail
SMP	System Monitoring Pass
STE	Special Test Equipment
TDMA	Time Division Multiple Access
TxD	Transmission Disable command
TxE	Transmission Enable command
VMES	Vehicle-Mounted Earth Station

4 Technical requirements specifications

4.1 General

4.1.1 Environmental profile

The applicant shall declare the environmental profile of the VMES equipment and it shall include conditions for both survivability and operation. The declared environmental profile shall include, but not be limited to, a statement of conditions regarding: vehicle velocity, tangential and longitudinal acceleration, temperature range, damp heat, dry heat, relative humidity stress, shock and vibration, antenna pressure pulses and pressure gradients.

The equipment shall comply with the performance requirements of the present document under all operational environmental conditions as specified in the following table. The VMES shall not show any sign of permanent distortion that could affect the radiation subsystem after the application of the load under the maximum values declared by the applicant for parameters below, including the maximum relative wind speed.

Two classes of VMES are specified and the applicant shall designate the class(es) under which they are compliant.

Table 1: Class A and B VMES Environmental Profiles

Parameter	Class A		Class B [8]	
	Operational / Storage / Survival		Operational	Storage / Survival
High Temperature	+55 °C		501.4: Procedures I and II	
			+70 °C	+85 °C
Low Temperature	-25 °C		502.4: Procedures I and II, -55 °C	
Temperature shock	3 °C/sec up to 40 °C		503.4: +85 °C to -55 °C	
Rain	[4]		506.4: Procedure I - Blowing rain	
Humidity	25 °C - 55 °C, 100 % relative humidity		507.4: High temperature 60 °C Low temperature 20 °C 95 % relative humidity	
Salt Fog	[6]		509.4: 2 cycles	
Sand and dust	[4]		510.4: Blowing dust and blowing sand	
Maximum Vehicle Velocity	To be declared by applicant; but in no case less than 80 km/h		To be declared by applicant; but in no case less than 80 km/h	
Acceleration			513.5: Procedure I. Structural only, 20 g	
Vibration	[5]		514.5: Category 4 - Composite wheeled vehicle vibration exposures Vertical 2,18 grms Lateral 1,6 grms Longitudinal 1,96 grms	
Shock	[7]		516.5	
			11 ms @ 40 g	6 ms @ 75 g
Icing / Freezing rain			521.2: 13mm build-up	
Wind	100 km/h continuous, 160 km/h gusts		100 km/h continuous, 160 km/h gusts	
NOTE:	Based on the above environmental requirements, annex C contains an indication of the typical scan rates and acceleration that would be necessary to achieve compliance.			

4.1.2 Operational configurations

Under operational conditions a VMES may dynamically change the occupied bandwidth and other transmission parameters (e.g. FEC, modulation, symbol rate) of the transmitted signal. For each occupied bandwidth an $EIRP_{max}$ and a nominated bandwidth shall be declared by the applicant. For the purposes of verifying that the VMES complies with these specifications, the applicant may declare the worst case combination of transmission parameters. The following specifications apply to the VMES for each occupied bandwidth and other transmission parameters.

4.1.3 Determination of geographic location of the VMES

The VMES shall have a means of determining its geographic location within the accuracy declared by the applicant and sufficient to maintain operation within all of the parameters declared by the applicant.

4.1.4 VMES states and radio states

For the purpose of the present document the following four VMES states are defined, without presuming the effective implementation of the VMES state machine:

- "Non-valid";
- "Initial phase";
- "Transmission-disabled"; and
- "Transmission-enabled".

The four VMES states are represented on figure 2 and are used in clause 4.2.8 for the specification of the Control and Monitoring Functions (CMFs).

In the "Non-valid" state and in the "Transmission-disabled" state the VMES is not allowed to transmit. In the "Transmission-enabled" state the VMES is allowed to transmit. In the "Initial phase" state the VMES is only allowed to transmit initial bursts or is waiting for a transmit enable/disable command.

The "Initial phase" is divided into three substates:

- "Initial phase-Standby" prior to the transmission of the first initial burst or when no initial bursts are transmitted;
- "Initial phase-BurstOn" during the transmission of the initial bursts;
- "Initial phase-BurstOff" between initial bursts.

NOTE: VMESs which do not transmit initial bursts have no "Initial phase-BurstOn" state and no "Initial phase-BurstOff" state.

The VMES "may transmit" when all the conditions for transmission are satisfied (e.g. in a state where transmissions are permitted, no failure detected, correctly pointed towards the satellite and there is no requirement for cessation of emissions).

The following radio states of the VMES are defined:

- "Emissions-disabled" when the VMES must not transmit any carrier;
- "Carrier-off" when the VMES may transmit and does not transmit any carrier;
- "Carrier-on" when the VMES may transmit and transmits a carrier.

Table 1a gives the only possible combinations of the VMES states and radio states which shall apply, with some examples of associated events.

Table 1a: VMES states and radio states of the VMES

VMES states and substates	Radio states	Examples of events
"Non-valid"	"Emissions-disabled"	After-power on; or After any failure; or During the checking phase.
"Initial phase"		When waiting for a transmission enable or disable command from the ACF.
"Initial phase-Standby"	"Emissions-disabled"	Before the first initial burst transmissions; or In locations where no transmission is allowed.
"Initial phase-BurstOn"	"Carrier-on"	During the transmission of each initial burst, and the pointing is correct.
"Initial phase-BurstOff"	"Carrier-off"	Between initial bursts; or When the pointing threshold is exceeded.
"Transmission-enabled"	"Carrier-off"	When no carrier is transmitted; or When receive synchronization is lost; or When the pointing threshold is exceeded.
	"Carrier-on"	During transmission of carrier(s), and the pointing is correct.
"Transmission-disabled"	"Emissions-disabled"	When a disable command from the ACF has been received and waiting for a transmission enable command from the ACF; or In locations where no transmission is allowed.

4.2 Conformance requirements

4.2.1 Off-axis spurious radiation

4.2.1.1 Justification

To limit the level of interference to terrestrial and satellite radio services.

4.2.1.2 Specification

The following specifications apply to the VMES transmitting at equivalent isotropically radiated power (e.i.r.p.) values up to and including $EIRP_{max}$.

- 1) The electric field strength level of any radiation from the VMES in the frequency range from 30 MHz to 1 GHz shall not exceed the limits specified in table 1b.

Table 1b: Limits of radiated field strength at a test distance of 10 m in a 120 kHz bandwidth

Frequency range	Quasi-peak limits
30 MHz to 230 MHz	30 dB μ V/m
230 MHz to 1 000 MHz	37 dB μ V/m

The Quasi Peak detector shall be in accordance with CISPR 16-1-1 [2].

- 2) When the VMES is in the "Emissions-disabled" radio state, the off-axis spurious e.i.r.p. from the VMES, in any 100 kHz band, shall not exceed the limits in table 2, for all off-axis angles greater than 7 ° or greater than the minimum elevation angle declared by the applicant, whichever is lower.

Table 2: Limits of spurious e.i.r.p. - "Emissions-disabled" radio state

Frequency band	e.i.r.p. limit	Measurement bandwidth
1,0 GHz to 10,7 GHz	48 dBpW	100 kHz
10,7 GHz to 21,2 GHz	54 dBpW	100 kHz
21,2 GHz to 40,0 GHz	60 dBpW	100 kHz

The lower limits shall apply at the transition frequency.

- 3) The present document applies outside the nominated bandwidth. In the "Carrier-on" and "Carrier-off" radio states, the off-axis spurious e.i.r.p. density from the VMES, shall not exceed the limits in table 3, for all off-axis angles greater than 7° or greater than the minimum elevation angle declared by the applicant, whichever is lower.

Table 3: Limits of spurious e.i.r.p. - "Carrier-on" and "Carrier-off" radio states

Frequency band	e.i.r.p. limit	Measurement bandwidth	Remarks
1,0 GHz to 3,4 GHz	49 dBpW	100 kHz	
3,4 GHz to 10,7 GHz	55 dBpW	100 kHz	
10,7 GHz to 13,75 GHz	61 dBpW	100 kHz	
13,75 GHz to 14,0 GHz	95 dBpW	10 MHz	See note 1
14,00 GHz to 14,25 GHz			
14,25 GHz to 14,5 GHz			See note 2
14,5 GHz to 14,75 GHz	95 dBpW	10 MHz	See note 1
14,75 GHz to 21,2 GHz	61 dBpW	100 kHz	
21,2 GHz to 40,0 GHz	67 dBpW	100 kHz	

NOTE 1: This limit may be exceeded in a frequency band which shall not exceed 50 MHz, centred on the carrier frequency, provided that the on-axis e.i.r.p. density at the considered frequency is 50 dB below the maximum on-axis e.i.r.p. density of the signal (within the nominated bandwidth) expressed in dBW/100 kHz.

NOTE 2: In those CEPT countries where VMESs may not transmit in the band 14,25 GHz to 14,50 GHz, the e.i.r.p. limit defined for the band 14,5 GHz to 14,75 GHz shall apply.

The lower limits shall apply at the transition frequency.

In the frequency band 28,0 GHz to 29,0 GHz, for any 20 MHz band within which one or more spurious signals exceeding the above limit of 67 dBpW/100 kHz are present, then the power of each of those spurious signals exceeding the limit shall be added in watts, and the sum shall not exceed 78 dBpW.

- 4) These limits are applicable to the complete VMES equipment, comprising the IME and EME including cabling between the units.

4.2.1.3 Conformance tests

Conformance tests shall be carried out in accordance with clause 6.2.

4.2.2 On-axis spurious radiation for VMES

4.2.2.1 Justification

To limit the level of interference to satellite radio services.

4.2.2.2 Specification

4.2.2.2.1 "Carrier-on" radio state

The following specification applies to the VMES transmitting at e.i.r.p. values up to $EIRP_{max}$.

In the 14,0 GHz to 14,50 GHz band the e.i.r.p. spectral density of the spurious radiation and outside a bandwidth of 5 times the occupied bandwidth centred on the carrier centre frequency shall not exceed 4 - K dBW in any 100 kHz band.

The e.i.r.p. spectral density of the spurious radiation outside the nominated bandwidth and within a bandwidth of 5 times the occupied bandwidth centred on the carrier centre frequency, shall not exceed 18 - K dBW in any 100 kHz band.

Where K is the factor that accounts for a reduction on the on-axis spurious radiation level in case of multiple VMESs operating on the same frequency and the value is given by one the following cases:

- 1) For the case where only one VMES transmits at any one time on a given carrier frequency, the value of K is 0.
- 2) For the case where several VMESs are expected to transmit simultaneously on a given carrier frequency at the same e.i.r.p. then $K = 10 \log(N)$ where N is the maximum number of these VMESs. The value of N shall not be exceeded for more than 0,01 % of the time. The value of N and the operational conditions of the system shall be declared by the applicant.
- 3) For the case where several VMESs are expected to transmit simultaneously on a given carrier frequency at different e.i.r.p. levels then $K = 10 \log(EIRP_{Aggregate}/EIRP)$, where:
 - EIRP is the on-axis e.i.r.p. (Watts) of the VMES within the nominated bandwidth; and
 - $EIRP_{Aggregate}$ is the maximum on-axis aggregate e.i.r.p. (Watts) within the nominated bandwidth of the VMES system towards the satellite;
 - $EIRP_{Aggregate}$ shall not be exceeded for more than 0,01 % of the time.

The value of $EIRP_{Aggregate}$ and the operational conditions of the VMES network shall be declared by the applicant.

NOTE 1: The on-axis spurious radiations, outside the 14,0 GHz to 14,50 GHz band, are indirectly limited by clause 4.2.1.2. Consequently no specification is needed.

NOTE 2: Intermodulation limits inside the band 14,0 GHz to 14,50 GHz are to be determined by system design and are subject to satellite operator specifications.

For VMESs designed to transmit several carriers on different frequencies simultaneously (multicarrier operation), the above limits only apply to each individual carrier when transmitted alone.

4.2.2.2.2 "Carrier-off" and "Emissions-disabled" radio states

In the 14,0 GHz to 14,50 GHz band the e.i.r.p. spectral density of the spurious radiation outside the nominated bandwidth shall not exceed -21 dBW in any 100 kHz band.

4.2.2.3 Conformance tests

Conformance tests shall be carried out in accordance with clause 6.3.

4.2.3 Off-axis e.i.r.p. emission density within the band

The present clause deals with the off-axis e.i.r.p. emission density (co-polarization and cross-polar) within the band 14,0 GHz to 14,50 GHz.

4.2.3.1 Justification

Protection of other satellite (uplink) systems.

4.2.3.2 Specification

The following specifications apply to the VMES transmitting at e.i.r.p. values up to $EIRP_{max}$.

The maximum e.i.r.p. in any 40 kHz band within the nominated bandwidth of the co-polarized component in any direction ϕ degrees from the antenna main beam axis shall not exceed the following limits:

$$33 - 25 \log(\phi + \delta\phi) - H \text{ dBW for } 2,5^\circ \leq \phi + \delta\phi \leq 7,0^\circ;$$

$$+12 - H \text{ dBW for } 7,0^\circ < \phi + \delta\phi \leq 9,2^\circ;$$

$$36 - 25 \log (\phi + \delta\phi) - H \quad \text{dBW for } 9,2^\circ < \phi + \delta\phi \leq 48^\circ;$$

$$- 6 - H \quad \text{dBW for } \phi + \delta\phi > 48^\circ.$$

where:

- ϕ is the angle, in degrees, between the main beam axis and the direction considered; and
- $\delta\phi$ is the pointing error threshold, in degrees, as declared by the applicant (see clause 4.2.5.2).

For VMESs designed to transmit always at EIRP_{max} , H (in dB) is the maximum number of VMESs which may transmit at EIRP_{max} in the same carrier frequency band as declared by the applicant.

For VMESs designed to operate in an FSS network where the e.i.r.p. of each VMES is determined by the ACF and where the ACF is in charge of the compliance of the aggregate e.i.r.p. density with the above mask, H is the margin as declared by the applicant for compliance with the mask when the VMES is transmitting at EIRP_{max} . In the case where the ACF uses the antenna pattern or the off-axis e.i.r.p. density the applicant shall declare the applicable pattern, the value of H shall be set to 0 dB and the VMES e.i.r.p. density shall not exceed the e.i.r.p. density corresponding to the declared pattern. This margin H or this pattern may be a function of the position of the VMES relative to the GSO arc (e.g. in the case of active antennas).

For $\phi > 70^\circ$ the values given above may be increased to $4 - H$ dBW over the range of angles for which the particular feed system may give rise to relatively high levels of spillover.

In addition the maximum e.i.r.p. in any 40 kHz band within the nominated bandwidth of the cross-polarized component in any direction ϕ degrees from the antenna main beam axis shall not exceed the following limits:

$$23 - 25 \log (\phi + \delta\phi) - H \quad \text{dBW for } 2,5^\circ \leq \phi + \delta\phi \leq 7,0^\circ;$$

$$2 - H \quad \text{dBW for } 7,0^\circ < \phi + \delta\phi \leq 9,2^\circ.$$

where ϕ , and H are as defined above.

For non-continuous transmission, the above limits may not apply for a specific portion of each burst as declared by the applicant. This excluded portion shall not exceed 50 μsec or 10 % of the burst, whichever is the smaller.

The excluded portion shall have characteristics similar to the remaining part of the burst:

- same symbol rate and modulation; and
- same or lower maximum amplitude.

NOTE 1: The specification above is intended to take account of the spectrum of the preamble of bursts in TDMA systems.

NOTE 2: The satellite operator may require lower off-axis e.i.r.p. limits in compliance with FSS intersystem coordination agreements. In all cases, off-axis e.i.r.p. emissions are subject to compliance with national regulations and the relevant FSS intersystem coordination agreements.

Any antenna off-axis direction may be defined by a pair of values (α, φ) where φ is the off-axis angle of that direction with the antenna main beam axis and α is the angle of the plane defined by that direction and the antenna main beam axis with any arbitrary plane containing the antenna main beam axis.

The range of values of φ and α is from $\varphi_{\text{min}} - \delta\varphi$ to 180° for φ , and from -180° to $+180^\circ$ for α .

The above limits only apply to any off-axis direction (α, φ) within $\pm 3^\circ$ of the visible part of the GSO. The concerned directions shall be any direction within the (α, φ) domain unless it can be demonstrated by documentary evidence that only a limited subset of the (α, φ) domain is concerned.

The determination of the (α , φ) subset shall take into account the operational conditions for which the VMES is designed, as declared by the applicant or indicated within the user documentation. These conditions shall include:

- the range of latitudes of the VMES; if
- the minimum elevation pointing angle;
- the type of antenna mount (e.g. with azimuth and elevation axes or equatorial);
- the maximum static and dynamic alignment errors of the antenna mount axes;
- the maximum static and dynamic alignment errors of the antenna major axis with respect to the GSO arc;
- the range of adjustment for the major axis of the antenna for antennas with asymmetric main beam;
- the direction of the electric field radiated by the satellite with respect to the Earth's axis, when the electric field is used for the antenna alignment.

The alignment errors shall not exceed the declared maximum values when applying the alignment method declared by the applicant or indicated within the user documentation.

NOTE 3: TR 102 375 [i.3] gives guidance for the determination of the concerned subset within the (α , φ) domain.

4.2.3.3 Conformance tests

Conformance tests shall be carried out in accordance with clause 6.4.1 with the results being computed in accordance with clause 6.4.2.

4.2.4 Carrier suppression

4.2.4.1 Justification

To allow for the satisfactory suppression of transmissions of the VMES by the ACF, under any fault condition and under any cessation of emissions condition.

4.2.4.2 Specification

In the "Carrier-off" and in the "Emissions-disabled" radio states the on-axis e.i.r.p. density shall not exceed 4 dBW in any 100 kHz band within the nominated bandwidth.

4.2.4.3 Conformance tests

Conformance tests shall be carried out in accordance with clause 6.5.

4.2.5 Antenna pointing and polarization alignment for VMESs

4.2.5.1 Justification

Protection of transmissions to adjacent satellites and cross-polarized transponders on the same satellite.

4.2.5.2 Specification

a) Mechanical stability:

- The VMES shall be designed to operate in accordance with the maximum values for the environmental parameters specified in clause 4.1.1.

b) Pointing error detection:

- The VMES shall be able to detect the pointing error. The VMES, when in the "Carrier-on" radio state, shall enter the "Carrier-off" radio state when the instantaneous pointing error exceeds the pointing error threshold, $\delta\phi$, relative to the direction of the wanted satellite at its actual position, within T seconds. The values of $\delta\phi$ and T shall be declared by the applicant and the value of T shall not exceed 2 seconds. The VMES shall not re-enter the "Carrier-on" radio state until the instantaneous pointing error is within $\delta\phi$ for a period of $2 \times T$ seconds.
- The applicant shall declare the maximum time (IT_{\max}) that the VMES can remain in "Transmission-enabled" state and "Carrier-off" radio state (see clause 4.2.8.8). If the pointing error threshold is exceeded for more than IT_{\max} then the VMES shall enter the "Initial phase" state.
- The applicant may declare ranges of values for $\delta\phi$ as functions of on-axis e.i.r.p. spectral density such that the e.i.r.p. density limits in clause 4.2.3.2 are not exceeded.

c) Polarization angle alignment capability:

- The polarization angle shall be adjustable over the range declared by the applicant. For a range lower than 90° , the applicant shall also declare the geographical region (latitude and longitude) relative to the satellite orbital position for which the VMES is designed to operate, taking into account the inclination of the electric field radiated by the satellite.
- The misalignment error, α , of the transmit antenna polarization is the sum of the misalignment errors due to the tracking process plus, for VMESs that set the transmit polarization by tracking the receive polarization, the misalignment error of the transmit polarization plane relative to the receive polarization plane. The misalignment error, α , shall not exceed the maximum polarization misalignment, α_{\max} , declared by the applicant, such that:

$$\alpha_{\max} = \text{ArcTan} \left(\sqrt{\frac{XPD_{\text{antenna}} - XPD_{\text{VMES}}}{XPD_{\text{antenna}} \cdot XPD_{\text{VMES}} - 1}} \right)$$

where:

- XPD_{VMES} is the equivalent cross polarization discrimination (XPD) of the VMES, expressed as a ratio, as declared by the applicant;
- XPD_{antenna} is the antenna XPD at the centre frequency of the transmit band, expressed as a ratio.

NOTE 1: Satellite operators may require specific values for XPD_{VMES} and they may also require the VMES to stop its transmissions (e.g. to enter the "Carrier-off" radio state) if the value falls below XPD_{VMES} .

NOTE 2: The lower bound XPD_{er} of the global XPD of the VMES antenna with a receiving antenna is given by the following formula:

$$XPD_{\text{er}} \geq \frac{1 + XPD_{\text{VMES}} \cdot XPD_r - 2 \cdot \sqrt{XPD_{\text{VMES}}} \cdot \sqrt{XPD_r}}{XPD_{\text{VMES}} + XPD_r + 2 \cdot \sqrt{XPD_{\text{VMES}}} \cdot \sqrt{XPD_r}} = \left(\frac{1 + \sqrt{XPD_{\text{VMES}}} \cdot \sqrt{XPD_r}}{\sqrt{XPD_{\text{VMES}}} + \sqrt{XPD_r}} \right)^2$$

where XPD_r is the XPD of the receiving antenna.

4.2.5.3 Conformance tests

Conformance tests shall be carried out in accordance with clauses 6.7 to 6.9. In addition, clause 6.11.8 contains the conformance test for inhibition of transmission when the outage time exceeds IT_{\max} .

4.2.6 Cessation of emissions of the VMES

4.2.6.1 Justification

For cessation of emissions of the VMES where the VMES is not allowed to transmit.

4.2.6.2 Specification

4.2.6.2.1 Specification 1: Mode of cessation of emissions

At least one of the following two modes of cessation of emissions shall be implemented:

- a) the ACF determines that the VMES must cease emissions; and/or
- b) the VMES autonomously determines that it must cease emissions.

In addition, there shall be a "single-action" means (e.g. operating a switch) by which a local operator may disable the VMES and thereby cease emissions.

The applicant shall declare the VMES interfaces involved in the cessation of emissions:

- the list of relevant parameters which are collected by the VMES or the ACF for determination as to whether the VMES should cease emissions;
- the list of these relevant parameters which are used by the VMES;
- the list of these relevant parameters which are transmitted by the VMES to the ACF;
- the list of the relevant parameters which are received by the VMES from the ACF;
- for the collected relevant parameters, the VMES interface (s), including the protocols, the timing, the ranges of the values, the speed of the variations and the required accuracies;
- for the relevant parameters transmitted to the ACF, the VMES interface with the ACF, including the protocols and the timing;
- for the transmission parameter received from the ACF, the VMES interface with the ACF, including the protocols and the timing;
- these declared VMES interfaces shall be in accordance with the user documentation.

4.2.6.2.2 Specification 2: Conditions under which the VMES must cease emissions

For VMES networks where the ACF determines completely or partially where and under which conditions the emissions of the VMES must be ceased, the collection of the relevant parameters by the VMES and the exchange of information between the VMES and the ACF shall be sufficient for the ACF to determine when to cease emissions with the accuracy declared by the applicant and to inform in time the VMES to cease emissions prior to entering any exclusionary zone.

For VMESs which determine completely where and under which conditions the emissions must be ceased, the collection of the relevant parameters by the VMES shall be sufficient for the VMES to determine when to cease emissions within the accuracy declared by the applicant.

The determination of these conditions shall take into account any inaccuracy in determination of the VMES geographic location and of the boundaries of the authorized operating areas in the data base used either by the VMES or the ACF, as declared by applicant.

The conditions for cessation of emissions shall take into account at least the following parameters:

- the location of the VMES and the boundaries of the authorized operating area;
- the operating parameters specified in clauses 4.2.1 through 4.2.6;

- the carrier frequency and the authorized frequency bands.

4.2.6.2.3 Specification 3: Cessation of emissions

A condition requiring cessation of emissions occurs either when the VMES receives the command from the ACF at its input or when the VMES determines autonomously on the need to cease emissions.

When in the "Transmission-enabled" state a condition requiring cessation of emissions occurs, the VMES shall cease transmissions and enter the "Initial Phase" state.

When in the "Transmission-disabled" state, the VMES shall not leave that state for the "Transmission-enabled" state as long as a condition requiring cessation of emissions exists or the last CC command received from the ACF is a transmission disable command.

When in the "Initial phase-BurstOn" or "Initial phase-BurstOff" substate a condition requiring cessation of emissions occurs, the VMES shall cease transmissions and enter the "Initial phase-Standby" substate.

When in the "Initial phase-Standby" substate, the VMES shall not leave that state for the "Initial phase-BurstOn" or the "Transmission-enabled" states as long as a condition requiring cessation of emissions exists.

The time for transition in any state from the occurrence of a condition requiring cessation of emissions to the "Emissions-disabled" radio state shall not exceed 1 second.

4.2.6.2.4 Specification 4: Fault conditions

Any collection of the relevant parameters by the VMES or transmission of these parameters to the ACF, which have not been completed correctly within the required delay(s) as declared by the applicant, shall be considered as a fault condition.

Any transmission parameter not received or not correctly received from the ACF within the required delay declared by the applicant shall be considered as a fault condition.

These fault conditions shall be processed as conditions requiring cessation of emissions.

4.2.6.3 Conformance tests

Conformance tests shall be carried out in accordance with clause 6.9.

4.2.7 Identification of the VMES

4.2.7.1 Justification

To fulfil the requirements for identification of individual VMES units whether operated in a point-to-point fashion or in a network and for potential use by duly authorized entities.

4.2.7.2 Specification

The VMES shall be designed such that it is possible for the operator to identify which VMESs are transmitting with at least 100 m resolution in a given geographic area. The applicant shall declare the means by which identification of VMESs is accomplished. In the case where an external system is required, the applicant must declare which additional means are necessary for identification of the VMES.

4.2.7.3 Conformance tests

Conformance tests shall be carried out in accordance with clause 6.10.

4.2.8 Control and Monitoring Functions (CMFs)

4.2.8.1 CMF state diagram

The following minimum set of CMFs shall be implemented in VMESs in order to minimize the probability that they originate unwanted transmissions that may give rise to harmful interference to other systems.

In the "Non-valid" state and in the "Transmission-disabled" state the VMES shall not transmit. In the "Transmission-enabled" state the VMES is allowed to transmit. In the "Initial phase" state the VMES is only allowed to transmit initial bursts.

NOTE 1: The restrictions in the "Initial phase" state are for the protection of other systems when the VMES is entering the system after a power-on or a reset. These initial burst restrictions do not apply to the VMES transmissions in the "Transmission-enabled" state and once a transmission enable command has been received by the VMES the VMES may transmit or not transmit as required.

Under any fault condition the VMES shall enter the "Non-valid" state where the e.i.r.p. limits for the "Emissions-disabled" radio state apply.

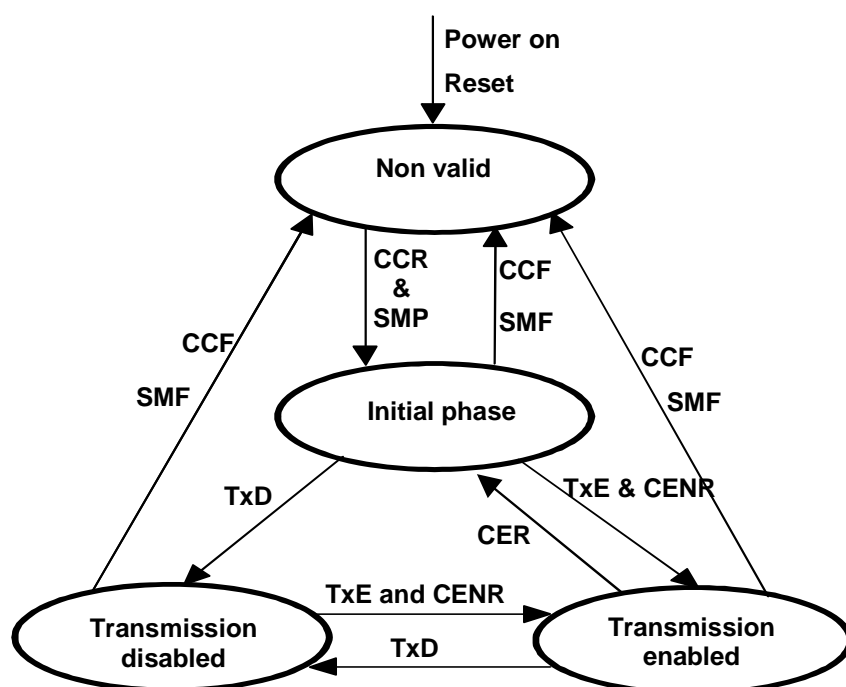

CER: Cessation of Emissions Required;
 CENR: Cessation of Emissions Not Required;
 SMP: System Monitoring Pass;
 SMF: System Monitoring Fail;
 TxE: Transmission Enable command;
 TxD: Transmission Disable command;
 CCR: Control Channel correctly Received;
 CCF: Control Channel reception Failure.

Figure 2: State transition diagram of the control and monitoring function of a VMES

NOTE 2: From "Transmission-disabled" state a TxE command may also result in a transition towards the "Initial phase" state.

When the VMES transmits several carriers having different frequencies, a VMES state machine as described above may be associated with each carrier or each set of carriers. The events then apply to the subsystem associated with the specific carrier or the specific set of carriers, rather than the whole VMES.

4.2.8.2 Processor monitoring

4.2.8.2.1 Justification

To ensure that the VMES can suppress its transmissions in the event of a processor sub-system failure.

4.2.8.2.2 Specification

The VMES shall incorporate a processor monitoring function for each of its processors involved in maintaining the performance requirements of the present document and in Control and Monitoring Functions (CMF).

The processor monitoring function shall detect failures of these processors' hardware and software.

In the "Transmission-enabled" state, the VMES shall enter the "Non-valid" state or the "Carrier-off" radio state no later than 1 second after any fault condition occurs, and in any case it shall enter the "Non-valid" state within 30 seconds until the processor monitoring function has determined that all fault conditions have been cleared. In any other state after any fault condition occurs, the VMES shall enter the "Non-valid" state within 30 seconds until the processor monitoring function has determined that all fault conditions have been cleared.

4.2.8.2.3 Conformance tests

Conformance tests shall be carried out in accordance with clause 6.11.2.

4.2.8.3 Transmit subsystem monitoring

4.2.8.3.1 Justification

To ensure the inhibition of transmissions that are potentially harmful to other systems in the event of incorrect operation of the transmit frequency generation sub-system.

4.2.8.3.2 Specification

The VMES shall monitor the operation of its transmit frequency generation sub-system and shall be able to detect:

- a) loss of frequency lock;
- b) absence of Local Oscillator (LO) output signal.

No later than 1 second after any of these fault conditions of the transmit frequency generation sub-system occurs, the VMES shall enter the "Non-valid" state until the transmit sub-system monitoring function has determined that all fault conditions have been cleared.

4.2.8.3.3 Conformance tests

Conformance tests shall be carried out in accordance with clause 6.11.3.

4.2.8.4 Power-on/Reset

4.2.8.4.1 Justification

To demonstrate that the VMES achieves a controlled non-transmitting state following the powering of the unit, or the occurrence of a reset made by a local operator when this function is implemented.

4.2.8.4.2 Specification

Following a manual reset, when this function is implemented, the VMES shall enter the "Non-valid" state.

During and following "power-on" the VMES shall remain in the "Non-valid" state until all the conditions for entering "Initial phase" have been satisfied.

4.2.8.4.3 Conformance tests

Conformance tests shall be carried out in accordance with clause 6.11.4.

4.2.8.5 Control Channel (CC) and Response Channel (RC)

4.2.8.5.1 Justification

Control Channels (CC) are used by VMESs to receive control information from the ACF and Response Channels (RCs) to respond to the ACF. For VMES designed to operate within networks where the ACF determines that the VMES must cease emissions, then the CCs and RCs are also used for the dialogue with the ACF.

To ensure that the VMES cannot transmit unless it correctly receives the CC messages from the ACF.

4.2.8.5.2 Specification

4.2.8.5.2.1 Specification 1: types of CCs and RCs

- a) The VMES shall have at least one CC from the ACF. If exchange of information with the ACF is necessary for operation of the VMES then the VMES shall have at least one RC to the ACF (see clause 4.2.6). Each CC and each RC may be internal or external.

The types (internal or external) of each CC and each RC shall be declared by the applicant.

NOTE 1: The availability of the network carrying the external CC(s) and RC(s) and the numbers of external CC(s) and RC(s) are not within the scope of the present document.

NOTE 2: Some satellite operators may require that internal CC(s) and or RC(s) are available.

- b) The connection between the ACF and the VMES via the CCs and RCs shall be either permanent or shall be set up on a call by call basis through a switched network. In case of connection through a switched network the VMES shall be able to receive calls from the ACF and to initiate calls towards the ACF in order to set up the CCs and RCs.
- c) The VMES with an external CC shall not transmit without receiving an appropriate signal from the ACF through the satellite to which the VMES transmits, indicating to the VMES that the ACF is alive and insuring that the VMES is pointing to the target satellite.

4.2.8.5.2.2 Specification 2: CC Reception

- a) The VMES shall enter the "Non-valid" state immediately after a period not exceeding 30 seconds without correct reception of the CC from the ACF, i.e. without being able to receive CC messages from the ACF. This event is called a "CC disruption".
 - In the case of external CCs and RCs without permanent connection of the ACF with the VMES, the ability to receive CC messages from the ACF is the ability at any time to receive calls and messages within the timing requirements of the present document from the network through which is connected the ACF.
 - The inability to receive CC messages from the ACF may be due to the following various causes but not limited to them: no received signal from the ACF or from the network, a too low level received signal, no network accessible, the inability to lock onto the received carrier frequency, to demodulate, to decode, to receive calls and/or messages, a hardware failure or power off.
- b) The VMES shall remain in the "Non-valid" state as long as the VMES is unable to receive CC messages from the ACF.
- c) From the "Non-valid" state the VMES may enter the "Initial phase" state if the following conditions are met:
 - the VMES is able to receive CC messages from the ACF; and
 - no fault conditions are present.

4.2.8.5.3 Conformance tests

Conformance tests shall be carried out in accordance with clause 6.11.5.

4.2.8.6 Network control commands

4.2.8.6.1 Justification

These requirements ensure that the VMES is capable of:

- a) retaining a unique identification in the network;
- b) receiving commands from the ACF through its CC(s) and executing those commands.

4.2.8.6.2 Specification

The VMES shall hold, in non-volatile memory, its unique identification code in the network.

The VMES shall be capable of receiving through its CCs dedicated messages (addressed to the VMES) from the ACF, and which contain:

- Transmission Enable commands (TxE);
- Transmission Disable commands (TxD).

When in the "Initial phase" or "Transmission-enabled" states, once a transmission disable command is received, within 1 second the VMES shall enter into, and shall remain in the "Transmission-disabled" state until the transmission disable command is superseded by a subsequent transmission enable command (see also clause 4.2.6).

When in the "Initial phase" or "Transmission-disabled" states, once a transmission enable command is received, the VMES may enter into the "Transmission-enabled" state.

When entering the "Initial phase" from the "Non-valid" state, the last TxE or TxD command received from the ACF may be used by the VMES to enter the "Transmission-enabled" state or the "Transmission-disabled" state, respectively, if since the time of reception of that command no "CC disruption" occurred.

NOTE: The physical unit in charge of the reception of the CCs, of the transmissions of the RCs and of the CC commands reception may be a separate and independent unit from the other units of the VMES and it may be common to several VMESs.

4.2.8.6.3 Conformance tests

Conformance tests shall be carried out in accordance with clause 6.11.6.

4.2.8.7 Initial burst transmission

4.2.8.7.1 Justification

Restrictions on the initial burst transmissions are necessary to limit disturbance to other services.

4.2.8.7.2 Specification

For systems where no transmission enable command is foreseen without request from the VMES, in the "Initial phase" state the VMES may transmit initial bursts:

- a) The VMES shall not start the transmission of initial bursts before having obtained a confirmation that no cessation of emission applies where the VMES is located. This confirmation shall be obtained either by local means of determination of the cessation of emissions (see clause 4.2.6) or from the ACF via an external control channel.
- b) The duty cycle of the burst retransmission shall not exceed 0,2 %, where the duty cycle is defined as the ratio of burst duration to the duration between two successive bursts.

- c) Each burst shall not carry more than the minimum number of data bytes excluding the burst preambles and the FEC coding bits necessary to establish synchronization.
- d) The initial burst shall be transmitted at an e.i.r.p. no greater than $EIRP_{max}$.
- e) The duration between two successive bursts shall not be less than the required ACF response time as declared by the applicant. This response time is defined as the duration, measured at the VMES, between an initial burst transmission and the reception and processing of a transmission enable or disable command from the ACF which is never exceeded during 99 % of the cases under normal conditions in the system for which the VMES is designed, as declared by the applicant.

4.2.8.7.3 Conformance tests

Conformance tests shall be carried out in accordance with clause 6.11.7.

4.2.8.8 Inhibition of transmissions

4.2.8.8.1 Justification

To ensure the correct inhibition of transmissions that are potentially harmful to other systems and persons in the event of signal blockage.

4.2.8.8.2 Specification

The VMES shall inhibit transmissions whenever there is a loss of receive carrier (e.g. synchronization or signal level).

VMES shall enter the "Carrier-off" radio state within a period not exceeding 0,5 seconds, when these conditions persist during that period, and shall remain in this radio state until the receiver carrier has been restored.

The applicant shall declare the maximum outage time (IT_{max}) for this condition ("Transmission-enabled" state and "Carrier-off" radio state). If the receive carrier is not restored within IT_{max} , then the VMES shall transition to the "Initial phase" state.

The applicant shall declare the time to transition from "Carrier-off" to "Carrier-on" radio state (IT_{trans}) when in "Transmission-enabled" state after the receive carrier is restored within IT_{max} .

4.2.8.8.3 Conformance tests

Conformance tests shall be carried out in accordance with clause 6.11.8.

5 Testing for compliance with technical requirements

5.1 Environmental conditions for testing

Survivability testing shall be carried out prior to tests on the radiation and stabilization subsystems.

Tests defined in the present document shall be carried out at representative points within the boundary limits of the declared operational environmental profile.

5.2 Essential radio test suites

The essential radio test suites for a complete VMES are given in clause 6.

6 Test methods for all aspects of the VMES

6.1 General

The present clause describes the general requirements for verifying that the performance of the EUT complies with the specifications. However, the specific testing methodology to be used for measuring performance is left to the applicant in order to allow the methodology to be matched to the EUT. The applicant shall maintain documentary evidence of the results obtained in performing the essential radio tests. At a minimum, the documentary evidence shall include:

- test setup (configurations, test equipment and calibration status);
- test conditions (environmental and operational parameters);
- method of testing;
- results of measurements, measurement resolution and uncertainty; and
- statement of compliance with technical specifications of the present document.

The test conditions for each test shall be representative of the intended operational environment and be noted in the test report where it has a significant effect on the measurement results.

The type, termination and length of each cable used shall be representative of the intended installation and recorded in the test report. For maximum cable lengths longer than 10 m, as declared by the applicant, the tests shall be performed with cables no shorter than 10 m.

TR 102 215 [i.4] provides a recommended approach to measurement uncertainty and interpretation of results. Where the measurement approach does not conform to the guidance in TR 102 215 [i.4], the applicant shall declare the method of measurement and the uncertainty achieved under this method.

The test site and the method of measurement shall also be in accordance with CISPR 16-1-5 [3] as applicable.

Where a radome is required in operation, the tests should be conducted with the radome in place or, if testing with the radome in place is impractical, then an appropriate analytic technique shall be used to compensate for the absence of the radome.

To enable the performance tests to be carried out the use of an ACF or a Special Test Equipment (STE), made available by the applicant or system provider, may be necessary. Since this STE will be specific for the particular system, it is not possible to provide detailed specifications in the present document. However, the following baseline is provided:

- if the VMES requires to receive a modulated carrier from the satellite in order to transmit, then special test arrangements are required to simulate the satellite signal, thus enabling the VMES to transmit allowing measurement of transmission parameters;
- any characteristic of these special test arrangements which may have direct or indirect effects on the parameters to be measured shall be clearly stated by the applicant.

All tests with carrier-on shall be undertaken with the transmitter operating at $EIRP_{max}$, as per the specific requirement, and with the normal radio operating parameters, as declared by the applicant.

If the Equipment Under Test (EUT) is a VMES that requires hardware and/or software modification(s) performed by the applicant for these tests then full documentation of such modification(s) shall be provided to demonstrate that the modification(s) will simulate the required test condition, without its main characteristics being changed.

6.2 Off-axis spurious radiation

The tests for the VMES specification in clause 4.2.1.2 shall be conducted in "Carrier-on", "Carrier-off" and "Emissions-disabled" radio states as required. The tests in "Carrier-on" radio state shall be undertaken with the transmitter operating at $EIRP_{max}$.

6.2.1 Test method

The applicant shall declare the test methods used to identify frequencies of off-axis spurious radiation and to measure (or calculate) the radiated power levels of identified spurious radiations.

NOTE: For the purposes of this procedure, the measuring antenna is aligned in the polarization which produces the largest response between the EUT and the measuring antenna.

6.3 On-axis spurious radiation

The tests for the VMES specification in clause 4.2.2.2 shall be conducted in "Carrier-on", "Carrier-off" and "Emissions-disabled" radio states as required.

The tests in "Carrier-on" radio state shall be undertaken with the transmitter operating at $EIRP_{max}$. Test measurements shall be made at least three points within the operating band including: locating the carrier at the centre frequency of the operating band; as close to the lower operating frequency limit as possible; and as close to the upper operating frequency limit as possible.

6.3.1 Test method

The applicant shall declare the test methods used to identify frequencies of on-axis spurious radiation and to measure (or calculate) the radiated power levels of identified spurious radiations.

NOTE: For the purposes of this procedure, the measuring antenna is aligned in the polarization which produces the largest response between the EUT and the measuring antenna.

6.4 Off-axis e.i.r.p. emission density within the band

The tests for the VMES specification in clause 4.2.3.2 for off-axis e.i.r.p. emission density (co-polarization and cross-polarization) within the band 14,0 GHz to 14,50 GHz shall be conducted in the "Carrier-on" radio state. The tests shall be undertaken with the transmitter operating at $EIRP_{max}$.

The applicant shall declare the elevation angle within the range of applicable angles, with respect to the local horizon, at which the worst case radiation pattern performance and losses occur and tests shall be carried out at this elevation angle.

The tests in "Carrier-on" radio state shall be undertaken with the transmitter operating at $EIRP_{max}$. Test measurements shall be made at least three points within the operating band including: locating the carrier at the centre frequency of the operating band; as close to the lower operating frequency limit as possible; and as close to the upper operating frequency limit as possible.

6.4.1 Test method

6.4.1.1 General

The applicant shall declare the test methods used to identify frequencies of off-axis radiation and to measure (or calculate) the radiated emission power density levels within the band.

NOTE: For the purposes of this procedure, the measuring antenna is aligned in the polarization which produces the largest response between the EUT and the measuring antenna.

The measurement shall be made in the operational configuration(s) (including occupied bandwidth, $EIRP_{max}$) producing the highest emission density in the frequency band. The selected configuration(s) shall be recorded in the test report.

If the test is to be carried out with an STE, then the STE shall provide all the signals needed by the VMESs under normal operation (e.g. a radio beacon if it is expected to be received by the satellite).

The e.i.r.p. densities are determined from the measurements of the antenna copolarization and crosspolarization gain patterns, and of the power density at the antenna flange. These e.i.r.p. densities shall be compared to the specified masks of clause 4.2.3.2.

To ascertain the off-axis e.i.r.p. it is necessary to know the transmit power density and antenna transmit radiation pattern. To ascertain the radiation pattern it is necessary to know the antenna transmit gain.

The following three measurement procedures shall, therefore, be performed:

- a) transmit output power density (dBW/40 kHz);
- b) antenna transmit gain (dBi);
- c) antenna transmit radiation patterns (dBi).

6.4.1.2 Transmit output power density

The EUT output power shall be set to the power corresponding to $EIRP_{max}$. The measurements shall be made in the operational configuration(s) producing the highest emission density in the frequency band. The selected configuration(s) shall be recorded in the test report.

6.4.1.3 Antenna transmit gain

For the purpose of the present document, the antenna transmit gain is defined as the ratio, expressed in decibels (dBi), of the power that would have to be supplied to an isotropic radiator isolated in space, to the power supplied to the antenna being considered, so that they produce the same field strength at the same distance in the same direction. Unless otherwise specified the transmit gain is for the direction of maximum radiation (i.e. peak transmit gain).

This test is normally performed with the antenna removed and the measurements made at the antenna flange. For an EUT where the antenna is integrated within the unit, the applicant shall declare the test method to be used to derive the antenna transmit gain.

6.4.1.4 Antenna transmit radiation patterns

For the purpose of the present document, the antenna transmit radiation patterns are diagrams relating field strength to the angle of the direction pointed by the antenna at a constant large distance from the antenna (in the far field of the antenna).

NOTE: Near field measurements may also be used if the appropriate correction factors can be applied. The applicant should declare the method used for these measurements and justification for adopting this method for these particular measurements.

Tests shall be performed and the results recorded for co- and cross-polarization antenna transmit radiation patterns and in the elevation and azimuth planes, with the antenna radiating through its radome at the minimum elevation angle as declared by the applicant. The co-polarization transmit pattern measurement shall be performed in azimuth from -180° to $+180^\circ$ with respect to the antenna mechanical boresight and from -15° to $+90^\circ$ in elevation with respect to the antenna mechanical boresight, with the results recorded. The cross-polarization transmit pattern measurement shall be performed in azimuth from -10° to $+10^\circ$ and from -1° to $+10^\circ$ in elevation with the results recorded. In the case of antennas where the sidelobes vary as a function of the elevation angle, the elevation transmit radiation pattern measurements shall be made with the antenna set to the elevation angle that produces the maximum sidelobe level.

6.4.2 Computation of results

The results shall be computed by producing a "mask" to the specified limits with the reference level being equal to the sum of the transmitter output power density and the gain of the antenna. This reference shall then be placed on the maximum point of the plots obtained from the transmit radiation pattern measurements, so as to ascertain that the off-axis e.i.r.p. density is within the mask, and thus conforming to the specification in clause 4.2.3.

6.5 Carrier suppression

6.5.1 Test method

For the purposes of this test, the EUT shall transmit one carrier modulated continuously, or at its maximum burst rate where applicable, centred on the middle frequency of the operating frequency band as declared by the applicant. The "transmission-disabled state" shall be obtained by use of the ACF or an STE, if required. For conducted measurements the maximum residual carrier power density within the nominated bandwidth shall be measured and added to the antenna on-axis gain. For radiated measurements the maximum residual e.i.r.p. density within the nominated bandwidth shall be measured and recorded. If the results obtained are within the limit given in clause 4.2.4.2, then the EUT shall be declared compliant with the requirements.

6.6 Antenna pointing for VMES

6.6.1 General

The antenna pointing test method is designed to verify the ability of the EUT to detect and correctly respond to pointing errors that exceed the threshold, $\delta\phi$, declared by the applicant as required in clauses 4.2.3 and 4.2.5.

For the purpose of these tests the EUT is the VMES with its antenna connected.

6.6.2 Test method

There shall be a means for measuring and analyzing true pointing error values declared by the applicant. The means of measuring and analyzing pointing errors shall be included in the test report.

There shall be a means of dynamically inducing pointing errors that exceed the threshold declared by the applicant. The means for inducing pointing errors shall be representative of actual operating vehicle dynamics, within the dynamic limits declared by the applicant. If dynamic means alone are not sufficient to induce pointing errors that exceed the threshold for pointing errors, then an alternative means shall be used. Pointing errors shall be induced in at least two orthogonal directions; but not necessarily during the same test sequence. The means of inducing pointing errors shall be included in the test report.

It shall be verified that the EUT correctly detects that the induced pointing error has exceeded the pointing error threshold and enters the "Carrier-off" radio state no later than T seconds after the pointing error threshold is exceeded, where T is the response time declared by the applicant.

After the pointing error has been decreased below the pointing error threshold, it shall be verified that the EUT does not re-enter the "Carrier-on" radio state for at least $2 \times T$ seconds.

The tests shall be repeated a number of times to ensure reliability of pointing error detection and appropriate response.

6.7 Antenna mechanical stability

6.7.1 Test method

The applicant shall declare the methodology used to test and verify compliance with the requirements for mechanical stability, see clause 4.2.5.

The methodology described in annex B may be used to show compliance with the specification for mechanical stability.

6.8 Polarization angle alignment capability

The polarization angle alignment test method is designed to verify the ability of the EUT to detect and correct polarization alignment errors as required in specification c) of clause 4.2.5.2.

For the purpose of these tests the EUT is the VMES with its antenna connected.

6.8.1 Test method

The polarization angle adjustment facilities shall be examined to determine both the angular movement possible and the means of establishing and fixing the alignment.

There shall be a means for measuring and analyzing true Polarization Angle Misalignment Error (PAME) values against the maximum PAME as declared by the applicant. The means of measuring and analyzing PAME shall be included in the test report.

There shall be a means of dynamically inducing PAME that exceed the threshold declared by the applicant. The means for inducing PAME shall be representative of actual operating vehicle dynamics, within the dynamic limits declared by the applicant. If dynamic means alone are not sufficient to induce PAME that exceed the threshold for PAME, then an alternative means shall be used.

It shall be verified that the EUT correctly detects that the induced PAME has exceeded the PAME threshold and enters the "Carrier-off" radio state no later than T seconds after the PAME threshold is exceeded, where T is the response time declared by the applicant.

After the PAME has been decreased below the PAME threshold, it shall be verified that the EUT does not re-enter the "Carrier-on" radio state for at least $2 \times T$ seconds.

The tests shall be repeated a minimum of three times to ensure reliability of PAME detection and appropriate response.

6.9 Cessation of emissions of the VMES

There shall be a means of simulating a condition where cessation of emissions is required. The spectrum analyser or the oscilloscope may be used to measure the time difference between the occurrence of the condition and the cessation of emissions. In all test methods, it shall be verified that the time difference does not exceed 1 second as specified in clause 4.2.6.2.3.

Where the EUT adds an operational margin around areas where cessation of emissions is required to account for the position determination accuracy and latency, the test procedure may simulate the actual behaviour of an EUT as it enters into an area where cessation of emissions is required. For example, if the EUT adds a margin of X metres around areas where cessation of emissions is required, then the test may begin with the EUT being simulated at a position more than X metres outside of an area where cessation of emissions is required. The test may then simulate the motion of the EUT towards the area where cessation of emissions is required. In any event, the EUT shall enter the "emission disabled" radio state within 1 second of entering the actual area where cessation of emissions is required.

For the purpose of these tests the EUT is the VMES either with, or without its antenna connected.

6.9.1 Test Method

6.9.1.1 Required documentation

The applicant shall declare the mode(s) of cessation of emissions implemented in the EUT and the VMES interfaces involved in the cessation of emissions as specified in clause 4.2.6.2.1.

The applicant shall demonstrate by documentary evidence compliance with specification 2 in clause 4.2.6.2.2 for the determination of the conditions under which the VMES must cease emissions.

6.9.1.2 Cessation of emissions from the "Transmission-enabled" state

- a) The EUT shall be set in the "Transmission-enabled" VMES state.
- b) The EUT shall be set in the "Carrier-on" radio state.
- c) A condition requiring the cessation of emission shall be initiated either by the STE or the EUT.
- d) It shall be verified that the EUT enters the "Emissions-disabled" radio state.
- e) In order to verify that the EUT is in the "Transmission-disabled" VMES state, it shall be verified that the EUT remains in the "Emissions-disabled" radio state when the EUT is requested to transmit data.

6.9.1.3 Cessation of emission from the "Transmission-disabled" state

- a) The EUT shall be set in the "Transmission-disabled" state.
- b) A condition requiring the cessation of emission shall be initiated either by the STE or the EUT.
- c) In order to verify that the EUT remains in the "Transmission-disabled" VMES state, it shall be verified that the EUT remains in the "Emissions-disabled" radio state when the EUT is requested to transmit data.
- d) The STE shall send a TxE command to the EUT.
- e) In order to verify that the EUT remains in the "Transmission-disabled" VMES state, it shall be verified that the EUT remains in the "Emissions-disabled" radio state when the EUT is requested to transmit data.
- f) The STE shall send a TxD command to the EUT.
- g) The condition requiring the cessation of emissions shall be removed.
- h) In order to verify that the EUT remains in the "Transmission-disabled" VMES state, it shall be verified that the EUT remains in the "Emissions-disabled" radio state when the EUT is requested to transmit data.

6.9.1.4 Cessation of emission from the "Initial Phase" state

6.9.1.4.1 EUTs transmitting initial bursts

This applies only to EUTs transmitting initial bursts (i.e. where "Initial phase-BurstOn" and "Initial phase-BurstOff" are implemented).

- a) The EUT shall be set in "Initial phase-BurstOn" state.
- b) The STE shall not send the TxE command and the EUT shall be allowed to cycle between "Initial phase-BurstOn" and "Initial phase-BurstOff" as it would under normal operations.
- c) A condition requiring the cessation of emission shall be initiated either by the STE or the EUT.
- d) It shall be verified that the EUT enters the "Emissions-disabled" radio state.
- e) In order to verify that the EUT is in the "Initial phase-Standby" VMES state, it shall be verified that the EUT remains in the "Emissions-disabled" radio state when the EUT is requested to transmit data.
- f) The STE shall send a TxE command to the EUT.
- g) In order to verify that the EUT remains in the "Initial phase-Standby" VMES state or enters the "Transmission-disabled" VMES state, it shall be verified that the EUT remains in the "Emissions-disabled" radio state when the EUT is requested to transmit data.
- h) Repeat the test steps a) through g) using a TxD command in step f) instead of the TxE command.

6.9.1.4.2 EUTs not transmitting initial bursts

This applies only to EUTs that do not transmit initial bursts (i.e. where only "Initial phase-Standby" is implemented).

- a) The EUT shall be set in "Initial phase-Standby" VMES state.
- b) The STE shall not send the TxE command to maintain the EUT in "Initial phase-Standby" VMES state.
- c) A condition requiring the cessation of emission shall be initiated either by the STE or the EUT.
- d) In order to verify that the EUT remains in the "Initial phase-Standby" VMES state, it shall be verified that the EUT remains in the "Emissions-disabled" radio state when the EUT is requested to transmit data.
- e) The STE shall send a TxE command to the EUT.

- f) In order to verify that the EUT remains in the "Initial phase-Standby" VMES state or enters the "Transmission-disabled" VMES state, it shall be verified that the EUT remains in the "Emissions-disabled" radio state when the EUT is requested to transmit data.
- g) Repeat the test steps a) through f) using a TxD command in step e) instead of the TxE command.

6.9.1.5 "Single action" means of cessation of emissions

- a) It shall be verified that there is a "single action" means of ceasing emissions of the EUT (e.g. the switch thrown).
- b) The EUT shall be set in the "Transmission-enabled" VMES state.
- c) The EUT shall be set in the "Carrier-on" radio state.
- d) The "single action" means of cessation of emissions shall be activated.
- e) It shall be verified that the EUT enters the "Emissions-disabled" radio state.
- f) In order to verify that the EUT is in the "Transmission-disabled" VMES state, it shall be verified that the EUT remains in the "Emissions-disabled" radio state when the EUT is requested to transmit data.
- g) The STE shall send a TxE command to the EUT.
- h) In order to verify that the EUT remains in the "Transmission-disabled" VMES state, it shall be verified that the EUT remains in the "Emissions-disabled" radio state when the EUT is requested to transmit data.
- i) The EUT shall be switched off and then switched on and the EUT shall enter the "Initial phase" VMES state without receiving a TxE from the STE.
- j) The "single action" means of cessation of emissions shall be activated.
- k) The STE shall send a TxE command to the EUT.
- l) In order to verify that the EUT remains in the "Initial phase" VMES state or enters the "Transmission-disabled" VMES state, it shall be verified that the EUT remains in the "Emissions-disabled" radio state when the EUT is requested to transmit data.
- m) The EUT shall be switched off and then switched on and the EUT shall enter the "Initial phase" VMES state without receiving a TxE from the STE.
- n) The STE shall send a TxD command to the EUT so that it enters the "Transmission-disabled" VMES state.
- o) The "single action" means of cessation of emissions shall be activated.
- p) The STE shall send a TxE command to the EUT.
- q) In order to verify that the EUT remains in the "Transmission-disabled" VMES state, it shall be verified that the EUT remains in the "Emissions-disabled" radio state when the EUT is requested to transmit data.

6.9.1.6 Fault conditions

The applicant shall declare the means of generating fault conditions.

- a) The EUT shall be set in the "Transmission-enabled" VMES state.
- b) The EUT shall be set in the "Carrier-on" radio state.
- c) A fault condition requiring the cessation of emission shall be generated either by the STE or directly on the EUT.
- d) It shall be verified that the EUT enters the "Emissions-disabled" radio state as long as the fault condition persists.
- e) Steps a) through d) shall be repeated for each fault condition declared by applicant.

6.10 Identification of VMES

6.10.1 Test arrangement

The test shall be arranged such that EUT can determine its own location, or if external means are employed, the test shall be arranged so that the EUT can be located by the means declared by the applicant. The STE shall be arranged to simulate the ACF. The actual location of the EME shall be known within the resolution required in clause 4.2.7.2.

6.10.2 Test method

- a) The EUT shall be in the "Transmission-enabled" state.
- b) The EUT shall report its location to the STE.
- c) The difference between the reported EUT location and actual location of the EUT (as simulated in the test) shall be within twice the resolution required in clause 4.2.7.2.

6.11 Control and monitoring functions

The applicant may modify a VMES for the purpose of these tests provided that full documentation is given to prove that the modifications accurately simulate the required test conditions.

The EUT shall transmit at $EIRP_{max}$.

For the purpose of these tests the EUT is the VMES either with, or without its antenna connected.

The measurement of the e.i.r.p. spectral density shall be limited within either the nominated bandwidth or to a 10 MHz bandwidth centred on the carrier frequency, whichever is the greater.

6.11.1 Test arrangement

The EUT shall be authorized to transmit and shall be in the "Transmission-enabled" state at the commencement of each test, unless otherwise stated. The time difference between the command, or failure, and the occurrence of the expected event (e.g. the transmission suppression) shall be measured and recorded.

6.11.2 Processor monitoring- Test method

- a) Each of the processors within the EUT shall, in turn, be caused to fail.
- b) Within 1 second of such failure the EUT shall cease to transmit.
- c) It shall be confirmed that the transmissions have been suppressed within the limits of the "Carrier-off" radio state emission levels.
- d) Within 30 seconds of such failure it shall be confirmed that the transmissions have been suppressed within the limits of the "Emissions-disabled" radio state emission levels.
- e) The failed processor shall be restored to normal working condition and the EUT shall restore automatically to normal working before the next processor shall be induced to fail.

6.11.3 Transmit subsystem monitoring-Test method

- a) The frequency generation subsystem within the EUT shall be caused to fail in respect of:
 - loss of frequency lock (if applicable);
 - absence of Local Oscillator (LO) output signal.
- b) Recognition of each failure in turn by the subsystem monitor shall constitute an SMF event.

- c) Within 1 second of such failure the EUT shall cease to transmit.
- d) It shall be observed that the transmissions have been suppressed within the limits of the "Emissions-disabled" radio state emission levels.
- e) The failed elements shall be restored to normal working state and the EUT shall be restored to normal working condition before the next induced failure.

6.11.4 Power-on/Reset-Test method

- a) The EUT shall be switched off and the STE shall not transmit the CC.
- b) The EUT shall be switched on.
- c) The EUT shall not transmit during and after switching-on, and shall enter the "Non-valid" state.

If a manual reset function is implemented the following test shall be performed:

- d) The EUT shall be restored to the "Initial phase" state and the STE shall transmit the CC.
- e) The EUT shall remain in the "Initial phase" state.
- f) The reset function shall be initiated.
- g) The EUT shall enter the "Non-valid" state.
- h) The EUT shall be restored to the "Initial phase" state and the STE shall transmit the CC as well as a TxE.
- i) The EUT shall enter the "Transmission-enabled" state.
- j) The reset function shall be initiated.
- k) The EUT shall enter the "Non-valid" state.

6.11.5 Control Channel and Response Channel -Test method

For the purposes of these test, the period without correct reception of the CC (T1) shall be as specified in clause 4.2.8.5.2.2.

These test procedures require simulation of the following events:

- The CC has never been received by the EUT after power-on.
 - The CC is lost by the EUT after reception of a Transmission Enable command.
 - The CC is lost by the EUT without reception of a Transmission Enable command.
 - The CC is being lost by the EUT and a call is initiated within the period T1.
- a) Case where the CC has never been received by the EUT after power-on:
 - a1) the EUT shall be switched off and the STE shall not transmit the CC;
 - a2) the EUT shall be switched on;
 - a3) the EUT shall remain in the "Non-valid" state.
 - b) Case where the CC is lost by the EUT after reception of a Transmission Enable command:
 - b1) the EUT shall be switched-on and the STE shall transmit the CC and a Transmission Enable command;
 - b2) the EUT shall enter the "Initial phase" state and go, if applicable, to the "Transmission-enabled" state;
 - b3) a transmission request shall be initiated from the EUT;
 - b4) the STE shall stop transmitting the CC;

- b5) within the period T1 from event b4), the EUT shall enter the "Non-valid" state.
- c) Case where the CC is lost by the EUT without reception of a Transmission Enable command:
 - c1) the EUT shall be switched on and the STE shall transmit the CC;
 - c2) the EUT shall enter the "Initial phase" state;
 - c3) the STE shall stop transmitting the CC;
 - c4) the EUT shall enter in the "Non-valid" state not later than T1;
 - c5) a transmission request shall be initiated and the EUT shall remain in the "Non-valid" state.
- d) Case where the CC is being lost by the EUT and a call is initiated within the T1 period:
 - d1) the EUT shall be switched on and the STE shall transmit the CC;
 - d2) the STE shall stop transmitting the CC;
 - d3) within the period T1 from d2), a transmission request shall be initiated from the EUT;
 - d4) the EUT may transmit but within the T1 period the EUT shall enter the "Non-valid" state.

6.11.6 Network Control commands-Test method

The tests shall be performed in the following sequence:

- Transmission Enable command;
- Transmission Disable command received in the "Transmission-enabled" state;
- Transmission Disable command received in the "Initial phase" state.
- a) Transmission Enable command:
 - a1) the EUT shall be switched-on and the STE shall transmit the CC;
 - a2) the EUT shall enter the "Initial phase" state;
 - a3) a transmission request shall be initiated from the EUT, the EUT shall remain in the "Initial phase" state;
 - a4) the STE shall transmit a transmit enable command to the EUT;
 - a5) a transmission request shall be initiated from the EUT;
 - a6) the EUT shall enter the "Transmission-enabled" state and shall transmit.
- b) Transmission Disable command received in the "Transmission-enabled" state:
 - b1) continue from a6);
 - b2) the STE shall transmit a disable command to the EUT;
 - b3) the EUT shall enter the "Transmission-disabled" state within 1 second;
 - b4) a transmission request shall be initiated from the EUT;
 - b5) the EUT shall remain in the "Transmission-disabled" state;
 - b6) the STE shall transmit an enable command;
 - b7) the EUT shall enter either the "Transmission-enabled" state or the "Initial phase" state;
 - b8) if the EUT is in the "Transmission-enabled" state then the test continues with b11);
 - b9) the STE shall transmit a TxE command;

- b10) the EUT shall enter the "Transmission-enabled" state;
- b11) if a transmission request is not active any more then a new transmission request shall be initiated;
- b12) the EUT shall transmit;
- b13) the EUT transmission shall be terminated.
- c) Transmission disable command received in the "Initial phase" state:
 - c1) the EUT shall be switched-on and the STE shall transmit the CC;
 - c2) the EUT shall enter the "Initial phase" state;
 - c3) the STE shall transmit a Transmission Disable command to the EUT;
 - c4) the EUT shall enter the "Transmission-disabled" state within 1 second;
 - c5) a transmission request shall be initiated from the EUT;
 - c6) the EUT shall remain in the "Transmission-disabled" state;
 - c7) the STE shall transmit a Transmission Enable command;
 - c8) the EUT shall enter either the "Transmission-enabled" state or the "Initial phase" state;
 - c9) if the EUT is in the "Transmission-enabled" state then the test continues with c12);
 - c10) the STE shall transmit a TxE command;
 - c11) the EUT shall enter the "Transmission-enabled" state;
 - c12) if a transmission request is not active any more then a new transmission request shall be initiated;
 - c13) the EUT shall transmit;
 - c14) the EUT transmission shall be terminated.

6.11.7 Initial burst transmission-Test method

The applicant shall declare the initial burst duration.

The following test shall be performed in sequence:

- a) the EUT shall be switched-off and the STE shall transmit the CC;
- b) the EUT shall be switched-on;
- c) the EUT shall not transmit, except the initial bursts;
- d) it shall be verified that the specifications given in clause 4.2.8.7.2 are fulfilled.

6.11.8 Inhibition of transmission-Test method

The applicant shall declare the values for IT_{max} and IT_{trans} , as specified in clause 4.2.8.8.

The receive carrier to the EUT shall be removed:

- a) Within 0,5 seconds of such failure the EUT shall cease to transmit.
- b) It shall be observed that the EUT remains in the "Transmission-enabled" state and that transmissions have been suppressed within the limits of the "Carrier-off" radio state emission levels given in clause 4.2.1.2, table 3.
- c) The receive carrier to the EUT shall be restored within IT_{max} .
- d) It shall be observed that the EUT enters the "Carrier-on" radio state and begins transmission within IT_{trans} .

- e) The receive carrier to the EUT shall be removed.
- f) It shall be observed that after IT_{\max} the EUT enters the "Initial phase" state.

Annex A (normative): HS Requirements and conformance Test specifications Table (HS-RTT)

The HS Requirements and conformance Test specifications Table (HS-RTT) in table A.1 serves a number of purposes, as follows:

- it provides a statement of all the requirements in words and by cross reference to (a) specific clause(s) in the present document or to (a) specific clause(s) in (a) specific referenced document(s);
- it provides a statement of all the test procedures corresponding to those requirements by cross reference to (a) specific clause(s) in the present document or to (a) specific clause(s) in (a) specific referenced document(s);
- it qualifies each requirement to be either:
 - Unconditional: meaning that the requirement applies in all circumstances; or
 - Conditional: meaning that the requirement is dependant on the manufacturer having chosen to support optional functionality defined within the schedule.
- in the case of Conditional requirements, it associates the requirement with the particular optional service or functionality;
- it qualifies each test procedure to be either:
 - Essential: meaning that it is included with the Essential Radio Test Suite and therefore the requirement shall be demonstrated to be met in accordance with the referenced procedures;
 - Other: meaning that the test procedure is illustrative but other means of demonstrating compliance with the requirement are permitted.

Table A.1: HS Requirements and conformance Test specifications Table (HS-RTT)

Harmonized Standard EN 302 977						
The following requirements and test specifications are relevant to the presumption of conformity under the article 3.2 of the R&TTE Directive						
Requirement			Requirement Conditionality		Test Specification	
No	Description	Reference: Clause No	U/C	Condition	E/O	Reference: Clause No
1	Off-axis spurious radiation	4.2.1	U		E	6.2
2	On-axis emissions	4.2.2	U		E	6.3
3	Off-axis e.i.r.p. emission density within the band	4.2.3	U		E	6.4
4	Carrier suppression	4.2.4	U		E	6.5
5	Antenna pointing	4.2.5	U		E	6.6
6	Cessation of emissions of the VMES	4.2.6	U		E	6.9
7	Identification of VMES	4.2.7	U		E	6.10
8	Control and Monitoring Functions (CMFs)	4.2.8	U		E	6.11
9	Antenna mechanical stability	4.2.5	U		E	6.7
10	Antenna polarization alignment	4.2.5	U		E	6.8

Key to columns:**Requirement:**

No A unique identifier for one row of the table which may be used to identify a requirement or its test specification.

Description A textual reference to the requirement.

Clause Number Identification of clause(s) defining the requirement in the present document unless another document is referenced explicitly.

Requirement Conditionality:

U/C Indicates whether the requirement is to be *unconditionally* applicable (U) or is *conditional* upon the manufacturers claimed functionality of the equipment (C).

Condition Explains the conditions when the requirement shall or shall not be applicable for a technical requirement which is classified "conditional".

Test Specification:

E/O Indicates whether the test specification forms part of the Essential Radio Test Suite (E) or whether it is one of the Other Test Suite (O).

NOTE: All tests whether "E" or "O" are relevant to the requirements. Rows designated "E" collectively make up the Essential Radio Test Suite; those designated "O" make up the Other Test Suite; for those designated "X" there is no test specified corresponding to the requirement. The completion of all tests classified "E" as specified with satisfactory outcomes is a necessary condition for a presumption of conformity. Compliance with requirements associated with tests classified "O" or "X" is a necessary condition for presumption of conformity, although conformance with the requirement may be claimed by an equivalent test or by manufacturer's assertion supported by appropriate entries in the technical construction file.

Clause Number Identification of clause(s) defining the test specification in the present document unless another document is referenced explicitly. Where no test is specified (that is, where the previous field is "X") this field remains blank.

Annex B (informative): Mechanical stability methodology

This test based on an analytical or numerical analysis is performed in two stages.

In the first stage the loads generated by the maximum wind speed is computed on the EME, taking into account the intrinsic properties of the materials.

In the second stage the computed loads is applied to the structure.

The purpose of the analysis is twofold:

- a) To show that the torque and the fields of force applied to the EME structure under nominated conditions do not reach any of the following:
 - the point where deformation fouls the antenna pointing mechanism;
 - the yield point of any element of the structure;
 - the buckling point of any element of the structure.

NOTE: The yield point is elastic limit of the material and the buckling point is the failure point for the material.

- b) To compute equivalent static loads (force and torque) applied to the critical attachment points of the structures, e.g.:
 - for antennas without a radome:
 - reflector-mounting legs fixing point;
 - reflector-struts;
 - LNB- struts.
 - for antennas with a radome:
 - radome surface;
 - radome mounting points.

Analysis and load applications procedure:

- a) The air related parameters, namely the kinetic viscosity used to calculate drags at the rims of the structure is calculated with the standard atmospheric environmental conditions (temperature = 293 K, air pressure = $1,013 \times 10^5$ Pascal).
- b) The computations needed to derive the field of force and torque and the equivalent static stresses is carried out for each of the following variables:
 - elevation angle: maximum and minimum for antennas without a radome;
 - wind direction: in steps of 45° around the EME unit;
 - maximum relative wind speed: 100 km/h;
 - gust wind speed: 130 km/h for 3 seconds.

Verification of the simulated results is carried out to ensure that the yield point limits were not exceeded for any self-contained element.

The calculated equivalent static loads is applied at any identified critical fixing point of the assembly, whilst the loads are applied the above deck unit is observed and any distortion noted.

The test report should contain the following information:

- the computation method used;
- the description of the test equipment;
- the description of the tests performed;
- the results of the safety margin test;
- any signs of distortion observed;
- the results of the measurements of the deviation of the antenna or radome position;
- the component deviation with respect to each other.

Annex C (informative): Typical Scan and Acceleration Rates

Table C.1 indicates the typical antenna scan and acceleration rates required to maintain performance under the environmental profile of clause 4.1.1 in compliance with the technical specifications given in the remainder of clause 4.

Table C.1: Typical Scan and Acceleration Rates

		Class A	Class B
Scan rate	Azimuth	24 °/s	400 °/s
	Elevation	12 °/s	400 °/s
	Polarization	12 °/s	400 °/s
Acceleration	Azimuth	50 °/s ²	500 °/s ²
	Elevation	50 °/s ²	500 °/s ²
	Polarization	40 °/s ²	400 °/s ²

Annex D (informative): The EN title in the official languages

The enlargement of the European Union (EU) resulted in a requirement from the EU for a larger number of languages for the translation of the titles of Harmonized Standards and mandated ENs that are to be listed in the Official Journal to support the implementation of this legislation.

For this reason the title translation concerning the present document can be consulted via the [e-approval](#) application.

Annex E (informative): Bibliography

- Council Directive 73/23/EEC of 19 February 1973 on the harmonization of the laws of Member States relating to Electrical Equipment designed for use within certain voltage limits (LV Directive).
- Council Directive 89/336/EEC of 3 May 1989 on the approximation of the laws of the Member States relating to electromagnetic compatibility (EMC Directive).
- Directive 2004/40/EC of the European Parliament and of the Council of 29 April 2004 on the minimum health and safety requirements regarding the exposure of workers to the risks arising from physical agents (electromagnetic fields) (18th individual Directive within the meaning of Article 16(1) of Directive 89/391/EEC).
- ETSI ETR 169 (1995): "Satellite Earth Stations and Systems (SES); Common Technical Regulations (CTRs) in the satellite earth station equipment field".
- CENELEC BS EN 60068: "Environmental testing. Test methods for vibration and shock".
- CENELEC EN 55022: "Limits and methods of measurement of radio disturbance characteristics of information technology equipment".
- SAE J1211: "Recommended Environmental Practices for Electronic Equipment Design, Recommended Practice".
- CEPT/ERC/Recommendation 74-01 (2005): "Unwanted emissions in the spurious domain".

History

Document history			
V1.1.0	September 2008	Public Enquiry	PE 20090115: 2008-09-17 to 2009-01-15
V1.1.1	October 2009	Vote	V 20091202: 2009-10-03 to 2009-12-02