

Draft **ETSI EN 302 663** V1.2.0 (2012-11)



**Intelligent Transport Systems (ITS);
Access layer specification for
Intelligent Transport Systems operating
in the 5 GHz frequency band**

Reference

REN/ITS-0040028

Keywords

ITS, layer 1, layer 2, MAC, profile, radio

ETSI

650 Route des Lucioles
F-06921 Sophia Antipolis Cedex - FRANCE

Tel.: +33 4 92 94 42 00 Fax: +33 4 93 65 47 16

Siret N° 348 623 562 00017 - NAF 742 C
Association à but non lucratif enregistrée à la
Sous-Préfecture de Grasse (06) N° 7803/88

Important notice

Individual copies of the present document can be downloaded from:

<http://www.etsi.org>

The present document may be made available in more than one electronic version or in print. In any case of existing or perceived difference in contents between such versions, the reference version is the Portable Document Format (PDF). In case of dispute, the reference shall be the printing on ETSI printers of the PDF version kept on a specific network drive within ETSI Secretariat.

Users of the present document should be aware that the document may be subject to revision or change of status. Information on the current status of this and other ETSI documents is available at

<http://portal.etsi.org/tb/status/status.asp>

If you find errors in the present document, please send your comment to one of the following services:

http://portal.etsi.org/chaicor/ETSI_support.asp

Copyright Notification

No part may be reproduced except as authorized by written permission.
The copyright and the foregoing restriction extend to reproduction in all media.

© European Telecommunications Standards Institute 2012.
All rights reserved.

DECT™, **PLUGTESTS™**, **UMTS™** and the ETSI logo are Trade Marks of ETSI registered for the benefit of its Members.
3GPP™ and **LTE™** are Trade Marks of ETSI registered for the benefit of its Members and of the 3GPP Organizational Partners.
GSM® and the GSM logo are Trade Marks registered and owned by the GSM Association.

Contents

Intellectual Property Rights	4
Foreword.....	4
Introduction	4
1 Scope	5
2 References	5
2.1 Normative references	5
2.2 Informative references.....	6
3 Definitions, symbols and abbreviations	7
3.1 Definitions	7
3.2 Symbols.....	7
3.3 Abbreviations	7
4 General requirements	8
4.1 Architecture.....	8
4.2 Frequency allocation	10
4.2.1 Introduction.....	10
4.2.2 ITS-G5A frequency band.....	10
4.2.3 ITS-G5B frequency band.....	10
4.2.4 ITS-G5C frequency band.....	11
4.2.5 ITS-G5D frequency band.....	11
4.3 Channel allocation.....	11
4.4 Transmit requirements.....	12
4.5 Receive requirements	12
4.6 Quality of service	12
5 ITS-G5 Access layer	12
5.1 Decentralized Congestion Control	12
5.2 Coexistence between CEN DSRC and ITS-G5.....	12
6 Conformance and test methods	13
Annex A (normative): MIB parameter	14
Annex B (informative): Introduction to IEEE 802.11-2012.....	15
B.1 Introduction	15
B.2 Network topology.....	16
B.3 Physical layer	16
B.4 Medium access control.....	17
B.4.1 Introduction	17
B.4.2 Backoff procedure	18
B.4.3 Medium access control.....	18
B.4.4 EDCA parameters, AC and UP	19
B.5 Implications of the dot11OCBAActivated set to true	21
Annex C (informative): ITS-G5C frequency band.....	22
Annex D (informative): Bibliography.....	23
History	24

Intellectual Property Rights

IPRs essential or potentially essential to the present document may have been declared to ETSI. The information pertaining to these essential IPRs, if any, is publicly available for **ETSI members and non-members**, and can be found in ETSI SR 000 314: "*Intellectual Property Rights (IPRs); Essential, or potentially Essential, IPRs notified to ETSI in respect of ETSI standards*", which is available from the ETSI Secretariat. Latest updates are available on the ETSI Web server (<http://ipr.etsi.org>).

Pursuant to the ETSI IPR Policy, no investigation, including IPR searches, has been carried out by ETSI. No guarantee can be given as to the existence of other IPRs not referenced in ETSI SR 000 314 (or the updates on the ETSI Web server) which are, or may be, or may become, essential to the present document.

Foreword

This draft European Standard (EN) has been produced by ETSI Technical Committee Intelligent Transport System (ITS), and is now submitted for the combined Public Enquiry and Vote phase of the ETSI standards EN Approval Procedure.

Proposed national transposition dates	
Date of latest announcement of this EN (doa):	3 months after ETSI publication
Date of latest publication of new National Standard or endorsement of this EN (dop/e):	6 months after doa
Date of withdrawal of any conflicting National Standard (dow):	6 months after doa

Introduction

The present document is outlining the two lowest layers - physical layer and data link layer - in the protocol stack for supporting vehicle-to-vehicle communications in an *ad hoc* network to be used at the 5,9 GHz frequency band allocated in Europe. The two lowest layers are termed access layer in the present document and the technology specified for the access layer is collectively called ITS-G5. The ITS-G5 standard is using already existing standards for communications. The data link layer is divided into two sublayers; medium access control and logical link control. The physical layer and the medium access control layer are covered in IEEE 802.11 [3]. The logical link control is based on the ANSI/IEEE Std 802.2 [5]. The ITS-G5 standard also adds features for decentralized congestion control (DCC) methods [8] to control the network load and avoid unstable behaviour.

By setting the management information base (MIB) parameter `dot11OCBActivated` to true in IEEE 802.11 [3] a new capability is introduced namely the possibility to communicate outside the context of a basic service set (BSS), which is the smallest building block of a 802.11 network. Communication outside the BSS implies that neither authentication/association procedures nor security mechanisms are supported. Further, no access point functionality is present. The disable of these features also affects other built-in features of IEEE 802.11 [3]. The requirement that nodes should share a common clock is no longer valid while `dot11OCBActivated` is true. Further, scanning of available frequency channels for joining a BSS is also disabled implying that communication outside the context of the BSS requires that a node is configured for a predetermined frequency channel where more information about other available frequency channels can be obtained.

NOTE: IEEE has compiled a new version of the 802.11 standard where all approved amendments produced between 2007 and 2011 have been enrolled in the base standard including 802.11p. This new version called IEEE 802.11-2012 [3] was approved in March 2012. Due to this new version of 802.11 the 802.11p amendment is classified as superseded.

1 Scope

The scope of the present document is to define the two lowest layers, physical layer and the data link layer, grouped into the access layer of the ITS station reference architecture [i.8]. The access layer technology that is specified in the present document is collectively called ITS-G5. It is part of the communication stack supporting data exchange between mobile stations without prior network set-up, i.e. *ad hoc* mode, for the following frequency bands in Europe:

- ITS-G5A: Operation of ITS-G5 in European ITS frequency bands dedicated to ITS for safety related applications in the frequency range 5,875 GHz to 5,905 GHz.
- ITS-G5B: Operation in European ITS frequency bands dedicated to ITS non-safety applications in the frequency range 5,855 GHz to 5,875 GHz.
- ITS-G5D: Operation of ITS applications in the frequency range 5,905 GHz to 5,925 GHz.

The ITS-G5 technology is based on IEEE 802.11-2012 [3] and ANSI/IEEE Std 802.2 [5]. By setting the MIB variable `dot11OCBActivated` to true in IEEE 802.11-2012 communication outside the context of a BSS is possible. This type of communication allows for immediate exchange of data frames, avoiding the management overhead used with the establishment of a network. All requirements in IEEE 802.11-2012 [3] associated with communication "outside the context of a BSS" are also requirements in the present document. All optional functionality in IEEE 802.11-2012 [3] associated with communication "outside the context of a BSS" is also optional in the present document.

2 References

References are either specific (identified by date of publication and/or edition number or version number) or non-specific. For specific references, only the cited version applies. For non-specific references, the latest version of the reference document (including any amendments) applies.

Referenced documents which are not found to be publicly available in the expected location might be found at <http://docbox.etsi.org/Reference>.

NOTE: While any hyperlinks included in this clause were valid at the time of publication, ETSI cannot guarantee their long term validity.

2.1 Normative references

The following referenced documents are necessary for the application of the present document.

- [1] ETSI EN 302 571 (V1.1.1): "Intelligent Transport Systems (ITS); Radiocommunications equipment operating in the 5 855 MHz to 5 925 MHz frequency band; Harmonized EN covering the essential requirements of article 3.2 of the R&TTE Directive".
- [2] ETSI TS 102 792 (V1.1.1): "Intelligent Transport Systems (ITS); Mitigation techniques to avoid interference between European CEN Dedicated Short Range Communication (CEN DSRC) equipment and Intelligent Transport Systems (ITS) operating in the 5 GHz frequency range".
- [3] IEEE 802.11-2012: "IEEE Standard for Information technology - Telecommunications and information exchange between systems - Local and metropolitan area networks-Specific requirements - Part 11: Wireless LAN Medium Access Control (MAC) and Physical Layer (PHY) Specifications".
- [4] IEEE 802-2001: "IEEE Standard for Local and Metropolitan Area Networks: Overview and Architecture".
- [5] ANSI/IEEE Std 802.2 (1998): "IEEE Standard for Information technology - Telecommunications and information exchange between systems - Local and metropolitan area networks - Specific requirements - Part 2: Logical Link Control".
- [6] ISO/IEC 7498-1:1994: "Information technology - Open Systems Interconnection - Basic Reference Model: The Basic Model".

- [7] ITU-T Recommendation X.691 (2008): "Information technology - ASN.1 encoding rules: Specification of Packed Encoding Rules (PER)".
- [8] ETSI TS 102 687 (V1.1.1): "Intelligent Transport Systems (ITS); Decentralized Congestion Control Mechanisms for Intelligent Transport Systems operating in the 5 GHz range; Access layer part".

2.2 Informative references

The following referenced documents are not necessary for the application of the present document but they assist the user with regard to a particular subject area.

- [i.1] ETSI EN 300 674 (all parts): "Electromagnetic compatibility and Radio spectrum Matters (ERM); Road Transport and Traffic Telematics (RTTT); Dedicated Short Range Communication (DSRC) transmission equipment (500 kbit/s / 250 kbit/s) operating in the 5,8 GHz Industrial, Scientific and Medical (ISM) band".
- [i.2] ECC/REC/(08)01: "ECC Recommendation (08)01 on the use of the band 5855-5875 MHz for Intelligent Transport Systems (ITS)".
- [i.3] ERC/DEC(99)23: "ERC Decision of 29 November 1999 on the harmonised frequency bands to be designated for the introduction of High Performance Radio Local Area Networks (HIPERLANs)".
- [i.4] ECC/DEC(02)01: "ECC Decision of 15 March 2002 on the frequency bands to be designated for the co-ordinated introduction of Road Transport and Traffic Telematic Systems".
- [i.5] Commission Decision 2005/513/EC of 11 July 2005 on the harmonised use of radio spectrum in the 5 GHz frequency band for the implementation of wireless access systems including radio local area networks (WAS/RLANs).
- [i.6] Commission Decision 2007/90/EC of 12 February 2007 amending Decision 2005/513/EC on the harmonised use of radio spectrum in the 5 GHz frequency band for the implementation of Wireless Access Systems including Radio Local Area Networks (WAS/RLANs).
- [i.7] Commission Decision 2008/671/EC of 5 August 2008 on the harmonised use of radio spectrum in the 5 875-5 905 MHz frequency band for safety-related applications of Intelligent Transport Systems (ITS).
- [i.8] ETSI EN 302 665 (V1.1.1): "Intelligent Transport Systems (ITS); Communications Architecture".
- [i.9] ETSI TS 102 724 (V0.0.11): "Intelligent Transport Systems (ITS); Harmonized Channel Specifications for Intelligent Transport Systems operating in the 5 GHz frequency band".
- [i.10] ANSI/IEEE Std 802.1D 1998: "IEEE Standard for Information technology - Telecommunications and information exchange between systems - Local and metropolitan area networks - Common specifications- Part 3: Media Access Control (MAC) Bridges".
- [i.11] IEEE 802.11p-2010: "IEEE Standard for Information technology-- Local and metropolitan area networks-- Specific requirements-- Part 11: Wireless LAN Medium Access Control (MAC) and Physical Layer (PHY) Specifications Amendment 6: Wireless Access in Vehicular Environments".
- [i.12] IEEE 802.11a-1999: "IEEE Standard for Telecommunications and Information Exchange Between Systems - LAN/MAN Specific Requirements - Part 11: Wireless Medium Access Control (MAC) and physical layer (PHY) specifications: High Speed Physical Layer in the 5 GHz band".
- [i.13] IEEE 802.11e-2005: "IEEE Standard for Information technology-- Local and metropolitan area networks-- Specific requirements-- Part 11: Wireless LAN Medium Access Control (MAC) and Physical Layer (PHY) Specifications - Amendment: Medium Access Method (MAC) Quality of Service Enhancements".
- [i.14] ETSI EN 301 893 (V1.5.1): "Broadband Radio Access Networks (BRAN); 5 GHz high performance RLAN; Harmonized EN covering the essential requirements of article 3.2 of the R&TTE Directive".

- [i.15] ETSI EN 302 502 (V1.2.1): "Broadband Radio Access Networks (BRAN); 5,8 GHz fixed broadband data transmitting systems; Harmonized EN covering the essential requirements of article 3.2 of the R&TTE Directive".

3 Definitions, symbols and abbreviations

3.1 Definitions

For the purposes of the present document, the terms and definitions given in [1], [2], [3], [4], [5], [6], [7] and the following apply:

Ethertype: identifier to the network protocol above the data link layer

ITS-G5: access technology to be used in frequency bands dedicated for European intelligent transport System (ITS)

ITS-G5 Control Channel: a physical channel for ITS-G5

ITS-G5 Service Channel: a physical channel for ITS-G5

ITS-G5 Station: ITS station that operates using ITS-G5 channels

3.2 Symbols

For the purposes of the present document, the following symbols apply:

aCW_{max}	Maximum value of Contention Window
aCW_{min}	Minimum value of Contention Window
<i>AIFS</i>	Arbitration InterFrame Space
<i>AIFSN</i>	Arbitration InterFrame Space Number
<i>aSIFSTime</i>	Short InterFrame Space defined by the physical layer
<i>aSlotTime</i>	A slot time defined by the physical layer
<i>CW</i>	Contention Window
CW_{max}	Maximum value of Contention Window
CW_{min}	Minimum value of Contention Window

3.3 Abbreviations

For the purposes of the present document, the following abbreviations apply:

AC	Access Category
AC_BE	Access Category Best Effort
AC_BK	Access Category Background
AC_VI	Access Category Video
AC_VO	Access Category Voice
ACK	Acknowledgment
AIFS	Arbitration InterFrame Space
AIFSN	Arbitration InterFrame Space Number
AP	Access Point
BE	Best Effort
BK	Background
BPSK	Binary Phase Shift Keying
BRAN	Broadband Radio Access Network
BSS	Basic Service Set
BSSID	Basic Service Set Identification
CCH	Control Channel
CEN	European Committee for Standardisation
CSMA/CA	Carrier Sense Multiple Access with Collision Avoidance
CW	Contention Window

DCC	Decentralized Congestion Control
DCF	Distributed Coordination Function
DFS	Dynamic Frequency Selection
DIFS	Distributed InterFrame Space
DSRC	Dedicated Short-Range Communication
ECC	Electronic Communication Committee
EDCA	Enhanced Distribution Coordination Access
EE	Excellent Effort
EIRP	Effective Isotropic Radiated Power
EN	European Norm
ETC	Electronic Toll Collection
G5-CCH	ITS-G5 Control Channel
G5-SCH	ITS-G5 Service Channel
GPS	Global Positioning System
IBSS	Independent Basic Service Set
IEEE	Institute of Electrical and Electronics Engineers
ITS	Intelligent Transport System
ITS-G5A	Frequency band ranging from 5 875 MHz to 5 905 MHz
ITS-G5B	Frequency band ranging from 5 855 MHz to 5 875 MHz
ITS-G5C	Frequency band ranging from 5 470 MHz to 5 725 MHz
ITS-G5D	Frequency band ranging from 5 905 MHz to 5 925 MHz
LLC	Logical Link Control
MAC	Medium Access Control
MIB	Management Information Base
MPDU	MAC Protocol Data Unit
NC	Network Control
OFDM	Orthogonal Frequency Division Multiplexing
OSI	Open Systems Interconnect
PHY	Physical layer
PLCP	Physical Layer Convergence Protocol
PPDU	PLCP Protocol Data Unit
PSDU	PLCP Service Data Unit
QAM	Quadrature Amplitude Modulation
QoS	Quality of Service
QPSK	Quadrature Phase Shift Keying
RLAN	Radio Local Area Network
SNAP	SubNetwork Access Protocol
TPC	Transmit Power Control
TR	Technical Report
TS	Technical Specification
TX	Transmitter
UP	User Priority
VI	Video
VO	Voice
WLAN	Wireless Local Area Network

4 General requirements

4.1 Architecture

Figure 1 shows the ITS station reference architecture [i.8]. The present document specifies one access technology for cooperative ITS namely ITS-G5 based on IEEE 802.11 [3]. The access layer of the ITS station reference architecture includes both the physical layer and the data link layer of the OSI model.

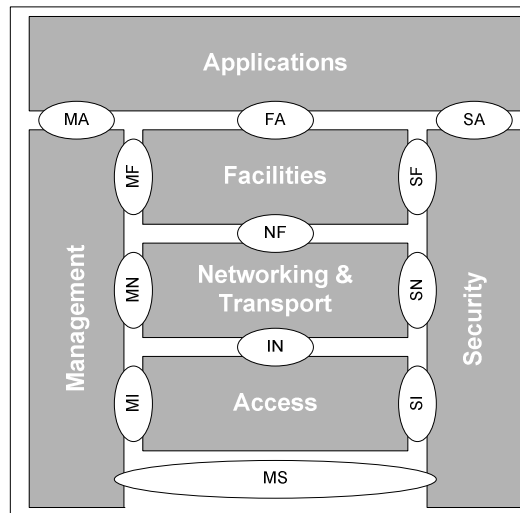

Figure 1: ITS station reference architecture

In Figure 2 the ITS-G5 access layer architecture is outlined. The security entity shown in Figure 1 is included as a part of the management entity [i.8].

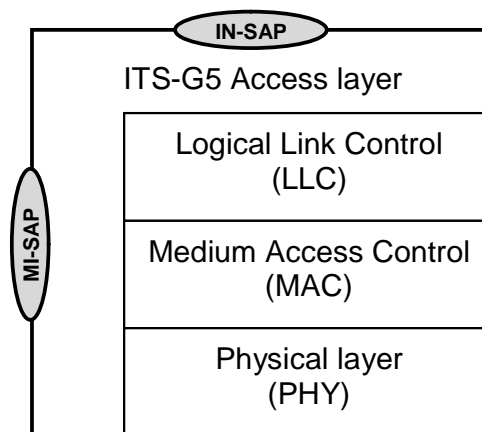

Figure 2: ITS-G5 access layer architecture

An ITS-G5 station shall be compliant with the following IEEE standards:

- 1) The physical (PHY) layer orthogonal frequency division multiplexing (OFDM) as defined in clause 18 of IEEE 802.11-2012 [3].
- 2) The medium access control (MAC) layer functionality as defined in IEEE 802.11-2012 [3] by setting the MIB parameter `dot11OCBActivated` to true enabling communication outside the context of a basic service set (BSS).
- 3) The logical link control (LLC) as defined in ANSI/IEEE Std. 802.2 [5] and the mode of operation is set to Type 1 - unacknowledged connectionless mode.
- 4) The subnetwork access protocol (SNAP) as defined in IEEE 802-2001 [4].

An ITS-G5 station shall comply to the functionality defined in clause 5 ITS-G5 Access layer.

The SNAP provides the possibility to distinguish between different network protocols through EtherTypes.

In annex B an informative introduction to IEEE 802.11-2012 [3], where the MIB parameter `dot11OCBActivated` is set to true, is given to facilitate the reading of the present document.

4.2 Frequency allocation

4.2.1 Introduction

Table 1 shows the frequency ranges, related regulatory requirements, intended usage and harmonized standards to be used for cooperative ITS within the European Union.

Table 1: Frequency allocation in the European Union

	Frequency range [MHz]	Usage	Regulation	Harmonized standard
ITS-G5D	5 905 to 5 925	Future ITS applications	ECC Decision [i.4]	EN 302 571 [1]
ITS-G5A	5 875 to 5 905	ITS road safety related applications	Commission Decision [i.7]	EN 302 571 [1]
ITS-G5B	5 855 to 5 875	ITS non-safety applications	ECC Recommendation [i.2]	EN 302 571 [1]
ITS-G5C	5 470 to 5 725	RLAN (BRAN, WLAN)	ERC Decision [i.3] Commission Decisions [i.5] and [i.6]	EN 301 893 [i.14]

NOTE: The Commission Decision [i.7] is in line with the ECC Decision [i.4].

Figure 3 illustrates the channel allocation in the 5 GHz range for the frequency bands listed in Table 1. It also shows the European bands for Dedicated Short Range Communication (DSRC), which in Europe refers to the EN 300 674 standard [i.1] used for electronic toll collection (so called CEN DSRC), for instance. DSRC is regulated by the ECC Decision [i.4].

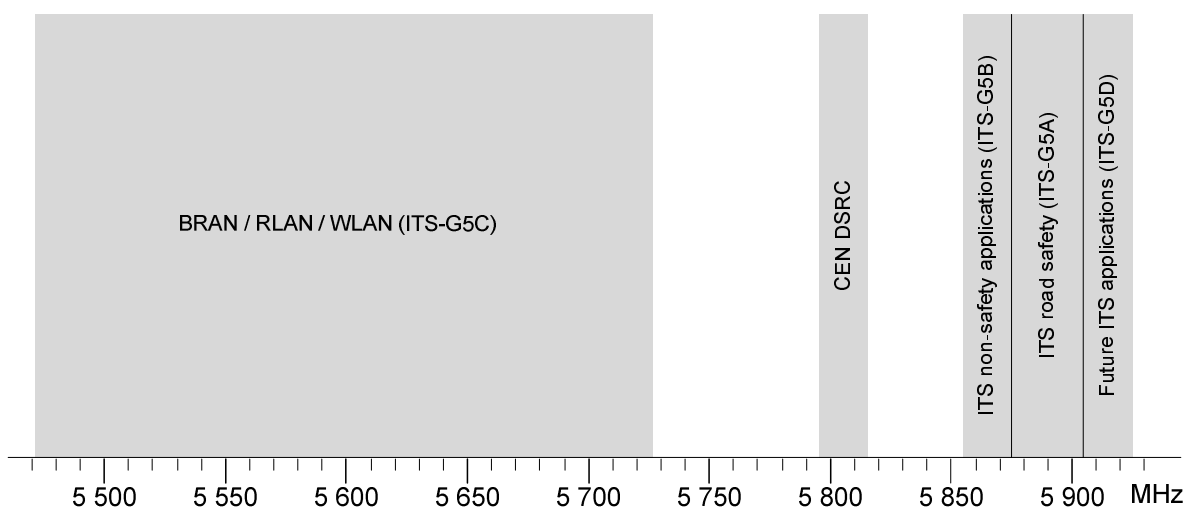

Figure 3: Channel allocation for the 5 GHz frequency range

4.2.2 ITS-G5A frequency band

The ITS-G5A frequency band is set aside for ITS road traffic safety applications and it is only allowed to be used by ITS-G5 compliant stations as specified in the present document.

4.2.3 ITS-G5B frequency band

The ITS-G5B frequency band is set aside for ITS non-safety road traffic applications and it is only allowed to be used by ITS-G5 compliant stations as specified in the present document.

4.2.4 ITS-G5C frequency band

The conditions for using the ITS-G5C band is given in the Commission Decisions [i.5] and [i.6]. The technical requirements for this band are detailed in [i.14].

NOTE: The ITS-G5C band is also referred to broadband radio access networks (BRAN), radio local area network (RLAN) and wireless local area network (WLAN).

Operation in the RLAN band requires transmit power control (TPC), a procedure for dynamic frequency selection (DFS) and uniform spreading, in order to detect signals from radar systems and to avoid co-channel interference. This functionality is not supported when setting the MIB parameter `dot11OCBActivated` to true. Therefore, it is not possible to use the ITS-G5 stations for communication in the ITS-G5C band outside the context of a basic service set, the rationale behind this is detailed in the informative annex C.

4.2.5 ITS-G5D frequency band

This frequency band is set aside for future usage of ITS road traffic applications and it is allowed to be used by ITS-G5 compliant stations as specified in the present document.

4.3 Channel allocation

Channel allocation shall be as specified in Table 1. One physical channel is allocated to be the control channel (CCH), termed G5-CCH. Seven fixed service channels and one variable physical service channel are identified as G5-SCHs.

Table 2: European channel allocation

Channel type	Centre frequency	IEEE 802.11 [3] channel number	Channel spacing	Default data rate	TX power limit	TX power density limit
G5-CCH	5 900 MHz	180	10 MHz	6 Mbit/s	33 dBm EIRP	23 dBm/MHz
G5-SCH2	5 890 MHz	178	10 MHz	12 Mbit/s	23 dBm EIRP	13 dBm/MHz
G5-SCH1	5 880 MHz	176	10 MHz	6 Mbit/s	33 dBm EIRP	23 dBm/MHz
G5-SCH3	5 870 MHz	174	10 MHz	6 Mbit/s	23 dBm EIRP	13 dBm/MHz
G5-SCH4	5 860 MHz	172	10 MHz	6 Mbit/s	0 dBm EIRP	-10 dBm/MHz
G5-SCH5	5 850 MHz	182	10 MHz	6 Mbit/s	0 dBm EIRP	-10 dBm/MHz
G5-SCH6	5 910 MHz	184	10 MHz	6 Mbit/s	0 dBm EIRP	-10 dBm/MHz
G5-SCH7	As described in [i.14] for the band 5 470 MHz to 5 725 MHz	94 to 145	several	dependent on channel spacing	30 dBm EIRP (DFS master) 23 dBm EIRP (DFS slave)	17 dBm/MHz 10 dBm/MHz

NOTE: With respect to emission limits (power limit/power density limit), the more stringent requirement applies.

The usage of G5-CCH and G5-SCH1 to G5-SCH2 are dedicated basically for ITS road safety. G5-SCH3 to G5-SCH5 are essentially dedicated for ITS road traffic efficiency. A more detailed description of usage is defined in [i.9]. In Table 3 the different physical channels are mapped to the frequency ranges found in Table 1 for clarification.

Table 3: European channel allocation

	Channel type	Frequency range [MHz]	IEEE channel number
ITS-G5A	G5-CCH	5 895 to 5 905	180
	G5-SCH2	5 885 to 5 895	178
	G5-SCH1	5 875 to 5 885	176
ITS-G5B	G5-SCH3	5 865 to 5 875	174
	G5-SCH4	5 855 to 5 865	172
ITS-G5C	G5-SCH7	5 470 to 5 725	94 to 145
ITS-G5D	G5-SCH5	5 905 to 5 915	182
ITS-G5D	G5-SCH6	5 915 to 5 925	184

In Figure 4 the channel types with the maximum power density limit for each channel according to Table 2 is depicted for ITS-G5A, ITS-G5B, and ITS-G5D.

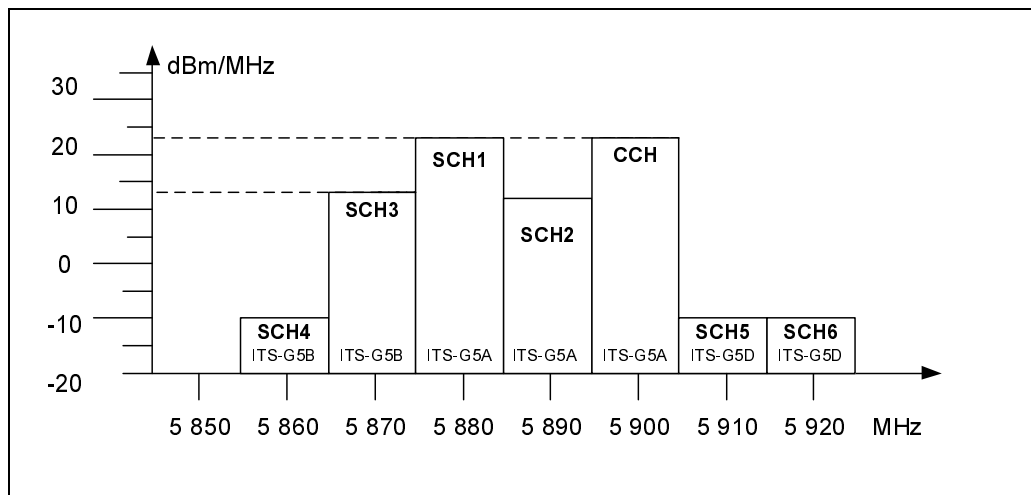

Figure 4: Maximum limit of mean spectral power density for each channel type in ITS-G5A, ITS-G5B, and ITS-G5D

4.4 Transmit requirements

Transmit power of an ITS-G5 station operating in the ITS-G5A, ITS-G5B or ITS-G5D frequency bands shall be controlled by mechanism based on the DCC as defined in [8] and clause 5.

4.5 Receive requirements

The receiver requirements for ITS-G5 are defined by regulation in [1].

4.6 Quality of service

An ITS-G5 station shall transmit data using EDCA as defined in clause 9.19.2 of IEEE 802.11-2012 [3]. The EDCA default values are static for all ITS-G5 stations and not negotiated before transmission. The default values are found in Table 8-106 in [3], also found in Table B.6. The usage of the queues as defined in Table B.6 is described in TS 102 687 [8].

5 ITS-G5 Access layer

5.1 Decentralized Congestion Control

ITS applications, in particular safety-related applications, have high requirements on the reliability and the latency of the data transmission. Due to the MAC protocol of IEEE 802.11-2012 [3], and the limited bandwidth of ITS-G5, the data load on the wireless channels can exceed the available capacity in some situations. Therefore, decentralized congestion control (DCC) methods as specified in TS 102 687 [8] are required in ITS-G5 stations in order to control the channel load and avoid unstable behaviour of the system.

5.2 Coexistence between CEN DSRC and ITS-G5

ITS-G5 stations shall avoid to interfere with CEN DSRC, see Figure 3. Therefore, mitigation techniques are required for ITS-G5 stations. They are specified in TS 102 792 [2].

6 Conformance and test methods

Declaration of conformity of the ITS-G5 physical layer with European Harmonized Standards shall be done according to [1].

Conformance and test methods for the ITS-G5 communication protocols are not specified in the present document.

Annex A (normative): MIB parameter

Table A.1 defines the relevant value of the MIB parameter specified in [3] that shall be set by ITS-G5 stations using ITS-G5A, ITS-G5B, and ITS-G5D bands.

Table A.1: MIB parameter

Name	Initial value	Value may be changed	Remark
dot11OCBActivated	True	No	Specified in [3]. When True, operation outside the context of a BSS applies.

Annex B (informative): Introduction to IEEE 802.11-2012

B.1 Introduction

The aim with the present informative annex is to introduce the reader of the present document to the IEEE 802.11-2012 standard [3] when used in the vehicular environment.

NOTE 1: The annex is a brief introduction and the reader is referred to IEEE 802.11-2012 [3] for further details.

In March 2012, the amendment IEEE 802.11p-2010 [i.11] was classified as superseded and enrolled into the new version of IEEE 802.11-2012 [3]. IEEE 802.11p-2010 [i.11] was developed to support new emerging applications utilizing wireless communication between vehicles in an effort to decrease road traffic accidents and improve road traffic efficiency. IEEE 802.11p-2010 [i.11] added a new management information base (MIB) variable called `dot11OCBActivated` and by setting this to true a new capability in the IEEE 802.11 [3] is introduced namely the possibility to communicate outside the context of a basic service set (BSS), which is the smallest building block of an 802.11 network. The side effect of this are that the BSS authentication and association procedures are removed because this is a time consuming process and in a vehicular environment where nodes are highly mobile and transactions may not be completed until the nodes are out of each other's radio ranges. The communication outside of a BSS can be thought of as *ad hoc* communications and should not be confused with the independent BSS network topology supported in IEEE 802.11-2012 [3]. To distinguish between communication within a BSS and outside of a BSS the network identification (basic service set id, BSSID) is set to a wildcard in every frame transmitted in an 802.11p communications. The removal of authentication and association procedures implies further changes to IEEE 802.11-2012 standard [3], which will be outlined in the following clauses.

NOTE 2: An amendment is an improvement to an already existing work implying that IEEE 802.11p-2010 [i.11] was not standalone and knowledge about the core IEEE Std 802.11 was necessary to understand the functionality of IEEE Std 802.11p.

NOTE 3: All primitives ending with "Enabled" in the former published version of IEEE Std 802.11 have changed name to "Activated" in the new version [3].

NOTE 4: To facilitate the reading of the current annex the name 802.11p will be used throughout the text referring when the `dot11OCBActivated` is set to true enabling communication outside the context of a BSS in IEEE 802.11-2012. The references to specific clauses will be made to IEEE 802.11-2012 [3] and not the superseded IEEE Std 802.11p-2010 document [i.11].

IEEE Std 802.11 offers several physical (PHY) layers and one common medium access control (MAC) sublayer with Quality of Service (QoS) support. IEEE Std 802.11p [i.11] is using the orthogonal frequency division multiplexing (OFDM) PHY detailed in clause 18 of [3] (a.k.a. IEEE 802.11a-1999 [i.12]), with minor additions, and it has support for QoS through the former amendment called IEEE 802.11e-2005 [i.13] (approved in 2004 and enrolled in [3]).

B.2 Network topology

The IEEE 802.11-2012 standard contains two basic network topologies [3]: the infrastructure BSS and the independent BSS (IBSS). The former contains an access point (AP) and data traffic usually takes a detour through the AP even though two nodes are closely co-located. The IBSS is a set of nodes communicating directly with each other and this is also called *ad hoc* or peer-to-peer network. Both these topologies are aimed for nomadic devices and synchronization is required between nodes performed via beacons. Further, they are identified with a unique BSSID. Association and authentication are required in infrastructure BSS whereas in IBSS association is not used and communication can take place in an unauthenticated mode. With the introduction of 802.11p a new capability of the 802.11 is introduced, namely communication outside the context of a BSS, see clause 4.3.11 of 802.11 [3]. The communication outside of a BSS is enabled by setting the MIB variable `dot11OCBActivated` to true. In this mode authentication, association and security between nodes are disabled at the MAC sublayer. This implies that active and passive scanning of BSS and IBSS are disabled. The scanning on frequency channels for the node in order to join an existing network is no longer enabled. Therefore, the implementation of 802.11p in the vehicular environment requires predetermined frequency channels such as the G5-CCH to be set in the management.

B.3 Physical layer

The PHY in 802.11p is OFDM detailed in clause 18 of 802.11. The basic idea is to divide the available frequency spectrum into narrower subchannels (subcarriers). The high-rate data stream is split into a number of lower-rate data streams transmitted simultaneously over a number of subcarriers, where each subcarrier is narrow banded. There are 52 subcarriers, where 48 are used for data and 4 are pilot carriers. The OFDM PHY layer has support for eight different transfer rates, which are achieved by using different modulation schemes and coding rates. In Table B.1 the different transfer rates together with the coding schemes used in 802.11p are tabulated for 10 MHz frequency channels. Support of three transfer rates are mandatory; 3 Mbit/s, 6 Mbit/s, and 12 Mbit/s.

NOTE: The OFDM PHY supports 3 different frequency channel bandwidths, i.e. 5 MHz, 10 MHz and 20 MHz, where the latter is commonly used for WLAN at 5 GHz and 10 MHz is used for the vehicular environment at 5,9 GHz.

Table B.1: Transfer rates, modulation schemes and coding rates in 802.11p

Transfer rate [Mbit/s]	Modulation scheme	Coding rate	Data bits per OFDM symbol	Coded bits per OFDM symbol
3	BPSK	1/2	24	48
4,5	BPSK	3/4	36	48
6	QPSK	1/2	48	96
9	QPSK	3/4	72	96
12	16-QAM	1/2	96	192
18	16-QAM	3/4	144	192
24	64-QAM	2/3	192	288
27	64-QAM	3/4	216	288

In Figure B.1 the resulting PHY packet is depicted, i.e. the physical layer convergence procedure (PLCP) protocol data unit (PPDU). The PLCP service data unit (PSDU) contains the data from the MAC layer including MAC header and trailer (collectively named MAC protocol data unit, MPDU). The preamble is used for synchronizing the receiver and the signal field contains information about the packet length and at what data rate the data field is transmitted with. The signal field is always transmitted using BPSK with a coding rate of 1/2. The duration of one OFDM symbol is 8 μ s in 802.11p and depending on the modulation scheme and coding rate different numbers of data bits can be carried in each OFDM symbol, see Table B.1. The signal field consists of 24 bits transmitted with the lowest transfer rates and therefore it takes 8 μ s.

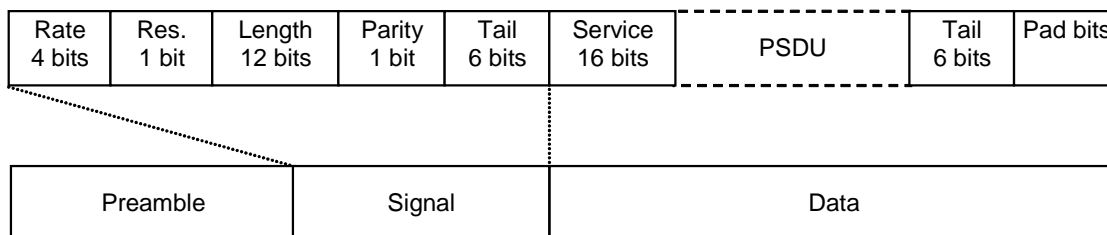

Figure B.1: The resulting PHY packet, i.e. PPDU, ready for transmission

In Table B.2 an explanation to all the different fields in the packet is given together with duration for 10 MHz frequency channels. The preamble and the signal field have fixed duration.

Table B.2: Explanation of the different fields of the PPDU

Field	Subfield	Description	Duration [μ s]
Preamble	N/A	Synchronizing receiver. Consists of a short and a long training sequence.	32
Signal	Rate	Specifies the transfer rate at which the data field in the PPDU will be transmitted.	8
	Reserved	For future use.	
	Length	The length of the packet.	
	Parity	Parity bit.	
Data	Tail	Used for facilitate decoding and calculation of rate and length subfields.	Depending on selected transfer rate and packet length.
	Service	Used for synchronizing the descrambler at receiver.	
	PSDU	The data from the MAC layer including header and trailer, i.e. MPDU.	
	Pad bits	Bits added to reach a multiple of coded bits per OFDM symbol (i.e. 48, 96, 192, 288, see Table B.1).	

More details about the PHY are found in clause 18 of IEEE 802.11 [3].

B.4 Medium access control

B.4.1 Introduction

The MAC algorithm decides when in time a node is allowed to transmit based on the current channel status and the MAC schedules transmission with the goal to minimize the interference in the system to increase the packet reception probability. The MAC algorithm deployed by 802.11p is found in the IEEE 802.11-2012 [3] and it is called enhanced distributed coordination access (EDCA). It is based on the basic distributed coordination function (DCF) but adds QoS attributes. DCF is a carrier sense multiple access with collision avoidance (CSMA/CA) algorithm.

NOTE: The EDCA was introduced with the IEEE 802.11e amendment and it added QoS to the DCF mechanism. IEEE 802.11e [i.13] was published in 2004 and it was enrolled into 802.11 in 2007, at which time the 802.11e document was classified as superseded.

In CSMA/CA a node starts to listen to the channel before transmission and if the channel is perceived as idle for a predetermined listening period the node can start to transmit directly. If the channel becomes occupied during the listening period the node will perform a backoff procedure, i.e. the node has to defer its access according to a randomized time period. In IEEE 802.11-2012, the predetermined listening period is called either arbitration interframe space (AIFS) or distributed interframe space (DIFS) depending upon the mode of operation (EDCA or DCF). The former listening period is used when there is support for QoS.

B.4.2 Backoff procedure

The backoff procedure in 802.11 works as follows:

- (i) draw an integer from a uniform distribution $[0, CW]$, where CW refers to the current maximum value of the contention window (the total number of integers to draw from is $CW+1$);
- (ii) decrease the backoff value only when the channel is free, one decrement per slot time (for a 10 MHz channel the slot time is 13 μ s);
- (iii) upon reaching a backoff value of 0, transmit. In broadcast operation the node will only invoke the backoff procedure once during the initial listening period. When 802.11 is employed in unicast mode it acts as a stop-and-wait protocol and the transmitter will wait for an acknowledgment (ACK). If no ACK is received by the sender for some reason (the transmitted packet never reached the intended recipient, the packet was incorrect at reception, or the ACK never reached the sender), a backoff procedure will also be invoked.

For every attempt to send a specific packet (in broadcast mode there is only one attempt but in unicast mode it can be several attempts due to missing ACKs), the current size of the contention window, CW , will be increased from its initial value (CW_{min}) until it reaches a maximum value (CW_{max}). This feature of increasing the CW allows the network to recover from high utilization periods by spreading transmission attempts in time. After a successful transmission or when the packet had to be discarded because the maximum number of channel access attempts was reached, the CW will be set to its initial value again (CW_{min}).

If the channel becomes busy during the decrease of the backoff value once per 13 μ s slot time the node has to suspend the countdown until the channel becomes free again. However, it should be noted that after every busy channel period the node will first wait an AIFS before the decrementation resumes.

NOTE: In broadcast mode the backoff procedure is only invoked once during the initial listening (AIFS) to the channel due to the lack of ACKs in broadcast transmissions. Therefore, the CW is always set to its minimum value, CW_{min} , and it will never be doubled.

More details about the backoff procedure are found in clauses 9.3.3, 9.3.4.3 and 9.19.2.5 of IEEE 802.11 [3].

B.4.3 Medium access control

In Figure B.2 simplified drawings of the channel access procedure as performed by 802.11 nodes is depicted for broadcast mode, Figure B.2(a), and unicast mode, Figure B.2(b).

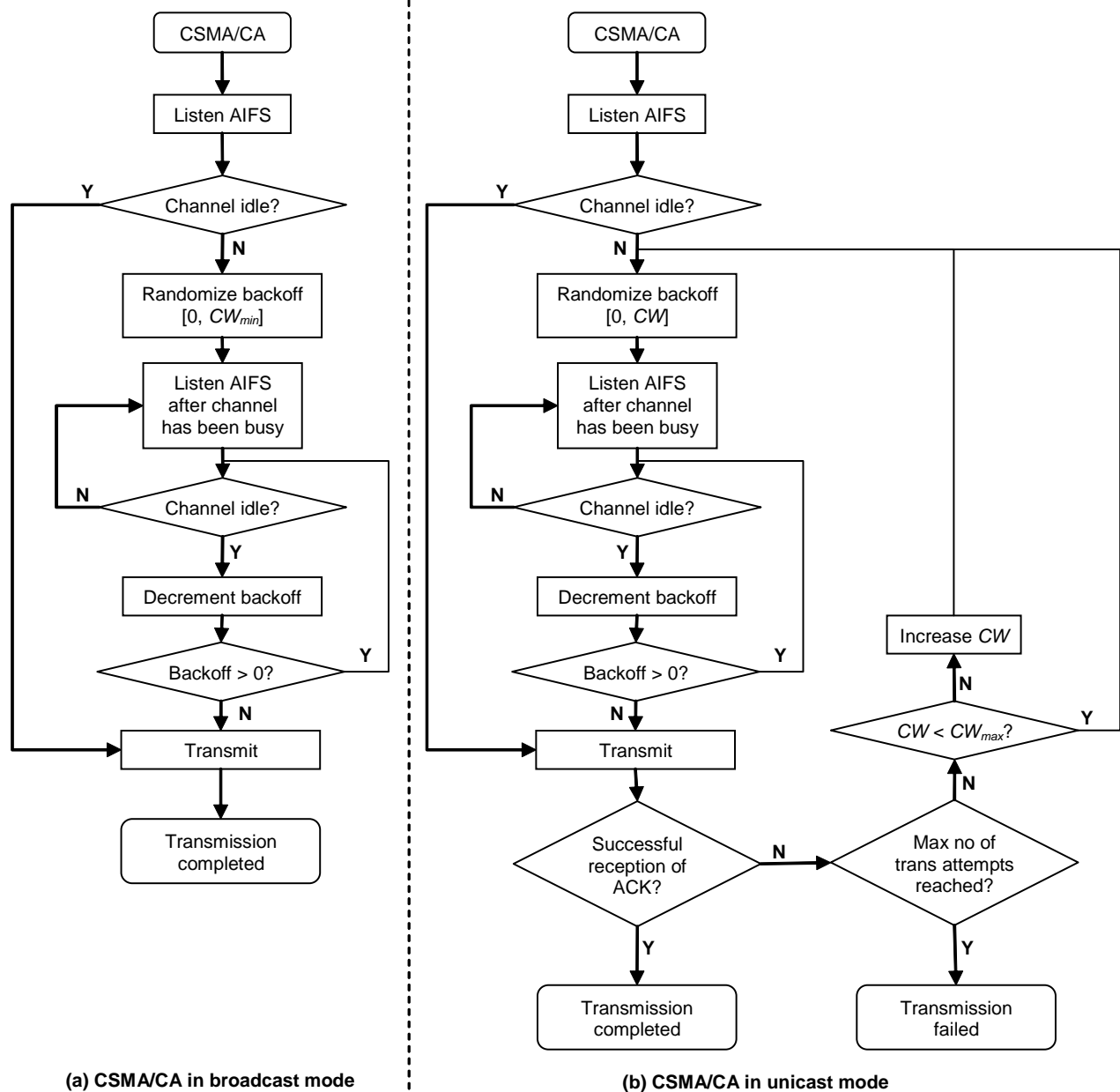

Figure B.2: A simplified drawing of the channel access procedure in IEEE 802.11-2012 in broadcast and unicast mode

More details about the channel access procedure are found in clause 9 of IEEE 802.11-2012 [3].

B.4.4 EDCA parameters, AC and UP

EDCA is the official name of one of the MAC algorithms in 802.11, which is used by 802.11p. It is the DCF with inclusion of QoS, i.e. the CSMA/CA algorithm with the possibility to prioritize data traffic. In EDCA every node maintain queues with different AIFS values and CW sizes with the purpose of giving data traffic with higher priority increased probability to access the channel before data traffic with lower priority.

The QoS facility in 802.11 defines eight different user priorities (UPs) and these are inherited from the ANSI/IEEE Std 802.1D [i.10] defining MAC bridges. The UPs from 802.1D are shown in Table B.3 and they are mapped to four different access categories (ACs), i.e. queues, within the QoS facility. This mapping is shown in Table B.3, where the lowest priority is 0 and the highest 7.

Table B.3: Mapping of UPs in 802.1D to the ACs of QoS facility in 802.11

UP in 802.1D	Data traffic type in 802.1D	AC in 802.11	Data traffic type in 802.11
1	Background (BK)	AC_BK	Background
2	Spare (-)	AC_BK	Background
0	Best effort (BE)	AC_BE	Best effort
3	Excellent effort (EE)	AC_BE	Best effort
4	Controlled load	AC_VI	Video
5	Video (VI)	AC_VI	Video
6	Voice (VO)	AC_VO	Voice
7	Network control (NC)	AC_VO	Voice

NOTE 1: In 802.1D best effort traffic has the lowest priority 0 but the traffic type background has the priority of 1 even if this traffic type in reality has lower priority than the best effort type. For historical reasons the priority of the best effort traffic in 802.1D is not changed because of interoperability problems with legacy network equipment. This priority conflict is however solved in the QoS facility in 802.11.

The resulting AIFS for the ACs is calculated using the following formula:

$$AIFS[AC] = AIFSN[N] \times aSlotTime + aSIFSTime \quad (B.1)$$

where the *AIFSN* stands for AIFS number, which is an integer, *aSlotTime* and the *aSIFSTime* (short interframe space) are fetched from the PHY in use and they are fixed. Consequently, the *AIFSN* is the parameter determining the listening period (AIFS) for each queue (AC). In Table B.4 the default values for *AIFSN* and *CW* is tabulated for the different ACs in 802.11p, found in Table 8-106 [3].

Table B.4: The default values for the AIFSN and CW in 802.11p [3]

AC	CW_{min}	CW_{max}	AIFSN
AC_VO	$(aCW_{min} + 1) / 4 - 1$	$(aCW_{min} + 1) / 2 - 1$	2
AC_VI	$(aCW_{min} + 1) / 2 - 1$	aCW_{min}	3
AC_BE	aCW_{min}	aCW_{max}	6
AC_BK	aCW_{min}	aCW_{max}	9

NOTE 2: The default values may be changed through some other mean such as the advertisement, regulation or another controlling standard.

In Table B.5 the different parameter values needed to determine MAC specific functions for 10 MHz channels of the OFDM PHY layer are tabulated. These values are fetched from Table 18-17 in [3].

Table B.5: OFDM PHY specific parameters used in 802.11p

Parameter	Value
<i>aSlotTime</i>	13 μ s
<i>aSIFSTime</i>	32 μ s
<i>aCWmin</i>	15
<i>aCWmax</i>	1 023

In Table B.6 the resulting default values for 802.11p's ACs are tabulated using Table B.4, Table B.5 and Equation (B.1).

Table B.6: The resulting AIFS and CW sizes for 802.11p's ACs

AC	CW_{min}	CW_{max}	AIFS
AC_VO	3	7	58 μ s
AC_VI	7	15	71 μ s
AC_BE	15	1 023	110 μ s
AC_BK	15	1 023	149 μ s

More details about the EDCA mechanism is found in clause 9.19.12 of IEEE 802.11 [3].

B.5 Implications of the dot11OCBActivated set to true

In 802.11p the new MIB variable `dot11OCBActivated` is introduced and when this is set to true certain features are disabled or given new default values in 802.11. The major change to the overall 802.11 standard is the possibility to exchange data frames without any prior network establishment, i.e. no authentication and association procedures are allowed at the MAC sublayer in 802.11p. The removal of these procedures affects many things because now there is no node that is responsible for determining network specific features such as power save mode, network id (basic service set identification, BSSID), security, synchronization, and negotiation about QoS. The following list is an excerpt of examples that is affected by the `dot11OCBActivated` is set true:

- MAC sublayer authentication and association procedures are disabled
- Power save is not allowed
- The BSSID is set to a wildcard containing only ones
- The traditional synchronization found in 802.11 is not possible because no beacons exist, however 802.11p also defines a new Timing Advertisement management frame type
- 802.11 Security needs association and authentication procedures and it is therefore not supported

NOTE: Security will be provided through other standards in the cooperative ITS domain and synchronization can be done using, e.g. GPS.

Annex C (informative): ITS-G5C frequency band

The usage of the ITS-G5C band, a.k.a. the RLAN/WLAN/BRAN band, situated between 5 470 MHz to 5 725 MHz is regulated in [i.17], which conditions are given in [i.5] and [i.6]. The regulation requires TPC, DFS, and uniform spreading of signals to avoid interfering with radar systems. A typical network topology for the usage of the RLAN band is an AP (master) with associated nodes (slaves) and here no DFS implementation is necessary for the slaves because the distance between master and slaves are typically short (and indoor). However, the broadband fixed wireless access in the 5,8 GHz band detailed in EN 302 502 [i.15] requires a full DFS implementation for all transmitters taking into account higher output power and larger communication distances. Mobile transmitters in vehicles probably fall in the same category. Even if a fixed ITS-G5 station (roadside unit, RSU) finds a frequency channel perceived to be radar "free", the mobile transmitter may not have the same perception when being for example on the border of the RSU's communication range.

The requirement of TPC and DFS is covered in IEEE 802.11-2012 [3] through the MIB parameter `dot11SpectrumManagementRequired` set to true. When setting the MIB parameter `dot11OCBActivated` to true, `dot11SpectrumManagementRequired` is false, thus the two modes of operation are mutually exclusive. Hence, communication outside the context of a basic service set is not possible in the ITS-G5C band. But short range communication with a fixed station in the context of a BSS in combination with spectrum management is possible (e.g. in a garage) even though not specified for ITS-G5 stations at time of preparation of the present document.

Annex D (informative): Bibliography

ETSI TR 102 654 (V1.1.1): "Electromagnetic compatibility and Radio spectrum Matters (ERM); Road Transport and Traffic Telematics (RTTT); Co-location and Co-existence Considerations regarding Dedicated Short Range Communication (DSRC) transmission equipment and Intelligent Transport Systems (ITS) operating in the 5 GHz frequency range and other potential sources of interference".

ECC/DEC/(08)01: "ECC Decision of 14 March 2008 on the harmonised use of the 5875-5925 MHz frequency band for Intelligent Transport Systems (ITS)".

ETSI TS 102 723-3: "Intelligent Transport Systems; OSI cross-layer topics; Part 3: Interface between management entity and access layer".

ETSI TR 102 960: "Intelligent Transport Systems (ITS); Mitigation techniques to avoid interference between European CEN Dedicated Short Range Communication (RTTT DSRC) equipment and Intelligent Transport Systems (ITS) operating in the 5 GHz frequency range; Evaluation of mitigation methods and techniques".

History

Document history		
V1.1.0	January 2010	Publication as ES 202 663
V1.2.0	November 2012	EN Approval Procedure AP 20130301: 2012-11-01 to 2013-03-01