

Final draft **ETSI EN 302 625** V1.1.1 (2009-05)

---

*Harmonized European Standard (Telecommunications series)*

**Electromagnetic compatibility  
and Radio spectrum Matters (ERM);  
5 GHz BroadBand Disaster Relief applications (BBDR);  
Harmonized EN covering the essential requirements  
of article 3.2 of the R&TTE Directive**

---



---

Reference

DEN/ERM-TGDMR-058

---

Keywords

broadband, emergency, radio, testing

**ETSI**

650 Route des Lucioles  
F-06921 Sophia Antipolis Cedex - FRANCE

Tel.: +33 4 92 94 42 00 Fax: +33 4 93 65 47 16

Siret N° 348 623 562 00017 - NAF 742 C  
Association à but non lucratif enregistrée à la  
Sous-Préfecture de Grasse (06) N° 7803/88

---

**Important notice**

Individual copies of the present document can be downloaded from:

<http://www.etsi.org>

The present document may be made available in more than one electronic version or in print. In any case of existing or perceived difference in contents between such versions, the reference version is the Portable Document Format (PDF). In case of dispute, the reference shall be the printing on ETSI printers of the PDF version kept on a specific network drive within ETSI Secretariat.

Users of the present document should be aware that the document may be subject to revision or change of status. Information on the current status of this and other ETSI documents is available at

<http://portal.etsi.org/tb/status/status.asp>

If you find errors in the present document, please send your comment to one of the following services:

[http://portal.etsi.org/chaicor/ETSI\\_support.asp](http://portal.etsi.org/chaicor/ETSI_support.asp)

---

**Copyright Notification**

No part may be reproduced except as authorized by written permission.  
The copyright and the foregoing restriction extend to reproduction in all media.

© European Telecommunications Standards Institute 2009.  
All rights reserved.

**DECT™**, **PLUGTESTS™**, **UMTS™**, **TIPHON™**, the TIPHON logo and the ETSI logo are Trade Marks of ETSI registered for the benefit of its Members.

**3GPP™** is a Trade Mark of ETSI registered for the benefit of its Members and of the 3GPP Organizational Partners.

**LTE™** is a Trade Mark of ETSI currently being registered

for the benefit of its Members and of the 3GPP Organizational Partners.

**GSM®** and the GSM logo are Trade Marks registered and owned by the GSM Association.

# Contents

Intellectual Property Rights .....	6
Foreword.....	6
Introduction .....	6
1 Scope .....	7
2 References .....	7
2.1 Normative references .....	7
2.2 Informative references.....	8
3 Definitions, symbols and abbreviations .....	8
3.1 Definitions .....	8
3.2 Symbols.....	9
3.3 Abbreviations .....	9
4 Technical requirements specifications .....	10
4.1 Environmental profile.....	10
4.2 Conformance requirements .....	10
4.2.1 Carrier frequencies.....	10
4.2.1.1 Definition .....	10
4.2.1.2 Limits .....	10
4.2.1.3 Conformance.....	10
4.2.2 Nominal channel bandwidth and occupied channel bandwidth .....	10
4.2.2.1 Definition .....	10
4.2.2.2 Limits .....	10
4.2.2.3 Conformance.....	10
4.2.3 RF output power and power spectral density.....	11
4.2.3.1 Definitions.....	11
4.2.3.2 Transmit power .....	11
4.2.3.3 Power spectral density.....	11
4.2.3.4 Limits .....	11
4.2.3.5 Conformance.....	11
4.2.4 Transmitter unwanted emissions outside the 5 GHz BBDR bands.....	11
4.2.4.1 Definition .....	11
4.2.4.2 Limits .....	11
4.2.4.3 Conformance.....	12
4.2.5 Transmitter unwanted emissions within the BBDR bands.....	12
4.2.5.1 Definition .....	12
4.2.5.2 Limits .....	12
4.2.5.3 Conformance.....	12
4.2.6 Receiver spurious emissions .....	12
4.2.6.1 Definition .....	12
4.2.6.2 Limits .....	12
4.2.6.3 Conformance.....	13
5 Testing for compliance with technical requirements.....	13
5.1 Conditions for testing .....	13
5.1.1 Normal and extreme test conditions.....	13
5.1.2 Test sequence.....	13
5.1.3 Test frequencies and operating modes .....	13
5.1.4 Antennas .....	14
5.1.5 Presentation of equipment .....	14
5.1.5.1 Testing of host connected equipment and plug-in radio devices.....	14
5.1.5.1.1 The use of a host or test jig for testing plug-in radio devices .....	14
5.1.5.1.2 Testing of combinations .....	14
5.1.5.1.2.1 Alternative A: General approach for combinations .....	14
5.1.5.1.2.2 Alternative B: For host equipment with a plug-in radio device .....	14
5.1.5.1.2.3 Alternative C: For combined equipment with a plug-in radio device .....	15

5.1.5.1.2.4	Alternative D: For equipment with multiple radios .....	15
5.1.5.1.2.4.1	The spurious emissions from each radio can be identified .....	15
5.1.5.1.2.4.2	The spurious emissions from each radio cannot be identified .....	15
5.2	Interpretation of the measurement results .....	15
5.3	Essential radio test suites .....	16
5.3.1	Product information .....	16
5.3.2	Carrier frequencies .....	16
5.3.2.1	Test conditions .....	16
5.3.2.2	Test methods .....	16
5.3.2.2.1	Conducted measurement .....	16
5.3.2.2.1.1	Equipment operating without modulation .....	16
5.3.2.2.1.2	Equipment operating with modulation .....	17
5.3.2.2.2	Radiated measurement .....	17
5.3.3	Occupied channel bandwidth .....	17
5.3.3.1	Test conditions .....	17
5.3.3.2	Test method .....	17
5.3.3.2.1	Conducted measurement .....	17
5.3.3.2.2	Radiated measurement .....	18
5.3.4	RF output power and Power Spectral Density (PSD) .....	18
5.3.4.1	Test conditions .....	18
5.3.4.2	Test method .....	18
5.3.4.2.1	Conducted measurement .....	18
5.3.4.2.1.1	RF Output Power .....	18
5.3.4.2.2	Radiated measurement .....	22
5.3.5	Transmitter unwanted emissions outside the BBDR bands .....	22
5.3.5.1	Test conditions .....	22
5.3.5.2	Test method .....	22
5.3.5.2.1	Conducted measurement .....	22
5.3.5.2.1.1	Pre-scan .....	22
5.3.5.2.1.2	Measurement of the emissions identified during the pre-scan .....	23
5.3.5.2.2	Radiated measurement .....	24
5.3.6	Transmitter unwanted emissions within the BBDR bands .....	24
5.3.6.1	Test conditions .....	24
5.3.6.2	Test method .....	25
5.3.6.2.1	Conducted measurement .....	25
5.3.6.2.1.1	Option 1: Using a spectrum analyser video averaging mode .....	25
5.3.6.2.1.2	Option 2: Using a spectrum analyser average detector .....	25
5.3.6.2.2	Radiated measurement .....	26
5.3.7	Receiver spurious emissions .....	26
5.3.7.1	Test conditions .....	26
5.3.7.2	Test method .....	26
5.3.7.2.1	Conducted measurement .....	26
5.3.7.2.1.1	Pre-scan .....	26
5.3.7.2.1.2	Measurement of the emissions identified during the pre-scan .....	27
5.3.7.2.2	Radiated measurement .....	27
<b>Annex A (normative):</b>	<b>HS Requirements and conformance Test specifications Table (HS-RTT) .....</b>	<b>28</b>
<b>Annex B (normative):</b>	<b>Test sites and arrangements for radiated measurements .....</b>	<b>30</b>
B.1	Test sites .....	30
B.1.1	Open air test sites .....	30
B.1.2	Anechoic chamber .....	31
B.1.2.1	General .....	31
B.1.2.2	Description .....	31
B.1.2.3	Influence of parasitic reflections .....	31
B.1.2.4	Calibration and mode of use .....	32
B.2	Test antenna .....	33
B.3	Substitution antenna .....	34

<b>Annex C (normative):</b>	<b>General description of measurement .....</b>	<b>35</b>
C.1	Conducted measurements .....	35
C.2	Radiated measurements .....	35
C.3	Substitution measurement .....	36
<b>Annex D (informative):</b>	<b>The EN title in the official languages .....</b>	<b>37</b>
<b>Annex E (informative):</b>	<b>Bibliography .....</b>	<b>38</b>
History .....		39

---

## Intellectual Property Rights

IPRs essential or potentially essential to the present document may have been declared to ETSI. The information pertaining to these essential IPRs, if any, is publicly available for **ETSI members and non-members**, and can be found in ETSI SR 000 314: "*Intellectual Property Rights (IPRs); Essential, or potentially Essential, IPRs notified to ETSI in respect of ETSI standards*", which is available from the ETSI Secretariat. Latest updates are available on the ETSI Web server (<http://webapp.etsi.org/IPR/home.asp>).

Pursuant to the ETSI IPR Policy, no investigation, including IPR searches, has been carried out by ETSI. No guarantee can be given as to the existence of other IPRs not referenced in ETSI SR 000 314 (or the updates on the ETSI Web server) which are, or may be, or may become, essential to the present document.

---

## Foreword

This Harmonized European Standard (Telecommunications series) has been produced by ETSI Technical Committee Electromagnetic compatibility and Radio spectrum Matters (ERM), and is now submitted for the Vote phase of the ETSI standards Two-step Approval Procedure.

The present document has been produced by ETSI in response to a mandate from the European Commission issued under Council Directive 98/34/EC [i.3] (as amended) laying down a procedure for the provision of information in the field of technical standards and regulations.

The present document is intended to become a Harmonized Standard, the reference of which will be published in the Official Journal of the European Communities referencing the Directive 1999/5/EC [i.1] of the European Parliament and of the Council of 9 March 1999 on radio equipment and telecommunications terminal equipment and the mutual recognition of their conformity ("the R&TTE Directive").

Technical specifications relevant to Directive 1999/5/EC [i.1] are given in annex A.

Equipment compliant with the present document can be intended for fitment into road vehicles, therefore it is subject to automotive EMC type approval and has to comply with Directive 95/54/EC [i.2]. For use on vehicles outside the scope of Directive 95/54/EC [i.2] compliance with an EMC directive/standard appropriate for that use is required.

<b>Proposed national transposition dates</b>	
Date of latest announcement of this EN (doa):	3 months after ETSI publication
Date of latest publication of new National Standard or endorsement of this EN (dop/e):	6 months after doa
Date of withdrawal of any conflicting National Standard (dow):	18 months after doa

---

## Introduction

The present document is part of a set of standards developed by ETSI and is designed to fit in a modular structure to cover all radio and telecommunications terminal equipment within the scope of the R&TTE Directive. The modular structure is shown in EG 201 399 [i.5].

# 1 Scope

The present document applies to equipment used in 5 GHz BroadBand Disaster Relief (BBDR) applications.

The equipment is used by Disaster Relief (DR) emergency services which require efficient rapid deployment of incident ad-hoc networks. Applications are used temporarily by emergency services in all aspects of disaster situations, including disaster prevention and post event scenarios. For instance, they provide incident communications, video or robotic data applications, telecommand and telemetry parameters, critical data base queries, field reporting, data and location information exchange.

NOTE: The frequency bands for BBDR applications are identified in ECC Recommendation (08)04 [i.4].

These radio equipment types are capable of operating in all or part of the frequency bands given in table 1.

**Table 1: Radiocommunications service frequency bands**

	<b>Radiocommunications service frequency bands</b>
Transmit	4 940 MHz to 4 990 MHz
Receive	4 940 MHz to 4 990 MHz
Transmit	5 150 MHz to 5 250 MHz
Receive	5 150 MHz to 5 250 MHz

The types of equipment covered by the present document are as follows:

- Base station Equipment (BE equipment fitted with integral or dedicated antenna(s), for use as a fixed, nomadic or mobile station).
- User Equipment (UE equipment fitted with integral or dedicated antenna(s), normally used as a mobile station).

# 2 References

References are either specific (identified by date of publication and/or edition number or version number) or non-specific.

- For a specific reference, subsequent revisions do not apply.
- Non-specific reference may be made only to a complete document or a part thereof and only in the following cases:
  - if it is accepted that it will be possible to use all future changes of the referenced document for the purposes of the referring document;
  - for informative references.

Referenced documents which are not found to be publicly available in the expected location might be found at <http://docbox.etsi.org/Reference>.

NOTE: While any hyperlinks included in this clause were valid at the time of publication ETSI cannot guarantee their long term validity.

## 2.1 Normative references

The following referenced documents are indispensable for the application of the present document. For dated references, only the edition cited applies. For non-specific references, the latest edition of the referenced document (including any amendments) applies.

- [1] ETSI TR 100 028 (2001) (all parts): "Electromagnetic compatibility and Radio spectrum Matters (ERM); Uncertainties in the measurement of mobile radio equipment characteristics".

- [2] CISPR 16 (2006), (parts 1-1, 1-4 and 1-5): "Specifications for radio disturbance and immunity measuring apparatus and methods".

## 2.2 Informative references

The following referenced documents are not essential to the use of the present document but they assist the user with regard to a particular subject area. For non-specific references, the latest version of the referenced document (including any amendments) applies.

- [i.1] Directive 1999/5/EC of the European Parliament and of the Council of 9 March 1999 on radio equipment and telecommunications terminal equipment and the mutual recognition of their conformity (R&TTE Directive).
- [i.2] Directive 95/54/EC of 31 October 1995 adapting to technical progress Council Directive 72/245/EEC on the approximation of the laws of the Member States relating to the suppression of radio interference produced by spark-ignition engines fitted to motor vehicles and amending Directive 70/156/EEC on the approximation of the laws of the Member States relating to the type-approval of motor vehicles and their trailers.
- [i.3] Council Directive 98/34/EC of the European Parliament and of the Council of 22 June 1998 laying down a procedure for the provision of information in the field of technical standards and regulations.
- [i.4] ECC Recommendation (08)04 on the identification of frequency bands for the implementation of BroadBand Disaster Relief (BBDR) radio applications in the 5 GHz frequency range.
- [i.5] ETSI EG 201 399 (V2.1.1): "Electromagnetic compatibility and Radio spectrum Matters (ERM); A guide to the production of candidate Harmonized Standards for application under the R&TTE Directive".

---

## 3 Definitions, symbols and abbreviations

### 3.1 Definitions

For the purposes of the present document, the terms and definitions given in the R&TTE Directive [i.1] and the following apply:

**5 GHz BBDR bands:** frequency bands from 4 940 MHz to 4 990 MHz and from 5 150 MHz to 5 250 MHz

**base station equipment:** radio equipment normally used as a hub or a gateway within the BBDR network to facilitate communication among devices within the network

**combined equipment:** any combination of non-radio equipment that requires a plug-in radio device to offer full functionality

**dedicated antenna:** antenna external to the equipment, using an antenna connector with a cable and which has been designed or developed for one or more specific types of equipment

NOTE: It is the combination of dedicated antenna and radio equipment that is expected to be compliant with the regulations.

**frequency band:** one of the frequency ranges defined in clause 1, table 1

**host equipment:** any equipment which has complete user functionality when not connected to the radio equipment part and to which the radio equipment part provides additional functionality and to which connection is necessary for the radio equipment part to offer functionality



**integral antenna:** antenna designed as a fixed part of the equipment, without the use of an external connector and as such which cannot be disconnected from the equipment by the user with the intent to connect another antenna

NOTE: An integral antenna may be fitted internally or externally. In the case where the antenna is external, a non-detachable cable not exceeding 3 m length is allowed.

**plug-in radio device:** radio equipment module intended to be used with or within host, combined or multi-radio equipment, using their control functions and power supply

**radiated measurements:** measurements which involve the absolute measurement of a radiated field

**stand-alone radio equipment:** equipment that is intended primarily as communications equipment and that is normally used on a stand-alone basis

**user equipment:** radio equipment normally used as a mobile station and which allows a user to communicate with other devices within the BBDR network

## 3.2 Symbols

For the purposes of the present document, the following symbols apply:

dB	deciBel
dBi	antenna gain relative to isotropic radiator in decibel
dBr	decibel relative to the maximum power
E	electrical field strength
f	frequency
$f_c$	nominal centre frequency
$f_H$	lower -6 dBr frequency
$f_L$	higher -6 dBr frequency
G	antenna gain
IF	Intermediate Frequency
P	equivalent isotropically radiated power level
R	distance
$T_{max}$	maximum temperature
$T_{min}$	minimum temperature
Tx on	effective transmitter on-time
Tx off	effective transmitter off-time
$V_{max}$	maximum voltage
$V_{min}$	minimum voltage
$\mu s$	microsecond
x	duty cycle

## 3.3 Abbreviations

For the purposes of the present document, the following abbreviations apply:

BBDR	BroadBand Disaster Relief
BE	Base station Equipment
DR	Disaster Relief
e.i.r.p.	equivalent isotropically radiated power
e.r.p.	effective radiated power
EC	European Commission
EMC	Electro Magnetic Compatibility
HS	Harmonized Standard
ppm	parts per million = $10^{-6}$
PSD	Power Spectral Density
RF	Radio Frequency
UE	User Equipment
UUT	Unit Under Test

---

## 4 Technical requirements specifications

### 4.1 Environmental profile

The technical requirements of the present document apply under the environmental profile for operation of the equipment, which shall be stated by the manufacturer. The equipment shall comply with all the technical requirements of the present document at all times when operating within the boundary limits of the stated operational environmental profile.

### 4.2 Conformance requirements

#### 4.2.1 Carrier frequencies

##### 4.2.1.1 Definition

The carrier frequencies are the centres of the channels on which the BBDR equipment can operate.

##### 4.2.1.2 Limits

The actual carrier frequency for any given channel shall be maintained within the range  $f_c \pm 20$  ppm.

##### 4.2.1.3 Conformance

Conformance tests as defined in clause 5.3.2 shall be carried out.

#### 4.2.2 Nominal channel bandwidth and occupied channel bandwidth

##### 4.2.2.1 Definition

The nominal channel bandwidth is the widest band of frequencies, inclusive of guard bands, assigned to a single channel.

The occupied channel bandwidth is the frequency bandwidth of the signal power at the -6 dBc points when measured with a 1 MHz resolution bandwidth.

NOTE: dBc is the spectral density relative to the maximum spectral power spectral density of the transmitted signal.

##### 4.2.2.2 Limits

The nominal bandwidth shall be in the range from 1,25 MHz to 20 MHz.

NOTE: The nominal channel bandwidth(s) applicable to the equipment is that declared by the manufacturer.

The occupied channel bandwidth shall be between 80 % and 100 % of the declared nominal channel bandwidth.

##### 4.2.2.3 Conformance

Conformance tests as defined in clause 5.3.3 shall be carried out to determine the occupied channel bandwidth.

## 4.2.3 RF output power and power spectral density

### 4.2.3.1 Definitions

### 4.2.3.2 Transmit power

The RF output power is defined as the total mean equivalent isotropically radiated power (e.i.r.p.) of the equipment during a transmission burst or transmission sequence.

### 4.2.3.3 Power spectral density

The Power Spectral Density (PSD) is the mean equivalent isotropically radiated power (e.i.r.p.) spectral density of the equipment during a transmission burst or transmission sequence.

### 4.2.3.4 Limits

The RF output power and the power spectral density shall not exceed the levels given table 2.

**Table 2: Mean e.i.r.p. limits for RF output power and power spectral density**

Equipment type	Mean e.i.r.p. limit	Mean e.i.r.p. density limit
Base Station Equipment (BE)	39 dBm	26 dBm/MHz
User Equipment (UE)	26 dBm	13 dBm/MHz

### 4.2.3.5 Conformance

Conformance tests as defined in clause 5.3.4 shall be carried out.

## 4.2.4 Transmitter unwanted emissions outside the 5 GHz BBDR bands

### 4.2.4.1 Definition

These are radio frequency emissions outside the 5 GHz BBDR bands.

### 4.2.4.2 Limits

The level of unwanted emission shall not exceed the limits given in table 3.

**Table 3: Transmitter unwanted emission limits outside the 5 GHz BBDR bands**

Frequency range	Maximum power, ERP	Bandwidth
30 MHz to 47 MHz	-36 dBm	100 kHz
47 MHz to 74 MHz	-54 dBm	100 kHz
74 MHz to 87,5 MHz	-36 dBm	100 kHz
87,5 MHz to 118 MHz	-54 dBm	100 kHz
118 MHz to 174 MHz	-36 dBm	100 kHz
174 MHz to 230 MHz	-54 dBm	100 kHz
230 MHz to 470 MHz	-36 dBm	100 kHz
470 MHz to 862 MHz	-54 dBm	100 kHz
862 MHz to 1 GHz	-36 dBm	100 kHz
1 GHz to 4,940 GHz	-30 dBm	1 MHz
4,990 GHz to 5,150 GHz	-30 dBm	1 MHz
5,250 GHz to 18 GHz	-30 dBm	1 MHz

### 4.2.4.3 Conformance

Conformance tests as defined in clause 5.3.5 shall be carried out.

## 4.2.5 Transmitter unwanted emissions within the BBDR bands

### 4.2.5.1 Definition

These are radio frequency emissions within the 5 GHz BBDR bands.

### 4.2.5.2 Limits

The average level of the transmitted unwanted emissions within the 5 GHz BBDR bands shall not exceed the limits provided by the mask in figure 1.

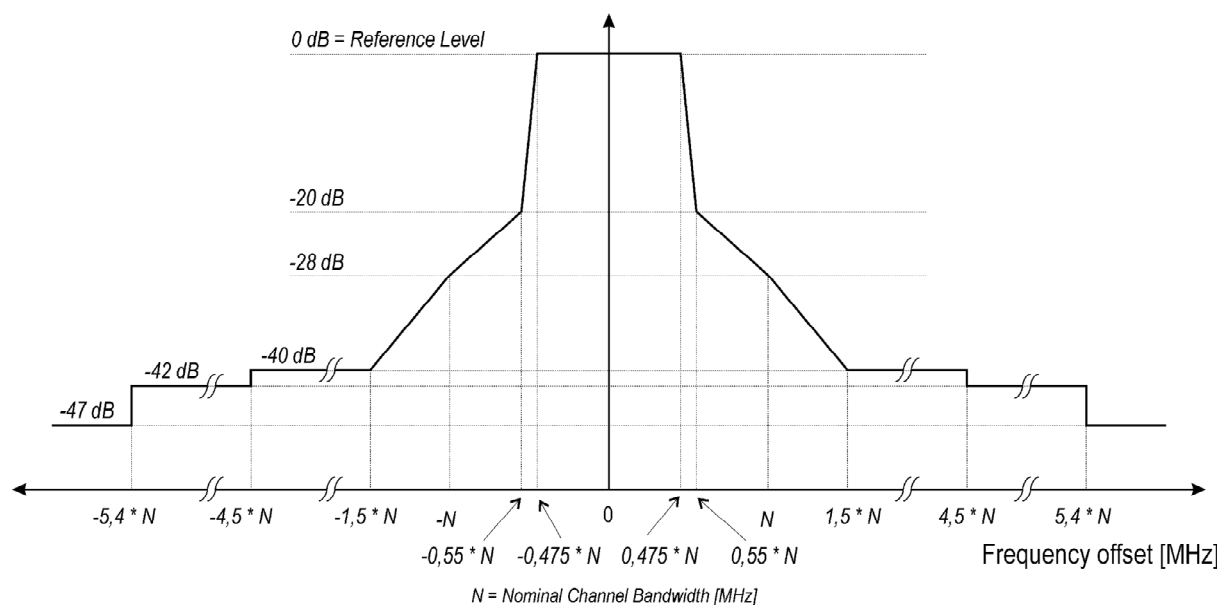

NOTE: dB is the power spectral density relative to the maximum power spectral density of the transmitted signal.

**Figure 1: Transmit spectral power mask**

Transmitter unwanted emissions within the 5 GHz BBDR bands shall not exceed the limit of the mask provided in figure 1 or the limit for unwanted emissions provided in table 3, whichever is the higher.

NOTE: The mask is only applicable within the band of operation. Beyond the band edges the requirements of clause 4.2.4 apply.

### 4.2.5.3 Conformance

Conformance tests as defined in clause 5.3.6 shall be carried out.

## 4.2.6 Receiver spurious emissions

### 4.2.6.1 Definition

Receiver spurious emissions are emissions at any frequency when the equipment is in receive mode.

### 4.2.6.2 Limits

The spurious emissions of the receiver shall not exceed the limits given in table 4.

**Table 4: Spurious radiated emission limits**

Frequency range	Maximum power	Measurement bandwidth
$30 \text{ MHz} \leq f < 1 \text{ GHz}$	-57 dBm (e.r.p.)	100 kHz
$1 \text{ GHz} \leq f \leq 18 \text{ GHz}$	-47 dBm (e.i.r.p.)	1 MHz

### 4.2.6.3 Conformance

Conformance tests as defined in clause 5.3.7 shall be carried out.

## 5 Testing for compliance with technical requirements

### 5.1 Conditions for testing

#### 5.1.1 Normal and extreme test conditions

Tests defined in the present document shall be carried out under normal test conditions and where stated, under the extreme test conditions as declared by the manufacturer (see clause 4.1).

#### 5.1.2 Test sequence

For the purpose of testing, the equipment may be capable of operating in a continuous transmit and/or receive mode.

If continuous transmit mode (100 % duty cycle) is not possible, then the equipment shall be configured to transmit a test sequence which shall be representative of normal use of the equipment.

The same test sequence shall be used for all measurements on the same equipment.

The test transmissions shall be fixed in length in a sequence and shall exceed the transmitter minimum activity ratio of 10 %. The minimum duration of the sequence shall be adequate for the test purposes.

The general structure of the test transmission sequence is shown in figure 2.

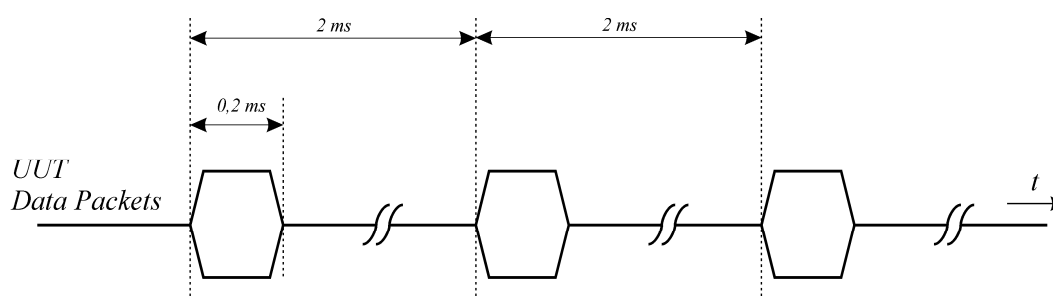

**Figure 2: General structure of the test transmission sequences**

#### 5.1.3 Test frequencies and operating modes

Some of the features of the equipment may need to be disabled in order to perform the tests. On the other hand the equipment may have special features or operating modes which may facilitate the testing.

The measurements for RF Output Power and Power Spectral Density (PSD) shall be performed at the lowest and highest carrier frequency for each of the stated frequency ranges. The measurements for transmitter unwanted emissions and the receiver spurious emissions shall be performed when operating on one of the carrier frequencies for each of the stated frequency ranges.

If the equipment has different nominal channel bandwidths, the measurements need to be repeated for each of the channel widths.

If the equipment can operate with different modulation schemes, the equipment shall be configured in that mode which is worse case for the test to be performed.

## 5.1.4 Antennas

The equipment can have either integral or dedicated antennas.

Dedicated antennas, further referred to as *dedicated external antennas*, are antennas that are physically external to the equipment and which are assessed in combination with the equipment against the requirements in the present document.

NOTE: It should be noted that assessment does not necessarily lead to testing.

An antenna assembly referred to in the present document is understood as the combination of the antenna (integral or dedicated), its coaxial cable and if applicable, its antenna connector and associated switching components.

Although the measurement methods in the present document allow conducted measurements to be performed, it should be noted that the equipment together with all its intended antenna assemblies shall comply with the applicable technical requirements defined in the present document.

## 5.1.5 Presentation of equipment

### 5.1.5.1 Testing of host connected equipment and plug-in radio devices

For combined equipment and for radio parts for which connection to or integration with host equipment is required to offer functionality to the radio, different alternative test approaches are permitted. Where more than one such combination is intended, testing shall not be repeated for combinations of the radio part and various host equipment where the latter are substantially similar.

Where more than one such combination is intended and the combinations are not substantially similar, one combination shall be tested against all requirements of the present document and all other combinations shall be tested separately for radiated spurious emissions only.

#### 5.1.5.1.1 The use of a host or test jig for testing plug-in radio devices

Where the radio part is a plug-in radio device which is intended to be used within a variety of combinations, a suitable test configuration consisting of either a test jig or typical host equipment shall be used. This shall be representative for the range of combinations in which the device may be used. The test jig shall allow the radio equipment part to be powered and stimulated as if connected to or inserted into host or combined equipment. Measurements shall be made to all requirements of the present document.

#### 5.1.5.1.2 Testing of combinations

##### 5.1.5.1.2.1 Alternative A: General approach for combinations

Combined equipment or a combination of a plug-in radio device and a specific type of host equipment may be used for testing according to the full requirements of the present document.

##### 5.1.5.1.2.2 Alternative B: For host equipment with a plug-in radio device

A combination of a plug-in radio device and a specific type of host equipment may be used for testing according to the full requirements of the present document.

For radiated spurious emission tests the most appropriate standard shall be applied to the host equipment. The plug-in radio device shall meet the radiated spurious emissions requirements as described in the present document.

#### 5.1.5.1.2.3 Alternative C: For combined equipment with a plug-in radio device

Combined equipment may be used for testing according to the full requirements of the present document.

For radiated spurious emissions the requirements of the most appropriate harmonized EMC standard shall be applied to the no radio equipment. The plug-in radio device shall meet the radiated spurious emissions requirements as described in the present document.

In the case where the plug-in radio device is totally integrated and cannot operate independently, radiated spurious emissions for the combination shall be tested using the most appropriate harmonized standard with the radio part in receive and/or standby mode. If the frequency range is less than the one defined in the present document, additional measurements according to the requirements in the present document shall be performed to cover the remaining parts of the frequency range. With the radio in transmit mode, the radiated spurious emissions requirements of the present document shall be applied.

#### 5.1.5.1.2.4 Alternative D: For equipment with multiple radios

Multi-radio equipment, where at least one of the radio parts is within the scope of the present document, may be used for testing according to the full requirements of the present document. Additional requirements and limits for multi-radio equipment are set out in the relevant harmonized radio product standards applicable to the other radio parts.

When measuring spurious emissions in the receive and/or standby mode, it is essential that none of the transmitters within the combined equipment are transmitting.

##### 5.1.5.1.2.4.1 The spurious emissions from each radio can be identified

Where the spurious emissions from each radio can be identified, then the spurious emissions from each radio are assessed to the relevant harmonized radio standard.

##### 5.1.5.1.2.4.2 The spurious emissions from each radio cannot be identified

Where the spurious emissions from each radio cannot be identified, then the combined equipment is assessed to the spurious emission requirements contained in all of the relevant harmonized radio standards applicable to the radios contained within the combined product.

Where the applicable harmonized radio standards contain different limits and measuring conditions, then the combined product is assessed to the harmonized radio standard that specifies the least stringent limits for the common part of the frequency measurement ranges. To assess the remaining parts of the frequency measurement ranges the limits from the relevant harmonized radio standard should be used.

## 5.2 Interpretation of the measurement results

The interpretation of the results recorded in a test report for the measurements described in the present document shall be as follows:

- the measured value related to the corresponding limit shall be used to decide whether an equipment meets the requirements of the present document;
- the value of the measurement uncertainty for the measurement of each parameter shall be separately included in the test report;
- the recorded value of the measurement uncertainty shall be, for each measurement, equal to or lower than the figures in table 5.

The measurement uncertainty figures shall be calculated in accordance with TR 100 028 [1] and shall correspond to an expansion factor (coverage factor)  $k = 1,96$  or  $k = 2$  (which provide confidence levels of respectively 95 % and 95,45 % in the case where the distributions characterizing the actual measurement uncertainties are normal (Gaussian)).

Table 5 is based on such expansion factors.

**Table 5: Maximum measurement uncertainty**

Parameter	Uncertainty
RF frequency	$\pm 1 \times 10^{-5}$
RF power conducted	$\pm 1,5$ dB
RF power radiated	$\pm 6$ dB
Humidity	$\pm 5$ %
Temperature	$\pm 1$ °C

## 5.3 Essential radio test suites

### 5.3.1 Product information

The following information is necessary in order to carry out the test suites:

- the type of modulation(s) used;
- the operating frequency range(s) of the equipment;
- for each of the frequency ranges, the operating nominal carrier frequencies and corresponding nominal channel bandwidth(s) of the equipment;
- the type of the antenna: integral or dedicated;
- the intended combination(s) of the radio equipment power settings and one or more antenna assemblies and their corresponding e.i.r.p. spectral density levels;
- the normal and the extreme operating conditions (e.g. voltage and temperature) that apply to the equipment;
- the type of equipment, for example: stand-alone equipment, plug-in radio device, combined equipment, etc.;
- the test sequence used during the testing.

### 5.3.2 Carrier frequencies

#### 5.3.2.1 Test conditions

These measurements shall be performed under normal test conditions.

For a UUT with antenna connector(s) and using dedicated external antenna(s), or for a UUT with integral antenna(s) but with a temporary antenna connector provided, conducted measurements shall be used.

For a UUT with integral antenna(s) and without a temporary antenna connector, radiated measurements shall be used.

#### 5.3.2.2 Test methods

##### 5.3.2.2.1 Conducted measurement

###### 5.3.2.2.1.1 Equipment operating without modulation

This test method requires that the UUT can be operated in an un-modulated test mode.

The UUT shall be connected to a frequency counter and operated in an un-modulated mode. The result shall be compared with declared carrier frequency for this channel to calculate the carrier frequency error which shall be recorded.



#### 5.3.2.2.1.2 Equipment operating with modulation

This method is an alternative to the above method in case the UUT cannot be operated in an un-modulated mode.

The UUT shall be connected to the spectrum analyser.

The settings of the spectrum analyser shall be adjusted to optimize the instruments frequency accuracy.

The Max Hold function shall be selected and the centre frequency shall be adjusted to the current carrier frequency of the UUT.

The peak value of the power envelope shall be measured and recorded. The Frequency Span of the spectrum analyser shall be reduced and the marker shall be moved in a positive frequency increment until the upper, (relative to the centre frequency), -10 dBc point is reached. This value shall be noted as f1.

The marker shall then be moved in a negative frequency increment until the lower, (relative to the centre frequency), -10 dBc point is reached. This value shall be noted as f2.

The centre frequency is calculated as  $(f1 + f2)/2$ . This value shall be compared with declared carrier frequency for this channel to calculate the carrier frequency error which shall be recorded.

#### 5.3.2.2.2 Radiated measurement

The test set up as described in annex B shall be used with a spectrum analyser of sufficient accuracy attached to the test antenna.

The test procedure is as described under clause 5.3.2.2.1.

### 5.3.3 Occupied channel bandwidth

#### 5.3.3.1 Test conditions

This measurement shall be performed under normal test conditions.

The UUT shall be configured to operate at a normal RF power output level.

For a UUT with antenna connector(s) and using dedicated external antenna(s), or for a UUT with integral antenna(s) but with a temporary antenna connector provided, conducted measurements shall be used.

For a UUT with integral antenna(s) and without a temporary antenna connector, radiated measurements shall be used.

#### 5.3.3.2 Test method

##### 5.3.3.2.1 Conducted measurement

###### Step 1:

Connect the UUT to the spectrum analyser and use the following settings:

- Centre Frequency: The centre frequency of the channel under test
- Resolution BW: 100 kHz
- Video BW: 100 kHz
- Frequency Span: 2 x Nominal Bandwidth (e.g. 40 MHz for a 20 MHz channel)
- Detector Mode: Peak
- Trace Mode: Max Hold

**Step 2:**

When the trace on the spectrum analyser is complete, capture the trace, for example using the "View" option on the spectrum analyser.

Find the peak value of the trace and place the analyser marker on this peak.

**Step 3:**

Use a second marker of the spectrum analyser and find the frequency below the operating frequency at which the level is 6 dB below the level of the 1<sup>st</sup> marker. This frequency shall be recorded as  $f_L$ .

**Step 4:**

Use a third marker of the spectrum analyser and find the frequency above the operating frequency at which the level is 6 dB below the level of the 1<sup>st</sup> marker. This frequency shall be recorded as  $f_H$ .

**Step 5:**

The difference between the frequencies measured ( $f_H - f_L$ ) is the Occupied Channel Bandwidth which shall be recorded.

**5.3.3.2.2 Radiated measurement**

The test set up as described in annex B and the applicable measurement procedures described in annex C shall be used.

The test procedure is as described under clause 5.3.3.2.1.

**5.3.4 RF output power and Power Spectral Density (PSD)****5.3.4.1 Test conditions**

For a UUT with antenna connector(s) and using dedicated external antenna(s), or for a UUT with integral antenna(s) but with a temporary antenna connector provided, conducted measurements shall be used.

For a UUT with integral antenna(s) and without a temporary antenna connector, radiated measurements shall be used.

The UUT shall be configured to operate at the highest stated transmitter output power level.

**5.3.4.2 Test method****5.3.4.2.1 Conducted measurement****5.3.4.2.1.1 RF Output Power**

These measurements shall be performed under both normal and extreme test conditions.

**Step 1:**

- a) using suitable attenuators, the output power of the transmitter shall be coupled to a matched diode detector or equivalent thereof. The output of the diode detector shall be connected to the vertical channel of an oscilloscope;
- b) the combination of the diode detector and the oscilloscope shall be capable of faithfully reproducing the duty cycle of the transmitter output signal;
- c) the observed duty cycle of the transmitter (Tx on/(Tx on + Tx off)) shall be noted as  $x$  ( $0 < x \leq 1$ ), and recorded in the test report. For the purpose of testing, the equipment shall be operated with a duty cycle that is equal to or greater than 0,1 (see clause 5.1.2).

**Step 2:**

- a) the RF output power of the transmitter shall be determined using a wideband calibrated RF power meter with a matched thermocouple detector or an equivalent thereof and with an integration period that exceeds the repetition period of the transmitter by a factor 5 or more. The observed value shall be noted as "A" (in dBm);
- b) the e.i.r.p. (P) shall be calculated from the above measured power output A (in dBm), the observed duty cycle x, and the stated antenna gain "G" in dBi, according to the formula in c). If more than one antenna assembly is intended the gain of the antenna assembly with the highest gain shall be used;
- c)  $P = A + G + 10 \log (1/x)$  (dBm);
- d) P shall be recorded in the test report.

#### 5.3.4.2.1.2 Power Spectral Density

These measurements need only to be performed at normal test conditions.

For the purpose of this test, the minimum transmitter on-time shall be 10  $\mu$ s.

The transmitter shall be connected to the measuring equipment via a suitable attenuator and the power spectral density as defined shall be measured and recorded.

The power spectral density shall be determined using a spectrum analyser of adequate bandwidth in combination with an RF power meter.

Connect an RF power meter to the narrow IF output of the spectrum analyser and correct its reading using a known reference source, e.g. a signal generator.

NOTE 1: The IF output of the spectrum analyser may be 20 dB or more below the input level of the spectrum analyser. Unless the power meter has adequate sensitivity, a wideband amplifier may be required.

Different options for measuring the power spectral density are offered within the present document. The method used shall be documented in the test report.

The power spectral density to be measured is the highest mean power level found in any 1 MHz band.

Option 1: Using a spectrum analyser with an average detector and/or PSD measurement feature

**Step 1:**

Connect the UUT to the spectrum analyser and use the following settings:

- Centre Frequency: The centre frequency of the channel under test
- Resolution BW: 1 MHz
- Video BW: 1 MHz
- Frequency Span: 2 x Nominal Bandwidth (e.g. 40 MHz for a 20 MHz channel)
- Detector Mode: Peak
- Trace Mode: Max Hold

**Step 2:**

When the trace is complete, find the peak value of the power envelope and record the frequency.

**Step 3:**

Make the following changes to the settings of the spectrum analyser:

- Centre Frequency: Equal to the frequency recorded in step 2
- Frequency Span: 3 MHz

NOTE 2: For nominal channel band widths below 10 MHz, the span may need to be further reduced.

- Resolution BW: 1 MHz
- Video BW: 1 MHz
- Sweep Time: 1 minute
- Detector Mode: Average
- Trace Mode: Max Hold

NOTE 3: The detector mode "Average" is often referred to as "RMS Average" but do not use Video Average.

#### Step 4:

When the trace is complete, the trace shall be captured using the "Hold" or "View" option on the spectrum analyser.

Find the peak value of the trace and place the analyser marker on this peak. This level is recorded as the highest mean power (power spectral density) PSD in a 1 MHz band.

Alternatively, where a spectrum analyser is equipped with a function to measure power spectral density, this function may be used to display the power spectral density PSD in dBm/MHz.

In case of conducted measurements on smart antenna systems operating in a mode with multiple transmit chains active simultaneously, the power spectral density of each transmit chain shall be measured separately to calculate the total power spectral density (value "PSD" in dBm/MHz) for the UUT.

#### Step 5:

The maximum power spectral density e.i.r.p. is calculated from the above measured power spectral density (PSD), the observed duty cycle  $x$  (see clause 5.3.4.2.1.1 step 1), the applicable antenna assembly gain "G" in dBi according to the formula below. If more than one antenna assembly is intended, the gain of the antenna assembly with the highest gain shall be used.

- $PSD = D + G + 10 \log (1/x)$ ;
- PSD shall be recorded in the test report.

Option 2: Using a spectrum analyser with an narrow IF output port

#### Step 1:

Use the following settings for the spectrum analyser:

- Centre Frequency: The centre frequency of the channel under test
- Resolution BW: 1 MHz
- Video BW: 1 MHz
- Frequency Span: 2 x Nominal Bandwidth (e.g. 40 MHz for a 20 MHz channel)
- Detector Mode: Peak
- Trace Mode: Max Hold

#### Step 2:

Connect the UUT to the spectrum analyser and switch on the UUT.

#### Step 3:

Adjust the Reference Level of the Spectrum Analyser so that the peak of the power envelope is between the Reference Level and the Reference Level -10 dB with the amplitude scale set to 10 dB/div.

**Step 4:**

When the trace is complete, find the peak value of the power envelope using a marker.

The centre frequency of the spectrum analyser shall be set to the marker frequency. The span shall be further reduced to 1 MHz and the frequency of the highest power output shall be found. The frequency and level shall be recorded.

**Step 5:**

Change the settings of the spectrum analyser as follows:

- Centre Frequency: Equal to the frequency recorded in step 4
- Resolution BW: 1 MHz
- Video BW: 1 MHz
- Detector Mode: Peak
- Trace Mode: Max Hold
- Averaging: off
- Span: zero Hz

**Step 6:**

Connect a Power Meter to the "Narrow I.F." output port of the Spectrum Analyser.

NOTE 3a: The IF output of the spectrum analyser may be 20 dB or more below the input level of the spectrum analyser. Unless the power meter has adequate sensitivity, a wideband amplifier may be required.

Fine tune the Centre Frequency of the spectrum analyser for the highest indication on the power meter.

The level measured by the power meter shall be recorded as level "A".

It is important not to change any of the spectrum analyser settings beyond this stage.

**Step 7:**

Switch off the UUT and disconnect it from the spectrum analyser.

Connect an RF signal generator to the Spectrum Analyser and adjust the level and frequency of the signal generator to the values recorded in step 4.

NOTE 4: It is advisable to use the same cable which was connected before to the UUT.

Fine tune the frequency of the generator for the highest indication on the power meter. This to ensure that the frequency of the signal generator is identical to the centre frequency of the analyser.

Adjust the level of the generator to get the same indication on the power meter as the level "A" noted in step 6.

The level of the signal generator is now equal to the measured power spectral density (PSD). Depending on the accuracy of the level indication on the signal generator, a power meter may be used to accurately measure the current power (density) level (D) of the generator.

The mean power spectral density e.i.r.p. is calculated from the above measured power spectral density (PSD), the observed duty cycle  $x$  (see clause 5.3.4.2.1.1, step 1), the applicable antenna assembly gain "G" in dBi, according to the formula below. If more than one antenna assembly is intended, the gain of the antenna assembly with the highest gain shall be used:

- $PSD = D + G + 10 \log (1/x)$ ;
- PSD shall be recorded in the test report.

Where the spectrum analyser bandwidth is non-Gaussian, a suitable correction factor shall be determined and applied.

### 5.3.4.2.2 Radiated measurement

When performing radiated measurements on a UUT with a directional antenna, the UUT shall be configured/positioned for maximum e.i.r.p. in the horizontal plane.

A test site as described in annex B and using the applicable measurement procedures as described in annex C shall be used.

The test procedure is further as described under clause 5.3.4.2.1.

For measuring the RF output power, it is likely that a radiated measurement would be performed using a spectrum analyser or measurement receiver, rather than a wide band power sensor. If this is the case and if the resolution bandwidth capability of the measurement device is narrower than the occupied bandwidth of the UUT signal measured, then the method of measurement shall be documented in the test report.

## 5.3.5 Transmitter unwanted emissions outside the BBDR bands

### 5.3.5.1 Test conditions

The measurements shall be performed under normal test conditions. The UUT shall be configured to operate at the highest stated power level.

For UUT without an integral antenna and for a UUT with an integral antenna but with a temporary antenna connector, one of the following options shall be used:

- a) the level of unwanted emissions shall be measured as their power in a specified load (conducted unwanted emissions) and their radiated power when radiated by the cabinet or structure of the equipment with the antenna connector terminated by a specified load (cabinet radiation); or
- b) the level of unwanted emissions shall be measured as their radiated power when radiated by cabinet and antenna.

In the case where the UUT has an integral antenna, but no temporary antenna connector, only radiated measurements shall be used.

### 5.3.5.2 Test method

#### 5.3.5.2.1 Conducted measurement

The UUT shall be connected to a spectrum analyser capable of RF power measurements.

If possible, the UUT shall be set to continuous transmit (duty cycle = 1) for the duration of this test.

If continuous transmit is not possible, the UUT should be configured to operate at its maximum duty cycle.

##### 5.3.5.2.1.1 Pre-scan

The test procedure below shall be used to identify potential unwanted emissions of the UUT.

#### **Step 1:**

The sensitivity of the spectrum analyser should be such that the noise floor is at least 6 dB below the limits given in clause 4.2.4, table 3.

#### **Step 2:**

The emissions shall be measured over the range 30 MHz to 1 000 MHz.

Spectrum analyser settings:

- Resolution bandwidth: 100 kHz
- Video bandwidth: 100 kHz

- Detector mode: Peak
- Trace Mode: Max Hold
- Sweep time: For non continuous transmissions (duty cycle less than 100 %), the sweep time shall be sufficiently long, such that for each 100 kHz frequency step, the measurement time is greater than two transmissions of the UUT.

NOTE 1: E.g. for non continuous transmissions, if the UUT is using a test sequence as described in clause 5.1.2.1 (transmitter on + off time of 2 ms), then the sweep time has to be greater than 4 ms per 100 kHz. In this case, a full sweep from 30 MHz to 1 000 MHz would result in a sweep time of at least 39 s.

Any emissions identified during the sweeps above and that fall within the 6 dB range below the applicable limit, shall be individually measured using the procedure in clause 5.3.5.2.1.2 and compared to the limits given in clause 4.2.4, table 3.

### Step 3:

The emissions shall now be measured over the ranges:

- 1 GHz to 4,940 GHz
- 4,990 GHz to 5,000 GHz
- 5,000 GHz to 5,150 GHz
- 5,250 GHz to 18 GHz

Spectrum analyser settings:

- Resolution bandwidth: 1 MHz
- Video bandwidth: 1 MHz
- Detector mode: Peak
- Trace Mode: Max Hold
- Sweep time: For non continuous transmissions (duty cycle less than 100 %), the sweep time shall be sufficiently long, such that for each 1 MHz frequency step, the measurement time is greater than two transmissions of the UUT.

NOTE 2: E.g. for non continuous transmissions, if the UUT is using a test sequence as described in clause 5.1.2 (transmitter on + off time of 2 ms), then the sweep time has to be greater than 4 ms per 1 MHz. In this case, a full sweep of 1 GHz would result in a sweep time of at least 4 s.

NOTE 3: For these pre-scan measurements, the band 4 990 MHz to 5 000 MHz should be monitored for an extended period of time, e.g. by using a sweep time of 30 s or more.

Any emissions identified during the sweeps above that fall within the 6 dB range below the applicable limit, shall be individually measured using the procedure in clause 5.3.4.2.1.2 and compared to the limits given in clause 4.2.4, table 3.

#### 5.3.5.2.1.2 Measurement of the emissions identified during the pre-scan

The limits for unwanted emissions in clause 4.2.4 refer to average power levels.

The steps below shall be used to accurately measure the individual unwanted emissions identified during the pre-scan measurements above.

#### Continuous transmit signals:

For continuous transmit signals, a simple measurement using the Video Average detector of the spectrum analyser is permitted. The measured values shall be recorded and compared with the limits in clause 4.2.4.

**Non-continuous transmit signals:**

For non-continuous transmit signals, the measurement shall be made only over the "on" part of the burst.

**Step 1:**

The level of the emissions shall be measured in the time domain, using the following spectrum analyser settings:

- Centre Frequency: Frequency of emission identified during the pre-scan
- Resolution Bandwidth: 100 kHz (< 1 GHz) / 1 MHz (> 1 GHz)
- Video Bandwidth: 100 kHz (< 1 GHz) / 1 MHz (> 1 GHz)
- Frequency Span: 0 Hz
- Sweep Time: Suitable to capture one transmission burst
- Trigger: Video Trigger
- Detector: Peak
- Trace Mode: Clear Write

Adjust the centre frequency (fine tune) to capture the highest level of one burst or sequence of the emission to be measured.

**Step 2:**

Change the following setting on the spectrum analyser:

- Detector Video Average, minimum of 100 sweeps

The measured value is the average power of this emission during the on-time of the burst. The value shall be recorded and compared with the limit in clause 4.2.4.

**5.3.5.2.2 Radiated measurement**

The test set up as described in annex B shall be used with a spectrum analyser of sufficient accuracy attached to the test antenna (see clause 5.2).

The test procedure is as described under clause 5.3.5.2.1.

**5.3.6 Transmitter unwanted emissions within the BBDR bands****5.3.6.1 Test conditions**

The measurements shall be performed under normal test conditions. The UUT shall be configured to operate at the highest stated power level.

For UUT without an integral antenna and for a UUT with an integral antenna but with a temporary antenna connector, one of the following options shall be used:

- a) the level of unwanted emissions shall be measured as their power in a specified load (conducted unwanted emissions) and their radiated power when radiated by the cabinet or structure of the equipment with the antenna connector terminated by a specified load (cabinet radiation); or
- b) the level of unwanted emissions shall be measured as their radiated power when radiated by cabinet and antenna.

In the case where the UUT has an integral antenna, but no temporary antenna connector, only radiated measurements shall be used.



## 5.3.6.2 Test method

### 5.3.6.2.1 Conducted measurement

#### 5.3.6.2.1.1 Option 1: Using a spectrum analyser video averaging mode

The UUT shall be configured for continuous transmit mode (duty cycle equal to 100 %). If this is not possible, than option 2 shall be used.

##### **Step 1: Determination of the reference average power level**

Spectrum analyser settings:

- Resolution bandwidth: 1 MHz
- Video bandwidth: 30 kHz
- Detector mode: Peak
- Trace mode: Video Average
- Sweep Time: Coupled
- Centre Frequency: Centre frequency of the channel being tested
- Span: 2 times the Nominal Channel Bandwidth

Use the marker to find the highest average power level of the power envelope of the UUT. This level shall be used as the reference level for the relative measurements.

##### **Step 2: Determination of the relative average power levels**

Adjust the frequency range of the spectrum analyser to allow the measurement to be performed within the BBDR bands 4 940 MHz to 4 990 MHz and 5 150 MHz to 5 250 MHz. No other parameter of the spectrum analyser should be changed.

Compare the relative power envelope of the UUT with the spectrum mask given in clause 4.2.5.

#### 5.3.6.2.1.2 Option 2: Using a spectrum analyser average detector

This method shall be used if the UUT is not capable of operating in a continuous transmit mode (duty cycle less than 100 %). In addition, this option can also be used as an alternative to option 1 for systems operating in a continuous transmit mode.

##### **Step 1: Determination of the reference average power level**

Spectrum analyser settings:

- Resolution bandwidth: 1 MHz
- Video bandwidth: 30 kHz
- Detector mode: Average (see note)
- Trace Mode: Max Hold
- Sweep time:  $\geq 1$  minute
- Centre Frequency: Centre frequency of the channel being tested
- Span: 2 times the Nominal Channel Bandwidth

NOTE: The spectrum analyser Average Detector has to be used. Do not use Video Average.

Use the marker to find the highest average power level of the power envelope of the UUT. This level shall be used as the reference level for the relative measurements.

### **Step 2: Determination of the relative average power levels**

Adjust the frequency range of the spectrum analyser to allow the measurement to be performed within BBDR bands 4 940 MHz to 4 990 MHz and 5 150 MHz to 5 250 MHz. No other parameter of the spectrum analyser should be changed.

Compare the relative power envelope of the UUT with the spectrum mask given in clause 4.2.5.

#### **5.3.6.2.2 Radiated measurement**

The test set up as described in annex B shall be used with a spectrum analyser of sufficient accuracy attached to the test antenna (see clause 5.2).

The test procedure is as described under clause 5.3.6.2.1.

### **5.3.7 Receiver spurious emissions**

#### **5.3.7.1 Test conditions**

The measurement shall be performed under normal test conditions.

For UUT without an integral antenna and for a UUT with an integral antenna but with a temporary antenna connector, one of the following options shall be used:

- a) the level of spurious emissions shall be measured as their power in a specified load (conducted spurious emissions) and their radiated power when radiated by the cabinet or structure of the equipment with the antenna connector terminated by a specified load (cabinet radiation); or
- b) the level of spurious emissions shall be measured as their radiated power when radiated by cabinet and antenna.

In the case where the UUT has an integral antenna, but no temporary antenna connector, only radiated measurements shall be used.

#### **5.3.7.2 Test method**

##### **5.3.7.2.1 Conducted measurement**

The test method below assumes, that for the duration of the test, the UUT is configured into a continuous receive mode, or is operated in a mode where no transmissions occur.

###### **5.3.7.2.1.1 Pre-scan**

The test procedure below shall be used to identify potential receiver spurious emissions of the UUT.

#### **Step 1:**

The sensitivity of the spectrum analyser should be such that the noise floor is at least 6 dB below the limits given in clause 4.2.6.

#### **Step 2:**

The emissions shall be measured over the range 30 MHz to 1 000 MHz.

Spectrum analyser settings:

- Resolution bandwidth: 100 kHz
- Video bandwidth: 100 kHz

- Detector mode: Peak
- Trace Mode: Max Hold

Any emissions identified that fall within the 6 dB range below the applicable limit, shall be individually measured using the procedure in clause 5.3.6.2.1.2 and compared to the limits given in clause 4.2.6.

### Step 3:

The emissions shall now be measured over the range 1 GHz to 18 GHz.

Spectrum analyser settings:

- Resolution bandwidth: 1 MHz
- Video bandwidth: 1 MHz
- Detector mode: Peak
- Trace mode: Max Hold

Any emissions identified that fall within the 6 dB range below the applicable limit, shall be individually measured using the procedure in clause 5.3.6.2.1.2 and compared to the limits given in clause 4.2.6.

#### 5.3.7.2.1.2 Measurement of the emissions identified during the pre-scan

The limits for receiver spurious emissions in clause 4.2.6 refer to average power levels.

A simple measurement using the Video Average detector of the spectrum analyser is permitted. The measured values shall be recorded and compared with the limits in clause 4.2.6.

#### 5.3.7.2.2 Radiated measurement

The test set up as described in annex B shall be used with a spectrum analyser of sufficient accuracy attached to the test antenna (see clause 5.2).

The test procedure is as described under clause 5.3.7.2.1.

## Annex A (normative): HS Requirements and conformance Test specifications Table (HS-RTT)

The HS Requirements and conformance Test specifications Table (HS-RTT) in table A.1 serves a number of purposes, as follows:

- it provides a statement of all the requirements in words and by cross reference to (a) specific clause(s) in the present document or to (a) specific clause(s) in (a) specific referenced document(s);
- it provides a statement of all the test procedures corresponding to those requirements by cross reference to (a) specific clause(s) in the present document or to (a) specific clause(s) in (a) specific referenced document(s);
- it qualifies each requirement to be either:
  - Unconditional: meaning that the requirement applies in all circumstances; or
  - Conditional: meaning that the requirement is dependent on the manufacturer having chosen to support optional functionality defined within the schedule.
- in the case of Conditional requirements, it associates the requirement with the particular optional service or functionality;
- it qualifies each test procedure to be either:
  - Essential: meaning that it is included with the Essential Radio Test Suite and therefore the requirement shall be demonstrated to be met in accordance with the referenced procedures;
  - Other: meaning that the test procedure is illustrative but other means of demonstrating compliance with the requirement are permitted.

**Table A.1: HS Requirements and conformance Test specifications Table (HS-RTT)**

<b>Harmonized Standard EN 302 625</b>						
The following requirements and test specifications are relevant to the presumption of conformity under the article 3.2 of the R&TTE Directive						
<b>Requirement</b>			<b>Requirement Conditionality</b>		<b>Test Specification</b>	
<b>No</b>	<b>Description</b>	<b>Reference: Clause No</b>	<b>U/C</b>	<b>Condition</b>	<b>E/O</b>	<b>Reference: Clause No</b>
1	Carrier Frequencies	4.2.1	U		E	5.3.2
2	Nominal channel bandwidth and occupied bandwidth	4.2.2	U		E	5.3.3
3	RF output power, and Power Spectral Density (PSD)	4.2.3	U		E	5.3.4
4	Transmitter unwanted emissions outside the BBDR frequency bands	4.2.4	U		E	5.3.5
5	Transmitter unwanted emissions within the BBDR frequency bands	4.2.5	U		E	5.3.6
6	Receiver spurious emissions	4.2.6	U		E	5.3.7

**Key to columns:****Requirement:**

**No** A unique identifier for one row of the table which may be used to identify a requirement or its test specification.

**Description** A textual reference to the requirement.

**Clause Number** Identification of clause(s) defining the requirement in the present document unless another document is referenced explicitly.

**Requirement Conditionality:**

**U/C** Indicates whether the requirement is to be *unconditionally* applicable (U) or is *conditional* upon the manufacturers claimed functionality of the equipment (C).

**Condition** Explains the conditions when the requirement shall or shall not be applicable for a technical requirement which is classified "conditional".

**Test Specification:**

**E/O** Indicates whether the test specification forms part of the Essential Radio Test Suite (E) or whether it is one of the Other Test Suite (O).

**NOTE:** All tests whether "E" or "O" are relevant to the requirements. Rows designated "E" collectively make up the Essential Radio Test Suite; those designated "O" make up the Other Test Suite; for those designated "X" there is no test specified corresponding to the requirement. The completion of all tests classified "E" as specified with satisfactory outcomes is a necessary condition for a presumption of conformity. Compliance with requirements associated with tests classified "O" or "X" is a necessary condition for presumption of conformity, although conformance with the requirement may be claimed by an equivalent test or by manufacturer's assertion supported by appropriate entries in the technical construction file.

**Clause Number** Identification of clause(s) defining the test specification in the present document unless another document is referenced explicitly. Where no test is specified (that is, where the previous field is "X") this field remains blank.

## Annex B (normative): Test sites and arrangements for radiated measurements

### B.1 Test sites

#### B.1.1 Open air test sites

The term "open air" should be understood from an electromagnetic point of view. Such a test site may be really in open air or alternatively with walls and ceiling transparent to the radio waves at the frequencies considered.

An open air test site may be used to perform the measurements using the radiated measurement methods described in clause 5. Absolute or relative measurements may be performed on transmitters or on receivers; absolute measurements of field strength require a calibration of the test site. Above 1 GHz, measurements should be done in anechoic conditions. This may be met by semi anechoic sites provided reflections are avoided.

For measurements at frequencies below 1 GHz, a measurement distance appropriate to the frequency shall be used. For frequencies above 1 GHz, any suitable measuring distance may be used. The equipment size (excluding the antenna) shall be less than 20 % of the measuring distance. The height of the equipment or of the substitution antenna shall be 1,5 m; the height of the test antenna (transmit or receive) shall vary between 1 m and 4 m.

Sufficient precautions shall be taken to ensure that reflections from extraneous objects adjacent to the site do not degrade the measurement results, in particular:

- no extraneous conducting objects having any dimension in excess of a quarter wavelength of the highest frequency tested shall be in the immediate vicinity of the site according to CISPR 16 [2];
- all cables shall be as short as possible; as much of the cables as possible shall be on the ground plane or preferably below; and the low impedance cables shall be screened.

The general measurement arrangement is shown in figure B.1.

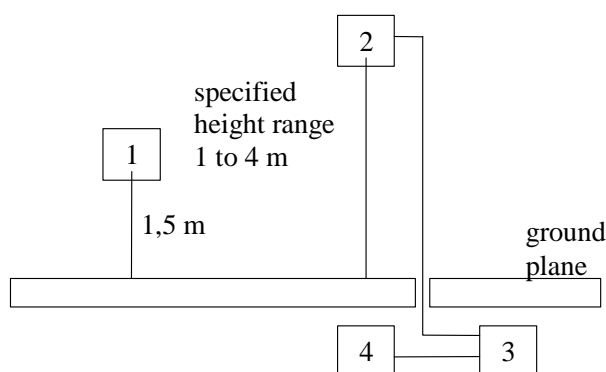

- NOTE:
- 1: Equipment under test.
  - 2: Test antenna.
  - 3: High pass filter (as required).
  - 4: Spectrum analyser or measuring receiver.

**Figure B.1: Measuring arrangement**

## B.1.2 Anechoic chamber

### B.1.2.1 General

An anechoic chamber is a well shielded chamber covered inside with radio frequency absorbing material and simulating a free space environment. It is an alternative site on which to perform the measurements using the radiated measurement methods described in clause C.2. Absolute or relative measurements may be performed on transmitters or on receivers. Absolute measurements of field strength require a calibration of the anechoic chamber. The test antenna, equipment under test and substitution antenna are used in a way similar to that at the open air test site, but are all located at the same fixed height above the floor.

### B.1.2.2 Description

An anechoic chamber should meet the requirements for shielding loss and wall return loss as shown in figure B.2. Figure B.3 shows an example of the construction of an anechoic chamber having a base area of 5 m by 10 m and a height of 5 m. The ceiling and walls are coated with pyramidically formed absorbers approximately 1 m high. The base is covered with special absorbers which form the floor. The available internal dimensions of the chamber are 3 m x 8 m x 3 m, so that a maximum measuring distance of 5 m in the middle axis of this chamber is available. The floor absorbers reject floor reflections so that the antenna height need not be changed. Anechoic chambers of other dimensions may be used.

### B.1.2.3 Influence of parasitic reflections

For free-space propagation in the far field, the relationship of the field strength  $E$  and the distance  $R$  is given by  $E = E_0 \times (R_0/R)$ , where  $E_0$  is the reference field strength and  $R_0$  is the reference distance. This relationship allows relative measurements to be made as all constants are eliminated within the ratio and neither cable attenuation nor antenna mismatch or antenna dimensions are of importance.

If the logarithm of the foregoing equation is used, the deviation from the ideal curve may be easily seen because the ideal correlation of field strength and distance appears as a straight line. The deviations occurring in practice are then clearly visible. This indirect method shows quickly and easily any disturbances due to reflections and is far less difficult than the direct measurement of reflection attenuation.

With an anechoic chamber of the dimensions given above at low frequencies below 100 MHz there are no far field conditions, but the wall reflections are stronger, so that careful calibration is necessary. In the medium frequency range from 100 MHz to 1 GHz the dependence of the field strength to the distance meets the expectations very well. Above 1 GHz, because more reflections will occur, the dependence of the field strength to the distance will not correlate so closely.

### B.1.2.4 Calibration and mode of use

The calibration and mode of use is the same as for an open air test site, the only difference being that the test antenna does not need to be raised and lowered whilst searching for a maximum, which simplifies the method of measurement.

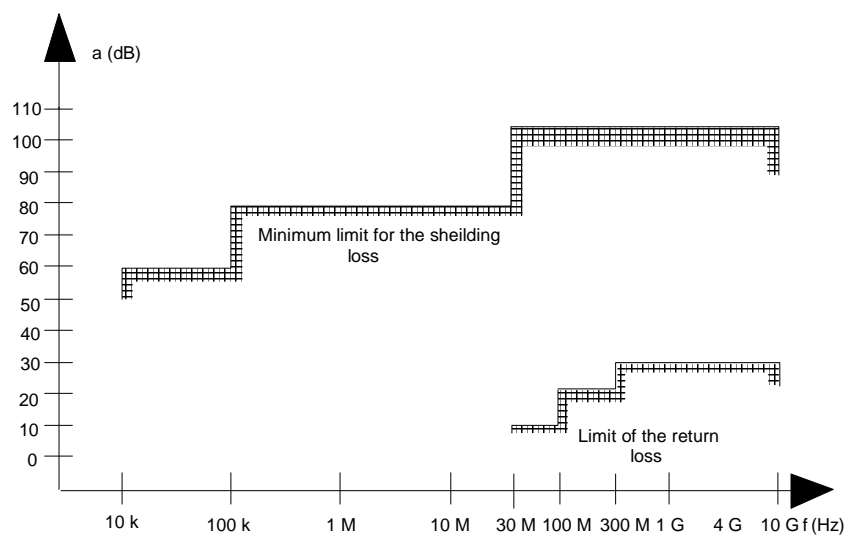

**Figure B.2: Specification for shielding and reflections**



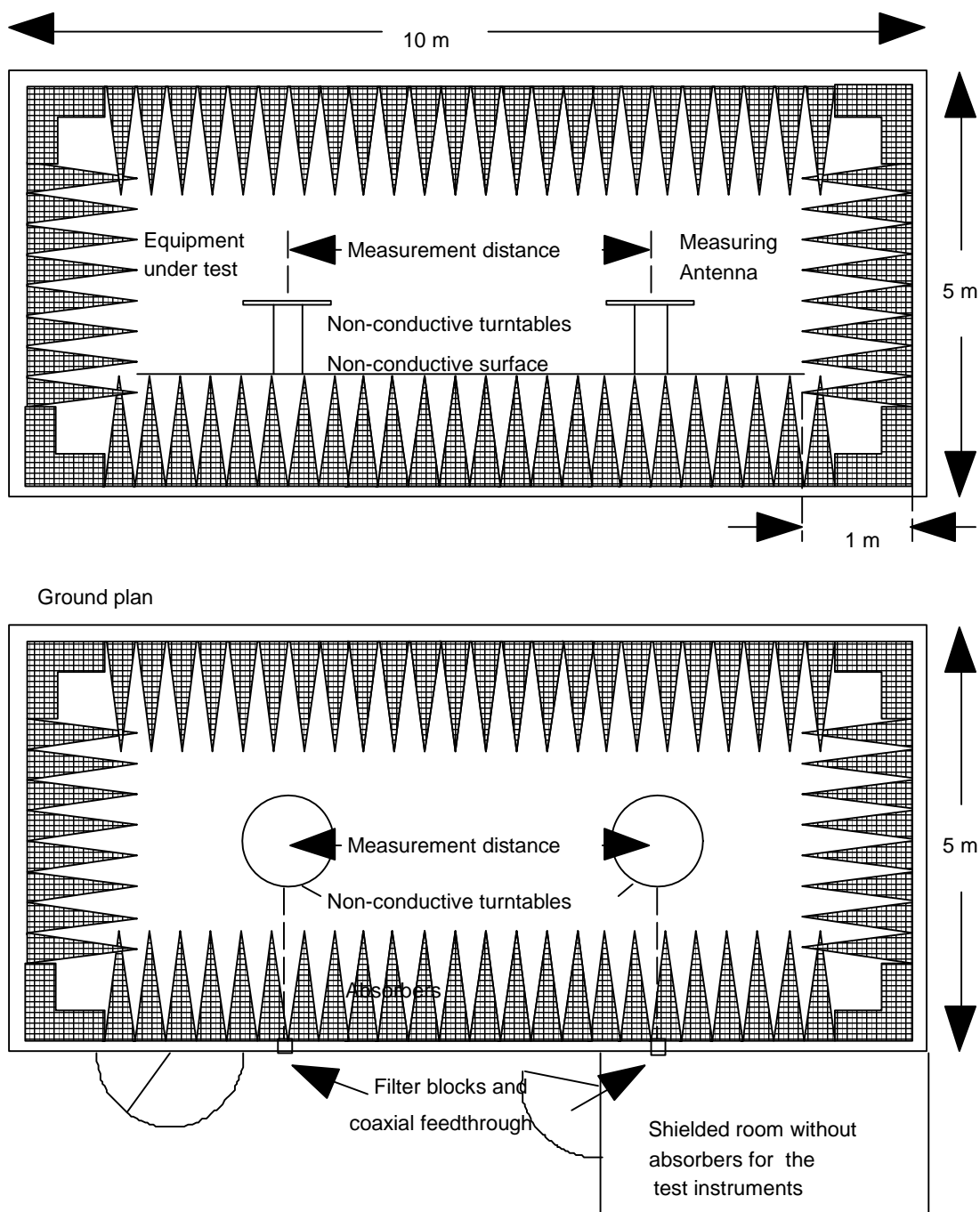

Figure B.3: Anechoic shielded chamber for simulated free space measurements

## B.2 Test antenna

When the test site is used for radiation measurements the test antenna shall be used to detect the field from both the test sample and the substitution antenna. When the test site is used for the measurement of receiver characteristics the antenna shall be used as a transmitting antenna. This antenna shall be mounted on a support capable of allowing the antenna to be used in either horizontal or vertical polarization and for the height of its centre above the ground to be varied over the specified range. Preferably test antennas with pronounced directivity should be used. The size of the test antenna along the measurement axis shall not exceed 20 % of the measuring distance.

---

## B.3 Substitution antenna

The substitution antenna shall be used to replace the UUT in substitution measurements. For measurements below 1 GHz the substitution antenna shall be a half wavelength dipole resonant at the frequency under consideration, or a shortened dipole, calibrated to the half wavelength dipole. For measurements between 1 GHz and 4 GHz either a half wavelength dipole or a horn radiator may be used. For measurements above 4 GHz a horn radiator shall be used. The centre of this antenna shall coincide with the reference point of the test sample it has replaced. This reference point shall be the volume centre of the sample when its antenna is mounted inside the cabinet, or the point where an outside antenna is connected to the cabinet.

The distance between the lower extremity of the dipole and the ground shall be at least 30 cm.

NOTE: The gain of a horn antenna is generally expressed relative to an isotropic radiator.

## Annex C (normative): General description of measurement

This annex gives the general methods of measurements for RF signals using the test sites and arrangements described in annex B.

### C.1 Conducted measurements

Conducted measurements may be applied to equipment provided with an antenna connector e.g. by means of a spectrum analyser.

### C.2 Radiated measurements

Radiated measurements shall be performed with the aid of a test antenna and measurement instruments as described in annex B. The test antenna and measurement instrument shall be calibrated according to the procedure defined in this annex. The equipment to be measured and the test antenna shall be oriented to obtain the maximum emitted power level. This position shall be recorded in the measurement report. The frequency range shall be measured in this position.

Radiated measurements should be performed in an anechoic chamber. For other test sites corrections may be needed (see annex B). The following test procedure applies:

- a) a test site which fulfils the requirements of the specified frequency range of this measurement shall be used. The test antenna shall be oriented initially for vertical polarization unless otherwise stated and the transmitter under test shall be placed on the support in its standard position (clause B.1.1) and switched on;
- b) for average power measurements a non-selective voltmeter or wideband spectrum analyser shall be used. For other measurements a spectrum analyser or selective voltmeter shall be used and tuned to the measurement frequency.

In either case a) or b), the test antenna shall be raised or lowered, if necessary, through the specified height range until the maximum signal level is detected on the spectrum analyser or selective voltmeter.

The test antenna need not be raised or lowered if the measurement is carried out on a test site according to clause B.1.2.

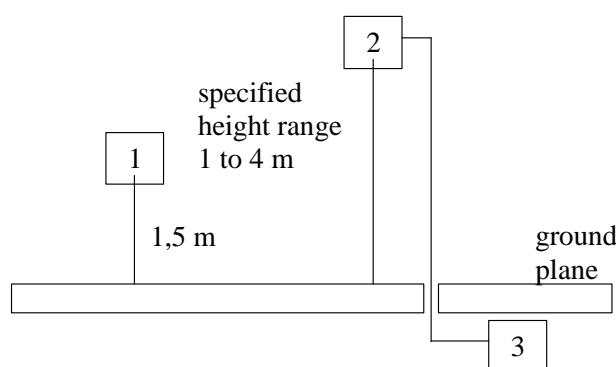

- NOTE: 1: Equipment under test.  
2: Test antenna.  
3: Spectrum analyser or measuring receiver.

**Figure C.1: Measurement arrangement 1**

- The transmitter shall be rotated through 360° about a vertical axis until a higher maximum signal is received.
- The test antenna shall be raised or lowered again, if necessary, through the specified height range until a maximum is obtained. This level shall be recorded.

NOTE: This maximum may be a lower value than the value obtainable at heights outside the specified limits.

The test antenna need not be raised or lowered if the measurement is carried out on a test site according to clause B.1.2. This measurement shall be repeated for horizontal polarization. The result of the measurement is the higher power obtained from the two measurements with the indication of the corresponding polarization.

## C.3 Substitution measurement

The actual signal generated by the measured equipment may be determined by means of a substitution measurement in which a known signal source replaces the device to be measured, see figure C.2. This method of measurement should be used in an anechoic chamber. For other test sites corrections may be needed, see annex B.

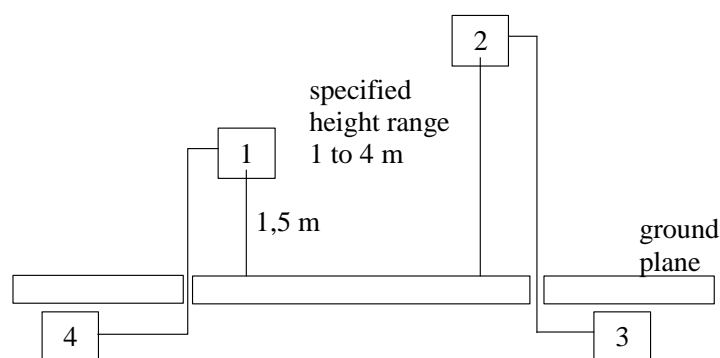

- NOTE: 1: Substitution antenna.  
 2: Test antenna.  
 3: Spectrum analyser or selective voltmeter.  
 4: Signal generator.

**Figure C.2: Measurement arrangement 2**

Using measurement arrangement 2, figure C.2, the substitution antenna shall replace the transmitter antenna in the same position and in vertical polarization. The frequency of the signal generator shall be adjusted to the measurement frequency. The test antenna shall be raised or lowered, if necessary, to ensure that the maximum signal is still received. The input signal to the substitution antenna shall be adjusted in level until an equal or a known related level to that detected from the transmitter is obtained in the test receiver.

The test antenna need not be raised or lowered if the measurement is carried out on a test site according to clause B.1.2.

The radiated power is equal to the power supplied by the signal generator, increased by the known relationship if necessary and after corrections due to the gain of the substitution antenna and the cable loss between the signal generator and the substitution antenna.

This measurement shall be repeated with horizontal polarization. The result of the measurement is the higher power obtained from the two measurements with the indication of the corresponding polarization.

---

## Annex D (informative): The EN title in the official languages

The enlargement of the European Union (EU) resulted in a requirement from the EU for a larger number of languages for the translation of the titles of Harmonized Standards and mandated ENs that are to be listed in the Official Journal to support the implementation of this legislation.

For this reason the title translation concerning the present document can be consulted via the [e-approval](#) application.

---

## Annex E (informative): Bibliography

ETSI TR 102 070-2 (V1.1.1): "Electromagnetic compatibility and Radio spectrum Matters (ERM); Guide to the application of harmonized standards to multi-radio and combined radio and non-radio equipment; Part 2: Effective use of the radio frequency spectrum".

ETSI TR 102 273 (2001) (all parts): "Electromagnetic compatibility and Radio spectrum Matters (ERM); Improvement of radiated methods of measurement (using test sites) and evaluation of the corresponding measurement uncertainties".

ETSI TR 102 485: "Electromagnetic compatibility and Radio spectrum Matters (ERM); Technical characteristics for Broadband Disaster Relief applications (BB-DR) for emergency services in disaster situations; System Reference Document".

ECC Report 102: "Public Protection and Disaster Relief Spectrum Requirements".

ANSI C63.5 (2004): "American National Standard for Electromagnetic Compatibility-Radiated Emission Measurements in Electromagnetic Interference (EMI) Control-Calibration of Antennas (9 kHz to 40 GHz)".

Directive 2004/108/EC of The European Parliament and of The Council of 15 December 2004 on the approximation of the laws of the Member States relating to electromagnetic compatibility and repealing Directive 89/336/EEC.

Directive 2006/95/EC of The European Parliament and of The Council of 12 December 2006 on the harmonization of the laws of Member States relating to electrical equipment designed for use within certain voltage limits.

---

## History

<b>Document history</b>		
V1.1.1	September 2008	Public Enquiry PE 20090111: 2008-09-13 to 2009-01-12
V1.1.1	May 2009	Vote V 20090725: 2009-05-26 to 2009-07-27