

Draft **ETSI EN 302 623** V0.3.2 (2008-05)

---

*Harmonized European Standard (Telecommunications series)*

**Broadband Wireless Access Systems (BWA) in the  
3 400 MHz to 3 800 MHz frequency band;  
Mobile Terminal Stations;  
Harmonized EN covering the essential requirements  
of article 3.2 of the R&TTE Directive**

---



---

**Reference**DEN/BRAN-0060002

---

---

**Keywords**access, broadband, BWA, mobile, terminal

---

**ETSI**

---

650 Route des Lucioles  
F-06921 Sophia Antipolis Cedex - FRANCE

---

Tel.: +33 4 92 94 42 00 Fax: +33 4 93 65 47 16

Siret N° 348 623 562 00017 - NAF 742 C  
Association à but non lucratif enregistrée à la  
Sous-Préfecture de Grasse (06) N° 7803/88

---

**Important notice**

---

Individual copies of the present document can be downloaded from:

<http://www.etsi.org>

The present document may be made available in more than one electronic version or in print. In any case of existing or perceived difference in contents between such versions, the reference version is the Portable Document Format (PDF). In case of dispute, the reference shall be the printing on ETSI printers of the PDF version kept on a specific network drive within ETSI Secretariat.

Users of the present document should be aware that the document may be subject to revision or change of status. Information on the current status of this and other ETSI documents is available at

<http://portal.etsi.org/tb/status/status.asp>

If you find errors in the present document, please send your comment to one of the following services:

[http://portal.etsi.org/chaicor/ETSI\\_support.asp](http://portal.etsi.org/chaicor/ETSI_support.asp)

---

**Copyright Notification**

---

No part may be reproduced except as authorized by written permission.  
The copyright and the foregoing restriction extend to reproduction in all media.

© European Telecommunications Standards Institute 2008.  
All rights reserved.

**DECT™**, **PLUGTESTS™**, **UMTS™**, **TIPHON™**, the TIPHON logo and the ETSI logo are Trade Marks of ETSI registered for the benefit of its Members.

**3GPP™** is a Trade Mark of ETSI registered for the benefit of its Members and of the 3GPP Organizational Partners.

# Contents

Intellectual Property Rights .....	5
Foreword.....	5
Introduction .....	5
1 Scope .....	6
2 References .....	6
2.1 Normative references .....	6
2.2 Informative references.....	7
3 Definitions, symbols and abbreviations .....	7
3.1 Definitions .....	7
3.2 Symbols.....	7
3.3 Abbreviations .....	7
4 Essential requirements specification .....	8
4.1 Environmental profile.....	8
4.2 Conformance requirements .....	8
4.2.1 Introduction.....	8
4.2.2 Transmitter output power.....	8
4.2.2.1 Definition .....	8
4.2.2.2 Limits .....	8
4.2.2.3 Output Power tolerance.....	8
4.2.3 Transmitter spectrum emission mask.....	9
4.2.3.1 Definition .....	9
4.2.3.2 Limits .....	9
4.2.3.2.1 Spectrum Emission Mask for 5 MHz Bandwidth .....	9
4.2.3.2.2 Spectrum Emission Mask for 7 MHz Bandwidth .....	9
4.2.3.2.3 Spectrum Emission Mask for 10 MHz Bandwidth .....	10
4.2.4 Transmitter Adjacent Channel Leakage power Ratio (ACLR) .....	11
4.2.4.1 Definition .....	11
4.2.4.2 Limits .....	11
4.2.5 Transmitter spurious emissions.....	11
4.2.5.1 Definition .....	11
4.2.5.2 Limits .....	12
4.2.6 Transmitter power control .....	12
4.2.6.1 Definition .....	12
4.2.6.2 Limits .....	12
4.2.7 Receiver spurious emissions .....	12
4.2.7.1 Definition .....	12
4.2.7.2 Limits .....	12
4.2.8 Receiver adjacent and alternate channel rejection .....	12
4.2.8.1 Definition .....	12
4.2.8.2 Limits .....	13
4.2.9 Control and monitoring functions .....	13
4.2.9.1 Definition .....	13
4.2.9.2 Limits .....	13
4.2.9.3 Conformance.....	13
5 Testing for compliance with technical requirements.....	13
5.1 Environmental conditions for testing .....	13
5.2 Product information.....	14
5.3 Interpretation of the measurement results .....	14
5.4 Essential radio test suites.....	15
5.4.1 Transmitter spectrum emission mask.....	15
5.4.1.1 Method of test for mobile TS spectral emission mask .....	15
5.4.1.1.1 Initial conditions.....	15
5.4.1.1.2 Procedure.....	15

5.4.2	Transmitter adjacent channel leakage power ratio (ACLR).....	16
5.4.2.1	Method of test for mobile TS ACLR.....	16
5.4.2.1.1	Initial conditions .....	16
5.4.2.1.2	Procedure.....	16
5.4.3	Transmitter spurious emissions.....	17
5.4.3.1	Method of test for mobile TS transmitter spurious emission .....	17
5.4.3.1.1	Initial conditions .....	17
5.4.3.1.2	Procedure.....	17
5.4.4	Transmitter output power and transmit power control.....	17
5.4.4.1	Method of test .....	18
5.4.4.1.1	Initial conditions .....	18
5.4.4.1.2	Procedure.....	18
5.4.5	Receiver spurious emissions .....	18
5.4.5.1	Method of test .....	18
5.4.5.1.1	Initial conditions .....	19
5.4.5.1.2	Procedure.....	19
5.4.6	Receiver adjacent and alternate channel rejection .....	19
5.4.6.1	Method of test .....	19
5.4.6.1.1	Procedure.....	19
5.4.7	Control and monitoring functions.....	20
5.4.7.1	Method of test .....	20
<b>Annex A (normative):</b>	<b>HS Requirements and conformance Test specifications Table (HS-RTT).....</b>	<b>21</b>
<b>Annex B (informative):</b>	<b>The EN title in the official languages .....</b>	<b>23</b>
<b>Annex C (informative):</b>	<b>Bibliography.....</b>	<b>24</b>
History .....		25

---

## Intellectual Property Rights

IPRs essential or potentially essential to the present document may have been declared to ETSI. The information pertaining to these essential IPRs, if any, is publicly available for **ETSI members and non-members**, and can be found in ETSI SR 000 314: "*Intellectual Property Rights (IPRs); Essential, or potentially Essential, IPRs notified to ETSI in respect of ETSI standards*", which is available from the ETSI Secretariat. Latest updates are available on the ETSI Web server (<http://webapp.etsi.org/IPR/home.asp>).

Pursuant to the ETSI IPR Policy, no investigation, including IPR searches, has been carried out by ETSI. No guarantee can be given as to the existence of other IPRs not referenced in ETSI SR 000 314 (or the updates on the ETSI Web server) which are, or may be, or may become, essential to the present document.

---

## Foreword

This Harmonized European Standard (Telecommunications series) has been produced by ETSI Technical Committee Broadband Radio Access Networks (BRAN), and is now submitted for the Public Enquiry phase of the ETSI standards Two-step Approval Procedure.

The present document has been produced by ETSI in response to a mandate from the European Commission issued under Council Directive 98/34/EC [4] (as amended) laying down a procedure for the provision of information in the field of technical standards and regulations.

The present document is intended to become a Harmonized Standard, the reference of which will be published in the Official Journal of the European Communities referencing the Directive 1999/5/EC [5] of the European Parliament and of the Council of 9 March 1999 on radio equipment and telecommunications terminal equipment and the mutual recognition of their conformity ("the R&TTE Directive").

Technical specifications relevant to Directive 1999/5/EC are given in annex A.

<b>Proposed national transposition dates</b>	
Date of latest announcement of this EN (doa):	3 months after ETSI publication
Date of latest publication of new National Standard or endorsement of this EN (dop/e):	6 months after doa
Date of withdrawal of any conflicting National Standard (dow):	18 months after doa

---

## Introduction

The present document is part of a set of standards developed by ETSI and is designed to fit in a modular structure to cover all radio and telecommunications terminal equipment within the scope of the R&TTE Directive. The modular structure is shown in EG 201 399 [6].

---

# 1 Scope

The present document is applicable to FDD and TDD Mobile Terminal Stations (TS) of Broadband Wireless Access Systems (BWA) in the Frequency Band 3 400 MHz to 3 800 MHz.

The document is equally applicable to systems utilizing integral or non integral antennas.

The present document is intended to cover the provisions of Directive 1999/5/EC [5] (R&TTE Directive) Article 3.2, which states that: "... radio equipment shall be so constructed that it effectively uses the spectrum allocated to terrestrial/space radio communications and orbital resources so as to avoid harmful interference".

In addition to the present document, other ENs that specify technical requirements in respect of essential requirements under other parts of Article 3 of the R&TTE Directive may apply to equipment within the scope of the present document.

NOTE: A list of such ENs is included on the web site <http://www.newapproach.org>.

---

# 2 References

References are either specific (identified by date of publication and/or edition number or version number) or non-specific.

- For a specific reference, subsequent revisions do not apply.
- Non-specific reference may be made only to a complete document or a part thereof and only in the following cases:
  - if it is accepted that it will be possible to use all future changes of the referenced document for the purposes of the referring document;
  - for informative references.

Referenced documents which are not found to be publicly available in the expected location might be found at <http://docbox.etsi.org/Reference>.

For online referenced documents, information sufficient to identify and locate the source shall be provided. Preferably, the primary source of the referenced document should be cited, in order to ensure traceability. Furthermore, the reference should, as far as possible, remain valid for the expected life of the document. The reference shall include the method of access to the referenced document and the full network address, with the same punctuation and use of upper case and lower case letters.

NOTE: While any hyperlinks included in this clause were valid at the time of publication ETSI cannot guarantee their long term validity.

## 2.1 Normative references

The following referenced documents are indispensable for the application of the present document. For dated references, only the edition cited applies. For non-specific references, the latest edition of the referenced document (including any amendments) applies.

- [1] ETSI EN 300 019 (all parts): "Environmental Engineering (EE); Environmental conditions and environmental tests for telecommunications equipment".
- [2] ETSI TR 100 028 (all parts) (V1.4.1): "Electromagnetic compatibility and Radio spectrum Matters (ERM); Uncertainties in the measurement of mobile radio equipment characteristics".
- [3] ETSI TR 102 215 (V1.3.1): "Electromagnetic compatibility and Radio spectrum Matters (ERM); Recommended approach, and possible limits for measurement uncertainty for the measurement of radiated electromagnetic fields above 1 GHz".

## 2.2 Informative references

The following referenced documents are not essential to the use of the present document but they assist the user with regard to a particular subject area. For non-specific references, the latest version of the referenced document (including any amendments) applies.

- [4] Directive 98/34/EC of the European Parliament and of the Council of 22 June 1998 laying down a procedure for the provision of information in the field of technical standards and regulations.
- [5] Directive 1999/5/EC of the European Parliament and of the Council of 9 March 1999 on radio equipment and telecommunications terminal equipment and the mutual recognition of their conformity (R&TTE Directive).
- [6] ETSI EG 201 399 (V2.1.1): "Electromagnetic compatibility and Radio spectrum Matters (ERM); A guide to the production of candidate Harmonized Standards for application under the R&TTE Directive".

---

## 3 Definitions, symbols and abbreviations

### 3.1 Definitions

For the purposes of the present document, the following terms and definitions apply:

**Automatic Transmit Power Control (ATPC):** function implemented to offer a dynamic power control

**environmental profile:** declared range of environmental conditions under which equipment within the scope of the present document is required to be compliant

**maximum output power:** maximum mean output power available at the antenna connector; for equipment implementing dynamic change of modulation format, it is intended as the maximum mean output power associated to the modulation format delivering the highest power

**maximum power density:** maximum mean output power density, defined as dBm/MHz

**maximum radiated power density:** maximum mean radiated output power (EIRP) density, defined as dBm/MHz

### 3.2 Symbols

For the purposes of the present document, the following symbols apply:

A <sub>BS</sub>	Base Station Interface A
A <sub>TS</sub>	Terminal Station Interface A
A <sub>UUT</sub>	Unit Under Test Interface A
dB	deciBel
dBc	deciBel relative to carrier
dBm	deciBel relative to 1 mW
f <sub>c</sub>	center frequency
GHz	GigaHertz
kHz	kiloHertz
MHz	MegaHertz

### 3.3 Abbreviations

For the purposes of the present document, the following abbreviations apply:

ACLR	Adjacent Channel Leakage power Ratio
ATPC	Automatic Transmit Power Control
BER	Bit Error Rate
BWA	Broadband Wireless Access

FDD	Frequency Division Duplex
PER	Packet Error Rate
TDD	Time Division Duplex
TPC	Transmit Power Control
TS	Terminal Station
UUT	Unit Under Test

## 4 Essential requirements specification

### 4.1 Environmental profile

The technical requirements of the present document apply under the environmental profile for operation of the equipment, which shall be declared by the supplier. The equipment shall comply with all the technical requirements of the present document at all times when operating within the boundary limits of the declared operational environmental profile.

### 4.2 Conformance requirements

#### 4.2.1 Introduction

To meet the essential requirement under article 3.2 of the R&TTE Directive five essential parameters have been identified. Table 1 provides a cross reference between these five essential parameters and the corresponding seven technical requirements for equipment within the scope of the present document. To fulfil an essential parameter the compliance with all the corresponding technical requirements in table 1 must be verified.

**Table 1: Cross references**

<b>Essential parameter</b>	<b>Corresponding technical requirements</b>
Spectrum emissions mask	4.2.3 Transmitter Spectrum emissions mask
	4.2.4 Transmitter adjacent channel leakage power ratio
Conducted spurious emissions from the transmitter antenna connector	4.2.5 Transmitter spurious emissions
Output power	4.2.2 Transmitter output power
	4.2.6 Transmitter power control
Conducted spurious emissions from the receiver antenna connector	4.2.7 Receiver spurious emissions
Impact of interference on receiver performance	4.2.8 Receiver adjacent and alternate rejection
Control and monitoring functions	4.2.9 Control and monitoring functions

#### 4.2.2 Transmitter output power

##### 4.2.2.1 Definition

The maximum power of the transmitter has to be defined in terms of maximum radiated power density. The terms maximum output power, maximum power density and maximum radiated power density are defined in clause 3.1.

##### 4.2.2.2 Limits

The maximum radiated power density is 25 dBm/MHz.

##### 4.2.2.3 Output Power tolerance

The maximum output power shall be declared by the supplier. The error of the maximum output power shall be within a tolerance of  $\pm 2$  dB under normal conditions. In any case the limit for the maximum radiated power density shall not be exceeded.



## 4.2.3 Transmitter spectrum emission mask

### 4.2.3.1 Definition

Spectrum emission mask defines an out of band emission requirement for the transmitter. These out of band emissions are unwanted emissions outside the channel bandwidth resulting from the modulation process and non-linearity in the transmitter but excluding spurious emissions.

### 4.2.3.2 Limits

#### 4.2.3.2.1 Spectrum Emission Mask for 5 MHz Bandwidth

The spectrum emission mask of the TS applies to frequency offsets between 2,5 MHz and 12,5 MHz on both sides of the TS center carrier frequency. The out-of-channel emission is specified as power level measured over the specified measurement bandwidth but relative to the total mean power of the TS carrier measured in the 5 MHz band.

The TS emission shall not exceed the levels specified in table 2.

**Table 2: Spectrum emission mask requirement (5 MHz option)**

Frequency offset $\Delta f$	Minimum requirement	Measurement bandwidth
2,5 MHz to 3,5 MHz	$\left\{ -33,5 - 15 \times \left( \frac{\Delta f}{\text{MHz}} - 2,5 \right) \right\} \text{dBc}$	30 kHz
3,5 MHz to 7,5 MHz	$\left\{ -33,5 - 1 \times \left( \frac{\Delta f}{\text{MHz}} - 3,5 \right) \right\} \text{dBc}$	1 MHz
7,5 MHz to 8,5 MHz	$\left\{ -37,5 - 10 \times \left( \frac{\Delta f}{\text{MHz}} - 7,5 \right) \right\} \text{dBc}$	1 MHz
8,5 MHz to 12,5 MHz	-47,5 dBc	1 MHz
NOTE 1: $\Delta f$ is the separation between the carrier frequency and the centre of the measuring filter. NOTE 2: The first measurement position with a 30 kHz filter is at $\Delta f$ equals to 2,515 MHz; the last is at $\Delta f$ equals to 3,485 MHz. NOTE 3: The first measurement position with a 1 MHz filter is at $\Delta f$ equals to 4 MHz; the last is at $\Delta f$ equals to 12 MHz. As a general rule, the resolution bandwidth of the measuring equipment should be equal to the measurement bandwidth. To improve measurement accuracy, sensitivity and efficiency, the resolution bandwidth can be different from the measurement bandwidth. When the resolution bandwidth is smaller than the measurement bandwidth, the result should be integrated over the measurement bandwidth in order to obtain the equivalent noise bandwidth of the measurement bandwidth. NOTE 4: Note that equivalent PSD type mask can be derived by applying $10 \cdot \log((5 \text{ MHz})/(30 \text{ kHz})) = 22,2 \text{ dB}$ and $10 \cdot \log((5 \text{ MHz})/(1 \text{ MHz})) = 7 \text{ dB}$ scaling factor for 30 kHz and 1 MHz measurement bandwidth respectively.		

#### 4.2.3.2.2 Spectrum Emission Mask for 7 MHz Bandwidth

The spectrum emission mask of the TS applies to frequency offsets between 3,5 MHz and 17,5 MHz on both sides of the TS center carrier frequency. The out-of-channel emission is specified as power level measured over the specified measurement bandwidth but relative to the total mean power of the TS carrier measured in the 7 MHz band.

The TS emission shall not exceed the levels specified in table 3.

Table 3: Spectrum emission mask requirement (7 MHz option)

Frequency offset $\Delta f$	Minimum requirement	Measurement bandwidth
3,5 MHz to 4,75 MHz	$\left\{ -33,5 - 13,5 \times \left( \frac{\Delta f}{\text{MHz}} - 3,5 \right) \right\} \text{dBc}$	30 kHz
4,75 MHz to 10,5 MHz	$\left\{ -35,0 - 0,7 \times \left( \frac{\Delta f}{\text{MHz}} - 4,75 \right) \right\} \text{dBc}$	1 MHz
10,5 MHz to 11,9 MHz	$\left\{ -39,0 - 7 \times \left( \frac{\Delta f}{\text{MHz}} - 10,5 \right) \right\} \text{dBc}$	1 MHz
11,9 MHz to 17,5 MHz	-49,0 dBc	1 MHz
<p>NOTE 1: <math>\Delta f</math> is the separation between the carrier frequency and the centre of the measuring filter.</p> <p>NOTE 2: The first measurement position with a 30 kHz filter is at <math>\Delta f</math> equals to 3,515 MHz; the last is at <math>\Delta f</math> equals to 4,735 MHz.</p> <p>NOTE 3: The first measurement position with a 1 MHz filter is at <math>\Delta f</math> equals to 5,25 MHz; the last is at <math>\Delta f</math> equals to 17 MHz. As a general rule, the resolution bandwidth of the measuring equipment should be equal to the measurement bandwidth. To improve measurement accuracy, sensitivity and efficiency, the resolution bandwidth can be different from the measurement bandwidth. When the resolution bandwidth is smaller than the measurement bandwidth, the result should be integrated over the measurement bandwidth in order to obtain the equivalent noise bandwidth of the measurement bandwidth.</p> <p>NOTE 4: Note that equivalent PSD type mask can be derived by applying <math>10 \cdot \log((5 \text{ MHz})/(30 \text{ kHz})) = 23,7 \text{ dB}</math> and <math>10 \cdot \log((5 \text{ MHz})/(1 \text{ MHz})) = 8,5 \text{ dB}</math> scaling factor for 30 kHz and 1 MHz measurement bandwidth respectively.</p>		

#### 4.2.3.2.3 Spectrum Emission Mask for 10 MHz Bandwidth

The spectrum emission mask of the TS applies to frequency offsets between 5 MHz and 25 MHz on both sides of the TS center carrier frequency. The out-of-channel emission is specified as a power level relative to the total mean power of the TS carrier measured in the 10 MHz band.

The TS emission shall not exceed the levels specified in table 4.

**Table 4: Spectrum emission mask requirement (10 MHz option)**

Frequency offset $\Delta f$	Minimum requirement	Measurement bandwidth
5,0 MHz to 7,0 MHz	$\left\{ -33,5 - 9 \times \left( \frac{\Delta f}{\text{MHz}} - 5,0 \right) \right\} \text{dBc}$	30 kHz
7,0 MHz to 15,0 MHz	$\left\{ -36,5 - 0,5 \times \left( \frac{\Delta f}{\text{MHz}} - 7,0 \right) \right\} \text{dBc}$	1 MHz
15,0 MHz to 17,0 MHz	$\left\{ -40,5 - 5 \times \left( \frac{\Delta f}{\text{MHz}} - 15,0 \right) \right\} \text{dBc}$	1 MHz
17,0 MHz to 25,0 MHz	-50,5 dBc	1 MHz
<p>NOTE 1: <math>\Delta f</math> is the separation between the carrier frequency and the centre of the measuring filter.</p> <p>NOTE 2: The first measurement position with a 30 kHz filter is at <math>\Delta f</math> equals to 10,015 MHz; the last is at <math>\Delta f</math> equals to 6,985 MHz.</p> <p>NOTE 3: The first measurement position with a 1 MHz filter is at <math>\Delta f</math> equals to 7,5 MHz; the last is at <math>\Delta f</math> equals to 24,5 MHz. As a general rule, the resolution bandwidth of the measuring equipment should be equal to the measurement bandwidth. To improve measurement accuracy, sensitivity and efficiency, the resolution bandwidth can be different from the measurement bandwidth. When the resolution bandwidth is smaller than the measurement bandwidth, the result should be integrated over the measurement bandwidth in order to obtain the equivalent noise bandwidth of the measurement bandwidth.</p> <p>NOTE 4: Equivalent PSD type mask can be derived by applying <math>10 \cdot \log((10 \text{ MHz})/(30 \text{ kHz})) = 25,2 \text{ dB}</math> and <math>10 \cdot \log((10 \text{ MHz})/(1 \text{ MHz})) = 10 \text{ dB}</math> scaling factor for 30 kHz and 1 MHz measurement bandwidth respectively.</p>		

## 4.2.4 Transmitter Adjacent Channel Leakage power Ratio (ACLR)

### 4.2.4.1 Definition

Adjacent Channel Leakage power Ratio (ACLR) is the ratio of the mean power centred on the assigned channel frequency to the mean power centred on a first or second adjacent channel. The first adjacent and second adjacent channel centre offsets relative to the assigned channel centre frequency are exactly one channel bandwidth and two channel bandwidths. The measurement on the assigned and victim channel is performed using a rectangular filter with a bandwidth of 95 % of the channel bandwidth.

### 4.2.4.2 Limits

If the adjacent channel mean power is greater than -55 dBm then the ACLR shall be equal to or greater than the limits specified in table 5.

**Table 5: Mobile Terminal Station ACLR limits**

Adjacent channel	ACLR limit relative to assigned channel frequency [dB]
1 <sup>st</sup> adjacent channel	32,2
2 <sup>nd</sup> adjacent channel	42,2

## 4.2.5 Transmitter spurious emissions

### 4.2.5.1 Definition

Transmitter spurious emissions are here defined as any unwanted emissions falling in the defined frequency band of table 6.

#### 4.2.5.2 Limits

The following requirements are only applicable for frequencies, which are greater than 250 % of the channel bandwidth (e.g. 12,5 MHz for the 5 MHz, 17,5 MHz for the 7 MHz and 25 MHz for the 10 MHz channel bandwidth) away from the TS centre carrier frequency.

**Table 6: General transmitter spurious emissions requirements**

Frequency Band	Measurement Bandwidth	Minimum Requirements
30 MHz $\leq$ f < 1 GHz	100 kHz	-36 dBm
1 GHz < f < 19 GHz	30 kHz If $2,5 \times \text{BW} \leq  f_c - f  < 10 \times \text{BW}$	-30 dBm
	300 kHz If $10 \times \text{BW} \leq  f_c - f  < 12 \times \text{BW}$	-30 dBm
	1 MHz If $12 \times \text{BW} \leq  f_c - f $	-30 dBm

#### 4.2.6 Transmitter power control

##### 4.2.6.1 Definition

Transmit Power Control (TPC) is a mechanism used by the equipment to ensure a mitigation factor on the aggregate power from a large number of devices.

##### 4.2.6.2 Limits

For mobile terminal stations ATPC has to be implemented with a minimum power range of 15 dB. The ATPC should be implemented so that the minimum level is equal or less the 10 dBm/MHz.

#### 4.2.7 Receiver spurious emissions

##### 4.2.7.1 Definition

Receiver spurious emissions are emissions at any frequency, when the equipment is in receive mode. The spurious receiver emissions power is the power of emissions generated or amplified in a receiver that appear at the TS antenna connector.

##### 4.2.7.2 Limits

Receiver spurious emissions are defined for the whole frequency range, also within the 250 % of the channel bandwidth across the TS centre carrier frequency.

The power of any spurious emissions shall not exceed the limits given in table 7.

**Table 7: Receiver spurious emission requirements**

Frequency Band	Measurement Bandwidth	Minimum Requirements
30 MHz $\leq$ f < 1 GHz	100 kHz	-57 dBm
1 GHz < f < 19 GHz	1 MHz	-47 dBm

#### 4.2.8 Receiver adjacent and alternate channel rejection

##### 4.2.8.1 Definition

The receiver adjacent and alternate channel rejection is a measure of the receiver's ability to receive a wanted signal at its assigned channel frequency in the presence of an unwanted interferer at a given frequency offset from the centre frequency of the assigned channel, either at the adjacent or alternate channel, without this unwanted input signal causing a degradation of the performance of the receiver beyond a specified limit.

To reference the receiver adjacent and alternate channel rejection values, a sensitivity level is defined as the signal level for Bit Error Rate (BER)  $\leq 10^{-6}$  performance, over the channel bandwidth, corresponding to the most robust modulation and coding rate supported by the technology.

#### 4.2.8.2 Limits

Table 8 lists the receiver adjacent and alternate channel rejection. For the interferer the same channel bandwidth has to be used as for the assigned channel bandwidth. All the measurements are done over 95 % of the channel. The compliant system shall be able to meet a Bit Error Rate (BER)  $< 10^{-6}$  with the interference levels specified in table 10. Please note that depending on some assumed packet sizes, equivalent Packet Error Rate (PER) criteria can be used alternatively.

**Table 8: Receiver adjacent and alternate channel rejection**

Adjacent channel rejection (dB)	Alternate channel rejection (dB)
20	39

### 4.2.9 Control and monitoring functions

#### 4.2.9.1 Definition

This requirement, together with other control and monitoring technical requirements identified in table 1 of cross references in the applicable part, verifies that the control and monitoring functions of the UE prevent it from transmitting in the absence of a valid network.

This test is applicable to radio communications equipment and ancillary equipment.

This test shall be performed on the radio communications equipment and/or a representative configuration of the ancillary equipment.

#### 4.2.9.2 Limits

The maximum measured power during the duration of the test shall not exceed -30 dBm.

#### 4.2.9.3 Conformance

Conformance tests described in clause 5.4.7 shall be carried out.

---

## 5 Testing for compliance with technical requirements

### 5.1 Environmental conditions for testing

The technical requirements of the present document apply under the environmental profile, for intended operation of the equipment and antennas, declared by the manufacturer.

The environmental profile may be determined by the environmental class of the equipment according to the guidance given in EN 300 019 [1].

The combination of the equipment and its antennas shall comply with all the requirements of the present document at all times when operating within the boundary limits of the declared operational environmental profile.

## 5.2 Product information

The following information shall be stated by the manufacturer in order to carry out the test suites:

- the operating RF channel centre frequency range of the equipment;
- the nominal occupied channel bandwidth;
- the modulation format(s) employed by the equipment;
- the maximum output power and the associated maximum useable antenna gain for this power level;
- the TPC range(s);
- the operational environmental profile(s) applicable to the equipment.

## 5.3 Interpretation of the measurement results

The interpretation of the results recorded in a test report for the measurements described in the present document shall be as follows:

- the measured value related to the corresponding limit will be used to decide whether an equipment meets the requirements of the present document;
- the value of the measurement uncertainty for the measurement of each parameter shall be included in the test report;
- the recorded value of the measurement uncertainty shall be, for each measurement, equal to or lower than the figures in table 9.

For the test methods, according to the present document, the measurement uncertainty figures shall be calculated and shall correspond to an expansion factor (coverage factor)  $k = 1,96$  or  $k = 2$  (which provide confidence levels of respectively 95 % and 95,45 % in the case where the distributions characterizing the actual measurement uncertainties are normal (Gaussian)). Principles for the calculation of measurement uncertainty are contained in specific ETSI deliverables TR 100 028 [2] or TR 102 215 [3].

Table 9 is based on such expansion factors.

**Table 9: Maximum measurement uncertainty**

Parameter	Conditions	Uncertainty
5.4.1 Transmitter spectrum emission mask		±1,5 dB
5.4.2 Transmitter adjacent channel leakage power ratio (ACLR)	-	±0,8 dB
5.4.3 Transmitter spurious emissions	For TS and coexistence bands: for results < -60 dBm: for results > -60 dBm:	±3,0 dB ±2,0 dB
	Outside above: f ≤ 2,2 GHz: 2,2 GHz < f ≤ 4 GHz: 4 GHz < f:	±1,5 dB ±2,0 dB ±4,0 dB
5.4.4 Transmitter output power and transmit power control		±0,7 dB
5.4.5 Receiver spurious emissions	For TS receive and transmit band:	±3,0 dB
	Outside above: f ≤ 2,2 GHz: 2,2 GHz < f ≤ 4 GHz: 4 GHz < f:	±2,0 dB ±2,0 dB ±4,0 dB

## 5.4 Essential radio test suites

### 5.4.1 Transmitter spectrum emission mask

The purpose of this test is to verify compliance of mobile TS equipment to the spectrum mask emission requirements of clause 4.2.3.

#### 5.4.1.1 Method of test for mobile TS spectral emission mask

Figure 1 shows the test setup for testing mobile TS spectrum emission masks.

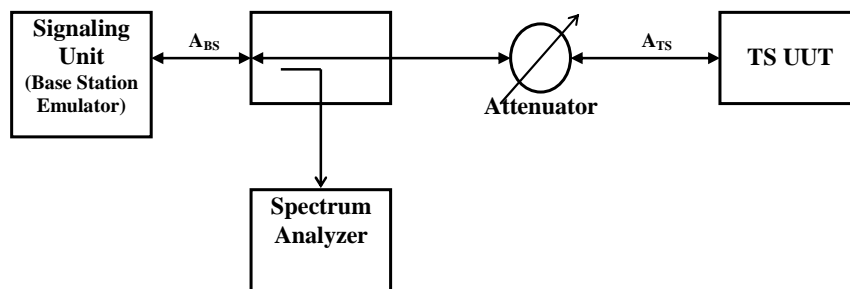

**Figure 1: Test setup for spectral mask emission testing**

##### 5.4.1.1.1 Initial conditions

The TS UUT shall be configured to operate at the maximum output power declared for the equipment.

For a TS UUT with antenna connector(s) and using external antenna(s), or for a UUT with integral antenna(s) but with a temporary antenna connector provided, conducted measurements shall be used.

For a TS UUT with integral antenna(s) and without a temporary antenna connector, radiated measurements shall be used.

For systems implementing dynamic change of the modulation order; this test shall be carried out for transient behaviour with the spectrum analyser in "maxhold" mode. The equipment shall be configured to operate with continuous modulation mode switching at the maximum switching speed permitted by the system, with equal duty cycle for all modulation orders, and with all training bursts or reference signals active as in normal operation.

- Step 1 In Spectrum Analyzer, set the resolution bandwidth to 30 kHz for the first 1 MHz of measurement from the edge of assigned channel and 1 MHz for the remaining of measurements and also set the video bandwidth to 30 kHz.

##### 5.4.1.1.2 Procedure

- Step 1 Set the RF channel to the lowest channel centre frequency from the declared range.
- Step 2 Make sure the data link connection has been established between TS UUT and Signaling Unit.
- Step 3 The TS UUT is configured to continuously transmit at the maximum power over allocated channel bandwidth.
- Step 4 Measure and note the signal spectrum over the range specified in clause 4.2.3.2 according the specified measurement bandwidths in the tables (tables 2, 3 or 4). Note that measurement aggregation is needed to compare with specified numbers according to the 1 MHz measurement bandwidth in the tables.
- Step 5 Repeat Steps 3 to 5 at the middle and highest RF channel center frequencies from the declared range.
- Step 6 Repeat Step 2 to 6 for all modulation schemes supported by the equipment under test.
- Step 7 End of test.

## 5.4.2 Transmitter adjacent channel leakage power ratio (ACLR)

The purpose of this test is to verify compliance of mobile TS equipment to the transmitter adjacent channel leakage power ratio requirements of clause 4.2.4.

### 5.4.2.1 Method of test for mobile TS ACLR

Figure 2 shows the test setup for testing mobile TS ACLR.

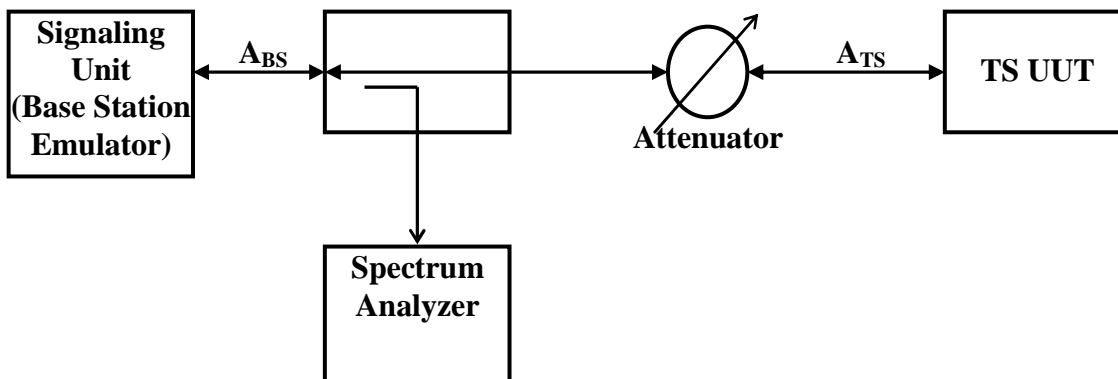

Figure 2: Test setup for ACLR testing

#### 5.4.2.1.1 Initial conditions

The UUT shall be configured to operate at the maximum output power declared for the equipment.

For a UUT with antenna connector(s) and using external antenna(s), or for a UUT with integral antenna(s) but with a temporary antenna connector provided, conducted measurements shall be used.

For a UUT with integral antenna(s) and without a temporary antenna connector, radiated measurements shall be used.

For systems implementing dynamic change of the modulation order, the equipment shall be configured to operate with continuous modulation mode switching at the maximum switching speed permitted by the system, with equal duty cycle for all modulation orders, and with all training bursts or reference signals active as in normal operation.

Step 1 In Spectrum Analyzer, set the resolution bandwidth to 100 kHz and the video bandwidth to 30 kHz.

#### 5.4.2.1.2 Procedure

Step 2 Set the RF channel to the lowest channel centre frequency from the declared range.

Step 3 Make sure the data link connection has been established between TS UUT and Signaling Unit.

Step 4 The TS UUT is configured to continuously transmit at the maximum output power.

Step 5 Measure the aggregated power measured over a frequency range equal to 95 % of the channel bandwidth centred on the assigned channel frequency.

Step 6 Average over a sufficient number of transmitted bursts to obtain a stable reading.

Step 7 Measure the aggregated power measured over a frequency range equal to 95 % of the channel bandwidth centred on the first lower adjacent channel frequency apart from operating RF channel center frequency.

Step 8 Average over a sufficient number of transmitted bursts to obtain a stable reading.

Step 9 Calculate the ACLR by: (Power according to Step 6)/(Power according to Step 8).

Step 10 Repeat Steps 5 to 9 for the second lower adjacent RF channel and also for the first and second upper adjacent RF channel.

Step 11 Repeat Steps 3 to 10 at the middle and highest RF channel center frequencies from the declared range.



Step 12 End of test.

### 5.4.3 Transmitter spurious emissions

#### 5.4.3.1 Method of test for mobile TS transmitter spurious emission

Figure 3 shows the test setup for testing mobile TS transmitter spurious emission.

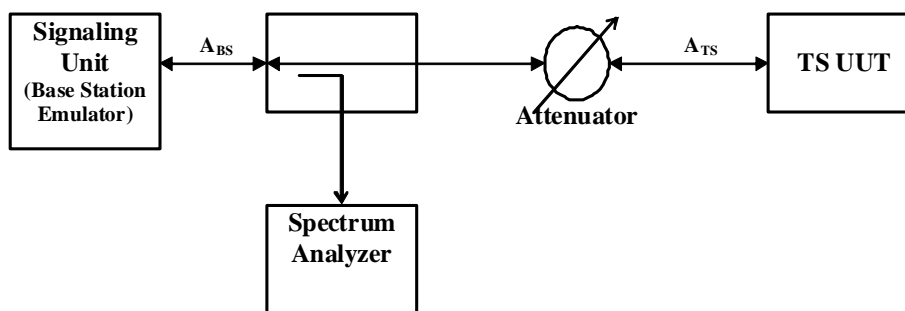

**Figure 3: Test Setup for transmitter spurious emission testing**

##### 5.4.3.1.1 Initial conditions

The TS UUT shall be configured to operate at the maximum output power declared for the equipment.

For a TS UUT with antenna connector(s) and using external antenna(s), or for a UUT with integral antenna(s) but with a temporary antenna connector provided, conducted measurements shall be used.

For a TS UUT with integral antenna(s) and without a temporary antenna connector, radiated measurements shall be used.

- Step 1 In Spectrum Analyzer, set the measurement bandwidth as specified in the relevant table 6. Set the video bandwidth to 30 kHz.

For systems implementing dynamic change of the modulation order, the equipment shall be configured to operate with continuous modulation mode switching at the maximum switching speed permitted by the system, with equal duty cycle for all modulation orders, and with all training bursts or reference signals active as in normal operation.

##### 5.4.3.1.2 Procedure

- Step 2 Set the RF channel at lowest channel centre frequency.
- Step 3 Make sure the data link connection has been established between TS UUT and Signaling Unit.
- Step 4 The TS UUT is configured to continuously transmit at the maximum output power as measured over the allocated channel bandwidth.
- Step 5 Measure and note the transmitter spurious emissions over the range specified in table 6 according to the specified measurement bandwidths in the table.
- Step 6 Repeat Steps 3 to 5 at middle and highest RF channel center frequencies from the declared range.
- Step 7 End of test.

### 5.4.4 Transmitter output power and transmit power control

The purpose of this test is to verify compliance of the transmitter output power and transmit power control of mobile TS equipment in support of requirements in clauses 4.2.2 and 4.2.6.

### 5.4.4.1 Method of test

Figure 4 shows the test setup for testing transmitter output power and transmit power control. In this figure, two way arrows represent possible protocol messages exchanged between Signaling Unit and TS UUT to configure TS UUT for proper transmission with specified power levels. Obviously, power transmissions from the TS UUT are one way in uplink and from right to left in figure 4.

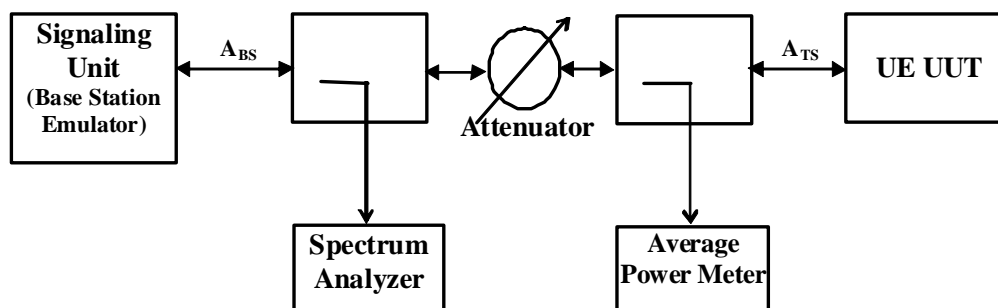

**Figure 4: Test setup for transmitter output power and transmit power control**

#### 5.4.4.1.1 Initial conditions

The UUT shall be configured to operate at the maximum output power declared for the equipment.

#### 5.4.4.1.2 Procedure

- Step 1 Set the RF channel to the lowest channel centre frequency from the declared range.
- Step 2 Make sure the data link connection has been established between TS UUT and Signaling Unit.
- Step 3 The TS UUT is configured to continuously transmit at the maximum output power as measured over the allocated channel bandwidth.
- Step 4 Measure and note output power level and power density for compliance with the maximum radiated power density limit and output power tolerance in clause 4.2.2. The radiated power density shall be calculated from the measured power density using the declared antenna gain by the manufacturer.
- Step 5 Have Signaling Unit to instruct TS UUT to decrease the transmit power in steps of 1 dB down to the point that the power can not be reduced further.
- Step 6 Make note of the difference between in measured output power level of Step 4 and the lowest power level in Step 5 to be compared with the 15 dB transmit power control range of clause 4.2.6.
- Step 7 Repeat Steps 3 to 6 at the middle and highest RF channel center frequencies from the declared range.
- Step 8 Repeat Step 2 to 6 for all modulation schemes supported by the TS UUT.
- Step 9 End of test.

## 5.4.5 Receiver spurious emissions

### 5.4.5.1 Method of test

Figure 5 shows the test setup for testing mobile TS receiver spurious emission.

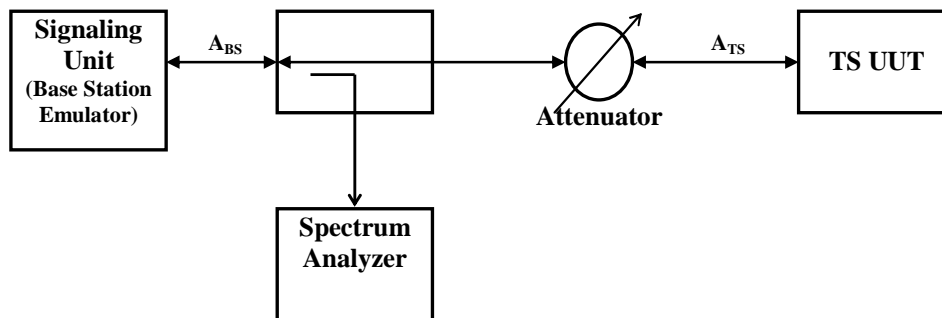

**Figure 5: Test setup for receiver spurious emission testing**

#### 5.4.5.1.1 Initial conditions

In Spectrum Analyzer, set the measurement bandwidth as specified in table 7. Set the video bandwidth to 30 kHz.

#### 5.4.5.1.2 Procedure

- Step 1 Set the RF channel at lowest channel centre frequency.
- Step 2 Make sure the data link connection has been established between TS UUT and Signaling Unit.
- Step 3 The TS UUT is configured to transmit at the maximum output power as measured over the allocated channel bandwidth.
- Step 4 Measure and note the mobile TS receiver spurious emissions over the range specified in table 7 according to the specified measurement bandwidths in the table. The receiver spurious emissions should be only measured during the receive part of the TDD frame.
- Step 5 Repeat Steps 3 to 5 at middle and highest RF channel center frequencies from the declared range.
- Step 6 End of test.

### 5.4.6 Receiver adjacent and alternate channel rejection

#### 5.4.6.1 Method of test

Interfering source shall be a conforming unsynchronized signal with the same signalling technology as the in-channel signal.

#### 5.4.6.1.1 Procedure

- Step 1 Set the RF channel at lowest channel centre frequency.
- Step 2 Adjust the received signal level at  $A_{UUT}$  to be 3 dB above the sensitivity level  $P_{SENS} + 3$  under AWGN channel condition. Note the signal level is measured over the time period of the data burst only within the downlink transmission.
- Step 3 Turn on the interfering source and configure it to transmit at  $f_c -$  channel bandwidth.
- Step 4 Increase the interfering source power to  $P_{SENS} + 23$ .
- Step 5 Perform a BER measurement and record the results.
- Step 6 Turn the interference source off.
- Step 7 Repeat Step 1 to Step 6 above for the other test cases shown in table 10.
- Step 8 Repeat the test procedure at middle and highest channel center frequencies from the declared range.

**Table 10: Test parameters for receiver adjacent and alternate channel rejection**

Test Levels	Adjacent channel	Alternate channel
In-channel power level (dBm)	$P_{\text{SENS}} + 3$	$P_{\text{SENS}} + 3$
Interferer power level (dBm)	$P_{\text{SENS}} + 23$	$P_{\text{SENS}} + 42$
Interferer center frequency (MHz)	$f_c \pm \text{channel bandwidth}$	$f_c \pm 2 \times \text{channel bandwidth}$

$P_{\text{SENS}}$  is the sensitivity levels at  $\text{BER} \leq 10^{-6}$ , corresponding to the most robust modulation and coding rate supported by the technology.

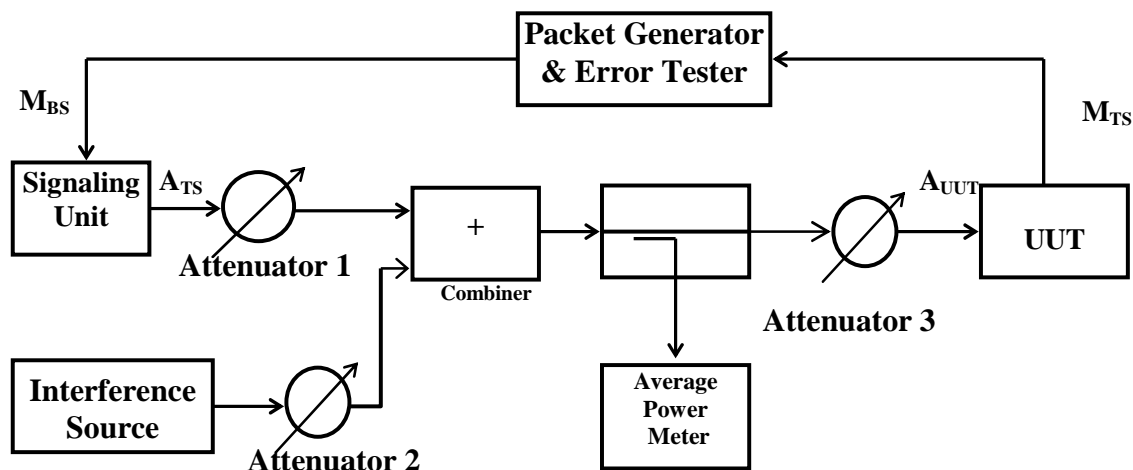
**Figure 6: Test setup for receiver adjacent and alternate channel rejection test**

## 5.4.7 Control and monitoring functions

### 5.4.7.1 Method of test

- a) At the start of the test, the TS shall be switched off. The TS antenna connector shall be connected to a power measuring equipment, with the following characteristics:
  - the RF bandwidth shall exceed the total operating transmit frequency range of the TS for operation with an applicable part;
  - the response time of the power measuring equipment shall be such that the measured power has reached within 1 dB of its steady state value within 100  $\mu\text{s}$  of a CW signal being applied;
  - it shall record the maximum power measured.

NOTE: The equipment may include a video low pass filter to minimize its response to transients or Gaussian noise peaks.

- b) The TS shall be switched on for a period of approximately fifteen minutes, and then switched off.
- c) The TS shall remain switched off for a period of at least thirty seconds, and shall then be switched on for a period of approximately one minute.
- d) Step c) shall be repeated four times.
- e) The maximum power emitted from the TS throughout the duration of the test shall be recorded. The results obtained shall be compared to the limits in clause 4.2.9.2 in order to prove compliance.

## Annex A (normative): HS Requirements and conformance Test specifications Table (HS-RTT)

The HS Requirements and conformance Test specifications Table (HS-RTT) in table A.1 serves a number of purposes, as follows:

- it provides a statement of all the requirements in words and by cross reference to (a) specific clause(s) in the present document or to (a) specific clause(s) in (a) specific referenced document(s);
- it provides a statement of all the test procedures corresponding to those requirements by cross reference to (a) specific clause(s) in the present document or to (a) specific clause(s) in (a) specific referenced document(s);
- it qualifies each requirement to be either:
  - Unconditional: meaning that the requirement applies in all circumstances, or
  - Conditional: meaning that the requirement is dependant on the manufacturer having chosen to support optional functionality defined within the schedule.
- in the case of Conditional requirements, it associates the requirement with the particular optional service or functionality;
- it qualifies each test procedure to be either:
  - Essential: meaning that it is included with the Essential Radio Test Suite and therefore the requirement shall be demonstrated to be met in accordance with the referenced procedures;
  - Other: meaning that the test procedure is illustrative but other means of demonstrating compliance with the requirement are permitted.

**Table A.1: HS Requirements and conformance Test specifications Table (HS-RTT)**

<b>Harmonized Standard EN 302 623</b>						
The following requirements and test specifications are relevant to the presumption of conformity under the Article 3.2 of the R&TTE Directive						
<b>Requirement</b>			<b>Requirement Conditionality</b>		<b>Test Specification</b>	
<b>No</b>	<b>Description</b>	<b>Reference: Clause No</b>	<b>U/ C</b>	<b>Condition</b>	<b>E/O</b>	<b>Reference: Clause No</b>
1	Transmitter output power	4.2.2	U		E	5.4.4
2	Transmitter spectrum emission mask	4.2.3	U		E	5.4.1
3	Transmitter adjacent channel leakage power ratio (ACLR)	4.2.4	U		E	5.4.2
4	Transmitter spurious emissions	4.2.5	U		E	5.4.3
5	Transmit power control	4.2.6	U		E	5.4.4
6	Receiver spurious emissions	4.2.7	U		E	5.4.5
7	Receiver adjacent and alternate channel rejection	4.2.8	U		E	5.4.6
7	Control and monitoring functions	4.2.9	U		E	5.4.7

### Key to columns:

#### Requirement:

**No** A unique identifier for one row of the table which may be used to identify a requirement or its test specification.

**Description** A textual reference to the requirement.

**Clause Number** Identification of clause(s) defining the requirement in the present document unless another document is referenced explicitly.

**Requirement Conditionality:**

**U/C** Indicates whether the requirement is to be *unconditionally* applicable (U) or is *conditional* upon the manufacturers claimed functionality of the equipment (C).

**Condition** Explains the conditions when the requirement shall or shall not be applicable for a technical requirement which is classified "conditional".

**Test Specification:**

**E/O** Indicates whether the test specification forms part of the Essential Radio Test Suite (E) or whether it is one of the Other Test Suite (O).

NOTE: All tests whether "E" or "O" are relevant to the requirements. Rows designated "E" collectively make up the Essential Radio Test Suite; those designated "O" make up the Other Test Suite; for those designated "X" there is no test specified corresponding to the requirement. The completion of all tests classified "E" as specified with satisfactory outcomes is a necessary condition for a presumption of conformity. Compliance with requirements associated with tests classified "O" or "X" is a necessary condition for presumption of conformity, although conformance with the requirement may be claimed by an equivalent test or by manufacturer's assertion supported by appropriate entries in the technical construction file.

**Clause Number** Identification of clause(s) defining the test specification in the present document unless another document is referenced explicitly Where no test is specified (that is, where the previous field is "X") this field remains blank.

## Annex B (informative): The EN title in the official languages

Language	EN title
Bulgarian	
Czech	
Danish	
Dutch	
English	Broadband Wireless Access Systems (BWA) in the 3 400 MHz to 3 800 MHz frequency band; Mobile Terminal Stations; Harmonized EN covering the essential requirements of article 3.2 of the R&TTE Directive
Estonian	
Finnish	
French	
German	
Greek	
Hungarian	
Icelandic	
Italian	
Latvian	
Lithuanian	
Maltese	
Norwegian	
Polish	
Portuguese	
Romanian	
Slovak	
Slovenian	
Spanish	
Swedish	

---

## Annex C (informative): Bibliography

ECC/DEC/(07)02: "ECC Decision of 30 March 2007 on availability of frequency bands between 3400-3800 MHz for the harmonized implementation of Broadband Wireless Access systems(BWA)" Electronic Communications Committee.

Commission Decision of [...] on the harmonization of the 3400-3800 MHz frequency band for terrestrial systems capable of providing electronic communications services in the Community.



---

## History

<b>Document history</b>			
V0.3.2	May 2008	Public Enquiry	PE 20080905: 2008-05-07 to 2008-09-05