



HARMONISED EUROPEAN STANDARD

**Satellite Earth Stations and Systems (SES);
Harmonised Standard for Satellite Earth Stations (MES) for
MSS operating in the 2 GHz frequency band;
Part 1: Complementary Ground
Component (CGC) for wideband systems
covering the essential requirements
of article 3.2 of the Directive 2014/53/EU**

Reference

REN/SES-00369

Keywords

broadband, IMT, mobile, satellite

ETSI

650 Route des Lucioles
F-06921 Sophia Antipolis Cedex - FRANCE

Tel.: +33 4 92 94 42 00 Fax: +33 4 93 65 47 16

Siret N° 348 623 562 00017 - NAF 742 C
Association à but non lucratif enregistrée à la
Sous-Préfecture de Grasse (06) N° 7803/88

Important notice

The present document can be downloaded from:
<http://www.etsi.org/standards-search>

The present document may be made available in electronic versions and/or in print. The content of any electronic and/or print versions of the present document shall not be modified without the prior written authorization of ETSI. In case of any existing or perceived difference in contents between such versions and/or in print, the only prevailing document is the print of the Portable Document Format (PDF) version kept on a specific network drive within ETSI Secretariat.

Users of the present document should be aware that the document may be subject to revision or change of status. Information on the current status of this and other ETSI documents is available at
<https://portal.etsi.org/TB/ETSIDeliverableStatus.aspx>

If you find errors in the present document, please send your comment to one of the following services:
<https://portal.etsi.org/People/CommiteeSupportStaff.aspx>

Copyright Notification

No part may be reproduced or utilized in any form or by any means, electronic or mechanical, including photocopying and microfilm except as authorized by written permission of ETSI.

The content of the PDF version shall not be modified without the written authorization of ETSI.
The copyright and the foregoing restriction extend to reproduction in all media.

© European Telecommunications Standards Institute 2016.
All rights reserved.

DECT™, **PLUGTESTS™**, **UMTS™** and the ETSI logo are Trade Marks of ETSI registered for the benefit of its Members.
3GPP™ and **LTE™** are Trade Marks of ETSI registered for the benefit of its Members and of the 3GPP Organizational Partners.
GSM® and the GSM logo are Trade Marks registered and owned by the GSM Association.

Contents

Intellectual Property Rights	9
Foreword.....	9
Modal verbs terminology.....	9
Introduction	10
1 Scope	11
2 References	12
2.1 Normative references	12
2.2 Informative references.....	13
3 Definitions, symbols and abbreviations	13
3.1 Definitions	13
3.2 Symbols.....	14
3.3 Abbreviations	15
4 Technical requirements specifications for conventional CGC	16
4.1 Environmental profile.....	16
4.2 Conformance requirements	16
4.2.1 Introduction.....	16
4.2.2 Spectrum emission mask	16
4.2.2.1 Definition	16
4.2.2.2 Limits	17
4.2.2.3 Conformance.....	18
4.2.3 Adjacent channel leakage power ratio (ACLR).....	18
4.2.3.1 Definition	18
4.2.3.2 Limits	18
4.2.3.3 Conformance.....	19
4.2.4 Transmitter spurious emissions.....	19
4.2.4.1 Definition	19
4.2.4.2 Limits	19
4.2.4.2.1 Spurious emissions	19
4.2.4.2.2 Coexistence with other systems in the same geographical area.....	20
4.2.4.2.3 Protection of UTRA FDD in adjacent frequency band.....	20
4.2.4.2.4 Protection of UTRA -TDD	20
4.2.4.2.5 Protection of UTRA BS.....	20
4.2.4.2.6 Protection of the CGC receiver of own or different CGC	21
4.2.4.3 Conformance.....	21
4.2.5 CGC maximum output power	21
4.2.5.1 Definition	21
4.2.5.2 Limit.....	21
4.2.5.3 Conformance.....	21
4.2.6 Transmit inter modulation	21
4.2.6.1 Definition	21
4.2.6.2 Limit.....	22
4.2.6.3 Conformance.....	22
4.2.7 Receiver spurious emissions	22
4.2.7.1 Definition	22
4.2.7.2 Limits	22
4.2.7.3 Conformance.....	22
4.2.8 Blocking characteristics	22
4.2.8.1 Definition	22
4.2.8.2 Limit.....	22
4.2.8.3 Conformance.....	23
4.2.9 Receiver inter-modulation characteristics.....	23
4.2.9.1 Definition	23
4.2.9.2 Limit.....	23
4.2.9.3 Conformance.....	24

4.2.10	Receiver adjacent selectivity.....	24
4.2.10.1	Definition	24
4.2.10.2	Limit.....	24
4.2.10.3	Conformance.....	25
5	Testing for compliance with technical requirements for conventional CGC	25
5.1	Environmental and other conditions for testing.....	25
5.2	Interpretation of the measurement results	26
5.3	Radio test suites.....	27
5.3.1	Spectrum emission mask	27
5.3.1.1	Initial conditions	27
5.3.1.2	Procedures.....	28
5.3.2	Adjacent Channel leakage Power Ratio (ACLR).....	28
5.3.2.1	Initial conditions	28
5.3.2.2	Procedure	28
5.3.3	Transmitter spurious emissions.....	28
5.3.3.1	Initial conditions	28
5.3.3.2	Procedure	29
5.3.4	CGC maximum output power.....	29
5.3.4.1	Initial conditions	29
5.3.4.2	Procedure	29
5.3.5	Transmit intermodulation	29
5.3.5.1	Initial conditions	29
5.3.5.2	Procedures.....	29
5.3.6	Receiver spurious emissions	30
5.3.6.1	Initial conditions	30
5.3.6.2	Procedure	30
5.3.7	Blocking characteristics.....	30
5.3.7.1	Initial conditions	30
5.3.7.2	Procedure	31
5.3.8	Receiver intermodulation characteristics	31
5.3.8.1	Initial conditions	31
5.3.8.2	Procedures.....	31
5.3.9	Receiver Adjacent Channel Selectivity (ACS).....	31
5.3.9.1	Initial conditions	31
5.3.9.2	Procedure	32
6	Technical requirements specifications for Aeronautical CGC	32
6.1	Environmental profile.....	32
6.2	Conformance requirements	32
6.2.1	Introduction.....	32
6.2.2	Spectrum emission mask	33
6.2.2.1	Definition	33
6.2.2.2	Limits	33
6.2.2.3	Conformance.....	33
6.2.3	Adjacent channel leakage power ratio (ACLR).....	33
6.2.3.1	Definition	33
6.2.3.2	Limits	33
6.2.3.3	Conformance.....	34
6.2.4	Transmitter spurious emissions.....	34
6.2.4.1	Definition	34
6.2.4.2	Limits	34
6.2.4.2.1	CGC Spurious emissions	34
6.2.4.2.2	Coexistence with other systems.....	34
6.2.4.2.3	Protection of BS receiver.....	35
6.2.4.3	Conformance.....	35
6.2.5	Aeronautical CGC maximum output power	36
6.2.5.1	Definition	36
6.2.5.2	Limit.....	36
6.2.5.3	Conformance.....	36
6.2.6	Transmit intermodulation	36
6.2.6.1	Definition	36

6.2.6.2	Limit.....	36
6.2.6.3	Conformance.....	37
6.2.7	Receiver spurious emissions.....	37
6.2.7.1	Definition.....	37
6.2.7.2	Limits.....	37
6.2.7.3	Conformance.....	37
6.2.8	Blocking characteristics.....	37
6.2.8.1	Definition.....	37
6.2.8.2	Limit.....	37
6.2.8.3	Conformance.....	38
6.2.9	Receiver intermodulation characteristics.....	38
6.2.9.1	Definition.....	38
6.2.9.2	Limit.....	38
6.2.9.3	Conformance.....	39
6.2.10	Receiver adjacent Channel selectivity and narrow-band blocking.....	39
6.2.10.1	Definition.....	39
6.2.10.2	Limit.....	39
6.2.10.3	Conformance.....	40
7	Testing for compliance with technical requirements for Aeronautical CGC.....	40
7.1	Environmental and other conditions for testing.....	40
7.2	Interpretation of the measurement results.....	41
7.3	Radio test suites.....	42
7.3.1	Spectrum emission mask.....	42
7.3.1.1	Initial conditions.....	42
7.3.1.2	Procedures.....	43
7.3.2	Adjacent Channel leakage Power Ratio (ACLR).....	43
7.3.2.0	General.....	43
7.3.2.1	Initial conditions.....	43
7.3.2.2	Procedure.....	43
7.3.3	Transmitter spurious emissions.....	43
7.3.3.1	Initial conditions.....	43
7.3.3.2	Procedure.....	44
7.3.4	Aeronautical CGC maximum output power.....	44
7.3.4.1	Initial conditions.....	44
7.3.4.2	Procedure.....	44
7.3.5	Transmit intermodulation.....	44
7.3.5.1	Initial conditions.....	44
7.3.5.2	Procedures.....	45
7.3.6	Receiver spurious emissions.....	45
7.3.6.1	Initial conditions.....	45
7.3.6.2	Procedure.....	45
7.3.7	Blocking characteristics.....	46
7.3.7.1	Initial conditions.....	46
7.3.7.2	Procedure.....	46
7.3.8	Receiver intermodulation characteristics.....	46
7.3.8.1	Initial conditions.....	46
7.3.8.2	Procedures.....	47
7.3.9	Receiver Adjacent Channel Selectivity (ACS).....	47
7.3.9.1	Initial conditions.....	47
7.3.9.2	Procedure for Adjacent Channel Selectivity.....	47
7.3.9.3	Procedure for narrow-band blocking.....	47
8	Technical requirements specifications for conventional CGC E-UTRA.....	48
8.1	Environmental profile.....	48
8.2	Conformance requirements.....	48
8.2.1	Introduction.....	48
8.2.2	Operating band unwanted emissions.....	49
8.2.2.0	General.....	49
8.2.2.1	Definition.....	49
8.2.2.2	Limits.....	50
8.2.2.2.0	General.....	50

8.2.2.2.1	Limits for Wide Area CGC	50
8.2.2.2.2	Limits for Local Area CGC	50
8.2.2.3	Conformance.....	50
8.2.3	Adjacent Channel Leakage power Ratio (ACLR)	51
8.2.3.1	Definition	51
8.2.3.2	Limits	51
8.2.3.3	Conformance.....	51
8.2.4	Transmitter spurious emissions.....	51
8.2.4.0	General	51
8.2.4.1	Definition	52
8.2.4.2	Limits	52
8.2.4.2.1	Spurious emissions	52
8.2.4.2.2	Co-existence with other systems	52
8.2.4.2.3	Protection of BS receiver.....	53
8.2.4.3	Conformance.....	53
8.2.5	CGC BS maximum output power	53
8.2.5.0	General	53
8.2.5.1	Definition	53
8.2.5.2	Limit.....	54
8.2.5.3	Conformance.....	54
8.2.6	Transmitter intermodulation	54
8.2.6.0	General	54
8.2.6.1	Definition	54
8.2.6.2	Limit.....	54
8.2.6.3	Conformance.....	55
8.2.7	Receiver spurious emissions	55
8.2.7.0	General	55
8.2.7.1	Definition	55
8.2.7.2	Limit.....	55
8.2.7.3	Conformance.....	55
8.2.8	Blocking characteristics	56
8.2.8.0	General	56
8.2.8.1	Definition	56
8.2.8.2	Limit.....	56
8.2.8.3	Conformance.....	57
8.2.9	Receiver intermodulation characteristics	57
8.2.9.0	General	57
8.2.9.1	Definition	57
8.2.9.2	Limit.....	57
8.2.9.3	Conformance.....	58
8.2.10	Adjacent Channel Selectivity (ACS) and narrow-band blocking	58
8.2.10.0	General	58
8.2.10.1	Definition	59
8.2.10.2	Limit.....	59
8.2.10.3	Conformance.....	60
9	Testing for compliance with technical requirements for conventional CGC E-UTRA.....	60
9.1	Environmental conditions for testing	60
9.2	Interpretation of the measurement results	61
9.3	Radio test suites.....	62
9.3.0	General.....	62
9.3.1	Operating band unwanted emissions	62
9.3.1.0	General	62
9.3.1.1	Initial conditions	62
9.3.1.2	Procedure	62
9.3.2	Adjacent Channel Leakage power Ratio (ACLR)	63
9.3.2.1	Initial conditions	63
9.3.2.2	Procedure	63
9.3.3	Transmitter spurious emissions.....	63
9.3.3.0	General	63
9.3.3.1	Initial conditions	63
9.3.3.2	Procedure	63

9.3.4	CGC maximum output power.....	64
9.3.4.0	General.....	64
9.3.4.1	Initial conditions.....	64
9.3.4.2	Procedure.....	64
9.3.5	Transmitter intermodulation.....	64
9.3.5.0	General.....	64
9.3.5.1	Initial conditions.....	64
9.3.5.2	Procedures.....	64
9.3.6	Receiver spurious emissions.....	65
9.3.6.0	General.....	65
9.3.6.1	Initial conditions.....	65
9.3.6.2	Procedure.....	65
9.3.7	Blocking characteristics.....	66
9.3.7.0	General.....	66
9.3.7.1	Initial conditions.....	66
9.3.7.2	Procedure.....	66
9.3.8	Receiver intermodulation characteristics.....	67
9.3.8.0	General.....	67
9.3.8.1	Initial conditions.....	67
9.3.8.2	Procedures.....	67
9.3.9	Adjacent Channel Selectivity (ACS) and narrow-band blocking.....	67
9.3.9.0	General.....	67
9.3.9.1	Initial conditions.....	67
9.3.9.2	Procedure for Adjacent Channel Selectivity.....	67
9.3.9.3	Procedure for narrow-band blocking.....	68
Annex A (normative):	Relationship between the present document and the essential requirements of Directive 2014/53/EU.....	69
Annex B (normative):	Complementary Ground Component configurations.....	71
B.1	Receiver diversity.....	71
B.2	Duplexers.....	71
B.3	Splitters.....	71
B.4	Power supply options.....	72
B.5	Ancillary RF amplifiers.....	72
B.6	CGC using antenna arrays.....	73
B.6.0	General.....	73
B.6.1	Receiver tests.....	73
B.6.2	Transmitter tests.....	73
B.7	Transmit diversity.....	74
B.8	CGC with integrated Iuant CGC modem.....	74
B.9	Combining of CGCs.....	74
Annex C (informative):	Environmental profile specification.....	75
C.0	General.....	75
C.1	Tests environment.....	75
C.1.1	Measurement of test environments.....	75
C.1.2	Normal test Environment.....	75
C.1.3	Extreme test environment.....	76
C.1.4	Extreme temperature.....	76
C.1.5	Vibration.....	76
C.1.6	Power supply.....	76
C.1.7	Definition of Additive White Gaussian Noise (AWGN) Interferer.....	77
Annex D (informative):	Measurement system set-up.....	78

D.0	General	78
D.1	Transmitter	78
D.1.1	Maximum output power	78
D.1.2	Out of band emission.....	78
D.1.3	Transmit intermodulation	79
D.2	Receiver.....	79
D.2.1	Adjacent Channel Selectivity (ACS).....	79
D.2.2	Blocking characteristics	80
D.2.3	Intermodulation characteristics	80
D.2.4	Receiver spurious emission	81
Annex E (informative):	Bibliography.....	82
History		83

Intellectual Property Rights

IPRs essential or potentially essential to the present document may have been declared to ETSI. The information pertaining to these essential IPRs, if any, is publicly available for **ETSI members and non-members**, and can be found in ETSI SR 000 314: "*Intellectual Property Rights (IPRs); Essential, or potentially Essential, IPRs notified to ETSI in respect of ETSI standards*", which is available from the ETSI Secretariat. Latest updates are available on the ETSI Web server (<https://ipr.etsi.org>).

Pursuant to the ETSI IPR Policy, no investigation, including IPR searches, has been carried out by ETSI. No guarantee can be given as to the existence of other IPRs not referenced in ETSI SR 000 314 (or the updates on the ETSI Web server) which are, or may be, or may become, essential to the present document.

Foreword

This draft Harmonised European Standard (EN) has been produced by ETSI Technical Committee Satellite Earth Stations and Systems (SES), and is now submitted for the combined Public Enquiry and Vote phase of the ETSI standards EN Approval Procedure.

The present document has been prepared under the Commission's standardisation request C(2015) 5376 final [i.9] to provide one voluntary means of conforming to the essential requirements of Directive 2014/53/EU on the harmonisation of the laws of the Member States relating to the making available on the market of radio equipment and repealing Directive 1999/5/EC [13].

Once the present document is cited in the Official Journal of the European Union under that Directive, compliance with the normative clauses of the present document given in table A.1 confers, within the limits of the scope of the present document, a presumption of conformity with the corresponding essential requirements of that Directive, and associated EFTA regulations.

The present document is part 1 of a multi-part deliverable covering the Harmonised Standard for satellite earth stations for MSS operating in the 1 980 MHz to 2 010 MHz (earth-to-space) and 2 170 MHz to 2 200 MHz (space-to-earth) frequency bands, as identified below:

- Part 1:** "Complementary Ground Component (CGC) for wideband systems covering the essential requirements of article 3.2 of the Directive 2014/53/EU";
- Part 2: "User Equipment (UE) for wideband systems covering the essential requirements of article 3.2 of the Directive 2014/53/EU";
- Part 3: "User Equipment (UE) for narrowband systems covering the essential requirements of article 3.2 of the Directive 2014/53/EU".

Proposed national transposition dates	
Date of latest announcement of this EN (doa):	3 months after ETSI publication
Date of latest publication of new National Standard or endorsement of this EN (dop/e):	6 months after doa
Date of withdrawal of any conflicting National Standard (dow):	18 months after doa

Modal verbs terminology

In the present document "**shall**", "**shall not**", "**should**", "**should not**", "**may**", "**need not**", "**will**", "**will not**", "**can**" and "**cannot**" are to be interpreted as described in clause 3.2 of the [ETSI Drafting Rules](#) (Verbal forms for the expression of provisions).

"**must**" and "**must not**" are **NOT** allowed in ETSI deliverables except when used in direct citation.

Introduction

The present document is part of a set of standards developed by ETSI and is designed to fit in a modular structure to cover all radio equipment within the scope of the RE Directive [13]. The modular structure is shown in ETSI EG 201 399 [i.3].

The technical requirements in the present document are adapted from the requirements in ETSI EN 301 908-1 [3], ETSI EN 301 908-3 [4] and ETSI EN 301 908-14 [10]. The adaptations include a variable channel bandwidth and frequency band changes to the MSS band.

1 Scope

The present document applies to Complementary Ground Components (CGC) operating as part of a satellite network.

The present document covers two types of CGC:

- Conventional CGC:
 - Clauses 4 and 5 according to ETSI EN 301 908-18 [16] for W-CDMA
 - Clauses 8 and 9 according to ETSI EN 301 908-14 [10] for E-UTRA
- Aeronautical CGC

These Complementary Ground Components (CGC) transmit only to the User Equipment/ Aeronautical Terminal or transmit and receive to/from the User Equipment/ Aeronautical Terminal in the frequency bands allocated to the Mobile Satellite Service (MSS) on a primary basis as defined in table 1.

NOTE 1: The CGC may include various types of interfaces, to terrestrial and/or satellite networks, but their specifications are out of the scope of the present document.

The present document applies to Complementary Ground Component (CGC) radio equipment type deployed in Mobile Satellite Services systems which have the following characteristics:

- These CGCs may have both transmit and receive capabilities and are part of a hybrid Satellite/terrestrial network.
- These CGCs operate with an assigned channel signal bandwidth (CBw) of 1 MHz or greater.
- The conventional CGCs may be local coverage, medium coverage or wide coverage ground components.
- The aeronautical CGCs may transmit/receive toward/from terminal mounted on aircraft (Aeronautical Terminal).
- These CGCs may be an element in a multi-mode base station. It may consist of a number of modules with associated connections, or may be a self-contained single unit.

If the CGC is an element in a multi-mode base station, unless otherwise stated in the present document, its requirements apply only to the CGC element of the terminal operating in the Mobile Satellite Service (MSS) frequency bands given in table 1.

The present document applies to the following terminal equipment types:

- 1) Complementary Ground Components for Wideband Satellite Systems.

This radio equipment type is capable of operating in all or any part of the frequency bands given in table 1.

Table 1: Mobile Satellite Service Complementary Ground Component frequency bands

Operating band	Direction of transmission	CGC frequency bands
1	Transmit	2 170 MHz to 2 200 MHz
	Receive	1 980 MHz to 2 010 MHz

The present document only applies to the radio interface between the conventional CGC and the User Equipment or between aeronautical CGC and Aeronautical Terminal.

The present document is intended to cover the provisions of Directive 2014/53/EU [13] (RE Directive) article 3.2 which states, which states that "*Radio equipment shall be so constructed that it both effectively uses and supports the efficient use of radio spectrum in order to avoid harmful interference*".

NOTE 2: In addition to the unwanted emission limits defined in clauses 4.2.2 and 5.2.2 of the present document, additional operational constraints may be required to prevent harmful interference into services operating in the neighbouring bands outside the operational band defined in table 1.

In addition to the present document, other ENs that specify technical requirements in respect of essential requirements under other parts of article 3 of the Directive 2014/53/EU [13] may apply to equipment within the scope of the present document.

NOTE 3: A list of such ENs is included on the web site <http://www.newapproach.org>.

2 References

2.1 Normative references

References are either specific (identified by date of publication and/or edition number or version number) or non-specific. For specific references, only the cited version applies. For non-specific references, the latest version of the referenced document (including any amendments) applies.

Referenced documents which are not found to be publicly available in the expected location might be found at <http://docbox.etsi.org/Reference>.

NOTE: While any hyperlinks included in this clause were valid at the time of publication, ETSI cannot guarantee their long term validity.

The following referenced documents are necessary for the application of the present document.

- [1] Void.
- [2] ETSI TS 125 141 (V11.8.0) (04-2014): "Universal Mobile Telecommunications System (UMTS); Base Station (BS) conformance testing (FDD) (3GPP TS 25.141 version 11.8.0 Release 11)".
- [3] ETSI EN 301 908-1 (V6.2.1) (04-2013): "IMT cellular networks; Harmonized EN covering the essential requirements of article 3.2 of the R&TTE Directive; Part 1: Introduction and common requirements".
- [4] ETSI EN 301 908-3 (V6.2.1) (10-2013): "IMT cellular networks; Harmonized EN covering the essential requirements of article 3.2 of the R&TTE Directive; Part 3: CDMA Direct Spread (UTRA FDD) Base Stations (BS)".
- [5] Recommendation ITU-R SM.329-12 (09-2012): "Unwanted emissions in the spurious domain".
- [6] Recommendation ITU-T O.153 (10-1992): "Basic parameters for the measurement of error performance at bit rates below the primary rate".
- [7] IEC 60068-2-1 (2007): "Environmental testing - Part 2-1: Tests - Test A: Cold".
- [8] IEC 60068-2-2 (2007): "Environmental testing - Part 2-2: Tests - Test B: Dry heat".
- [9] IEC 60068-2-6 (2007): "Environmental testing - Part 2-6: Tests - Test Fc: Vibration (sinusoidal)".
- [10] ETSI EN 301 908 -14 (V6.2.1) (10-2013): "IMT cellular networks; Harmonized EN covering the essential requirements of article 3.2 of the R&TTE Directive; Part 14: Evolved Universal Terrestrial Radio Access (E-UTRA) Base Stations (BS)".
- [11] ETSI TS 136 141 (V11.9.0) (07-2014): "LTE; Evolved Universal Terrestrial Radio Access (E-UTRA); Base Station (BS) conformance testing (3GPP TS 36.141 version 11.9.0 Release 11)".
- [12] ETSI TS 125 104 (V11.9.0) (07-2014): "Universal Mobile Telecommunications System (UMTS); Base Station (BS) radio transmission and reception (FDD) (3GPP TS 25.104 version 11.9.0 Release 11)".
- [13] Directive 2014/53/EU of the European Parliament and of the Council of 16 April 2014 on the harmonisation of the laws of the Member States relating to the making available on the market of radio equipment and repealing Directive 1999/5/EC (RE Directive).
- [14] Void.

- [15] ETSI TS 136 104 (V10.10.0) (04-2013): "LTE; Evolved Universal Terrestrial Radio Access (E-UTRA); Base Station (BS) radio transmission and reception (3GPP TS 36.104 version 10.10.0 Release 10)".
- [16] ETSI EN 301 908-18 (V6.2.1) (11-2012): "IMT cellular networks; Harmonized EN covering the essential requirements of article 3.2 of the R&TTE Directive; Part 18: E-UTRA, UTRA and GSM/EDGE Multi-Standard Radio (MSR) Base Station (BS)".

2.2 Informative references

References are either specific (identified by date of publication and/or edition number or version number) or non-specific. For specific references, only the cited version applies. For non-specific references, the latest version of the referenced document (including any amendments) applies.

NOTE: While any hyperlinks included in this clause were valid at the time of publication, ETSI cannot guarantee their long term validity.

The following referenced documents are not necessary for the application of the present document but they assist the user with regard to a particular subject area.

- [i.1] ETSI TR 100 028 (all parts): "Electromagnetic compatibility and Radio spectrum Matters (ERM); Uncertainties in the measurement of mobile radio equipment characteristics".
- [i.2] Void.
- [i.3] ETSI EG 201 399: "Electromagnetic compatibility and Radio spectrum Matters (ERM); A guide to the production of Harmonized Standards for application under the Radio & Telecommunication Terminal Equipment Directive 1999/5/EC (R&TTE) and a first guide on the impact of the Radio Equipment Directive 2014/53/EU (RED) on Harmonized Standards".
- [i.4] ETSI TR 102 215: "Electromagnetic compatibility and Radio spectrum Matters (ERM); Recommended approach, and possible limits for measurement uncertainty for the measurement of radiated electromagnetic fields above 1 GHz".
- [i.5] Void.
- [i.6] Void.
- [i.7] IEC 60721-3-3 (2002): "Classification of environmental conditions - Part 3-3: Classification of groups of environmental parameters and their severities - Stationary use at weatherprotected locations".
- [i.8] IEC 60721-3-4 (1995): "Classification of environmental conditions - Part 3: Classification of groups of environmental parameters and their severities - Section 4: Stationary use at non-weather protected locations".
- [i.9] Commission Implementing Decision C(2015) 5376 final of 4.8.2015 on a standardisation request to the European Committee for Electrotechnical Standardisation and to the European Telecommunications Standards Institute as regards radio equipment in support of Directive 2014/53/EU of the European Parliament and of the Council.

3 Definitions, symbols and abbreviations

3.1 Definitions

For the purposes of the present document, the terms and definitions given in the Directive 2014/53/EU [13] and the following apply:

ancillary equipment: equipment (apparatus) used in connection with a CGC, which is considered as ancillary equipment (apparatus) if:

- the equipment is intended for use in conjunction with an CGC to provide additional operational and/or control features to the radio equipment, (e.g. to extend control to another position or location);

- the equipment cannot be used on a stand alone basis to provide user functions independently of an CGC; and
- the CGC to which it is connected is capable of providing some intended operation such as transmitting and/or receiving without the ancillary equipment (i.e. it is not a sub-unit of the main equipment essential to the main equipment basic functions).

aeronautical CGC: ground-based infrastructure at fixed locations used to enhance satellite coverage in zones where communications between the aircraft and one or several space stations cannot be ensured with the required quality. Aeronautical CGC has the antenna system up-tilted for communications with a terminal mounted on an aircraft (below the fuselage)

channel multiplex: set of one or several RF carriers forming one coherent signal

Complementary Ground Component (CGC): ground-based infrastructure at fixed locations used to enhance satellite coverage in zones where communications with one or several space stations cannot be ensured with the required quality

conventional CGC: CGC system where the antenna system is similar to cellular base station for communications with a UE located on the ground

conventional CGC class: wide coverage CGC, medium coverage CGC or local coverage CGC, as declared by the manufacturer

environmental profile: range of environmental conditions under which equipment, within the scope of the present document, is required to comply with the provisions of the present document

local coverage CGC: CGC characterized by requirements derived from picocell scenarios with a CGC to UE minimum coupling loss equal to 45 dB

maximum output power: mean power level per carrier of the CGC measured at the antenna connector in a specified reference condition

mean power: average power (transmitted or received) supplied to the antenna port during an interval of time sufficiently long compared with the lowest frequency encountered in the modulation taken under normal operating conditions

medium coverage CGC: CGC characterized by requirements derived from microcell scenarios with a CGC to UE minimum coupling loss equal to 53 dB

output power: mean power of one carrier of the CGC, delivered to a load with resistance equal to the nominal load impedance of the transmitter

rated output power: rated output power of the CGC is the mean power level per carrier that the manufacturer has declared to be available at the antenna connector

wide coverage CGC: CGC characterized by requirements derived from macrocell scenarios with a CGC to UE minimum coupling loss equal to 70 dB

NOTE: The coupling loss is defined as the space loss that will depend on the propagation channel: Line of Sight, Urban, Suburban, etc.

3.2 Symbols

For the purposes of the present document, the following symbols apply:

α	roll-off factor of the transmitter filter
CB_w	Channel multiplex bandwidth (multiplex spacing)
$CB_{w_{assigned}}$	Assigned channel multiplex bandwidth (multiplex spacing)
$CB_{w_{adjacent}}$	Adjacent channel multiplex bandwidth (multiplex spacing)
F_{uw}	Frequency of unwanted signal

NOTE: This is specified in bracket in terms of an absolute frequency(s) or a frequency offset from the assigned channel frequency.

Ω	Ohm
----------	-----

3.3 Abbreviations

For the purposes of the present document, the following abbreviations apply:

ACLR	Adjacent Channel Leakage power Ratio
ACS	Adjacent Channel Selectivity
ATT	Attenuator
AWGN	Additive White Gaussian Noise
BC	Base Station Controller
BER	Bit Error Ratio
B_{RFBW}	Bottom RFBW
BS	Base Station
BTS	Base Transceiver Station
BW	Bandwidth
CDMA	Code Division Multiple Access
CGC	Complementary Ground Component
CW	Continuous Wave (unmodulated signal)
DC	Direct Current
DUT	Device Under Test
EARFCN	E-UTRA Absolute Radio Frequency Channel Number
EC	European Commission
ECC	Electronic Communications Committee
EFTA	European Free Trade Association
EU	European Union
EUT	Equipment Under Test
EUTRA	Evolved UMTS Terrestrial Radio Access
FDD	Frequency Division Duplexing
FRC	Fixed Reference Channel
GMSK	Gaussian Minimum Shift Keying
GSM	Global System for Mobile communications
IEC	International Electrotechnical Commission
ITU-R	International Telecommunication Union Radiocommunication Sector
ITU-T	International Telecommunication Union Telecommunication Standardization Sector
M_{RFBW}	Middle RFBW
MS	Mobile Station
MSR	Multi-Standard Radio
MSS	Mobile Satellite Service
QAM	Quadrature Amplitude Modulation
QPSK	Quadrature Phase Shift Keying
R&TTE	Radio and Telecommunications Terminal Equipment
RB	Resource Block
RE	Radio Equipment
RF	Radio Frequency
RFBW	Radio Frequency Bandwidth
RMS	Root Mean Square
RRC	Root-Raised Cosine
Rx	Receiver
TDD	Time Division Duplexing
TM	Test Model
T_{RFBW}	Top RFBW
Tx	Transmitter
UE	User Equipment
UMTS	Universal Mobile Telecommunications System
UTRA	Universal Terrestrial Radio Access
WCDMA	Wideband Code Division Multiple Access

4 Technical requirements specifications for conventional CGC

4.1 Environmental profile

The technical requirements of the present document apply under the environmental profile for operation of the equipment, which shall be declared by the supplier. The equipment shall comply with all the technical requirements of the present document at all times when operating within the boundary limits of the declared operational environmental profile.

For guidance on how a supplier can declare the environmental profile, see annex C.

4.2 Conformance requirements

4.2.1 Introduction

The requirements in clause 4 are based on the assumption that the operating band is shared between systems of the IMT-2000 satellite family or systems having compatible characteristics.

The requirements in this clause apply to conventional CGCs only.

To meet the essential requirements under article 3.2 of the RE Directive [13] for IMT-2000 Complementary Ground Component (CGC) seven essential parameters have been identified. Table 2 provides a cross reference between these seven essential parameters and the corresponding nine technical requirements for equipment within the scope of the present document.

Table 2: Cross-references

Essential parameter	Corresponding technical requirements (clause)
Spectrum emissions mask	4.2.2 Spectrum emission mask
	4.2.3 Adjacent channel leakage power ratio (ACLR)
Conducted spurious emissions from the transmitter antenna connector	4.2.4 Transmitter spurious emissions
Accuracy of maximum output power	4.2.5 CGC maximum output power
Intermodulation attenuation of the transmitter	4.2.6 Transmit inter modulation
Conducted spurious emissions from the receiver antenna connector	4.2.7 Receiver spurious emissions
Impact of interference on receiver performance	4.2.8 Blocking characteristics
	4.2.9 Receiver inter-modulation characteristics
Receiver adjacent channel selectivity	4.2.10 Receiver adjacent selectivity

The supplier shall declare the CGC class and operating band(s) for the CGC. The technical requirements apply for the declared CGC class and operating band(s) as outlined for each requirement. For a CGC supporting more than one operating band, conformance testing for each technical requirement in clause 6 shall be performed for each operating band.

The technical requirements also apply to the CGC configurations described in annex C.

4.2.2 Spectrum emission mask

4.2.2.1 Definition

Out-of-band emissions are unwanted emissions immediately outside the channel bandwidth resulting from the modulation process and non-linearity in the transmitter but excluding spurious emissions. This out-of-band emission limit is specified in terms of a spectrum emission mask and adjacent channel leakage power ratio for the transmitter.

4.2.2.2 Limits

The requirement shall be met by a CGC transmitting on a channel multiplex configured in accordance with the manufacturer's specification. Emissions shall not exceed the maximum level specified in tables 3 to 6 for the appropriate CGC maximum output power, in the frequency range from $\Delta f = 0,5 \text{ CBw}$ to Δf_{max} from the carrier frequency, where:

- Δf is the separation between the carrier frequency and the nominal -3 dB point of the measuring filter closest to the carrier frequency.
- f_{offset} is the separation between the carrier frequency and the centre of the measurement filter.
- $f_{\text{offset}_{\text{max}}}$ is either $(10+\text{CBw}/2)$ MHz or the offset to the MSS Tx band edge, whichever is the greater.
- Δf_{max} is equal to $f_{\text{offset}_{\text{max}}}$ minus half of the bandwidth of the measuring filter.
- In tables 3, 4, 5, 6, f_{offset} and CBw are in MHz.

Table 3: Spectrum emission mask values, CGC for output power $P \geq 43 \text{ dBm}$

Frequency offset of measurement filter -3 dB point, Δf	Frequency offset of measurement filter centre frequency, f_{offset}	Maximum level	Measurement bandwidth
$\frac{\text{CBw}}{2} \leq \Delta f < \frac{\text{CBw}}{2} + 200\text{kHz}$	$\frac{\text{CBw}}{2} + 15\text{kHz} \leq f_{\text{offset}} < \frac{\text{CBw}}{2} + 215\text{kHz}$	-12,5 dBm	30 kHz
$\frac{\text{CBw}}{2} + 200\text{kHz} \leq \Delta f < \frac{\text{CBw}}{2} + 1\text{MHz}$	$\frac{\text{CBw}}{2} + 215\text{kHz} \leq f_{\text{offset}} < \frac{\text{CBw}}{2} + 1,015\text{MHz}$	$-12,5\text{dBm} - 15 \times \left[f_{\text{offset}} - \left(\frac{\text{CBw}}{2} + 0,215 \right) \right] \text{dB}$	30 kHz
$\frac{\text{CBw}}{2} + 1\text{MHz} \leq \Delta f < \frac{\text{CBw}}{2} + 1,5\text{MHz}$	$\frac{\text{CBw}}{2} + 1,015\text{MHz} \leq f_{\text{offset}} < \frac{\text{CBw}}{2} + 1,5\text{MHz}$	-24,5 dBm	30 kHz
$\frac{\text{CBw}}{2} + 1,5\text{MHz} \leq \Delta f < \Delta f_{\text{max}}$	$\frac{\text{CBw}}{2} + 1,5\text{MHz} \leq f_{\text{offset}} < f_{\text{offset}_{\text{max}}}$	-11,5 dBm	1 MHz

Table 4: Spectrum emission mask values, CGC maximum output power $39 \text{ dBm} \leq P < 43 \text{ dBm}$

Frequency offset of measurement filter -3 dB point, Δf	Frequency offset of measurement filter centre frequency, f_{offset}	Maximum level	Measurement bandwidth
$\frac{\text{CBw}}{2} \leq \Delta f < \frac{\text{CBw}}{2} + 200\text{kHz}$	$\frac{\text{CBw}}{2} + 15\text{kHz} \leq f_{\text{offset}} < \frac{\text{CBw}}{2} + 215\text{kHz}$	-12,5 dBm	30 kHz
$\frac{\text{CBw}}{2} + 200\text{kHz} \leq \Delta f < \frac{\text{CBw}}{2} + 1\text{MHz}$	$\frac{\text{CBw}}{2} + 215\text{kHz} \leq f_{\text{offset}} < \frac{\text{CBw}}{2} + 1,015\text{MHz}$	$-12,5\text{dBm} - 15 \times \left[f_{\text{offset}} - \left(\frac{\text{CBw}}{2} + 0,215 \right) \right] \text{dB}$	30 kHz
$\frac{\text{CBw}}{2} + 1\text{MHz} \leq \Delta f < \frac{\text{CBw}}{2} + 1,5\text{MHz}$	$\frac{\text{CBw}}{2} + 1,015\text{MHz} \leq f_{\text{offset}} < \frac{\text{CBw}}{2} + 1,5\text{MHz}$	-24,5 dBm	30 kHz
$\frac{\text{CBw}}{2} + 1,5\text{MHz} \leq \Delta f < \frac{\text{CBw}}{2} + 5\text{MHz}$	$\frac{\text{CBw}}{2} + 1,5\text{MHz} \leq f_{\text{offset}} < \frac{\text{CBw}}{2} + 5,5\text{MHz}$	-11,5 dBm	1 MHz
$\frac{\text{CBw}}{2} + 5\text{MHz} \leq \Delta f < \Delta f_{\text{max}}$	$\frac{\text{CBw}}{2} + 5,5\text{MHz} \leq f_{\text{offset}} < f_{\text{offset}_{\text{max}}}$	$P - 54,5 \text{ dB}$	1 MHz

Table 5: Spectrum emission mask values, CGC maximum output power $31 \text{ dBm} \leq P < 39 \text{ dBm}$

Frequency offset of measurement filter -3 dB point, Δf	Frequency offset of measurement filter centre frequency, f_{offset}	Maximum level	Measurement bandwidth
$\frac{\text{CBw}}{2} \leq \Delta f < \frac{\text{CBw}}{2} + 200\text{kHz}$	$\frac{\text{CBw}}{2} + 15\text{kHz} \leq f_{\text{offset}} < \frac{\text{CBw}}{2} + 215\text{kHz}$	P - 51,5 dB	30 kHz
$\frac{\text{CBw}}{2} + 200\text{kHz} \leq \Delta f < \frac{\text{CBw}}{2} + 1\text{MHz}$	$\frac{\text{CBw}}{2} + 215\text{kHz} \leq f_{\text{offset}} < \frac{\text{CBw}}{2} + 1,015\text{MHz}$	$P - 51,5\text{dB} - 15 \times \left[f_{\text{offset}} - \left(\frac{\text{CBw}}{2} + 0,215 \right) \right]$ dB	30 kHz
$\frac{\text{CBw}}{2} + 1 \text{ MHz} \leq \Delta f < \frac{\text{CBw}}{2} + 1,5\text{MHz}$	$\frac{\text{CBw}}{2} + 1,015\text{MHz} \leq f_{\text{offset}} < \frac{\text{CBw}}{2} + 1,5 \text{ MHz}$	P - 63,5 dB	30 kHz
$\frac{\text{CBw}}{2} + 1,5\text{MHz} \leq \Delta f < \frac{\text{CBw}}{2} + 5\text{MHz}$	$\frac{\text{CBw}}{2} + 1,5 \text{ MHz} \leq f_{\text{offset}} < \frac{\text{CBw}}{2} + 5,5 \text{ MHz}$	P - 50,5 dB	1 MHz
$\frac{\text{CBw}}{2} + 5 \text{ MHz} \leq \Delta f < \Delta f_{\text{max}}$	$\frac{\text{CBw}}{2} + 5,5\text{MHz} \leq f_{\text{offset}} < f_{\text{offset}_{\text{max}}}$	P - 54,5 dB	1 MHz

Table 6: Spectrum emission mask values, CGC maximum output power $P < 31 \text{ dBm}$

Frequency offset of measurement filter -3 dB point, Δf	Frequency offset of measurement filter centre frequency, f_{offset}	Maximum level	Measurement bandwidth
$\frac{\text{CBw}}{2} \leq \Delta f < \frac{\text{CBw}}{2} + 200\text{kHz}$	$\frac{\text{CBw}}{2} + 15\text{kHz} \leq f_{\text{offset}} < \frac{\text{CBw}}{2} + 215\text{kHz}$	-20,5 dBm	30 kHz
$\frac{\text{CBw}}{2} + 200\text{kHz} \leq \Delta f < \frac{\text{CBw}}{2} + 1\text{MHz}$	$\frac{\text{CBw}}{2} + 215\text{kHz} \leq f_{\text{offset}} < \frac{\text{CBw}}{2} + 1,015\text{MHz}$	$-20,5 \text{ dBm} - 15 \times \left[f_{\text{offset}} - \left(\frac{\text{CBw}}{2} + 0,215 \right) \right]$	30 kHz
$\frac{\text{CBw}}{2} + 1 \text{ MHz} \leq \Delta f < \frac{\text{CBw}}{2} + 1,5\text{MHz}$	$\frac{\text{CBw}}{2} + 1,015\text{MHz} \leq f_{\text{offset}} < \frac{\text{CBw}}{2} + 1,5 \text{ MHz}$	-32,5 dBm	30 kHz
$\frac{\text{CBw}}{2} + 1,5\text{MHz} \leq \Delta f < \frac{\text{CBw}}{2} + 5\text{MHz}$	$\frac{\text{CBw}}{2} + 1,5 \text{ MHz} \leq f_{\text{offset}} < \frac{\text{CBw}}{2} + 5,5 \text{ MHz}$	-19,5 dBm	1 MHz
$\frac{\text{CBw}}{2} + 5 \text{ MHz} \leq \Delta f < \Delta f_{\text{max}}$	$\frac{\text{CBw}}{2} + 5,5\text{MHz} \leq f_{\text{offset}} < f_{\text{offset}_{\text{max}}}$	-23,5 dBm	1 MHz

4.2.2.3 Conformance

Conformance tests described in clause 5.3.1 shall be carried out.

4.2.3 Adjacent channel leakage power ratio (ACLR)

4.2.3.1 Definition

Adjacent Channel Leakage power Ratio (ACLR) is the ratio of the filtered mean power centred on the assigned channel frequency to the filtered mean power centred on an adjacent channel frequency not belonging to the same channel multiplex.

4.2.3.2 Limits

The limits to ACLR are measured at frequency offsets which are determined by both the assigned multiplex channel bandwidth $\text{CBw}_{\text{assigned}}$ and the adjacent channel bandwidth $\text{CBw}_{\text{adjacent}}$.

In fact, it is necessary to distinguish two cases:

- Case 1: adjacent channel bandwidth is the same as the assigned channel bandwidth: $\text{CBw}_{\text{assigned}} = \text{CBw}_{\text{adjacent}} = \text{CBw}$. In this case, the limits for ACLR shall be as specified in table 7.
- Case 2: adjacent channel bandwidth is different $\text{CBw}_{\text{assigned}} \neq \text{CBw}_{\text{adjacent}}$. In this case, the limits for ACLR shall be as specified in table 8.

Table 7: CGC ACLR limits for Case 1

CGC channel offset below the first or above the last carrier frequency used	Minimum ACLR requirement
CBw	45 dB
2 × CBw	50 dB
> 2 × CBw	50 dB

Table 8: CGC ACLR limits for Case 2

CGC channel offset below the first or above the last carrier frequency used	Minimum ACLR requirement
1 st adjacent channel centre	45 dB
2 nd adjacent channel centre	50 dB
3 rd adjacent channel centre	50 dB
NOTE: If necessary, the channel offset may be increased by including any operational guard band that is defined.	

4.2.3.3 Conformance

Conformance tests described in clause 5.3.2 shall be carried out.

4.2.4 Transmitter spurious emissions

4.2.4.1 Definition

Spurious emissions are emissions which are caused by unwanted transmitter effects such as harmonics emission, parasitic emission, intermodulation products and frequency conversion products, but exclude out-of-band emissions. This is measured at the CGC RF output port.

The requirements of clause 4.2.4.2 apply at frequencies within the specified frequency ranges, which are more than $(10+CBw/2)$ MHz under the first carrier frequency used or more than $(10+CBw/2)$ MHz above the last carrier frequency used.

The requirements of clause 4.2.4.2 shall apply whatever the type of transmitter considered (single carrier or multi-carrier). It applies for all transmission modes foreseen by the manufacturer's specification.

Unless otherwise stated, all requirements are measured as mean power.

4.2.4.2 Limits

4.2.4.2.1 Spurious emissions

The power of any spurious emission (as defined in clause 4.2.4.1) shall not exceed the limits specified in table 9.

Table 9: CGC mandatory spurious emissions limits

Band	Maximum level	Measurement bandwidth	Note
9 kHz to 150 kHz	-36 dBm	1 kHz	see note 1
150 kHz to 30 MHz	-36 dBm	10 kHz	see note 1
30 MHz to 1 GHz	-36 dBm	100 kHz	see note 1
1 GHz to 2 160 MHz	-30 dBm	1 MHz	see note 1
2 160 MHz to 2 210 MHz	-30 dBm	1 MHz	see note 2
2 210 MHz to 12,75 GHz	-30 dBm	1 MHz	see note 3
NOTE 1: Bandwidth as in Recommendation ITU-R SM.329-12 [5], clause 4.1.			
NOTE 2: Limit based on Recommendation ITU-R SM.329-12 [5], clause 4.3 and annex 7.			
NOTE 3: Bandwidth as in Recommendation ITU-R SM.329-12 [5], clause 4.1. Upper frequency as in Recommendation ITU-R SM.329-12 [5], clause 2.5, table 1.			

4.2.4.2.2 Coexistence with other systems in the same geographical area

These requirements shall be applied for the protection of UE, MS and/or BS/CGC operating in other frequency bands in the same geographical area. The requirements may apply in geographic areas where a system operating in another frequency band than the MSS operating band is deployed. The system operating in the other frequency band may be GSM900, DCS1800, PCS1900, GSM850. The power of any spurious emission shall not exceed the limit specified in table 10.

Table 10: Spurious emissions limits in geographic coverage area of systems operating in other frequency bands for protection of receiver

System type operating in the same geographical area	Band for co-existence requirement	Maximum Level	Measurement Bandwidth
GSM900	921 MHz to 960 MHz	-57 dBm	100 kHz
	876 MHz to 915 MHz	-61 dBm	100 kHz
DCS1800	1 805 MHz to 1 880 MHz	-47 dBm	100 kHz
	1 710 MHz to 1 785 MHz	-61 dBm	100 kHz
PCS1900	1 930 MHz to 1 990 MHz	-47 dBm	100 kHz
	1 850 MHz to 1 910 MHz	-61 dBm	100 kHz
GSM850	869 MHz to 894 MHz	-57 dBm	100 kHz
	824 MHz to 849 MHz	-61 dBm	100 kHz

4.2.4.2.3 Protection of UTRA FDD in adjacent frequency band

The power of any spurious emission shall not exceed the limit specified in table 11.

Table 11: Spurious emissions limits for protection of UTRA FDD receiver in adjacent frequency band

System type operating in the same geographical area	Band for co-existence requirement	Maximum Level	Measurement Bandwidth
UTRA FDD	2 110 MHz to 2 170 MHz	-30 dBm	1 MHz

4.2.4.2.4 Protection of UTRA -TDD

The power of any spurious emission shall not exceed the limit specified in table 12.

Table 12: Spurious emissions limits for protection of UTRA TDD receiver

System type operating in the same geographical area	Band for co-existence requirement	Maximum Level	Measurement Bandwidth
UTRA TDD	1 900 MHz to 1 920 MHz	-52 dBm	1 MHz
	2 010 MHz to 2 025 MHz	-52 dBm	1 MHz
	2 570 MHz to 2 610 MHz	-52 dBm	1 MHz

4.2.4.2.5 Protection of UTRA BS

The terms Wide Area BS, Medium Range BS, Local Area BS are defined in ETSI EN 301 908-3 [4].

This requirement may be applied in order to prevent the receivers of other BSs being desensitized by emissions from a CGC transmitter.

The power of any spurious emission may not exceed the limit specified in tables 12a, 12b or 12c depending on the declared Base Station class and operating band.

Table 12a: Spurious emissions limits for protection of a Wide Area BS receiver

Operating band	Band	Maximum level	Measurement bandwidth
I	1 920 MHz to 1 980 MHz	-96 dBm	100 kHz
III	1 710 MHz to 1 785 MHz	-96 dBm	100 kHz
VII	2 500 MHz to 2 570 MHz	-96 dBm	100 kHz
VIII	880 MHz to 915 MHz	-96 dBm	100 kHz

Table 12b: Spurious emissions limits for protection of a Medium Range BS receiver

Operating band	Band	Maximum level	Measurement bandwidth
I	1 920 MHz to 1 980 MHz	-86 dBm	100 kHz
III	1 710 MHz to 1 785 MHz	-86 dBm	100 kHz
VII	2 500 MHz to 2 570 MHz	-86 dBm	100 kHz
VIII	880 MHz to 915 MHz	-86 dBm	100 kHz

Table 12c: Spurious emissions limits for protection of a Local Area BS receiver

Operating band	Band	Maximum level	Measurement bandwidth
I	1 920 MHz to 1 980 MHz	-82 dBm	100 kHz
III	1 710 MHz to 1 785 MHz	-82 dBm	100 kHz
VII	2 500 MHz to 2 570 MHz	-82 dBm	100 kHz
VIII	880 MHz to 915 MHz	-82 dBm	100 kHz

4.2.4.2.6 Protection of the CGC receiver of own or different CGC

This requirement shall be applied in order to prevent the receivers of the CGCs being desensitized by emissions from a CGC transmitter.

The power of any spurious emission (as defined in clause 4.2.4.1) shall not exceed the limits specified in table 13 depending on the declared CGC class.

Table 13: Spurious emissions limits for protection of a CGC receiver

CGC type	Band	Maximum level	Measurement bandwidth
Wide coverage CGC	1 980 MHz to 2 010 MHz	-96 dBm	100 kHz
Medium coverage CGC	1 980 MHz to 2 010 MHz	-86 dBm	100 kHz
Local coverage CGC	1 980 MHz to 2 010 MHz	-82 dBm	100 kHz

4.2.4.3 Conformance

Conformance tests described in clause 5.3.3 shall be carried out.

4.2.5 CGC maximum output power

4.2.5.1 Definition

Maximum output power, P_{max} , of the CGC is the mean power level per carrier measured at the antenna connector in specified reference conditions.

4.2.5.2 Limit

In normal conditions, the CGC maximum output power shall remain within +2,7 dB and -2,7 dB of the manufacturer's rated output power.

In extreme conditions, the CGC maximum output power shall remain within +3,2 dB and -3,2 dB of the manufacturer's rated output power.

4.2.5.3 Conformance

Conformance tests described in clause 5.3.4 shall be carried out.

4.2.6 Transmit inter modulation

4.2.6.1 Definition

The transmit inter modulation performance is a measure of the capability of the transmitter to inhibit the generation of signals in its non-linear elements caused by presence of the wanted signal and an interfering signal reaching the transmitter via the antenna.

The frequency of the interference signal shall be $\pm CBw$, $\pm 2 \times CBw$ and $\pm 3 \times CBw$ offset from the subject signal carrier frequency, but excluding interference frequencies that are outside of the allocated frequency band specified in clause 1.

The requirements are applicable for a channel multiplex.

4.2.6.2 Limit

In the frequency range relevant for this test, the transmit inter-modulation level shall not exceed the Out-of-band emission or the spurious emission requirements of clauses 4.2.2.2, 4.2.3.3 and 4.2.4.2 in the presence of an interference signal with a mean power level 30 dB lower than the mean power of the wanted signal.

4.2.6.3 Conformance

Conformance tests described in clause 5.3.5 shall be carried out.

4.2.7 Receiver spurious emissions

4.2.7.1 Definition

The spurious emission power is the power of the emissions generated or amplified in a receiver that appears at the CGC antenna connector. The requirements apply to all CGC with separate Rx and Tx antenna ports. The test shall be performed when both Tx and Rx are active with the Tx port terminated.

For all CGC with common Rx and Tx antenna port, the transmitter spurious emission as specified in clause 4.2.4 shall apply.

4.2.7.2 Limits

The power of any spurious emission (as defined in clause 4.2.7.1) shall not exceed the limits specified in table 14.

Table 14: Spurious emission requirement

Band	Maximum level	Measurement bandwidth	Note
30 MHz to 1 GHz	-57 dBm	100 kHz	With the exception of frequencies between $(10+CBw/2)$ MHz below the first carrier frequency and $(10+CBw/2)$ MHz above the last carrier frequency used by the CGC transmitter
1 GHz to 12,75 GHz	-47 dBm	1 MHz	
1 900 MHz to 1 980 MHz and 2 010 MHz to 2 025 MHz	-78 dBm	3,84 MHz	Frequency band for UTRA FDD and TDD BS receivers
1 980 MHz to 2 010 MHz	-78 dBm	CBw	frequency allocation as defined in table 1

4.2.7.3 Conformance

Conformance tests described in clause 5.3.6 shall be carried out.

4.2.8 Blocking characteristics

4.2.8.1 Definition

The blocking characteristics are a measure of the receiver ability to receive a wanted signal at its assigned channel frequency in the presence of an unwanted interferer on frequencies other than those of the adjacent channels

4.2.8.2 Limit

The BER shall not exceed 0,001 for the parameters specified in table 15 depending on the declared CGC class.

Table 15: Blocking characteristics

CGC type	Centre frequency of interfering signal	Interfering signal mean power	Wanted signal mean power	Minimum offset of interfering signal	Type of interfering signal
Wide coverage CGC	1 980 MHz to 2 010 MHz	-40 dBm	-115 dBm	10 MHz	WCDMA
	1 900 MHz to 1 980 MHz	-40 dBm	-115 dBm	10 MHz	WCDMA
	1 MHz to 1 980 MHz and 2 010 MHz to 12 750 MHz	-15 dBm	-115 dBm		CW carrier
Medium coverage CGC	1 980 MHz to 2 010 MHz	-35 dBm	-105 dBm	10 MHz	WCDMA
	1 900 MHz to 1 980 MHz	-35 dBm	-105 dBm	10 MHz	WCDMA
	1 MHz to 1 980 MHz and 2 010 MHz to 12 750 MHz	-15 dBm	-115 dBm		CW Carrier
Local coverage CGC	1 980 MHz to 2 010 MHz	-30 dBm	-101 dBm	10 MHz	WCDMA
	1 900 MHz to 1 980 MHz	-30 dBm	-101 dBm	10 MHz	WCDMA
	1 MHz to 1 980 MHz and 2 010 MHz to 12 750 MHz	-15 dBm	-115 dBm		CW carrier

NOTE: The characteristics of the WCDMA interference signal are specified in ETSI TS 125 141 [2], annex I.

4.2.8.3 Conformance

Conformance tests described in clause 5.3.7 shall be carried out.

4.2.9 Receiver inter-modulation characteristics

4.2.9.1 Definition

Third and higher order mixing of the two interfering RF signals can produce an interfering signal in the band of the desired channel.

Inter-modulation response rejection is a measure of the capability of the receiver to receive a wanted signal on its assigned channel frequency in the presence of two or more interfering signals which have a specific frequency relationship to the wanted signal.

4.2.9.2 Limit

The BER shall not exceed 0,001 for the parameters specified in tables 16, 17 or 18 depending on the declared CGC class.

Table 16: Interferer signals for Wide Coverage CGC intermodulation performance requirement

Type of signal	Offset	Signal mean power
Wanted signal	-	-115 dBm
CW signal	2 x CBw	-48 dBm
WCDMA signal	2 x CBw	-48 dBm

NOTE: The characteristics of the WCDMA interference signal are specified in ETSI TS 125 141 [2], annex I.

Table 17: Interferer signals for Medium Coverage CGC intermodulation performance requirement

Type of signal	Offset	Signal mean power
Wanted signal	-	-105 dBm
CW signal	2 x CBw	-44 dBm
WCDMA signal	2 x CBw	-44 dBm

NOTE: The characteristics of the WCDMA interference signal are specified in ETSI TS 125 141 [2], annex I.

Table 18: Interferer signals for Local Coverage CGC intermodulation performance requirement

Type of signal	Offset	Signal mean power
Wanted signal	-	-101 dBm
CW signal	2 x CBw	-38 dBm
WCDMA signal	2 x CBw	-38 dBm
NOTE: The characteristics of the WCDMA interference signal are specified in ETSI TS 125 141 [2], annex I.		

4.2.9.3 Conformance

Conformance tests described in clause 5.3.8 shall be carried out.

4.2.10 Receiver adjacent selectivity

4.2.10.1 Definition

Adjacent Channel Selectivity (ACS) is a measure of the receiver's ability to receive a wanted signal at its assigned channel frequency in the presence of an adjacent channel signal at a given frequency offset from the centre frequency of the assigned channel. ACS is the ratio of the receiver filter attenuation on the assigned channel frequency to the receive filter attenuation on the adjacent channel(s).

The interference signal is offset from the wanted signal by the frequency offset F_{uw} which is determined by both the assigned channel bandwidth $CBw_{assigned}$ and the adjacent channel bandwidth $CBw_{adjacent}$.

4.2.10.2 Limit

In case the assigned and the adjacent multiplex are the same bandwidth ($CBw_{assigned} = CBw_{adjacent} = CBw$), the BER shall not exceed 0,001 using the parameters specified in tables 19, 20 or 21 depending on the declared CGC class.

Table 19: Adjacent channel selectivity for Wide Coverage CGC for the same channel characteristic

Parameter	Level	Unit
Reference measurement channel data rate	4,75	kbit/s
Wanted signal mean power	-115	dBm
Interfering signal mean power	-52	dBm
F_{uw} offset (modulated)	$\pm CBw$	MHz

Table 20: Adjacent channel selectivity for Medium Coverage CGC for the same channel characteristic

Parameter	Level	Unit
Reference measurement channel data rate	4,75	Kbit/s
Wanted signal mean power	-105	dBm
Interfering signal mean power	-42	dBm
F_{uw} offset (modulated)	$\pm CBw$	MHz

Table 21: Adjacent channel selectivity for Local Coverage CGC for the same channel characteristic

Parameter	Level	Unit
Reference measurement channel data rate	4,75	Kbit/s
Wanted signal mean power	-101	dBm
Interfering signal mean power	-38	dBm
F_{uw} offset (modulated)	$\pm CBw$	MHz

Else the BER shall not exceed 0,001 using the parameters specified in tables 22, 23 and 24.

Table 22: Adjacent channel selectivity for Wide Coverage CGC for different channel characteristic

Parameter	Level	Unit
Reference measurement channel data rate	4,75	kbit/s
Wanted signal mean power	-115	dBm
Interfering signal mean power	-52	dBm
F _{uw} offset (modulated)	$\pm \left(\frac{CBw_{assigned}}{2} + \frac{CBw_{adjacent}}{2} \right)$	MHz
NOTE: If necessary a guard band may be introduced.		

Table 23: Adjacent channel selectivity for Medium Coverage CGC for different channel characteristic

Parameter	Level	Unit
Reference measurement channel data rate	4,75	Kbit/s
Wanted signal mean power	-105	dBm
Interfering signal mean power	-42	dBm
F _{uw} offset (modulated)	$\pm \left(\frac{CBw_{assigned}}{2} + \frac{CBw_{adjacent}}{2} \right)$	MHz
NOTE: If necessary a guard band may be introduced.		

Table 24: Adjacent channel selectivity for Local Coverage CGC for different channel characteristic

Parameter	Level	Unit
Reference measurement channel data rate	4,75	Kbit/s
Wanted signal mean power	-101	dBm
Interfering signal mean power	-38	dBm
F _{uw} offset (modulated)	$\pm \left(\frac{CBw_{assigned}}{2} + \frac{CBw_{adjacent}}{2} \right)$	MHz
NOTE: If necessary a guard band may be introduced.		

4.2.10.3 Conformance

Conformance tests described in clause 5.3.9 shall be carried out.

5 Testing for compliance with technical requirements for conventional CGC

5.1 Environmental and other conditions for testing

Tests defined in the present document shall be carried out at representative points within the boundary limits of the declared operational environmental profile.

Where technical performance varies subject to environmental conditions, tests shall be carried out under a sufficient variety of environmental conditions (within the boundary limits of the declared operational environmental profile) to give confidence of compliance for the affected technical requirements.

Normally it should be sufficient for all tests to be conducted using normal test conditions except where otherwise stated.

Many tests in the present document are performed with appropriate frequencies in the bottom, middle and top of the operating frequency band of the CGC. These are denoted as RF channels B (bottom), M (middle) and T (top) and are defined as follows:

- RF channel B: the lowest frequency carrier shall be centred on B.
- RF channel M:
 - if the number N of carriers supported is odd, the carrier (N+1)/2 shall be centred on M;

- if the number N of carriers supported is even, the carrier $N/2$ shall be centred on M .
- RF channel T : the highest frequency carrier shall be centred on T .

The measurement system required for each test is described in annex D.

The applicant shall declare the possible values of assigned and adjacent channel bandwidth used by the system. At a minimum, the test cases shall be defined to include all of the declared channel bandwidths. It is assumed that the assigned and adjacent channel bandwidth can respectively fall in the range of 1 MHz to 8 MHz.

5.2 Interpretation of the measurement results

The interpretation of the results recorded in a test report for the measurements described in the present document shall be as follows:

- the measured value related to the corresponding limit will be used to decide whether an equipment meets the requirements of the present document;
- the value of the measurement uncertainty for the measurement of each parameter shall be included in the test report;
- the recorded value of the measurement uncertainty shall be, for each measurement, equal to or lower than the figures in table 25.

For the test methods, according to the present document, the measurement uncertainty figures shall be calculated and shall correspond to an expansion factor (coverage factor) $k = 1,96$ or $k = 2$ (which provide confidence levels of respectively 95 % and 95,45 % in the case where the distributions characterizing the actual measurement uncertainties are normal (Gaussian)). Principles for the calculation of measurement uncertainty are contained in specific ETSI TR 100 028 [i.1] or ETSI TR 102 215 [i.4].

Table 25 is based on this expansion factor.

In all the relevant clauses all Bit Error Ratio (BER) measurements shall be carried out according to the general rules for statistical testing defined in Recommendation ITU-T O.153 [6].

Table 25: Maximum uncertainty of the test system

Parameter	Conditions	Uncertainty
Spectrum emissions mask		±1,5 dB
Adjacent Channel Leakage power Ratio (ACLR)		±0,8 dB
Transmitter spurious emissions	For "Spurious emissions": f ≤ 2,3 GHz 2,3 GHz < f ≤ 4 GHz f > 4 GHz For the co-existence requirements: For protection of the CGC receiver:	±1,5 dB ±2,0 dB ±4,0 dB ±2,0 dB ±3,0 dB
CGC maximum output power		±0,7 dB
Transmit inter-modulation	For spectrum emissions mask: For ACLR For "Spurious emissions": f ≤ 2,3 GHz 2,3 GHz < f ≤ 4 GHz f > 4 GHz For co-existence requirements Interference signal	±2,5 dB ±2,2 dB ±2,5 dB ±2,8 dB ±4,5 dB ±2,8 dB ±1,0 dB
Receiver spurious emissions	For CGC receive bands (-78 dBm) Outside the CGC receive bands: f ≤ 2,3 GHz 2,3 GHz < f ≤ 4 GHz f > 4 GHz	±3,0 dB ±2,0 dB ±2,0 dB ±4,0 dB
Blocking characteristics	For offset < 15 MHz: For offset ≥ 15 MHz and f ≤ 2,3 GHz 2,3 GHz < f ≤ 4 GHz f > 4 GHz	±1,4 dB ±1,1 dB ±1,8 dB ±3,2 dB
Receiver inter-modulation characteristics		±1,3 dB
Receiver Adjacent Channel Selectivity (ACS)		±1,1 dB

NOTE 1: For RF tests it should be noted that the uncertainties in table 25 apply to the test system operating into a nominal 50 Ω load and do not include system effects due to mismatch between the EUT and the test system.

NOTE 2: If the test system for a test is known to have a measurement uncertainty greater than that specified in table 25, this equipment can still be used, provided that an adjustment is made follows:

- any additional uncertainty in the test system over and above that specified in table 25 is used to tighten the test requirements - making the test harder to pass (for some tests, e.g. receiver tests, this may require modification of stimulus signals). This procedure will ensure that a test system not compliant with table 25 does not increase the probability of passing an EUT that would otherwise have failed a test if a test system compliant with table 25 had been used.

5.3 Radio test suites

5.3.1 Spectrum emission mask

5.3.1.1 Initial conditions

Test environment: Normal; see clause C.1.2.

RF channels to be tested: B, M and T; see clause 5.1.

- 1) Set-up the equipment as shown in annex B. As a general rule, the resolution bandwidth of the measuring equipment should be equal to the measurement bandwidth. However, to improve measurement accuracy, sensitivity, efficiency and avoiding e.g. carrier leakage, the resolution bandwidth may be smaller than the measurement bandwidth. When the resolution bandwidth is smaller than the measurement bandwidth, the result should be integrated over the measurement bandwidth in order to obtain the equivalent noise bandwidth of the measurement bandwidth.

- 2) Measurements with an offset from the carrier centre frequency between $0,5 \times \text{CBw} + 15 \text{ kHz}$ and $(0,5 \times \text{CBw} + 1,5 \text{ MHz})$ shall use a 30 kHz measurement bandwidth.
- 3) Measurements with an offset from the carrier centre frequency between $(0,5 \times \text{CBw} + 1,5 \text{ MHz})$ and $(f_{\text{offset}_{\text{max}}} - 500 \text{ kHz})$ shall use a 1 MHz measurement bandwidth.
- 4) Detection mode: true RMS voltage or true average power.

5.3.1.2 Procedures

- 1) Set the CGC to transmit a signal at the manufacturer's specified maximum output power.
- 2) Step the centre frequency of the measurement filter in contiguous steps and measure the emission within the specified frequency ranges with the specified measurement bandwidth and note that the measured value does not exceed the specified value.

The results obtained shall be compared to the limits in clause 4.2.2.2 in order to prove compliance.

5.3.2 Adjacent Channel leakage Power Ratio (ACLR)

5.3.2.1 Initial conditions

The ACLR related tests shall take into account the two frequency bandwidth cases described in clause 4.2.3.

Test environment: Normal; see clause C.1.2.

RF channels to be tested: B, M and T with multiple carriers if supported; see clause 5.1.

- 1) Connect measurement device to the CGC RF output port as shown in annex D.
- 2) The measurement device characteristics shall be:
 - measurement filter bandwidth: defined in clause 4.2.3.1;
 - detection mode: true RMS voltage or true average power.
- 3) Set the CGC to transmit a signal modulated. The mean power at the RF output port shall be the maximum output power as specified by the manufacturer.
- 4) Set carrier frequency within the frequency band supported by CGC. Minimum carrier spacing shall be CBw and maximum carrier spacing shall be specified by manufacturer.

5.3.2.2 Procedure

Measure conformance with ACLR as defined in clause 4.2.3. In multiple carrier case only offset frequencies below the lowest and above the highest carrier frequency used shall be measured.

The results obtained shall be compared to the limits in clause 4.2.3.2 in order to prove compliance.

5.3.3 Transmitter spurious emissions

5.3.3.1 Initial conditions

Test environment: Normal; see clause C.1.2.

RF channels to be tested: B, M and T with multiple carriers if supported; see clause 5.1.

- 1) Connect the CGC antenna connector to a measurement receiver using an attenuator or a directional coupler if necessary.
- 2) Measurements shall use a measurement bandwidth in accordance to the tables in clause 4.2.4.2.
- 3) Detection mode: true RMS voltage or true average power.
- 4) Configure the CGC with transmitters active at their maximum output power.

5.3.3.2 Procedure

- 1) Set the BC to transmit a signal at the manufacturer's specified maximum output power.
- 2) Measure the emission at the specified frequencies with specified measurement bandwidth and note that the measured value does not exceed the specified value.

The results obtained shall be compared to the limits in clause 4.2.4.2 in order to prove compliance.

5.3.4 CGC maximum output power

5.3.4.1 Initial conditions

Test environment: Normal; see clause C.1.2.

RF channels to be tested: B, M and T; see clause 5.1.

In addition, on one channel only, the test shall be performed under extreme power supply as defined in clause C.1.6.

- 1) Connect the power measuring equipment to the CGC RF output port.

5.3.4.2 Procedure

- 1) Set the CGC to transmit a signal modulated with a combination of control and dedicated physical channels specified.
- 2) Measure the mean power at the RF output port.

The results obtained shall be compared to the limits in clause 4.2.5.2 in order to prove compliance.

5.3.5 Transmit intermodulation

5.3.5.1 Initial conditions

Test environment: Normal; see clause C.1.2.

RF channels to be tested: B, M and T; see clause 5.1.

- a) Test set-up in accordance to annex D.

5.3.5.2 Procedures

- 1) Generate the wanted signal at specified maximum CGC output power.
- 2) Generate the interference signal with frequency offset of CBw relative to the wanted signal, but excluding interference frequencies that are outside of the allocated frequency band for MSS downlink specified in the scope of the present document.
- 3) Adjust ATT1 so the level of the modulated interference signal at CGC is 30 dB below the wanted signal.
- 4) Perform the out-of-band emission tests as specified in clauses 5.3.1 and 5.3.2 for all third and fifth order intermodulation products which appear in the frequency ranges defined in clauses 5.3.1 and 5.3.2. The width of the intermodulation products shall be taken into account.
- 5) Perform the spurious emission test as specified in clause 5.3.3 for all third and fifth order intermodulation products which appear in the frequency ranges defined in clause 5.3.3. The width of the intermodulation products shall be taken into account.
- 6) Verify that the emission level does not exceed the required level with the exception of interference signal frequencies.
- 7) Repeat the test for interference frequency off set of -CBw, but excluding interference frequencies that are outside of the allocated frequency band for MSS downlink specified in the scope of the present document.

- 8) Repeat the test for interference frequency off set of $\pm 2 \times \text{CBw}$ and $\pm 3 \times \text{CBw}$, but excluding interference frequencies that are outside of the allocated frequency band for MSS downlink specified in the scope of the present document.

The results obtained shall be compared to the limits in clause 4.2.6.2 in order to prove compliance.

5.3.6 Receiver spurious emissions

5.3.6.1 Initial conditions

Test environment: Normal; see clause C.1.2.

RF channels to be tested: M, with multi-carrier if supported; see clause 5.1.

- 1) Connect a measurement receiver to the CGC antenna connector as shown in annex D.
- 2) Enable the CGC receiver.
- 3) Start CGC transmission at manufacturer's specified maximum output power.

5.3.6.2 Procedure

- 1) Terminate the CGC Tx antenna connector as shown in annex D.
- 2) Set measurement equipment parameters as specified in table 26.
- 3) Measure the spurious emissions over each frequency range described in clause 4.2.7.2.
- 4) Repeat the test using diversity antenna connector if available.

Table 26: Measurement equipment parameters

Measurement bandwidth	as in table 13
Sweep frequency range	30 MHz to 12,75 GHz
Detection	true RMS voltage or true average power

The results obtained shall be compared to the limits in clause 4.2.7.2 in order to prove compliance.

5.3.7 Blocking characteristics

5.3.7.1 Initial conditions

Test environment: Normal; see clause C.1.2.

RF channels to be tested: M; see clause 5.1.

The CGC shall be configured to operate as close to the centre of the operating band as possible.

- 1) Connect signal generator at the assigned channel frequency of the wanted signal and a signal generator to the antenna connector of one Rx port.
- 2) Terminate any other Rx port not under test.
- 3) Transmit a signal from the signal generator to the CGC. The characteristics of the signal shall be set according to the Uplink (from UE to CGC) reference measurement channel. The level of the signal measured at the CGC antenna connector shall be set to the level specified in clause 4.2.8.2.

5.3.7.2 Procedure

- 1) Set the signal generator to produce an interfering signal at a frequency offset F_{uw} from the assigned channel frequency of the wanted signal which is given by:

$$F_{uw} = \pm(n \times 1 \text{ MHz});$$

where n shall be increased in integer steps from $n = 10$ up to such a value that the centre frequency of the interfering signal covers the range from 1 MHz to 12,75 GHz. The interfering signal level measured at the antenna connector shall be set in dependency of its centre frequency, as specified in table 15. The type of the interfering signal is either equivalent to a continuous WCDMA signal with one code of chip frequency 3,84 Mchip/s, filtered by an RRC transmit pulse-shaping filter with roll-off $\alpha = 0,22$, a CW signal or a GMSK, QPSK or 16 QAM modulated signal.

- 2) Measure the BER of the wanted signal at the CGC receiver.
- 3) Interchange the connections of the CGC Rx ports and repeat the measurements according to steps (1) to (2).

NOTE: ETSI TS 125 141 [2], annex C describes the procedure for BER tests taking into account the statistical consequence of frequent repetition of BER measurements within the blocking test. The consequence is: a DUT exactly on the limit may fail due to the statistical nature 2,55 times (mean value) in 12 750 BER measurements using the predefined wrong decision probability of 0,02 %. If the fail cases are ≤ 12 , it is allowed to repeat the fail cases one time before the final verdict.

The results obtained shall be compared to the limits in clause 4.2.8.2 in order to prove compliance.

5.3.8 Receiver intermodulation characteristics

5.3.8.1 Initial conditions

Test environment: Normal; see clause C.1.2.

RF channels to be tested: B, M and T; see clause 5.1.

- 1) Set-up the equipment as shown in annex D.

5.3.8.2 Procedures

- 1) Generate the wanted signal (reference signal) and adjust ATT1 to set the signal level to the CGC under test to the level specified in tables 16, 17 or 18.
- 2) Adjust the signal generators to type of interfering signal and frequency offset from the frequency of the wanted signal, as specified in tables 16, 17 or 18. The type of the interfering signal is a CW signal.
- 3) Adjust the ATT2 and ATT3 to obtain the specified level of interference signal at the CGC input.
- 4) Measure the BER.
- 5) Repeat the test for interference signal frequency offset of $-2 \times \text{CBw}$ and $-4 \times \text{CBw}$.
- 6) Repeat the whole test for the port which was terminated.

The results obtained shall be compared to the limits in clause 4.2.9.2 in order to prove compliance.

5.3.9 Receiver Adjacent Channel Selectivity (ACS)

5.3.9.1 Initial conditions

Test environment: Normal; see clause C.1.2.

RF channels to be tested: B, M and T; see clause 5.1.

- 1) Set-up the equipment as shown in annex D.

5.3.9.2 Procedure

- 1) Generate the wanted signal and adjust the ATT1 to set the input level to the CGC under test to the level specified in tables 19 to 24.
- 2) Set-up the interference signal at the adjacent channel frequency and adjust the ATT2 to obtain the specified level of interference signal at the CGC input defined in tables 19 to 24. Note that the interference signal shall have an ACLR of at least 63 dB in order to eliminate the impact of interference signal adjacent channel leakage power on the ACS measurement.
- 3) Measure the BER.
- 4) Repeat the test for the port, which was terminated.

The results obtained shall be compared to the limits in clause 4.2.10.2 in order to prove compliance.

6 Technical requirements specifications for Aeronautical CGC

6.1 Environmental profile

The technical requirements of the present document apply under the environmental profile for operation of the Aeronautical CGC, which shall be declared by the supplier. The equipment shall comply with all the technical requirements of the present document at all times when operating within the boundary limits of the declared operational environmental profile.

For guidance on how a supplier can declare the environmental profile, see annex C.

6.2 Conformance requirements

6.2.1 Introduction

To meet the essential requirements under article 3.2 of the RE Directive [13] for Aeronautical Complementary Ground Component (CGC) seven essential parameters have been identified. Table 27 provides a cross reference between these seven essential parameters and the corresponding nine technical requirements for equipment within the scope of the present document.

Table 27: Cross-references

Essential parameter	Corresponding technical requirements (clause)
Spectrum emissions mask	6.2.2
	6.2.3
Conducted spurious emissions from the transmitter antenna connector	6.2.4
Accuracy of maximum output power	6.2.5
Intermodulation attenuation of the transmitter	6.2.6
Conducted spurious emissions from the receiver antenna connector	6.2.7
Impact of interference on receiver performance	6.2.8
	6.2.9
Receiver adjacent channel selectivity	6.2.10

The supplier shall declare the Aeronautical CGC operating band(s). The technical requirements apply for the declared CGC operating band(s) as outlined for each requirement. For an Aeronautical CGC supporting more than one operating band, conformance testing for each technical requirement in clause 7 shall be performed for each operating band.

The technical requirements also apply to the Aeronautical CGC configurations described in annex C.

6.2.2 Spectrum emission mask

6.2.2.1 Definition

Out-of-band emissions are unwanted emissions immediately outside the channel bandwidth resulting from the modulation process and non-linearity in the transmitter but excluding spurious emissions. This out-of-band emission limit is specified in terms of a spectrum emission mask and adjacent channel leakage power ratio for the transmitter.

6.2.2.2 Limits

The requirement shall be met by an Aeronautical CGC transmitting on a channel multiplex configured in accordance with the manufacturer's specification. Emissions shall not exceed the maximum level specified in table 28, in the frequency range from $\Delta f = 0,5 \text{ CBw}$ to Δf_{max} from the carrier frequency, where:

- Δf is the separation between the carrier frequency and the nominal -3 dB point of the measuring filter closest to the carrier frequency.
- f_{offset} is the separation between the carrier frequency and the centre of the measurement filter.
- $f_{\text{offset}_{\text{max}}}$ is either $(10+\text{CBw}/2)$ MHz or the offset to the MSS Tx band edge, whichever is the greater.
- Δf_{max} is equal to $f_{\text{offset}_{\text{max}}}$ minus half of the bandwidth of the measuring filter.
- In table 28 offset and CBw are in MHz.

Table 28: Spectrum emission mask values for Aeronautical CGC for 5 MHz, 10 MHz and 15 MHz channel bandwidth

Frequency offset of measurement filter -3 dB point, Δf	Frequency offset of measurement filter centre frequency, f_{offset}	Maximum level	Measurement bandwidth
$\frac{\text{CBw}}{2} \leq \Delta f < \frac{\text{CBw}}{2} + 200\text{kHz}$	$\frac{\text{CBw}}{2} + 15\text{kHz} \leq f_{\text{offset}} < \frac{\text{CBw}}{2} + 215\text{kHz}$	-12,5 dBm	30 kHz
$\frac{\text{CBw}}{2} + 200\text{kHz} \leq \Delta f < \frac{\text{CBw}}{2} + 1\text{MHz}$	$\frac{\text{CBw}}{2} + 215\text{kHz} \leq f_{\text{offset}} < \frac{\text{CBw}}{2} + 1,015\text{MHz}$	$-12,5\text{dBm} - 15 \times \left[f_{\text{offset}} - \left(\frac{\text{CBw}}{2} + 0,215 \right) \right] \text{dB}$	30 kHz
$\frac{\text{CBw}}{2} + 1\text{MHz} \leq \Delta f < \frac{\text{CBw}}{2} + 1,5\text{MHz}$	$\frac{\text{CBw}}{2} + 1,015\text{MHz} \leq f_{\text{offset}} < \frac{\text{CBw}}{2} + 1,5\text{MHz}$	-24,5 dBm	30 kHz
$\frac{\text{CBw}}{2} + 1,5\text{MHz} \leq \Delta f < \Delta f_{\text{max}}$	$\frac{\text{CBw}}{2} + 1,5\text{MHz} \leq f_{\text{offset}} < f_{\text{offset}_{\text{max}}}$	-11,5 dBm	1 MHz

6.2.2.3 Conformance

Conformance tests described in clause 7.3.1 shall be carried out.

6.2.3 Adjacent channel leakage power ratio (ACLR)

6.2.3.1 Definition

Adjacent Channel Leakage power Ratio (ACLR) is the ratio of the filtered mean power centred on the assigned channel frequency to the filtered mean power centred on an adjacent channel frequency not belonging to the same channel multiplex.

6.2.3.2 Limits

The limits to ACLR are measured at frequency offsets which are determined by both the assigned multiplex channel bandwidth $\text{CBw}_{\text{assigned}}$ and the adjacent channel bandwidth $\text{CBw}_{\text{adjacent}}$. Limits in table 29 shall apply.

Table 29: Aeronautical CGC ACLR limits

Channel bandwidth of lowest (highest) carrier transmitted CBw (MHz)	BS adjacent channel centre frequency offset below the lowest or above the highest carrier centre frequency transmitted	Assumed adjacent channel carrier (informative)	Filter on the adjacent channel frequency and corresponding filter bandwidth	ACLR limit
5, 10, 15	CBw	E-UTRA of same BW	Square (BW_{Config})	44,2 dB
	2 x CBw	E-UTRA of same BW	Square (BW_{Config})	44,2 dB
	$CBw/2 + 2,5$ MHz	3,84 Mcps UTRA	RRC (3,84 Mcps)	44,2 dB
	$CBw/2 + 7,5$ MHz	3,84 Mcps UTRA	RRC (3,84 Mcps)	44,2 dB
NOTE 1: CBw and BW_{Config} are the channel bandwidth and transmission bandwidth configuration of the lowest (highest) carrier transmitted on the assigned channel frequency, defined in ETSI EN 301 908-14 [10].				
NOTE 2: The RRC filter shall be equivalent to the transmit pulse shape filter defined in ETSI TS 125 104 [12], with a chip rate as defined in this table.				

6.2.3.3 Conformance

Conformance tests described in clause 7.3.2 shall be carried out.

6.2.4 Transmitter spurious emissions

6.2.4.1 Definition

Spurious emissions are emissions which are caused by unwanted transmitter effects such as harmonics emission, parasitic emission, intermodulation products and frequency conversion products, but exclude out-of-band emissions. This is measured at the Aeronautical CGC RF output port.

The requirements of clause 6.2.4.2 apply at frequencies within the specified frequency ranges, which are more than $(10+CBw/2)$ MHz under the first carrier frequency used or more than $(10+CBw/2)$ MHz above the last carrier frequency used.

The requirements of clause 6.2.4.2 shall apply whatever the type of transmitter considered (single carrier or multi-carrier). It applies for all transmission modes foreseen by the manufacturer's specification.

Unless otherwise stated, all requirements are measured as mean power.

6.2.4.2 Limits

6.2.4.2.1 CGC Spurious emissions

The power of any spurious emission (as defined in clause 6.2.4.1) shall not exceed the limits specified in table 30.

Table 30: Aeronautical CGC spurious emissions limits

Band	Maximum level	Measurement bandwidth	Note
9 kHz to 150 kHz	-36 dBm	1 kHz	see note 1
150 kHz to 30 MHz	-36 dBm	10 kHz	see note 1
30 MHz to 1 GHz	-36 dBm	100 kHz	see note 1
1 GHz to 12,75 GHz	-30 dBm	1 MHz	see note 2
12,75 GHz to 5th harmonic of the upper frequency edge of the downlink operating band	-30 dBm	1 MHz	see notes 2 and 3
NOTE 1: Bandwidth as in Recommendation ITU-R SM.329-12 [5], section 4.1.			
NOTE 2: Bandwidth as in Recommendation ITU-R SM.329-12 [5], section 4.1. Upper frequency as in Recommendation ITU-R SM.329-12 [5], section 2.5 table 1.			
NOTE 3: Applies only for Bands 22, 42 and 43.			

6.2.4.2.2 Coexistence with other systems

These requirements shall be applied for the protection of receiver of other systems. The power of any spurious emission shall not exceed the limit specified in table 31.

Table 31: CGC Spurious emissions limits for protection of other systems

System type operating in the same geographical area	Band for co-existence requirement	Maximum Level	Measurement Bandwidth
GSM900	921 MHz to 960 MHz	-57 dBm	100 kHz
	876 MHz to 915 MHz	-61 dBm	100 kHz
DCS1800	1 805 MHz to 1 880 MHz	-47 dBm	100 kHz
	1 710 MHz to 1 785 MHz	-61 dBm	100 kHz
PCS1900	1 930 MHz to 1 990 MHz	-47 dBm	100 kHz
	1 850 MHz to 1 910 MHz	-61 dBm	100 kHz
GSM850	869 MHz to 894 MHz	-57 dBm	100 kHz
	824 MHz to 849 MHz	-61 dBm	100 kHz
UTRA FDD Band I or E-UTRA Band 1	2 110 MHz to 2 170 MHz	-52 dBm	1 MHz
	1 920 MHz to 1 980 MHz	-49 dBm	1 MHz
UTRA FDD band III, E-UTRA band 3	1 805 MHz to 1 880 MHz	-52 dBm	1 MHz
	1 710 MHz to 1 785 MHz	-49 dBm	1 MHz
UTRA FDD band VII, E-UTRA band 7	2 620 MHz to 2 690 MHz	-52 dBm	1 MHz
	2 500 MHz to 2 570 MHz	-49 dBm	1 MHz
UTRA FDD band VIII, E-UTRA band 8	925 MHz to 960 MHz	-52 dBm	1 MHz
	880 MHz to 915 MHz	-49 dBm	1 MHz
UTRA FDD band XV	2 600 MHz to 2 620 MHz	-52 dBm	1 MHz
	1 900 MHz to 1 920 MHz	-49 dBm	1 MHz
UTRA FDD band XVI	2 585 MHz to 2 600 MHz	-52 dBm	1 MHz
	2 010 MHz to 2 025 MHz	-49 dBm	1 MHz
UTRA FDD band XX, E-UTRA Band 20	791 MHz to 821 MHz	-52 dBm	1 MHz
	832 MHz to 862 MHz	-49 dBm	1 MHz
UTRA FDD band XXII, E-UTRA band 22	3 510 MHz to 3 590 MHz	-52 dBm	1 MHz
	3 410 MHz to 3 490 MHz	-49 dBm	1 MHz
UTRA TDD in band a), E-UTRA band 33	1 900 MHz to 1 920 MHz	-52 dBm	1 MHz
UTRA TDD in band a), E-UTRA band 34	2 010 MHz to 2 025 MHz	-52 dBm	1 MHz
UTRA TDD in band d), E-UTRA band 38	2 570 MHz to 2 620 MHz	-52 dBm	1 MHz
UTRA TDD in band e), E-UTRA band 40	2 300 MHz to 2 400 MHz	-52 dBm	1 MHz
E-UTRA band 42	3 400 MHz to 3 600 MHz	-52 dBm	1 MHz
E-UTRA band 43	3 600 MHz to 3 800 MHz	-52 dBm	1 MHz

NOTE 1: Where the table has two entries for the same or overlapping frequency ranges, both limits shall be applied.
NOTE 2: As set out in the definition in clause 6.2.4.1, the co-existence requirements in this table do not apply for the 10 MHz frequency range immediately outside the downlink operating band (see table 1).

6.2.4.2.3 Protection of BS receiver

The power of any spurious emission shall not exceed the limit specified in table 32 depending on the declared Base Station class.

The terms Wide Area BS, Medium Range BS, Local Area BS and Home BS are defined in ETSI EN 301 908-3 [4].

Table 32: Aeronautical CGC emissions limits for spurious protection of a BS receiver

BS class	Frequency range	Maximum Level	Measurement Bandwidth	Note
Wide Area BS	F_{UL_low} to F_{UL_high}	-96 dBm	100 kHz	
Local Area BS	F_{UL_low} to F_{UL_high}	-88 dBm	100 kHz	
Home BS	F_{UL_low} to F_{UL_high}	-88 dBm	100 kHz	

NOTE: F_{UL_low} and F_{UL_high} are the lowest and highest frequency of the E-UTRA BS uplink operating band respectively.

6.2.4.3 Conformance

Conformance tests described in clause 7.3.3 shall be carried out.

6.2.5 Aeronautical CGC maximum output power

6.2.5.1 Definition

Maximum output power, P_{max} , of the Aeronautical CGC is the mean power level per carrier measured at the antenna connector in specified reference conditions.

6.2.5.2 Limit

In normal conditions, the Aeronautical CGC maximum output power shall remain within +2,7 dB and -2,7 dB of the manufacturer's rated output power.

In extreme conditions, the Aeronautical CGC maximum output power shall remain within +3,2 dB and -3,2 dB of the manufacturer's rated output power.

6.2.5.3 Conformance

Conformance tests described in clause 7.3.4 shall be carried out.

6.2.6 Transmit intermodulation

6.2.6.1 Definition

The transmit inter modulation performance is a measure of the capability of the transmitter to inhibit the generation of signals in its non-linear elements caused by presence of the wanted signal and an interfering signal reaching the transmitter via the antenna.

The frequency of the interference signal shall be $\pm CBw$, $\pm 2 \times CBw$ and $\pm 3 \times CBw$ offset from the subject signal carrier frequency, but excluding interference frequencies that are outside of the allocated frequency band specified in clause 1.

The requirements are applicable for a channel multiplex.

6.2.6.2 Limit

For the Aeronautical CGC, the wanted signal channel bandwidth CBw shall be the maximum channel bandwidth supported by the Ground Station.

In the frequency range relevant for this test, the transmit intermodulation level shall not exceed the unwanted emission requirements of clauses 6.2.2.2, 6.2.3.2 and 6.2.4.2 in the presence of an interfering signal according to table 33.

Table 33: Interfering and wanted signals for the Aero CGC Transmitter intermodulation requirement

Parameter	Value
Wanted signal	Single-carrier or multi-carrier E-UTRA signal(s) of maximum channel bandwidth CBw supported by the base station
Interfering signal type	E-UTRA signal of channel bandwidth 5 MHz
Interfering signal level	Mean power level 30 dB below the mean power of the wanted signal
Interfering signal centre frequency offset from the lower (higher) edge of the wanted signal	$\pm 2,5$ MHz $\pm 7,5$ MHz $\pm 12,5$ MHz
NOTE:	Interfering signal positions that are partially or completely outside of the downlink operating band of the base station are excluded from the requirement, unless the interfering signal positions fall within the frequency range of adjacent downlink operating bands in the same geographical area.

In case that none of the interfering signal positions according to the conditions of table 33 is applicable, a wanted signal channel bandwidth CBw less than the maximum channel bandwidth supported by the base station shall be selected so that at least one applicable interfering signal position according to table 33 is obtained. If the BS does not support any channel bandwidths less than the maximum supported bandwidth, an interfering signal outside or partly outside the downlink operating band shall be used.

The measurements for unwanted emission requirement due to intermodulation can be limited to the frequency ranges of all third and fifth order intermodulation products, excluding the channel bandwidths of the wanted and interfering signals.

6.2.6.3 Conformance

Conformance tests described in clause 7.3.5 shall be carried out.

6.2.7 Receiver spurious emissions

6.2.7.1 Definition

The spurious emission power is the power of the emissions generated or amplified in a receiver that appears at the Aeronautical CGC antenna connector. The requirements apply to all Aeronautical CGC with separate Rx and Tx antenna ports. The test shall be performed when both Tx and Rx are active with the Tx port terminated.

For all Aeronautical CGC with common Rx and Tx antenna port, the transmitter spurious emission as specified in clause 6.2.4 shall apply.

6.2.7.2 Limits

The power of any spurious emission (as defined in clause 6.2.7.1) shall not exceed the limits specified in table 34.

Table 34: Spurious emission requirement

Frequency range	Maximum level	Measurement Bandwidth	Note
30 MHz to 1 GHz	-57 dBm	100 kHz	
1 GHz to 12,75 GHz	-47 dBm	1 MHz	
12,75 GHz to 5th harmonic of the upper frequency edge of the downlink operating band	-47 dBm	1 MHz	Applies only for Bands 22, 42 and 43.
NOTE: The frequency range between $2,5 \times \text{CBw}$ below the first carrier frequency and $2,5 \times \text{CBw}$ above the last carrier frequency transmitted by the BS, where CBw is the channel bandwidth according to ETSI TS 136 141 [11], table 5.6-1, may be excluded from the requirement. However, frequencies that are more than 10 MHz below the lowest frequency of the downlink operating band or more than 10 MHz above the highest frequency of the downlink operating band (see table 1) shall not be excluded from the requirement.			

6.2.7.3 Conformance

Conformance tests described in clause 7.3.6 shall be carried out.

6.2.8 Blocking characteristics

6.2.8.1 Definition

The blocking characteristics are a measure of the receiver ability to receive a wanted signal at its assigned channel frequency in the presence of an unwanted interferer on frequencies other than those of the adjacent channels

6.2.8.2 Limit

The throughput shall be ≥ 95 % of the maximum throughput of the reference measurement channel, with a wanted and an interfering signal coupled to Aeronautical CGC antenna input using the parameters in table 35 and table 36.

Table 35: Blocking characteristics for Aeronautical CGC

Operating Band	Centre Frequency of Interfering Signal (MHz) (see note 1)	Interfering Signal mean power (dBm)	Wanted Signal mean power (dBm) (see note 2)	Interfering signal centre frequency minimum frequency offset from the lower (higher) edge (MHz)	Type of Interfering Signal
Table 1	$(F_{UL_low} - 20)$ to $(F_{UL_high} + 20)$	-43	$P_{REFSENS} + 6$ dB	See table 40	See table 40
	1 to $(F_{UL_low} - 20)$ $(F_{UL_high} + 20)$ to 12 750	-15	$P_{REFSENS} + 6$ dB		CW carrier
NOTE 1: F_{UL_low} and F_{UL_high} are the lowest and highest frequencies of the uplink operating band, as defined in table 1.					
NOTE 2: $P_{REFSENS}$ is -101,5 dBm					

Table 36: Interfering signal for Aeronautical CGC Blocking performance requirement

E-UTRA channel BW of the lowest (highest) carrier received (MHz)	Interfering signal centre frequency minimum offset to the lower (higher) edge (MHz)	Type of interfering signal
5	$\pm 7,5$	5 MHz E-UTRA signal
10	$\pm 7,5$	5 MHz E-UTRA signal
15	$\pm 7,5$	5 MHz E-UTRA signal

6.2.8.3 Conformance

Conformance tests described in clause 7.3.7 shall be carried out.

6.2.9 Receiver intermodulation characteristics

6.2.9.1 Definition

Third and higher order mixing of the two interfering RF signals can produce an interfering signal in the band of the desired channel.

Inter-modulation response rejection is a measure of the capability of the receiver to receive a wanted signal on its assigned channel frequency in the presence of two or more interfering signals which have a specific frequency relationship to the wanted signal.

6.2.9.2 Limit

The throughput shall be ≥ 95 % of the maximum throughput of the reference measurement channel, with a wanted signal at the assigned channel frequency and two interfering signals with the conditions specified in table 37 and table 38 for intermodulation performance and in table 39 for narrowband intermodulation performance. The reference measurement channel for the wanted signal is identified in tables 7.2-1, 7.2-2 or 7.2-3 of ETSI TS 136 141 [11] for each channel bandwidth and further specified in annex A of ETSI TS 136 141 [11].

Table 37: Intermodulation performance requirement for Aeronautical CGC

Wanted signal mean power (dBm)	Interfering signal mean power	Type of interfering signal
$P_{REFSENS} + 6$ dB (see note)	-52 dBm	See table 40
NOTE: $P_{REFSENS}$ is -101,5 dBm This requirement shall apply only for a FRC A1-3 (see ETSI TS 136 141 [11], clause A.1) mapped to the frequency range at the channel edge adjacent to the interfering signals.		

Table 38: Interfering signal for Intermodulation performance requirement for Aeronautical CGC

E-UTRA channel bandwidth of the lowest (highest) carrier received (MHz)	Interfering signal centre frequency offset from the lower (higher) edge (MHz)	Type of interfering signal
5	$\pm 7,5$	CW
	$\pm 17,5$	5 MHz E-UTRA signal
10	$\pm 7,375$	CW
	$\pm 17,5$	5 MHz E-UTRA signal
15	$\pm 7,25$	CW
	$\pm 17,5$	5 MHz E-UTRA signal

Table 39: Narrowband intermodulation performance requirement for Aeronautical CGC

E-UTRA channel bandwidth of the lowest (highest) carrier received (MHz)	Wanted signal mean power (dBm)	Interfering signal mean power (dBm)	Interfering RB centre frequency offset from the lower (higher) edge (kHz)	Type of interfering signal
5	$P_{\text{REFSENS}} + 6$ dB (see note 1)	-52	± 360	CW
		-52	$\pm 1\ 060$	5 MHz E-UTRA signal, 1 RB (see note 2)
10	$P_{\text{REFSENS}} + 6$ dB (see notes 1 and 3)	-52	± 325	CW
		-52	$\pm 1\ 240$	5 MHz E-UTRA signal, 1 RB (see note 2)
15	$P_{\text{REFSENS}} + 6$ dB (see notes 1 and 3)	-52	± 380	CW
		-52	$\pm 1\ 600$	5 MHz E-UTRA signal, 1 RB (see note 2)

NOTE 1: P_{REFSENS} is -101,5 dBm.
NOTE 2: Interfering signal consisting of one resource block positioned at the stated offset, the channel bandwidth of the interfering signal is located adjacently to the channel bandwidth of the lower (higher) edge.
NOTE 3: This requirement shall apply only for an FRC A1-3 (see ETSI TS 136 141 [11], clause A.1) mapped to the frequency range at the channel edge adjacent to the interfering signals.

6.2.9.3 Conformance

Conformance tests described in clause 7.3.8 shall be carried out.

6.2.10 Receiver adjacent Channel selectivity and narrow-band blocking

6.2.10.1 Definition

Adjacent Channel Selectivity (ACS) and narrowband blocking are measures of the receiver's ability to receive a wanted signal at its assigned channel frequency in the presence of an adjacent channel signal at a given frequency offset from the centre frequency of the assigned channel. ACS is the ratio of the receiver filter attenuation on the assigned channel frequency to the receive filter attenuation on the adjacent channel(s).

6.2.10.2 Limit

The throughput shall be ≥ 95 % of the maximum throughput of the reference measurement channel. The wanted and the interfering signal coupled to the Aeronautical CGC antenna input are specified in table 40 and table 41 for narrowband blocking and table 42 for ACS.

Table 40: Narrowband blocking requirement for Aeronautical CGC

Wanted signal mean power (dBm)	Interfering signal mean power	Type of interfering signal
$P_{\text{REFSENS}} + 6$ dB (see note)	-49 dBm	See table 41
NOTE: P_{REFSENS} is -101,5 dBm.		

Table 41: Interfering signal for Narrowband blocking requirement for Aeronautical CGC

E-UTRA channel BW of the lowest (highest) carrier received (MHz)	Interfering RB centre frequency offset to the lower (higher) edge (kHz)	Type of interfering signal
5	$\pm(342,5 + m \times 180)$, $m = 0, 1, 2, 3, 4, 9, 14, 19, 24$	5 MHz E-UTRA signal, 1 RB (see note)
10	$\pm(347,5 + m \times 180)$, $m = 0, 1, 2, 3, 4, 9, 14, 19, 24$	5 MHz E-UTRA signal, 1 RB (see note)
15	$\pm(352,5 + m \times 180)$, $m = 0, 1, 2, 3, 4, 9, 14, 19, 24$	5 MHz E-UTRA signal, 1 RB (see note)
NOTE: Interfering signal consisting of one resource block is positioned at the stated offset, the channel bandwidth of the interfering signal is located adjacently to the lower (higher) edge. Frequency offsets are such that the interfering signal is outside the channel.		

Table 42: Adjacent channel selectivity for Aeronautical CGC

E-UTRA channel bandwidth of the lowest (highest) carrier received (MHz)	Wanted signal mean power (dBm)	Interfering signal mean power (dBm)	Interfering signal centre frequency offset from the lower (higher) edge (MHz)	Type of interfering signal
5	$P_{\text{REFSENS}} + 6 \text{ dB}$ (see note)	-52	$\pm 2,5025$	5 MHz E-UTRA signal
10	$P_{\text{REFSENS}} + 6 \text{ dB}$ (see note)	-52	$\pm 2,5075$	5 MHz E-UTRA signal
15	$P_{\text{REFSENS}} + 6 \text{ dB}$ (see note)	-52	$\pm 2,5125$	5 MHz E-UTRA signal
NOTE: P_{REFSENS} is -101,5 dBm. Frequency offsets are such that the interfering signal is outside the channel.				

6.2.10.3 Conformance

Conformance tests described in clause 7.3.9 shall be carried out.

7 Testing for compliance with technical requirements for Aeronautical CGC

7.1 Environmental and other conditions for testing

Tests defined in the present document shall be carried out at representative points within the boundary limits of the declared operational environmental profile.

Where technical performance varies subject to environmental conditions, tests shall be carried out under a sufficient variety of environmental conditions (within the boundary limits of the declared operational environmental profile) to give confidence of compliance for the affected technical requirements.

Normally it should be sufficient for all tests to be conducted using normal test conditions except where otherwise stated.

For the single carrier testing many tests in the present document are performed with appropriate frequencies in the bottom, middle and top of the operating frequency band of the CGC. These are denoted as RF channels B (bottom), M (middle) and T (top) and are defined as follows:

RF channel B: the lowest frequency carrier shall be centred on B.

RF channel M:

- if the number N of carriers supported is odd, the carrier $(N+1)/2$ shall be centred on M ;
- if the number N of carriers supported is even, the carrier $N/2$ shall be centred on M .

RF channel T : the highest frequency carrier shall be centred on T.

For the non-single carrier testing many tests in the present document are performed with the maximum RF bandwidth position located at the bottom, middle and top of the supported frequency range in each operating band. These are denoted as B_{RFBW} (bottom), M_{RFBW} (middle) and T_{RFBW} (top) for non-aggregated channels and are defined in ETSI TS 136 141 [11], clause 4.7.1.

The measurement system required for each test is described in annex D.

The applicant shall declare the possible values of assigned and adjacent channel bandwidth used by the system. At a minimum, the test cases shall be defined to include all of the declared channel bandwidths.

7.2 Interpretation of the measurement results

The interpretation of the results recorded in a test report for the measurements described in the present document shall be as follows:

- the measured value related to the corresponding limit will be used to decide whether an equipment meets the requirements of the present document;
- the value of the measurement uncertainty for the measurement of each parameter shall be included in the test report;
- the recorded value of the measurement uncertainty shall be, for each measurement, equal to or lower than the figures in table 43.

For the test methods, according to the present document, the measurement uncertainty figures shall be calculated and shall correspond to an expansion factor (coverage factor) $k = 1,96$ or $k = 2$ (which provide confidence levels of respectively 95 % and 95,45 % in the case where the distributions characterizing the actual measurement uncertainties are normal (Gaussian)). Principles for the calculation of measurement uncertainty are contained in specific ETSI TR 100 028 [i.1] or ETSI TR 102 215 [i.4].

Table 43 is based on this expansion factor.

In all the relevant clauses all Bit Error Ratio (BER) measurements shall be carried out according to the general rules for statistical testing defined in Recommendation ITU-T O.153 [6].

Table 43: Maximum uncertainty of the test system

Parameter	Conditions	Uncertainty
Spectrum emissions mask		±1,5 dB
Adjacent Channel Leakage power Ratio (ACLR)		±0,8 dB
Transmitter spurious emissions	For "Spurious emissions": f ≤ 2,3 GHz 2,3 GHz < f ≤ 4 GHz f > 4 GHz For the co-existence requirements: For protection of the CGC receiver:	±1,5 dB ±2,0 dB ±4,0 dB ±2,0 dB ±3,0 dB
CGC maximum output power		±0,7 dB
Transmit inter-modulation	For spectrum emissions mask: For ACLR For "Spurious emissions": f ≤ 2,3 GHz 2,3 GHz < f ≤ 4 GHz f > 4 GHz For co-existence requirements Interference signal	±2,5 dB ±2,2 dB ±2,5 dB ±2,8 dB ±4,5 dB ±2,8 dB ±1,0 dB
Receiver spurious emissions	For CGC receive bands (-78 dBm) Outside the CGC receive bands: f ≤ 2,3 GHz 2,3 GHz < f ≤ 4 GHz f > 4 GHz	±3,0 dB ±2,0 dB ±2,0 dB ±4,0 dB
Blocking characteristics	For offset < 15 MHz: For offset ≥ 15 MHz and f ≤ 2,3 GHz 2,3 GHz < f ≤ 4 GHz f > 4 GHz	±1,4 dB ±1,1 dB ±1,8 dB ±3,2 dB
Receiver inter-modulation characteristics		±1,3 dB
Receiver Adjacent Channel Selectivity (ACS)		±1,1 dB

NOTE 1: For RF tests it should be noted that the uncertainties in table 43 apply to the test system operating into a nominal 50 Ω load and do not include system effects due to mismatch between the EUT and the test system.

NOTE 2: If the test system for a test is known to have a measurement uncertainty greater than that specified in table 43, this equipment can still be used, provided that an adjustment is made follows:

- any additional uncertainty in the test system over and above that specified in table 43 is used to tighten the test requirements - making the test harder to pass (for some tests, e.g. receiver tests, this may require modification of stimulus signals). This procedure will ensure that a test system not compliant with table 43 does not increase the probability of passing an EUT that would otherwise have failed a test if a test system compliant with table 43 had been used.

7.3 Radio test suites

7.3.1 Spectrum emission mask

7.3.1.1 Initial conditions

Test environment: normal, see ETSI TS 136 141 [11], clause D.2.

RF channels to be tested: B, M and T, see clause 7.1.

- Connect the signal analyser to the aeronautical CGC Antenna connector as shown in ETSI TS 136 141 [11], clause I.1.1.

As a general rule, the resolution bandwidth of the measuring equipment should be equal to the measurement bandwidth. However, to improve measurement accuracy, sensitivity, efficiency and avoiding e.g. carrier leakage, the resolution bandwidth may be smaller than the measurement bandwidth. When the resolution bandwidth is smaller than the measurement bandwidth, the result should be integrated over the measurement bandwidth in order to obtain the equivalent noise bandwidth of the measurement bandwidth.

- 2) Detection mode: true RMS.

7.3.1.2 Procedures

- 1) Set the aeronautical CGC transmission at maximum total power (P_{max}) as specified by the supplier. Channel set-up shall be according to E-TM 1.1 in ETSI TS 136 141 [11].
- 2) Step the centre frequency of the measurement filter in contiguous steps and measure the emission within the specified frequency ranges with the specified measurement bandwidth.
- 3) Repeat the test with the channel set-up according to E-TM 1.2 in ETSI TS 136 141 [11].

The results obtained shall be compared to the limits in clause 6.2.2.2 in order to prove compliance.

7.3.2 Adjacent Channel leakage Power Ratio (ACLR)

7.3.2.0 General

The ACLR related tests shall take into account the two frequency bandwidth cases described in clause 6.2.3.

7.3.2.1 Initial conditions

Test environment: normal, see ETSI TS 136 141 [11], clause D.2.

RF channels to be tested: B, M and T; see clause 7.1.

RF bandwidth position to be tested: B_{RFBW} , M_{RFBW} and T_{RFBW} ; see clause 7.1.

- 1) Connect measurement device to the aeronautical CGC Antenna connector as shown in ETSI TS 136 141 [11], clause I.1.1.
- 2) The measurement device characteristics shall be:
 - measurement filter bandwidth: defined in clause 6.2.3.2;
 - detection mode: true RMS voltage or true average power.
- 3) Set the aeronautical CGC to transmit a signal according to E-TM1 in ETSI TS 136 141 [11]. The mean power at the Antenna connector shall be the maximum output power as specified by the manufacturer.
- 4) Set carrier frequency within the frequency band supported by the aeronautical CGC.

7.3.2.2 Procedure

- 1) Measure Adjacent channel leakage power ratio for the frequency offsets both side of channel frequency as specified in table 29. In multiple carrier case only offset frequencies below the lowest and above the highest carrier frequency transmitted shall be measured.
- 2) Repeat the test with the channel set-up according to E-TM1.2 in ETSI TS 136 141 [11].

The results obtained shall be compared to the limits in clause 6.2.3.2 in order to prove compliance.

7.3.3 Transmitter spurious emissions

7.3.3.1 Initial conditions

Test environment: normal, see ETSI TS 136 141 [11], clause D.2.

RF channels to be tested: B, M and T, see clause 7.1.

- 1) Connect the aeronautical CGC antenna connector to a measurement receiver according to ETSI TS 136 141 [11], clause I.1.1 using an attenuator or a directional coupler if necessary.
- 2) Measurements shall use a measurement bandwidth in accordance to the conditions in ETSI TS 136 104 [15], clause 6.6.4.
- 3) Detection mode: true RMS.

Configure the CGC with transmitters active at their maximum output power.

7.3.3.2 Procedure

- 1) Set the CGC to transmit a signal according to E-TM1.1 in ETSI TS 136 141 [11] at the manufacturer's specified maximum output power.
- 2) Measure the emission at the specified frequencies with specified measurement bandwidth and note that the measured value does not exceed the specified value.

The results obtained shall be compared to the limits in clause 6.2.4.2 in order to prove compliance.

7.3.4 Aeronautical CGC maximum output power

7.3.4.1 Initial conditions

Test environment: normal, see ETSI TS 136 141 [11], clause D.2.

RF channels to be tested: B, M and T, see clause 7.1.

RF bandwidth position to be tested: B_{RFBW} , M_{RFBW} and T_{RFBW} ; see clause 7.1.

In addition, on one EARFCN only, the test shall be performed under extreme power supply as defined in ETSI TS 136 141 [11], clause D.5.

NOTE: Tests under extreme power supply also test extreme temperature.

- 1) Connect the power measuring equipment to the aeronautical CGC Antenna connector as shown in ETSI TS 136 141 [11], clause I.1.1.

7.3.4.2 Procedure

- 1) Set the aeronautical CGC to transmit a signal according to E-TM1.1 in ETSI TS 136 141 [11].
- 2) Measure the mean power for each carrier at the Antenna connector.

The results obtained shall be compared to the limits in clause 6.2.5.2 in order to prove compliance.

7.3.5 Transmit intermodulation

7.3.5.1 Initial conditions

Test environment: normal, see ETSI TS 136 141 [11], clause D.2.

RF channels to be tested: B, M and T, see clause 7.1.

RF bandwidth position to be tested: B_{RFBW} , M_{RFBW} and T_{RFBW} ; see clause 7.1.

The wanted signal channel bandwidth CBW shall be the maximum channel bandwidth supported by the Complementary Ground Component.

Connect the signal analyser to the Complementary Ground Component Antenna connector as shown in ETSI TS 136 141 [11], clause I.1.2.

7.3.5.2 Procedures

- 1) Generate the wanted signal according to E-TM1.1 in ETSI TS 136 141 [11] at specified maximum output power, P_{max} .
- 2) Generate the interfering signal according to E-TM1.1 in ETSI TS 136 141 [11], with 5 MHz channel bandwidth and a centre frequency offset according to the conditions of table 33.
- 3) Adjust ATT1 so that level of the E-UTRA modulated interfering signal is as defined in clause 6.2.6.2.
- 4) Perform the unwanted emission tests as specified in clauses 7.3.1 and 7.3.2, for all third and fifth order intermodulation products which appear in the frequency ranges defined in clauses 7.3.1 and 7.3.2. The width of the intermodulation products shall be taken into account.
- 5) Perform the Transmitter spurious emissions test as specified in clause 7.3.3, for all third and fifth order intermodulation products which appear in the frequency ranges defined in clause 7.3.3. The width of the intermodulation products shall be taken into account.
- 6) Verify that the emission level does not exceed the required level with the exception of interfering signal frequencies.
- 7) Repeat the test for the remaining interfering signal centre frequency offsets according to the conditions of table 33.

NOTE: The third order intermodulation products are centred at $2F1 \pm F2$ and $2F2 \pm F1$. The fifth order intermodulation products are centred at $3F1 \pm 2F2$, $3F2 \pm 2F1$, $4F1 \pm F2$, and $4F2 \pm F1$ where $F1$ represents the wanted signal centre frequency and $F2$ represents the interfering signal centre frequency. The width of intermodulation products is:

- $(n \times CBw + m \times 5 \text{ MHz})$ for the $nF1 \pm mF2$ products;
- $(n \times 5 \text{ MHz} + m \times CBw)$ for the $nF2 \pm mF1$ products.

The results obtained shall be compared to the limits in clause 6.2.6.2 in order to prove compliance.

7.3.6 Receiver spurious emissions

7.3.6.1 Initial conditions

Test environment: normal, see ETSI TS 136 141 [11], clause D.2.

RF channels to be tested: M, see clause 7.1.

RF bandwidth position to be tested: M_{RFBW} , see clause 7.1.

- 1) Connect a measurement receiver to the aeronautical CGC antenna connector as shown in ETSI TS 136 141 [11], clause I.2.6.
- 2) Enable the aeronautical CGC receiver.
- 3) Terminate the aeronautical CGC TX antenna connector as shown in ETSI TS 136 141 [11], clause I.2.6.

7.3.6.2 Procedure

- 1) Start aeronautical CGC transmission according to E-TM 1.1 in ETSI TS 136 141 [11] at P_{max} , for multi-carrier operation start aeronautical CGC transmission according to applicable test configuration in ETSI TS 136 141 [11], clause 4.10 with the sum of the carrier powers equals to P_{max} .
- 2) Set measurement equipment parameters as specified in table 34.
- 3) Measure the spurious emissions over each frequency range described in clause 6.2.7.2.
- 4) Repeat the test using diversity antenna connector if available.

The results obtained shall be compared to the limits in clause 6.2.7.2 in order to prove compliance.

7.3.7 Blocking characteristics

7.3.7.1 Initial conditions

Test environment: normal, see ETSI TS 136 141 [11], clause D.2.

RF channels to be tested: M see clause 7.1.

RF bandwidth position to be tested: M_{RFBW} , see clause 7.1.

The BS shall be configured to operate as close to the centre of the operating band (see table 1) as possible.

Channel bandwidths to be tested:

- a) In the frequency range $(F_{UL_low} - 20)$ MHz to $(F_{UL_high} + 20)$ MHz the requirement shall be tested with the lowest and the highest bandwidth supported by the aeronautical CGC.
 - b) In the frequency ranges 1 MHz to $(F_{UL_low} - 20)$ MHz and $(F_{UL_high} + 20)$ MHz to 12 750 MHz the requirement shall be tested only with the lowest bandwidth supported by the aeronautical CGC.
- 1) Connect the signal generator for the wanted signal and the signal generator for the interfering signal to the antenna connector of one RX port according to as shown in ETSI TS 136 141 [11], clause I.2.5.
 - 2) Terminate any other RX port not under test.
 - 3) Start to transmit according to reference measurement channel as shown in ETSI TS 136 141 [11], clause A.1 to the aeronautical CGC under test. The level of the wanted signal measured at the CGC antenna connector shall be set to the level specified in clause 6.2.8.2.

7.3.7.2 Procedure

- 1) For FDD aeronautical CGC start aeronautical CGC transmission according to E-TM 1.1 in ETSI TS 136 141 [11] at P_{max} , for multi-carrier operation start CGC transmission according to applicable test configuration in clause 4.10 of ETSI TS 136 141 [11] with the same carrier locations used for the wanted signal with the sum of the carrier powers equal to P_{max} .

The transmitter may be turned off for the out-of-band blocker tests when the frequency of the blocker is such that no IM2 or IM3 products fall inside the bandwidth of the wanted signal.

- 2) Adjust the signal generators to the type of interfering signals, levels and the frequency offsets as specified in table 35 and table 36. The E-UTRA interfering signal shall be swept with a step size of 1 MHz starting from the minimum offset to the channel edges of the wanted signal as specified in table 36. The CW interfering signal shall be swept with a step size of 1 MHz within the range specified in table 35.
- 3) Measure the throughput of the wanted signal at the CGC receiver according to ETSI TS 136 141 [11], annex E, for multi-carrier operation the throughput shall be measured for relevant carriers specified by the test configuration in ETSI TS 136 141 [11], clause 4.10.
- 4) Interchange the connections of the aeronautical CGC RX ports and repeat the measurements according to steps 1) to 3).

For each measured E-UTRA carrier, the results obtained shall be compared to the limits in clause 6.2.8.2 in order to prove compliance.

7.3.8 Receiver intermodulation characteristics

7.3.8.1 Initial conditions

Test environment: normal, see ETSI TS 136 141 [11], clause D.2.

RF channels to be tested: B, M and T, see clause 7.1.

RF bandwidth position to be tested: B_{RFBW} and T_{RFBW} ; see clause 7.1.

- 1) Set-up the measurement system as shown in ETSI TS 136 141 [11], clause I.2.7.

7.3.8.2 Procedures

- 1) Generate the wanted signal and adjust the signal level to the aeronautical CGC under test to the level specified in table 37.
- 2) Adjust the signal generators to the type of interfering signals, levels and the frequency offsets as specified in table 37 and table 38 for intermodulation requirement, table 39 for narrowband intermodulation requirement.
- 3) Measure the throughput according to ETSI TS 136 141 [11], annex E, for multi-carrier operation the throughput shall be measured for relevant carriers specified by the test configuration in ETSI TS 136 141 [11], clause 4.10.
- 4) Repeat the whole test for the port which was terminated.

For each measured E-UTRA carrier, the results obtained shall be compared to the limits in clause 6.2.9.2 in order to prove compliance.

7.3.9 Receiver Adjacent Channel Selectivity (ACS)

7.3.9.1 Initial conditions

Test environment: normal, see ETSI TS 136 141 [11], clause D.2.

RF channels to be tested: B, M and T, see clause 7.1.

RF bandwidth position to be tested: M_{RFBW} , see clause 7.1.

- 1) Set-up the measurement system as shown in ETSI TS 136 141 [11], clause I.2.4.

7.3.9.2 Procedure for Adjacent Channel Selectivity

- 1) Generate the wanted signal and adjust the input level to the aeronautical CGC under test to the level specified in table 42.
- 2) Set-up the interfering signal at the adjacent channel frequency and adjust the interfering signal level at the aeronautical CGC input to the level defined in table 42.
- 3) Measure the throughput according to ETSI TS 136 141 [11], annex E, for multi-carrier operation the throughput shall be measured for relevant carriers specified by the test configuration in ETSI TS 136 141 [11], clause 4.10.
- 4) Repeat the test for the port, which was terminated.

7.3.9.3 Procedure for narrow-band blocking

- 1) For FDD aeronautical CGC start aeronautical CGC transmission according to E-TM1.1 in ETSI TS 136 141 [11] at P_{max} , for multi-carrier operation start aeronautical CGC transmission according to applicable test configuration in clause 4.10 of ETSI TS 136 141 [11]. with the same carrier locations used for the wanted signal with the sum of the carrier powers equal to P_{max} .
- 2) Generate the wanted signal and adjust the input level to the aeronautical CGC under test to the level specified in table 40.
- 3) Adjust the interfering signal level at the aeronautical CGC input to the level defined in table 40. Set-up and sweep the interfering RB centre frequency offset to the channel edge of the wanted signal according to table 41.
- 4) Measure the throughput according to ETSI TS 136 141 [11], annex E, for multi-carrier operation the throughput shall be measured for relevant carriers specified by the test configuration in ETSI TS 136 141 [11], clause 4.10.
- 5) Repeat the test for the port, which was terminated.

For each measured E-UTRA carrier, the results obtained shall be compared to the limits in clause 6.2.10.2 in order to prove compliance.

8 Technical requirements specifications for conventional CGC E-UTRA

8.1 Environmental profile

The technical requirements of the present document apply under the environmental profile for operation of the equipment, which shall be declared by the supplier. The equipment shall comply with all the technical requirements of the present document at all times when operating within the boundary limits of the declared operational environmental profile.

For guidance on how a supplier can declare the environmental profile, see annex C.

8.2 Conformance requirements

8.2.1 Introduction

To meet the essential requirement under article 3.2 of Directive 2014/53/EU [13] (RE Directive) for E-UTRA Complementary Ground Component (CGC), seven essential parameters in addition to those in ETSI EN 301 908-1 [3] have been identified. Table 44 provides a cross reference between these seven essential parameters and the corresponding eleven technical requirements for equipment within the scope of the present document.

Table 44: Cross references

Essential parameter	Corresponding technical requirements
Spectrum emissions mask	8.2.2 Operating band unwanted emissions
	8.2.3 Adjacent Channel Leakage power Ratio (ACLR)
Conducted spurious emissions from the transmitter antenna connector	8.2.4 Transmitter spurious emissions
Accuracy of maximum output power	8.2.5 CGC maximum output power
Intermodulation attenuation of the transmitter	8.2.6 Transmit intermodulation
Conducted spurious emissions from the receiver antenna connector	8.2.7 Receiver spurious emissions
Impact of interference on receiver performance	8.2.8 Blocking characteristics
	8.2.9 Receiver intermodulation characteristics
Receiver adjacent channel selectivity	8.2.10 Adjacent Channel Selectivity (ACS) and narrow-band blocking

NOTE: There are EC and ECC Decisions for the harmonisation of certain frequency bands for terrestrial systems capable of providing electronic communications services, including technical conditions and parameters related to spectrum usage of the bands. These are related to the deployment and installation of the equipment, but are not related to the conformity of the equipment with the present document.

The manufacturer shall declare the following:

- The operating band(s) supported by the CGC according to table 1.
- The supported RF configurations according to clause 4.6.8 of ETSI TS 136 141 [11].

The technical requirements in the present document apply for CGCs supporting E-UTRA, for the declared CGC class and operating band(s) as outlined for each requirement. For a CGC supporting more than one operating band, conformance testing for each technical requirement in clause 9 shall be performed for each operating band.

When the CGC is configured to receive multiple carriers, all the throughput requirements are applicable for each received carrier. For ACS, blocking and intermodulation characteristics, the negative offsets of the interfering signal apply relative to the lower edge and positive offsets of the interfering signal apply relative to the higher edge.

The technical requirements also apply to the CGC configurations described in annex B.

For an E-UTRA Wide Area CGC additionally conforming to ETSI EN 301 908-18 [16], conformance with the technical requirements listed in table 44 can equally be demonstrated through the corresponding technical requirements and test suites in ETSI EN 301 908-18 [16], as listed in table 45.

When conformance is demonstrated through the test suites in ETSI EN 301 908-18 [16] for these technical requirement, the corresponding test suites in the present document need not be performed.

Table 45: Alternative technical requirements and test suites in ETSI EN 301 908-18 [16] that can equally be used for demonstrating conformance for Wide Area CGC

Technical requirement in the present document	Corresponding technical requirements in ETSI EN 301 908-18 [16]	Corresponding test suites in ETSI EN 301 908-18 [16]
8.2.2 Operating band unwanted emissions	4.2.2 Operating band unwanted emissions	5.3.1 Operating band unwanted emissions
8.2.3 Adjacent Channel Leakage power Ratio (ACLR)	(See note)	(See note)
8.2.4 Transmitter spurious emissions	4.2.4 Transmitter spurious emissions	5.3.3 Transmitter spurious emissions
8.2.5 CGC BS maximum output power	4.2.5 Base station maximum output power	5.3.4 Base station maximum output power
8.2.6 Transmit intermodulation	4.2.6 Transmit intermodulation	5.3.5 Transmit intermodulation
8.2.7 Receiver spurious emissions	4.2.7 Receiver spurious emissions	5.3.6 Receiver spurious emissions
8.2.8 Blocking characteristics	4.2.8 In-band blocking	5.3.7 In-band blocking
	4.2.9 Out-of-band blocking	5.3.8 Out-of-band blocking
8.2.9 Receiver intermodulation characteristics	4.2.10 Receiver intermodulation characteristics	5.3.9 Receiver intermodulation characteristics
8.2.10 Adjacent Channel Selectivity (ACS) and narrow-band blocking	4.2.11 Narrowband blocking	5.3.10 Narrowband blocking
NOTE: Conformance with the E-UTRA ACLR requirement is for an MSR CGC demonstrated through the requirement in clause 8.2.3 of the present document and the corresponding test suite in clause 9.3.2.		

8.2.2 Operating band unwanted emissions

8.2.2.0 General

For an E-UTRA Wide Area CGC additionally conforming to ETSI EN 301 908-18 [16], either the requirement of the present clause or the Operating band unwanted emissions requirement in clause 8.2.2 of ETSI EN 301 908-18 [16] can be equally applied, as listed in table 45.

8.2.2.1 Definition

Unwanted emissions consist of out-of-band emissions and spurious emissions (Recommendation ITU-R SM.329-12 [5]). Out of band emissions are emissions immediately outside the channel bandwidth resulting from the modulation process and non-linearity in the transmitter but excluding spurious emissions. The out-of-band emissions requirement for the CGC transmitter is specified both in terms of Adjacent Channel Leakage power Ratio (ACLR) and Operating band unwanted emissions.

Unless otherwise stated, the Operating band unwanted emission limits are defined from 10 MHz below the lowest frequency of the downlink operating band up to 10 MHz above the highest frequency of the downlink operating band (see table 1).

The requirements shall apply whatever the type of transmitter considered (single carrier or multi-carrier) and for all transmission modes foreseen by the manufacturer's specification.

For a CGC supporting multi-carrier, the unwanted emissions requirements apply to channel bandwidths of the outermost carrier larger than or equal to 5 MHz.

For a multicarrier E-UTRA CGC the definitions above apply to the lower edge of the carrier transmitted at the lowest carrier frequency and the higher edge of the carrier transmitted at the highest carrier frequency within a specified operating band.

The terms Wide Area BS, Local Area BS and Home BS are defined in ETSI EN 301 908-3 [4]. The definition of Wide Area CGC and Local Area CGC refer to these definitions.

8.2.2.2 Limits

8.2.2.2.0 General

Emissions shall not exceed the maximum levels specified in the tables below, where:

- Δf is the separation between the channel edge frequency and the nominal -3 dB point of the measuring filter closest to the carrier frequency.
- f_{offset} is the separation between the channel edge frequency and the centre of the measuring filter.
- $f_{\text{offset}_{\text{max}}}$ is the offset to the frequency 10 MHz outside the downlink operating band.
- Δf_{max} is equal to $f_{\text{offset}_{\text{max}}}$ minus half of the bandwidth of the measuring filter.

8.2.2.2.1 Limits for Wide Area CGC

For E-UTRA Wide Area CGC operating in the CGC frequency band provided in table 1, emissions shall not exceed the maximum levels specified in table 46.

Table 46: Wide Area CGC operating band unwanted emission limits for 5 MHz, 10 MHz and 15 MHz channel bandwidth

Frequency offset of measurement filter -3 dB point, Δf	Frequency offset of measurement filter centre frequency, f_{offset}	Test requirement	Measurement bandwidth
$0 \text{ MHz} \leq \Delta f < 0,2 \text{ MHz}$	$0,015 \text{ MHz} \leq f_{\text{offset}} < 0,215 \text{ MHz}$	-12,5 dBm	30 kHz
$0,2 \text{ MHz} \leq \Delta f < 1 \text{ MHz}$	$0,215 \text{ MHz} \leq f_{\text{offset}} < 1,015 \text{ MHz}$	$-12,5 \text{ dBm} - 15 \times \left(\frac{f_{\text{offset}}}{\text{MHz}} - 0,215 \right) \text{ dB}$	30 kHz
	$1,015 \text{ MHz} \leq f_{\text{offset}} < 1,5 \text{ MHz}$	-24,5 dBm	30 kHz
$1 \text{ MHz} \leq \Delta f \leq \min(10 \text{ MHz}, \Delta f_{\text{max}})$	$1,5 \text{ MHz} \leq f_{\text{offset}} < \min(10,5 \text{ MHz}, f_{\text{offset}_{\text{max}}})$	-11,5 dBm	1 MHz
$10 \text{ MHz} \leq \Delta f \leq \Delta f_{\text{max}}$	$10,5 \text{ MHz} \leq f_{\text{offset}} < f_{\text{offset}_{\text{max}}}$	-15 dBm (see note)	1 MHz

NOTE: The requirement is not applicable when $\Delta f_{\text{max}} < 10 \text{ MHz}$.

8.2.2.2.2 Limits for Local Area CGC

For Local Area CGC, in the E-UTRA CGC frequency band provided in table 1, emissions shall not exceed the maximum levels specified in table 47.

Table 47: Local Area CGC operating band unwanted emission limits for 5 MHz, 10 MHz and 15 MHz channel bandwidth (E-UTRA band provided in table 1)

Frequency offset of measurement filter -3 dB point, Δf	Frequency offset of measurement filter centre frequency, f_{offset}	Test requirement	Measurement bandwidth
$0 \text{ MHz} \leq \Delta f < 5 \text{ MHz}$	$0,05 \text{ MHz} \leq f_{\text{offset}} < 5,05 \text{ MHz}$	$-28,5 \text{ dBm} - \frac{7}{5} \times \left(\frac{f_{\text{offset}}}{\text{MHz}} - 0,05 \right) \text{ dB}$	100 kHz
$5 \text{ MHz} \leq \Delta f < \min(10 \text{ MHz}, \Delta f_{\text{max}})$	$5,05 \text{ MHz} \leq f_{\text{offset}} < \min(10,05 \text{ MHz}, f_{\text{offset}_{\text{max}}})$	-35,5 dBm	100 kHz
$10 \text{ MHz} \leq \Delta f \leq \Delta f_{\text{max}}$	$10,05 \text{ MHz} \leq f_{\text{offset}} < f_{\text{offset}_{\text{max}}}$	-37 dBm (see note)	100 kHz

NOTE: The requirement is not applicable when $\Delta f_{\text{max}} < 10 \text{ MHz}$.

8.2.2.3 Conformance

Conformance tests described in clause 9.3.1 shall be carried out.

8.2.3 Adjacent Channel Leakage power Ratio (ACLR)

8.2.3.1 Definition

Unwanted emissions consist of out-of-band emissions and spurious emissions (Recommendation ITU-R SM.329-12 [5]). Out of band emissions are emissions immediately outside the channel bandwidth resulting from the modulation process and non-linearity in the transmitter but excluding spurious emissions. The out-of-band emissions requirement for the CGC transmitter is specified both in terms of Adjacent Channel Leakage power Ratio (ACLR) and Operating band unwanted emissions.

Adjacent Channel Leakage power Ratio (ACLR) is the ratio of the filtered mean power centered on the assigned channel frequency to the filtered mean power centered on an adjacent channel frequency.

The requirements shall apply outside the CGC RF bandwidth edges whatever the type of transmitter considered (single carrier or multi-carrier). It applies for all transmission modes foreseen by the manufacturer's specification. The requirement applies during the transmitter ON period.

8.2.3.2 Limits

The ACLR is defined with a square filter of bandwidth equal to the transmission bandwidth configuration of the transmitted signal (BW_{Config}) centered on the assigned channel frequency and a filter centered on the adjacent channel frequency according to table 48.

For Wide Area CGC, either the ACLR limits in table 48 or the absolute limit of -15 dBm/MHz apply, whichever is less stringent.

For Local Area CGC, either the ACLR limits in table 48 or the absolute limit of -32 dBm/MHz shall apply, whichever is less stringent.

For operation in paired spectrum, the ACLR shall be higher than the value specified in table 48.

Table 48: CGC ACLR in paired spectrum

Channel bandwidth of E-UTRA lowest (highest) carrier transmitted BW_{Channel} (MHz)	CGC adjacent channel centre frequency offset below the lowest or above the highest carrier centre frequency transmitted	Assumed adjacent channel carrier (informative)	Filter on the adjacent channel frequency and corresponding filter bandwidth	ACLR limit
5, 10, 15	BW_{Channel}	E-UTRA of same BW	Square (BW_{Config})	44,2 dB
	$2 \times BW_{\text{Channel}}$	E-UTRA of same BW	Square (BW_{Config})	44,2 dB
	$BW_{\text{Channel}}/2 + 2,5 \text{ MHz}$	3,84 Mcps UTRA	RRC (3,84 Mcps)	44,2 dB
	$BW_{\text{Channel}}/2 + 7,5 \text{ MHz}$	3,84 Mcps UTRA	RRC (3,84 Mcps)	44,2 dB
NOTE 1: BW_{Channel} and BW_{Config} are the channel bandwidth and transmission bandwidth configuration of the E-UTRA lowest (highest) carrier transmitted on the assigned channel frequency.				
NOTE 2: The RRC filter shall be equivalent to the transmit pulse shape filter defined in ETSI TS 125 104 [12], with a chip rate as defined in this table.				

8.2.3.3 Conformance

Conformance tests described in clause 9.3.2 shall be carried out.

8.2.4 Transmitter spurious emissions

8.2.4.0 General

For an E-UTRA Wide Area CGC additionally conforming to ETSI EN 301 908-18 [16], either the requirement of the present clause or the Transmitter spurious emissions requirement in clause 4.2.4 of ETSI EN 301 908-18 [16] can be equally applied, as listed in table 45.

8.2.4.1 Definition

Unwanted emissions consist of out-of-band emissions and spurious emissions (Recommendation ITU-R SM.329-12 [5]). Spurious emissions are emissions which are caused by unwanted transmitter effects such as harmonics emission, parasitic emission, intermodulation products and frequency conversion products, but exclude out-of-band emissions. This is measured at the CGC Antenna connector .

The transmitter spurious emission limits apply from 9 kHz to 12,75 GHz, excluding the frequency range from 10 MHz below the lowest frequency of the downlink operating band up to 10 MHz above the highest frequency of the downlink operating band (see table 1). For some operating bands the upper frequency limit is higher than 12,75 GHz.

For a CGC supporting multi-carrier, the unwanted emissions requirements apply to channel bandwidths of the outermost carrier larger than or equal to 5 MHz.

The requirements shall apply whatever the type of transmitter considered (single carrier or multi-carrier). It applies for all transmission modes foreseen by the manufacturer's specification. Unless otherwise stated, all requirements are measured as mean power (RMS).

8.2.4.2 Limits

8.2.4.2.1 Spurious emissions

The power of any spurious emission shall not exceed the limits in table 49.

Table 49: CGC Spurious emissions limits

Frequency range	Maximum Level	Measurement Bandwidth	Note
9 kHz ↔ 150 kHz	-36 dBm	1 kHz	Note 1
150 kHz ↔ 30 MHz	-36 dBm	10 kHz	Note 1
30 MHz ↔ 1 GHz	-36 dBm	100 kHz	Note 1
1 GHz ↔ 12,75 GHz	-30 dBm	1 MHz	Note 2
12,75 GHz ↔ 5 th harmonic of the upper frequency edge of the downlink operating band	-30 dBm	1 MHz	Note 2
NOTE 1: Bandwidth as in Recommendation ITU-R SM.329-12 [5], section 4.1.			
NOTE 2: Bandwidth as in Recommendation ITU-R SM.329-12 [5], section 4.1. Upper frequency as in Recommendation ITU-R SM.329-12 [5], section 2.5 table 1.			

8.2.4.2.2 Co-existence with other systems

This requirement shall be applied for the protection of UE/MS and BS/BTS receivers of other systems.

The power of any spurious emission shall not exceed the limit specified in table 50.

Table 50: Spurious emissions limits for protection of other systems

Protected system	Frequency range for co-existence requirement	Maximum Level	Measurement Bandwidth
GSM900	921 MHz to 960 MHz	-57 dBm	100 kHz
	876 MHz to 915 MHz	-61 dBm	100 kHz
DCS1800	1 805 MHz to 1 880 MHz	-47 dBm	100 kHz
	1 710 MHz to 1 785 MHz	-61 dBm	100 kHz
UTRA FDD band I, E-UTRA band 1	2 110 MHz to 2 170 MHz	-52 dBm	1 MHz
	1 920 MHz to 1 980 MHz	-49 dBm	1 MHz
UTRA FDD band III, E-UTRA band 3	1 805 MHz to 1 880 MHz	-52 dBm	1 MHz
	1 710 MHz to 1 785 MHz	-49 dBm	1 MHz
UTRA FDD band VII, E-UTRA band 7	2 620 MHz to 2 690 MHz	-52 dBm	1 MHz
	2 500 MHz to 2 570 MHz	-49 dBm	1 MHz
UTRA FDD band VIII, E-UTRA band 8	925 MHz to 960 MHz	-52 dBm	1 MHz
	880 MHz to 915 MHz	-49 dBm	1 MHz
UTRA FDD band XV	2 600 MHz to 2 620 MHz	-52 dBm	1 MHz
	1 900 MHz to 1 920 MHz	-49 dBm	1 MHz

Protected system	Frequency range for co-existence requirement	Maximum Level	Measurement Bandwidth
UTRA FDD band XVI	2 585 MHz to 2 600 MHz	-52 dBm	1 MHz
	2 010 MHz to 2 025 MHz	-49 dBm	1 MHz
UTRA FDD band XX, E-UTRA Band 20	791 MHz to 821 MHz	-52 dBm	1 MHz
	832 MHz to 862 MHz	-49 dBm	1 MHz
UTRA FDD band XXII, E-UTRA band 22	3 510 MHz to 3 590 MHz	-52 dBm	1 MHz
	3 410 MHz to 3 490 MHz	-49 dBm	1 MHz
UTRA TDD in band a), E-UTRA band 33	1 900 MHz to 1 920 MHz	-52 dBm	1 MHz
UTRA TDD in band a), E-UTRA band 34	2 010 MHz to 2 025 MHz	-52 dBm	1 MHz
UTRA TDD in band d), E-UTRA band 38	2 570 MHz to 2 620 MHz	-52 dBm	1 MHz
UTRA TDD in band e), E-UTRA band 40	2 300 MHz to 2 400 MHz	-52 dBm	1 MHz
	3 400 MHz to 3 600 MHz	-52 dBm	1 MHz
E-UTRA band 42	3 400 MHz to 3 600 MHz	-52 dBm	1 MHz
E-UTRA band 43	3 600 MHz to 3 800 MHz	-52 dBm	1 MHz

NOTE 1: Where the table has two entries for the same or overlapping frequency ranges, both limits shall be applied.
NOTE 2: As set out in the definition in clause 8.2.4.1, the co-existence requirements in this table do not apply for the 10 MHz frequency range immediately outside the downlink operating band (see table 1). This is also the case when the downlink operating band is adjacent to the Band for the protected system in the table.

8.2.4.2.3 Protection of BS receiver

This requirement shall be applied in order to prevent the receivers of the BSs being desensitized by emissions from a CGC transmitter.

The power of any spurious emission shall not exceed the limit specified in table 51, depending on the declared CGC BS class.

The terms Wide Area BS, Local Area BS and Home BS are defined in ETSI EN 301 908-3 [4].

Table 51: CGC emissions limits for Spurious protection of a BS receiver

BS class	Frequency range	Maximum Level	Measurement Bandwidth	Note
Wide Area BS	F_{UL_low} to F_{UL_high}	-96 dBm	100 kHz	
Local Area BS	F_{UL_low} to F_{UL_high}	-88 dBm	100 kHz	
Home BS	F_{UL_low} to F_{UL_high}	-88 dBm	100 kHz	

NOTE: F_{UL_low} and F_{UL_high} are the lowest and highest frequency of the E-UTRA BS uplink operating band respectively.

8.2.4.3 Conformance

Conformance tests described in clause 9.3.3 shall be carried out.

8.2.5 CGC BS maximum output power

8.2.5.0 General

For an E-UTRA Wide Area CGC additionally conforming to ETSI EN 301 908-18 [16], either the requirement of the present clause or the CGC BS maximum output power requirement in clause 4.2.5 of ETSI EN 301 908-18 [16] can be equally applied, as listed in table 45.

8.2.5.1 Definition

The maximum output power, $P_{max,c}$ of the CGC is the mean power level per carrier measured at the antenna connector during the transmitter ON period in a specified reference condition.

8.2.5.2 Limit

In normal conditions, the CGC maximum output power shall remain within:

+2,7 dB and -2,7 dB of the manufacturer's rated output power.

In extreme conditions, the CGC maximum output power shall remain within:

+3,2 dB and -3,2 dB of the manufacturer's rated output power.

8.2.5.3 Conformance

Conformance tests described in clause 9.3.4 shall be carried out.

8.2.6 Transmitter intermodulation

8.2.6.0 General

For an E-UTRA Wide Area CGC additionally conforming to ETSI EN 301 908-18 [16], either the requirement of the present clause or the Transmitter intermodulation requirement in clause 4.2.6 of ETSI EN 301 908-18 [16] can be equally applied, as listed in table 45.

8.2.6.1 Definition

The transmitter intermodulation requirement is a measure of the capability of the transmitter to inhibit the generation of signals in its non-linear elements caused by presence of the own transmit signal and an interfering signal reaching the transmitter via the antenna. The requirement applies during the transmitter ON period and the transmitter transient period.

The transmitter intermodulation level is the power of the intermodulation products when an interfering signal is injected into the antenna connector.

The requirements shall apply whatever the type of transmitter considered (single carrier or multi-carrier). It applies for all transmission modes foreseen by the manufacturer's specification.

8.2.6.2 Limit

The wanted signal channel bandwidth BW_{Channel} shall be the maximum channel bandwidth supported by the CGC.

In the frequency range relevant for this test, the transmit intermodulation level shall not exceed the unwanted emission requirements of clauses 8.2.2.2, 4.2.3.2 and 8.2.4.2 in the presence of an interfering signal according to table 52.

Table 52: Interfering and wanted signals for the Transmitter intermodulation requirement

Parameter	Value
Wanted signal	Single-carrier or multi-carrier E-UTRA signal(s) of maximum channel bandwidth BW_{Channel} supported by the CGC
Interfering signal type	E-UTRA signal of channel bandwidth 5 MHz
Interfering signal level	Mean power level 30 dB below the mean power of the wanted signal
Interfering signal centre frequency offset from the lower (higher) edge of the wanted signal	±2,5 MHz ±7,5 MHz ±12,5 MHz
NOTE:	Interfering signal positions that are partially or completely outside of the downlink operating band of the CGC are excluded from the requirement, unless the interfering signal positions fall within the frequency range of adjacent downlink operating bands in the same geographical area.

In case that none of the interfering signal positions according to the conditions of table 52 is applicable, a wanted signal channel bandwidth BW_{Channel} less than the maximum channel bandwidth supported by the CGC shall be selected so that at least one applicable interfering signal position according to table 52 is obtained. If the CGC does not support any channel bandwidths less than the maximum supported bandwidth, an interfering signal outside or partly outside the downlink operating band shall be used.

The measurements for unwanted emission requirement due to intermodulation can be limited to the frequency ranges of all third and fifth order intermodulation products, excluding the channel bandwidths of the wanted and interfering signals.

8.2.6.3 Conformance

Conformance tests described in clause 9.3.5 shall be carried out.

8.2.7 Receiver spurious emissions

8.2.7.0 General

For an E-UTRA Wide Area CGC additionally conforming to ETSI EN 301 908-18 [16], either the requirement of the present clause or the Receiver spurious emissions requirement in clause 4.2.7 of ETSI EN 301 908-18 [16] can be equally applied, as listed in table 45.

8.2.7.1 Definition

The spurious emissions power is the power of emissions generated or amplified in a receiver that appear at the CGC receiver antenna connector. The requirements apply to all CGC with separate RX and TX antenna ports. The test shall be performed when both TX and RX are on, with the TX port terminated.

For TDD CGC with common RX and TX antenna port the requirement applies during the Transmitter OFF period. For FDD CGC with common RX and TX antenna port the transmitter spurious emission as specified in clause 8.2.4 is valid.

8.2.7.2 Limit

The power of any spurious emission shall not exceed the levels in table 53.

In addition to the requirements in table 53, the power of any spurious emission shall not exceed the limits specified in clauses 8.2.4.2.2 and 8.2.4.2.3.

Table 53: General spurious emission test requirement

Frequency range	Maximum level	Measurement Bandwidth	Note
30 MHz to 1 GHz	-57 dBm	100 kHz	
1 GHz to 12,75 GHz	-47 dBm	1 MHz	
12,75 GHz to 5th harmonic of the upper frequency edge of the downlink operating band	-47 dBm	1 MHz	Applies only for Bands 22, 42 and 43.
NOTE: The frequency range between $2,5 \times BW_{\text{Channel}}$ below the first carrier frequency and $2,5 \times BW_{\text{Channel}}$ above the last carrier frequency transmitted by the CGC, where BW_{Channel} is the channel bandwidth according to ETSI TS 136 141 [11], table 5.6-1, may be excluded from the requirement. However, frequencies that are more than 10 MHz below the lowest frequency of the downlink operating band or more than 10 MHz above the highest frequency of the downlink operating band (see table 50) shall not be excluded from the requirement.			

8.2.7.3 Conformance

Conformance tests described in clause 9.3.6 shall be carried out.

8.2.8 Blocking characteristics

8.2.8.0 General

For an E-UTRA Wide Area CGC additionally conforming to ETSI EN 301 908-18 [16], either the requirement of the present clause or the In-band and Out-of-band blocking requirements in clauses 4.2.8 and 4.2.9 of ETSI EN 301 908-18 [16] can be equally applied, as listed in table 45.

8.2.8.1 Definition

The blocking characteristics is a measure of the receiver ability to receive a wanted signal at its assigned channel in the presence of an unwanted interferer, on frequencies other than those of the adjacent channel.

8.2.8.2 Limit

The throughput shall be ≥ 95 % of the maximum throughput of the reference measurement channel, with a wanted and an interfering signal coupled to CGC antenna input using the parameters in tables 54, 55 or 56.

Table 54: Blocking performance requirement for Wide Area CGC

Operating Band	Centre Frequency of Interfering Signal (MHz) (see note 1)	Interfering Signal mean power (dBm)	Wanted Signal mean power (dBm) (see note 2)	Interfering signal centre frequency minimum frequency offset from the lower (higher) edge (MHz)	Type of Interfering Signal
Table 1	$(F_{UL_low} - 20)$ to $(F_{UL_high} + 20)$	-43	$P_{REFSENS} + 6$ dB	See table 58	See table 58
	1 to $(F_{UL_low} - 20)$ $(F_{UL_high} + 20)$ to 12 750	-15	$P_{REFSENS} + 6$ dB	-	CW carrier

NOTE 1: F_{UL_low} and F_{UL_high} are the lowest and highest frequencies of the uplink operating band, as defined in table 1.

NOTE 2: $P_{REFSENS}$ depends on the channel bandwidth as specified in ETSI TS 136 141 [11], clause 7.2.

Table 55: Blocking performance requirement for Local Area CGC

Operating Band	Centre Frequency of Interfering Signal (MHz) (see note 1)	Interfering Signal mean power (dBm)	Wanted Signal mean power (dBm) (see note 2)	Interfering signal centre frequency minimum frequency offset from the channel edge of the wanted signal (MHz)	Type of Interfering Signal
Table 1	$(F_{UL_low} - 20)$ to $(F_{UL_high} + 20)$	-35	$P_{REFSENS} + 6$ dB	See table 58	See table 58
	1 to $(F_{UL_low} - 20)$ $(F_{UL_high} + 20)$ to 12 750	-15	$P_{REFSENS} + 6$ dB	-	CW carrier

NOTE 1: F_{UL_low} and F_{UL_high} are the lowest and highest frequencies of the uplink operating band, as defined in table 1.

NOTE 2: $P_{REFSENS}$ depends on the channel bandwidth as specified in ETSI TS 136 141 [11], clause 7.2.

Table 56: Interfering signals for Blocking performance requirement

E-UTRA channel BW of the lowest (highest) carrier received (MHz)	Interfering signal centre frequency minimum offset to the lower (higher) edge (MHz)	Type of interfering signal
5	$\pm 7,5$	5 MHz E-UTRA signal
10	$\pm 7,5$	5 MHz E-UTRA signal
15	$\pm 7,5$	5 MHz E-UTRA signal

8.2.8.3 Conformance

Conformance tests described in clause 9.3.7 shall be carried out.

8.2.9 Receiver intermodulation characteristics

8.2.9.0 General

For an E-UTRA Wide Area CGC additionally conforming to ETSI EN 301 908-18 [16], either the requirement of the present clause or the Receiver intermodulation requirement in clause 4.2.10 of ETSI EN 301 908-18 [16] can be equally applied, as listed in table 45.

8.2.9.1 Definition

Third and higher order mixing of the two interfering RF signals can produce an interfering signal in the band of the desired channel. Intermodulation response rejection is a measure of the capability of the receiver to receive a wanted signal on its assigned channel frequency in the presence of two interfering signals which have a specific frequency relationship to the wanted signal. Interfering signals shall be a CW signal and an E-UTRA signal as specified in ETSI TS 136 141 [11], annex C.

8.2.9.2 Limit

The throughput shall be ≥ 95 % of the maximum throughput of the reference measurement channel, with a wanted signal at the assigned channel frequency and two interfering signals with the conditions specified in tables 57 and 58 for intermodulation performance and in tables 59 or 60 depending on the declared CGC class for narrowband intermodulation performance. The reference measurement channel for the wanted signal is identified in tables 7.2-1, 7.2-2 or 7.2-3 of ETSI TS 136 141 [11] for each channel bandwidth and further specified in annex A of ETSI TS 136 141 [11].

Table 57: Intermodulation performance requirement

CGC class	Wanted signal mean power (dBm)	Interfering signal mean power	Type of interfering signal
Wide area CGC	$P_{\text{REFSENS}} + 6$ dB (see note)	-52 dBm	See table 58
Local Area CGC	$P_{\text{REFSENS}} + 6$ dB (see note)	-44 dBm	
NOTE: P_{REFSENS} depends on the channel bandwidth as specified in ETSI TS 136 141 [11], clause 7.2. For E-UTRA channel bandwidths 10 MHz, 15 MHz this requirement shall apply only for a FRC A1-3 (see ETSI TS 136 141 [11], clause A.1) mapped to the frequency range at the channel edge adjacent to the interfering signals.			

Table 58: Interfering signal for Intermodulation performance requirement

E-UTRA channel bandwidth of the lowest (highest) carrier received (MHz)	Interfering signal centre frequency offset from the lower (higher) edge (MHz)	Type of interfering signal
5	$\pm 7,5$	CW
	$\pm 17,5$	5 MHz E-UTRA signal
10	$\pm 7,375$	CW
	$\pm 17,5$	5 MHz E-UTRA signal
15	$\pm 7,25$	CW
	$\pm 17,5$	5 MHz E-UTRA signal

Table 59: Narrowband intermodulation performance requirement for Wide Area CGC

E-UTRA channel bandwidth of the lowest (highest) carrier received (MHz)	Wanted signal mean power (dBm)	Interfering signal mean power (dBm)	Interfering RB centre frequency offset from the lower (higher) edge (kHz)	Type of interfering signal
5	$P_{\text{REFSENS}} + 6 \text{ dB}$ (see note 1)	-52	± 360	CW
		-52	$\pm 1\,060$	5 MHz E-UTRA signal, 1 RB (see note 2)
10	$P_{\text{REFSENS}} + 6 \text{ dB}$ (see notes 1 and 3)	-52	± 325	CW
		-52	$\pm 1\,240$	5 MHz E-UTRA signal, 1 RB (see note 2)
15	$P_{\text{REFSENS}} + 6 \text{ dB}$ (see notes 1 and 3)	-52	± 380	CW
		-52	$\pm 1\,600$	5 MHz E-UTRA signal, 1 RB (see note 2)

NOTE 1: P_{REFSENS} is related to the channel bandwidth as specified in ETSI TS 136 141 [11], clause 7.2.
NOTE 2: Interfering signal consisting of one resource block positioned at the stated offset, the channel bandwidth of the interfering signal is located adjacently to the channel bandwidth of the lower (higher) edge.
NOTE 3: This requirement shall apply only for an FRC A1-3 (see ETSI TS 136 141 [11], clause A.1) mapped to the frequency range at the channel edge adjacent to the interfering signals.

Table 60: Narrowband intermodulation performance requirement for Local Area CGC

E-UTRA channel bandwidth (MHz)	Wanted signal mean power (dBm)	Interfering signal mean power (dBm)	Interfering RB centre frequency offset from the channel edge of the wanted signal (kHz)	Type of interfering signal
5	$P_{\text{REFSENS}} + 6 \text{ dB}$ (see note 1)	-44	360	CW
		-44	1 060	5 MHz E-UTRA signal, 1 RB (see note 2)
10	$P_{\text{REFSENS}} + 6 \text{ dB}$ (see notes 1 and 3)	-44	325	CW
		-44	1 240	5 MHz E-UTRA signal, 1 RB (see note 2)
15	$P_{\text{REFSENS}} + 6 \text{ dB}$ (see notes 1 and 3)	-44	380	CW
		-44	1 600	5 MHz E-UTRA signal, 1 RB (see note 2)

NOTE 1: P_{REFSENS} is related to the channel bandwidth as specified in ETSI TS 136 141 [11], clause 7.2.
NOTE 2: Interfering signal consisting of one resource block positioned at the stated offset, the channel bandwidth of the interfering signal is located adjacently to the channel bandwidth of the wanted signal.
NOTE 3: This requirement shall apply only for an FRC A1-3 (see ETSI TS 136 141 [11], clause A.1) mapped to the frequency range at the channel edge adjacent to the interfering signals.

8.2.9.3 Conformance

Conformance tests described in clause 9.3.8 shall be carried out.

8.2.10 Adjacent Channel Selectivity (ACS) and narrow-band blocking

8.2.10.0 General

For an E-UTRA Wide Area CGC additionally conforming to ETSI EN 301 908-18 [16], either the requirement of the present clause or the Narrowband blocking requirement in clause 4.2.11 of ETSI EN 301 908-18 [16] can be equally applied, as listed in table 45.

8.2.10.1 Definition

Adjacent Channel Selectivity (ACS) and narrow-band blocking are measures of the receiver's ability to receive a wanted signal at its assigned channel frequency in the presence of an adjacent channel signal with a specified centre frequency offset of the interfering signal to the channel edge of a victim system. The interfering signal shall be an E-UTRA signal as specified in ETSI TS 136 141 [11], annex C. For narrowband blocking, the interfering signal is an E-UTRA single Resource Block.

8.2.10.2 Limit

The throughput shall be ≥ 95 % of the maximum throughput of the reference measurement channel.

For Wide Area CGC, the wanted and the interfering signal coupled to the CGC antenna input are specified in tables 61 and 62 for narrowband blocking and table 63 for ACS. The reference measurement channel for the wanted signal is identified in table 7.2-1 of ETSI TS 136 141 [11] for each channel bandwidth and further specified in annex A of ETSI TS 136 141 [11].

For Local Area CGC, the wanted and the interfering signal coupled to the CGC antenna input are specified in tables 61 and 62 for narrowband blocking and table 64 for ACS. The reference measurement channel for the wanted signal is identified in table 7.2-2 of ETSI TS 136 141 [11] for each channel bandwidth and further specified in annex A of ETSI TS 136 141 [11].

Table 61: Narrowband blocking requirement

CGC class	Wanted signal mean power (dBm)	Interfering signal mean power	Type of interfering signal
Wide Area CGC	$P_{\text{REFSENS}} + 6$ dB (see note)	-49 dBm	See table 62
Local Area CGC	$P_{\text{REFSENS}} + 6$ dB (see note)	-41 dBm	See table 62
NOTE: P_{REFSENS} depends on the channel bandwidth as specified in ETSI TS 136 141 [11], clause 7.2.			

Table 62: Interfering signal for Narrowband blocking requirement

E-UTRA channel BW of the lowest (highest) carrier received (MHz)	Interfering RB centre frequency offset to the lower (higher) edge (kHz)	Type of interfering signal
5	$\pm(342,5 + m \times 180)$, $m = 0, 1, 2, 3, 4, 9, 14, 19, 24$	5 MHz E-UTRA signal, 1 RB (see note)
10	$\pm(347,5 + m \times 180)$, $m = 0, 1, 2, 3, 4, 9, 14, 19, 24$	5 MHz E-UTRA signal, 1 RB (see note)
15	$\pm(352,5 + m \times 180)$, $m = 0, 1, 2, 3, 4, 9, 14, 19, 24$	5 MHz E-UTRA signal, 1 RB (see note)
NOTE: Interfering signal consisting of one resource block is positioned at the stated offset, the channel bandwidth of the interfering signal is located adjacently to the lower (higher) edge. Frequency offsets are such that the interfering signal is outside the channel.		

Table 63: Adjacent channel selectivity for Wide Area CGC

E-UTRA channel bandwidth of the lowest (highest) carrier received (MHz)	Wanted signal mean power (dBm)	Interfering signal mean power (dBm)	Interfering signal centre frequency offset from the lower (higher) edge (MHz)	Type of [11] interfering signal
5	$P_{\text{REFSENS}} + 6 \text{ dB}$ (see note)	-52	$\pm 2,5025$	5 MHz E-UTRA signal
10	$P_{\text{REFSENS}} + 6 \text{ dB}$ (see note)	-52	$\pm 2,5075$	5 MHz E-UTRA signal
15	$P_{\text{REFSENS}} + 6 \text{ dB}$ (see note)	-52	$\pm 2,5125$	5 MHz E-UTRA signal

NOTE: P_{REFSENS} depends on the channel bandwidth as specified in ETSI TS 136 141 [11], clause 7.2.
Frequency offsets are such that the interfering signal is outside the channel.

Table 64: Adjacent channel selectivity for Local Area CGC

E-UTRA channel bandwidth (MHz)	Wanted signal mean power (dBm)	Interfering signal mean power (dBm)	Interfering signal centre frequency offset from the channel edge of the wanted signal (MHz)	Type of interfering signal
5	$P_{\text{REFSENS}} + 6 \text{ dB}$ (see note)	-44	2,5025	5 MHz E-UTRA signal
10	$P_{\text{REFSENS}} + 6 \text{ dB}$ (see note)	-44	2,5075	5 MHz E-UTRA signal
15	$P_{\text{REFSENS}} + 6 \text{ dB}$ (see note)	-44	2,5125	5 MHz E-UTRA signal

NOTE: P_{REFSENS} depends on the channel bandwidth as specified in ETSI TS 136 141 [11], clause 7.2.
Frequency offsets are such that the interfering signal is outside the channel.

8.2.10.3 Conformance

Conformance tests described in clause 9.3.9 shall be carried out.

9 Testing for compliance with technical requirements for conventional CGC E-UTRA

9.1 Environmental conditions for testing

Tests defined in the present document shall be carried out at representative points within the boundary limits of the declared operational environmental profile.

Where technical performance varies subject to environmental conditions, tests shall be carried out under a sufficient variety of environmental conditions (within the boundary limits of the declared operational environmental profile) to give confidence of compliance for the affected technical requirements.

Normally it should be sufficient for all tests to be conducted using normal test conditions except where otherwise stated. For guidance on the use of other test conditions to be used in order to show compliance reference can be made to ETSI TS 136 141 [11], annex D.

For the single carrier testing many tests in the present document are performed with appropriate frequencies in the bottom, middle and top of the operating band of the CGC. These are denoted as RF channels B (bottom), M (middle) and T (top) and are defined in ETSI TS 136 141 [11], clause 4.7. For the non-single carrier testing many tests in the present document are performed with the maximum RF bandwidth position located at the bottom, middle and top of the supported frequency range in each operating band. These are denoted as B_{RFBW} (bottom), M_{RFBW} (middle) and T_{RFBW} (top) for non-aggregated channels and are defined in ETSI TS 136 141 [11], clause 4.7.1.

The measurement system required for each test is described in ETSI TS 136 141 [11], annex I.

9.2 Interpretation of the measurement results

The interpretation of the results recorded in a test report for the measurements described in the present document shall be as follows:

- the measured value related to the corresponding limit will be used to decide whether an equipment meets the requirements of the present document;
- the value of the measurement uncertainty for the measurement of each parameter shall be included in the test report;
- the recorded value of the measurement uncertainty shall be, for each measurement, equal to or lower than the figures in table 65.

For the test methods, according to the present document, the measurement uncertainty figures shall be calculated and shall correspond to an expansion factor (coverage factor) $k = 1,96$ (which provide confidence levels of respectively 95 % in the case where the distributions characterizing the actual measurement uncertainties are normal (Gaussian)). Principles for the calculation of measurement uncertainty are contained in ETSI TR 100 028 [i.1], in particular in annex D of ETSI TR 100 028-2 [i.1].

Table 65 is based on such expansion factors.

Table 65: Maximum measurement uncertainty

Parameter	Condition	Uncertainty
Operating band unwanted emissions	$f \leq 3,0$ GHz	$\pm 1,5$ dB
	$3,0$ GHz $< f \leq 4,2$ GHz	$\pm 1,8$ dB
Adjacent Channel Leakage power Ratio (ACLR)	ACLR	$\pm 0,8$ dB
	For absolute power requirements: $f \leq 3,0$ GHz	$\pm 2,0$ dB
	$3,0$ GHz $< f \leq 4,2$ GHz	$\pm 2,5$ dB
Transmitter spurious emissions	For "Spurious emissions"	
	9 kHz $< f \leq 4$ GHz	$\pm 2,0$ dB
	4 GHz $< f \leq 19$ GHz	$\pm 4,0$ dB
	For co-existence requirements (> -60 dBm)	$\pm 2,0$ dB
	For co-existence requirements (≤ -60 dBm)	$\pm 3,0$ dB
	For protection of the BS receiver	$\pm 3,0$ dB
CGC maximum output power	$f \leq 3,0$ GHz	$\pm 0,7$ dB
	$3,0$ GHz $< f \leq 4,2$ GHz	$\pm 1,0$ dB
Transmitter intermodulation	For Operating band unwanted emissions	$\pm 2,5$ dB
	For ACLR	$\pm 2,2$ dB
	For "Spurious emissions":	
	$f \leq 2,2$ GHz	$\pm 2,5$ dB
	$2,2$ GHz $< f \leq 4$ GHz	$\pm 2,8$ dB
	$f > 4$ GHz	$\pm 4,5$ dB
For co-existence requirements	$\pm 2,8$ dB	
	Interference signal	$\pm 1,0$ dB
Receiver spurious emissions	30 MHz $\leq f \leq 4$ GHz	$\pm 2,0$ dB
	4 GHz $< f \leq 19$ GHz	$\pm 4,0$ dB
Blocking characteristics	In-band blocking, using modulated interferer:	
	$f \leq 3,0$ GHz	$\pm 1,6$ dB
	$3,0$ GHz $< f \leq 4,2$ GHz	$\pm 2,0$ dB
	Out of band blocking, using CW interferer:	
	1 MHz $< f_{\text{interferer}} \leq 3$ GHz	$\pm 1,3$ dB
	3 GHz $< f_{\text{interferer}} \leq 4,2$ GHz	$\pm 1,6$ dB
		$\pm 3,2$ dB

Parameter	Condition	Uncertainty
	$4,2 \text{ GHz} < f_{\text{interferer}} \leq 12,75 \text{ GHz}$	
Receiver intermodulation characteristics	$f \leq 3,0 \text{ GHz}$ $3,0 \text{ GHz} < f \leq 4,2 \text{ GHz}$	$\pm 1,8 \text{ dB}$ $\pm 2,4 \text{ dB}$
Adjacent Channel Selectivity (ACS) and narrow-band blocking	$f \leq 3,0 \text{ GHz}$ $3,0 \text{ GHz} < f \leq 4,2 \text{ GHz}$	$\pm 1,4 \text{ dB}$ $\pm 1,8 \text{ dB}$
NOTE 1: For RF tests, it should be noted that the uncertainties in table 65 apply to the test system operating into a nominal 50 Ω load and do not include system effects due to mismatch between the EUT and the Test System.		
NOTE 2: Annex G of ETSI TR 100 028-2 [i.1] provides guidance for the calculation of the uncertainty components relating to mismatch.		
NOTE 3: If the test system for a test is known to have a measurement uncertainty greater than that specified in table 65, this equipment can still be used, provided that an adjustment is made follows: any additional uncertainty in the test system over and above that specified in table 65 is used to tighten the test requirements - making the test harder to pass (for some tests, e.g. receiver tests, this may require modification of stimulus signals). This procedure will ensure that a test system not compliant with table 65 does not increase the probability of passing an EUT that would otherwise have failed a test if a test system compliant with table 65 had been used.		

9.3 Radio test suites

9.3.0 General

This clause describes the test suites for E-UTRA (FDD and TDD).

The test configurations and channel spacing for non-single carrier operations shall be used for demonstrating conformance are specified in clauses 4.10, 5.7.1 and 5.7.1A of ETSI TS 136 141 [11].

Unless otherwise stated, each test suite to be performed with the lowest and the highest bandwidth supported by the CGC. The manufacturer shall declare that the requirements are fulfilled for all other bandwidths supported by the CGC which are not tested.

9.3.1 Operating band unwanted emissions

9.3.1.0 General

For an E-UTRA Wide Area CGC additionally conforming to ETSI EN 301 908-18 [16], either the test suite of the present clause or the Operating band unwanted emissions test suite in clause 5.3.1 of ETSI EN 301 908-18 [16] can be equally applied, as listed in table 45.

9.3.1.1 Initial conditions

Test environment: normal, see ETSI TS 136 141 [11], clause D.2.

RF channels to be tested: B, M and T, see clause 9.1.

- 1) Connect the signal analyser to the CGC Antenna connector as shown in ETSI TS 136 141 [11], clause I.1.1.

As a general rule, the resolution bandwidth of the measuring equipment should be equal to the measurement bandwidth. However, to improve measurement accuracy, sensitivity, efficiency and avoiding e.g. carrier leakage, the resolution bandwidth may be smaller than the measurement bandwidth. When the resolution bandwidth is smaller than the measurement bandwidth, the result should be integrated over the measurement bandwidth in order to obtain the equivalent noise bandwidth of the measurement bandwidth.

- 2) Detection mode: true RMS.

9.3.1.2 Procedure

- 1) Set the CGC transmission at maximum total power (P_{max}) as specified by the supplier. Channel set-up shall be according to E-TM 1.1 in ETSI TS 136 141 [11].
- 2) Step the centre frequency of the measurement filter in contiguous steps and measure the emission within the specified frequency ranges with the specified measurement bandwidth.

- 3) Repeat the test with the channel set-up according to E-TM 1.2 in ETSI TS 136 141 [11].

The results obtained shall be compared to the limits in clause 8.2.2.2 in order to prove compliance.

9.3.2 Adjacent Channel Leakage power Ratio (ACLR)

9.3.2.1 Initial conditions

Test environment: normal, see ETSI TS 136 141 [11], clause D.2.

RF channels to be tested: B, M and T; see clause 9.1.

RF bandwidth position to be tested: B_{RFBW} , M_{RFBW} and T_{RFBW} ; see clause 9.1.

- 1) Connect measurement device to the CGC Antenna connector as shown in ETSI TS 136 141 [11], clause I.1.1.
- 2) The measurement device characteristics shall be:
 - measurement filter bandwidth: defined in clause 8.2.3.2;
 - detection mode: true RMS voltage or true average power.
- 3) Set the CGC to transmit a signal according to E-TM1 in ETSI TS 136 141 [11]. The mean power at the Antenna connector shall be the maximum output power as specified by the manufacturer.
- 4) Set carrier frequency within the frequency band supported by CGC.

9.3.2.2 Procedure

- 1) Measure Adjacent channel leakage power ratio for the frequency offsets both side of channel frequency as specified in table 48 (Paired spectrum case). In multiple carrier case only offset frequencies below the lowest and above the highest carrier frequency transmitted shall be measured.

Repeat the test with the channel set-up according to E-TM1.2 in ETSI TS 136 141 [11].

The results obtained shall be compared to the limits in clause 8.2.3.2 in order to prove compliance.

9.3.3 Transmitter spurious emissions

9.3.3.0 General

For an E-UTRA Wide Area CGC additionally conforming to ETSI EN 301 908-18 [16], either the test suite of the present clause or the Transmitter spurious emissions test suite in clause 5.3.3 of ETSI EN 301 908-18 [16] can be equally applied, as listed in table 45.

9.3.3.1 Initial conditions

Test environment: normal, see ETSI TS 136 141 [11], clause D.2.

RF channels to be tested: B, M and T, see clause 9.1.

- 1) Connect the CGC antenna connector to a measurement receiver according to ETSI TS 136 141 [11], clause I.1.1 using an attenuator or a directional coupler if necessary.

Measurements shall use a measurement bandwidth in accordance to the conditions in ETSI TS 136 104 [15], clause 6.6.4.

Detection mode: true RMS.

Configure the CGC with transmitters active at their maximum output power.

9.3.3.2 Procedure

- 1) Set the CGC to transmit a signal according to E-TM1.1 in ETSI TS 136 141 [11] at the manufacturer's specified maximum output power.

- 2) Measure the emission at the specified frequencies with specified measurement bandwidth and note that the measured value does not exceed the specified value.

The results obtained shall be compared to the limits in clause 8.2.4.2 in order to prove compliance.

9.3.4 CGC maximum output power

9.3.4.0 General

For an EUTRA Wide Area CGC additionally conforming to ETSI EN 301 908-18 [16], either the test suite of the present clause or the CGC maximum output power test suite in clause 5.3.4 of ETSI EN 301 908-18 [16] can be equally applied, as listed in table 45.

9.3.4.1 Initial conditions

Test environment: normal, see ETSI TS 136 141 [11], clause D.2.

RF channels to be tested: B, M and T, see clause 9.1.

RF bandwidth position to be tested: B_{RFBW} , M_{RFBW} and T_{RFBW} ; see clause 9.1.

In addition, on one EARFCN only, the test shall be performed under extreme power supply as defined in ETSI TS 136 141 [11], clause D.5.

NOTE: Tests under extreme power supply also test extreme temperature.

- 1) Connect the power measuring equipment to the CGC Antenna connector as shown in ETSI TS 136 141 [11], clause I.1.1.

9.3.4.2 Procedure

- 1) Set the CGC to transmit a signal according to E-TM1.1 in ETSI TS 136 141 [11].
- 2) Measure the mean power for each carrier at the Antenna connector.

The results obtained shall be compared to the limits in clause 8.2.5.2 in order to prove compliance.

9.3.5 Transmitter intermodulation

9.3.5.0 General

For an EUTRA Wide Area CGC additionally conforming to ETSI EN 301 908-18 [16], either the test suite of the present clause or the Transmitter intermodulation test suite in clause 5.3.5 of ETSI EN 301 908-18 [16] can be equally applied, as listed in table 45.

9.3.5.1 Initial conditions

Test environment: normal, see ETSI TS 136 141 [11], clause D.2.

RF channels to be tested: B, M and T, see clause 9.1.

RF bandwidth position to be tested: B_{RFBW} , M_{RFBW} and T_{RFBW} ; see clause 9.1.

The wanted signal channel bandwidth $BW_{Channel}$ shall be the maximum channel bandwidth supported by the CGC.

Connect the signal analyser to the CGC Antenna connector as shown in ETSI TS 136 141 [11], clause I.1.2.

9.3.5.2 Procedures

- 1) Generate the wanted signal according to E-TM1.1 in ETSI TS 136 141 [11] at specified maximum output power, P_{max} .
- 2) Generate the interfering signal according to E-TM1.1 in ETSI TS 136 141 [11], with 5 MHz channel bandwidth and a centre frequency offset according to the conditions of table 4.2.6.2-1.

- 3) Adjust ATT1 so that level of the E-UTRA modulated interfering signal is as defined in clause 4.2.6.2.
- 4) Perform the unwanted emission tests as specified in clauses 9.3.1 and 9.3.2, for all third and fifth order intermodulation products which appear in the frequency ranges defined in clauses 9.3.1 and 9.3.2. The width of the intermodulation products shall be taken into account.
- 5) Perform the Transmitter spurious emissions test as specified in clause 9.3.3, for all third and fifth order intermodulation products which appear in the frequency ranges defined in clause 9.3.3. The width of the intermodulation products shall be taken into account.
- 6) Verify that the emission level does not exceed the required level with the exception of interfering signal frequencies.
- 7) Repeat the test for the remaining interfering signal centre frequency offsets according to the conditions of table 52.

NOTE: The third order intermodulation products are centred at $2F1 \pm F2$ and $2F2 \pm F1$. The fifth order intermodulation products are centred at $3F1 \pm 2F2$, $3F2 \pm 2F1$, $4F1 \pm F2$, and $4F2 \pm F1$ where $F1$ represents the wanted signal centre frequency and $F2$ represents the interfering signal centre frequency. The width of intermodulation products is:

- $(n \times BW_{\text{Channel}} + m \times 5 \text{ MHz})$ for the $nF1 \pm mF2$ products;
- $(n \times 5 \text{ MHz} + m \times BW_{\text{Channel}})$ for the $nF2 \pm mF1$ products.

The results obtained shall be compared to the limits in clause 8.2.6.2 in order to prove compliance.

9.3.6 Receiver spurious emissions

9.3.6.0 General

For an E-UTRA Wide Area CGC additionally conforming to ETSI EN 301 908-18 [16], either the test suite of the present clause or the Receiver spurious emissions test suite in clause 5.3.6 of ETSI EN 301 908-18 [16] can be equally applied, as listed in table 45.

9.3.6.1 Initial conditions

Test environment: normal, see ETSI TS 136 141 [11], clause D.2.

RF channels to be tested: M, see clause 9.1.

RF bandwidth position to be tested: M_{RFBW} , see clause 9.1.

- 1) Connect a measurement receiver to the CGC antenna connector as shown in ETSI TS 136 141 [11], clause I.2.6.
- 2) Enable the CGC receiver.
- 3) Terminate the CGC TX antenna connector as shown in ETSI TS 136 141 [11], clause I.2.6.

9.3.6.2 Procedure

- 1) Start CGC transmission according to E-TM 1.1 in ETSI TS 136 141 [11] at P_{max} , for multi-carrier operation start CGC transmission according to applicable test configuration in ETSI TS 136 141 [11], clause 4.10 with the sum of the carrier powers equals to P_{max} .
- 2) Set measurement equipment parameters as specified in table 53.
- 3) Measure the spurious emissions over each frequency range described in clause 8.2.7.2.
- 4) Repeat the test using diversity antenna connector if available.

The results obtained shall be compared to the limits in clause 8.2.7.2 in order to prove compliance.

9.3.7 Blocking characteristics

9.3.7.0 General

For an E-UTRA Wide Area CGC additionally conforming to ETSI EN 301 908-18 [16], either the test suite of the present clause or the In-band and Out-of-band blocking test suites in clauses 5.3.7 and 5.3.8 of ETSI EN 301 908-18 [16] can be equally applied, as listed in table 45.

9.3.7.1 Initial conditions

Test environment: normal, see ETSI TS 136 141 [11], clause D.2.

RF channels to be tested: M see clause 9.1.

RF bandwidth position to be tested: M_{RFBW} , see clause 9.1.

The CGC shall be configured to operate as close to the centre of the operating band (see table 1) as possible.

Channel bandwidths to be tested:

- a) In the frequency range ($F_{\text{UL_low}} - 20$) MHz to ($F_{\text{UL_high}} + 20$) MHz the requirement shall be tested with the lowest and the highest bandwidth supported by the CGC.
- b) In the frequency ranges 1 MHz to ($F_{\text{UL_low}} - 20$) MHz and ($F_{\text{UL_high}} + 20$) MHz to 12 750 MHz the requirement shall be tested only with the lowest bandwidth supported by the CGC.
 - 1) Connect the signal generator for the wanted signal and the signal generator for the interfering signal to the antenna connector of one RX port according to as shown in ETSI TS 136 141 [11], clause I.2.5.
 - 2) Terminate any other RX port not under test.
 - 3) Start to transmit according to reference measurement channel as shown in ETSI TS 136 141 [11], clause A.1 to the CGC under test. The level of the wanted signal measured at the CGC antenna connector shall be set to the level specified in clause 4.2.8.2.

9.3.7.2 Procedure

- 1) For FDD CGC start CGC transmission according to E-TM 1.1 in ETSI TS 136 141 [11] at P_{max} , for multi-carrier operation start CGC transmission according to applicable test configuration in clause 4.10 of ETSI TS 136 141 [11] with the same carrier locations used for the wanted signal with the sum of the carrier powers equal to P_{max} .

The transmitter may be turned off for the out-of-band blocker tests when the frequency of the blocker is such that no IM2 or IM3 products fall inside the bandwidth of the wanted signal.

- 2) Adjust the signal generators to the type of interfering signals, levels and the frequency offsets as specified in tables 54 or 55. The E-UTRA interfering signal shall be swept with a step size of 1 MHz starting from the minimum offset to the channel edges of the wanted signal as specified in table 56. The CW interfering signal shall be swept with a step size of 1 MHz within the range specified in tables 54 or 55.
- 3) Measure the throughput of the wanted signal at the CGC receiver according to ETSI TS 136 141 [11], annex E, for multi-carrier operation the throughput shall be measured for relevant carriers specified by the test configuration in ETSI TS 136 141 [11], clause 4.10.
- 4) Interchange the connections of the CGC RX ports and repeat the measurements according to steps 1) to 3).

For each measured E-UTRA carrier, the results obtained shall be compared to the limits in clause 8.2.8.2 in order to prove compliance.

9.3.8 Receiver intermodulation characteristics

9.3.8.0 General

For an E-UTRA Wide Area CGC additionally conforming to ETSI EN 301 908-18 [16], either the test suite of the present clause or the Receiver intermodulation test suite in clause 5.3.9 of ETSI EN 301 908-18 [16] can be equally applied, as listed in table 45.

9.3.8.1 Initial conditions

Test environment: normal, see ETSI TS 136 141 [11], clause D.2.

RF channels to be tested: B, M and T, see clause 9.1.

RF bandwidth position to be tested: B_{RFBW} and T_{RFBW} ; see clause 9.1.

- 1) Set-up the measurement system as shown in ETSI TS 136 141 [11], clause I.2.7.

9.3.8.2 Procedures

- 1) Generate the wanted signal and adjust the signal level to the CGC under test to the level specified in table 57.
- 2) Adjust the signal generators to the type of interfering signals, levels and the frequency offsets as specified in tables 57 and 58 for intermodulation requirement, table 59 for Wide Area CGC narrowband intermodulation requirement, table 60 for Local Area CGC narrowband intermodulation requirement.
- 3) Measure the throughput according to ETSI TS 136 141 [11], annex E, for multi-carrier operation the throughput shall be measured for relevant carriers specified by the test configuration in ETSI TS 136 141 [11], clause 4.10.
- 4) Repeat the whole test for the port which was terminated.

For each measured E-UTRA carrier, the results obtained shall be compared to the limits in clause 8.2.9.2 in order to prove compliance.

9.3.9 Adjacent Channel Selectivity (ACS) and narrow-band blocking

9.3.9.0 General

For an E-UTRA Wide Area CGC additionally conforming to ETSI EN 301 908-18 [16], either the test suite of the present clause or the Narrowband blocking test suite in clause 5.3.10 of ETSI EN 301 908-18 [16] can be equally applied, as listed in table 45.

9.3.9.1 Initial conditions

Test environment: normal, see ETSI TS 136 141 [11], clause D.2.

RF channels to be tested: B, M and T, see clause 9.1.

RF bandwidth position to be tested: M_{RFBW} , see clause 9.1.

- 1) Set-up the measurement system as shown in ETSI TS 136 141 [11], clause I.2.4.

9.3.9.2 Procedure for Adjacent Channel Selectivity

- 1) Generate the wanted signal and adjust the input level to the CGC under test to the level specified in table 63 for Wide Area CGC, in table 64 for Local Area CGC.
- 2) Set-up the interfering signal at the adjacent channel frequency and adjust the interfering signal level at the CGC input to the level defined in table 63 for Wide Area CGC, in table 64 for Local Area CGC.
- 3) Measure the throughput according to ETSI TS 136 141 [11], annex E, for multi-carrier operation the throughput shall be measured for relevant carriers specified by the test configuration in ETSI TS 136 141 [11], clause 4.10.

- 4) Repeat the test for the port, which was terminated.

9.3.9.3 Procedure for narrow-band blocking

- 1) For FDD CGC start CGC transmission according to E-TM1.1 in ETSI TS 136 141 [11]. at P_{max} , for multi-carrier operation start CGC transmission according to applicable test configuration in clause 4.10 of ETSI TS 136 141 [11]. with the same carrier locations used for the wanted signal with the sum of the carrier powers equal to P_{max} .
- 2) Generate the wanted signal and adjust the input level to the CGC under test to the level specified in table 61.
- 3) Adjust the interfering signal level at the CGC input to the level defined in table 61. Set-up and sweep the interfering RB centre frequency offset to the channel edge of the wanted signal according to table 62.
- 4) Measure the throughput according to ETSI TS 136 141 [11], annex E, for multi-carrier operation the throughput shall be measured for relevant carriers specified by the test configuration in ETSI TS 136 141 [11], clause 4.10.
- 5) Repeat the test for the port, which was terminated.

For each measured E-UTRA carrier, the results obtained shall be compared to the limits in clause 8.2.10.2 in order to prove compliance.

Annex A (normative): Relationship between the present document and the essential requirements of Directive 2014/53/EU

The present document has been prepared under the Commission's standardisation request C(2015) 5376 final [i.9] to provide one voluntary means of conforming to the essential requirements of Directive 2014/53/EU on the harmonisation of the laws of the Member States relating to the making available on the market of radio equipment and repealing Directive 1999/5/EC [13].

The present document is therefore intended to cover the provisions of Directive 2014/53/EU [13] (RE Directive) article 3.2 which states that "*Radio equipment shall be so constructed that it both effectively uses and supports the efficient use of radio spectrum in order to avoid harmful interference*".

Recital 10 of Directive 2014/53/EU [13] states that "*In order to ensure that radio equipment uses the radio spectrum effectively and supports the efficient use of radio spectrum, radio equipment should be constructed so that: in the case of a transmitter, when the transmitter is properly installed, maintained and used for its intended purpose it generates radio waves emissions that do not create harmful interference, while unwanted radio waves emissions generated by the transmitter (e.g. in adjacent channels) with a potential negative impact on the goals of radio spectrum policy should be limited to such a level that, according to the state of the art, harmful interference is avoided; and, in the case of a receiver, it has a level of performance that allows it to operate as intended and protects it against the risk of harmful interference, in particular from shared or adjacent channels, and, in so doing, supports improvements in the efficient use of shared or adjacent channels*".

Recital 11 of Directive 2014/53/EU [13] states that "*Although receivers do not themselves cause harmful interference, reception capabilities are an increasingly important factor in ensuring the efficient use of radio spectrum by way of an increased resilience of receivers against harmful interference and unwanted signals on the basis of the relevant essential requirements of Union harmonisation legislation*".

As a consequence, the present document includes both transmitting and receiving parameters to maximize the efficient use of radio spectrum.

Once the present document is cited in the Official Journal of the European Union under that Directive, compliance with the normative clauses of the present document given in table A.1 confers, within the limits of the scope of the present document, a presumption of conformity with the corresponding essential requirements of that Directive, and associated EFTA regulations.

**Table A.1: Relationship between the present document and
the essential requirements of Directive 2014/53/EU**

Harmonised Standard ETSI EN 302 574-1						
The following requirements are relevant to the presumption of conformity under the article 3.2 of Directive 2014/53/EU [13]						
Requirement					Requirement Conditionality	
No	Description	Reference: Clause No			U/C	Condition
		Conventional CGC	Aeronautical CGC	Conventional CGC E-UTRA		
1	Spectrum emission mask	4.2.2	5.2.2	8.2.2	U	
2	Adjacent Channel Leakage ratio (ACLR)	4.2.3	5.2.3	8.2.3	U	
3	Transmitter spurious emission	4.2.4	5.2.4	8.2.4	U	
4	CGC Maximum output power	4.2.5	5.2.5	8.2.5	U	
5	Transmit intermodulation	4.2.6	5.2.6	8.2.6	U	
6	Receiver spurious emission	4.2.7	5.2.7	8.2.7	U	
7	Blocking characteristics	4.2.8	5.2.8	8.2.8	U	

Harmonised Standard ETSI EN 302 574-1						
The following requirements are relevant to the presumption of conformity under the article 3.2 of Directive 2014/53/EU [13]						
Requirement					Requirement Conditionality	
No	Description	Reference: Clause No			U/C	Condition
		Conventional CGC	Aeronautical CGC	Conventional CGC E-UTRA		
8	Receiver intermodulation characteristics	4.2.9	5.2.9	8.2.9	U	
9	Receiver Adjacent Channel Selectivity (ACS)	4.2.10	5.2.10	8.2.10	U	

Key to columns:**Requirement:**

No A unique identifier for one row of the table which may be used to identify a requirement.

Description A textual reference to the requirement.

Clause Number Identification of clause(s) defining the requirement in the present document unless another document is referenced explicitly.

Requirement Conditionality:

U/C Indicates whether the requirement shall be unconditionally applicable (U) or is conditional upon the manufacturers claimed functionality of the equipment (C).

Condition Explains the conditions when the requirement shall or shall not be applicable for a requirement which is classified "conditional".

Presumption of conformity stays valid only as long as a reference to the present document is maintained in the list published in the Official Journal of the European Union. Users of the present document should consult frequently the latest list published in the Official Journal of the European Union.

Other Union legislation may be applicable to the product(s) falling within the scope of the present document.

Annex B (normative): Complementary Ground Component configurations

B.1 Receiver diversity

For the tests in clauses 6 and 7, the specified test signals shall be applied to one receiver antenna connector, with the remaining receivers are disabled or their antenna connectors being terminated with.

B.2 Duplexers

The requirements of the present document shall be met with a duplexer fitted, if a duplexer is supplied as part of the CGC. If the duplexer is supplied as an option by the manufacturer, sufficient tests should be repeated with and without the duplexer fitted to verify that the CGC meets the requirements of the present document in both cases.

The following tests should be performed with the duplexer fitted, and without it fitted if this is an option:

- 1) Clauses 5.3.4, 7.3.4 and 9.3.4, CGC maximum output power, for the highest static power step only, if this is measured at the antenna connector.
- 2) Clauses 5.3.3, 7.3.3 and 9.3.3, output RF spectrum emissions; outside the CGC transmit band.
- 3) Clauses 5.3.5, 7.3.5 and 9.3.5, transmit intermodulation; for the testing of conformance, the carrier frequencies should be selected to minimize intermodulation products from the transmitters falling in receive channels. The remaining tests may be performed with or without the duplexer fitted.

NOTE 1: When performing receiver tests with a duplexer fitted, it is important to ensure that the output from the transmitters does not affect the test apparatus. This can be achieved using a combination of attenuators, isolators and filters.

NOTE 2: When duplexers are used, intermodulation products will be generated, not only in the duplexer but also in the antenna system. The intermodulation products generated in the antenna system are not controlled by the specifications, and may degrade during operation (e.g. due to moisture ingress). Therefore, to ensure continued satisfactory operation of a CGC, an operator will normally select channels to minimize intermodulation products falling on receive channels. For testing of complete conformance, an operator may specify the channels to be used.

B.3 Splitters

The requirements of the present document shall be met with a splitter fitted, if a splitter is supplied as part of the CGC. If the splitter is supplied as an option by the manufacturer, sufficient tests should be repeated with and without the splitter fitted to verify that the CGC meets the requirements of the present document in both cases.

When a splitter is supplied as part of the CGC, the test signal shall be measured at each output of the splitter.

The following tests should be performed with the splitter fitted, and without it fitted if this is an option:

- 1) Clauses 5.3.4, 7.3.4 and 9.3.4, CGC maximum output power, for the highest static power step only, if this is measured at the antenna connector.
- 2) Clauses 5.3.1, 7.3.1 and 9.3.1, Spectrum emission mask.
- 3) Clauses 5.3.3, 7.3.3 and 9.3.3, output RF spectrum emissions; outside the CGC transmit band.
- 4) Clauses 5.3.5, 7.3.5 and 9.3.5, transmit intermodulation; for the testing of conformance, the carrier frequencies should be selected to minimize intermodulation products from the transmitters falling in receive channels. The remaining tests may be performed with or without the duplexer fitted.

NOTE: When performing receiver tests with a duplexer fitted, it is important to ensure that the output from the transmitters does not affect the test apparatus. This can be achieved using a combination of attenuators, isolators and filters.

B.4 Power supply options

If the CGC is supplied with a number of different power supply configurations, it may not be necessary to test RF parameters for each of the power supply options, provided that it can be demonstrated that the range of conditions over which the equipment is tested is at least as great as the range of conditions due to any of the power supply configurations.

This applies particularly if a CGC contains a DC rail which can be supplied either externally or from an internal mains power supply. In this case, the conditions of extreme power supply for the mains power supply options can be tested by testing only the external DC supply option. The range of DC input voltages for the test should be sufficient to verify the performance with any of the power supplies, over its range of operating conditions within the CGC, including variation of mains input voltage, temperature and output current.

B.5 Ancillary RF amplifiers

This clause applies to a CGC which incorporates an ancillary amplifier.

The ancillary amplifier is incorporated into the CGC by a connecting network (including any cable(s), attenuator(s), etc.) with applicable loss to make sure the appropriate operating conditions of complete CGC including the ancillary amplifier. The applicable connecting network loss range is declared by the manufacturer. Other characteristics and the temperature dependence of the attenuation of the connecting network are neglected. The actual attenuation value of the connecting network is chosen for each test as one of the applicable extreme values. The lowest value is used unless otherwise stated.

Sufficient tests should be repeated with the ancillary amplifier fitted and, if it is optional, without the ancillary RF amplifier to verify that the CGC meets the requirements of the present document in both cases.

When testing, the following tests should be repeated with the optional ancillary amplifier fitted according to table B.1, where x denotes that the test is applicable.

Table B.1: Table of tests applicable to Ancillary RF Amplifiers

	Clause	Tx amplifier only	Rx amplifier only	Tx/Rx amplifiers combined (see note)
Receiver Tests	5.3.7, 7.3.7 and 9.3.7			
	5.3.8, 7.3.8 and 9.3.8			
	5.3.6, 7.3.6 and 9.3.6			
Transmitter Tests	5.3.4, 7.3.4 and 9.3.4	X		X
	5.3.3, 7.3.3 and 9.3.3	X		X
	5.3.5, 7.3.5 and 9.3.5	X		X
NOTE: Combining can be by duplex filters or any other network. The amplifiers can either be in Rx or Tx branch or in both. Either one of these amplifiers could be a passive network.				

In tests according to clauses 5.3.4 for conventional CGC and 7.3.4 for aeronautical CGC, the highest applicable attenuation value is applied.

B.6 CGC using antenna arrays

B.6.0 General

This clause applies to CGC that incorporate antenna arrays.

A CGC may be configured with a multiple antenna port connection for some or all of its transceivers or with an antenna array related to one sector (not one array per transceiver). This clause applies to a CGC which meets at least one of the following conditions:

- the transmitter output signals from one or more transceiver appear at more than one antenna port per sector in the case of sectorized CGC; or
- there is more than one receiver antenna port for a transceiver or per cell and an input signal is required at more than one port for the correct operation of the receiver thus the outputs from the transmitters as well as the inputs to the receivers are directly connected to several antennas (known as "air combining"); or
- transmitters and receivers are connected via duplexers to more than one antenna.

NOTE: Diversity reception does not meet this requirement.

In case of diversity, main and diversity antenna are not considered as an antenna array.

If a CGC is used, in normal operation, in conjunction with an antenna system which contains filters or active elements which are necessary to meet the requirements, the conformance tests may be performed on a system comprising the CGC together with these elements, supplied separately for the purposes of testing. In this case, it shall be demonstrated that the performance of the configuration under test is representative of the system in normal operation, and the conformance assessment is only applicable when the CGC is used with the antenna system.

For conformance testing of such a CGC, the following procedure may be used.

B.6.1 Receiver tests

Power of the signals applied is equal to the power of the test signal(s) specified in the test.

An example of a suitable test configuration is shown in figure B.1.

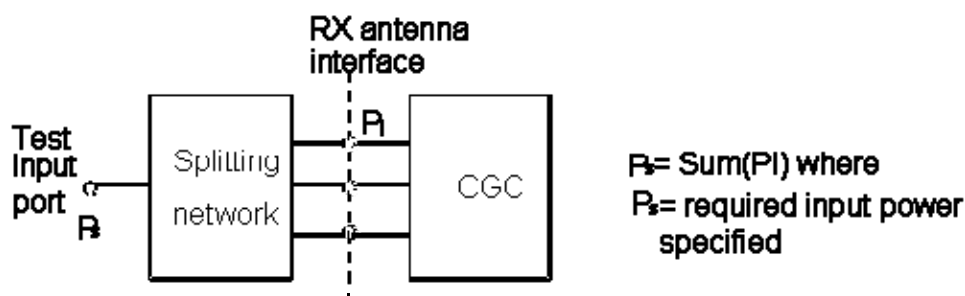

Figure B.1: Receiver test set-up

For spurious emissions from the receiver antenna connector, the test may be performed separately for each receiver antenna connector.

B.6.2 Transmitter tests

For each test, the test signals applied to the transmitter antenna connectors (P_i) shall be such that the sum of the powers of the signals applied equals the power of the test signal(s) (P_T) specified in the test. This may be assessed by separately measuring the signals emitted by each antenna connector and summing the results, or by combining the signals and performing a single measurement. The characteristics (e.g. amplitude and phase) of the combining network should be such that the power of the combined signal is maximized.

An example of a suitable test configuration is shown in figure B.2.

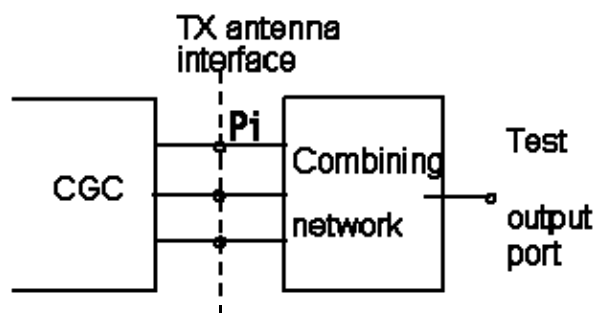

Figure B.2: Transmitter test set-up

B.7 Transmit diversity

Unless otherwise stated, for the tests in clause 6 or clause 7 of the present document, the signal shall be measured at both main and diversity transmitters antenna connectors, with the remaining antenna connector being terminated.

B.8 CGC with integrated Iuant CGC modem

Unless otherwise stated, for the tests in the present document, the integrated Iuant CGC modem shall be switched off. Spurious emissions according to clauses 5.3.3 or 7.3.3 or 9.3.3 shall be measured only for frequencies above $4 \times \text{CBw}$ with the integrated Iuant CGC modem switched on.

B.9 Combining of CGCs

If the CGC is intended for combination with additional apparatus connected to a CGC port and this combination is supplied as a system, the combination of CGC together with the additional apparatus shall also fulfil the CGC requirements. E.g. if the CGC is intended for combination such that multiple CGCs amplify the same signals into the same ports the combination shall also fulfil the CGC requirements.

An example of such a configuration is shown in figure B.3.

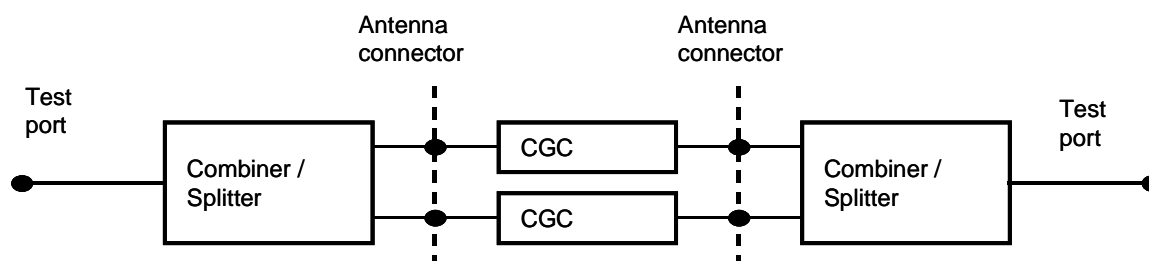

Figure B.3: Example of CGC configuration

Annex C (informative): Environmental profile specification

C.0 General

The following environmental conditions may be declared by the supplier :

- barometric pressure: minimum and maximum;
- temperature: minimum and maximum;
- relative humidity: minimum and maximum;
- power supply: lower and upper voltage limit.

When operating outside the boundary limits of the declared operational environmental profile the equipment should not make ineffective use of the radio frequency spectrum so as to cause harmful interference.

C.1 Tests environment

C.1.1 Measurement of test environments

The measurement accuracy of the CGC normal test environments should be:

Pressure:	±5 kPa.
Temperature:	±2 degrees.
Relative Humidity:	±5 %.
DC Voltage:	±1,0 %.
AC Voltage:	±1,5 %.
Vibration:	10 %.
Vibration frequency:	0,1 Hz.

The above values should apply unless the test environment is otherwise controlled and the specification for the control of the test environment specifies the uncertainty for the parameter.

For each test in the present document, the environmental conditions under which the CGC is to be tested are defined.

C.1.2 Normal test Environment

When a normal test environment is specified for a test, the test should be performed within the minimum and maximum limits of the conditions stated in table C.1.

Table C.1: Limits of conditions for Normal Test Environment

Condition	Minimum	Maximum
Barometric pressure	86 kPa	106 kPa
Temperature	15 °C	30 °C
Relative Humidity	20 %	85 %
Power supply	Nominal, as declared by the manufacturer	
Vibration	Negligible	

The ranges of barometric pressure, temperature and humidity represent the maximum variation expected in the uncontrolled environment of a test laboratory. If it is not possible to maintain these parameters within the specified limits, the actual values should be recorded in the test report.

NOTE: This may, for instance, be the case for measurements of radiated emissions performed on an open field test site.

C.1.3 Extreme test environment

The manufacturer should declare one of the following:

- 1) the equipment class for the equipment under test, as defined in the IEC 60721-3-3 [i.7];
- 2) the equipment class for the equipment under test, as defined in the IEC 60721-3-4 [i.8];
- 3) the equipment that does not comply to the mentioned classes, the relevant classes from IEC 60721-3-3 [i.7] and IEC 60721-3-4 [i.8] documentation for Temperature, Humidity and Vibration should be declared.

NOTE: Reduced functionality for conditions that fall outside of the standard operational conditions is not tested in the present document. These may be stated and tested separately.

C.1.4 Extreme temperature

When an extreme temperature test environment is specified for a test, the test should be performed at the standard minimum and maximum operating temperatures defined by the manufacturers' declaration for the equipment under test.

Minimum temperature:

The test should be performed with the environment test equipment and methods including the required environmental phenomena into the equipment, conforming to the test procedure of IEC 60068-2-1 [7].

Maximum temperature:

The test should be performed with the environmental test equipment and methods including the required environmental phenomena into the equipment, conforming to the test procedure of IEC 60068-2-2 [8].

NOTE: It is recommended that the equipment is made fully operational prior to the equipment being taken to its lower operating temperature.

C.1.5 Vibration

When vibration conditions are specified for a test, the test should be performed while the equipment is subjected to a vibration sequence as defined by the manufacturer's declaration for the equipment under test. This should use the environmental test equipment and methods of inducing the required environmental phenomena in to the equipment, conforming to the test procedure of IEC 60068-2-6 [9]. Other environmental conditions should be within the ranges specified in clause C.1.2.

NOTE: The higher levels of vibration may induce undue physical stress in to equipment after a prolonged series of tests. The testing body should only vibrate the equipment during the RF measurement process.

C.1.6 Power supply

When extreme power supply conditions are specified for a test, the test should be performed at the standard upper and lower limits of operating voltage defined by manufacturer's declaration for the equipment under test.

Upper voltage limit:

The equipment should be supplied with a voltage equal to the upper limit declared by the manufacturer (as measured at the input terminals to the equipment). The tests should be carried out at the steady state minimum and maximum temperature limits declared by the manufacturer for the equipment, to the methods described in IEC 60068-2-1 [7] Test Ab/Ad and IEC 60068-2-2 [8] Test Bb/Bd: Dry Heat.

Lower voltage limit:

The equipment should be supplied with a voltage equal to the lower limit declared by the manufacturer (as measured at the input terminals to the equipment). The tests should be carried out at the steady state minimum and maximum temperature limits declared by the manufacturer for the equipment, to the methods described in IEC 60068-2-1 [7] Test Ab/Ad and IEC60 068-2-2 [8] Test Bb/Bd: Dry Heat.

C.1.7 Definition of Additive White Gaussian Noise (AWGN) Interferer

The minimum bandwidth of the AWGN interferer should be 1,5 times symbol rate of the radio access mode. (e.g. 5,76 MHz for a chip rate of 3,84 Mcps). The flatness across this minimum bandwidth should be less than $\pm 0,5$ dB and the peak to average ratio at a probability of 0,001 % should exceed 10 dB.

Annex D (informative): Measurement system set-up

D.0 General

Example of measurement system set-ups are attached below as an informative annex.

The block diagram of the measurement set-up for the maximum output power testing is shown in figure D.1.

The block diagram of the measurement set-up for the out of band emission testing is shown in figure D.2.

The block diagram of the measurement set-up for the transmit intermodulation testing is shown in figure D.3.

D.1 Transmitter

D.1.1 Maximum output power



Figure D.1: Measuring system Set-up for maximum output power, total power dynamic range

D.1.2 Out of band emission

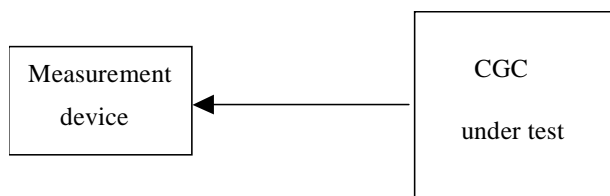

Figure D.2: Measuring system Set-up for Out of band emission measurements

The measurement device is used to measure out of band emission.

D.1.3 Transmit intermodulation

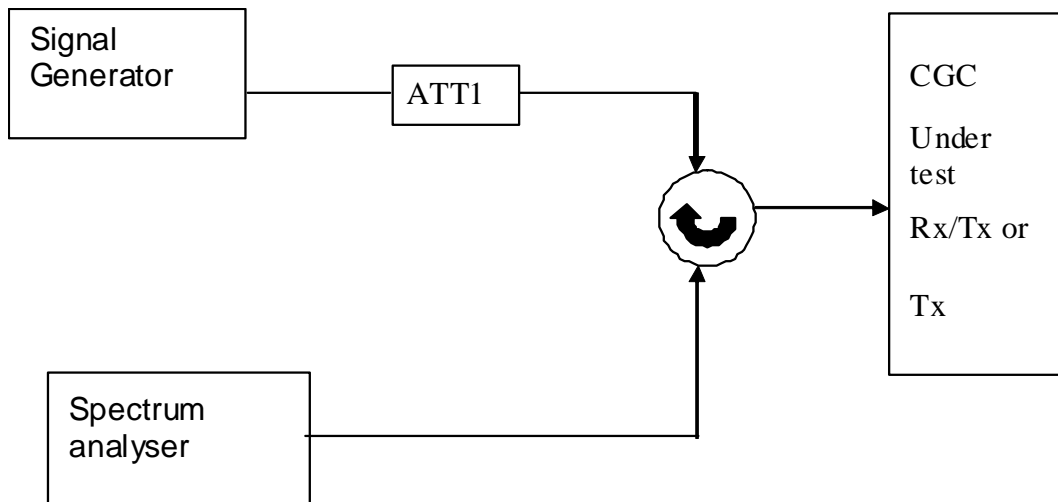

Figure D.3: Measuring system Set-up for CGC Transmit Intermodulation Tests

D.2 Receiver

D.2.1 Adjacent Channel Selectivity (ACS)

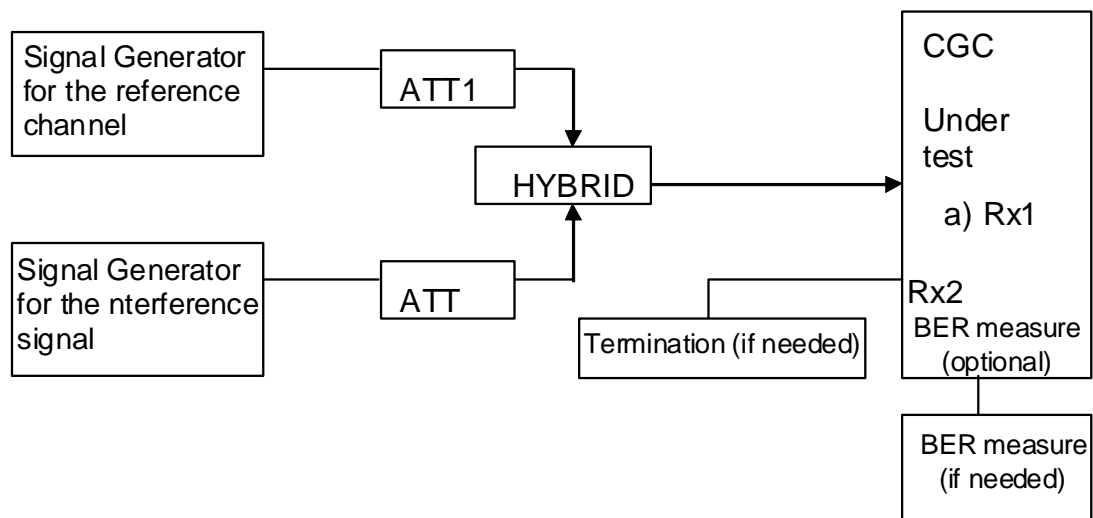

Figure D.4: Measuring system Set-up for Adjacent channel selectivity

D.2.2 Blocking characteristics

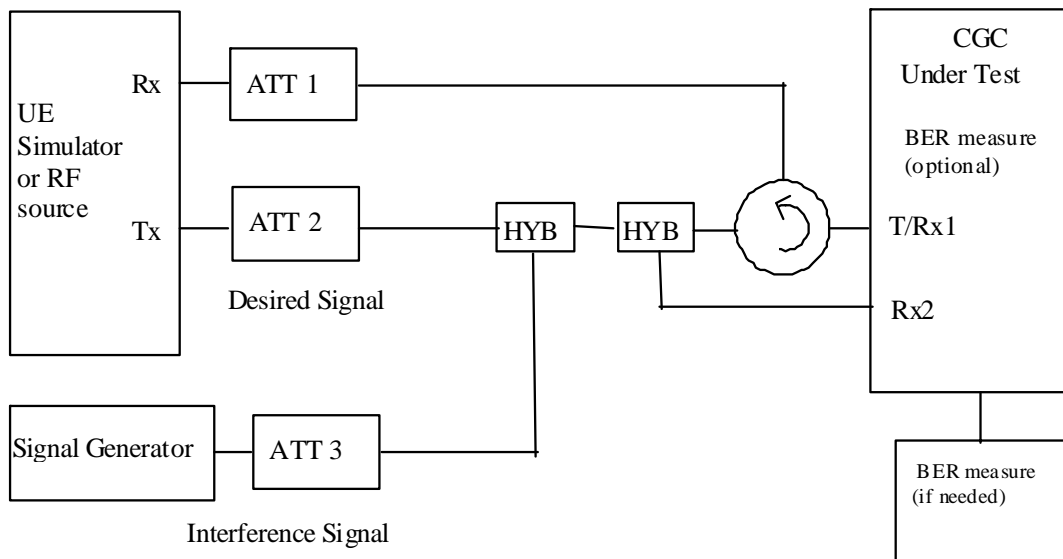

Figure D.5: Measuring system Set-up for Blocking characteristics

D.2.3 Intermodulation characteristics

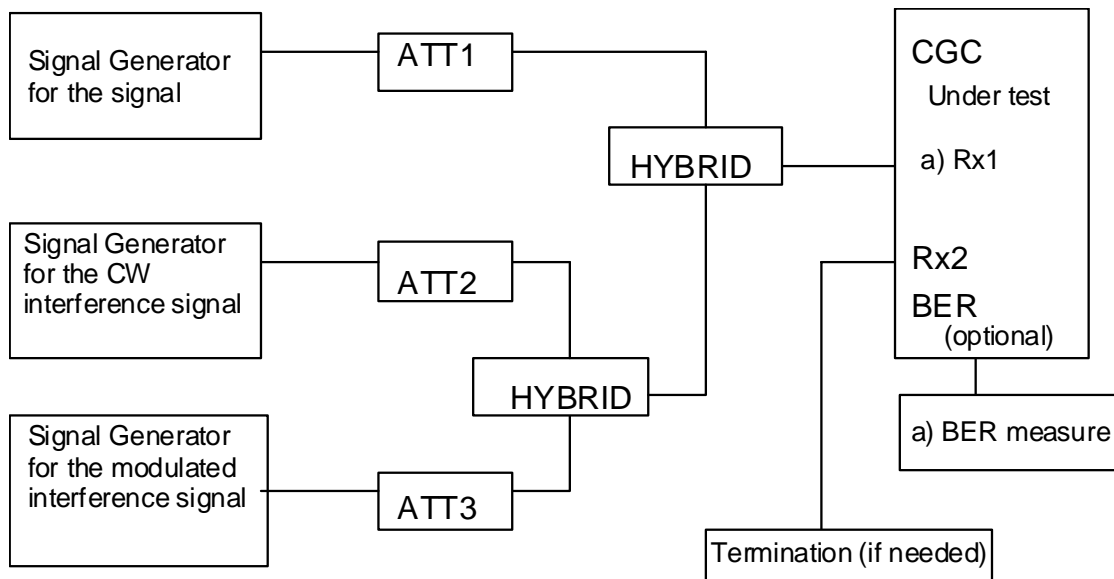

Figure D.6: Measuring system Set-up for intermodulation characteristics

D.2.4 Receiver spurious emission

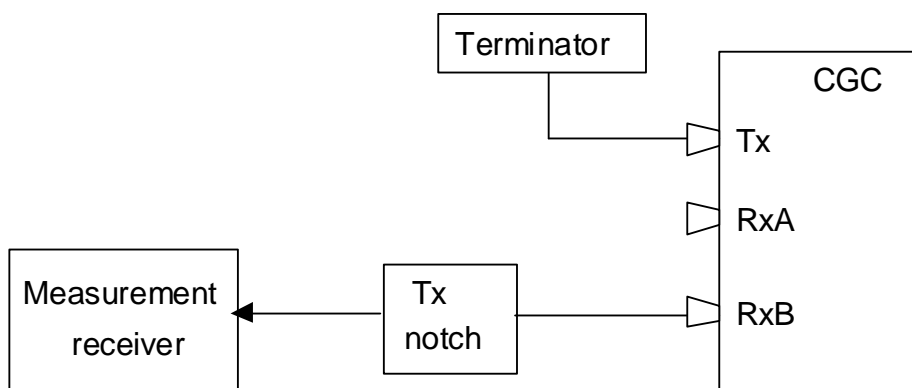

Figure D.7: Measuring system Set-up for Receiver spurious emission

Annex E (informative): Bibliography

- Directive 1999/5/EC of the European Parliament and of the Council of 9 March 1999 on radio equipment and telecommunications terminal equipment and the mutual recognition of their conformity (R&TTE Directive).
- Council Directive 89/336/EEC of 3 May 1989 on the approximation of the laws of the Member States relating to electromagnetic compatibility (EMC Directive).
- Directive 2004/108/EC of the European Parliament and of the Council of 15 December 2004 on the approximation of the laws of the Member States relating to electromagnetic compatibility and repealing Directive 89/336/EEC.
- Council Directive 73/23/EEC of 19 February 1973 on the harmonisation of the laws of Member States relating to electrical equipment designed for use within certain voltage limits (LV Directive).
- Recommendation ITU-R SM.1539: "Variation of the boundary between the out-of-band and spurious domains required for the application of Recommendations ITU-R SM.1541 and Recommendation ITU-R SM.329".
- ECC Report 233 (05-2015): "Adjacent band compatibility studies for aeronautical CGC systems operating in the bands 1980-2010 MHz and 2170-2200 MHz".
- Directive 98/34/EC of the European Parliament and of the Council of 22 June 1998 laying down a procedure for the provision of information in the field of technical standards and regulations.
- ETSI EN 302 574-2: "Satellite Earth Stations and Systems (SES); Harmonised Standard for Satellite Earth Stations (MES) for MSS operating in the 2 GHz frequency bands; Part 2: User Equipment (UE) for wideband systems covering the essential requirements of article 3.2 of the Directive 2014/53/EU".
- ETSI EN 302 574-3: "Satellite Earth Stations and Systems (SES); Harmonised Standard for Satellite Earth Stations (MES) for MSS operating in the 1 980 MHz to 2 010 MHz (earth-to-space) and 2 170 MHz to 2 200 MHz (space-to-earth) frequency bands; Part 3: User Equipment (UE) for narrowband systems covering the essential requirements of article 3.2 of the Directive 2014/53/EU".

History

Document history		
V1.1.1	August 2010	Publication
V2.1.0	March 2016	EN Approval Procedure AP 20160530: 2016-03-01 to 2016-05-30