

Final draft **ETSI EN 302 571** V1.1.1 (2008-07)

Harmonized European Standard (Telecommunications series)

**Intelligent Transport Systems (ITS);
Radiocommunications equipment operating
in the 5 855 MHz to 5 925 MHz frequency band;
Harmonized EN covering the essential requirements
of article 3.2 of the R&TTE Directive**



Reference

DEN/ERM-TG37-007

Keywords

CALM, ITS, radio, regulation, transport

ETSI

650 Route des Lucioles
F-06921 Sophia Antipolis Cedex - FRANCE

Tel.: +33 4 92 94 42 00 Fax: +33 4 93 65 47 16

Siret N° 348 623 562 00017 - NAF 742 C
Association à but non lucratif enregistrée à la
Sous-Préfecture de Grasse (06) N° 7803/88

Important notice

Individual copies of the present document can be downloaded from:

<http://www.etsi.org>

The present document may be made available in more than one electronic version or in print. In any case of existing or perceived difference in contents between such versions, the reference version is the Portable Document Format (PDF). In case of dispute, the reference shall be the printing on ETSI printers of the PDF version kept on a specific network drive within ETSI Secretariat.

Users of the present document should be aware that the document may be subject to revision or change of status. Information on the current status of this and other ETSI documents is available at

<http://portal.etsi.org/tb/status/status.asp>

If you find errors in the present document, please send your comment to one of the following services:

http://portal.etsi.org/chaicor/ETSI_support.asp

Copyright Notification

No part may be reproduced except as authorized by written permission.
The copyright and the foregoing restriction extend to reproduction in all media.

© European Telecommunications Standards Institute 2008.
All rights reserved.

DECT™, PLUGTESTS™, UMTS™, TIPHON™, the TIPHON logo and the ETSI logo are Trade Marks of ETSI registered for the benefit of its Members.

3GPP™ is a Trade Mark of ETSI registered for the benefit of its Members and of the 3GPP Organizational Partners.

Contents

Intellectual Property Rights	6
Foreword.....	6
Introduction	6
1 Scope	7
2 References	7
2.1 Normative references	8
2.2 Informative references.....	8
3 Definitions, symbols and abbreviations	8
3.1 Definitions	8
3.2 Symbols.....	9
3.3 Abbreviations	9
4 General	10
4.1 Presentation of equipment for testing purposes.....	10
4.1.1 Choice of model for testing	10
4.1.1.1 Auxiliary test equipment.....	10
4.1.1.2 Declarations by the provider	10
4.2 Mechanical and electrical design.....	11
4.2.1 General.....	11
4.2.2 Controls	11
4.3 Testing using bit streams or messages.....	11
4.4 Measuring continuous mode equipment.....	11
4.5 Measuring discontinuous mode equipment	11
5 Test conditions, power sources and ambient temperatures	11
5.1 Normal and extreme test conditions	11
5.2 Test power source.....	11
5.3 Normal test conditions.....	12
5.3.1 Normal temperature and humidity	12
5.3.2 Normal test power source	12
5.3.2.1 Mains voltage.....	12
5.3.2.2 Regulated lead-acid battery power sources used on vehicles.....	12
5.3.2.3 Other power sources.....	12
5.4 Extreme test conditions	12
5.4.1 Extreme temperatures	12
5.4.2 Extreme test source voltages.....	12
5.4.2.1 Mains voltage.....	12
5.4.2.2 Regulated lead-acid battery power sources used on vehicles.....	13
5.4.2.3 Power sources using other types of batteries.....	13
5.4.2.4 Other power sources.....	13
5.5 Procedure for tests at extreme temperatures.....	13
5.5.1 Procedure for equipment designed for continuous transmission.....	13
5.5.2 Procedure for equipment designed for intermittent transmission	14
5.5.3 Testing of equipment that does not have an external 50 Ω RF connector (integral antenna equipment).....	14
6 Technical requirements specifications	14
6.1 Environmental profile.....	14
6.2 Carrier Frequencies	14
6.2.1 Definition.....	14
6.2.2 Limits.....	15
6.2.3 Conformance.....	15
6.3 RF Output Power, Transmit Power Control (TPC) and Power Spectral Density (PSD)	15
6.3.1 Definitions	15
6.3.1.1 RF output power.....	15

6.3.1.2	Transmit Power Control	15
6.3.1.3	Power Spectral Density	15
6.3.2	Limits	15
6.3.2.1	Total RF output power and power spectral density at the highest power level	15
6.3.2.2	Total RF output power and power spectral density at the lowest power level	16
6.3.3	Conformance	16
6.4	Transmitter unwanted emissions	16
6.4.1	Transmitter unwanted emissions outside the 5 GHz ITS frequency bands	16
6.4.1.1	Definition	16
6.4.1.2	Limits	16
6.4.1.3	Conformance	16
6.4.2	Transmitter unwanted emissions within the 5 GHz ITS frequency bands	17
6.4.2.1	Definition	17
6.4.2.2	Limits	17
6.4.2.3	Conformance	17
6.5	Receiver spurious emissions	17
6.5.1	Definition	17
6.5.2	Limits	18
6.5.3	Conformance	18
6.6	Listen Before Talk threshold	18
6.6.1	Definitions	18
6.6.2	Limits	18
6.6.3	Conformance	18
6.7	Receiver blocking or desensitization	19
6.7.1	Definition	19
6.7.2	Limits	19
6.7.3	Conformance	19
7	Testing for compliance with technical requirements	19
7.1	Conditions for testing	19
7.1.1	Normal and extreme test conditions	19
7.1.2	Test modulation	19
7.1.3	Presentation of equipment	19
7.2	Interpretation of the measurement results	20
7.3	Essential radio test suites	20
7.3.1	Product information	20
7.3.2	Carrier Frequencies	21
7.3.2.1	Test conditions	21
7.3.2.2	Test methods	21
7.3.2.2.1	Conducted measurement	21
7.3.2.2.2	Radiated measurement	21
7.3.3	RF Output Power, Transmit Power Control (TPC) and Power Spectral Density (PSD)	21
7.3.3.1	Test conditions	21
7.3.3.2	Test method	22
7.3.3.2.1	Conducted measurement	22
7.3.3.2.2	Radiated measurement	24
7.3.4	Transmitter unwanted emissions outside the 5 GHz ITS bands	24
7.3.4.1	Test conditions	24
7.3.4.2	Test method	25
7.3.4.2.1	Conducted measurement	25
7.3.4.2.2	Radiated measurement	25
7.3.5	Transmitter unwanted emissions within the 5 GHz ITS bands	26
7.3.5.1	Test conditions	26
7.3.5.2	Test method	26
7.3.5.2.1	Conducted measurement	26
7.3.5.2.2	Radiated measurement	27
7.3.6	Receiver spurious emissions	27
7.3.6.1	Test conditions	27
7.3.6.2	Test method	27
7.3.6.2.1	Conducted measurement	27
7.3.6.2.2	Radiated measurement	28
7.3.7	Receiver LBT threshold	28

7.3.7.1	Test conditions	28
7.3.7.2	Test method.....	28
7.3.8	Receiver blocking or desensitization	28
7.3.8.1	Test conditions	28
7.3.8.2	Test method.....	29
Annex A (normative):	HS Requirements and conformance Test specifications Table (HS-RTT).....	30
Annex B (normative):	Test sites and arrangements for radiated measurements.....	32
B.1	Test sites.....	32
B.1.1	Open air test sites	32
B.1.2	Anechoic chamber.....	33
B.1.2.1	General.....	33
B.1.2.2	Description.....	33
B.1.2.3	Influence of parasitic reflections.....	33
B.1.2.4	Calibration and mode of use	34
B.2	Test antenna.....	35
B.3	Substitution antenna	36
Annex C (normative):	General description of measurement	37
C.1	Conducted measurements.....	37
C.2	Radiated measurements.....	37
C.3	Substitution measurement	38
Annex D (informative):	The EN title in the official languages	39
Annex E (informative):	Bibliography.....	40
History		41

Intellectual Property Rights

IPRs essential or potentially essential to the present document may have been declared to ETSI. The information pertaining to these essential IPRs, if any, is publicly available for **ETSI members and non-members**, and can be found in ETSI SR 000 314: "*Intellectual Property Rights (IPRs); Essential, or potentially Essential, IPRs notified to ETSI in respect of ETSI standards*", which is available from the ETSI Secretariat. Latest updates are available on the ETSI Web server (<http://webapp.etsi.org/IPR/home.asp>).

Pursuant to the ETSI IPR Policy, no investigation, including IPR searches, has been carried out by ETSI. No guarantee can be given as to the existence of other IPRs not referenced in ETSI SR 000 314 (or the updates on the ETSI Web server) which are, or may be, or may become, essential to the present document.

Foreword

This Harmonized European Standard (Telecommunications series) has been produced by ETSI Technical Committee Electromagnetic compatibility and Radio spectrum Matters (ERM), and is now submitted for the Vote phase of the ETSI standards Two-step Approval Procedure.

The present document has been produced by ETSI in response to a mandate from the European Commission issued under Council Directive 98/34/EC (as amended) [i.1] laying down a procedure for the provision of information in the field of technical standards and regulations.

The present document is intended to become a Harmonized Standard, the reference of which will be published in the Official Journal of the European Communities referencing the Directive 1999/5/EC of the European Parliament and of the Council of 9 March 1999 on radio equipment and telecommunications terminal equipment and the mutual recognition of their conformity ("the R&TTE Directive") [i.2].

Technical specifications relevant to Directive 1999/5/EC [i.2] are given in annex A.

Equipment compliant with the present document can be intended for fitment into road vehicles, therefore it is subject to automotive EMC type approval and Directive 95/54/EC [i.3]. For use on vehicles outside the scope of Directive 95/54/EC [i.3], compliance with an EMC directive/standard appropriate for that use is required.

Proposed national transposition dates	
Date of latest announcement of this EN (doa):	3 months after ETSI publication
Date of latest publication of new National Standard or endorsement of this EN (dop/e):	6 months after doa
Date of withdrawal of any conflicting National Standard (dow):	18 months after doa

Introduction

The present document is part of a set of standards developed by ETSI and is designed to fit in a modular structure to cover all radio and telecommunications terminal equipment within the scope of the R&TTE Directive. The modular structure is shown in EG 201 399 [i.4].

1 Scope

The present document applies to communications using radio transmitters and receivers for Intelligent Transport Systems (ITS). ITS communications may comprise vehicle-to-vehicle, vehicle-to-roadside and roadside-to-vehicle.

Table 1: Radiocommunications service frequency bands

Radiocommunications service frequency bands	
Transmit	5 855 MHz to 5 925 MHz
Receive	5 855 MHz to 5 925 MHz

The equipment is comprised of a transmitter and associated encoder and modulator and/or a receiver and associated demodulator and decoder. The types of equipment covered by the present document are as follows:

- OnBoard Equipment (OBE equipment fitted with an integral or dedicated antenna(s), intended for use in vehicles);
- Road Side Equipment (RSE equipment fitted with an antenna socket, integral or dedicated antenna(s), normally used as a fixed station).

2 References

References are either specific (identified by date of publication and/or edition number or version number) or non-specific.

- For a specific reference, subsequent revisions do not apply.
- Non-specific reference may be made only to a complete document or a part thereof and only in the following cases:
 - if it is accepted that it will be possible to use all future changes of the referenced document for the purposes of the referring document;
 - for informative references.

Referenced documents which are not found to be publicly available in the expected location might be found at <http://docbox.etsi.org/Reference>.

For online referenced documents, information sufficient to identify and locate the source shall be provided. Preferably, the primary source of the referenced document should be cited, in order to ensure traceability. Furthermore, the reference should, as far as possible, remain valid for the expected life of the document. The reference shall include the method of access to the referenced document and the full network address, with the same punctuation and use of upper case and lower case letters.

NOTE: While any hyperlinks included in this clause were valid at the time of publication ETSI cannot guarantee their long term validity.

2.1 Normative references

The following referenced documents are indispensable for the application of the present document. For dated references, only the edition cited applies. For non-specific references, the latest edition of the referenced document (including any amendments) applies.

- [1] ETSI TR 100 028 (2001-12) (all parts): "Electromagnetic compatibility and Radio spectrum Matters (ERM); Uncertainties in the measurement of mobile radio equipment characteristics".
- [2] CISPR 16, (parts 1-1 (2007), 1-4 (2008) and 1-5 (2003)): "Specifications for radio disturbance and immunity measuring apparatus and methods; Part 1: Radio disturbance and immunity measuring apparatus".

2.2 Informative references

The following referenced documents are not essential to the use of the ETSI deliverable but they assist the user with regard to a particular subject area. For non-specific references, the latest version of the referenced document (including any amendments) applies.

- [i.1] Directive 98/34/EC of the European Parliament and of the Council of 22 June 1998 laying down a procedure for the provision of information in the field of technical standards and regulations.
- [i.2] Directive 1999/5/EC of the European Parliament and of the Council of 9 March 1999 on radio equipment and telecommunications terminal equipment and the mutual recognition of their conformity (R&TTE Directive).
- [i.3] Commission Directive 95/54/EC of 31 October 1995 adapting to technical progress Council Directive 72/245/EEC on the approximation of the laws of the Member States relating to the suppression of radio interference produced by spark-ignition engines fitted to motor vehicles and amending Directive 70/156/EEC on the approximation of the laws of the Member States relating to the type-approval of motor vehicles and their trailers.
- [i.4] ETSI EG 201 399 (V2.1.1): "Electromagnetic compatibility and Radio spectrum Matters (ERM); A guide to the production of candidate Harmonized Standards for application under the R&TTE Directive".
- [i.5] ETSI TR 102 070-2 (V1.1.1): "Electromagnetic compatibility and Radio spectrum Matters (ERM); Guide to the application of harmonized standards to multi-radio and combined radio and non-radio equipment; Part 2: Effective use of the radio frequency spectrum".

3 Definitions, symbols and abbreviations

3.1 Definitions

For the purposes of the present document, the following terms and definitions apply:

available channel: channel identified as available for use as an *Operating* Channel having performed a "listen before talk check" first

channel: amount of spectrum used by a single ITS device operating on one of the carrier frequencies listed in table 2 of the present document

dedicated antenna: removable antenna supplied and tested with the radio equipment, designed as an indispensable part of the equipment

NOTE: The dedicated antenna has been designed or developed for one or more specific types of equipment. It is the combination of dedicated antenna and radio equipment that is expected to be compliant with the regulations.

integral antenna: antenna designed as a fixed part of the equipment, without the use of an external connector and as such which can not be disconnected from the equipment by the user

NOTE: An integral antenna may be fitted internally or externally.

Listen Before Talk (LBT): monitoring method in which the RF channel is checked for activity before transmitting

radiated measurements: measurements which involve the absolute measurement of a radiated field

Transmit Power Control (TPC): technique in which the transmitter output power is controlled resulting in reduced interference to other users

Transmit Power Control range: power range over which the TPC is able to control the transmitter output power

3.2 Symbols

For the purposes of the present document, the following symbols apply:

dB	decibel
dBi	antenna gain relative to isotropic radiator in decibel
dBc	decibel relative to carrier power
E	electrical field strength
f	frequency
f_c	nominal centre frequency
G	antenna gain
PH	highest power level
R	distance
T_{max}	maximum temperature
T_{min}	minimum temperature
Tx on	effective transmitter on-time
Tx off	effective transmitter off-time
V_{max}	maximum voltage
V_{min}	minimum voltage
Ω	ohm
μs	microsecond

3.3 Abbreviations

For the purposes of the present document, the following abbreviations apply:

CW	Continuous Wave
DC	Direct Current
e.r.p.	effective radiated power
e.i.r.p.	equivalent isotropically radiated power
EC	European Commission
EMC	Electro Magnetic Compatibility
HS	Harmonized Standard
ITS	Intelligent Transport Systems
LBT	Listen Before Talk
OBE	On Board Equipment
ppm	parts per million = 10^{-6}
PSD	Power Spectral Density
RF	Radio Frequency
RSE	Road Side Equipment
RSU	Road Side Unit
TPC	Transmit Power Control
UUT	Unit Under Test

4 General

4.1 Presentation of equipment for testing purposes

Each equipment submitted for testing shall fulfil the requirements of the present document on all frequencies over which it is intended to operate.

The provider shall declare the frequency ranges, the range of operating conditions and power requirements as applicable, to establish the appropriate test conditions.

Additionally, technical documentation and operating manuals, sufficient to make the test, shall be supplied.

4.1.1 Choice of model for testing

The provider shall provide one or more samples of the equipment, as appropriate for testing.

Stand-alone equipment shall be offered by the provider complete with any ancillary equipment needed for testing.

If an equipment has several optional features considered not to affect the RF parameters, then the tests need only to be performed on the equipment configured with the combination of features considered to be the most complex, as proposed by the provider and agreed by the test laboratory.

If channel bundling as identified in clause 6.2.1 is implemented, then tests need to be performed on the equipment using higher channel bandwidth than 10 MHz. Where practicable, equipment offered for testing shall provide a 50 Ω connector for conducted RF power level measurements.

In the case of a dedicated integral antenna equipment, if the equipment does not have an internal permanent 50 Ω connector, then it is permissible to supply a second sample of the equipment with a temporary antenna connector fitted to facilitate testing.

The performance of the equipment submitted for testing shall be representative of the performance of the corresponding production model.

The equipment may contain digital circuit elements, radio circuit elements and other elements whose performance is not covered by the present document. These elements of the equipment shall meet the appropriate performance requirements for those components, as specified in other standards.

An ITS device which is combined with other system(s) should meet at least the requirements of the present document (for the elements of the device concerned with radio communications), and the requirements of any relevant standard for EMC compatibility of the other equipment for the elements of the device which are not concerned with radio communications.

EXAMPLE: An ITS communications device combined with a navigation system.

NOTE: For further information on this topic see TR 102 070-2 [i.5].

4.1.1.1 Auxiliary test equipment

All necessary test signal sources, setting up instructions and other product information shall accompany the equipment when it is submitted for testing.

4.1.1.2 Declarations by the provider

The provider shall declare the necessary information of the equipment with respect to all technical requirements set by the present document.

4.2 Mechanical and electrical design

4.2.1 General

The equipment shall be designed, constructed and manufactured with the aim of minimizing harmful interference to other equipment and services.

4.2.2 Controls

Those controls, which if maladjusted, might increase the interfering potentialities of the equipment shall not be accessible for adjustment by the user.

4.3 Testing using bit streams or messages

The manufacturer may elect to have the equipment tested using bit streams or data packets.

4.4 Measuring continuous mode equipment

In the case of measurements performed on equipment designed to operate only in continuous mode, requirements such as "equipment shall be set in continuous mode" shall be interpreted as "equipment shall be used in its normal transmission mode (in this case, the continuous mode)".

4.5 Measuring discontinuous mode equipment

When it is specified that the transmission shall be continuous for the duration of the measurement(s), the transmitter under test shall be set to operate in continuous mode. If this is not possible, the measurements shall be carried out in a period shorter than the duration of the transmitted burst. It may be necessary to extend the duration of the burst.

When measurements are made in discontinuous mode, the reported values can be average values. This averaging shall be made using a set of measurements, each of these measurements being made during a burst or a part of it.

5 Test conditions, power sources and ambient temperatures

5.1 Normal and extreme test conditions

Testing shall be made under normal test conditions, and also, where stated, under extreme test conditions.

The test conditions and procedures shall be as specified in clauses 5.2 to 5.5.

5.2 Test power source

During testing the power source of the equipment shall be replaced by a test power source capable of producing normal and extreme test voltages as specified in clauses 5.3.2 and 5.4.2. The internal impedance of the test power source shall be low enough for its effect on the test results to be negligible. For the purpose of tests, the voltage of the power source shall be measured at the input terminals of the equipment.

For battery operated equipment the battery shall be removed and the test power source shall be applied as close to the battery terminals as practicable.

During tests of DC powered equipment the power source voltages shall be maintained within a tolerance of $< \pm 1 \%$ relative to the voltage at the beginning of each test. The value of this tolerance is critical for power measurements, using a smaller tolerance will provide better measurement uncertainty values.

5.3 Normal test conditions

5.3.1 Normal temperature and humidity

The normal temperature and humidity conditions for tests shall be any convenient combination of temperature and humidity within the following ranges:

- temperature: +15 °C to +35 °C;
- relative humidity: 20 % to 75 %.

When it is impracticable to carry out the tests under these conditions, a note to this effect, stating the ambient temperature and relative humidity during the tests, shall be added to the test report.

5.3.2 Normal test power source

5.3.2.1 Mains voltage

The normal test voltage for equipment to be connected to the mains shall be the nominal mains voltage. For the purpose of the present document, the nominal voltage shall be the declared voltage or any of the declared voltages for which the equipment was designed.

The frequency of the test power source corresponding to the ac mains shall be between 49 Hz and 51 Hz.

5.3.2.2 Regulated lead-acid battery power sources used on vehicles

When the radio equipment is intended for operation from the usual types of regulated lead-acid battery power source used on vehicles the normal test voltage shall be 1,1 times the nominal voltage of the battery (e.g. for nominal voltages of 6 V and 12 V, these are 6,6 V and 13,2 V respectively).

5.3.2.3 Other power sources

For operation from other power sources or types of battery (primary or secondary), the normal test voltage shall be that declared by the equipment manufacturer.

5.4 Extreme test conditions

5.4.1 Extreme temperatures

For tests at extreme temperatures, measurements shall be made in accordance with the procedures specified in clause 5.5, at the upper and lower temperatures:

- temperature: -30 °C to +70 °C;

The manufacturer can also declare which extreme conditions the equipment is intended to be installed in. In this case the upper temperature can be above +70 °C and the lower temperature can be below -30 °C as declared by the manufacturer.

5.4.2 Extreme test source voltages

5.4.2.1 Mains voltage

The extreme test voltage for equipment to be connected to an ac mains source shall be the nominal mains voltage ± 10 %.

5.4.2.2 Regulated lead-acid battery power sources used on vehicles

When the equipment is intended for operation from the usual types of regulated lead-acid battery power sources used on vehicles the extreme test voltages shall be 1,3 and 0,9 times the nominal voltage of the battery (e.g. for a nominal voltage of 6 V, these are 7,8 V and 5,4 V respectively and for a nominal voltage of 12 V, these are 15,6 V and 10,8 V respectively).

5.4.2.3 Power sources using other types of batteries

The lower extreme test voltages for equipment with power sources using batteries shall be as follows:

- for the nickel metal-hydrate, leclanché or lithium type: 0,85 times the nominal battery voltage;
- for the mercury or nickel-cadmium type: 0,9 times the nominal battery voltage.

No upper extreme test voltages apply.

In the case where there is no upper extreme test voltage the nominal voltage is applicable, the corresponding four extreme test conditions are:

- V_{min}/T_{min} , V_{min}/T_{max} ;
- $(V_{nominal})/T_{min}$, $(V_{nominal})/T_{max}$.

5.4.2.4 Other power sources

For equipment using other power sources, or capable of being operated from a variety of power sources, the extreme test voltages shall be those declared by the equipment manufacturer.

5.5 Procedure for tests at extreme temperatures

Before measurements are made the equipment shall have reached thermal balance in the test chamber. The equipment shall be switched off during the temperature stabilizing period.

In the case of equipment containing temperature stabilization circuits designed to operate continuously, the temperature stabilization circuits may be switched on for 15 minutes after thermal balance has been obtained, and the equipment shall then meet the specified requirements. For such equipment the manufacturer shall provide for the power source circuit feeding the crystal oven to be independent of the power source for the rest of the equipment.

If the thermal balance is not checked by measurements, a temperature stabilizing period of at least one hour, or a longer period as may be decided by the testing laboratory, shall be allowed. The sequence of measurements shall be chosen, and the humidity content in the test chamber shall be controlled so that excessive condensation does not occur.

5.5.1 Procedure for equipment designed for continuous transmission

If the manufacturer states that the equipment is designed for continuous transmission, the test procedure shall be as follows.

Before tests at the upper extreme temperature, the equipment shall be placed in the test chamber, and left until thermal balance is attained. The equipment shall then be switched on in the transmit condition for a period of half an hour, after which the equipment shall meet the specified requirements.

Before tests at the lower extreme temperature, the equipment shall be left in the test chamber until thermal balance is attained, then switched to the standby or receive condition for a period of one minute, after which the equipment shall meet the specified requirements.

5.5.2 Procedure for equipment designed for intermittent transmission

If the manufacturer states that the equipment is designed for intermittent transmission, the test procedure shall be as follows.

Before tests at the upper extreme temperature, the equipment shall be placed in the test chamber, and left until thermal balance is attained. The equipment shall then be switched on for one minute in the transmit condition, followed by four minutes in the receive condition, after which the equipment shall meet the specified requirements.

For tests at the lower extreme temperature, the equipment shall be left in the test chamber until thermal balance is attained, then switched to the standby or receive condition for one minute, after which the equipment shall meet the specified requirements.

5.5.3 Testing of equipment that does not have an external 50 Ω RF connector (integral antenna equipment)

Where equipment has an internal 50 Ω connector it shall be permitted to perform the tests at this connector.

Equipment may also have a temporary internal 50 Ω connector installed for the purposes of testing.

No connection shall be made to any internal permanent or temporary antenna connector during the performance of radiated emissions measurements, unless such action forms an essential part of the normal intended operation of the equipment, as declared by the manufacturer.

6 Technical requirements specifications

6.1 Environmental profile

The technical requirements of the present document apply under the environmental profile for operation of the equipment, which shall be stated by the manufacturer. The equipment shall comply with all the technical requirements of the present document at all times when operating within the boundary limits of the stated operational environmental profile.

6.2 Carrier Frequencies

6.2.1 Definition

The equipment is required to operate on the applicable specific carrier centre frequencies that correspond to the nominal carrier frequencies f_c defined in table 2.

Table 2: Nominal carrier frequency allocations

Channel number	Carrier centre frequency f_c (MHz)	Maximum channel bandwidth (MHz)
1	5 860	10
2	5 865	20
3	5 870	10
4	5 880	10
5	5 890	10
6	5 900	10
7	5 910	10
8	5 915	20
9	5 920	10
10	5 890	30

The following channel bundling options can be used:

Channels 1 and 3 can optionally be used as channel 2 with a maximum channel bandwidth of up to 20 MHz.

Channels 7 and 9 can optionally be used as channel 8 with a maximum channel bandwidth of up to 20 MHz.

Channels 4, 5 and 6 can optionally be used as channel 10 with a maximum channel bandwidth of up to 30 MHz.

6.2.2 Limits

The actual carrier centre frequency for any given channel given in table 2 shall be maintained within the range $f_c \pm 10$ ppm.

6.2.3 Conformance

Conformance tests as defined in clause 7.3.2 shall be carried out.

6.3 RF Output Power, Transmit Power Control (TPC) and Power Spectral Density (PSD)

6.3.1 Definitions

6.3.1.1 RF output power

The RF output power is the total mean equivalent isotropically radiated power during a transmission burst.

6.3.1.2 Transmit Power Control

Transmit Power Control (TPC) is a mechanism to be used by the UUT to ensure an interference mitigation on the aggregate power from a large number of devices. The TPC mechanism shall provide the full range from the highest to the lowest power level of the device.

6.3.1.3 Power Spectral Density

The Power Spectral Density (PSD) is the mean equivalent isotropically radiated power spectral density during a transmission burst.

6.3.2 Limits

6.3.2.1 Total RF output power and power spectral density at the highest power level

The total RF output power and the power spectral density when configured to operate at the highest stated power level of the TPC range shall not exceed the levels given in table 3.

Table 3: Limits for total RF output power and Power Spectral Density at the highest power level

Frequency range (MHz)	RF output power limit (e.i.r.p.) (dBm)	Power spectral density limit (e.i.r.p.) (dBm/MHz)
5 855 to 5 925	33	23 (to be adjusted pro rata for channels having a channel bandwidth of more than 10 MHz)

6.3.2.2 Total RF output power and power spectral density at the lowest power level

The total RF output power and the power spectral density when configured to operate at the lowest stated power level of the TPC range shall not exceed the levels given in table 4.

Table 4: Limits for total RF output power and Power Spectral Density at the lowest power level

Frequency range (MHz)	RF output power limit (e.i.r.p.) (dBm)	Power Spectral Density limit (e.i.r.p.) (dBm/MHz)
5 855 to 5 925	3	-7

6.3.3 Conformance

Conformance tests as defined in clause 7.3.3 shall be carried out.

6.4 Transmitter unwanted emissions

6.4.1 Transmitter unwanted emissions outside the 5 GHz ITS frequency bands

6.4.1.1 Definition

These are radio frequency emissions outside the 5 GHz ITS bands from 5 855 MHz to 5 925 MHz.

6.4.1.2 Limits

The level of unwanted emission shall not exceed the limits given in tables 5 and 6.

Table 5: Transmitter unwanted emission limits below 1 GHz

Frequency range	Maximum power, (e.i.r.p.) (dBm)	Reference bandwidth
$30 \text{ MHz} \leq f < 1 \text{ GHz}$	-36	100 kHz

Table 6: Transmitter unwanted emission limits from 1 GHz to 18 GHz and outside the 5 GHz ITS frequency bands

Frequency range	Maximum power, (e.i.r.p.) (dBm)	Reference bandwidth
$1 \text{ GHz} \leq f < 5,795 \text{ GHz}$	-30	1 MHz
$5,795 \text{ GHz} \leq f < 5,815 \text{ GHz}$	-65	1 MHz
$5,815 \text{ GHz} \leq f < 5,850 \text{ GHz}$	-55	1 MHz
$5,850 \text{ GHz} \leq f < 5,855 \text{ GHz}$	-30	1 MHz
$5,925 \text{ GHz} \leq f < 5,965 \text{ GHz}$	-65	1 MHz
$5,965 \text{ GHz} \leq f \leq 18 \text{ GHz}$	-30	1 MHz

6.4.1.3 Conformance

Conformance tests as defined in clause 7.3.4 shall be carried out.

6.4.2 Transmitter unwanted emissions within the 5 GHz ITS frequency bands

6.4.2.1 Definition

These are unwanted radio frequency emissions (e.i.r.p.) from the transmitter within the 5 GHz ITS bands at the highest power level of the equipment.

6.4.2.2 Limits

The mean levels of the transmitted spectrum within the 5 GHz ITS bands shall not exceed the limits given in tables 7a, 7b and 7c respectively.

Table 7a: Transmitter unwanted emission limits inside the 5 GHz ITS bands (e.i.r.p.) - 10 MHz channel bandwidth

Power Spectral Density at the carrier centre frequency f_c (dBm/MHz)	$\pm 4,5$ MHz Offset (dBm/MHz)	$\pm 5,0$ MHz Offset (dBm/MHz)	$\pm 5,5$ MHz Offset (dBm/MHz)	± 10 MHz Offset (dBm/MHz)	± 15 MHz Offset (dBm/MHz)
23	23	-3	-9	-17	-27

Table 7b: Transmitter unwanted emission limits inside the 5 GHz ITS bands (e.i.r.p.) - 20 MHz channels

Power Spectral Density at the carrier centre frequency f_c (dBm/MHz)	$\pm 9,0$ MHz Offset (dBm/MHz)	$\pm 10,0$ MHz Offset (dBm/MHz)	$\pm 11,0$ MHz Offset (dBm/MHz)
23	23	-3	-9

Table 7c: Transmitter unwanted emission limits inside the 5 GHz ITS bands (e.i.r.p.) - 30 MHz channels

Power Spectral Density at the carrier centre frequency f_c (dBm/MHz)	$\pm 13,5$ MHz Offset (dBm/MHz)	$\pm 15,0$ MHz Offset (dBm/MHz)	$\pm 16,5$ MHz Offset (dBm/MHz)	± 30 MHz Offset (dBm/MHz)
23	23	-3	-9	-27

NOTE: For unwanted emissions outside the frequency range from 5 855 MHz to 5 925 MHz the limits in clause 6.4.1.2, tables 5 and 6 apply.

6.4.2.3 Conformance

Conformance tests as defined in clause 7.3.5 shall be carried out.

6.5 Receiver spurious emissions

6.5.1 Definition

Receiver spurious emissions are emissions at any frequency when the equipment is in receive mode.

6.5.2 Limits

The spurious emissions of the receiver shall not exceed the limits given in table 8.

Table 8: Spurious radiated emission limits

Frequency range	Maximum power	Measurement bandwidth
$30 \text{ MHz} \leq f < 1 \text{ GHz}$	-57 dBm (e.r.p.)	100 kHz
$1 \text{ GHz} \leq f \leq 18 \text{ GHz}$	-47 dBm (e.i.r.p.)	1 MHz

6.5.3 Conformance

Conformance tests as defined in clause 7.3.6 shall be carried out.

6.6 Listen Before Talk threshold

6.6.1 Definitions

The LBT threshold is defined as the received signal level above which the equipment can determine that the channel is not available for use. If the received signal is below the LBT threshold then the equipment can determine that the channel is available for use.

This requirement applies only to equipment operating in the frequency range from 5 855 MHz to 5 875 MHz.

6.6.2 Limits

The maximum LBT threshold for the receiver is given in table 9.

Table 9: LBT threshold values

ITS Power Spectral Density (dBm/MHz)	LBT threshold value (see notes 1 and 2)
23	-85 dBm
NOTE 1: This is the level at the input of the receiver assuming a 0 dBi receive antenna.	
NOTE 2: For ITS devices employing lower e.i.r.p. spectral density and a receive antenna gain G (dBi) the threshold follows the following relationships: LBT Detection Threshold (dBm) = -85 + 23 – ITS e.i.r.p. Spectral Density (dBm/MHz) + G (dBi). See table 10 for example calculations.	

Table 10: Example interference threshold values

Maximum e.i.r.p. (dBm)	Channel Width (MHz)	ITS Spectral Density (dBm/MHz)	LBT Threshold (dBm), for receive antenna gain G (dBi) = 5	LBT Threshold (dBm), for receive antenna gain G (dBi) = 8
33	10	23	-80	-77
33	20	20	-77	-74
30	10	20	-77	-74
30	20	17	-74	-71
27	10	17	-74	-71

6.6.3 Conformance

Conformance tests as defined in clause 7.3.7 shall be carried out.

6.7 Receiver blocking or desensitization

6.7.1 Definition

Blocking is a measure of the capability of the receiver to receive a wanted modulated signal without exceeding a given degradation due to the presence of an unwanted input signal at any frequencies other than those of the spurious responses or the adjacent channels or bands.

This requirement applies only to equipment operating in the frequency range from 5 855 MHz to 5 875 MHz.

6.7.2 Limits

The absolute blocking level into the receiver shall not be less than -35 dBm for a wanted signal level for generator A (see clause 7.3.8.2) of +16 dB above the LBT threshold.

6.7.3 Conformance

Conformance tests as defined in clause 7.3.8 shall be carried out.

7 Testing for compliance with technical requirements

7.1 Conditions for testing

7.1.1 Normal and extreme test conditions

Tests defined in the present document shall be carried out under normal test conditions and where stated, under the extreme test conditions as declared by the manufacturer.

7.1.2 Test modulation

The test modulation used should be representative of normal use of the equipment. Where the equipment is not capable of continuous RF transmission, the test modulation shall be such that:

- the generated RF signal is the same frame structure with random data for each transmission;
- transmissions occur regularly in time;
- sequences of transmissions can be repeated accurately.

The same test modulation shall be used for all measurements on the same equipment. For transmitters that have multi-modulation schemes incorporated, the manufacturer shall declare the modulation scheme to be used for the tests.

The test transmissions shall be fixed in length in a sequence and shall exceed the transmitter minimum activity ratio of 10 %. The minimum duration of the sequence shall be adequate for the test purposes.

Implemented transmitter timeout functionality shall be disabled for the sequence of the test suite.

7.1.3 Presentation of equipment

Each equipment submitted for testing, where applicable, shall fulfil the requirements of the present document on all of the nominal carrier frequencies as shown in table 2 over which it is intended to operate.

The provider shall provide one or more samples of the equipment, as appropriate for testing.

Additionally, technical documentation and operating manuals, sufficient to allow testing to be performed, shall be supplied.

The performance of the equipment submitted for testing shall be representative of the performance of the corresponding production model.

Equipment shall be offered by the provider complete with any ancillary equipment needed for testing. The provider shall declare the frequency range(s), the range of operation conditions and power requirements, as applicable, in order to establish the appropriate test conditions.

7.2 Interpretation of the measurement results

The interpretation of the results recorded in a test report for the measurements described in the present document shall be as follows:

- the measured value related to the corresponding limit shall be used to decide whether an equipment meets the requirements of the present document;
- the value of the measurement uncertainty for the measurement of each parameter shall be included in the test report;
- the recorded value of the measurement uncertainty shall be, for each measurement, equal to or lower than the figures in table 11.

For the test methods to determine RF power levels, according to the present document, the measurement uncertainty figures shall be calculated in accordance with TR 100 028-1 [1] and TR 100 028-2 [1] and shall correspond to an expansion factor (coverage factor) $k = 1,96$ or $k = 2$ (which provide confidence levels of respectively 95 % and 95,45 % in the case where the distributions characterizing the actual measurement uncertainties are normal (Gaussian)).

Table 11 is based on such expansion factors.

Table 11: Maximum measurement uncertainty

Parameter	Uncertainty
RF frequency	$\pm 1 \times 10^{-5}$
RF power conducted	$\pm 1,5$ dB
RF power radiated	± 6 dB
Humidity	± 5 %
Temperature	± 1 °C

7.3 Essential radio test suites

7.3.1 Product information

The following information is necessary in order to carry out the test suites:

- the type of modulation used;
- the operating nominal carrier frequency range(s) of the equipment;
- the type of the equipment: integral antenna or dedicated antenna;
- the extreme operating conditions that apply to the equipment;
- the intended combination(s) of the radio equipment power settings and one or more antenna assemblies and their corresponding e.i.r.p. spectral density levels;
- the nominal operating voltages of the radio equipment or the nominal voltages of the host equipment (e.g. a car or RSU);
- the test modulation used in detail.

7.3.2 Carrier Frequencies

7.3.2.1 Test conditions

These measurements shall be performed under both normal and extreme test conditions.

For a UUT with antenna connector(s) and using dedicated external antenna(s), or for a UUT with integral antenna(s) but with a temporary antenna connector provided, conducted measurements shall be used.

For a UUT with integral antenna(s) and without a temporary antenna connector, radiated measurements shall be used.

7.3.2.2 Test methods

7.3.2.2.1 Conducted measurement

This method is used with the UUT in operation in an modulated mode.

The UUT shall be connected to the spectrum analyser.

The settings of the spectrum analyser shall be adjusted to optimize the instruments frequency accuracy.

Max Hold shall be selected and the centre frequency adjusted to that of the UUT.

The peak value of the power envelope shall be measured and recorded. The span shall be reduced and the marker moved in a positive frequency increment until the upper, (relative to the centre frequency), -10 dBc point is reached. This value shall be noted as f1.

The marker shall then be moved in a negative frequency increment until the lower, (relative to the centre frequency), -10 dBc point is reached. This value shall be noted as f2.

The centre frequency is calculated as $(f1 + f2) / 2$.

7.3.2.2.2 Radiated measurement

The test set up as described in annex B shall be used with a spectrum analyser of sufficient accuracy attached to the test antenna.

The test procedure is as described under clause 7.3.2.2.1.

7.3.3 RF Output Power, Transmit Power Control (TPC) and Power Spectral Density (PSD)

7.3.3.1 Test conditions

These measurements shall be performed under both normal and extreme test conditions.

For a UUT with antenna connector(s) and using dedicated external antenna(s), or for a UUT with integral antenna(s) but with a temporary antenna connector provided, conducted measurements shall be used.

For a UUT with integral antenna(s) and without a temporary antenna connector, radiated measurements shall be used.

7.3.3.2 Test method

7.3.3.2.1 Conducted measurement

7.3.3.2.1.1 RF output power at the highest power level

The UUT shall be configured to operate at the highest stated transmitter output power level of the TPC range.

Step 1:

- a) using suitable attenuators, the output power of the transmitter shall be coupled to a matched diode detector or equivalent thereof. The output of the diode detector shall be connected to the vertical channel of an oscilloscope;
- b) the combination of the diode detector and the oscilloscope shall be capable of faithfully reproducing the duty cycle of the transmitter output signal;
- c) the observed duty cycle of the transmitter (Tx on/(Tx on + Tx off)) shall be noted as x ($0 < x \leq 1$), and recorded in the test report. For the purpose of testing, the equipment shall be operated with a duty cycle that is equal to or greater than 0,1.

Step 2:

- a) the RF output power of the transmitter when operating at the highest power level shall be determined using a wideband calibrated RF power meter with a matched thermocouple detector or an equivalent thereof and with an integration period that exceeds the repetition period of the transmitter by a factor 5 or more. The observed value shall be noted as "A" (in dBm);
- b) the e.i.r.p. shall be calculated from the above measured power output A (in dBm), the observed duty cycle x , and the stated antenna gain "G" in dBi, according to the formula in c). If more than one antenna assembly is intended for this power setting or TPC range, the gain of the antenna assembly with the highest gain shall be used;
- c) $P_H = A + G + 10 \log(1/x)$ (dBm);
- d) P_H shall be recorded in the test report.

7.3.3.2.1.2 RF output power at the lowest power level

The UUT shall be configured to operate at the lowest stated transmitter output power level of the TPC range.

Step 1:

- a) using suitable attenuators, the output power of the transmitter shall be coupled to a matched diode detector or equivalent thereof. The output of the diode detector shall be connected to the vertical channel of an oscilloscope;
- b) the combination of the diode detector and the oscilloscope shall be capable of faithfully reproducing the duty cycle of the transmitter output signal;
- c) the observed duty cycle of the transmitter (Tx on/(Tx on + Tx off)) shall be noted as x ($0 < x \leq 1$), and recorded in the test report. For the purpose of testing, the equipment shall be operated with a duty cycle that is equal to or greater than 0,1.

Step 2:

- a) the RF output power of the transmitter when operating at the lowest power level of the TPC range shall be determined using a wideband calibrated RF power meter with a matched thermocouple detector or an equivalent thereof and with an integration period that exceeds the repetition period of the transmitter by a factor 5 or more. The observed value shall be noted as "A" (in dBm);
- b) the e.i.r.p. shall be calculated from the above measured power output A (in dBm), the observed duty cycle x , and the stated antenna gain "G" in dBi, according to the formula in c). If more than one antenna assembly is intended for this TPC range, the gain of the antenna assembly with the highest gain shall be used;

- c) $P_L = A + G + 10 \log (1/x)$ (dBm);
- d) P_L shall be recorded in the test report.

7.3.3.2.1.3 Power Spectral Density

The UUT shall be operated as described in clause 7.3.3.2.1.1. Furthermore, for the purpose of this test, the minimum transmitter on-time shall be 10 μ s.

The transmitter shall be connected to the measuring equipment via a suitable attenuator and the power spectral density as defined shall be measured and recorded.

The power spectral density shall be determined using a spectrum analyser of adequate bandwidth in combination with an RF power meter.

Connect an RF power meter to the narrow IF output of the spectrum analyser and correct its reading using a known reference source, e.g. a signal generator.

NOTE: The IF output of the spectrum analyser may be 20 dB or more below the input level of the spectrum analyser. Unless the power meter has adequate sensitivity, a wideband amplifier may be required.

The test procedure shall be as follows:

Step 1:

- a) the measurement set-up shall be calibrated with a CW signal from a calibrated source; the reference signal shall be set to a level equal to the value for the applicable limit for e.i.r.p.spectral density (reduced by the highest applicable antenna gain) and at a frequency equal to the centre frequency of the channel being tested;
- b) the settings of the spectrum analyser shall be:
 - centre Frequency: equal to the signal source;
 - resolution BW: 1 MHz;
 - video BW: 1 MHz;
 - detector mode: positive peak;
 - averaging: off;
 - span: zero Hz;
 - reference level: equal to the level of the reference signal.

Step 2:

- a) the calibrating signal power shall be reduced by 10 dB and it shall be verified that the power meter reading also reduces by 10 dB.

Step 3:

- a) connect the UUT. Using the following settings of the spectrum analyser in combination with "max hold" function, find the frequency of highest power output in the power envelope:
 - centre Frequency: equal to operating frequency;
 - resolution BW: no change to the setting in step 1;
 - video BW: no change to the setting in step 1;
 - detector mode: no change to the setting in step 1;
 - averaging: no change to the setting in step 1;
 - span: 1,5 times the spectrum width;

- reference level: no change to the setting in step 1;
- b) the frequency found shall be recorded;
- c) the centre frequency of the spectrum analyser shall be set to the recorded frequency, the span shall be further reduced to 1 MHz and the frequency of the highest power output shall be found. If this frequency is different from the previous recorded frequency, the new frequency shall be recorded.

Step 4:

- a) set the centre frequency of the spectrum analyser to the found frequency and switch to zero span. The power meter indicates the measured power density (D). The mean power density e.i.r.p. is calculated from the above measured power density (D), the observed duty cycle x (see clause 7.3.3.2.1.1 step 1), and the applicable antenna assembly gain "G" in dBi, according to the formula below. If more than one antenna assembly is intended for this power setting or TPC range, the gain of the antenna assembly with the highest gain shall be used:
 - $PD = D + G + 10 \log (1/x)$;
 - PD shall be recorded in the test report.

The above procedure shall be repeated for each of the frequencies declared by the provider.

Where the spectrum analyser bandwidth is non-Gaussian, a suitable correction factor shall be determined and applied.

Where a spectrum analyser is equipped with a facility to measure power density, this facility may be used instead of the above procedure to measure the power density across the occupied channel bandwidth.

7.3.3.2.2 Radiated measurement

In the case of radiated measurements, using a test site as described in annex B and applicable measurement procedures as described in annex C, the power spectral density as defined shall be measured and recorded.

The test procedure is as described under clause 7.3.3.2.1.

7.3.4 Transmitter unwanted emissions outside the 5 GHz ITS bands

7.3.4.1 Test conditions

The measurements shall be performed under normal test conditions. The UUT shall be configured to operate at the highest stated power level.

For UUT without an integral antenna and for a UUT with an integral antenna but with a temporary antenna connector, one of the following options shall be used:

- a) the level of unwanted emissions shall be measured as their power in a specified load (conducted unwanted emissions) and their radiated power when radiated by the cabinet or structure of the equipment with the antenna connector terminated by a specified load (cabinet radiation); or
- b) the level of unwanted emissions shall be measured as their radiated power when radiated by cabinet and antenna.

In the case where the UUT has an integral antenna, but no temporary antenna connector, only radiated measurements shall be used.

The measurements shall be conducted using a quasi-peak detector for frequencies below 1 GHz and a positive peak detector on frequencies of 1 GHz and above.

7.3.4.2 Test method

7.3.4.2.1 Conducted measurement

The UUT shall be connected to a spectrum analyser capable of RF power measurements. The test procedure shall be as follows:

- a) the settings of the spectrum analyser shall be as follows:
 - sensitivity: at least 6 dB below the limits given in tables 5 and 6;
 - video bandwidth: 1 MHz;
 - video averaging on, or peak hold.

The video signal of the spectrum analyser shall be "gated" such that the spectrum measured shall be measured between 4,0 µs before the start of the burst to 4,0 µs after the end of the burst.

NOTE: The "start of the burst" is the centre of the first sample of the preamble heading the burst. The "end of the burst" is the centre of the last sample in the burst.

This gating may be analogue or numerical, dependent upon the design of the spectrum analyser:

- b) initially the power level shall be measured in the ranges:
 - 30 MHz to 1 000 MHz;with a resolution bandwidth of 1 MHz and in a frequency scan mode.
- c) if any measurement is greater than the limit of -36 dBm then measurements shall be taken with a resolution bandwidth of 100 kHz, zero frequency scan, at the 11 frequencies spaced 100 kHz apart in a band $\pm 0,5$ MHz centred on the failing frequency;

EXAMPLE: A UUT fails at 495 MHz. Measurements are made in a 100 kHz bandwidth on 494,5 MHz; 494,6 MHz; 494,7 MHz; etc. up to 495,5 MHz.

- d) the power level shall be measured in the ranges:
 - 1 GHz to 5,795 GHz;
 - 5,965 GHz to 18 GHz;with a resolution bandwidth of 1 MHz and in a frequency scan mode.
- e) the power level shall be measured in the range:
 - 5,795 GHz to 5,855 GHz;
 - 5,925 GHz to 5,965 GHz;
 - and with zero frequency span.

7.3.4.2.2 Radiated measurement

The test set up as described in annex B shall be used with a spectrum analyser of sufficient accuracy attached to the test antenna.

The test procedure is as described under clause 7.3.4.2.1.

7.3.5 Transmitter unwanted emissions within the 5 GHz ITS bands

7.3.5.1 Test conditions

The measurements be performed under normal test conditions. The UUT shall be configured to operate at the highest stated power level.

For UUT without an integral antenna and for a UUT with an integral antenna but with a temporary antenna connector, one of the following options shall be used:

- a) the level of unwanted emissions shall be measured as their power in a specified load (conducted unwanted emissions) and their radiated power when radiated by the cabinet or structure of the equipment with the antenna connector terminated by a specified load (cabinet radiation); or
- b) the level of unwanted emissions shall be measured as their radiated power when radiated by cabinet and antenna.

In the case where the UUT has an integral antenna, but no temporary antenna connector, only radiated measurements shall be used.

7.3.5.2 Test method

7.3.5.2.1 Conducted measurement

The settings of the spectrum analyser shall be as follows:

- resolution bandwidth: 1 MHz;
- video bandwidth: 30 kHz;
- video averaging on.

The video signal of the spectrum analyser shall be "gated" such that the spectrum measured shall be measured between 4,0 μ s before the start of the burst to 4,0 μ s after the end of the burst.

NOTE: The "start of the burst" is the centre of the first sample of the preamble heading the burst. The "end of the burst" is the centre of the last sample in the burst.

This gating may be analogue or numerical, dependent upon the design of the spectrum analyser.

Determination of the reference average power level:

The spectrum analyser shall be tuned to measurement frequencies at every 1 MHz interval within $f_c - 4$ MHz to $f_c + 4$ MHz, with zero frequency scan. The maximum average power within $f_c - 4$ MHz to $f_c + 4$ MHz (except f_c) is the reference level for relative power measurements on the channel centred at f_c and shall be recorded to compute relative power levels as described below.

Determination of the relative average power levels:

The power level shall be measured in the range from 5 855 MHz to 5 925 MHz excluding the interval $f_c - 4$ MHz to $f_c + 4$ MHz with a resolution bandwidth of 1 MHz and in a frequency scan mode. The average value of power relative to the reference average power level for the channel shall be recorded.

7.3.5.2.2 Radiated measurement

The test set up as described in annex B shall be used with a spectrum analyser of sufficient accuracy attached to the test antenna.

The test procedure is as described under clause 7.3.5.2.1.

7.3.6 Receiver spurious emissions

7.3.6.1 Test conditions

The measurement shall be performed under normal test conditions.

For UUT without an integral antenna and for a UUT with an integral antenna but with a temporary antenna connector, one of the following options shall be used:

- a) the level of spurious emissions shall be measured as their power in a specified load (conducted spurious emissions) and their radiated power when radiated by the cabinet or structure of the equipment with the antenna connector terminated by a specified load (cabinet radiation); or
- b) the level of spurious emissions shall be measured as their radiated power when radiated by cabinet and antenna.

In the case where the UUT has an integral antenna, but no temporary antenna connector, only radiated measurements shall be used.

The measurements shall be conducted using a quasi-peak detector for frequencies below 1 GHz and a positive peak detector on frequencies of 1 GHz and above.

7.3.6.2 Test method

7.3.6.2.1 Conducted measurement

Using a directional coupler, circulator or gating to remove the test transmissions (and/or other means to isolate the emissions measurements instrument from the test data signals transmitted) the radio emissions from the UUT shall be measured while the UUT receives test data.

The settings of the spectrum analyser shall be as follows:

- frequency scan allowed;
- resolution bandwidth: 1 MHz or 100 kHz;
- video bandwidth: 1 MHz;
- video averaging on, or peak hold.

Tuning the spectrum analyser centre frequency over the measurement frequency bands specified in table 8, the power level of UUT receiver emissions shall be measured during test transmissions. If gating is used to remove the unwanted energy from the test data transmissions, the tuning of the spectrum analyser shall not change during the gated-out time interval.

7.3.6.2.2 Radiated measurement

The test set up as described in annex B shall be used with a spectrum analyser of sufficient accuracy attached to the test antenna.

The test procedure is as described under clause 7.3.5.2.1.

7.3.7 Receiver LBT threshold

7.3.7.1 Test conditions

This measurement shall be conducted under normal conditions.

7.3.7.2 Test method

A signal generator and a power meter are each combined via appropriate attenuators into the equipment antenna connector. The test set-up in figure 1 shall be used.

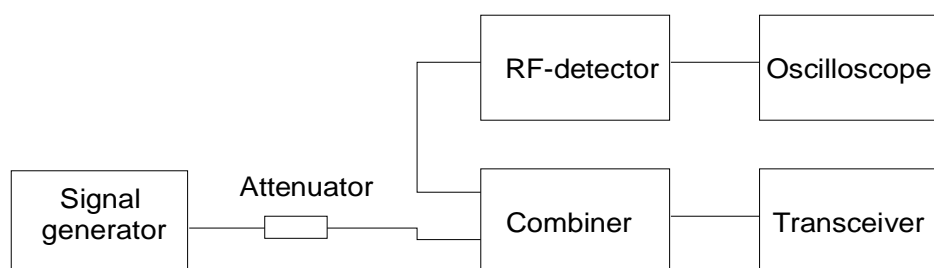

Figure 1: Measurement arrangement

For equipment with integral antenna the connection to the equipment is made to a temporary 50 Ω antenna connector.

In addition:

- a) the LBT function of the transceiver shall be active;
- b) the attenuator shall provide sufficient attenuation to protect the signal generator from burn-out by the transmitter of the transceiver;
- c) the signal generator with normal test modulation shall be adjusted to the receiving frequency. The level shall be increased to approximately 20 dB above the receiver sensitivity;
- d) the equipment shall be switched to an intended transmit mode;

NOTE: The equipment is not transmitting because the transceiver recognizes a busy channel from the signal generator.

- e) the level of the signal generator shall be reduced in steps of 1 dB until the equipment starts to transmit. This specific signal generator level present at the receiver input of the transceiver is the LBT threshold;

The level of the received LBT threshold shall be recorded in the test report.

- f) the steps c) and e) shall be repeated over all carrier frequencies.

The limit for total listen time for the receiver for the LBT check shall not exceed 8 μ s in a 10 MHz channel and 4 μ s in a 20 MHz channel. This shall be declared by the provider and recorded in the test report.

7.3.8 Receiver blocking or desensitization

7.3.8.1 Test conditions

This measurement shall be conducted under normal conditions.

7.3.8.2 Test method

The test set-up in figure 2 shall be used.

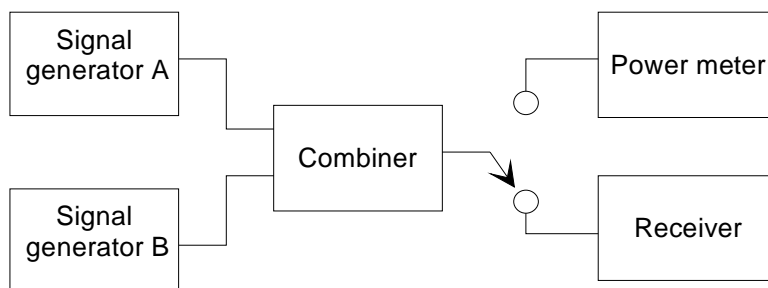

Figure 2: Measurement arrangement

Two signal generators A and B shall be connected to the receiver via a combining network to the receiver antenna connector.

For equipment with integral antenna the connection to the equipment is made to a temporary 50 Ω antenna connector.

Signal generator A shall be at the carrier frequency of the receiver, with normal modulation of the wanted signal. Signal generator B shall be unmodulated and shall be adjusted to a test frequencies of approximately + 10 MHz (+ 15 MHz for channel 2) relative to the carrier frequency of the receiver. Initially signal generator B shall be switched off and using signal generator A at a level adjusted +16 dB above the LBT threshold.

Signal generator B is then switched on and adjusted until the wanted criteria, i.e. after demodulation, a message acceptance ratio of 90 % is just exceeded.

With signal generator B settings unchanged the power into the receiver is measured by replacing the receiver with a power meter. This level shall be recorded.

The tests shall be repeated with the frequency of signal generator B at approximately -10 MHz (- 15 MHz for channel 2) from the carrier frequency of the receiver.

Annex A (normative): HS Requirements and conformance Test specifications Table (HS-RTT)

The HS Requirements and conformance Test specifications Table (HS-RTT) in table A.1 serves a number of purposes, as follows:

- it provides a statement of all the requirements in words and by cross reference to (a) specific clause(s) in the present document or to (a) specific clause(s) in (a) specific referenced document(s);
- it provides a statement of all the test procedures corresponding to those requirements by cross reference to (a) specific clause(s) in the present document or to (a) specific clause(s) in (a) specific referenced document(s);
- it qualifies each requirement to be either:
 - Unconditional: meaning that the requirement applies in all circumstances; or
 - Conditional: meaning that the requirement is dependent on the manufacturer having chosen to support optional functionality defined within the schedule;
- in the case of Conditional requirements, it associates the requirement with the particular optional service or functionality;
- it qualifies each test procedure to be either:
 - Essential: meaning that it is included with the Essential Radio Test Suite and therefore the requirement shall be demonstrated to be met in accordance with the referenced procedures;
 - Other: meaning that the test procedure is illustrative but other means of demonstrating compliance with the requirement are permitted.

Table A.1: HS Requirements and conformance Test specifications Table (HS-RTT)

Harmonized Standard EN 302 571						
The following requirements and test specifications are relevant to the presumption of conformity under the Article 3.2 of the R&TTE Directive						
Requirement			Requirement Conditionality		Test Specification	
No	Description	Reference: Clause No	U/C	Condition	E/O	Reference: Clause No
1	Carrier Frequencies	6.2	U		E	7.3.2
2	RF output power, Transmit Power Control (TPC) and Power Spectral Density (PSD)	6.3	U		E	7.3.3
3	Transmitter unwanted emissions outside the 5 GHz ITS frequency bands	6.4.1	U		E	7.3.4
4	Transmitter unwanted emissions within the 5 GHz ITS frequency bands	6.4.2	U		E	7.3.5
5	Receiver spurious emissions	6.5	U		E	7.3.6
6	Listen Before Talk threshold	6.6	C	Applies only for equipment operating in the frequency range from 5 855 MHz to 5 875 MHz	E	7.3.7
7	Receiver blocking or desensitization	6.7	C	Applies only for equipment operating in the frequency range from 5 855 MHz to 5 875 MHz	E	7.3.8

Key to columns:**Requirement:**

No A unique identifier for one row of the table which may be used to identify a requirement or its test specification.

Description A textual reference to the requirement.

Clause Number Identification of clause(s) defining the requirement in the present document unless another document is referenced explicitly.

Requirement Conditionality:

U/C Indicates whether the requirement is to be *unconditionally* applicable (U) or is *conditional* upon the manufacturers claimed functionality of the equipment (C).

Condition Explains the conditions when the requirement shall or shall not be applicable for a technical requirement which is classified "conditional".

Test Specification:

E/O Indicates whether the test specification forms part of the Essential Radio Test Suite (E) or whether it is one of the Other Test Suite (O).

NOTE: All tests whether "E" or "O" are relevant to the requirements. Rows designated "E" collectively make up the Essential Radio Test Suite; those designated "O" make up the Other Test Suite; for those designated "X" there is no test specified corresponding to the requirement. The completion of all tests classified "E" as specified with satisfactory outcomes is a necessary condition for a presumption of conformity. Compliance with requirements associated with tests classified "O" is a necessary condition for presumption of conformity, although conformance with the requirement may be claimed by an equivalent test or by manufacturer's assertion supported by appropriate entries in the technical construction file.

Clause Number Identification of clause(s) defining the test specification in the present document unless another document is referenced explicitly. Where no test is specified (that is, where the previous field is "X") this field remains blank.

Annex B (normative): Test sites and arrangements for radiated measurements

B.1 Test sites

B.1.1 Open air test sites

The term "open air" should be understood from an electromagnetic point of view. Such a test site may be really in open air or alternatively with walls and ceiling transparent to the radio waves at the frequencies considered.

An open air test site may be used to perform the measurements using the radiated measurement methods described in clause 5. Absolute or relative measurements may be performed on transmitters or on receivers; absolute measurements of field strength require a calibration of the test site. Above 1 GHz, measurements should be done in anechoic conditions. This may be met by semi anechoic sites provided reflections are avoided.

For measurements at frequencies below 1 GHz, a measurement distance appropriate to the frequency shall be used. For frequencies above 1 GHz, any suitable measuring distance may be used. The equipment size (excluding the antenna) shall be less than 20 % of the measuring distance. The height of the equipment or of the substitution antenna shall be 1,5 m; the height of the test antenna (transmit or receive) shall vary between 1 m and 4 m.

Sufficient precautions shall be taken to ensure that reflections from extraneous objects adjacent to the site do not degrade the measurement results, in particular:

- no extraneous conducting objects having any dimension in excess of a quarter wavelength of the highest frequency tested shall be in the immediate vicinity of the site according to CISPR 16 [2];
- all cables shall be as short as possible; as much of the cables as possible shall be on the ground plane or preferably below; and the low impedance cables shall be screened.

The general measurement arrangement is shown in figure B.1.

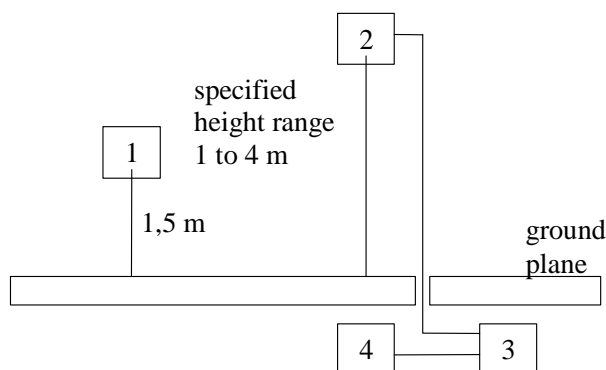

- NOTE: 1: Equipment under test.
2: Test antenna.
3: High pass filter (as required).
4: Spectrum analyser or measuring receiver.

Figure B.1: Measuring arrangement

B.1.2 Anechoic chamber

B.1.2.1 General

An anechoic chamber is a well shielded chamber covered inside with radio frequency absorbing material and simulating a free space environment. It is an alternative site on which to perform the measurements using the radiated measurement methods described in clause C.2. Absolute or relative measurements may be performed on transmitters or on receivers. Absolute measurements of field strength require a calibration of the anechoic chamber. The test antenna, equipment under test and substitution antenna are used in a way similar to that at the open air test site, but are all located at the same fixed height above the floor.

B.1.2.2 Description

An anechoic chamber should meet the requirements for shielding loss and wall return loss as shown in figure B.2. Figure B.3 shows an example of the construction of an anechoic chamber having a base area of 5 m by 10 m and a height of 5 m. The ceiling and walls are coated with pyramidically formed absorbers approximately 1 m high. The base is covered with special absorbers which form the floor. The available internal dimensions of the chamber are 3 m x 8 m x 3 m, so that a maximum measuring distance of 5 m in the middle axis of this chamber is available. The floor absorbers reject floor reflections so that the antenna height need not be changed. Anechoic chambers of other dimensions may be used.

B.1.2.3 Influence of parasitic reflections

For free-space propagation in the far field, the relationship of the field strength E and the distance R is given by $E = E_0 \times (R_0/R)$, where E_0 is the reference field strength and R_0 is the reference distance. This relationship allows relative measurements to be made as all constants are eliminated within the ratio and neither cable attenuation nor antenna mismatch or antenna dimensions are of importance.

If the logarithm of the foregoing equation is used, the deviation from the ideal curve may be easily seen because the ideal correlation of field strength and distance appears as a straight line. The deviations occurring in practice are then clearly visible. This indirect method shows quickly and easily any disturbances due to reflections and is far less difficult than the direct measurement of reflection attenuation.

With an anechoic chamber of the dimensions given above at low frequencies below 100 MHz there are no far field conditions, but the wall reflections are stronger, so that careful calibration is necessary. In the medium frequency range from 100 MHz to 1 GHz the dependence of the field strength to the distance meets the expectations very well. Above 1 GHz, because more reflections will occur, the dependence of the field strength to the distance will not correlate so closely.

B.1.2.4 Calibration and mode of use

The calibration and mode of use is the same as for an open air test site, the only difference being that the test antenna does not need to be raised and lowered whilst searching for a maximum, which simplifies the method of measurement.

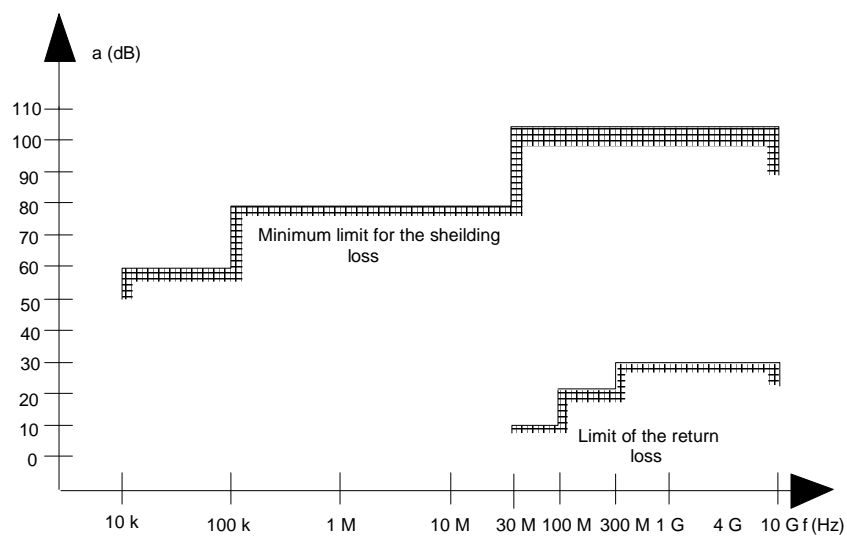

Figure B.2: Specification for shielding and reflections

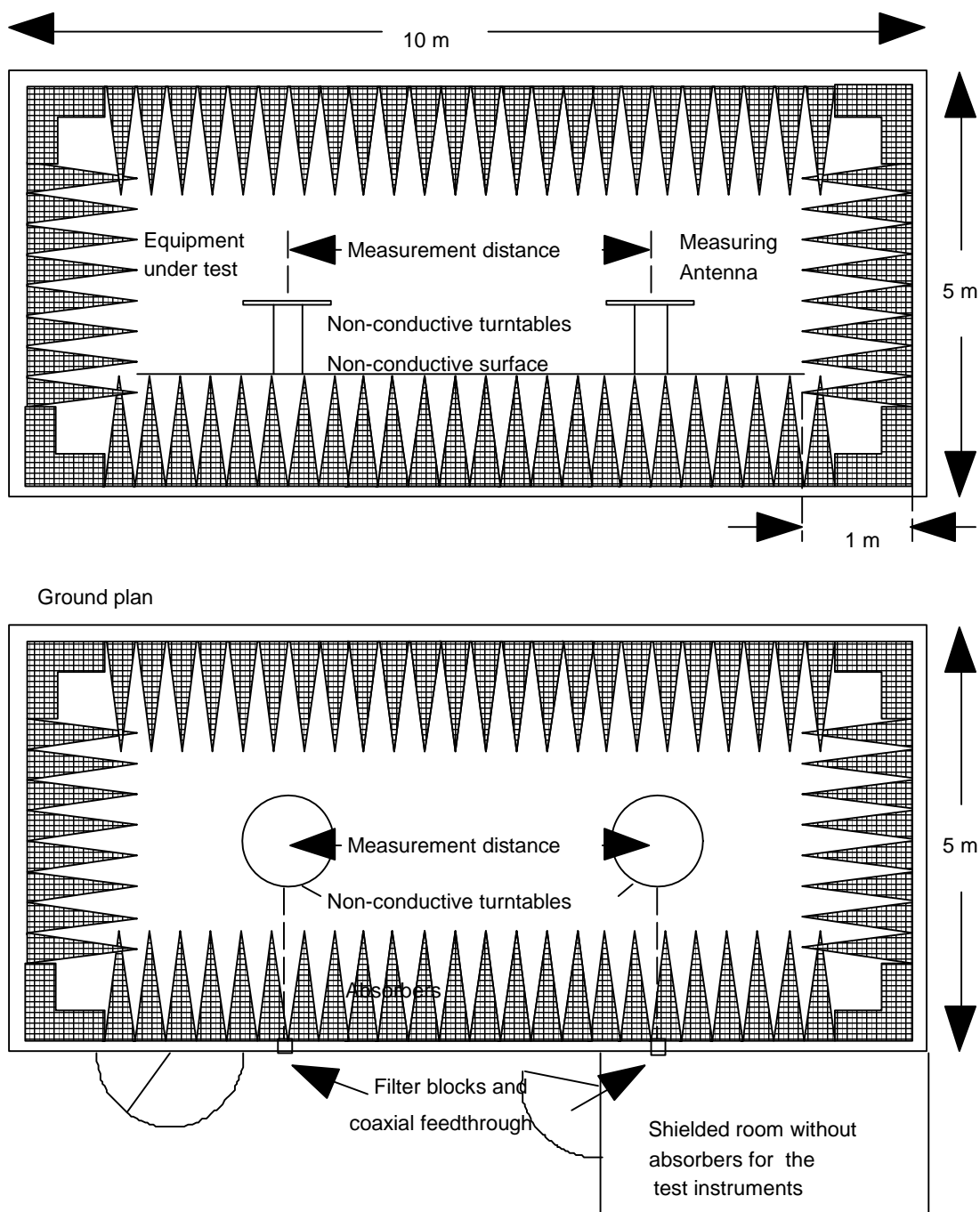

Figure B.3: Anechoic shielded chamber for simulated free space measurements

B.2 Test antenna

When the test site is used for radiation measurements the test antenna shall be used to detect the field from both the test sample and the substitution antenna. When the test site is used for the measurement of receiver characteristics the antenna shall be used as a transmitting antenna. This antenna shall be mounted on a support capable of allowing the antenna to be used in either horizontal or vertical polarization and for the height of its centre above the ground to be varied over the specified range. Preferably test antennas with pronounced directivity should be used. The size of the test antenna along the measurement axis shall not exceed 20 % of the measuring distance.

B.3 Substitution antenna

The substitution antenna shall be used to replace the UUT in substitution measurements. For measurements below 1 GHz the substitution antenna shall be a half wavelength dipole resonant at the frequency under consideration, or a shortened dipole, calibrated to the half wavelength dipole. For measurements between 1 GHz and 4 GHz either a half wavelength dipole or a horn radiator may be used. For measurements above 4 GHz a horn radiator shall be used. The centre of this antenna shall coincide with the reference point of the test sample it has replaced. This reference point shall be the volume centre of the sample when its antenna is mounted inside the cabinet, or the point where an outside antenna is connected to the cabinet.

The distance between the lower extremity of the dipole and the ground shall be at least 30 cm.

NOTE: The gain of a horn antenna is generally expressed relative to an isotropic radiator.

Annex C (normative): General description of measurement

This annex gives the general methods of measurements for RF signals using the test sites and arrangements described in annex B.

C.1 Conducted measurements

Conducted measurements may be applied to equipment provided with an antenna connector e.g. by means of a spectrum analyser.

C.2 Radiated measurements

Radiated measurements shall be performed with the aid of a test antenna and measurement instruments as described in annex B. The test antenna and measurement instrument shall be calibrated according to the procedure defined in this annex. The equipment to be measured and the test antenna shall be oriented to obtain the maximum emitted power level. This position shall be recorded in the measurement report. The frequency range shall be measured in this position.

Radiated measurements should be performed in an anechoic chamber. For other test sites corrections may be needed (see annex B). The following test procedure applies:

- a) a test site which fulfils the requirements of the specified frequency range of this measurement shall be used. The test antenna shall be oriented initially for vertical polarization unless otherwise stated and the transmitter under test shall be placed on the support in its standard position (clause B.1.1) and switched on;
- b) for average power measurements a non-selective voltmeter or wideband spectrum analyser shall be used. For other measurements a spectrum analyser or selective voltmeter shall be used and tuned to the measurement frequency.

In either case a) or b), the test antenna shall be raised or lowered, if necessary, through the specified height range until the maximum signal level is detected on the spectrum analyser or selective voltmeter.

The test antenna need not be raised or lowered if the measurement is carried out on a test site according to clause B.1.2.

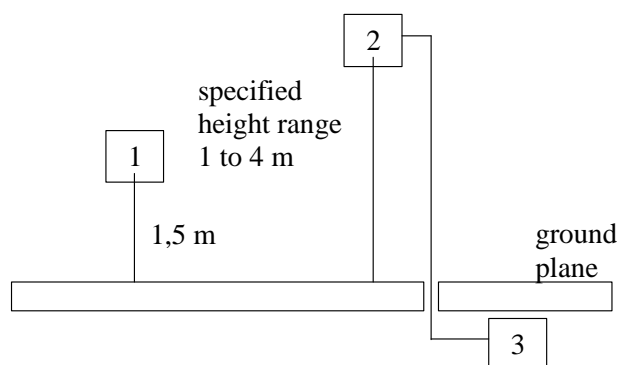

NOTE: 1: Equipment under test.
2: Test antenna.
3: Spectrum analyser or measuring receiver.

Figure C.1: Measurement arrangement 1

- the transmitter shall be rotated through 360° about a vertical axis until a higher maximum signal is received;
- the test antenna shall be raised or lowered again, if necessary, through the specified height range until a maximum is obtained. This level shall be recorded.

NOTE: This maximum may be a lower value than the value obtainable at heights outside the specified limits.

The test antenna need not be raised or lowered if the measurement is carried out on a test site according to clause B.1.2. This measurement shall be repeated for horizontal polarization. The result of the measurement is the higher power obtained from the two measurements with the indication of the corresponding polarization.

C.3 Substitution measurement

The actual signal generated by the measured equipment may be determined by means of a substitution measurement in which a known signal source replaces the device to be measured, see figure C.2. This method of measurement should be used in an anechoic chamber. For other test sites corrections may be needed, see annex B.

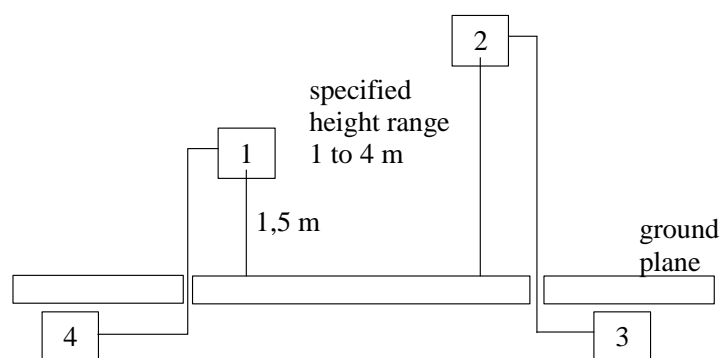

- NOTE: 1: Substitution antenna.
 2: Test antenna.
 3: Spectrum analyser or selective voltmeter.
 4: Signal generator.

Figure C.2: Measurement arrangement 2

Using measurement arrangement 2, figure C.2, the substitution antenna shall replace the transmitter antenna in the same position and in vertical polarization. The frequency of the signal generator shall be adjusted to the measurement frequency. The test antenna shall be raised or lowered, if necessary, to ensure that the maximum signal is still received. The input signal to the substitution antenna shall be adjusted in level until an equal or a known related level to that detected from the transmitter is obtained in the test receiver.

The test antenna need not be raised or lowered if the measurement is carried out on a test site according to clause B.1.2.

The radiated power is equal to the power supplied by the signal generator, increased by the known relationship if necessary and after corrections due to the gain of the substitution antenna and the cable loss between the signal generator and the substitution antenna.

This measurement shall be repeated with horizontal polarization. The result of the measurement is the higher power obtained from the two measurements with the indication of the corresponding polarization.

Annex D (informative): The EN title in the official languages

Language	EN title
Bulgarian	
Czech	
Danish	
Dutch	
English	Intelligent Transport Systems (ITS); Radiocommunications equipment operating in the 5 855 MHz to 5 925 MHz frequency band; Harmonized EN covering essential requirements of article 3.2 of the R&TTE Directive
Estonian	
Finnish	
French	
German	
Greek	
Hungarian	
Icelandic	
Italian	
Latvian	
Lithuanian	
Maltese	
Norwegian	
Polish	
Portuguese	
Romanian	
Slovak	
Slovenian	
Spanish	
Swedish	

Annex E (informative): Bibliography

ECC Decision of 14 March 2008 on the harmonized use of the 5875-5925 MHz frequency band for Intelligent transport systems (ITS).

ECC Recommendation (08)01: "Use of band 5855-5875 MHz for Intelligent Transport Systems (ITS)".

ECC Report 101: "Compatibility studies in the band 5855– 5925 MHz between Intelligent Transport Systems (ITS) and other systems".

ETSI TR 102 273 (2001-12) (all parts): "Electromagnetic compatibility and Radio spectrum Matters (ERM); Improvement of radiated methods of measurement (using test sites) and evaluation of the corresponding measurement uncertainties".

ANSI C63.5 (2004): "American National Standard for Electromagnetic Compatibility-Radiated Emission Measurements in Electromagnetic Interference (EMI) Control-Calibration of Antennas (9 kHz to 40 GHz)".

ETSI TR 102 492-1: "Electromagnetic compatibility and Radio spectrum Matters (ERM); Intelligent Transport Systems (ITS); Part 1: Technical characteristics for pan-European harmonized communications equipment operating in the 5 GHz frequency range and intended for critical road-safety applications; System Reference Document".

ETSI TR 102 492-2: "Electromagnetic compatibility and Radio spectrum Matters (ERM); Intelligent Transport Systems (ITS); Part 2: Technical characteristics for pan European harmonized communications equipment operating in the 5 GHz frequency range intended for road safety and traffic management, and for non-safety related ITS applications; System Reference Document".

Draft Commission Decision on the harmonized use of radio spectrum in the 5875-5905 MHz frequency band for safety related application of Intelligent Transport Systems (ITS).

History

Document history			
V0.0.2	December 2007	Public Enquiry	PE 20080418: 2007-12-19 to 2008-04-18
V1.1.1	July 2008	Vote	V 20080908: 2008-07-10 to 2008-09-08